

LOCATION MAP
NOT TO SCALE

PLANS FOR THE CONSTRUCTION *FOR* PORTSMOUTH HIGH SCHOOL TENNIS COURTS



VICINITY MAP
SCALE: 1"=200'

CITY OF
Portsmouth, NH

PREPARED FOR:
CITY OF PORTSMOUTH
SCHOOL DEPARTMENT
50 Andrew Jarvis Drive
Portsmouth, New Hampshire 03801

CONTENTS

- TITLE SHEET
- GN-01 GENERAL NOTES
- EX-01 EXISTING CONDITIONS PLAN
- BP-01 BORING AND PAVEMENT CORE PLAN
- EC-01 EROSION CONTROL PLAN
- EC-02 EROSION CONTROL NOTES
- DM-01 SITE PREPARATION PLAN
- EL-01 SITE LIGHTING PLAN
- EL-02 SITE LIGHTING SPECS
- EL-03 MUSCO LIGHTING LAYOUT 1
- EL-04 MUSCO LIGHTING LAYOUT 2
- EL-05 MUSCO LIGHTING LAYOUT 3
- SM-01 SITE MATERIALS PLAN
- SL-01 SITE LAYOUT PLAN
- GD-01 GRADING/DRAINAGE PLAN
- DN-01 SITE DETAILS 1
- DN-02 SITE DETAILS 2
- DN-03 SITE DETAILS 3

PREPARED BY:



ARCHITECTURE ENGINEERING ENVIRONMENTAL LAND SURVEYNG

2346 POST ROAD, SUITE 100
WARWICK, RI 02886
(401) 400-4492

LICENSED LANDSCAPE ARCHITECT

PER _____
DOMINICK CELTRUDA, R.L.A.
NH LICENSED LANDSCAPE ARCHITECT NO 00190

DATE _____

DATES

ISSUE DATE: 01/03/2023
REVISION: TBD

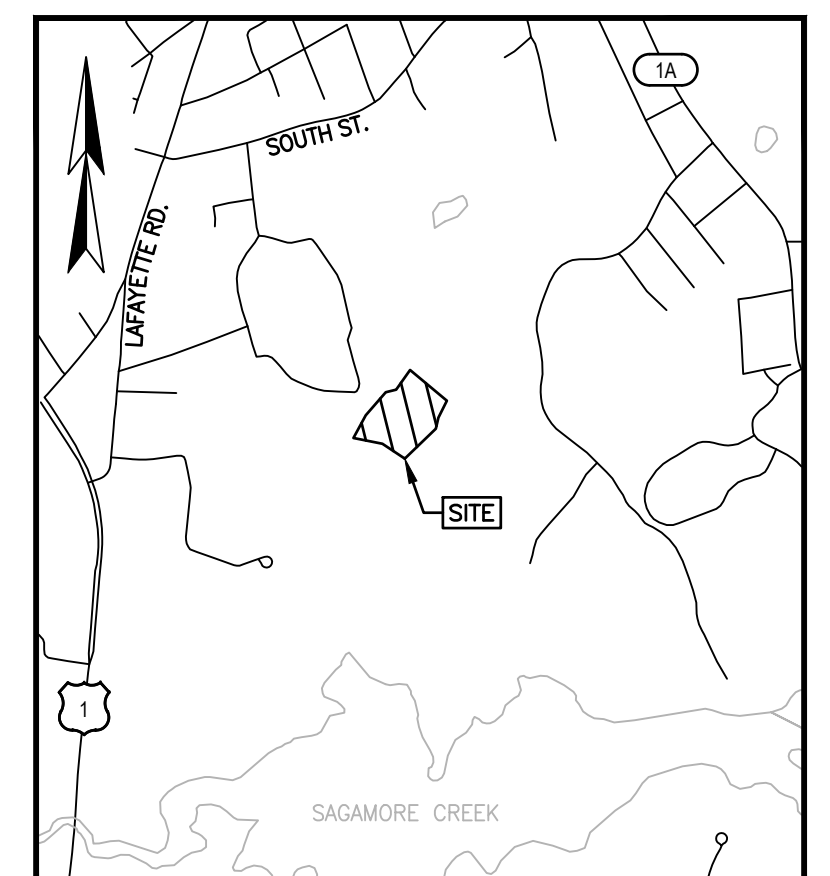
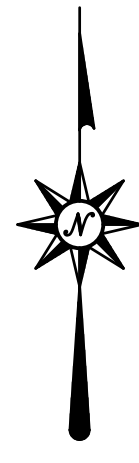

LOCATION MAP (n.t.s.)

NOTES:

1. REFERENCE: PORTSMOUTH HIGH SCHOOL TENNIS COURTS PORTSMOUTH, NH D.S. PROJECT NO. 7155
2. FIELD SURVEY PERFORMED BY L.P.S. & D.D.L. DURING NOVEMBER 2021 USING A TRIMBLE S7 TOTAL STATION AND A TRIMBLE R10 SURVEY GRADE GPS WITH A TRIMBLE TSC3 DATA COLLECTOR AND A TRIMBLE DINI DIGITAL AUTO LEVEL TRAVERSE ADJUSTMENT BASED ON LEAST SQUARE ANALYSIS.
3. HORIZONTAL DATUM BASED ON NAD83(2011) NEW HAMPSHIRE STATE PLANE COORDINATE ZONE (2800) DERIVED FROM REDUNDANT GPS OBSERVATIONS UTILIZING THE KEYNET GPS VRS NETWORK.
4. VERTICAL DATUM IS BASED ON APPROXIMATE NAVD83(GEOD12A) ($\pm 2'$) DERIVED FROM REDUNDANT GPS OBSERVATIONS UTILIZING THE KEYNET GPS VRS NETWORK.
5. JURISDICTIONAL WETLANDS DELINEATED BY JOSEPH W. NOEL DURING MAY/JUNE 2021 IN ACCORDING TO THE:
 - US ARMY CORPS OF ENGINEERS WETLANDS DELINEATION MANUAL, TECHNICAL REPORT 1-87-1 (JANUARY, 1987).
 - REGIONAL SUPPLEMENT TO THE CORPS OF ENGINEERS WETLAND DELINEATION MANUAL: NORTHCENTRAL AND NORTHEAST REGION (2012).
 - NATIONAL LIST OF PLANT SPECIES THAT OCCUR IN WETLANDS: NORTHEAST (REGION 1), U.S. FISH AND WILDLIFE SERVICE (2013).
 - CODE OF ADMINISTRATIVE RULES, WETLANDS BOARD, STATE OF NEW HAMPSHIRE (CURRENT).
 - FIELD INDICATORS OF HYDRIC SOILS IN THE UNITED STATES, VERSION 8.0, 2016 AND (FOR DISTURBED SITES) FIELD INDICATORS FOR IDENTIFYING HYDRIC SOILS IN NEW ENGLAND, VERSION 4, NEHSTC (MAY 2017).
6. PROPER FIELD PROCEDURES WERE FOLLOWED IN ORDER TO GENERATE CONTOURS AT 1' INTERVALS. ANY MODIFICATION OF THIS INTERVAL WILL DIMINISH THE INTEGRITY OF THE DATA, AND DOUCET SURVEY WILL NOT BE RESPONSIBLE FOR ANY SUCH ALTERATION PERFORMED BY THE USER.
7. ALL UNDERGROUND UTILITIES (ELECTRIC, GAS, TEL, WATER, SEWER DRAIN SERVICES) ARE SHOWN IN SCHEMATIC FASHION, THEIR LOCATIONS ARE NOT PRECISE OR NECESSARILY ACCURATE. NO WORK WHATSOEVER SHALL BE UNDERTAKEN USING THIS PLAN TO LOCATE THE ABOVE SERVICES. CONSULT WITH THE PROPER AUTHORITIES CONCERNED WITH THE SUBJECT SERVICE LOCATIONS FOR INFORMATION REGARDING SUCH. CALL DIG-SAFE AT 1-888-DIG-SAFE.

LEGEND

- MAJOR CONTOUR LINE
- MINOR CONTOUR LINE
- APPROXIMATE LOT LINE (PER GIS)
- TREE LINE
- SHRUB LINE
- CHAIN LINK FENCE
- TENNIS NET
- EDGE OF DELINEATED WETLAND
- WETLAND FLAG
- WETLAND AREA
- FLARED END SECTION
- DRAIN LINE
- ROCK/BOULDER
- LEDGE OUTCROP
- SPOT GRADE
- LIGHT POLE (MULTI-ARMS)
- HAND HOLE
- DECIDUOUS TREE
- CONIFEROUS TREE
- EDGE OF PAVEMENT
- SINGLE WHITE LINE
- SINGLE BLACK LINE
- SINGLE BLUE LINE
- SINGLE YELLOW LINE

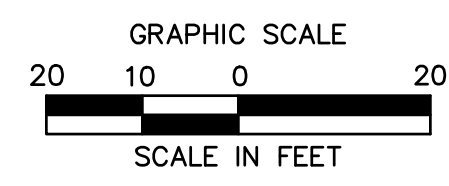

Jan 11, 2023 2:04pm jwheeler c:\wbs21\18\2101920\DWG\EX-01.dwg

©2023 BL COMPANIES, INC. THESE DRAWINGS SHALL NOT BE UTILIZED BY ANY PERSON, FIRM OR CORPORATION WITHOUT THE SPECIFIC WRITTEN PERMISSION OF BL COMPANIES.



355 Research Parkway
Merriden, CT 06450
(203) 630-1406
(203) 630-2615 Fax

TENNIS COURT RENOVATION
PORTSMOUTH HIGH SCHOOL
50 ANDREW JARVIS DR., PORTSMOUTH, NH 03801

| REVISIONS | |
|-----------|------|
| No. | Date |
| | |
| | |

Surveyed
 Drawn JW
 Reviewed DC
 Scale 1"=20'-0"
 Project No. 2101920
 Date 01/03/2023

CAD File: _____

Title

EXISTING CONDITIONS PLAN

Sheet No.

EX-01

Verif. G3: E:\B2100875 - 23270192001

| BORING INFORMATION | | BORING | |
|--------------------|-------|------------|-------|
| DATE | NO. | DATE | NO. |
| 2023.01.11 | PC-1 | 2023.01.11 | PC-2 |
| 2023.01.11 | PC-3 | 2023.01.11 | PC-4 |
| 2023.01.11 | PC-5 | 2023.01.11 | PC-6 |
| 2023.01.11 | PC-7 | 2023.01.11 | PC-8 |
| 2023.01.11 | PC-9 | 2023.01.11 | PC-10 |
| 2023.01.11 | B-101 | 2023.01.11 | B-102 |

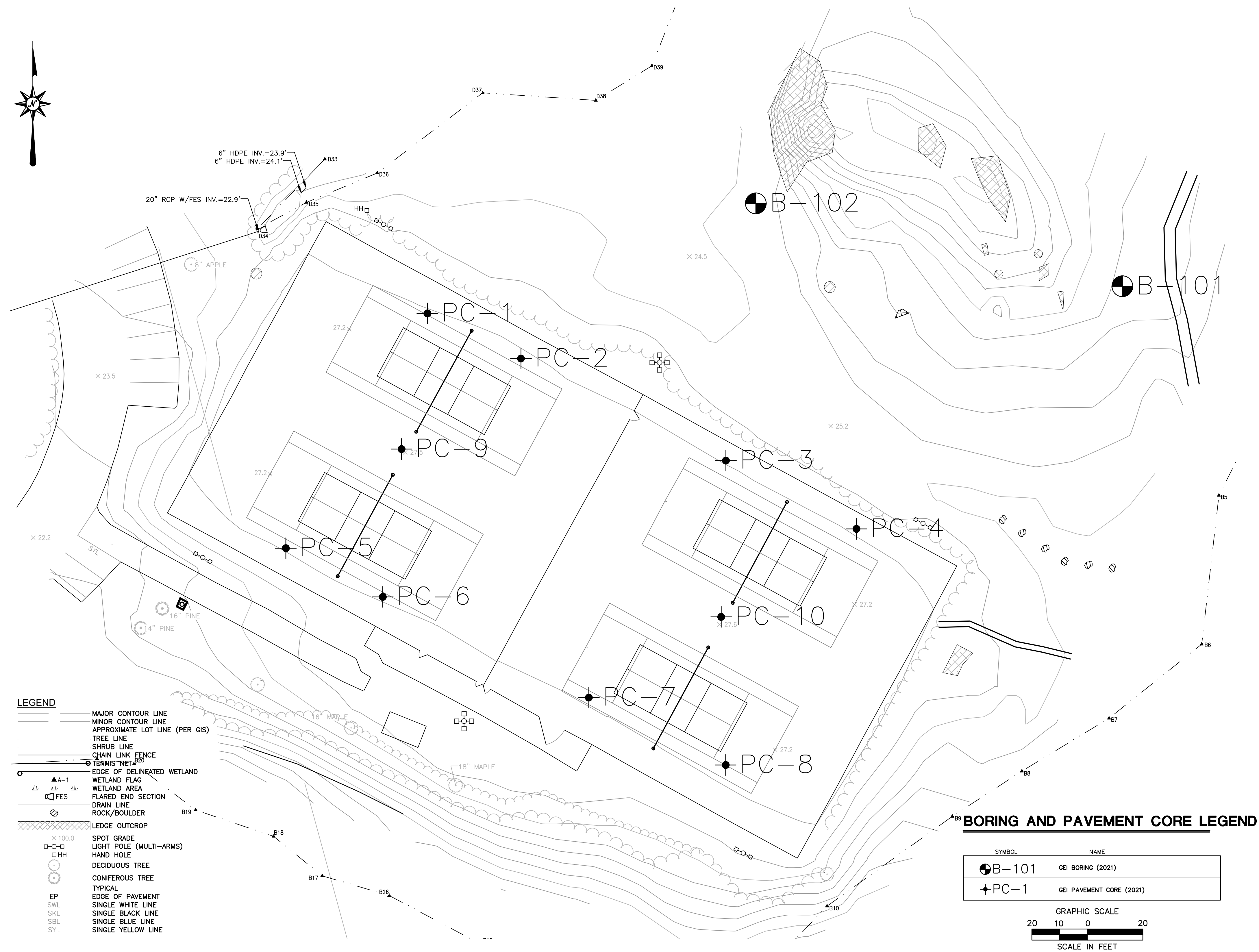

LEGEND

| | |
|----------|--------------------------------|
| [Symbol] | MAJOR CONTOUR LINE |
| [Symbol] | MINOR CONTOUR LINE |
| [Symbol] | APPROXIMATE LOT LINE (PER GIS) |
| [Symbol] | TREE LINE |
| [Symbol] | SHRUB LINE |
| [Symbol] | CHAIN LINK FENCE |
| [Symbol] | TENNIS NET |
| [Symbol] | EDGE OF DELINEATED WETLAND |
| [Symbol] | WETLAND FLAG |
| [Symbol] | WETLAND AREA |
| [Symbol] | FLARED END SECTION |
| [Symbol] | DRAIN LINE |
| [Symbol] | ROCK/BOULDER |
| [Symbol] | LEDGE OUTCROP |
| [Symbol] | SPOT GRADE |
| [Symbol] | LIGHT POLE (MULTI-ARMS) |
| [Symbol] | HAND HOLE |
| [Symbol] | DECIDUOUS TREE |
| [Symbol] | CONIFEROUS TREE |
| [Symbol] | TYPICAL |
| [Symbol] | EDGE OF PAVEMENT |
| [Symbol] | SINGLE WHITE LINE |
| [Symbol] | SINGLE BLACK LINE |
| [Symbol] | SINGLE BLUE LINE |
| [Symbol] | SINGLE YELLOW LINE |

BORING AND PAVEMENT CORE LEGEND

| SYMBOL | NAME |
|-------------------------|-------------------------------|
| [Circle with crosshair] | B-101 GEI BORING (2021) |
| [Square with crosshair] | PC-1 GEI PAVEMENT CORE (2021) |

GRAPHIC SCALE
20 10 0 20
SCALE IN FEET

| BORING INFORMATION | | BORING | |
|--------------------|-------|------------|-------|
| DATE | NO. | DATE | NO. |
| 2023.01.11 | PC-8 | 2023.01.11 | PC-9 |
| 2023.01.11 | PC-10 | 2023.01.11 | B-101 |
| 2023.01.11 | B-102 | 2023.01.11 | B-102 |

Jan 11, 2023, 2:04pm J:\wheeler_c\2101920\DWG\BP210192001.dwg
Lisp: BL-C1



EROSION & SED. CONTROL LEGEND

| SYMBOL | NAME |
|--------|--|
| | LIMIT OF DISTURBANCE/CONTRACT LIMIT LINE |
| | SILT FENCE |
| | PROPOSED TREELINE |
| | 5' WIDE CRUSHED STONE PERIMETER |
| | CONCRETE PAD |
| | BITUMINOUS PAVEMENT |

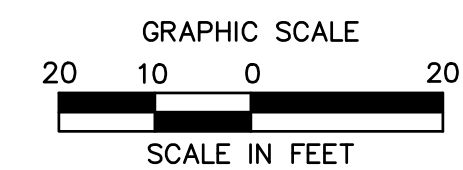
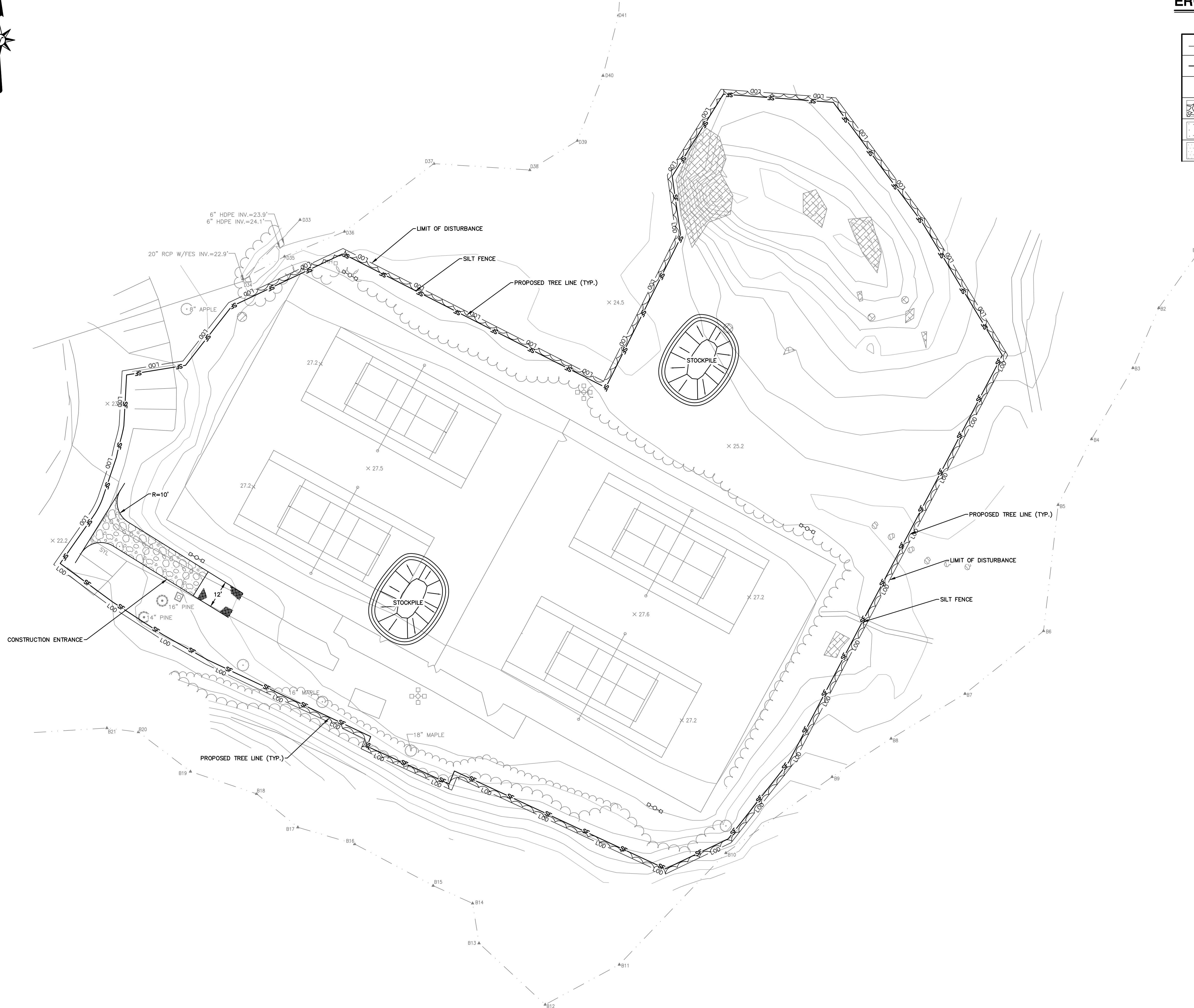

ARCHITECTURE
ENGINEERING
ENVIRONMENTAL
LAND SURVEYING

355 Research Parkway
Meriden, CT 06450
(203) 630-1406
(203) 630-2615 Fax

TENNIS COURT RENOVATION
PORTSMOUTH HIGH SCHOOL
50 ANDREW JARVIS DR., PORTSMOUTH, NH 03801

Desc.

REVISIONS
No. Date

Surveyed
Drawn R.B.
Reviewed M.M.
Scale 1"=20'-0"
Project No. 2101920
Date 01/03/2023

CAD File:

Title

**SEDIMENTATION
AND EROSION
CONTROL PLAN**

Sheet No.

EC-01

EROSION & SEDIMENT CONTROL NOTES:

- ALL SEDIMENT AND EROSION CONTROL DEVICES SHALL BE PUT INTO PLACE PRIOR TO BEGINNING ANY CONSTRUCTION OR DEMOLITION. REFER TO PLANS FOR APPROXIMATE LOCATION OF EROSION AND SEDIMENT CONTROL. REFER TO SPECIFICATION AND DETAILS FOR TYPE OF EROSION AND SEDIMENT CONTROL.
- THE CONTRACTOR SHALL BE RESPONSIBLE FOR CONTINUAL MAINTENANCE OF ALL CONTROL DEVICES THROUGHOUT THE DURATION OF THE PROJECT.
- CONTRACTOR SHALL MEET ALL THE STATE OF NEW HAMPSHIRE AND THE CITY OF PORTSMOUTH WETLAND ORDINANCE REGULATIONS FOR SEDIMENT AND EROSION CONTROL.
- EXCAVATED MATERIAL STOCKPILED ON THE SITE SHALL BE SURROUNDED BY A RING OF UNBROKEN SEDIMENT AND EROSION CONTROL FENCE. THE LIMITS OF ALL GRADING AND DISTURBANCE SHALL BE KEPT TO A MINIMUM WITHIN THE APPROVED AREA OF CONSTRUCTION. ALL AREAS OUTSIDE OF THE LIMIT OF CONTRACT SHALL REMAIN TOTALLY UNDISTURBED UNLESS OTHERWISE APPROVED BY OWNER'S REPRESENTATIVE.
- ALL CATCH BASINS AND DRAIN GRATES WITHIN THE LIMIT OF WORK SHALL BE PROTECTED WITH SILT SACKS DURING THE ENTIRE DURATION OF CONSTRUCTION.
- EROSION CONTROL BARRIERS TO BE INSTALLED AT THE TOE OF SLOPES. SEE GRADING AND DRAINAGE PLANS, NOTES, DETAILS, AND SPECIFICATIONS.
- THE CONTRACTOR SHALL PROVIDE DUST CONTROL FOR CONSTRUCTION OPERATIONS AS APPROVED BY THE OWNER'S REPRESENTATIVE AND NEW HAMPSHIRE DEPARTMENT OF ENVIRONMENTAL SCIENCES REQUIREMENTS.
- ALL POINTS OF CONSTRUCTION EGRESS OR INGRESS SHALL BE MAINTAINED TO PREVENT TRACKING OR FLOWING OF SEDIMENT ON TO PUBLIC/ PRIVATE ROADS.
- ALL MATERIAL HAULING VEHICLES SHALL BE COMPLETELY COVERED PRIOR TO LEAVING THE SITE.
- CONTRACTOR SHALL BE RESPONSIBLE FOR WHEEL CLEANING OF ALL CONSTRUCTION VEHICLES PRIOR TO EXITING THE SITE. CONTRACTOR SHALL ENSURE THAT MATERIAL HAULING VEHICLES REMAIN ON PAVED SURFACES AS MUCH AS POSSIBLE.
- ALL EROSION AND SEDIMENT CONTROL MEASURES ARE TO BE CONSTRUCTED AND MAINTAINED IN ACCORDANCE WITH THE NEW HAMPSHIRE DEPARTMENT OF ENVIRONMENTAL SCIENCES AND THE NPDES GENERAL PERMIT FOR STORMWATER DISCHARGES FROM CONSTRUCTION ACTIVITIES.
- ANY EROSION AND SEDIMENT CONTROL MEASURES FOR THE STABILIZATION OF SLOPES ARE TEMPORARY FOR CONSTRUCTION PHASES ONLY. SEE GRADING PLAN FOR FINAL STABILIZATION OF SLOPES.
- SEDIMENT CONTROL MEASURES SHALL BE ADJUSTED TO MEET FIELD CONDITIONS AT THE TIME OF AND DURING ALL PHASES OF CONSTRUCTION AND BE CONSTRUCTED PRIOR TO AND IMMEDIATELY AFTER ANY GRADING OR DISTURBANCE OF EXISTING SURFACE MATERIAL ON THE SITE.
- DAILY INSPECTION AND MAINTENANCE OF ALL SEDIMENT CONTROL STRUCTURES SHALL BE PROVIDED TO ENSURE THAT THE INTENDED PURPOSES IS ACCOMPLISHED. THE CONTRACTOR SHALL BE RESPONSIBLE FOR ALL SEDIMENT LEAVING THE LIMIT OF WORK. SEDIMENT CONTROL MEASURES SHALL BE IN WORKING CONDITION AT THE END OF EACH WORKING DAY.
- ALL SEDIMENT WILL BE PREVENTED FROM ENTERING ANY STORM DRAINAGE SYSTEM.
- ALL DRAINAGE SWALES AND GROUND SURFACES WITHIN THE LIMIT OF WORK SHALL BE PROTECTED.
- AFTER SIGNIFICANT RAINFALL SEDIMENT CONTROL STRUCTURES SHALL BE INSPECTED FOR INTEGRITY. ANY DAMAGED DEVICES SHALL BE CORRECTED IMMEDIATELY.
- ALL STOCKPILES SHALL BE PROTECTED. STOCKPILES SHALL BE PROTECTED FROM CONTACT WITH ONSITE STORMWATER RUNOFF USING TEMPORARY PERIMETER SEDIMENT BARRIERS. A COVER (TARP) OR APPROPRIATE TEMPORARY STABILIZATION WILL BE PROVIDED TO MINIMIZE SEDIMENT DISCHARGE.
- STABILIZED PORTIONS OF A SITE SHALL BE INSPECTED AT LEAST ONCE PER MONTH.
- ANY SEDIMENT TRACKED ONTO PAVED AREAS SHALL BE SWEEPED AT THE END OF EACH WORKING DAY.
- ALL TOPSOIL ENCOUNTERED WITHIN THE WORK AREA SHALL BE STRIPPED TO ITS FULL DEPTH AND STOCKPILED FOR REUSE. TOPSOIL NOT NEEDED AFTER COMPLETION OF ALL FINAL TOPSOIL SPREADING AND GRASSING SHALL BE REMOVED FROM THE SITE AND LEGALLY RECYCLED OR DISPOSED OF. TOPSOIL PILES SHALL REMAIN SEGREGATED FROM EXCAVATED SUBSURFACE SOIL MATERIALS.
- TEMPORARY DIVERSION DITCHES, PERMANENT DITCHES, CHANNELS, EMBANKMENTS AND ANY DENUDED SURFACE WHICH WILL BE EXPOSED FOR A PERIOD OF 14 CALENDAR DAYS OR MORE SHALL BE CONSIDERED CRITICAL VEGETATION AREAS. THESE AREAS SHALL BE MULCHED WITH STRAW. MULCH SHALL BE SPREAD UNIFORMLY IN A CONTINUOUS BLANKET OF SUFFICIENT THICKNESS TO COMPLETELY HIDE THE SOIL FROM VIEW.
- AN EROSION CONTROL BARRIER SHALL BE INSTALLED ALONG THE EDGE OF PROJECT PRIOR TO COMMENCEMENT OF DEMOLITION OR CONSTRUCTION ACTIVITIES.
- THE CONTRACTOR IS RESPONSIBLE FOR REMOVAL OF ALL EROSION AND SEDIMENT CONTROLS AT THE COMPLETION OF SITE CONSTRUCTION.
- MEANS OF EROSION AND SEDIMENT PROTECTION AS NOTED ON THE DRAWINGS INDICATE THE MINIMUM PROVISIONS NECESSARY. ADDITIONAL MEANS OF PROTECTION SHALL BE PROVIDED BY THE CONTRACTOR AS REQUIRED FOR CONTINUED OR UNFORSEEN EROSION PROBLEMS, AT NO ADDITIONAL EXPENSE TO THE OWNER.
- THE CONTRACTOR SHALL USE TEMPORARY SEEDING, MULCHING OR OTHER APPROVED STABILIZATION MEASURES TO PROTECT EXPOSED AREAS DURING PROLONGED CONSTRUCTION OR OTHER LAND DISTURBANCES.
- A STORMWATER POLLUTION PREVENTION PLAN (SWPPP) SHALL BE PREPARED PRIOR TO THE BEGINNING OF CONSTRUCTION CONSISTENT WITH THE REQUIREMENTS OF THE NATIONAL POLLUTANT DISCHARGE ELIMINATION SYSTEM (NPDES) CONSTRUCTION GENERAL PERMIT. THE CONTRACTOR WILL BE RESPONSIBLE FOR COMPLIANCE WITH CONDITIONS OF THE SWPPP THROUGHOUT CONSTRUCTION.

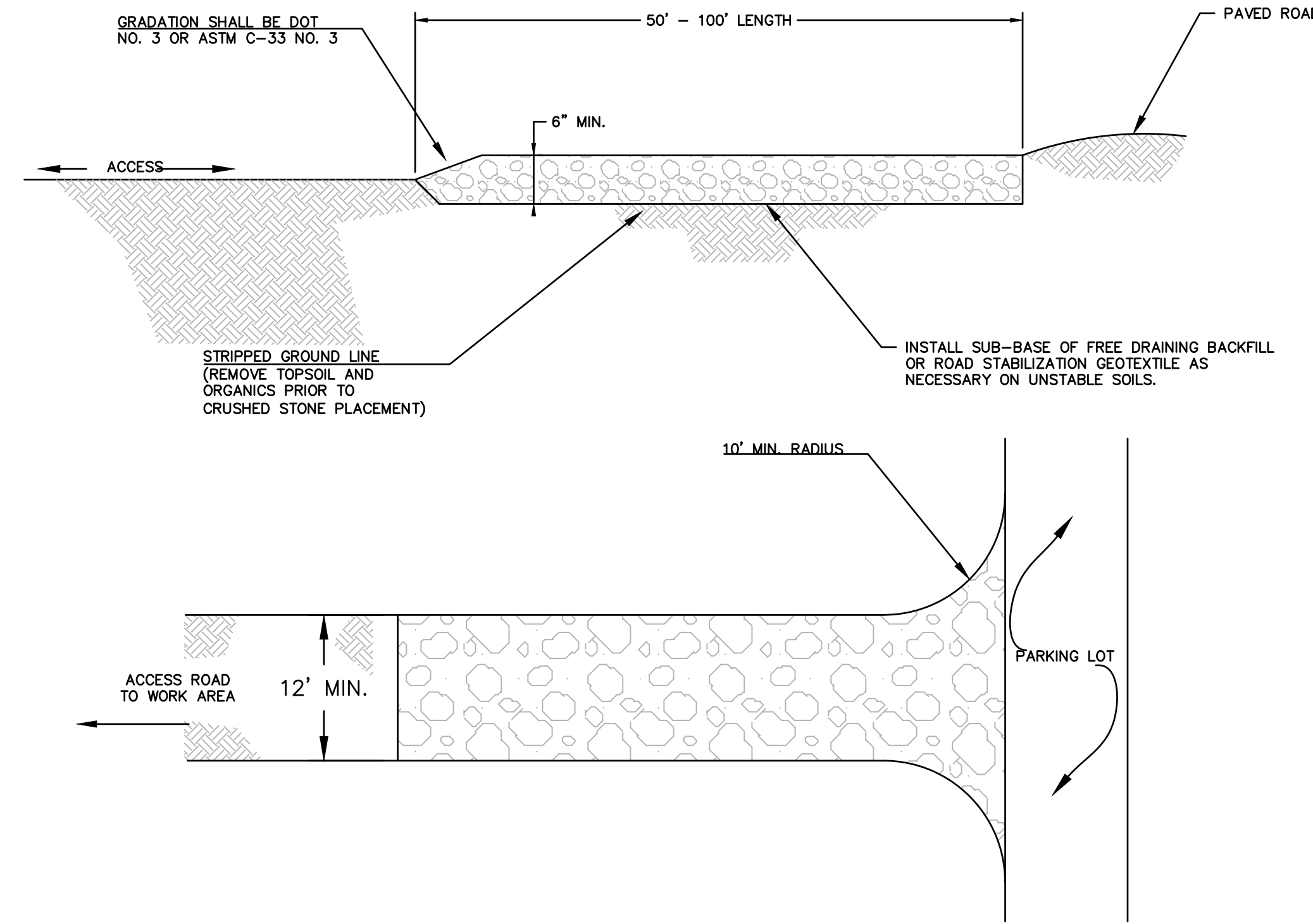

CONSTRUCTION ENTRANCE

N.T.S.

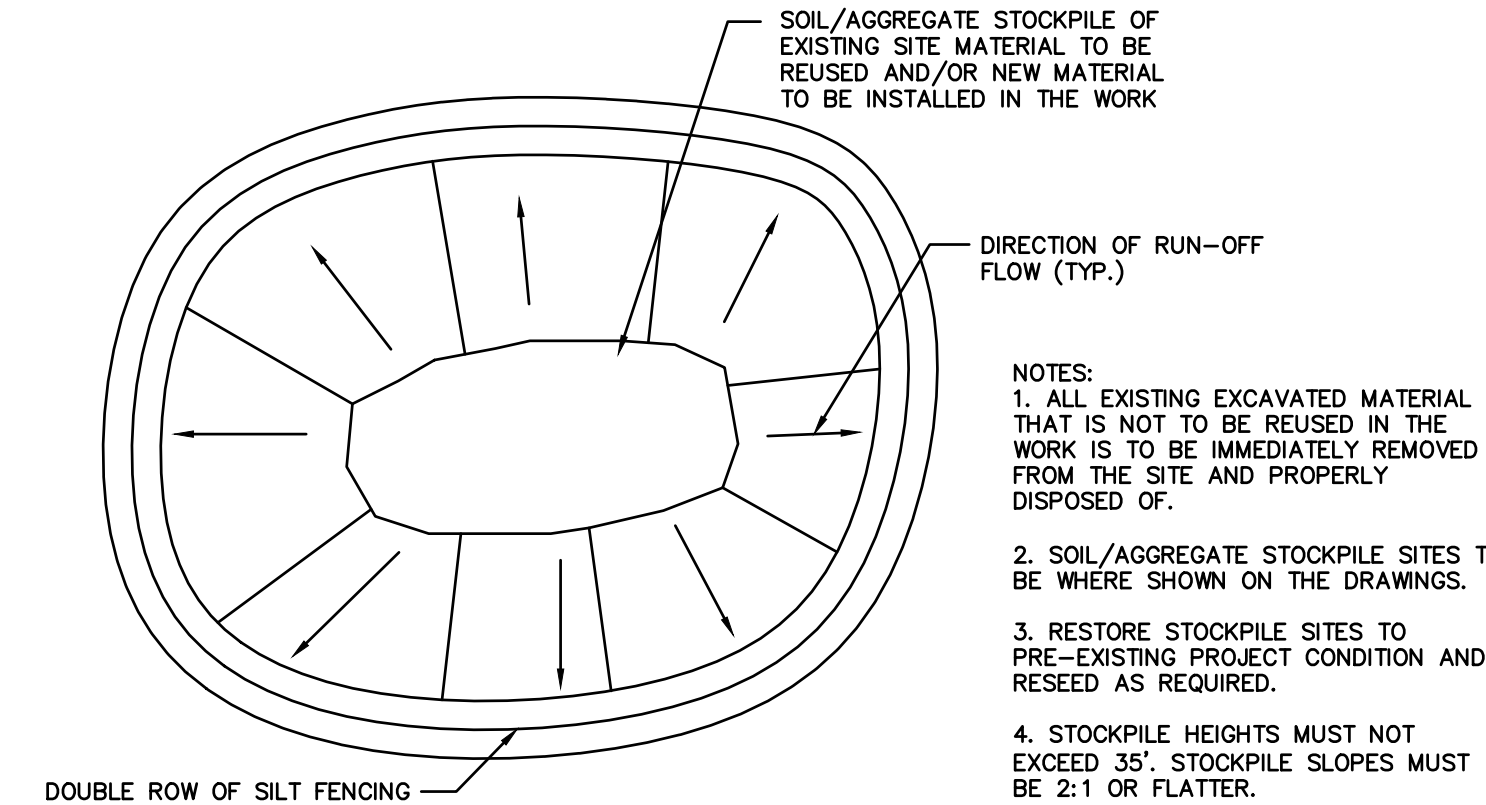

MATERIALS STOCKPILE DETAIL

N.T.S.

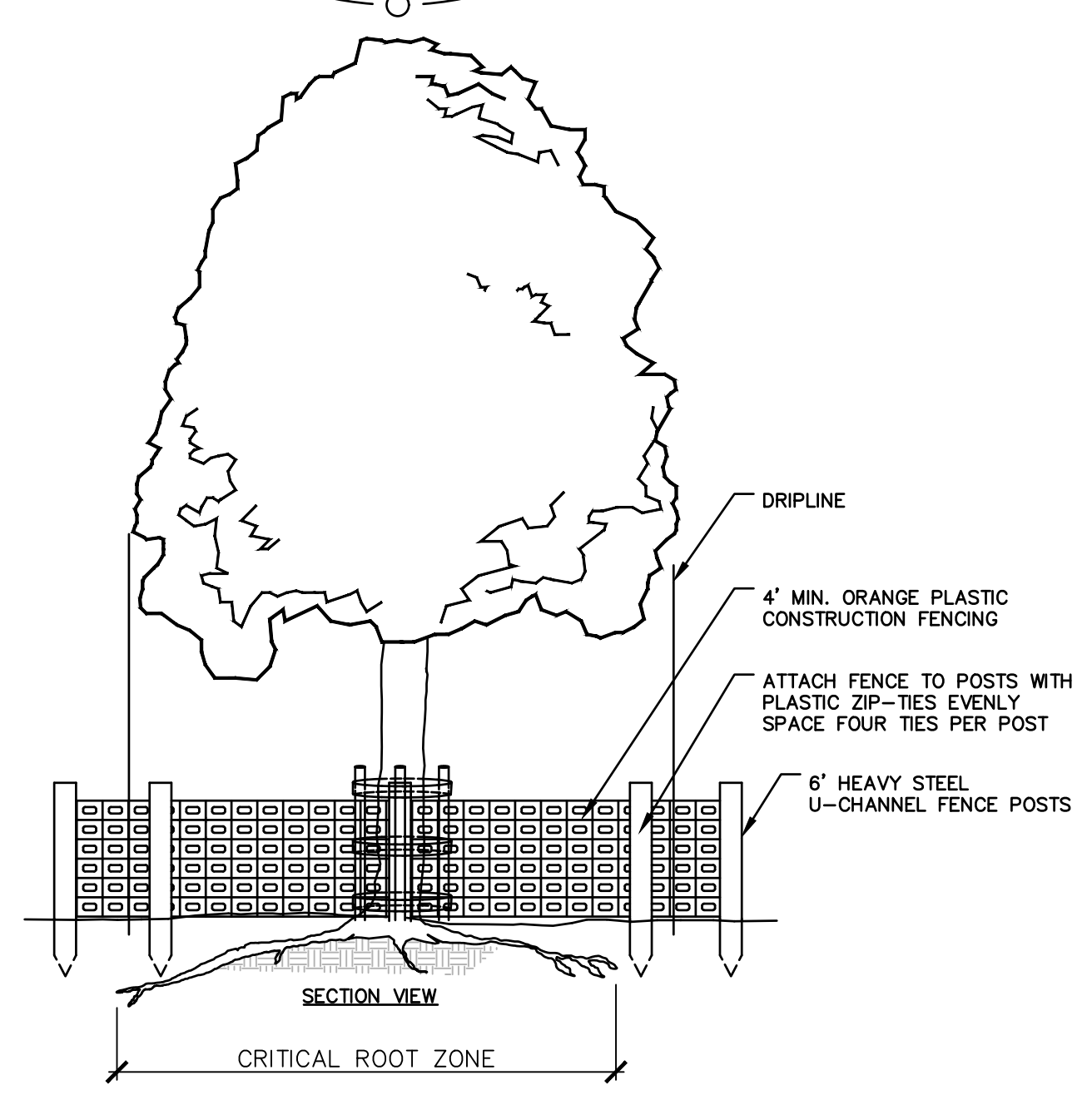
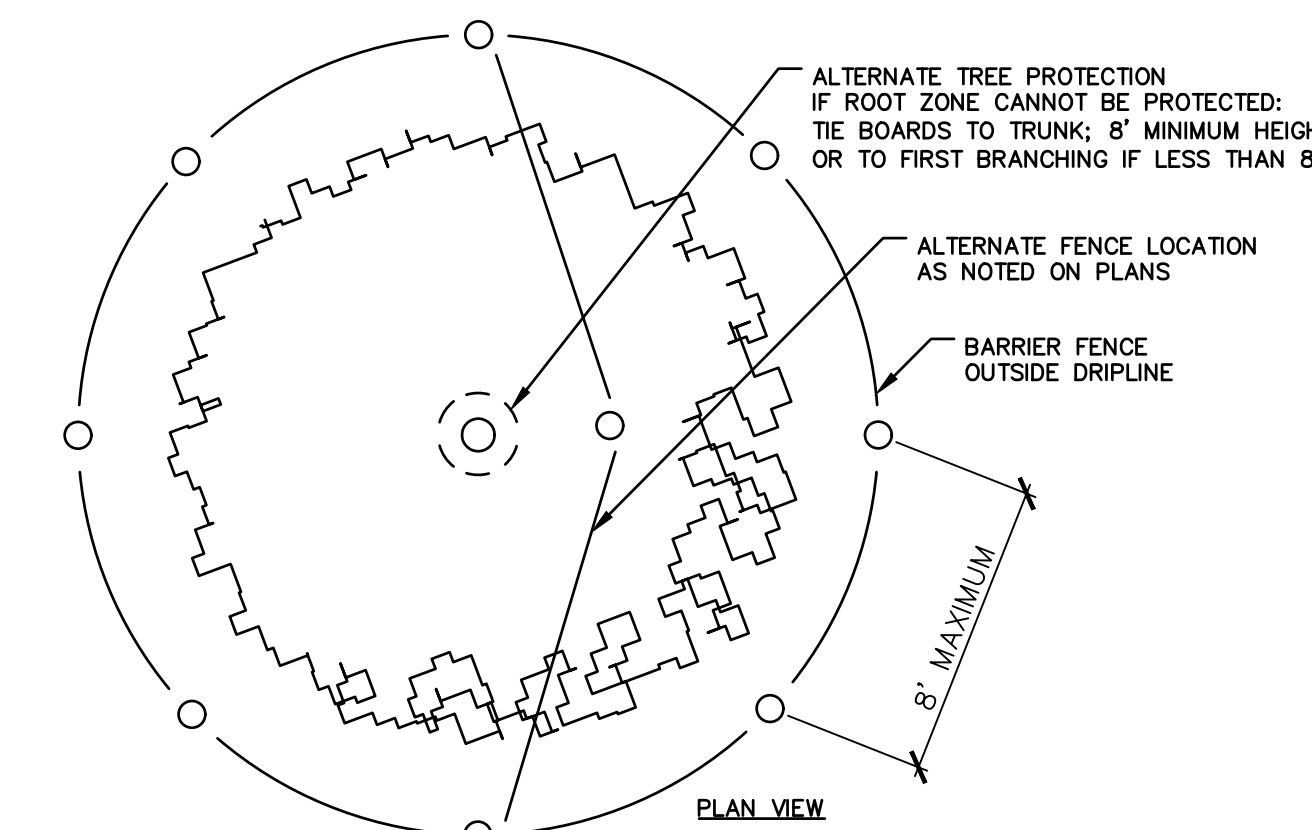

TREE PROTECTION

N.T.S.

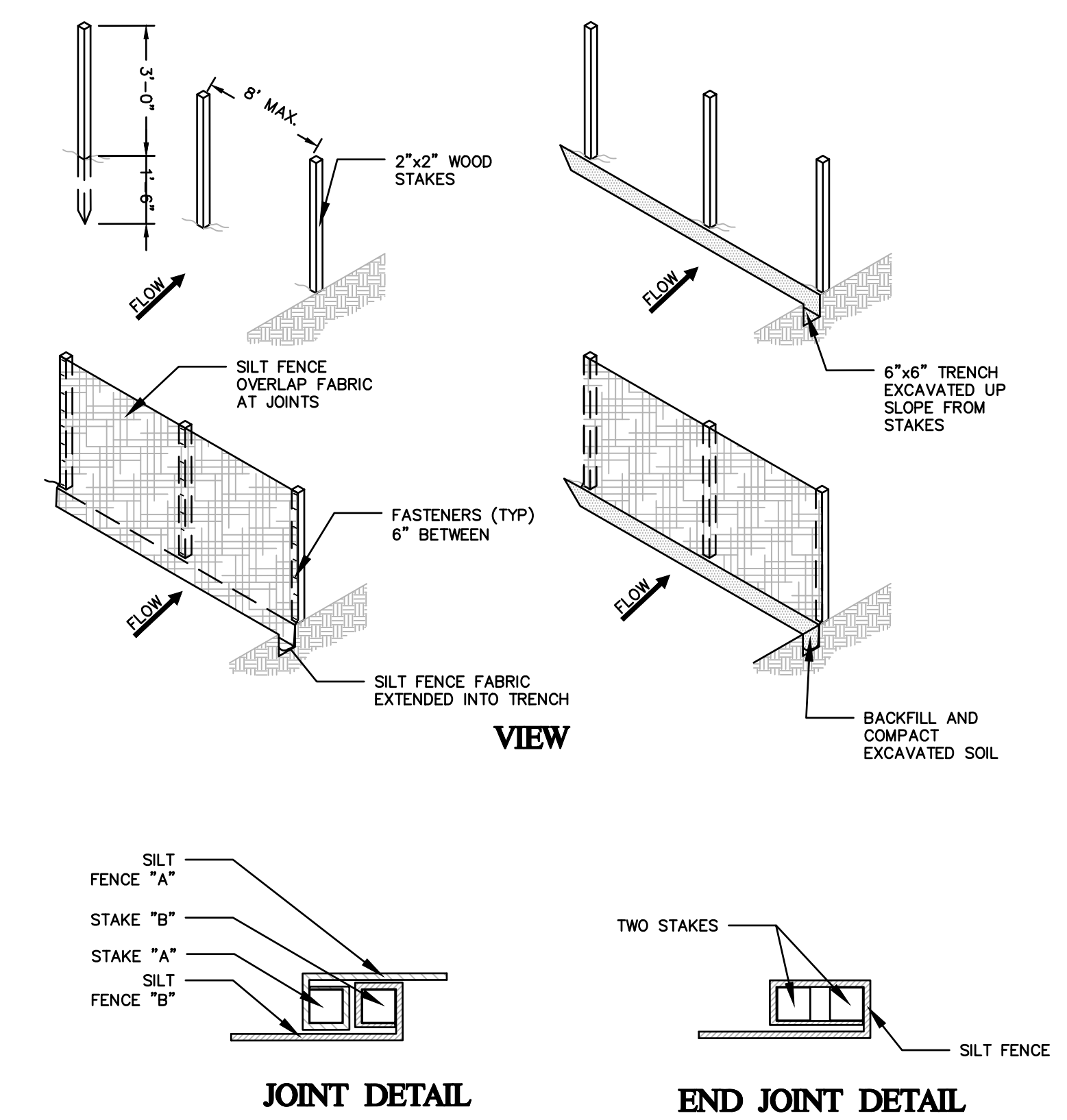

SILT FENCE

N.T.S.

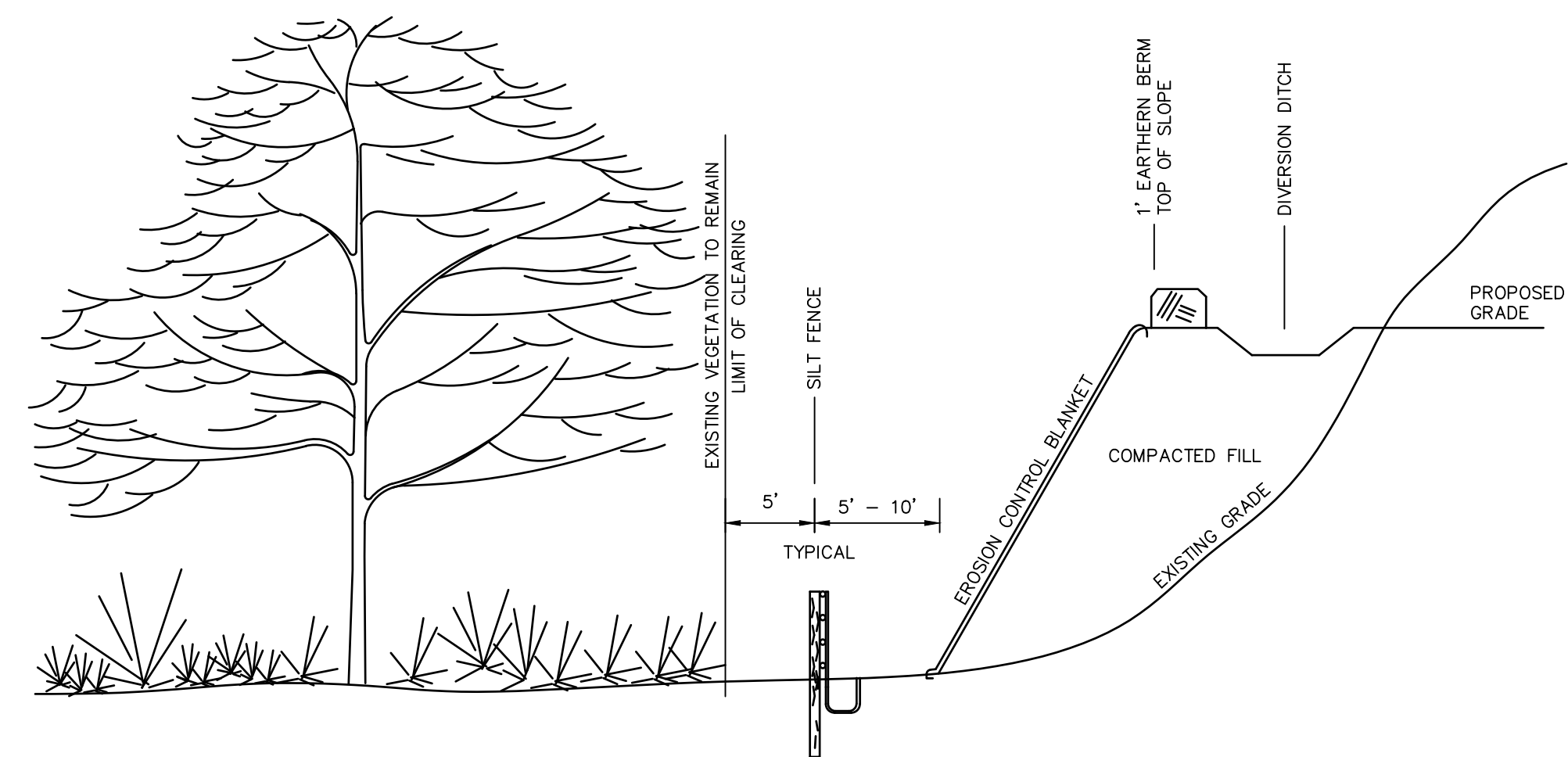

TYPICAL EROSION CONTROL ON SLOPES

N.T.S.

BLEC-011



355 Research Parkway
Merriden, CT 06450
(203) 630-1406
(203) 630-2615 Fax

TENNIS COURT RENOVATION
PORTSMOUTH HIGH SCHOOL
50 ANDREW JARVIS DR., PORTSMOUTH, NH 03801

| REVISIONS | Desc. |
|-----------|-------|
| No. | Date |
| | |
| | |

Surveyed
Drawn JW
Reviewed JW
Scale
Project No. 2101920
Date 01/03/2023

CAD File:
Title: **SEDIMENTATION & EROSION CONTROL NOTES & DETAILS**
Sheet No.

EC-02



SITE PREPARATION LEGEND

| SYMBOL | NAME |
|--------------------|--|
| — LOD — | LIMIT OF DISTURBANCE/CONTRACT LIMIT LINE |
| — SF — | SILT FENCE |
| XXXXXXXXXXXXXXXXXX | REMOVE AND DISPOSE EXISTING FENCE |
| ▨ | REMOVE AND DISPOSE EXISTING LANDSCAPE |
| X | REMOVE AND DISPOSE OF EXISTING STRUCTURE/FURNISHING/LANDSCAPE ITEM |
| (S) | PROTECT EXISTING TREE TO REMAIN (SYMBOL NOT TO SCALE) |
| ~ | PROPOSED TREELINE |

REMOVAL AND DISPOSAL OF STRUCTURES AND FURNISHINGS SHALL INCLUDE FOUNDATION UNLESS OTHERWISE NOTED

GRUBBING NOTE
GRUBBING ACTIVITIES TO OCCUR IN STAGES AND ONLY WHERE EXCAVATION AND SUBSEQUENT STABILIZATION MEASURES ARE TO IMMEDIATELY FOLLOW.

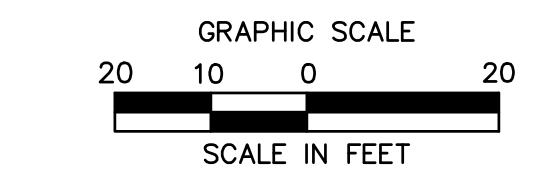
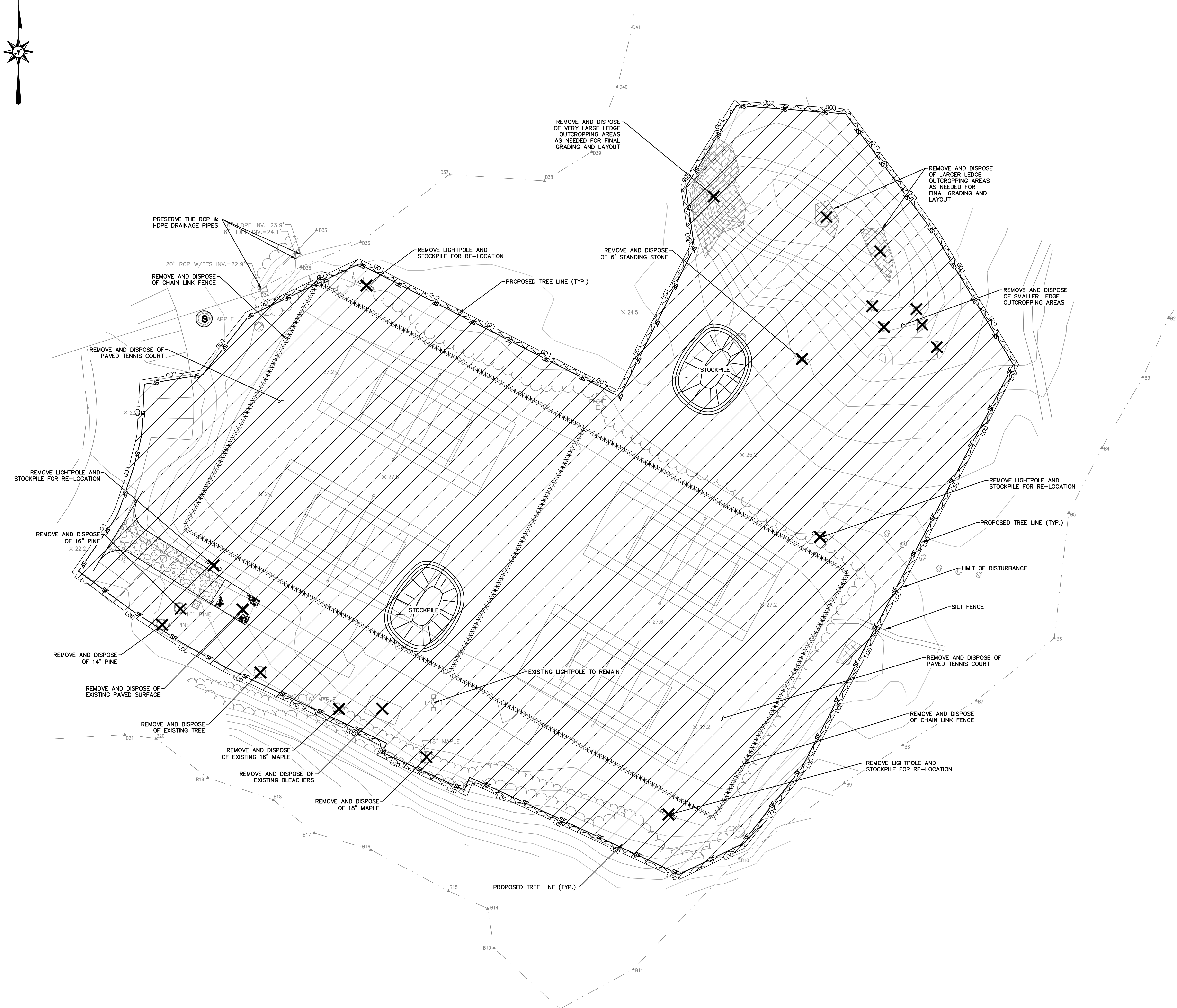

355 Research Parkway
Merriden, CT 06450
(203) 630-1406
(203) 630-2615 Fax

TENNIS COURT RENOVATION
PORTSMOUTH HIGH SCHOOL
50 ANDREW JARVIS DR., PORTSMOUTH, NH 03801

| REVISIONS | Desc. |
|-----------|-------|
| No. | Date |

Surveyed _____
 Drawn JW
 Reviewed DC
 Scale 1"=20'-0"
 Project No. 2101920
 Date 01/03/2023

CAD File: _____
 Title
SITE PREPARATION PLAN
 Sheet No.

DM-01

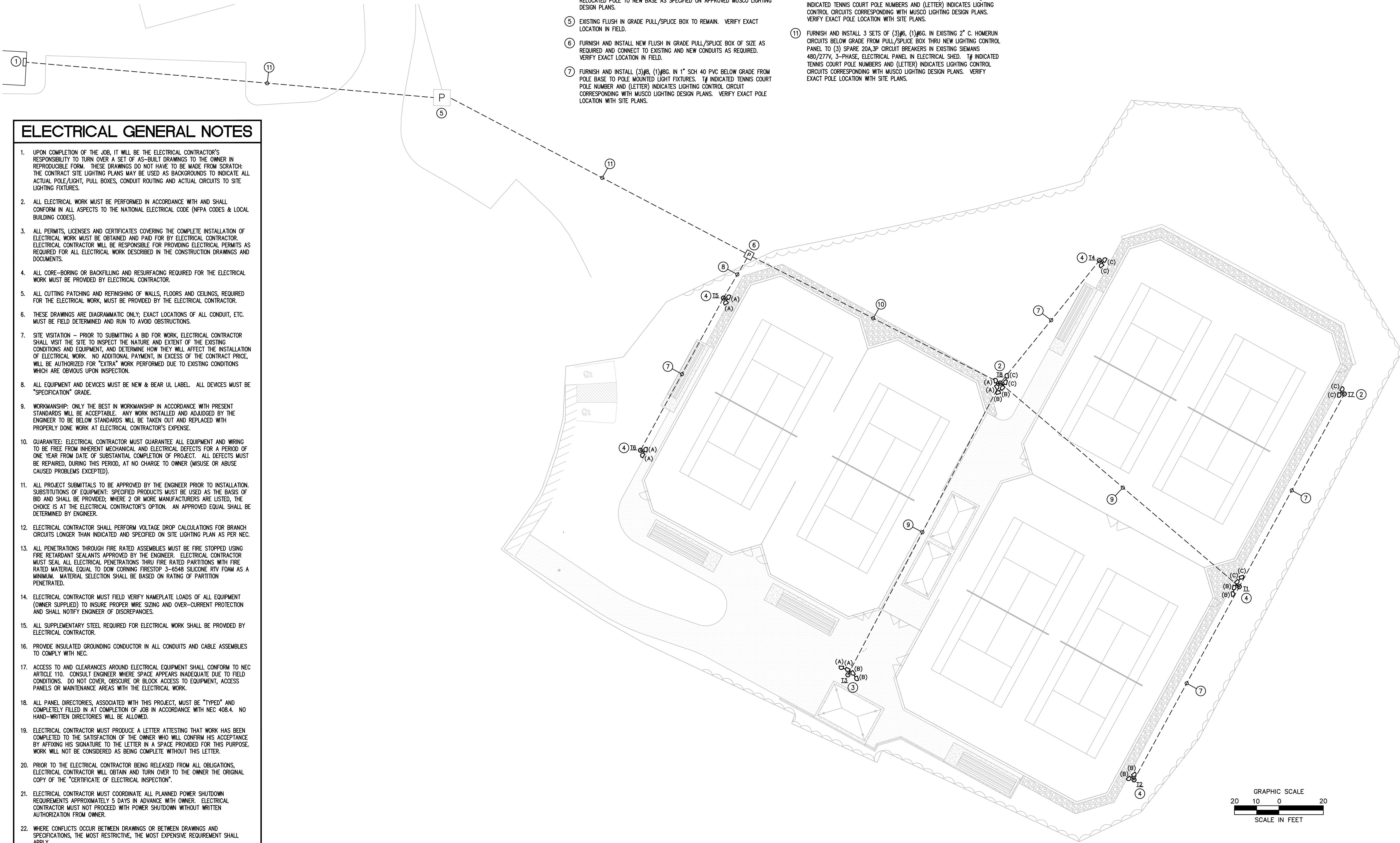

DRAWING KEY NOTES:

- ① FURNISH AND INSTALL NEW LIGHTING CONTROL PANEL AND 120V LIGHTING CONTROL CIRCUIT TO NEW 20A/1P CIRCUIT BREAKER IN EXISTING 208/120V ELECTRICAL PANEL IN ELECTRICAL SHED WITH (2)#12, (1)#2G IN 3/4" CONDUIT AS INDICATED ON APPROVED MUSCO LIGHTING DESIGN PLANS. VERIFY EXACT LOCATION OF SHED AND MOUNTING LOCATION OF LIGHTING CONTROL PANEL IN FIELD.
- ② FURNISH AND INSTALL NEW BASE, POLE, POLE-TOP MOUNT AND LIGHT FIXTURES AS SPECIFIED ON APPROVED MUSCO LIGHTING DESIGN PLANS.
- ③ FURNISH AND INSTALL NEW POLE-TOP MOUNT AND LIGHT FIXTURES ON EXISTING POLE/BASE TO REMAIN AS SPECIFIED ON APPROVED MUSCO LIGHTING DESIGN PLANS.
- ④ FURNISH AND INSTALL NEW BASE, POLE-TOP MOUNT, LIGHT FIXTURES AND RELOCATED POLE TO NEW BASE AS SPECIFIED ON APPROVED MUSCO LIGHTING DESIGN PLANS.
- ⑤ EXISTING FLUSH IN GRADE PULL/SPLICE BOX TO REMAIN. VERIFY EXACT LOCATION IN FIELD.
- ⑥ FURNISH AND INSTALL NEW FLUSH IN GRADE PULL/SPLICE BOX OF SIZE AS REQUIRED AND CONNECT TO EXISTING AND NEW CONDUITS AS REQUIRED. VERIFY EXACT LOCATION IN FIELD.
- ⑦ FURNISH AND INSTALL (3)#8, (1)#6G. IN 1" SCH 40 PVC BELOW GRADE FROM POLE BASE TO POLE MOUNTED LIGHT FIXTURES. T# INDICATED TENNIS COURT POLE NUMBER AND (LETTER) INDICATES LIGHTING CONTROL CIRCUIT CORRESPONDING WITH MUSCO LIGHTING DESIGN PLANS. VERIFY EXACT POLE LOCATION WITH SITE PLANS.
- ⑧ FURNISH AND INSTALL (3)#8, (1)#6G. IN 1" SCH 40 PVC BELOW GRADE FROM PULL/SPLICE BOX TO POLE MOUNTED LIGHT FIXTURES. SPLICE INTO CIRCUIT "A" HOMERUN CIRCUIT WRING IN PULL/SPLICE BOX. T# INDICATED TENNIS COURT POLE NUMBER AND (LETTER) INDICATES LIGHTING CONTROL CIRCUIT CORRESPONDING WITH MUSCO LIGHTING DESIGN PLANS. VERIFY EXACT POLE LOCATION WITH SITE PLANS.
- ⑨ FURNISH AND INSTALL 2 SET OF (3)#8, (1)#6G. IN 1-1/4" SCH 40 PVC BELOW GRADE FROM POLE BASE TO POLE MOUNTED LIGHT FIXTURES. T# INDICATED TENNIS COURT POLE NUMBER AND (LETTER) INDICATES LIGHTING CONTROL CIRCUITS CORRESPONDING WITH MUSCO LIGHTING DESIGN PLANS. VERIFY EXACT POLE LOCATION WITH SITE PLANS.
- ⑩ FURNISH AND INSTALL 3 SETS OF (3)#8, (1)#6G. IN 2" SCH 40 PVC HOMERUN CIRCUITS BELOW GRADE FROM POLE BASE THRU PULL/SPLICE BOX. T# INDICATED TENNIS COURT POLE NUMBERS AND (LETTER) INDICATES LIGHTING CONTROL CIRCUITS CORRESPONDING WITH MUSCO LIGHTING DESIGN PLANS. VERIFY EXACT POLE LOCATION WITH SITE PLANS.
- ⑪ FURNISH AND INSTALL 3 SETS OF (3)#8, (1)#6G. IN EXISTING 2" C. HOMERUN CIRCUITS BELOW GRADE FROM PULL/SPLICE BOX THRU NEW LIGHTING CONTROL PANEL TO (3) SPARE 20A,3P CIRCUIT BREAKERS IN EXISTING SIEMENS 480/277V, 3-PHASE, ELECTRICAL PANEL IN ELECTRICAL SHED. T# INDICATED TENNIS COURT POLE NUMBERS AND (LETTER) INDICATES LIGHTING CONTROL CIRCUITS CORRESPONDING WITH MUSCO LIGHTING DESIGN PLANS. VERIFY EXACT POLE LOCATION WITH SITE PLANS.

GENERAL SITE LIGHTING NOTES:

- 1. UPON COMPLETION OF THE JOB, IT WILL BE THE ELECTRICAL CONTRACTOR'S RESPONSIBILITY TO TURN OVER A SET OF AS-BUILT DRAWINGS TO THE OWNER IN REPRODUCIBLE FORM. THESE DRAWINGS DO NOT HAVE TO BE MADE FROM SCRATCH: THE CONTRACT SITE LIGHTING PLAN MAY BE USED AS BACKGROUNDS WITH THE ACTUAL CIRCUIT CHANGES ADDED.
- 2. THE ELECTRICAL LIGHTING DRAWINGS SHOW LIGHTING AND DEVICE LOCATIONS ONLY. WIRING SHOWN IS SCHEMATIC IN NATURE, INTENDED TO SHOW CIRCUITING AND CONTROL WIRING. REFER TO APPROVED MUSCO LIGHTING DESIGN PLANS FOR LIGHT FIXTURE, POLES, POLE-TOP MOUNTS, BASE AND CONTROL PANEL SPECIFICATIONS, REQUIREMENTS, WIRING DIAGRAMS AND DETAILS.
- 3. ELECTRICAL CONTRACTOR SHALL INSTALL AND WIRE ALL, LIGHT FIXTURES, LIGHTING CONTROLS, AS INDICATED ON SITE LIGHTING PLAN.

ELECTRICAL GENERAL NOTES

- 1. UPON COMPLETION OF THE JOB, IT WILL BE THE ELECTRICAL CONTRACTOR'S RESPONSIBILITY TO TURN OVER A SET OF AS-BUILT DRAWINGS TO THE OWNER IN REPRODUCIBLE FORM. THESE DRAWINGS DO NOT HAVE TO BE MADE FROM SCRATCH: THE CONTRACT SITE LIGHTING PLANS MAY BE USED AS BACKGROUNDS TO INDICATE ALL ACTUAL POLE/LIGHT, PULL BOXES, CONDUIT ROUTING AND ACTUAL CIRCUITS TO SITE LIGHTING FIXTURES.
- 2. ALL ELECTRICAL WORK MUST BE PERFORMED IN ACCORDANCE WITH AND SHALL CONFORM IN ALL ASPECTS TO THE NATIONAL ELECTRICAL CODE (NFPA CODES & LOCAL BUILDING CODES).
- 3. ALL PERMITS, LICENSES AND CERTIFICATES COVERING THE COMPLETE INSTALLATION OF ELECTRICAL WORK MUST BE OBTAINED AND PAID FOR BY ELECTRICAL CONTRACTOR. ELECTRICAL CONTRACTOR WILL BE RESPONSIBLE FOR PROVIDING ELECTRICAL PERMITS AS REQUIRED FOR ALL ELECTRICAL WORK DESCRIBED IN THE CONSTRUCTION DRAWINGS AND DOCUMENTS.
- 4. ALL CORE-BORING OR BACKFILLING AND RESURFACING REQUIRED FOR THE ELECTRICAL WORK MUST BE PROVIDED BY ELECTRICAL CONTRACTOR.
- 5. ALL CUTTING PATCHING AND REFINISHING OF WALLS, FLOORS AND CEILINGS, REQUIRED FOR THE ELECTRICAL WORK, MUST BE PROVIDED BY THE ELECTRICAL CONTRACTOR.
- 6. THESE DRAWINGS ARE DIAGRAMMATIC ONLY; EXACT LOCATIONS OF ALL CONDUIT, ETC. MUST BE FIELD DETERMINED AND RUN TO AVOID OBSTRUCTIONS.
- 7. SITE VISITATION - PRIOR TO SUBMITTING A BID FOR WORK, ELECTRICAL CONTRACTOR SHALL VISIT THE SITE TO INSPECT THE NATURE AND EXTENT OF THE EXISTING CONDITIONS AND EQUIPMENT, AND DETERMINE HOW THEY WILL AFFECT THE INSTALLATION OF ELECTRICAL WORK. NO ADDITIONAL PAYMENT, IN EXCESS OF THE CONTRACT PRICE, WILL BE AUTHORIZED FOR "EXTRA" WORK PERFORMED DUE TO EXISTING CONDITIONS WHICH ARE OBVIOUS UPON INSPECTION.
- 8. ALL EQUIPMENT AND DEVICES MUST BE NEW & BEAR UL LABEL. ALL DEVICES MUST BE "SPECIFICATION" GRADE.
- 9. WORKMANSHIP: ONLY THE BEST IN WORKMANSHIP IN ACCORDANCE WITH PRESENT STANDARDS WILL BE ACCEPTABLE. ANY WORK INSTALLED AND ADJUDGED BY THE ENGINEER TO BE BELOW STANDARDS WILL BE TAKEN OUT AND REPLACED WITH PROPERLY DONE WORK AT ELECTRICAL CONTRACTOR'S EXPENSE.
- 10. GUARANTEE: ELECTRICAL CONTRACTOR MUST GUARANTEE ALL EQUIPMENT AND WIRING TO BE FREE FROM INHERENT MECHANICAL AND ELECTRICAL DEFECTS FOR A PERIOD OF ONE YEAR FROM DATE OF SUBSTANTIAL COMPLETION OF PROJECT. ALL DEFECTS MUST BE REPAIRED, DURING THIS PERIOD, AT NO CHARGE TO OWNER (MISUSE OR ABUSE CAUSED PROBLEMS EXCEPTED).
- 11. ALL PROJECT SUBMITTALS TO BE APPROVED BY THE ENGINEER PRIOR TO INSTALLATION. SUBSTITUTIONS OF EQUIPMENT: SPECIFIED PRODUCTS MUST BE USED AS THE BASIS OF BID AND SHALL BE PROVIDED; WHERE 2 OR MORE MANUFACTURERS ARE LISTED, THE CHOICE IS AT THE ELECTRICAL CONTRACTOR'S OPTION. AN APPROVED EQUAL SHALL BE DETERMINED BY ENGINEER.
- 12. ELECTRICAL CONTRACTOR SHALL PERFORM VOLTAGE DROP CALCULATIONS FOR BRANCH CIRCUITS LONGER THAN INDICATED AND SPECIFIED ON SITE LIGHTING PLAN AS PER NEC.
- 13. ALL PENETRATIONS THROUGH FIRE RATED ASSEMBLIES MUST BE FIRE STOPPED USING FIRE RETARDANT SEALANTS APPROVED BY THE ENGINEER. ELECTRICAL CONTRACTOR MUST SEAL ALL ELECTRICAL PENETRATIONS THRU FIRE RATED PARTITIONS WITH FIRE RATED MATERIAL EQUAL TO DOW CORNING FIRESTOP 3-6548 SILICONE RTV FOAM AS A MINIMUM. MATERIAL SELECTION SHALL BE BASED ON RATING OF PARTITION PENETRATED.
- 14. ELECTRICAL CONTRACTOR MUST FIELD VERIFY NAMEPLATE LOADS OF ALL EQUIPMENT (OWNER SUPPLIED) TO INSURE PROPER WIRE SIZING AND OVER-CURRENT PROTECTION AND SHALL NOTIFY ENGINEER OF DISCREPANCIES.
- 15. ALL SUPPLEMENTARY STEEL REQUIRED FOR ELECTRICAL WORK SHALL BE PROVIDED BY ELECTRICAL CONTRACTOR.
- 16. PROVIDE INSULATED GROUNDING CONDUCTOR IN ALL CONDUITS AND CABLE ASSEMBLIES TO COMPLY WITH NEC.
- 17. ACCESS TO AND CLEARANCES AROUND ELECTRICAL EQUIPMENT SHALL CONFORM TO NEC ARTICLE 110. CONSULT ENGINEER WHERE SPACE APPEARS INADEQUATE DUE TO FIELD CONDITIONS. DO NOT COVER, OBSCURE OR BLOCK ACCESS TO EQUIPMENT, ACCESS PANELS OR MAINTENANCE AREAS WITH THE ELECTRICAL WORK.
- 18. ALL PANEL DIRECTORIES, ASSOCIATED WITH THIS PROJECT, MUST BE "TYPED" AND COMPLETELY FILLED IN AT COMPLETION OF JOB IN ACCORDANCE WITH NEC 408.4. NO HAND-WRITTEN DIRECTORIES WILL BE ALLOWED.
- 19. ELECTRICAL CONTRACTOR MUST PRODUCE A LETTER ATTESTING THAT WORK HAS BEEN COMPLETED TO THE SATISFACTION OF THE OWNER WHO WILL CONFIRM HIS ACCEPTANCE BY AFFIXING HIS SIGNATURE TO THE LETTER IN A SPACE PROVIDED FOR THIS PURPOSE. WORK WILL NOT BE CONSIDERED AS BEING COMPLETE WITHOUT THIS LETTER.
- 20. PRIOR TO THE ELECTRICAL CONTRACTOR BEING RELEASED FROM ALL OBLIGATIONS, ELECTRICAL CONTRACTOR WILL OBTAIN AND TURN OVER TO THE OWNER THE ORIGINAL COPY OF THE "CERTIFICATE OF ELECTRICAL INSPECTION".
- 21. ELECTRICAL CONTRACTOR MUST COORDINATE ALL PLANNED POWER SHUTDOWN REQUIREMENTS APPROXIMATELY 5 DAYS IN ADVANCE WITH OWNER. ELECTRICAL CONTRACTOR MUST NOT PROCEED WITH POWER SHUTDOWN WITHOUT WRITTEN AUTHORIZATION FROM OWNER.
- 22. WHERE CONFLICTS OCCUR BETWEEN DRAWINGS OR BETWEEN DRAWINGS AND SPECIFICATIONS, THE MOST RESTRICTIVE, THE MOST EXPENSIVE REQUIREMENT SHALL APPLY.

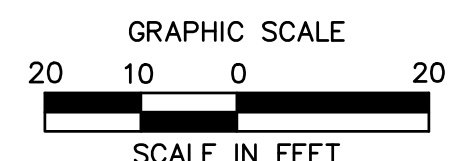

355 Research Parkway
Middletown, CT 06450
(203) 630-1406
(203) 630-2615 Fax

TENNIS COURT RENOVATION
PORTSMOUTH HIGH SCHOOL
50 ANDREW JARVIS DR., PORTSMOUTH, NH 03801

| REVISIONS | No. | Date | Desc. |
|-----------|-----|------|-------|
| | | | |

CAD File: EL2101901

Title
SITE LIGHTING PLAN

Sheet No.

EL-01

Portsmouth High School Tennis Courts
Portsmouth, NH

Lighting System

| Pole / Fixture Summary | | | | | | |
|------------------------|-------------|------------|-------------|----------------|-----------------|---------|
| Pole ID | Pole Height | Mtg Height | Fixture Qty | Luminaire Type | Load | Circuit |
| T1 | 40' | 40' | 2 | TLC-LED-600 | 1.16 kW | C |
| T2 | 40' | 40' | 2 | TLC-LED-600 | 1.16 kW | B |
| T3 | 50' | 50' | 2 | TLC-LED-600 | 1.16 kW | B |
| | 50' | 50' | 2 | TLC-LED-600 | 1.16 kW | A |
| T4, T7 | 50' | 50' | 2 | TLC-LED-600 | 1.16 kW | C |
| T5, T6 | 40' | 40' | 2 | TLC-LED-600 | 1.16 kW | A |
| T8 | 50' | 50' | 2 | TLC-LED-600 | 1.16 kW | B |
| | 50' | 50' | 2 | TLC-LED-600 | 1.16 kW | C |
| 8 | | | 24 | | 13.92 kW | |

| Circuit Summary | | | |
|-----------------|-------------|---------|-------------|
| Circuit | Description | Load | Fixture Qty |
| A | Tennis 1-2 | 4.64 kW | 8 |
| B | Tennis 3-4 | 4.64 kW | 8 |
| C | Tennis 5-6 | 4.64 kW | 8 |

| Fixture Type Summary | | | | | | | |
|----------------------|--------------------|---------|--------|----------|----------|----------|----------|
| Type | Source | Wattage | Lumens | L90 | L80 | L70 | Quantity |
| TLC-LED-600 | LED 5700K - 75 CRI | 580W | 65,600 | >120,000 | >120,000 | >120,000 | 24 |

Light Level Summary

| Calculation Grid Summary | | | | | | | |
|--------------------------|------------------------|------|-----|-----|---------|---------|-------------|
| Grid Name | Calculation Metric | Avg | Min | Max | Max/Min | Upl/Min | Fixture Qty |
| Tennis 1-2 | Horizontal Illuminance | 34.4 | 27 | 47 | 1.75 | 1.28 | 8 |
| Tennis 3-4 | Horizontal Illuminance | 35 | 27 | 48 | 1.75 | 1.29 | 8 |
| Tennis 5-6 | Horizontal Illuminance | 35.7 | 27 | 45 | 1.67 | 1.32 | 8 |

From Hometown to Professional

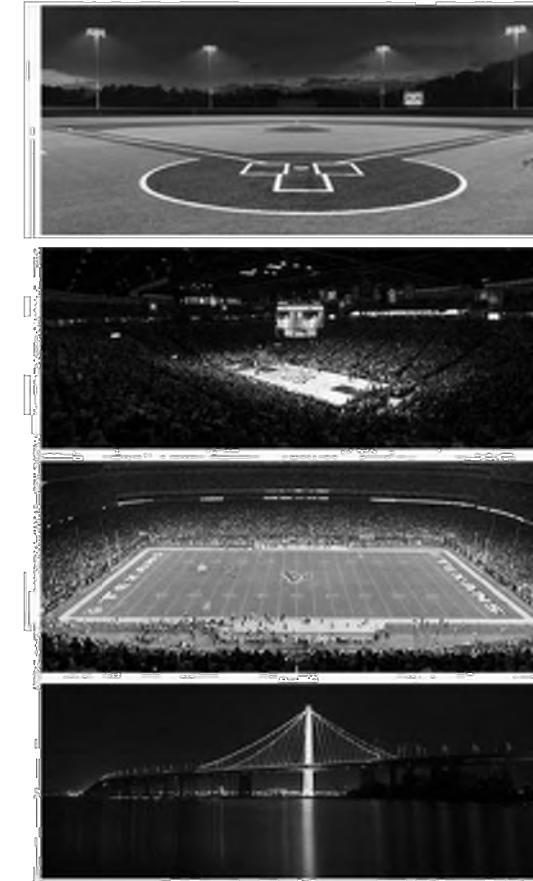

Not to be reproduced in whole or part without the written consent of Musco Sports Lighting, LLC. ©1981, 2022 Musco Sports Lighting, LLC.

PROJECT SUMMARY

ENGINEERED DESIGN By: File #211130E - 19-Dec-22

| EQUIPMENT LIST FOR AREAS SHOWN | | | | | | | | | |
|--------------------------------|---------------|------|-----------------|------------------|----------------|------------|-----------|------------|-------------|
| QTY | LOCATION | SIZE | GRADE ELEVATION | RECURRING HEIGHT | LUMINAIRE TYPE | QTY / POLE | TYPE GRID | OTHER GRID | OTHER NOTES |
| 1 | T1 | 50' | - | 50' | TLC-LED-600 | 4 | 2 | 2 | |
| 2 | T5-T6 | 40' | - | 40' | TLC-LED-600 | 2 | 2 | 0 | |
| 4 | T8 | 50' | - | 50' | TLC-LED-600 | 24 | 2 | 0 | |
| | TOTALS | | | | | 34 | 8 | 6 | |

* This structure utilizes a back-to-back mounting configuration

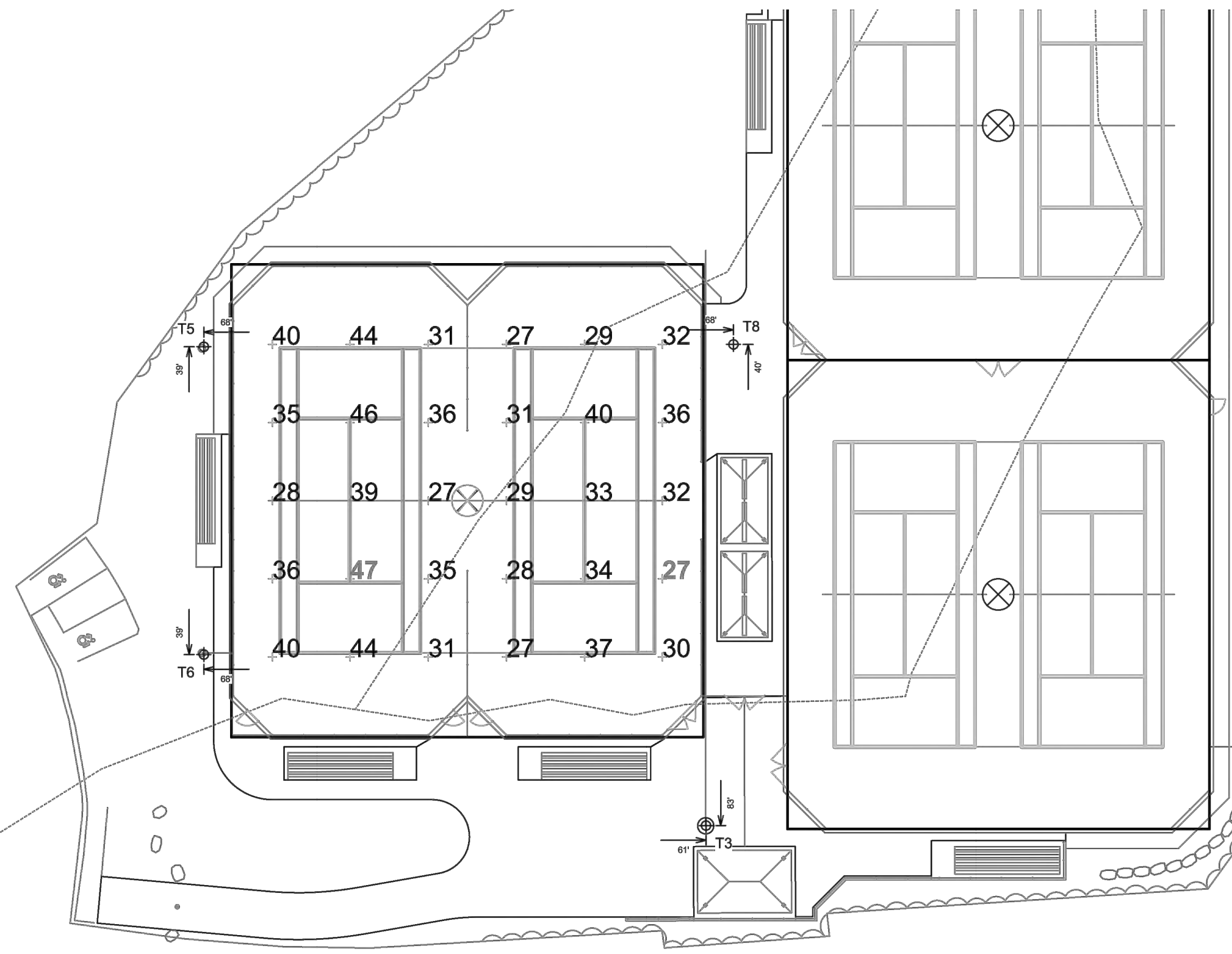

SCALE IN FEET 1 : 30
0 30 60

ENGINEERED DESIGN By: File #211130E - 19-Dec-22

Portsmouth High School Tennis Courts
Portsmouth, NH

| GRID SUMMARY | |
|--------------|-----------------------|
| Name: | Tennis 1-2 |
| Size: | 2 Court - 24' Spacing |
| Spacing: | 20.0' x 20.0' |
| Height: | 3.0' above grade |

| ILLUMINATION SUMMARY | |
|-----------------------|-------|
| Entire Grid | |
| Guaranteed Average: | 30 |
| Scan Average: | 34.43 |
| Maximum: | 47 |
| Minimum: | 27 |
| Avg / Min: | 1.29 |
| Guaranteed Max / Min: | 2.8 |
| Max / Min: | 1.75 |
| UG (adjacent pts): | 0.00 |
| CU: | 0.79 |
| No. of Points: | 30 |

| LUMINAIRE INFORMATION | |
|-----------------------|---------|
| Applied Circuits: | A |
| No. of Luminaires: | 8 |
| Total Load: | 4.64 kW |

Guaranteed Performance: The ILLUMINATION described above is guaranteed per your Musco Warranty document and includes a 0.95 dirt depreciation factor.
Field Measurements: Individual field measurements may vary from computer-calculated predictions and should be taken in accordance with IESNA RP-6-15.
Electrical System Requirements: Refer to Amperage Draw Chart and/or the "Musco Control System Summary" for electrical sizing.
Installation Requirements: Results assume a 3% nominal voltage at the side of the driver and structures located within 3 feet (1m) of design locations.



Not to be reproduced in whole or part without the written consent of Musco Sports Lighting, LLC. ©1981, 2022 Musco Sports Lighting, LLC.

ILLUMINATION SUMMARY

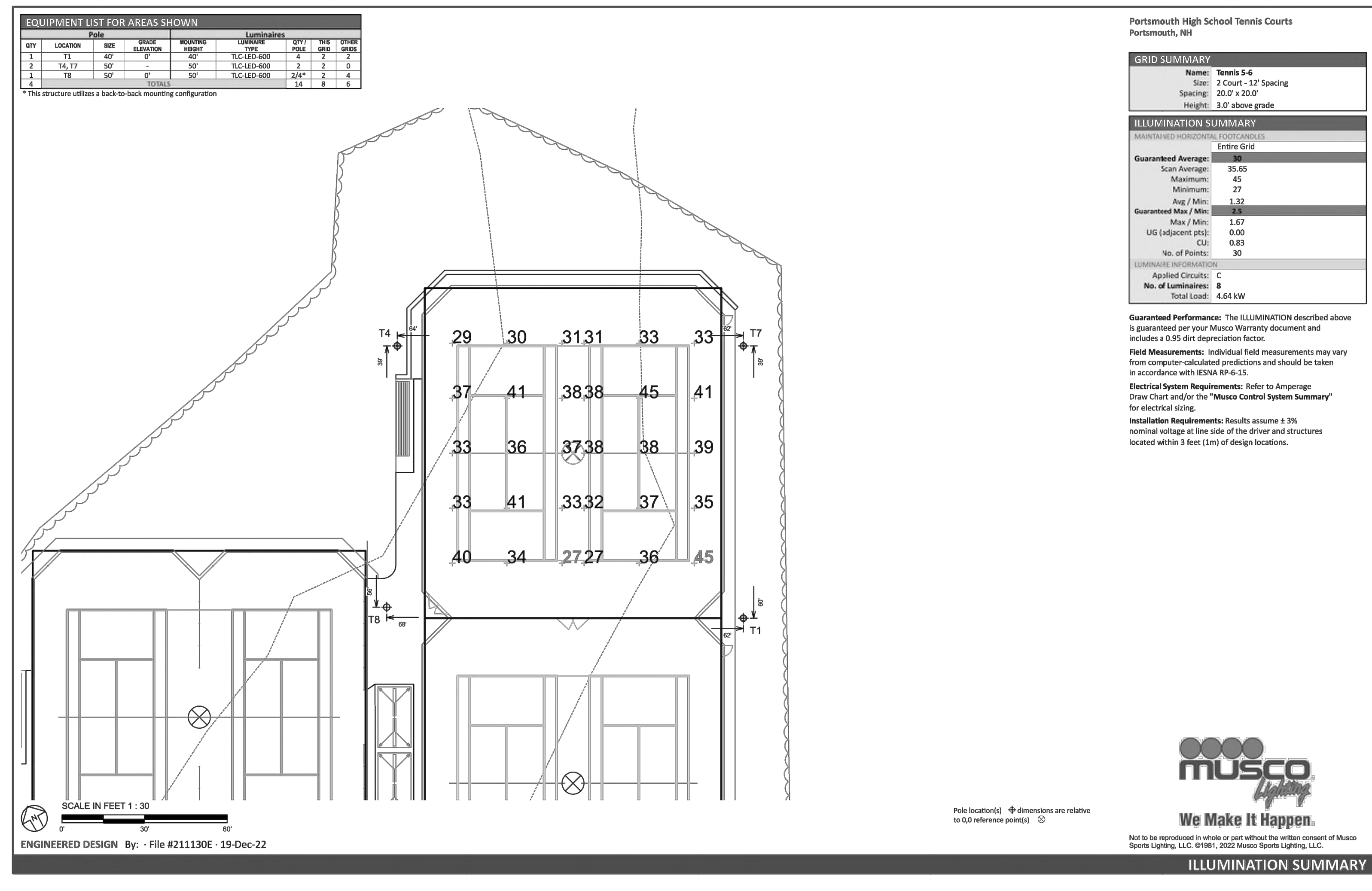
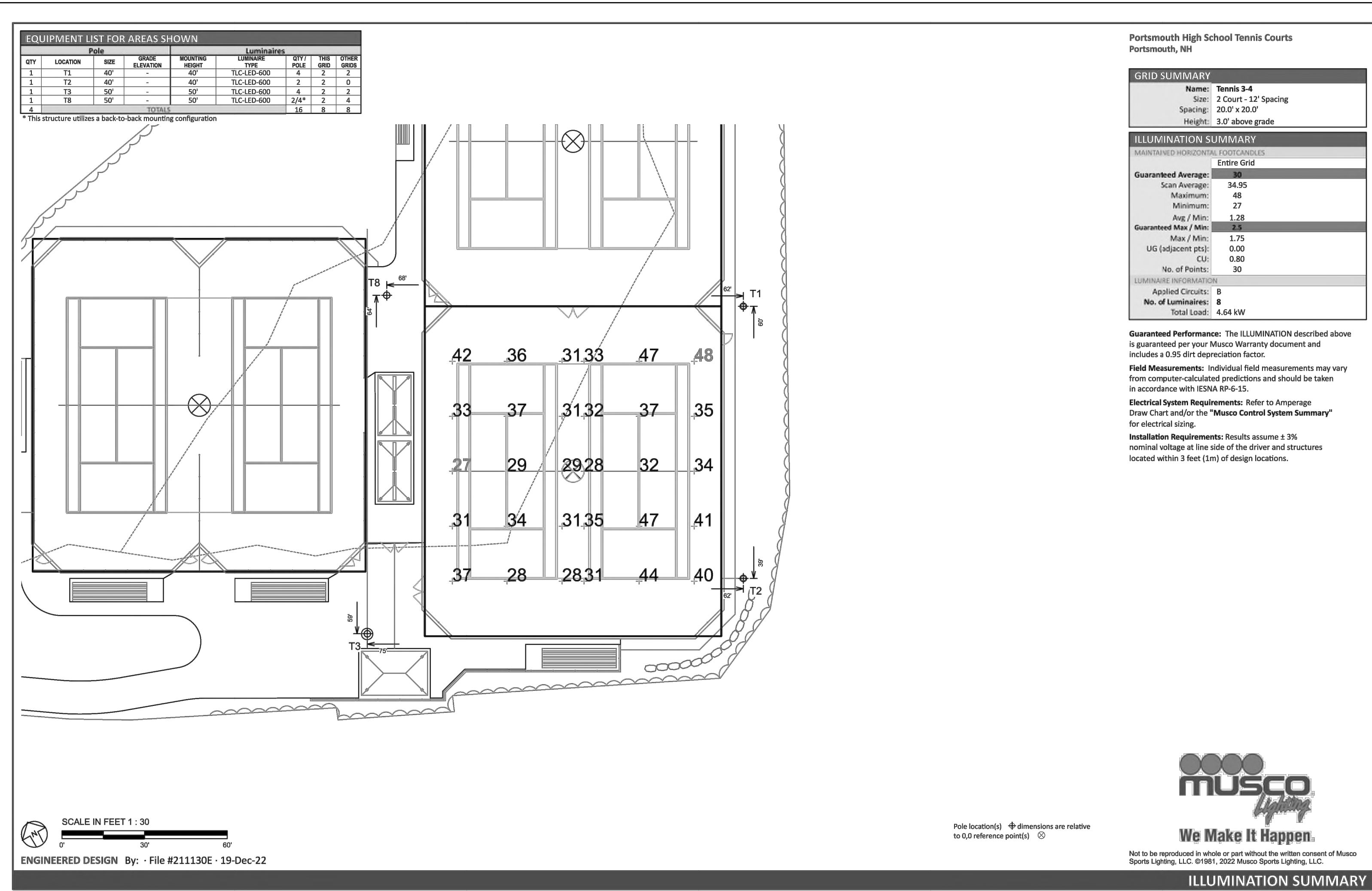

Jan 11, 2022, 2:05pm jwhester C:\Users\jwhester\OneDrive\Documents\EL210192001.dwg
 Layout: EL-05

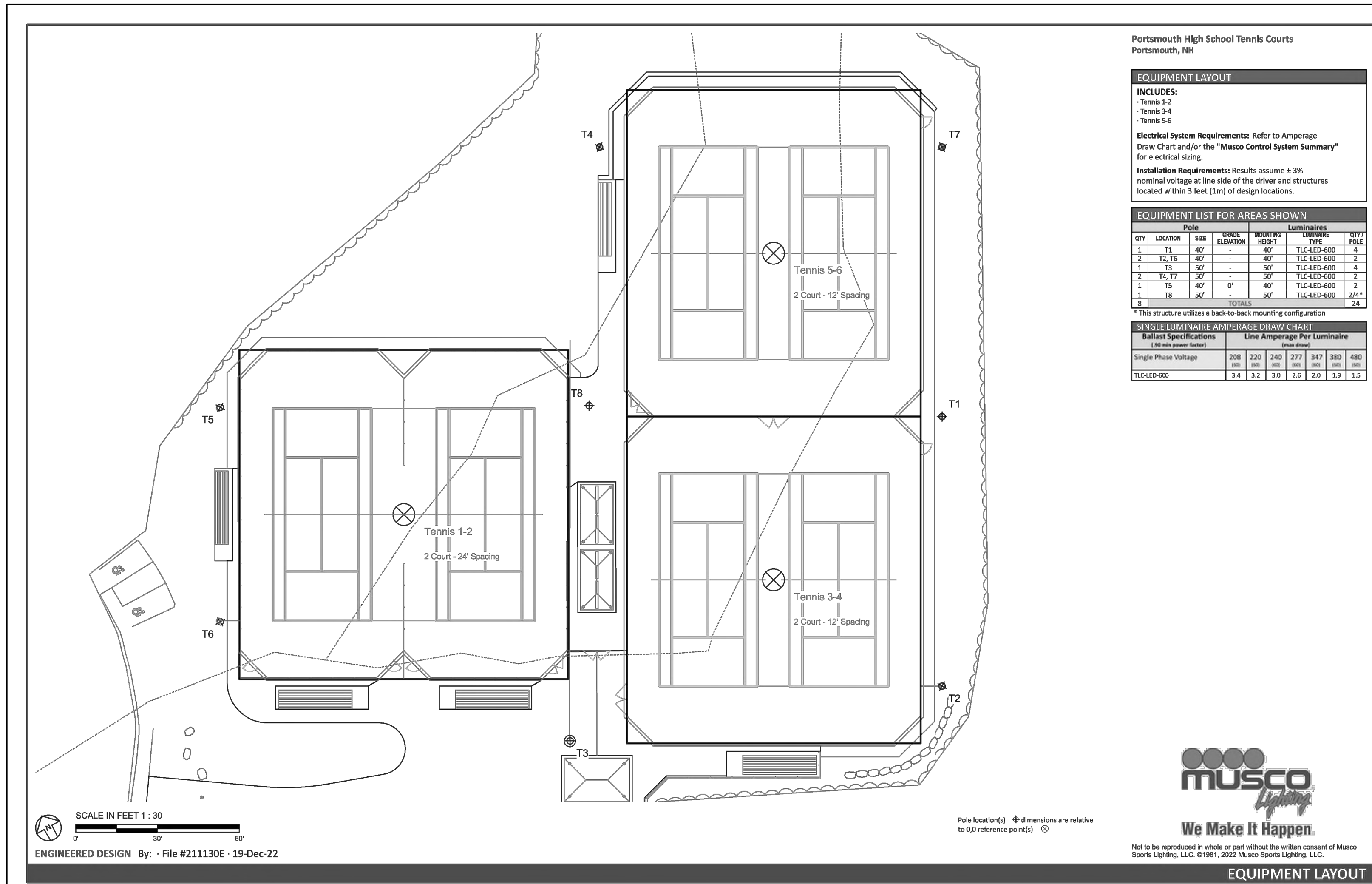

Portsmouth High School Tennis Courts
 Portsmouth, NH

EQUIPMENT LAYOUT

INCLUDES:
 - Tennis 1-2
 - Tennis 3-4
 - Tennis 5-6

Electrical System Requirements: Refer to Amperage Draw Chart and/or the "Musco Control System Summary" for electrical sizing.
 Installation Requirements: Results assume a 3% nominal voltage at line side of the driver and structures located within 3 feet (1m) of design locations.

EQUIPMENT LIST FOR AREAS SHOWN

| QTY | LOCATION | SIZE | ORICE | HEIGHT | Luminaire Type | POLE |
|---|----------|------|-------|--------|----------------|------|
| 1 | T1 | 40' | - | 40' | TLC-LED-600 | 4 |
| 2 | T2, T5 | 40' | - | 40' | TLC-LED-600 | 2 |
| 1 | T3 | 50' | - | 50' | TLC-LED-600 | 4 |
| 2 | T4, T7 | 50' | - | 50' | TLC-LED-600 | 2 |
| 1 | T5 | 40' | 0' | 40' | TLC-LED-600 | 2 |
| 1 | T8 | 50' | - | 50' | TLC-LED-600 | 2/4* |
| TOTALS | | | | | | |
| * This structure utilizes a back-to-back mounting configuration | | | | | | |

SINGLE LUMINAIRE AMPERAGE DRAW CHART

| Ballast Specifications | Line Amperage Per Luminaire | | | | | |
|------------------------|-----------------------------|----------|----------|----------|----------|----------|
| (480v power factor) | Line Voltage | Line Amp | Line Amp | Line Amp | Line Amp | Line Amp |
| Single Phase Voltage | 208 | 220 | 240 | 277 | 347 | 480 |
| TLC-LED-600 | 3.4 | 3.2 | 3.0 | 2.6 | 2.0 | 1.5 |

MUSCO Lighting
 We Make It Happen.

Not to be reproduced in whole or part without the written consent of Musco Sports Lighting, LLC. ©1991, 2022 Musco Sports Lighting, LLC.

EQUIPMENT LAYOUT

POLE FOUNDATION SCHEDULE

| POLE DESIGNATION | FORCES (1) | | | DRILLED PIER | | | |
|------------------|-------------------|---------------|------------------|---------------------|---------------------|--------------------|---------------------------------------|
| | MOMENT (M) FT-LBS | SHEAR (V) LBS | VERTICAL (P) LBS | DIAMETER INCHES | EMBEDMENT DEPTH (4) | SUSPENSION "Y" (2) | CONCRETE BACKFILL YD ³ (3) |
| T1 | 20,622 | 752 | 611 | 36 | 10'-0" | 2'-0" | 2.0 |
| T2, T5, T6 | 14,469 | 591 | 481 | 36 | 10'-0" | 2'-0" | 2.0 |
| T3 | 33,942 | 1,071 | 905 | EXISTING FOUNDATION | | | |
| T4, T7 | 23,300 | 762 | 545 | 36 | 8'-0" | NA | 1.5 |
| T8 | 42,974 | 1,257 | 1,028 | 36 | 12'-0" | 2'-0" | 2.6 |

DESIGN NOTES

DESIGN PARAMETERS:
 WIND: V_w = 130 MPH, V_{avg} = 101 MPH (EXPOSURE C, RISK CATEGORY II) PER INTERNATIONAL BUILDING CODE, 2015 EDITION (ASCE 7-10). DESIGN WIND PARAMETERS ARE AS NOTED. ACTUAL EXPOSURE MUST BE VERIFIED FOR THE SITE BY THE PROPER GOVERNING OFFICIAL.

GEOTECHNICAL PARAMETERS:
 ALLOWABLE END BEARING SOIL PRESSURE: 4,000 PSF
 LATERAL SOIL RESISTANCE PARAMETERS:
 AS PROVIDED IN WESTON & SAMPSON REPORT, PAGE 4 IN ACCORDANCE WITH THE 2015 EDITION OF THE INTERNATIONAL BUILDING CODE, CHAPTER 18.

DESIGN SOIL PARAMETERS ARE AS NOTED. ACTUAL ALLOWABLE SOIL PARAMETERS MUST BE VERIFIED ON SITE. REFERENCE GEOTECHNICAL ENGINEERING REPORT (11/11/2015), PROJECT NO. 2140758.K, BY WESTON & SAMPSON, AND BORING LOGS B-101/B-102 (12/7/2021), PROJECT NO. 2104563, BY GEI CONSULTANTS.

A GEOTECHNICAL ENGINEER OR REPRESENTATIVE OF IS RECOMMENDED (NOT REQUIRED) TO BE AVAILABLE AT THE TIME OF THE FOUNDATION INSTALLATION TO VERIFY THE SOIL DESIGN PARAMETERS AND TO PROVIDE ASSISTANCE IF ANY PROBLEMS ARISE IN FOUNDATION INSTALLATION.

ENCOUNTERING SOIL FORMATIONS THAT WILL REQUIRE SPECIAL DESIGN CONSIDERATIONS OR EXCAVATION PROCEDURES MAY OCCUR. POLE FOUNDATIONS WILL NEED TO BE ANALYZED ACCORDING TO THE SOIL CONDITIONS THAT EXIST. IF ANY DISCREPANCIES OR INCONSISTENCIES ARISE, NOTIFY THE ENGINEER OF SUCH DISCREPANCIES. FOUNDATIONS WILL THEN BE REVISED ACCORDINGLY. REVISIONS WILL BE ANALYZED PER RECOMMENDATIONS DIRECTED BY A REGISTERED ENGINEER.

CONTRACTOR MUST BE FAMILIAR WITH THE COMPLETE SOIL INVESTIGATION REPORT AND BORINGS, AND CONTACT THE GEOTECHNICAL FIRM (IF NECESSARY) TO UNDERSTAND THE SOIL CONDITIONS AND THE POSSIBILITY OF GROUND WATER PUMPING AND EXCAVATION STABILIZATION OR BRACING DURING PRECAST BASE INSTALLATION AND PLACEMENT OF CONCRETE BACKFILL.

CONCRETE:
 CONCRETE SHALL BE AIR-ENTRAINED AND HAVE A MINIMUM COMPRESSIVE DESIGN STRENGTH AT 28 DAYS OF 5,000 PSI. 5,000 PSI CONCRETE SPECIFIED FOR EARLY POLE ERECTION. ACTUAL REQUIRED MINIMUM ALLOWABLE CONCRETE STRENGTH IS 1,000 PSI. ALL PIERS AND CONCRETE BACKFILL MUST BEAR ON AND AGAINST FIRM UNDISTURBED SOIL.

GENERAL NOTES:
 FIXTURES MUST BE LOCATED TO MAINTAIN 10'-0" MINIMUM HORIZONTAL CLEARANCE FROM ANY OBSTRUCTION. ENGINEER MUST BE NOTIFIED IF FOUNDATIONS ARE NEAR ANY RETAINING WALLS OR WITHIN / NEAR ANY SLOPES STEEPER THAN 3H: 1V. POLES, FIXTURES, PRECAST BASES, ELECTRICAL ITEMS AND INSTALLATION PER MUSCO LIGHTING.

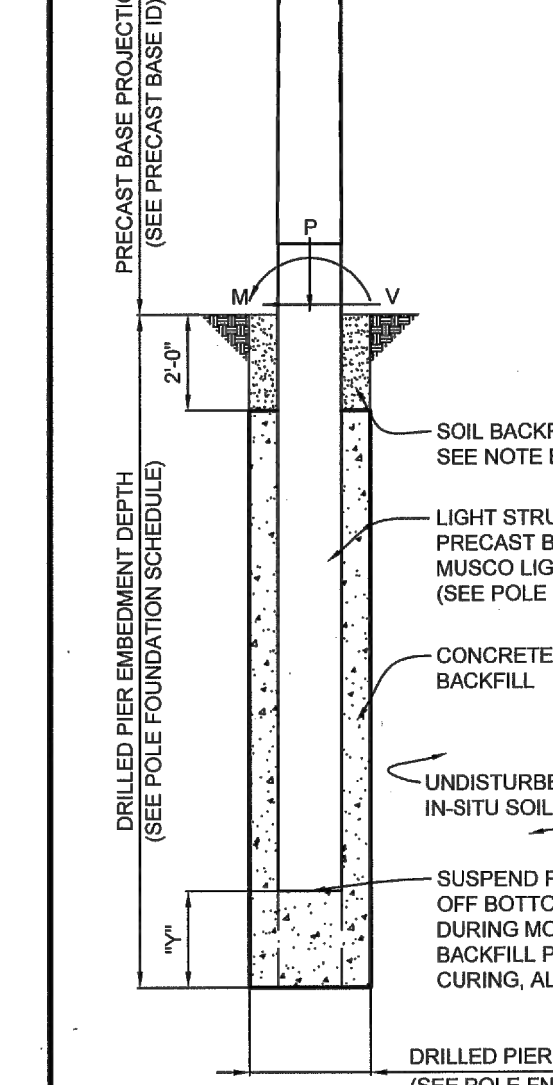

- ASD LOAD COMBINATION D + 0.6W. VERTICAL FORCE IS WEIGHT OF DRESSED POLE (DOES NOT INCLUDE PRECAST BASE WEIGHT)
- SUSPEND PRECAST BASE "Y" OFF THE BOTTOM OF THE EXCAVATION DURING MONOLITHIC CONCRETE BACKFILL PLACEMENT AND CURING. NA = NOT APPLICABLE, SUSPENSION NOT REQUIRED.
- MINIMUM CONCRETE BACKFILL VOLUME, SITE CONDITIONS MAY REQUIRE ADDITIONAL BACKFILL.
- POTENTIAL FOR ENCOUNTERING ROCK BEFORE REACHING EMBEDMENT DEPTH. ROCK AUGERING EQUIPMENT MAY BE REQUIRED.

PRECAST BASE IDENTIFICATION

| PRECAST BASE TYPE | PRECAST BASE WEIGHT | PRECAST BASE LENGTH | PROJECTION ABOVE GRADE | STANDARD EMBEDMENT | OUTSIDE DIAMETER |
|-------------------|---------------------|---------------------|------------------------|--------------------|------------------|
| 1B | 920 LBS | 15'-2" | 7'-2" | 8'-0" | 9.56" |
| 2B | 1,690 LBS | 17'-3" | 7'-3" | 10'-0" | 12.00" |

POLE IDENTIFICATION

| POLE DESIGNATION | POLE TYPE | PRECAST BASE TYPE | FIXTURE CONFIGURATION (FIX. PER XARM) | FIXTURE AND ACCESSORIES EPA (F/F) |
|------------------|-----------|-------------------|---------------------------------------|-----------------------------------|
| T1 | LSS40A | 1B | 4 (4) | 7.7 |
| T2, T5, T6 | LSS40A | 1B | 2 (2) | 4.2 |
| T3 | LSS50AB | 2B | 4 (4) | 8.5 |
| T4, T7 | LSS50A | 1B | 2 (2) | 4.4 |
| T8 | LSS50AB | 2B | 6 (2) / (4) | 12.7 |

CONCRETE:
 CONCRETE SHALL BE AIR-ENTRAINED AND HAVE A MINIMUM COMPRESSIVE DESIGN STRENGTH AT 28 DAYS OF 5,000 PSI. 5,000 PSI CONCRETE SPECIFIED FOR EARLY POLE ERECTION. ACTUAL REQUIRED MINIMUM ALLOWABLE CONCRETE STRENGTH IS 1,000 PSI. ALL PIERS AND CONCRETE BACKFILL MUST BEAR ON AND AGAINST FIRM UNDISTURBED SOIL.

GENERAL NOTES:
 FIXTURES MUST BE LOCATED TO MAINTAIN 10'-0" MINIMUM HORIZONTAL CLEARANCE FROM ANY OBSTRUCTION. ENGINEER MUST BE NOTIFIED IF FOUNDATIONS ARE NEAR ANY RETAINING WALLS OR WITHIN / NEAR ANY SLOPES STEEPER THAN 3H: 1V. POLES, FIXTURES, PRECAST BASES, ELECTRICAL ITEMS AND INSTALLATION PER MUSCO LIGHTING.

I HEREBY CERTIFY THAT THIS ENGINEERING DOCUMENT WAS PREPARED BY ME OR UNDER MY DIRECT PERSONAL SUPERVISION AND THAT I AM A DULY LICENSED PROFESSIONAL ENGINEER UNDER THE LAWS OF THE STATE OF NEW HAMPSHIRE.

Kyle G. Lagina
 KYLE G. LAGINA
 No. 13331
 LICENSED PROFESSIONAL ENGINEER

DATE: 12-23-2022
 KYLE G. LAGINA - No. 13831
 SEPC OF IOWA - 1427

LICENSE RENEWAL DATE: NOVEMBER 30, 2023
 DRAWING NO. COVERED BY THIS SEAL: C1

**PORTSMOUTH HS
 TENNIS COURTS
 ATHLETIC LIGHTING
 PORTSMOUTH, NH**

MUSCO Lighting
 CORP., 100 W. AVE. WEST
 OSWALDO, IA 52577
 (800) 853-6520

SEPC OF IOWA
 114 NICHOLAS DRIVE
 MARSHALLTOWN, IOWA 50119
 (515) 281-1100
 EMAIL: INSU.INFO@SEPC.IA

DRAWING TITLE:
 POLE AND FOUNDATION
 SCALE: AS SHOWN

PROJECT NUMBER:
 211130

DATE:
 23 DECEMBER 2022

DRAWING NUMBER:
 C1

OF ONE

POLE FOUNDATION ELEV.
 SCALE: NOT TO SCALE

SOIL BACKFILL NOTE:
 THE TOP TWO FEET OF ANNULUS SHALL BE BACKFILLED WITH SOIL WITH A CLASSIFICATION OF CLASS 5 (TABLE 1806.2) OR BETTER. COMPACTION, 95% FOR COHESIVE SOIL AND 98% FOR A COHESIONLESS SOIL BASED UPON STANDARD PROCTOR TESTING (ASTM D698).

USE OR REPRODUCTION OF THIS INFORMATION OTHER THAN ITS INTENDED PURPOSE FOR THIS PROJECT IS PROHIBITED WITHOUT WRITTEN CONSENT FROM MUSCO SPORTS LIGHTING, LLC.



ARCHITECTURE
 ENGINEERING
 ENVIRONMENTAL
 LAND SURVEYING

355 Research Parkway
 Meriden, CT 06450
 (203) 630-1406
 (203) 630-2615 Fax

TENNIS COURT RENOVATION
 PORTSMOUTH HIGH SCHOOL
 50 ANDREW JARVIS DR., PORTSMOUTH, NH 03801

Desc.
 No.
 Date
 REVISIONS

Surveyed
 Drawn
 Reviewed
 Scale
 Project No.
 Date

CAD File: EL2101920
 Title
MUSCO LIGHTING LAYOUT 3

Sheet No.

EL-05



MATERIALS PLAN LEGEND

| SYMBOL | NAME |
|--------|----------------------------------|
| | CHAIN LINK FENCE |
| | LIMIT OF DISTURBANCE |
| | 5' WIDE CRUSHED STONE PERIMETER |
| | CONCRETE PAD |
| | BITUMINOUS PAVEMENT |
| | DOUBLE FENCE GATE |
| | SINGLE FENCE GATE |
| | 21' THREE ROW BLEACHERS |
| | EXISTING RELOCATED LIGHT FIXTURE |
| | PROPOSED LIGHT FIXTURE |
| | EXISTING LIGHT FIXTURE TO REMAIN |
| | PROPOSED TREE LINE |
| | ADA HANDICAP PARKING SPACE AISLE |

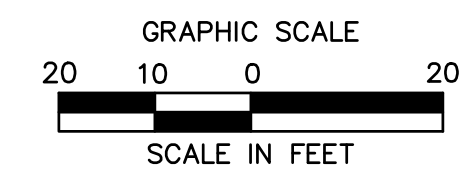
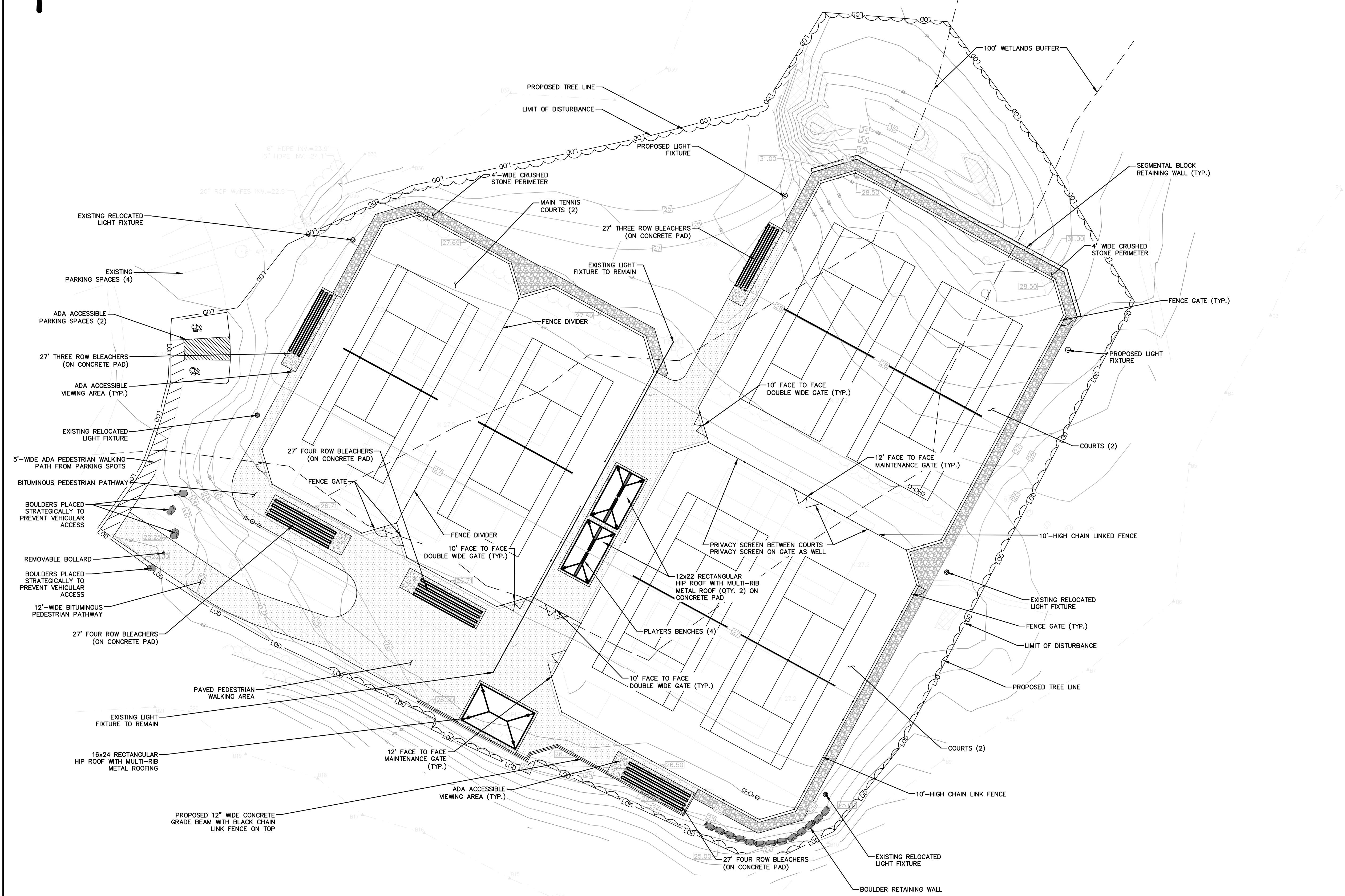

355 Research Parkway
Middletown, CT 06450
(203) 630-1406
(203) 630-2615 Fax

TENNIS COURT RENOVATION
PORTSMOUTH HIGH SCHOOL
50 ANDREW JARVIS DR., PORTSMOUTH, NH 03801

| REVISIONS | Desc. |
|-------------|------------|
| No. | Date |
| Surveyed | |
| Drawn | K.K. |
| Reviewed | |
| Scale | 1"=20'-0" |
| Project No. | 2101920 |
| Date | 01/03/2023 |

CAD File:
Title
SITE MATERIALS PLAN
Sheet No.

SM-01

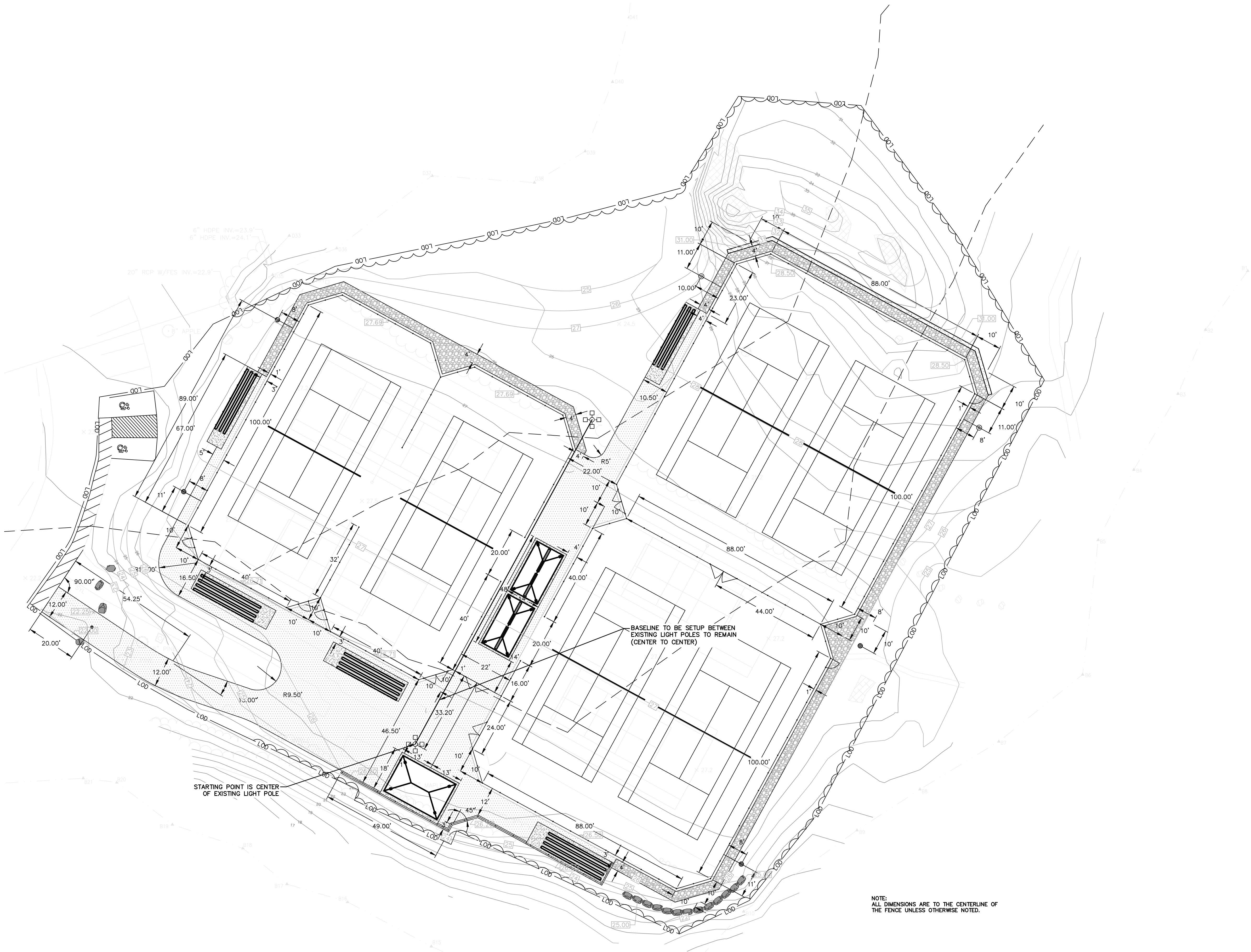

MATERIALS PLAN LEGEND

| SYMBOL | NAME |
|--------|----------------------------------|
| | CHAIN LINK FENCE |
| | LIMIT OF DISTURBANCE |
| | 5' WIDE CRUSHED STONE PERIMETER |
| | CONCRETE PAD |
| | BITUMINOUS PAVEMENT |
| | DOUBLE FENCE GATE |
| | SINGLE FENCE GATE |
| | 21' THREE ROW BLEACHERS |
| | EXISTING RELOCATED LIGHT FIXTURE |
| | PROPOSED LIGHT FIXTURE |
| | EXISTING LIGHT FIXTURE TO REMAIN |
| | PROPOSED TREE LINE |
| | ADA HANDICAP PARKING SPACE AISLE |



355 Research Parkway
Merriden, CT 06450
(203) 630-1406
(203) 630-2615 Fax

TENNIS COURT RENOVATION
PORTSMOUTH HIGH SCHOOL
50 ANDREW JARVIS DR., PORTSMOUTH, NH 03801

| REVISIONS | Desc. |
|-------------|------------|
| No. | Date |
| Surveyed | |
| Drawn | JW |
| Reviewed | JW |
| Scale | 1"=20'-0" |
| Project No. | 2101920 |
| Date | 01/03/2023 |

CAD File:
Title:
SITE LAYOUT PLAN
Sheet No.:

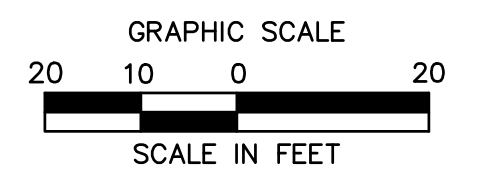

SL-01

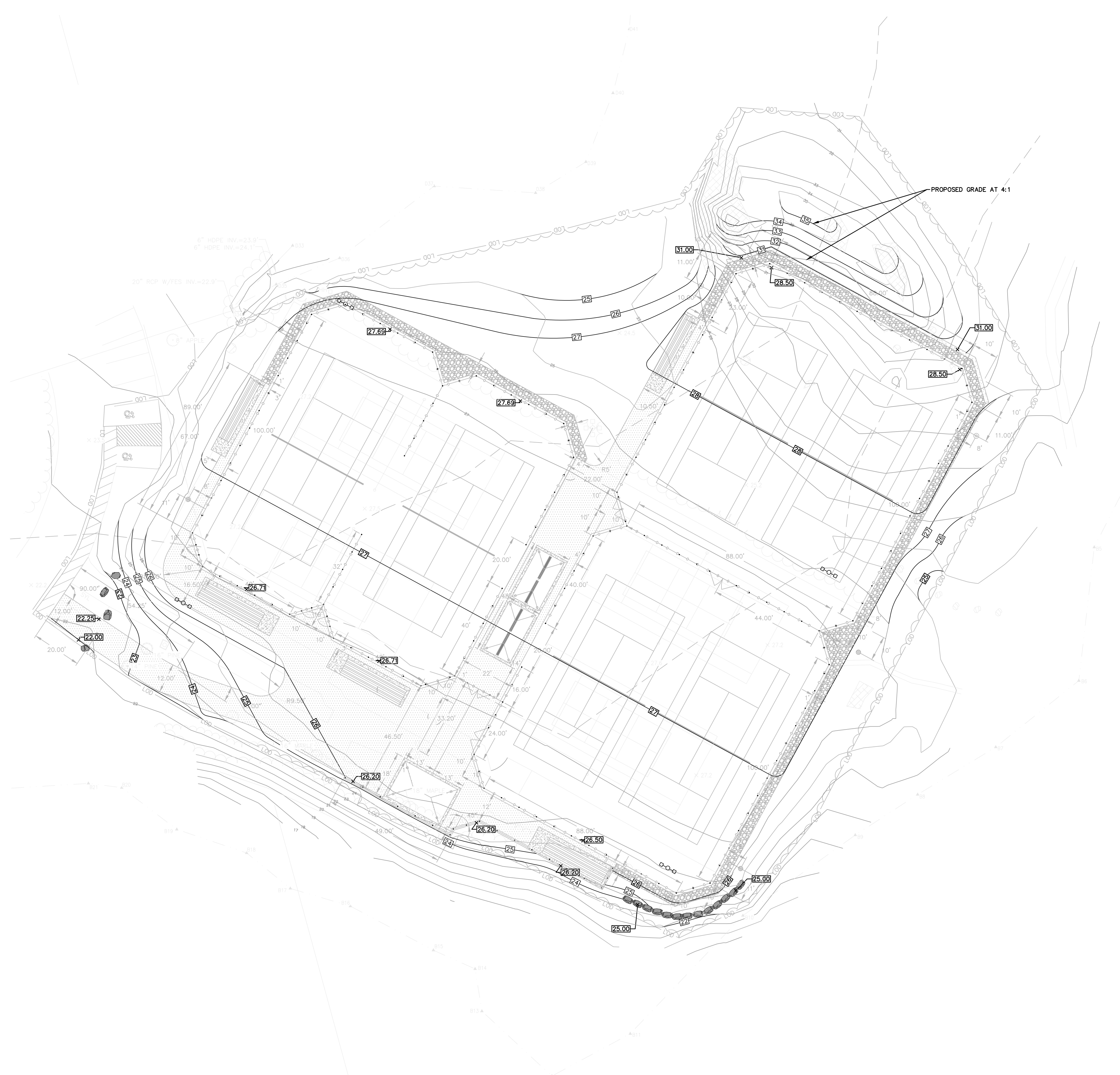

GRADING LEGEND:

| SYMBOL | NAME |
|--------|--|
| | LIMIT OF DISTURBANCE/CONTRACT LIMIT LINE |
| | PROPOSED CONTOUR LINES (1 FT INTERVALS) |
| | PROPOSED SPOT GRADES |

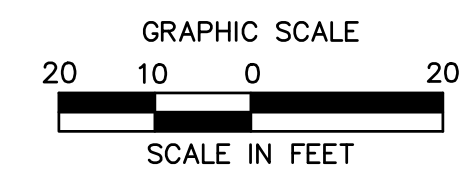

ARCHITECTURE
ENGINEERING
ENVIRONMENTAL
LAND SURVEYING

355 Research Parkway
Meriden, CT 06450
(203) 630-1406
(203) 630-2615 Fax

TENNIS COURT RENOVATION
PORTSMOUTH HIGH SCHOOL
50 ANDREW JARVIS DR., PORTSMOUTH, NH 03801

REVISIONS
No. Date

Surveyed
Drawn JW
Reviewed DC
Scale 1"=20'-0"
Project No. 2101920
Date 01/03/2023

CAD File:

Title

**SITE GRADING
PLAN**

Sheet No.

GD-01

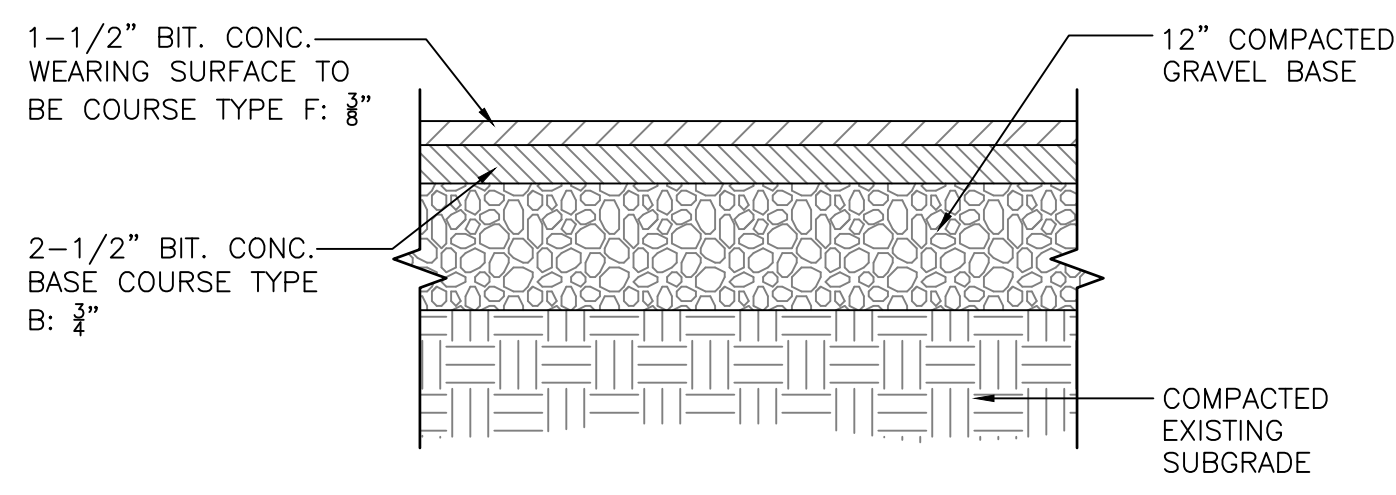

BITUMINOUS CONCRETE PAVEMENT

SCALE: N.T.S.

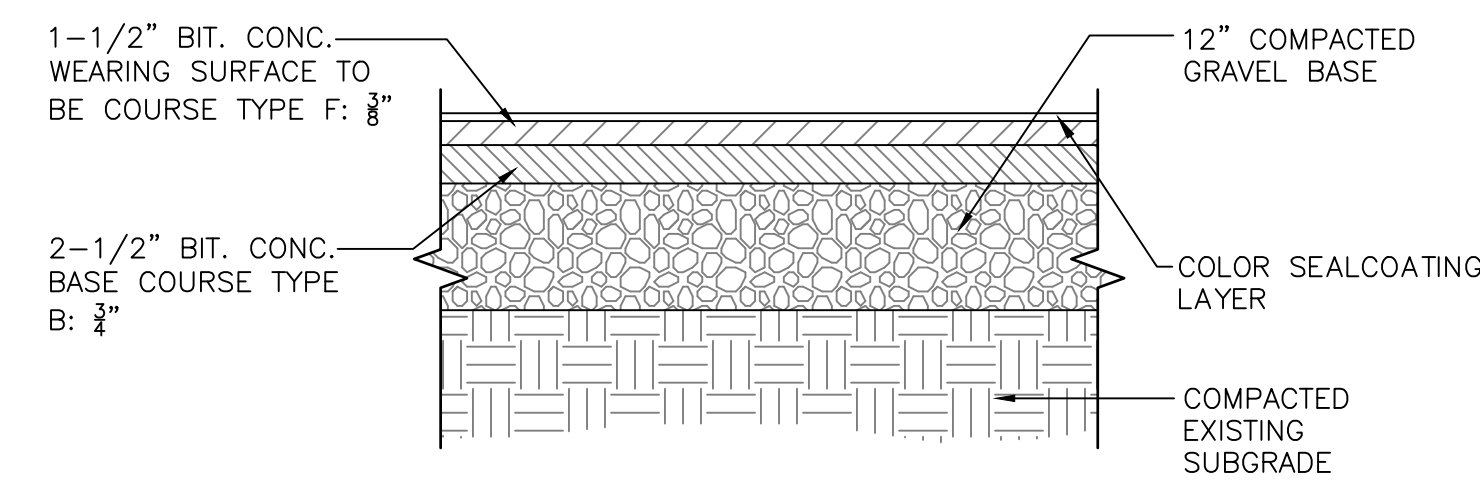

BITUMINOUS CONCRETE PAVEMENT FOR TENNIS COURTS

SCALE: N.T.S.

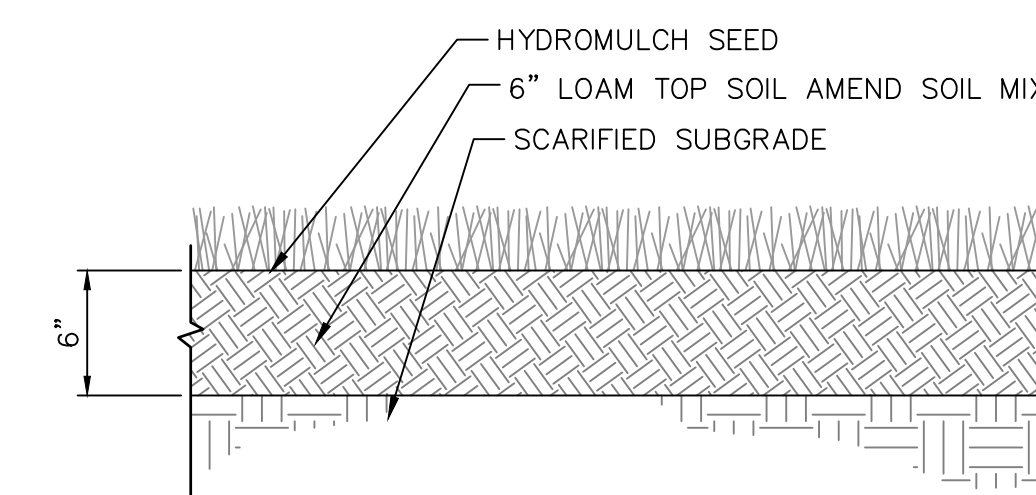

LOAM AND SEED, TYP.

SCALE N.T.S.

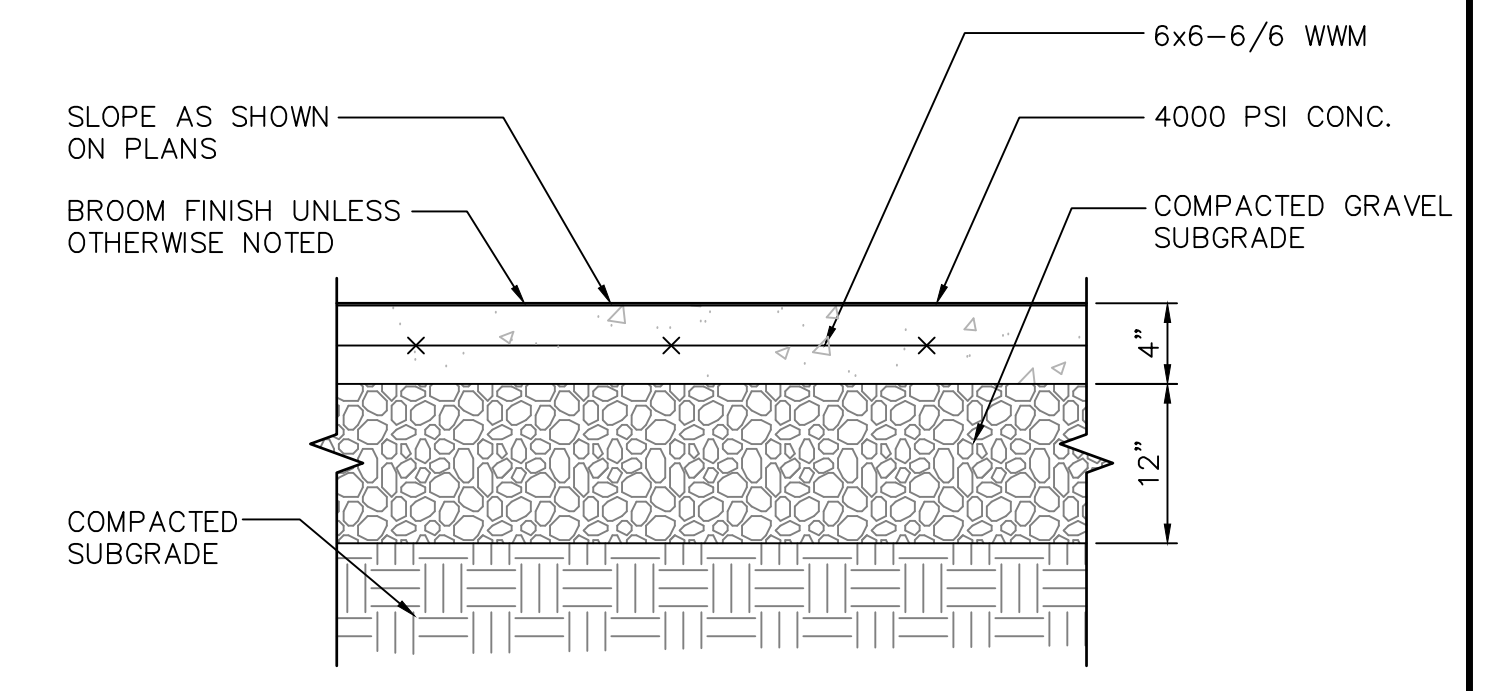

CONCRETE PAD

SCALE: NTS

NOTE:
SEE DETAIL SHEETS FOR CONTROL JOINT
DETAIL AND EXPANSION JOINT DETAIL.

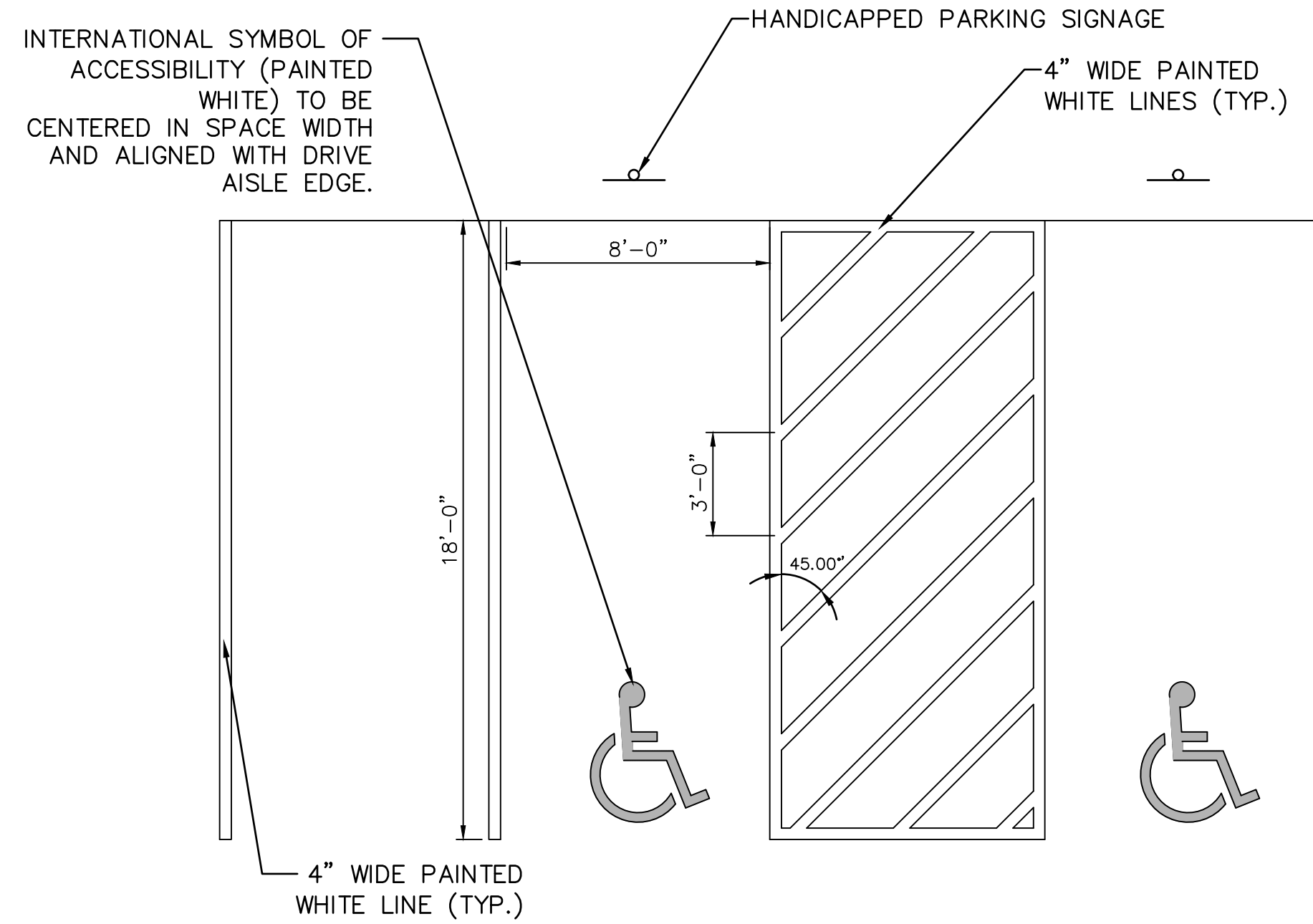

- NOTE:**
1. ALL PAINT SHALL BE FAST DRYING TRAFFIC PAINT, MEETING THE REQUIREMENTS OF AASHTO M248 TYPE F, PAINT SHALL BE APPLIED AS SPECIFIED BY THE MANUFACTURER.
 2. SYMBOLS & PARKING STALLS SHALL CONFORM TO THE REQUIREMENTS OF THE AMERICAN DISABILITIES ACT AND THE MANUAL ON UNIFORM TRAFFIC CONTROL DEVICES (MUTCD), LATEST EDITION, AND THE STATE OF NEW HAMPSHIRE BUILDING CODE.
 3. THE MINIMUM DIMENSIONS ARE SHOWN. STATE REGULATORS MAY REQUIRE LARGER DIMENSIONS.
 4. APPLY 2 COATS OF TRAFFIC PAINT. ALLOW FOR MINIMUM CURE TIME OF 24 HOURS BETWEEN APPLICATIONS.

RESERVED HANDICAPPED PARKING STALL STRIPING

SCALE: N.T.S.

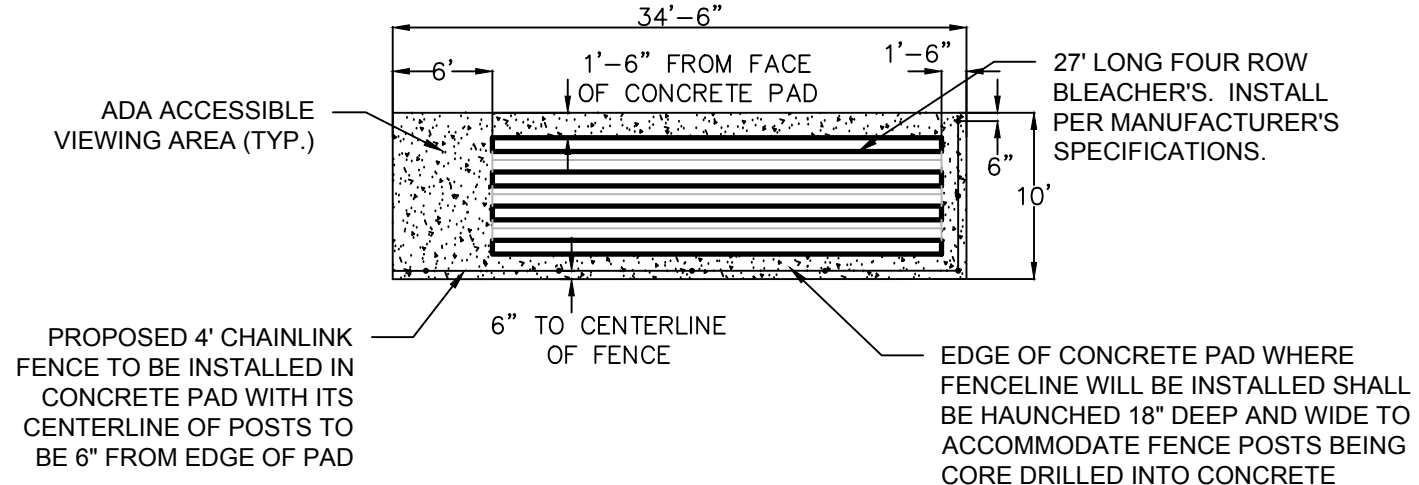

27' FOUR ROW BLEACHER ON CONCRETE PAD WITH FENCING

SCALE: NTS

- NOTES:**
1. ORIENTATION OF BLEACHERS ARE TO FACE TOWARDS TENNIS COURTS.
 2. INSTALL BLEACHERS TO CONCRETE PAD PER MANUFACTURER'S SPECIFICATIONS.
 3. SEE PLAN FOR LOCATION OF ADA VIEWING AREA, MAY CHANGE SIDES BASED ON LOCATION OF BLEACHERS.

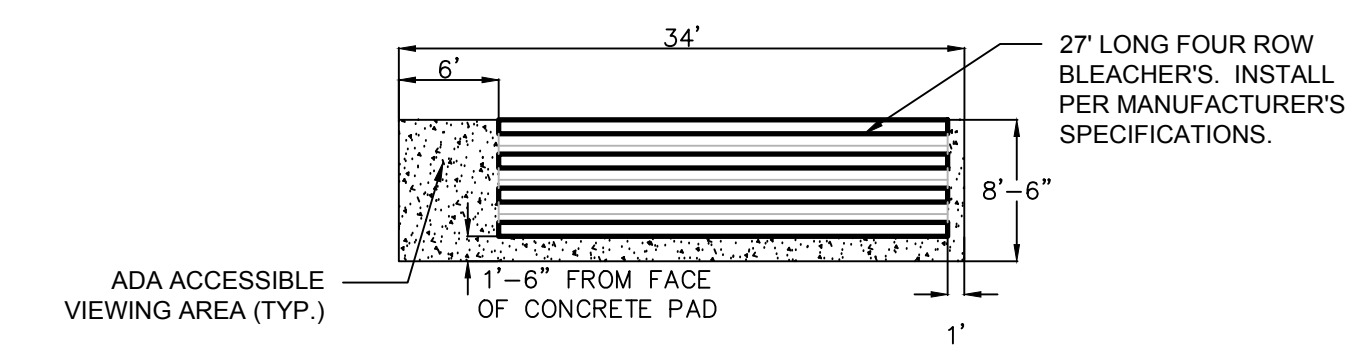

27' FOUR ROW BLEACHER ON CONCRETE PAD

SCALE: NTS

- NOTES:**
1. ORIENTATION OF BLEACHERS ARE TO FACE TOWARDS TENNIS COURTS.
 2. INSTALL BLEACHERS TO CONCRETE PAD PER MANUFACTURER'S SPECIFICATIONS.
 3. SEE PLAN FOR LOCATION OF ADA VIEWING AREA, MAY CHANGE SIDES BASED ON LOCATION OF BLEACHERS.

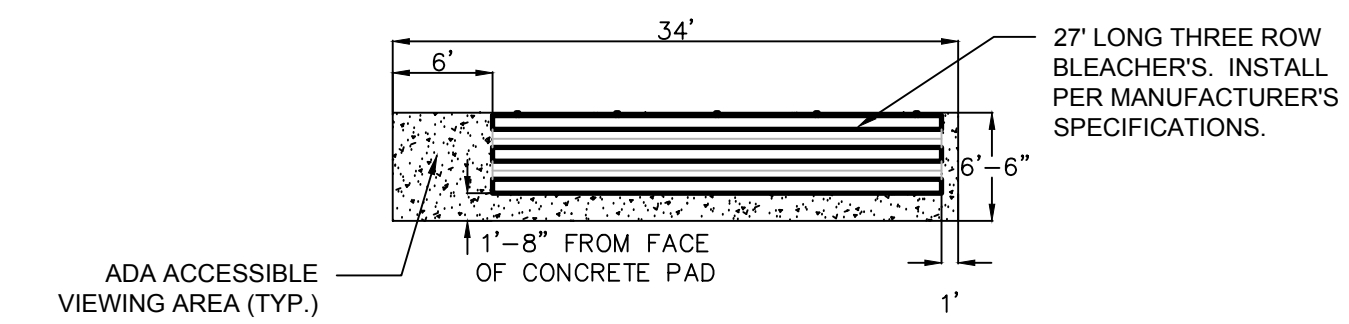

27' THREE ROW BLEACHER ON CONCRETE PAD

SCALE: NTS

- NOTES:**
1. ORIENTATION OF BLEACHERS ARE TO FACE TOWARDS TENNIS COURTS.
 2. INSTALL BLEACHERS TO CONCRETE PAD PER MANUFACTURER'S SPECIFICATIONS.
 3. SEE PLAN FOR LOCATION OF ADA VIEWING AREA, MAY CHANGE SIDES BASED ON LOCATION OF BLEACHERS.

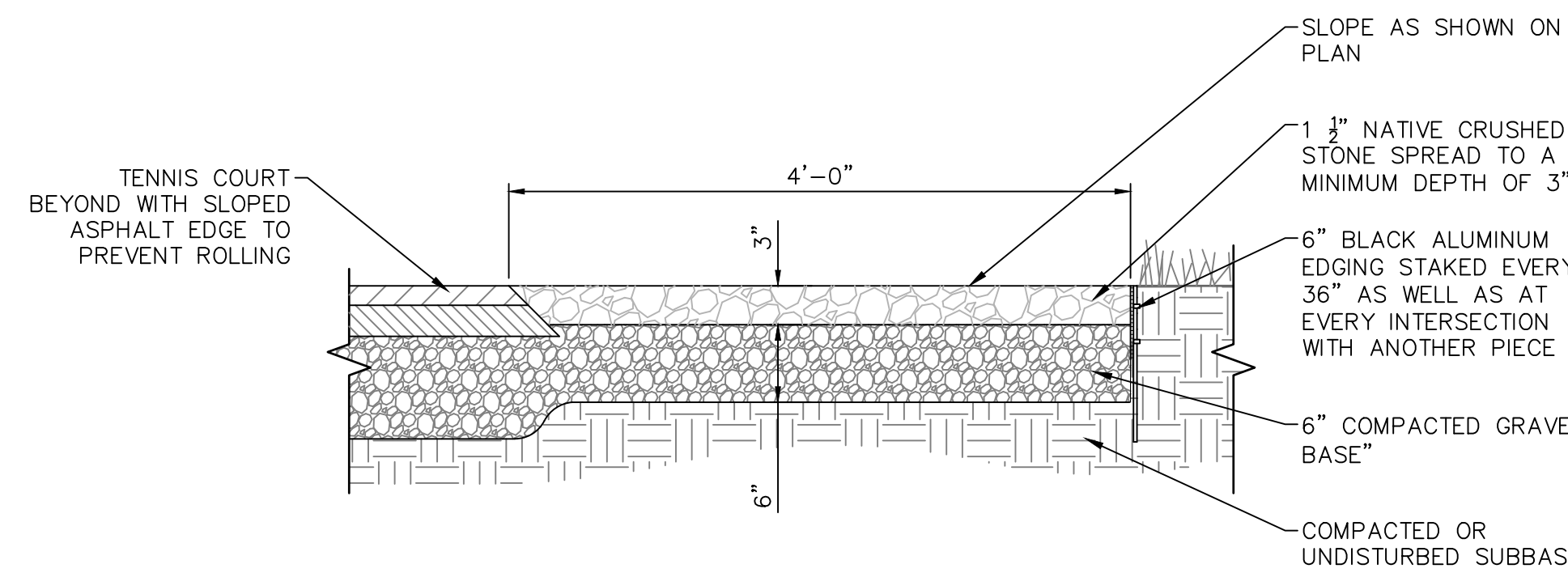

CRUSHED STONE PERIMETER

SCALE: NTS

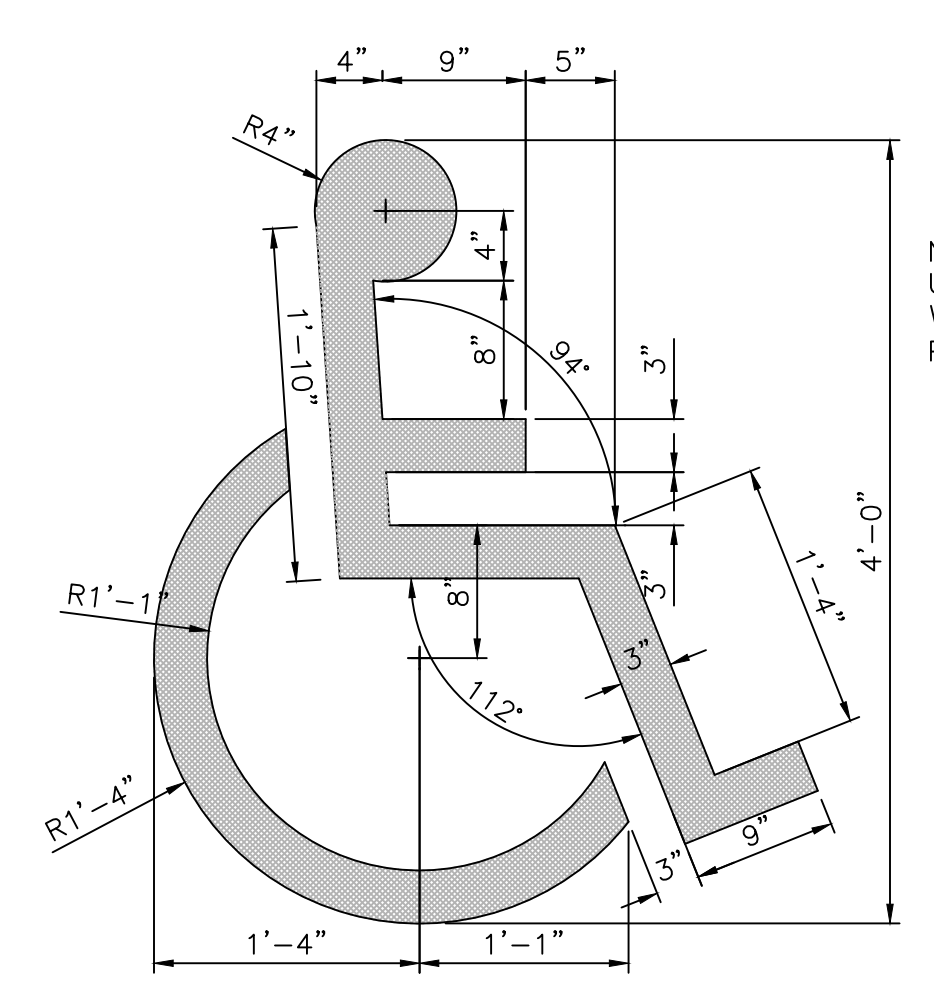

HANDICAP LOGO PAVING MARKER DETAIL

SCALE: NTS

NOTE:
USE TWO COATS OF WHITE EPOXY RESIN PAINT, (TYP.).

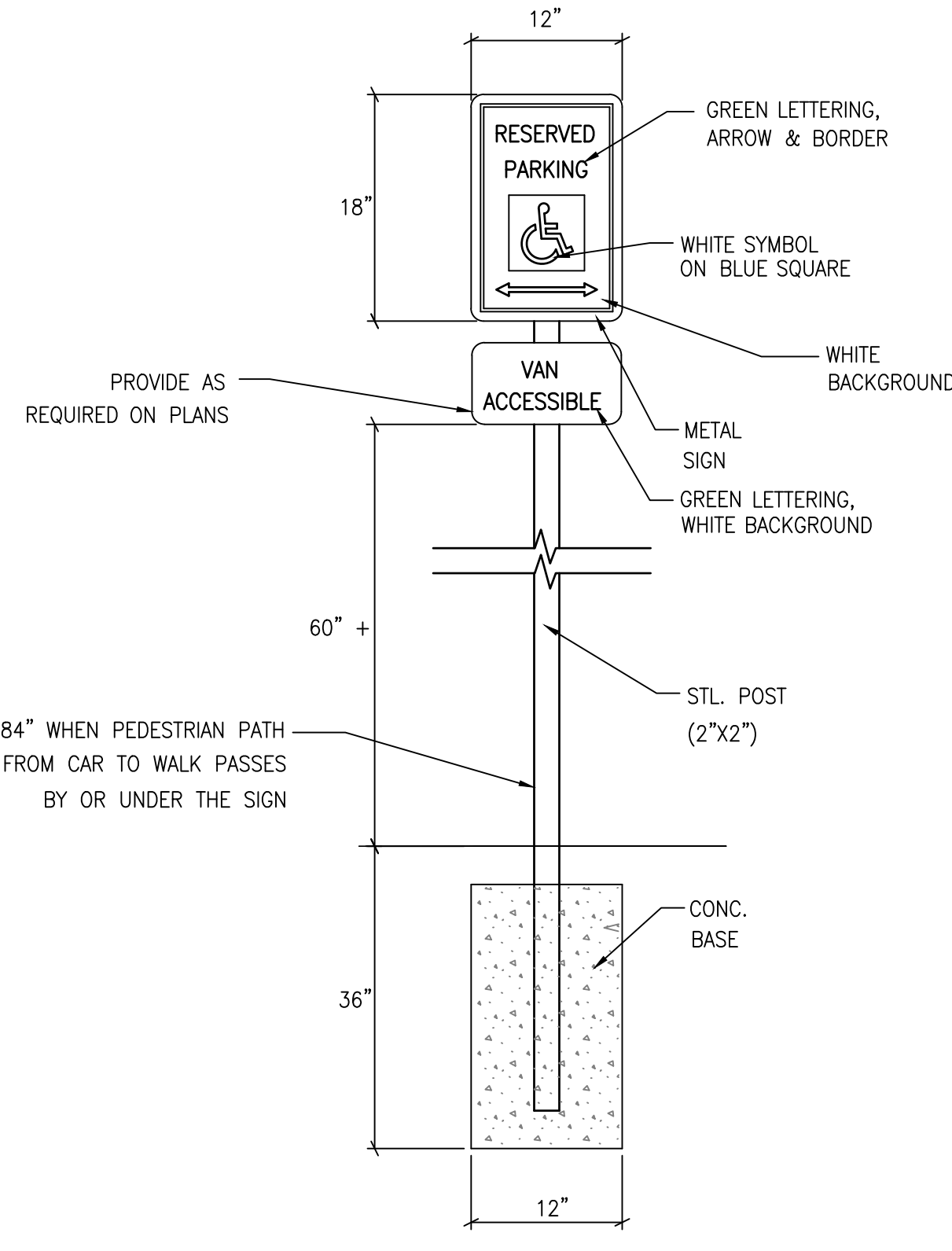

HANDICAP PARKING SIGN DETAIL

SCALE: NTS

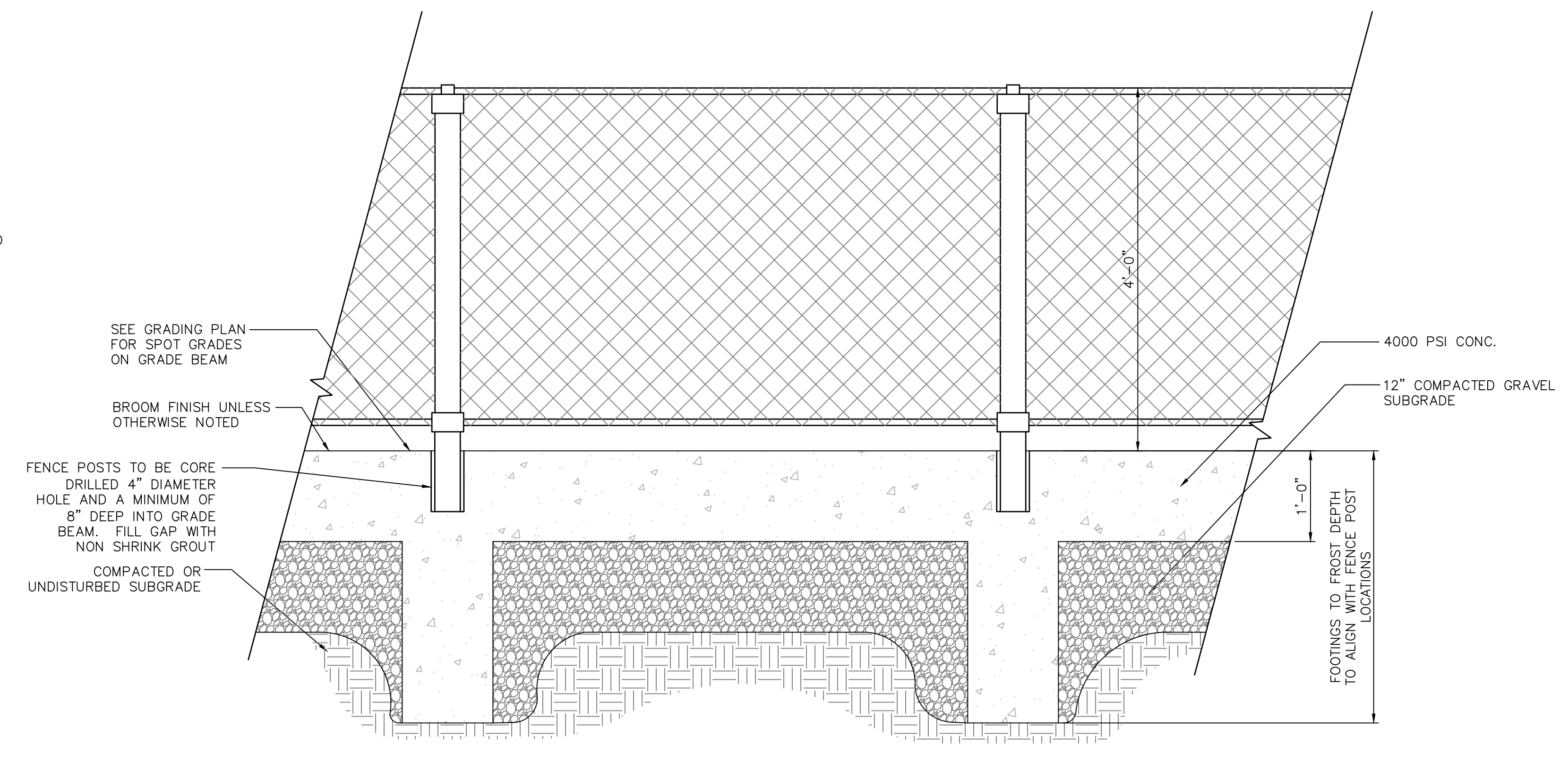

CONCRETE GRADE BEAM

SCALE: NTS

Jan 11, 2023, 2:05pm jwheeler G:\08521\18\2101920\DWG\DN210192001.dwg
LayOut: DN-01



ARCHITECTURE
ENGINEERING
ENVIRONMENTAL
LAND SURVEYING

355 Research Parkway
Middletown, CT 06450
(203) 630-1406
(203) 630-2615 Fax

TENNIS COURT RENOVATION
 PORTSMOUTH HIGH SCHOOL
 50 ANDREW JARVIS DR., PORTSMOUTH, NH 03801

| REVISIONS | Date | Desc. |
|-------------|-----------------------|-------|
| No. | | |
| Surveyed | | |
| Drawn | JW | |
| Reviewed | JW | |
| Scale | | |
| Project No. | 2101920 | |
| Date | 01/03/2023 | |
| CAD File: | | |
| Title | SITE DETAILS 1 | |
| Sheet No. | | |

DN-01

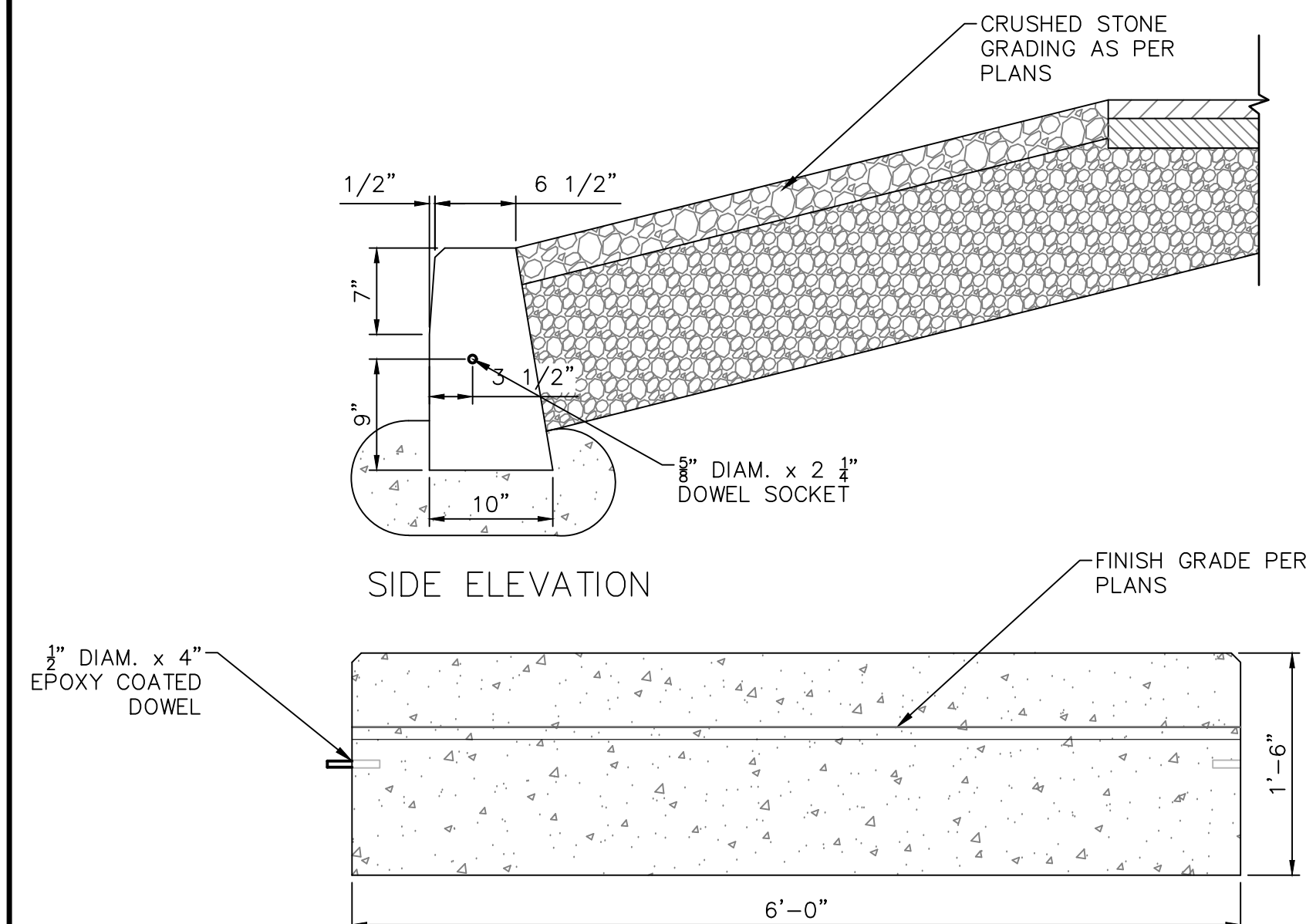

PRECAST CONCRETE CURB
SCALE: NTS

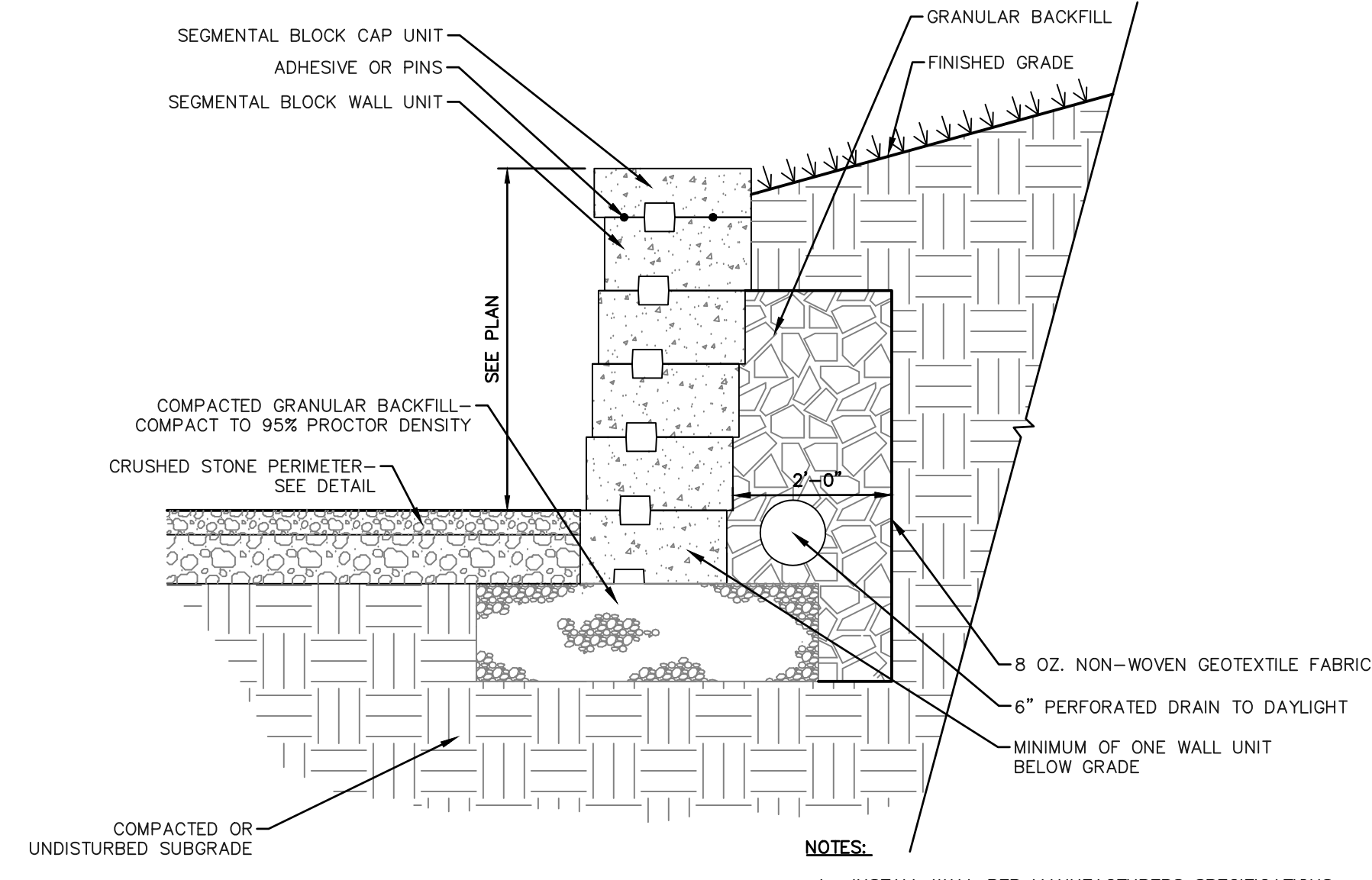

SEGMENTAL BLOCK RETAINING WALL
SCALE: NTS

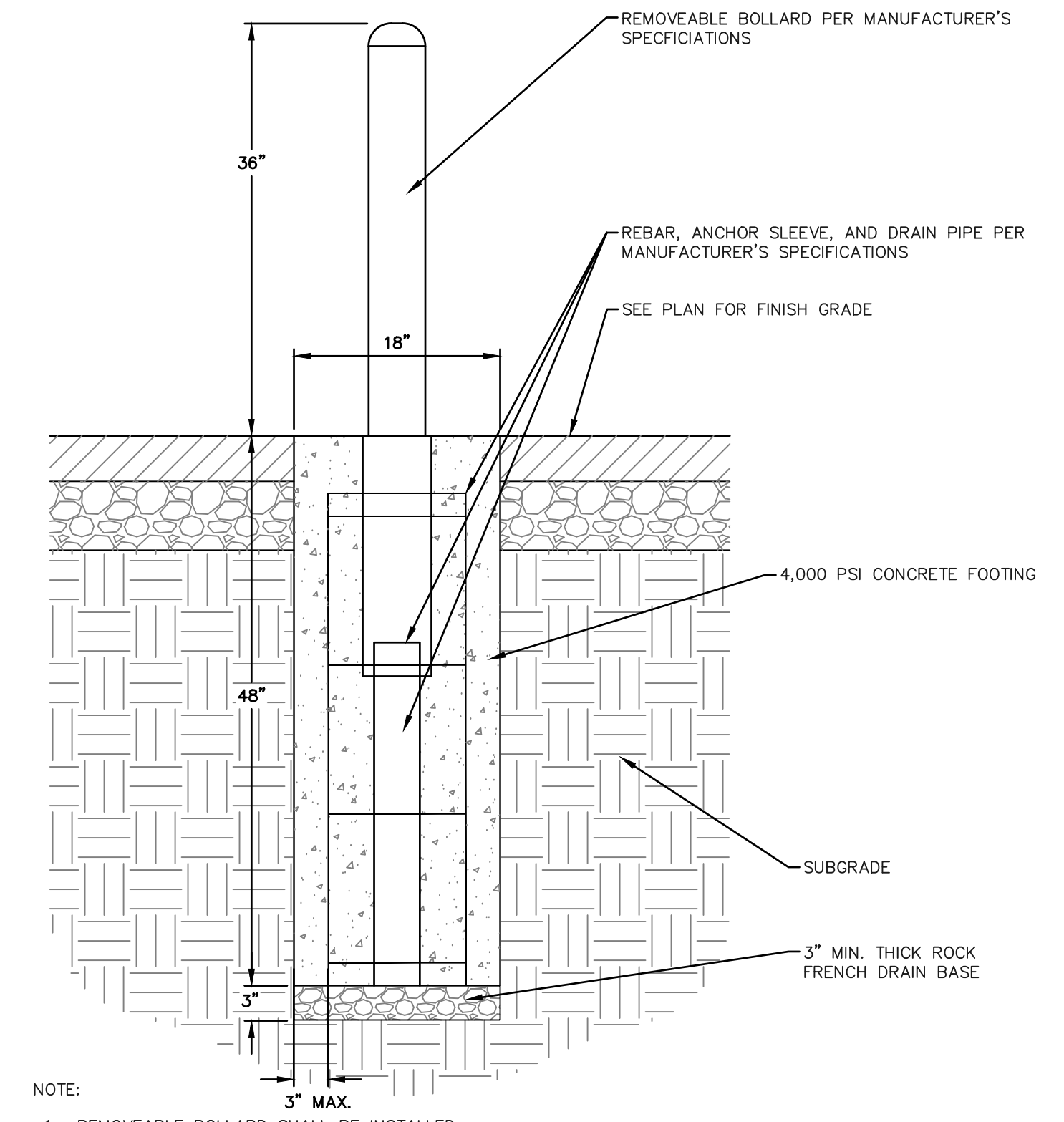

REMOVEABLE BOLLARD DETAIL
SCALE: NTS

- NOTES:
1. ALL DIMENSIONS ARE TO THE OUTSIDE EDGE OF LINES.
2. CENTER SERVICE LINE AND CENTER MARK SHALL BE 2 INCHES WIDE; OTHER LINES SHALL BE BETWEEN 1" AND 2" WIDE, EXCEPT THE BASELINES MAY BE UP TO 4" WIDE.

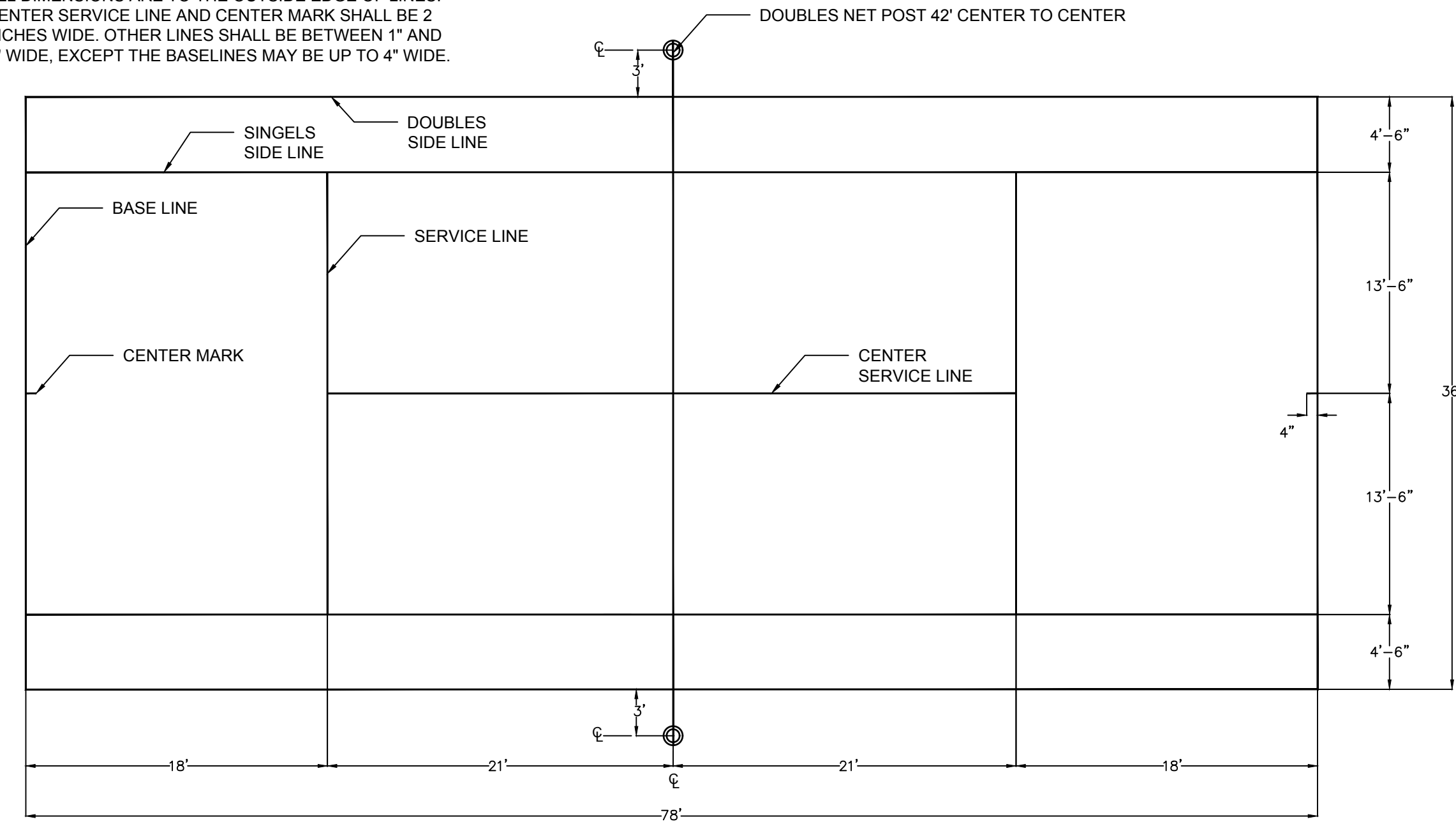

TENNIS COURT STRIPING DETAIL
SCALE: NTS

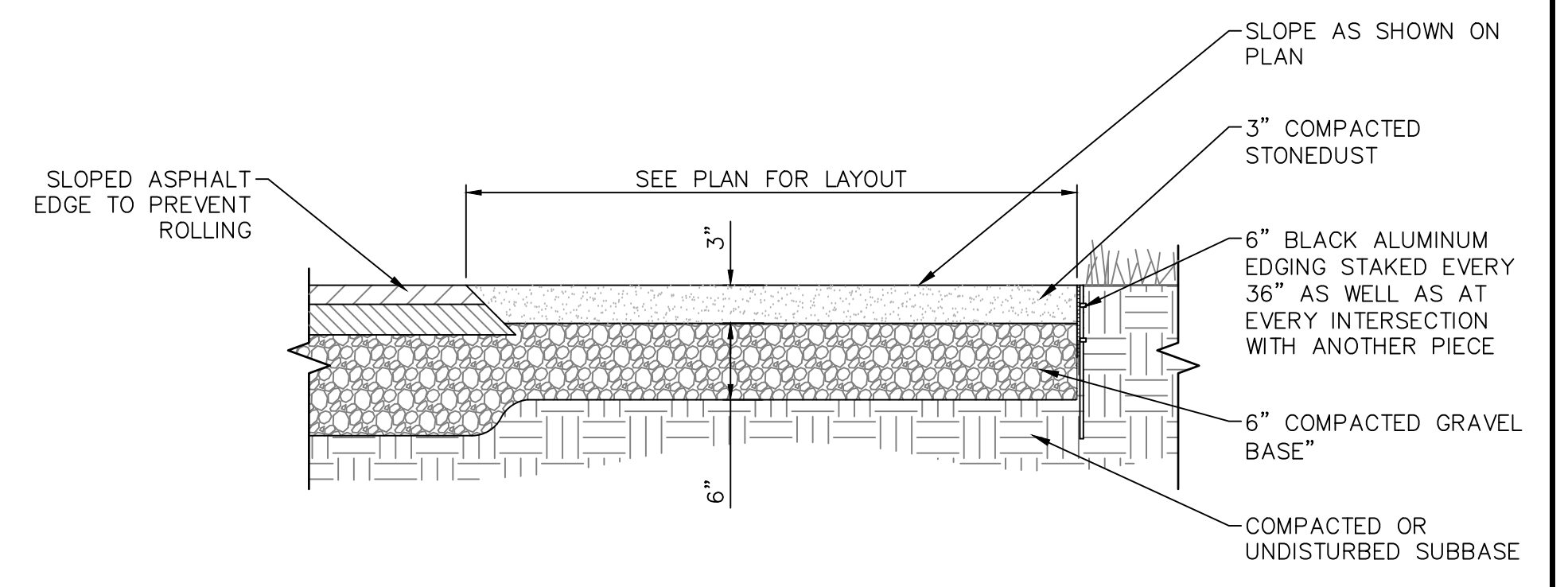

STONEDUST PAVING AT FOUNTAIN
SCALE: NTS

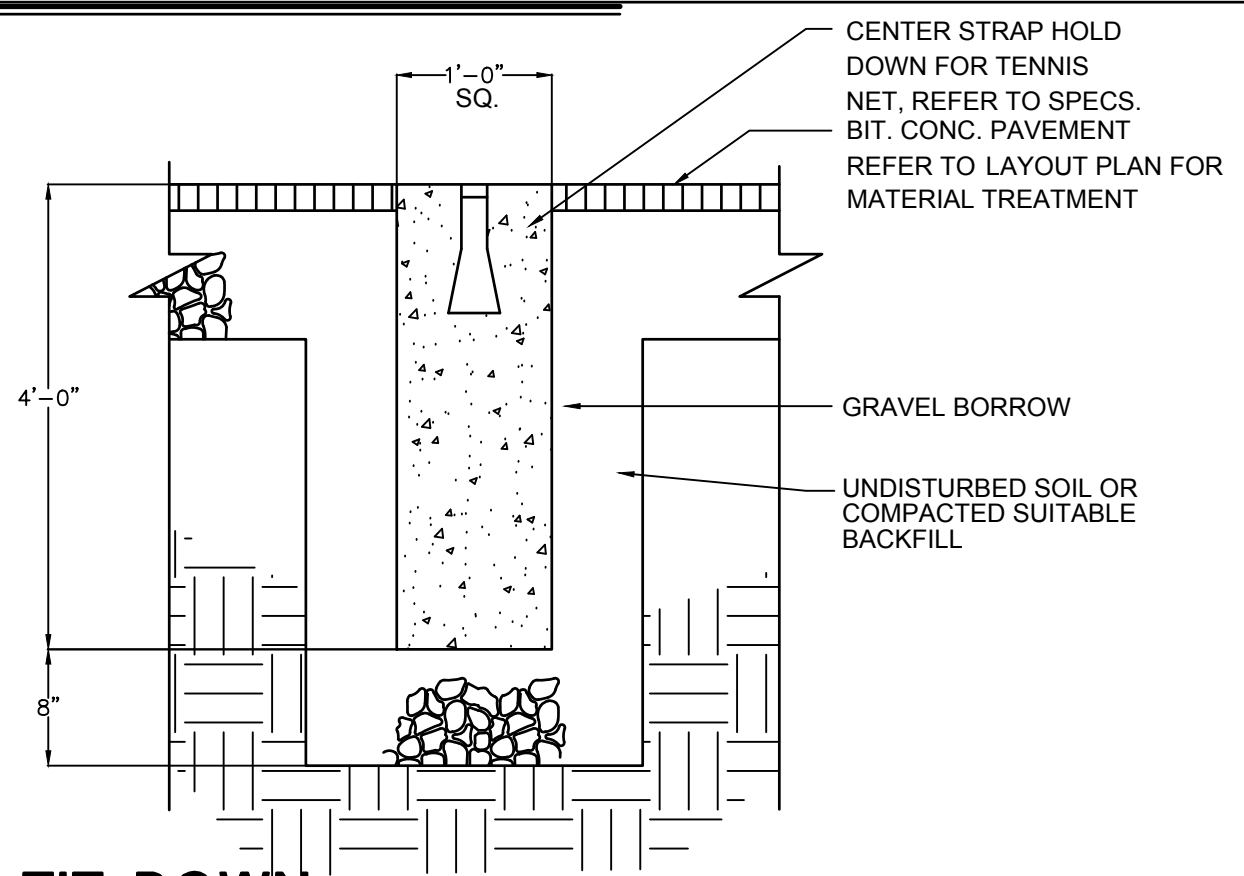

TENNIS NET TIE DOWN
SCALE: NTS

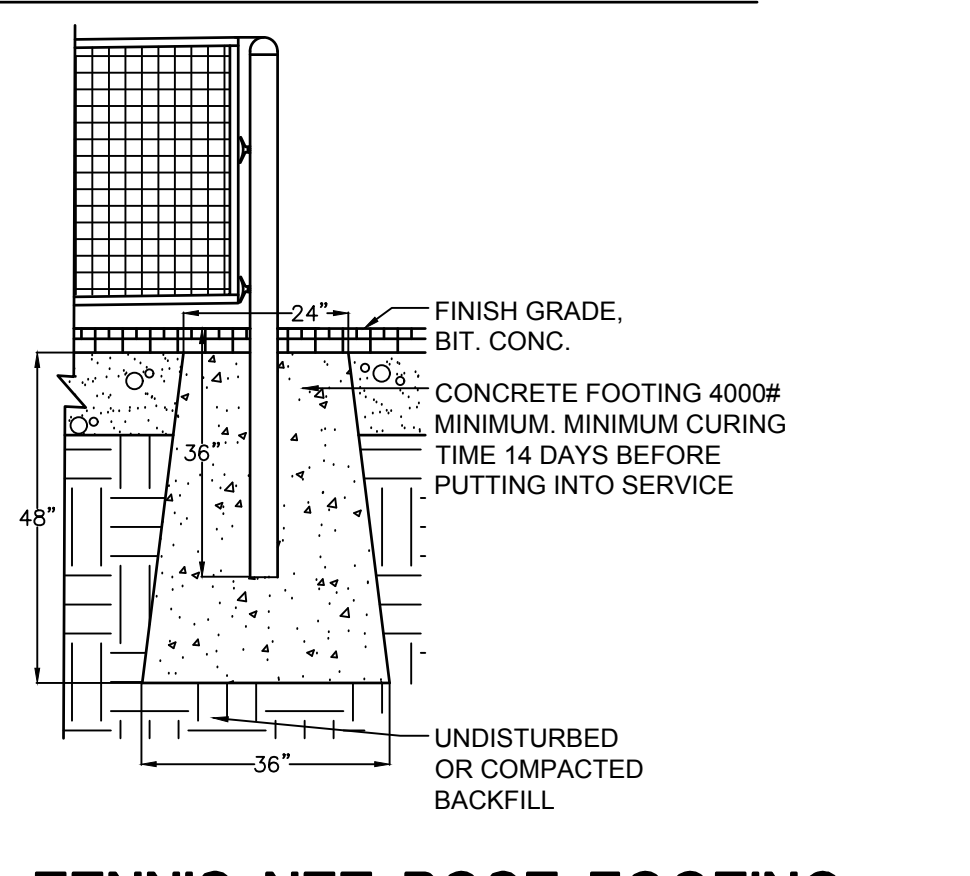

TENNIS NET POST FOOTING
SCALE: NTS

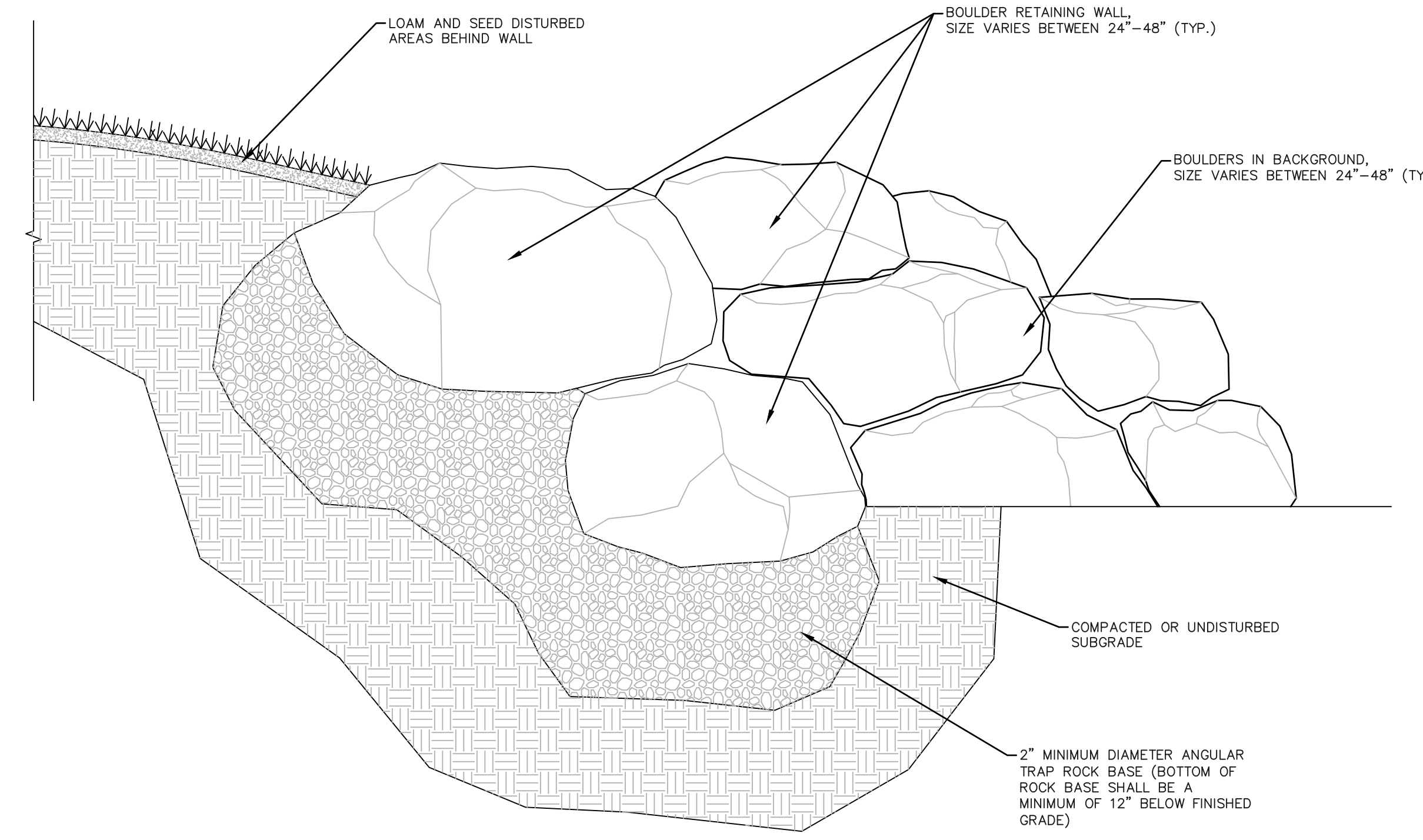

BOULDER WALL DETAIL
SCALE: NTS

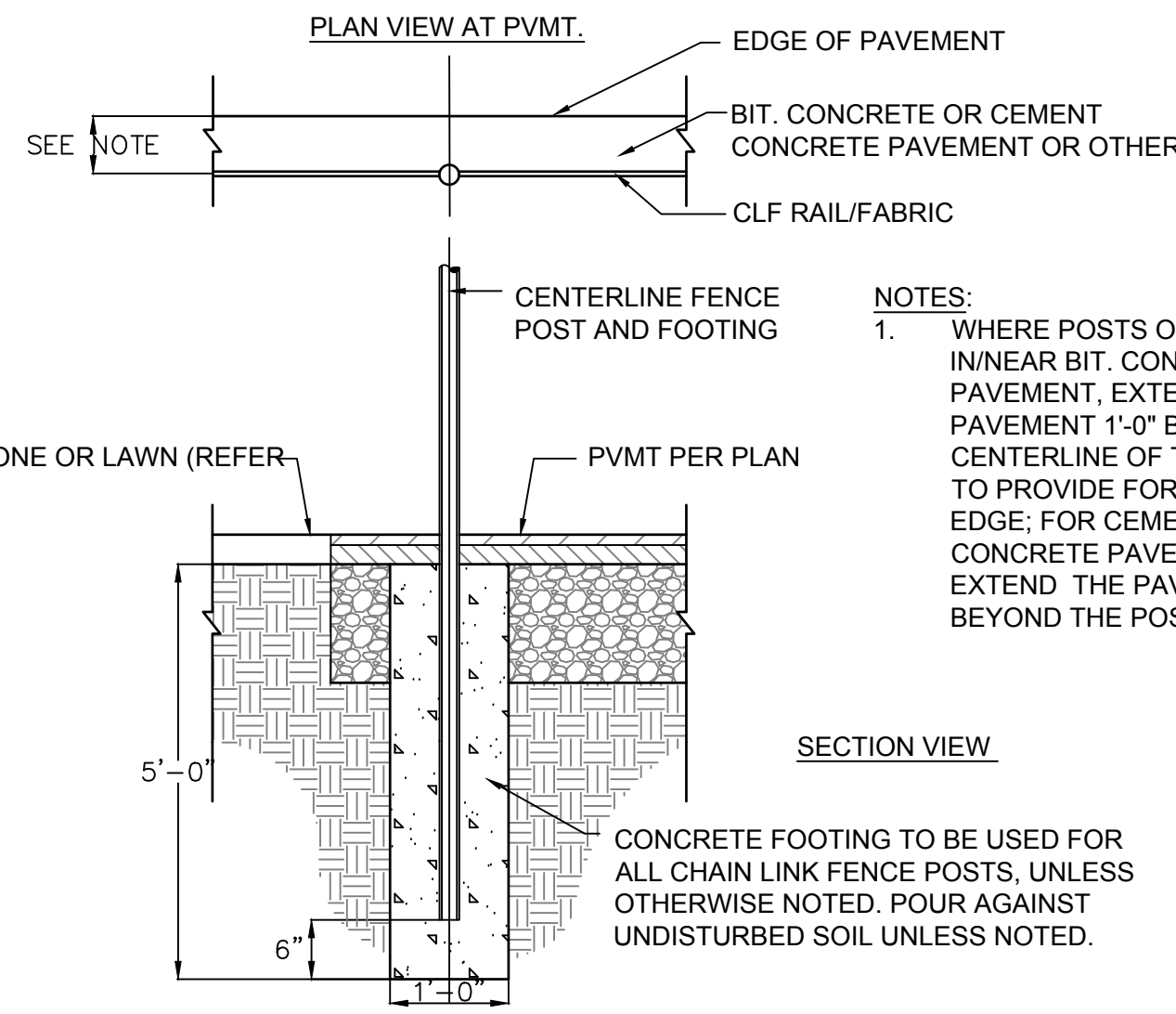

TYPICAL FENCE POST FOOTING

SCALE: NTS

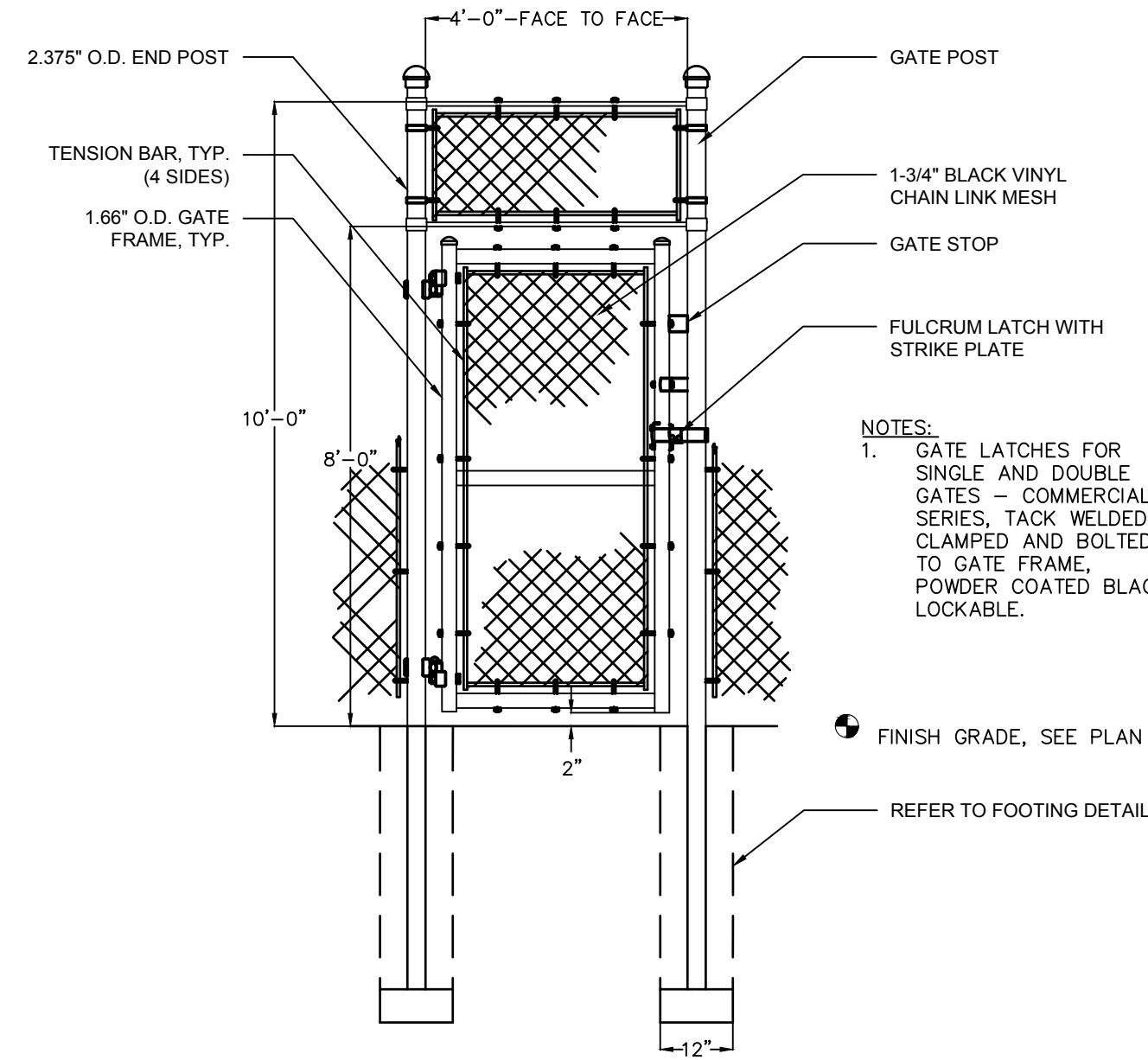

BLACK VINYL CHAIN LINK FENCE SINGLE GATE

SCALE: NTS

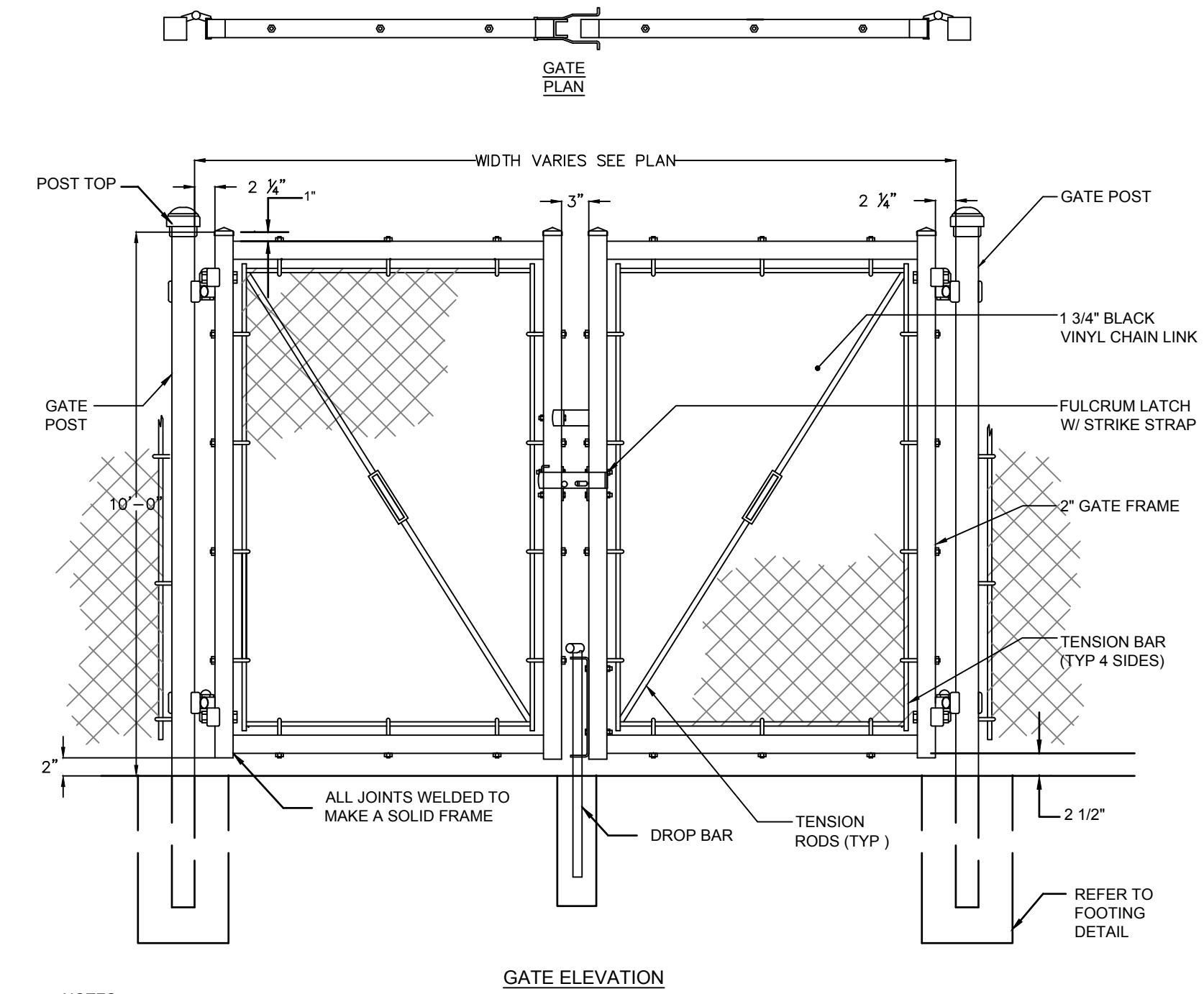

BLACK VINYL CHAIN LINK FENCE DOUBLE SWING GATE

SCALE: NTS

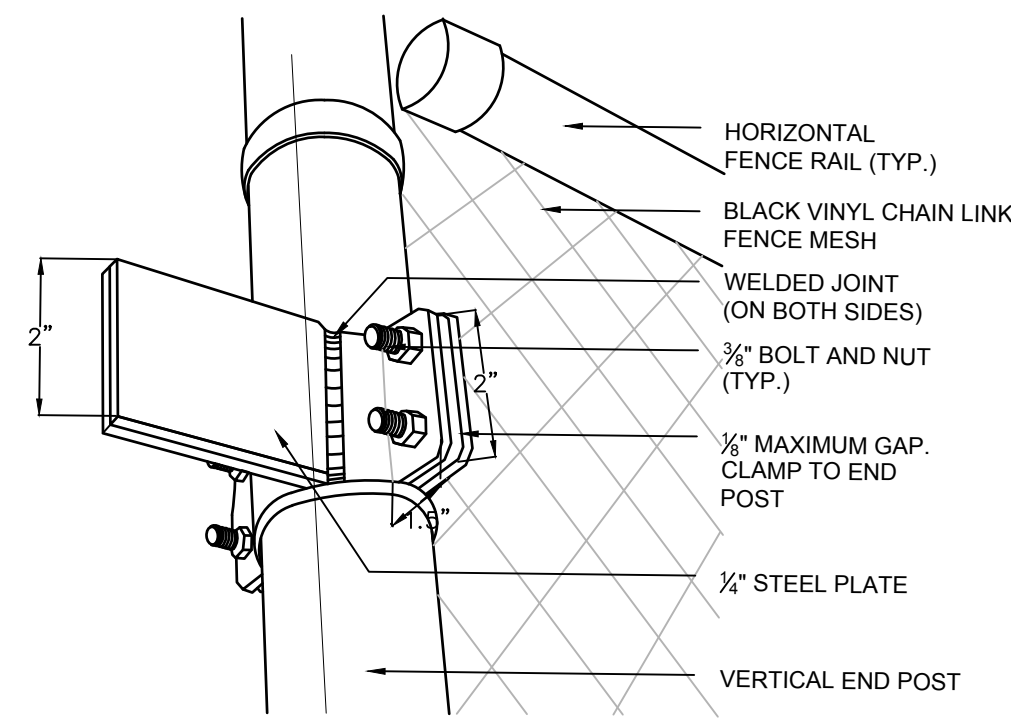

NOTES:
1. PROVIDE GATE STOP AT ALL FENCE GATES.

GATE STOP

SCALE: NTS

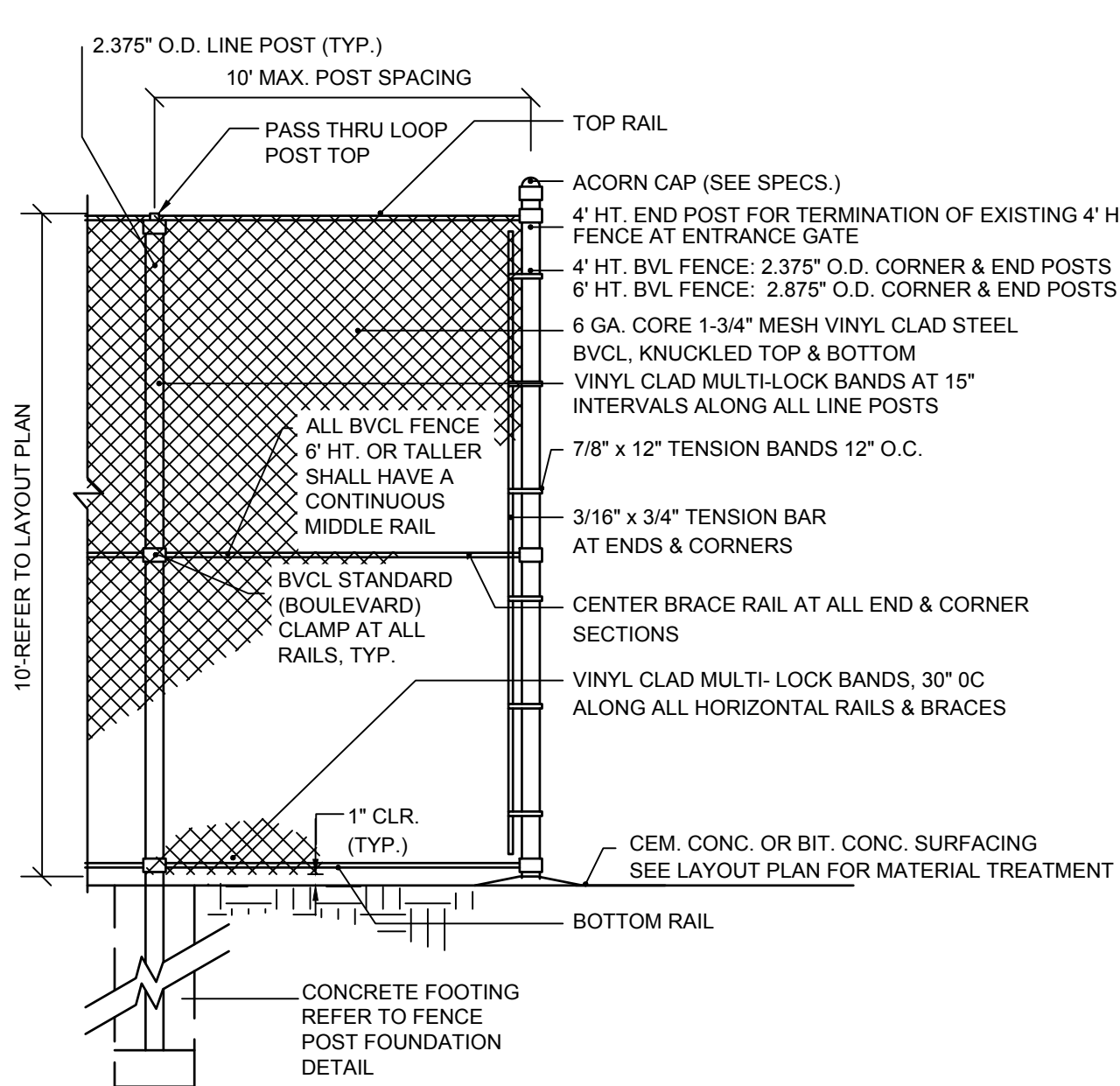

BLACK VINYL CHAIN LINK FENCE - TENNIS COURT

SCALE: NTS

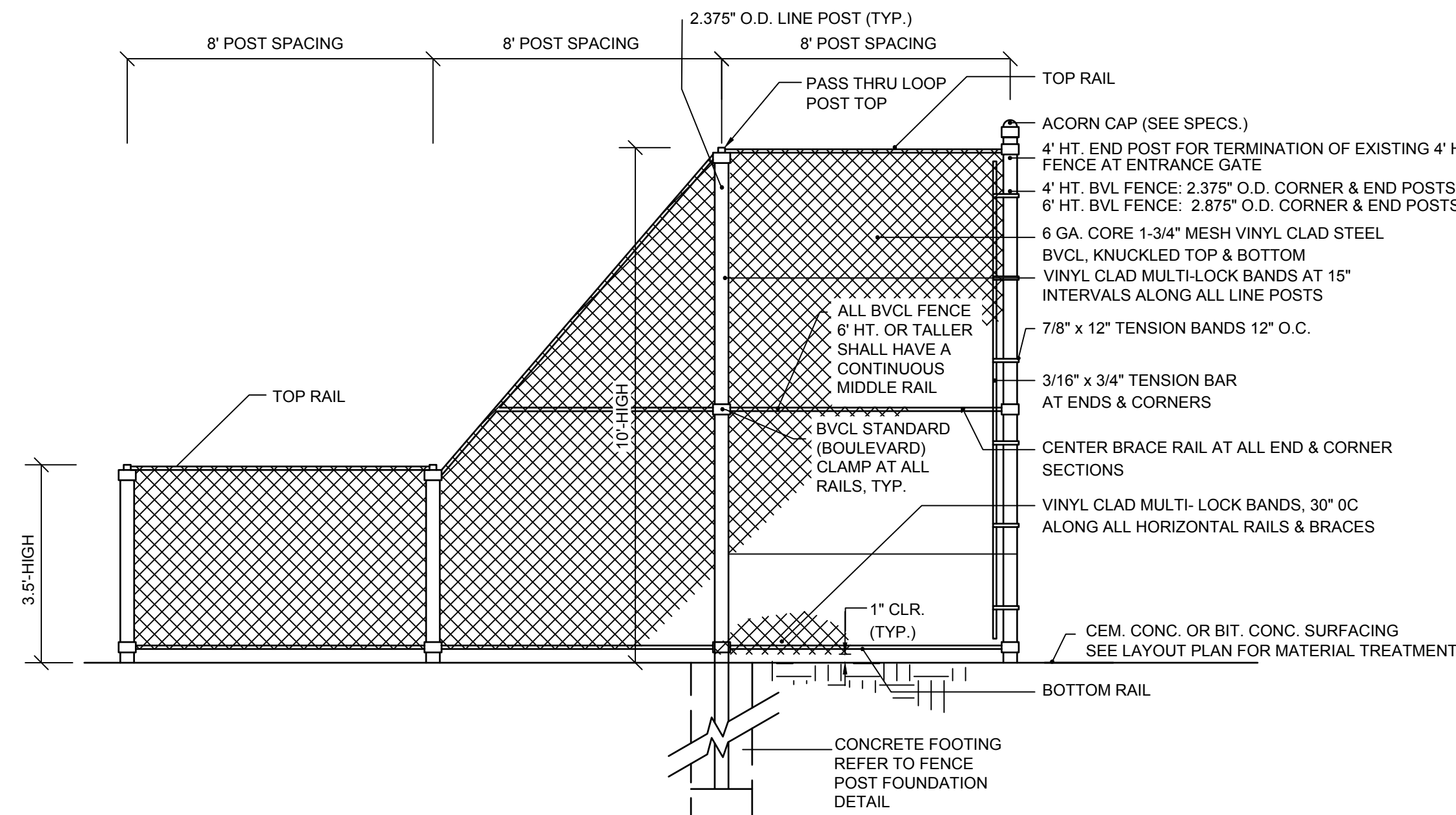

BLACK CHAIN LINK FENCE VARYING HEIGHT DIVIDER

SCALE: NTS