

**REGULAR MEETING
CONSERVATION COMMISSION
1 JUNKINS AVENUE
PORTSMOUTH, NEW HAMPSHIRE
EILEEN DONDERO FOLEY COUNCIL CHAMBERS**

3:30 P.M.

October 11, 2023

AGENDA

I. APPROVAL OF MINUTES

1. September 13, 2023

II. STATE WETLAND BUREAU APPLICATIONS (NEW BUSINESS)

1. Maplewood Avenue Bridge
City of Portsmouth, Owner
Between Assessor Map 123, Lot 10 and Map 123, Lots 1 &9

III. WETLAND CONDITIONAL USE PERMIT APPLICATIONS (NEW BUSINESS)

1. 0 Springbrook Circle
Spring Brook Condominium Association, Owner
Assessor Map 272, Lot 6

IV. WORK SESSIONS

1. 815 Lafayette Road
Prospect North 815, LLC, Owner
Assessor Map 245, Lot 3

V. OTHER BUSINESS

1. Presentation by Dover, NH Open Land Committee (November 15, 2023).

VI. ADJOURNMENT

**Members of the public also have the option to join this meeting over Zoom, a unique meeting ID and password will be provided once you register. To register, click on the link below or copy and paste this into your web browser:*

https://us06web.zoom.us/webinar/register/WN_MEqjcj43Q8uzLWaoYPO1hg

**MINUTES
CONSERVATION COMMISSION
1 JUNKINS AVENUE
PORTSMOUTH, NEW HAMPSHIRE
EILEEN DONDERO FOLEY COUNCIL CHAMBERS**

3:30 P.M.

September 13, 2023

MEMBERS PRESENT: Chair Samantha Collins; Vice Chair Barbara McMillan; Members; Allison Tanner, Lynn Vaccaro, Stewart Sheppard, Adam Fitzpatrick and Alternates; Abigail Gindele and Brian Gibb

MEMBERS ABSENT: Jessica Blasko

ALSO PRESENT: Peter Britz, Environmental Planner/Sustainability Coordinator; Kate Homet, Associate Environmental Planner;

*Recording timestamps denoted in brackets []

The meeting began at 3:30 p.m.

I. APPROVAL OF MINUTES

[5:03] Ms. Gindele asked that the minutes be reviewed as they had incorrect information on some of the votes for an application.

Ms. Tanner made a motion to approve the August 9th, 2023 minutes with the condition to correct information about who voted previously on one of the applications. Vice Chair McMillan seconded the motion. The motion was unanimously approved with Chair Collins abstaining from the vote.

II. WETLAND CONDITIONAL USE PERMIT APPLICATIONS (NEW BUSINESS)

1. 90 F.W. Hartford Drive
Amrishi & Andrea Chicooree, owners
Assessor Map 269, Lot 45

[7:30] Ash Chicooree from 90 FW Hartford Drive came to present this application. Mr. Chicooree went on to describe how he had removed trees from his property without a permit and how he spoke with Ms. Homet about the violation and the necessary restoration plan. He noted how a shed was on the property when he first purchased the home back in 2015, this shed was also within the buffer. His main concerns about the trees were that they were too close to the house along with his neighbor's house and that they were in bad shape. He noted that some of the remaining stumps were from trees that were cut by the previous owner. The commission said they would need to get a delineation done to verify these boundaries rather than using the city wetland map.

[15:16] Ms. Tanner asked whether he was an arborist and that an arborist is needed to determine whether a tree was cut. She said he should work with a wetland scientist to determine where the wetlands are and come up with a restoration plan.

Chair Collins noted that the first step towards restoration will have include getting a delineation done so he knows where the boundary is on his property.

Ms. Homet said he needs a wetland conditional use permit for the shed even if it is after the fact.

Mr. Chicooree brought up how there are about 4 or 5 additional trees that are dead or dying that he may want to take down as well.

Ms. Gindele explained that dead trees serve an important ecological function and should not be cut in the buffer.

Mr. Chicooree responded that he should be able to use his property reasonably and he was not willing to leave trees that pose a hazard.

Chair Collins said that the Commission's job is to provide that balance of the ecological approach.

[27:47] Ms. Tanner made a motion to postpone this application until a wetland delineation and restoration plan have been completed. Ms. Gindele seconded the motion.

A discussion continued about the order of the delineation and restoration plan and when those responses would be needed by.

Chair Collins asked for new plantings that are similar to what was removed, acknowledging that the function of a full-grown tree would have to be considered within the restoration plan.

Ms. Gindele said the shed should be included in the application in the after the fact permit.

Mr. Chicooree said he would consider the location for the shed in the new application.

[34:05] The Commission voted unanimously to postpone the application.

2. 80 F. W. Hartford Drive
Julian Frey & Ana Barndollar, owners
Assessor Map 269, Lot 46

[35:00] Julian Frey, the property owner, came to present this application. Similar to his neighbor, Mr. Chicooree, he described the removal of trees without a wetland conditional use permit. He mentioned that he had asked the homeowners association to clear five trees on his property and received approval. His reasoning for removing the five trees was that a solar installer recommended the trees to be removed for better solar output in a future roof array on the property. He has come up with a plan for how to restore the buffer where he has removed the trees and asked the Commission for help in best methods for restoring the site. He also was looking for guidance from them on whether he could remove the stumps and add in a rain garden.

[37:19] Ms. Tanner noted how she liked that he had referenced an ANSE arborist to complete the restoration plan.

[38:05] Ms. Vaccaro mentioned that with large stumps, the applicant may still have a hard time planting near where old roots might be in the ground.

Mr. Frey said he thought it would be better to remove the stumps, but he would look to a subject matter expert to help with that.

[39:28] Vice Chair McMillan made a motion to postpone this application to the October meeting with the stipulations that the applicant will need to have a new delineation done and a thorough restoration plan provided. Ms. Tanner seconded the motion. The motion passed with unanimous approval.

3. 810 McGee Drive
Eric & Amanda Beidleman, owners
Assessor Map 219, Lot 45-5

[40:46] Lynette Rogers came to present this application as a representation of the homeowner. Ms. Rodgers was hired as the contractor to replace the deck and add a new stair to the rear and remove the existing stairs on the side. She noted that the current footings are not to code so they will be replacing them. The new deck will have fewer footings and the deck will have a bigger frame.

[41:48] Chair Collins asked the applicant what the plans were for material underneath the deck.

Ms. Rodgers said she is just replacing the footings, with no plans currently to place any material underneath. After talking with the homeowner after the site visit, the homeowners would be open to placing gravel underneath the new deck to help with infiltration of stormwater.

[42:46] Ms. Tanner noted that they also would be recommending that the applicant place wetland

boundary markers, probably near the fence towards the back of the yard. They would be permanent placards to denote areas of sensitive environmental habitats.

Ms. Tanner also recommended that the applicant used crushed stone under the deck, not gravel.

Ms. Rodgers mentioned that she had recommended crushed stone as well to the homeowners and they were amenable to that.

[44:04] Ms. Tanner made a motion to recommend approval of the application with the following stipulations:

1. Crushed stone be placed underneath the deck area.
2. Wetland boundary markers are placed near or along the fence in the back of the property by the pond.

Mr. Sheppard seconded the motion.

[44:28] Vice Chair McMillan asked that Ms. Rodgers talk with the property owners about only using mounted lighting that faces downwards and will not disturb the wetland resource and nearby habitats.

[46:24] Mr. Fitzpatrick asked if there would be any gaps between the boards used for the decking as it would be important for infiltration down to the crushed stone below.

Ms. Rodgers responded that they would be using fasteners to maintain a specific spacing between all decking materials to ensure that.

[47:06] The motion passed unanimously.

4. 390 F. W. Hartford Drive
Daniel Sigalovsky & Sarah Cook, owners
Assessor Map 249, Lot 25

[48:06] Sarah Cook, the property owner, came to present this application. She gave a brief overview of her plans for replacing her rotting deck with a patio and made note of how she was new to the Woodlands neighborhood and is learning about the wetland restrictions. She is proposing a stone drip edge for infiltration, a rain garden in the location where the sump pump currently outlets, and the installation of rain gutters on the home.

[50:46] Ms. Tanner noted her appreciation for the hand drawn plan and the color that it included for the plantings, saying that it helped visualize what she was proposing.

Vice Chair McMillan voiced her appreciation for the rain garden but noted her concern for how close it would be to the home.

Ms. Cook mentioned that there was already a water feature with river rocks in that area, noting

that it is already wet but would appreciate any advice as the sump pump currently outlets in this location.

A discussion continued about the exact location of the rain garden and how the sump pump and proposed gutters would outlet into it at an appropriate distance away from the home.

[53:18] Chair Collins said that they would like to see getting water away from the home and foundation being prioritized. This would help to prevent further rot.

Vice Chair McMillan recommended placing the downspouts, sump pumps and rain garden at least ten feet away from the home to avoid issues.

[54:30] Ms. Tanner pointed the applicant to the City website for information on the construction of rain gardens.

Ms. Gindele noted that rounding out the corners of the proposed patio would help the landscaping look more organic and natural if the applicant did not want very sharp corners.

[57:48] Mr. Fitzpatrick asked for clarification on what the proposed work was vs. what plantings and garden beds were already there.

Chair Collins asked if there was any heavy machinery being brought in for this work.

Ms. Cook said they might be using a compactor but that they would be doing a lot of the repairs themselves.

[59:14] Vice Chair McMillan mentioned that they usually ask for maintenance plans to be submitted for porous pavers and rain gardens.

[1:01:15] Ms. Tanner made a motion to recommend approval of this application with the following stipulations:

1. Add a cross section of the pervious pavers.
1. Submit a maintenance plan for the pervious pavers and the rain garden.
2. Applicant will install wetland boundary markers to denote sensitive wetland area.

Ms. Gindele seconded the motion. The motion passed unanimously.

III. OTHER BUSINESS

1. Paul's Path- Trail Clearing Project (final vote)

[1:04:08] Ian Cook came before the Commission for recommendation of his project. He gave a brief overview of the project with a discussion of the project ensuing and questions from commissioners who were not able to make the site walk.

[1:09:55] Mr. Sheppard made a motion to approve of the trail clearing project. Ms. Tanner

seconded the motion. Vice Chair McMillan recused herself from the vote. The motion passed unanimously 7-0.

2. Non-Public Meeting Date

[1:10:42] Ms. Homet mentioned that the Commission had wanted to plan a non-public date to go over potential conservation land purchases. A date has been set aside for this meeting in Conference Room A on October 18th, 2023 at 3:30 p.m.

She mentioned that staff were also considering bringing in someone from Dover's Open Lands Committee to give a brief presentation to the group on how they conserve land and the criteria that they use for finding property.

Ms. Vaccaro asked if there were any land trusts involved with this process for Portsmouth and if they should also be invited to a meeting.

A discussion started on the conservation of land process and perhaps having a presentation given to the Commission before moving forward again.

[1:19:25] Ms. Vaccaro brought up a discussion item about the Coastal Conservation Commission which hosts monthly roundtable and how they were planning for an upcoming conversation on flood disclosure information which this group might be interested in attending. This could potentially create a quorum issue.

[1:21:59] Additionally, she mentioned two other engagement opportunities. One is through Pollinator Pathways, a NH group that would like to pitch the Commission to be a partner or liaison for their events. The last discussion item was an offer from the UNH Extension to perform a green lawncare clinic in the City as part of a pilot program.

IV. ADJOURNMENT

Memo



TO: Conservation Commission Members
FROM: Kate Homet, Associate Environmental Planner
CC: Peter Britz, Planning & Sustainability Director
DATE: October 6, 2023
SUBJ: October 11, 2023 Conservation Commission Meeting

**0 Springbrook Circle
Springbrook Condominium Association
LU-23-157**

This application is requesting a Wetland Conditional Use Permit for the installation of a concrete sidewalk within the City's 100-ft wetland buffer. This sidewalk will connect an existing parking lot to an existing walkway. It is an additional of approximately 870 s.f. of impervious surface to the buffer, which consists of a 5' wide sidewalk that will be approximately 174' long. The applicant is proposing to install new plantings within the buffer to offset the impacts of the proposed impervious surface and will be installing a culvert where the sidewalk will cross over an existing drainage ditch.

1. The land is reasonably suited to the use activity or alteration.

The applicant is proposing to increase the impervious surface within the buffer. The existing surface is mowed lawn which connects to existing sidewalks. This area is already manicured and disturbed.

2. There is no alternative location outside the wetland buffer that is feasible and reasonable for the proposed use, activity or alteration.

The applicant is proposing a sidewalk to remove the impediment of residents walking from the overflow parking lot to their homes via the street. While there are alternative locations for the sidewalk, the applicant has selected the shortest route for the proposed sidewalk.

3. There will be no adverse impact on the wetland functional values of the site or surrounding properties.

Any increase in impervious surface within the buffer will have an adverse impact on wetland health. The applicant is proposing to install more plantings near the building. The applicant should only plant native buffer plantings. In addition to plants by the building, they should also consider increasing the native buffer plantings along the edge of the pond.

4. Alteration of the natural vegetative state or managed woodland will occur only to the extent necessary to achieve construction goals.

The natural vegetative state will not be altered aside from the change of mowed grass to concrete sidewalk.

5. The proposal is the alternative with the least adverse impact to areas and environments under the jurisdiction of this section.

Applicant is proposing the location of the new sidewalk be a balance between staying far from the pond but not so close to the building that it could encroach upon residents' privacy. In doing so, they have proposed a location that appears to stay outside of the 25' buffer. Additional native buffer plantings and downcast lighting will help to minimize the impacts to the pond environment.

6. Any area within the vegetated buffer strip will be returned to a natural state to the extent feasible.

The proposed sidewalk appears to stay out of the 25' buffer. We recommend that the applicant enhance this area through additional native buffer plantings and potential phragmites/invasive species control.

Recommendation: Staff recommend approval of this application with the following stipulations.

1. In accordance with Section 10.1018.40 of the Zoning Ordinance, applicant shall install permanent wetland boundary markers during project construction. These can be purchased through the City of Portsmouth Planning and Sustainability Department.
2. In addition to the planned plantings for Building #5, the applicant shall plant additional native buffer species along the pond to increase the vegetation within the 25' vegetative buffer.
3. Any plans for lighting of the proposed sidewalk shall include downcast lighting to limit the impact to the wetland ecosystem.
4. The applicant should make every effort to eliminate salt and other chemicals from their winter maintenance of the sidewalks near the pond.

Repair of the Maplewood Avenue Bridge Over North Mill Pond, Portsmouth, NH

New Hampshire Department of
Environmental Services

Wetlands Bureau Permit Application

Hoyle, Tanner Project Number: 20.905110



Prepared By:



August 2023



August X, 2023

D.E.S. Wetlands Bureau
P.O. Box 95
Concord, NH 03302-0095

Re: Wetlands Permit Application
Repair of the Maplewood Avenue Bridge
Over North Mill Pond, Portsmouth, NH
Hoyle, Tanner Project No. 20.905110

Dear Sir/Madam:

The Maplewood Avenue Bridge (NH DOT Bridge No. 231/103) is a single-span stone arch bridge that was initially constructed in 1896, has a total span length of 25' and carries two lanes of traffic on a 32' wide paved roadway with sidewalks on each side. The City of Portsmouth (City) is proposing to repair the grouted corrugated metal plate arch (CMPA) liner that was installed in 1976 as part of a previous rehabilitation project. The Maplewood Avenue bridge is a heavily trafficked vital piece of infrastructure within the City as it acts as gateway to the downtown area. The bridge is currently on the State's 'Red List' of poor condition bridges due to its condition rating of 3, or 'Serious'. Closure of the bridge would be detrimental to the City and the stakeholders in the area.

Due to the deteriorated condition of the CMPA, compromised stone arch, and limited funding sources, the City is proposing a repair project to stabilize the bridge for the protection of the traveling public. The repair will consist of installation of a spray-applied geopolymer liner to the inside surface of the metal culvert liner that will restore structural integrity. In addition, sections of the historic retaining wall supporting Maplewood Avenue will be reconstructed and stabilized with reuse of the existing stone. Supplemental riprap will be re-installed along areas of the north side inlet to protect the restored retaining walls from future tidal impacts. Drainage system improvements, roadway reconstruction and guardrail support slab replacement will mitigate the existing roadway settlement, ponding and sidewalk rotation. The service life of the repaired structure will be approximately ten to fifteen years, at which time a complete replacement would need to occur. Traffic will be managed by a combination of alternating 1-way traffic through the site and portions of complete shutdown with a detour.

There will be 20,227 sq. ft. of temporary impacts and 537 sq. ft. of permanent impacts as a result of this project. All areas of temporary disturbance will be stabilized and revegetated as needed at the completion of construction. A filing fee of \$8,305.60 is included with the package. All abutters to this project have been notified by certified mail. The current schedule is to construct this project in the spring of 2024 with completion in late summer/early fall 2024.

If you require any additional information, please feel free to contact me at your convenience.

Very truly yours,
HOYLE, TANNER & ASSOCIATES, INC.

Kimberly R. Peace
Senior Environmental Coordinator

TABLE OF CONTENTS

- PROJECT LOCATION MAP – USGS 1:24,000 COLOR TOPO MAP
- NHDES WETLANDS BUREAU PERMIT APPLICATION
- ATTACHMENT A MINOR AND MAJOR PROJECTS
- AVOIDANCE AND MINIMIZATION CHECKLIST
- WETLANDS RULE WAIVER REQUEST
- SUPPLEMENTAL NARRATIVE
 - WORK/CONSTRUCTION SEQUENCE
 - RELATIVE TIMING
 - CONSERVATION COMMISSION COORDINATION
 - FEDERAL AGENCY COORDINATION
 - SLOPE STABILIZATION & RIPRAP INSTALLATION
 - MITIGATION
- RIPRAP CALCULATIONS
- PREAPPLICATION AND MITIGATION MEETING NOTES
- STREAM CROSSING REQUIREMENTS NARRATIVE
- SUPPLEMENTAL REPORT ADDRESSING ENV-WT 903.05(f), 904.07(d) AND 603.05 INCLUDING HYDRAULIC ANALYSIS AND WATERSHED MAP PREPARED BY HEADWATERS CONSULTING, LLC
- US ARMY CORPS OF ENGINEERS NEW HAMPSHIRE PROGRAMMATIC GENERAL PERMIT (PGP) APPENDIX B CHECKLIST
 - EXPLANATIONS FOR CHECKLIST ANSWERS
 - NATURAL HERITAGE BUREAU (NHB) REVIEW & NHFG COORDINATION EMAIL
 - US FISH AND WILDLIFE (USF&W) IPAC RESULTS & DOCUMENTATION
 - RESPONSES FROM NHDHR FOR REQUEST FOR PROJECT REVIEW
- WETLAND DELINEATION REPORT, FUNCTIONAL ASSESSMENT & SITE PHOTOS
- TAX MAP
- ABUTTERS LIST
- SAMPLE NOTICE TO ABUTTERS
- DOCUMENTATION OF APPLICANT’S LEGAL INTEREST- EASEMENT
- NHDOT SPECIFICATIONS SECTION 583 RIPRAP
- PROJECT PLANS
- EXISTING CONDITIONS PLANS

Document Path: K:\9051103-GIS\Graphics\USGS Map.mxd

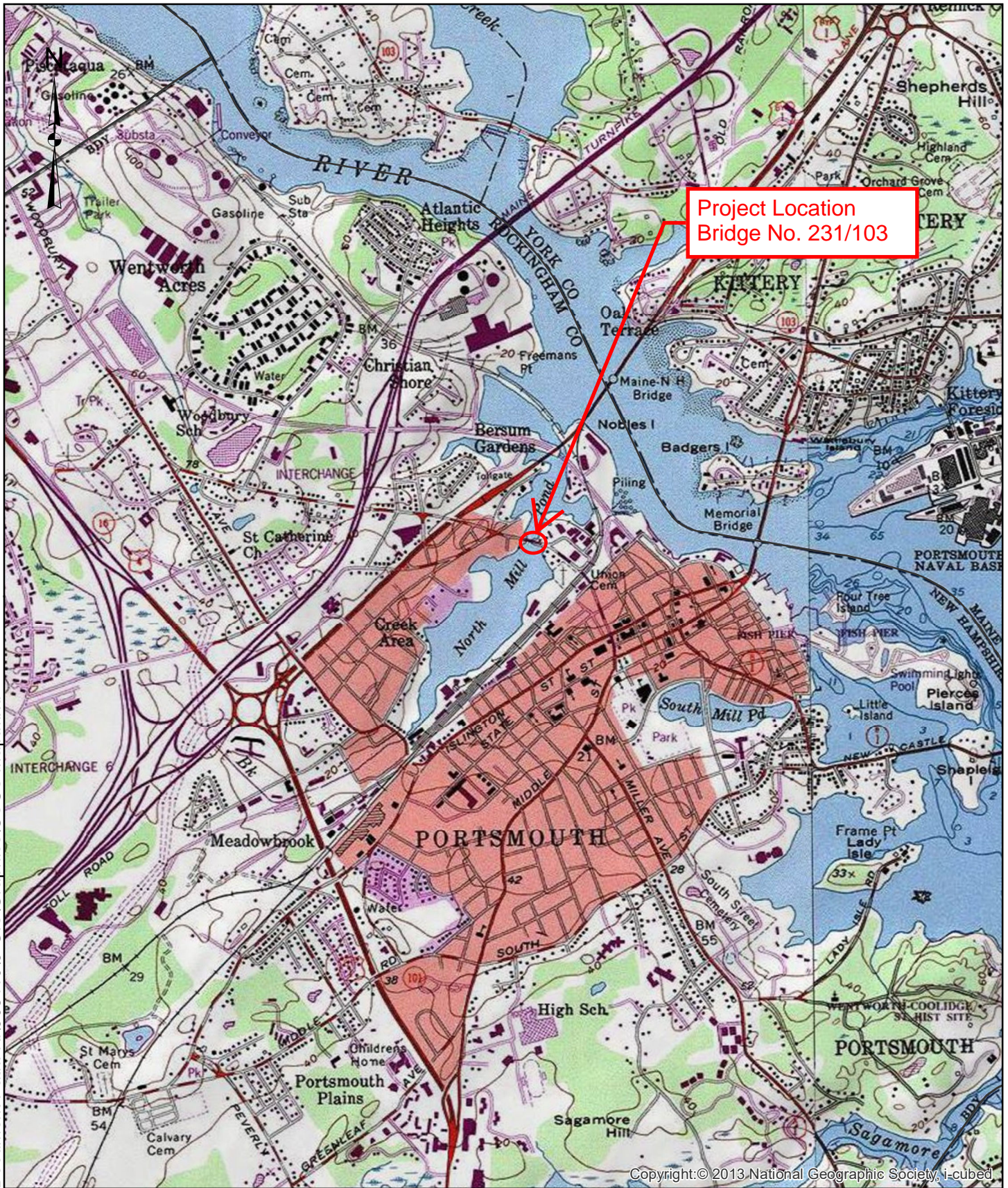

Copyright: © 2013 National Geographic Society, i-cubed

Hoyle, Tanner
 & Associates, Inc.

150 Dow Street
 Manchester, NH 03101-1227
 Tel 603-669-5555
 Fax 603-669-4168
 Web Page www.hoyletanner.com

MAPLEWOOD AVENUE BRIDGE
 OVER NORTH MILL POND
 PORTSMOUTH, NH

APPENDIX

PROJECT LOCATION MAP

A

DR. BY
dcoon

DATE
10/9/2020

SCALE
1 inch = 2,000 feet



STANDARD DREDGE AND FILL WETLANDS PERMIT APPLICATION

Water Division/Land Resources Management
Wetlands Bureau



[Check the Status of your Application](#)

RSA/Rule: RSA 482-A/Env-Wt 100-900

APPLICANT'S NAME: City of Portsmouth

TOWN NAME: Portsmouth

Administrative Use Only	Administrative Use Only	Administrative Use Only	File No.:
			Check No.:
			Amount:
			Initials:

A person may request a waiver to the requirements in Rules Env-Wt 100-900 to accommodate situations where strict adherence to the requirements would not be in the best interest of the public or the environment. A person may also request a waiver of the standards for existing dwellings over water pursuant to RSA 482-A:26, III (b). For more information, please consult the [request form](#).

Section 1 - Required Planning for all projects (Env-Wt 306.05; RSA 482-A:3, I(d)(2))	
Please use the Wetland Permit Planning Tool (WPPT) , the Natural Heritage Bureau (NHB) DataCheck Tool , the Aquatic Restoration Mapper , or other sources to assist in identifying key features such as: priority resource areas (PRAs) , protected species or habitats , coastal areas, designated rivers, or designated prime wetlands.	
Has the required planning been completed?	<input checked="" type="checkbox"/> Yes <input type="checkbox"/> No
Does the property contain a PRA? If yes, provide the following information: <ul style="list-style-type: none"> • Does the project qualify for an Impact Classification Adjustment (e.g. NH Fish and Game Department (NHF&G) and NHB agreement for a classification downgrade) or a Project-Type Exception (e.g. Maintenance or Statutory Permit-by-Notification (SPN) project)? See Env-Wt 407.02 and Env-Wt 407.04. • Protected species or habitat? <ul style="list-style-type: none"> ○ If yes, species or habitat name(s): ○ NHB Project ID #: NHB23-1686 • Bog? • Floodplain wetland contiguous to a tier 3 or higher watercourse? • Designated prime wetland or duly-established 100-foot buffer? • Sand dune, tidal wetland, tidal water, or undeveloped tidal buffer zone? 	<input checked="" type="checkbox"/> Yes <input type="checkbox"/> No <input type="checkbox"/> Yes <input checked="" type="checkbox"/> No <input type="checkbox"/> Yes <input checked="" type="checkbox"/> No <input type="checkbox"/> Yes <input checked="" type="checkbox"/> No <input type="checkbox"/> Yes <input checked="" type="checkbox"/> No <input checked="" type="checkbox"/> Yes <input type="checkbox"/> No
Is the property within a Designated River corridor? If yes, provide the following information: <ul style="list-style-type: none"> • Name of Local River Management Advisory Committee (LAC): <input style="width: 50px;" type="text"/> • A copy of the application was sent to the LAC on Month: <input style="width: 20px;" type="text"/> Day: <input style="width: 20px;" type="text"/> Year: <input style="width: 20px;" type="text"/> 	<input type="checkbox"/> Yes <input checked="" type="checkbox"/> No
For dredging projects, is the subject property contaminated? <ul style="list-style-type: none"> • If yes, list contaminant: N/A 	<input type="checkbox"/> Yes <input checked="" type="checkbox"/> No

irm@des.nh.gov or (603) 271-2147

NHDES Wetlands Bureau, 29 Hazen Drive, PO Box 95, Concord, NH 03302-0095

www.des.nh.gov

Is there potential to impact impaired waters, class A waters, or outstanding resource waters?	<input checked="" type="checkbox"/> Yes <input type="checkbox"/> No
For stream crossing projects, provide watershed size (see Wetland Permit Planning Tool or Stream Stats): 2,628 acres	
Section 2 - PROJECT DESCRIPTION (Env-Wt 311.04(i))	
Provide a brief description of the project and the purpose of the project, outlining the scope of work to be performed and whether impacts are temporary or permanent. DO NOT reply "See attached"; please use the space provided below.	
<p>The Maplewood Avenue Bridge (NHDOT Bridge No. 231/103) is a single-span stone arch bridge that was initially constructed in 1896, has a total span length of 25' and carries two lanes of traffic on a 32' wide paved roadway with sidewalks on each side. The City of Portsmouth (City) is proposing to repair the grouted corrugated metal plate arch (CMPA) liner that was installed in 1976 as part of a previous rehabilitation project. The Maplewood Avenue bridge is a heavily trafficked vital piece of infrastructure within the City as it acts as gateway to the downtown area. The bridge is currently on the State's 'Red List' of poor condition bridges due to its condition rating of 3, or 'Serious'. Closure of the bridge would be detrimental to the City and the stakeholders in the area.</p> <p>Due to the deteriorated condition of the CMPA, compromised stone arch, and limited funding sources, the City is proposing a repair project to stabilize the bridge for the protection of the traveling public. The repair will consist of installation of a spray-applied geopolymer liner to the inside surface of the metal culvert liner that will restore structural integrity. In addition, sections of the historic retaining wall supporting Maplewood Avenue will be reconstructed and stabilized with reuse of the existing stone. Supplemental riprap will be re-installed along areas of the north side inlet to protect the restored retaining walls from future tidal impacts. Drainage system improvements, roadway reconstruction and guardrail support slab replacement will mitigate the existing roadway settlement, ponding and sidewalk rotation. The service life of the repaired structure will be approximately ten to fifteen years, at which time a complete replacement would need to occur. Traffic will be managed by a combination of alternating 1-way traffic through the site and portions of complete shutdown with a detour.</p> <p>There will be 20,227 sq. ft. of temporary impacts and 537 sq. ft. of permanent impacts as a result of this project.</p>	
SECTION 3 - PROJECT LOCATION	
Separate wetland permit applications must be submitted for each municipality within which wetland impacts occur.	
ADDRESS: Maplewood Avenue	
TOWN/CITY: Portsmouth	
TAX MAP/BLOCK/LOT/UNIT: Tax Maps 123 & 124	
US GEOLOGICAL SURVEY (USGS) TOPO MAP WATERBODY NAME: North Mill Pond / <input type="checkbox"/> N/A	
(Optional) LATITUDE/LONGITUDE in decimal degrees (to five decimal places): 43.079684 / -70.765366 <i>*Approximate center location of the project area</i>	
SECTION 4 - APPLICANT (Desired permit holder) INFORMATION (Env-Wt 311.04(a))	
If the applicant is a trust or a company, then complete with the trust or company information.	
NAME: City of Portsmouth / Peter Rice	
MAILING ADDRESS: 680 Peverly Hill Rd	
TOWN/CITY: Portsmouth	STATE: NH
ZIP CODE: 03801	
EMAIL ADDRESS: price@cityofportsmouth.com	
FAX: 603.427.1539	PHONE: 603.766.1411

lrn@des.nh.gov or (603) 271-2147

NHDES Wetlands Bureau, 29 Hazen Drive, PO Box 95, Concord, NH 03302-0095

www.des.nh.gov

ELECTRONIC COMMUNICATION: By initialing here: DD, I hereby authorize NHDES to communicate all matters relative to this application electronically.

SECTION 5 - AUTHORIZED AGENT INFORMATION (Env-Wt 311.04(c))

N/A

LAST NAME, FIRST NAME, M.I.: Peace, Kimberly R.

COMPANY NAME: Hoyle, Tanner & Associates, Inc.

MAILING ADDRESS: 150 Dow Street

TOWN/CITY: Manchester	STATE: NH	ZIP CODE: 03101
-----------------------	-----------	-----------------

EMAIL ADDRESS: kpeace@hoyletanner.com

FAX: 603-669-4168	PHONE: 603-460-5205
-------------------	---------------------

ELECTRONIC COMMUNICATION: By initialing here KRP, I hereby authorize NHDES to communicate all matters relative to this application electronically.

SECTION 6 - PROPERTY OWNER INFORMATION (If different than applicant) (Env-Wt 311.04(b))

If the owner is a trust or a company, then complete with the trust or company information.

Same as applicant

NAME: [REDACTED]

MAILING ADDRESS: [REDACTED]

TOWN/CITY: [REDACTED]	STATE: [REDACTED]	ZIP CODE: [REDACTED]
-----------------------	-------------------	----------------------

EMAIL ADDRESS: [REDACTED]

FAX: [REDACTED]	PHONE: [REDACTED]
-----------------	-------------------

ELECTRONIC COMMUNICATION: By initialing here [REDACTED], I hereby authorize NHDES to communicate all matters relative to this application electronically.

Section 7 - resource-specific criteria established in Env-Wt 400, Env-Wt 500, Env-Wt 600, Env-Wt 700, or Env-Wt 900 have been met (Env-Wt 313.01(a)(3))

In accordance with Env-Wt 400 the jurisdictional areas within the project limits have been delineated by Thomas Sokoloski, CWS #127, of TES Environmental Consultants, LLC. A copy of the Wetland Description and Functions and Values Assessment Report is included with this application. The jurisdictional areas are shown on the attached wetland impact plan and the Existing Conditions plan that is stamped by the CWS.

In accordance with Env-Wt 311.01 the Report prepared by TES Environmental Consultants, LLC. includes a functional assessment. While the project will result in unavoidable impacts, the report concludes the proposed project would not be expected to cause any degradation of the functions and values associated with Mill Pond and the adjacent wetlands.

The City hereby requests a waiver of the Coastal Functional Assessment to address Env-Wt 603.04 as strict adherence to the requirements would not be in the best interest of the public or the environment. The functional assessment provided in the report by TES provides sufficient information to assess the value of the resource, and that the work to be done on the bridge cannot be completed without impacts to the single resource in the project area, thus a detailed assessment of functions is not useful when comparing potential alternatives to the work being proposed. Having the waiver granted will meet the criteria in Env-Wt 204.05.

The project is a Tier 4 stream crossing and, as such, has been designed in accordance with Env-Wt 600 and Env-Wt 900. Project specific information is contained within this permit application.

irm@des.nh.gov or (603) 271-2147

NHDES Wetlands Bureau, 29 Hazen Drive, PO Box 95, Concord, NH 03302-0095

www.des.nh.gov

Section 8 - Avoidance and Minimization

The Avoidance and Minimization Checklist is attached to this permit application.

SECTION 9 - MITIGATION REQUIREMENT (Env-Wt 311.02)

If unavoidable jurisdictional impacts require mitigation, a mitigation pre-application meeting must occur at least 30 days but not more than 90 days prior to submitting this Standard Dredge and Fill Permit Application.

Mitigation Pre-Application Meeting Date: Month: March Day: 16 Year: 2023

N/A - Mitigation is not required) See Supplemental Narrative for details.

Section 10 - The project MEETS compensatory mitigation requirements (Env-Wt 313.01(a)(1)c)

Confirm that you have submitted a compensatory mitigation proposal that meets the requirements of Env-Wt 800 for all permanent unavoidable impacts that will remain after avoidance and minimization techniques have been exercised to the maximum extent practicable: I confirm submittal. **The proposed removal of 206 square feet of fill below HOTL will offset the 38 square feet of permanent fill proposed to the extent that mitigation is not required. See Supplemental Narrative for mitigation details.**

SECTION 11 - IMPACT AREA (Env-Wt 311.04(g))

For each jurisdictional area that will be/has been impacted, provide square feet (SF) and, if applicable, linear feet (LF) of impact, and note whether the impact is after-the-fact (ATF; i.e., work was started or completed without a permit).

For intermittent and ephemeral streams, the linear footage of impact is measured along the thread of the channel. *Please note, installation of a stream crossing in an ephemeral stream may be undertaken without a permit per Rule Env-Wt 309.02(d), however other dredge or fill impacts should be included below.*

For perennial streams/ivers, the linear footage of impact is calculated by summing the lengths of disturbances to the channel and banks.

Permanent impacts are impacts that will remain after the project is complete (e.g., changes in grade or surface materials).

Temporary impacts are impacts not intended to remain (and will be restored to pre-construction conditions) after the project is completed.

JURISDICTIONAL AREA		PERMANENT			TEMPORARY		
		SF	LF	ATF	SF	LF	ATF
Wetlands	Forested Wetland			<input type="checkbox"/>			<input type="checkbox"/>
	Scrub-shrub Wetland			<input type="checkbox"/>			<input type="checkbox"/>
	Emergent Wetland			<input type="checkbox"/>			<input type="checkbox"/>
	Wet Meadow			<input type="checkbox"/>			<input type="checkbox"/>
	Vernal Pool			<input type="checkbox"/>			<input type="checkbox"/>
	Designated Prime Wetland			<input type="checkbox"/>			<input type="checkbox"/>
	Duly-established 100-foot Prime Wetland Buffer			<input type="checkbox"/>			<input type="checkbox"/>
Surface Water	Intermittent / Ephemeral Stream			<input type="checkbox"/>			<input type="checkbox"/>
	Perennial Stream or River			<input type="checkbox"/>			<input type="checkbox"/>
	Lake / Pond			<input type="checkbox"/>			<input type="checkbox"/>
	Docking - Lake / Pond			<input type="checkbox"/>			<input type="checkbox"/>
	Docking - River			<input type="checkbox"/>			<input type="checkbox"/>
Banks	Bank - Intermittent Stream			<input type="checkbox"/>			<input type="checkbox"/>
	Bank - Perennial Stream / River			<input type="checkbox"/>			<input type="checkbox"/>
	Bank / Shoreline - Lake / Pond			<input type="checkbox"/>			<input type="checkbox"/>
Tidal	Tidal Waters	38 sf		<input type="checkbox"/>	19,452 sf		<input type="checkbox"/>
	Tidal Marsh			<input type="checkbox"/>			<input type="checkbox"/>
	Sand Dune			<input type="checkbox"/>			<input type="checkbox"/>
	Undeveloped Tidal Buffer Zone (TBZ)			<input type="checkbox"/>			<input type="checkbox"/>

lrn@des.nh.gov or (603) 271-2147

NHDES Wetlands Bureau, 29 Hazen Drive, PO Box 95, Concord, NH 03302-0095

www.des.nh.gov

Previously-developed TBZ	499 sf	<input type="checkbox"/>	775 sf	<input type="checkbox"/>
Docking - Tidal Water		<input type="checkbox"/>		<input type="checkbox"/>
TOTAL	537 sf		20,227 sf	

SECTION 12 - APPLICATION FEE (RSA 482-A:3, I)

MINIMUM IMPACT FEE: Flat fee of \$400.

NON-ENFORCEMENT RELATED, PUBLICLY-FUNDED AND SUPERVISED RESTORATION PROJECTS, REGARDLESS OF IMPACT CLASSIFICATION: Flat fee of \$400 (refer to RSA 482-A:3, 1(c) for restrictions).

MINOR OR MAJOR IMPACT FEE: Calculate using the table below:

Permanent and temporary (non-docking):	20,764 SF	×	\$0.40 =	\$8,305.60
Seasonal docking structure:	SF	×	\$2.00 =	\$
Permanent docking structure:	SF	×	\$4.00 =	\$
Projects proposing shoreline structures (including docks) add \$400 =				\$
Total =				\$8,305.60

The application fee for minor or major impact is the above calculated total or \$400, whichever is greater = \$8,305.60

SECTION 13 - PROJECT CLASSIFICATION (Env-Wt 306.05)
Indicate the project classification.

Minimum Impact Project Minor Project Major Project

SECTION 14 - REQUIRED CERTIFICATIONS (Env-Wt 311.11)

Initial each box below to certify:

Initials: To the best of the signer’s knowledge and belief, all required notifications have been provided.

Initials: The information submitted on or with the application is true, complete, and not misleading to the best of the signer’s knowledge and belief.

Initials: The signer understands that:

- The submission of false, incomplete, or misleading information constitutes grounds for NHDES to:
 - Deny the application.
 - Revoke any approval that is granted based on the information.
 - If the signer is a certified wetland scientist, licensed surveyor, or professional engineer licensed to practice in New Hampshire, refer the matter to the joint board of licensure and certification established by RSA 310-A:1.
- The signer is subject to the penalties specified in New Hampshire law for falsification in official matters, currently RSA 641.
- The signature shall constitute authorization for the municipal conservation commission and the Department to inspect the site of the proposed project, except for minimum impact forestry SPN projects and minimum impact trail projects, where the signature shall authorize only the Department to inspect the site pursuant to RSA 482-A:6, II.

Initials: N/A If the applicant is not the owner of the property, each property owner signature shall constitute certification by the signer that he or she is aware of the application being filed and does not object to the filing.

SECTION 15 - REQUIRED SIGNATURES (Env-Wt 311.04(d); Env-Wt 311.11)

SIGNATURE (OWNER): _____	PRINT NAME LEGIBLY:	DATE:
SIGNATURE (APPLICANT, IF DIFFERENT FROM OWNER): _____	PRINT NAME LEGIBLY:	DATE:

SIGNATURE (AGENT, IF APPLICABLE): _____	PRINT NAME LEGIBLY: Kimberly R. Peace	DATE:
SECTION 16 - TOWN / CITY CLERK SIGNATURE (Env-Wt 311.04(f))		
As required by RSA 482-A:3, I(a),(1), I hereby certify that the applicant has filed four application forms, four detailed plans, and four USGS location maps with the town/city indicated below.		
TOWN/CITY CLERK SIGNATURE: _____	PRINT NAME LEGIBLY:	
TOWN/CITY:	DATE:	

DIRECTIONS FOR TOWN/CITY CLERK:

Per RSA 482-A:3, I(a)(1)

1. IMMEDIATELY sign the original application form and four copies in the signature space provided above.
2. Return the signed original application form and attachments to the applicant so that the applicant may submit the application form and attachments to NHDES by mail or hand delivery.
3. IMMEDIATELY distribute a copy of the application with one complete set of attachments to each of the following bodies: the municipal Conservation Commission, the local governing body (Board of Selectmen or Town/City Council), and the Planning Board.
4. Retain one copy of the application form and one complete set of attachments and make them reasonably accessible for public review.

DIRECTIONS FOR APPLICANT:

Submit the original permit application form bearing the signature of the Town/City Clerk, additional materials, and the application fee to NHDES by mail or hand delivery at the address at the bottom of this page. Make check or money order payable to "Treasurer – State of NH".



STANDARD DREDGE AND FILL
WETLANDS PERMIT APPLICATION
ATTACHMENT A: MINOR AND MAJOR PROJECTS



Water Division/Land Resources Management
Wetlands Bureau

[Check the Status of your Application](#)

RSA/ Rule: RSA 482-A/ Env-Wt 311.10; Env-Wt 313.01(a)(1); Env-Wt 313.03

APPLICANT'S NAME: City of Portsmouth

TOWN NAME: Portsmouth

Attachment A is required for *all minor and major projects*, and must be completed *in addition* to the [Avoidance and Minimization Narrative](#) or [Checklist](#) that is required by Env-Wt 307.11.

For projects involving construction or modification of non-tidal shoreline structures over areas of surface waters having an absence of wetland vegetation, only Sections I.X through I.XV are required to be completed.

PART I: AVOIDANCE AND MINIMIZATION

In accordance with Env-Wt 313.03(a), the Department shall not approve any alteration of any jurisdictional area unless the applicant demonstrates that the potential impacts to jurisdictional areas have been avoided to the maximum extent practicable and that any unavoidable impacts have been minimized, as described in the [Wetlands Best Management Practice Techniques For Avoidance and Minimization](#).

SECTION I.I - ALTERNATIVES (Env-Wt 313.03(b)(1))

Describe how there is no practicable alternative that would have a less adverse impact on the area and environments under the Department's jurisdiction.

The Maplewood Avenue bridge is a heavily trafficked vital piece of infrastructure within the City of Portsmouth as it acts as gateway to the downtown area. The bridge is currently on the State's 'Red List' of poor condition bridges due to its condition rating of 3, or 'Serious'. Closure of the bridge would be detrimental to the City and the stakeholders in the area.

There is no practicable alternative that would have a less adverse impact on the area and environments under the Department's jurisdiction than what is proposed herein. The project is a repair project that consists of the installation of a spray-applied geopolymer liner to the inside surface of the metal culvert liner to restore structural integrity. The thickness of the liner will be approximately 4.5". In addition, sections of the retaining wall supporting Maplewood Avenue will be reconstructed or stabilized with reuse of the existing stone. Replacement of riprap will be reinstalled along areas of the north side inlet to protect the restored retaining walls from future tidal impacts. Drainage system improvements, roadway reconstruction, and rail support slab replacement will mitigate the existing roadway settlement, ponding, and sidewalk rotation. The repair project will result in minimal impact to the resource as opposed to a full replacement of the structure. A proposed reduction in the bridge footing of 206 square feet will more than offset the proposed 38 square feet of permanent impacts – see Supplemental Narrative and attached plans for details.

lrn@des.nh.gov or (603) 271-2147

NHDES Wetlands Bureau, 29 Hazen Drive, PO Box 95, Concord, NH 03302-0095

www.des.nh.gov

<p>SECTION I.II - MARSHES (Env-Wt 313.03(b)(2))</p>
<p>Describe how the project avoids and minimizes impacts to tidal marshes and non-tidal marshes where documented to provide sources of nutrients for finfish, crustacean, shellfish, and wildlife of significant value.</p>
<p>Per the Report prepared by TES there are small, discontinuous fringe areas of Irregularly Flooded (Tidal) Marsh in the vicinity of the project area, however, functions and values associated with the marsh are limited given their position in the site and within the general area. The project will temporarily impact the northern marsh fringe directly adjacent to the bridge/stone wall, however this will be minimized to the extent practicable and will be evaluated upon project completion for enhancement activities as needed.</p>
<p>SECTION I.III - HYDROLOGIC CONNECTION (Env-Wt 313.03(b)(3))</p>
<p>Describe how the project maintains hydrologic connections between adjacent wetland or stream systems.</p>
<p>Installation of a 4.5” spray liner on the inside of the culvert would result in a negligible reduction in the hydraulic opening of the bridge. In order to offset the decrease in hydraulic area resulting from the geopolymer liner, portions of the concrete footings will be removed. . Refer to the attached report by Headwaters Consulting LLC for complete analysis.</p>
<p>SECTION I.IV - JURISDICTIONAL IMPACTS (Env-Wt 313.03(b)(4))</p>
<p>Describe how the project avoids and minimizes impacts to wetlands and other areas of jurisdiction under RSA 482-A, especially those in which there are exemplary natural communities, vernal pools, protected species and habitat, documented fisheries, and habitat and reproduction areas for species of concern, or any combination thereof.</p>
<p>Impacts to the wetlands are necessary to repair a deteriorating stream crossing and have been minimized to the extent practicable. There are no exemplary natural communities, vernal pools, protected species and habitat, documented fisheries, or habitat and reproduction areas for species of concern that will be affected by the project.</p>
<p>SECTION I.V – PUBLIC COMMERCE, NAVIGATION, OR RECREATION (Env-Wt 313.03(b)(5))</p>
<p>Describe how the project avoids and minimizes impacts that eliminate, depreciate or obstruct public commerce, navigation, or recreation.</p>
<p>The Maplewood Avenue bridge is a heavily trafficked vital piece of infrastructure within the City of Portsmouth as it acts as gateway to the downtown area. Repairing this structure will be to the benefit of public commerce as closure of the bridge would be detrimental to the City and the stakeholders in the area. Due to the nature of the repair project, there will be no permanent impacts to navigation or recreation. During construction, the water diversion pipes laid in the streambed will create a temporary obstruction for small watercraft that currently may occasionally pass through the crossing. This is unavoidable.</p>
<p>SECTION I.VI - FLOODPLAIN WETLANDS (Env-Wt 313.03(b)(6))</p>
<p>Describe how the project avoids and minimizes impacts to floodplain wetlands that provide flood storage.</p>
<p>The project will not impact floodplain wetlands that provide flood storage. The proposed liner will only reduce the hydraulic opening by 4.5” and will result in minimal hydraulic impacts and will not result in a loss of flood storage. Additionally, the proposed riprap is replacement of riprap that currently exists or did exist. Refer to the attached report by Headwaters Consulting LLC for complete analysis.</p>

<p>SECTION I.VII – RIVERINE FORESTED WETLAND SYSTEMS AND SCRUB-SHRUB – MARSH COMPLEXES (Env-Wt 313.03(b)(7))</p> <p>Describe how the project avoids and minimizes impacts to and scrub-shrub –marsh complexes of high ecological integrity.</p>
<p>N/A – There are no riverine forested wetland systems or scrub-shrub –marsh complexes of high ecological integrity present at the site.</p>
<p>SECTION I.VIII - DRINKING WATER SUPPLY AND GROUNDWATER AQUIFER LEVELS (Env-Wt 313.03(b)(8))</p> <p>Describe how the project avoids and minimizes impacts to wetlands that would be detrimental to adjacent drinking water supply and groundwater aquifer levels.</p>
<p>N/A</p>
<p>SECTION I.IX - STREAM CHANNELS (Env-Wt 313.03(b)(9))</p> <p>Describe how the project avoids and minimizes adverse impacts to stream channels and the ability of such channels to handle runoff of waters.</p>
<p>Upon completion of the project the proposed liner will only reduce the hydraulic opening by 4.5” and will result in minimal impact. There will be no permanent adverse impact to the stream channel nor the ability of the channel to handle runoff of waters. All impacts have been minimized to the extent practicable. Refer to the attached report by Headwaters Consulting LLC for complete analysis.</p>
<p>SECTION I.X - SHORELINE STRUCTURES - CONSTRUCTION SURFACE AREA (Env-Wt 313.03(c)(1))</p> <p>Describe how the project has been designed to use the minimum construction surface area over surface waters necessary to meet the stated purpose of the structures.</p>
<p>N/A – This project does not include any shoreline structures.</p>
<p>SECTION I.XI - SHORELINE STRUCTURES - LEAST INTRUSIVE UPON PUBLIC TRUST (Env-Wt 313.03(c)(2))</p> <p>Describe how the type of construction proposed is the least intrusive upon the public trust that will ensure safe docking on the frontage.</p>
<p>N/A – This project does not include any shoreline structures.</p>
<p>SECTION I.XII - SHORELINE STRUCTURES – ABUTTING PROPERTIES (Env-Wt 313.03(c)(3))</p> <p>Describe how the structures have been designed to avoid and minimize impacts on ability of abutting owners to use and enjoy their properties.</p>
<p>N/A – This project does not include any shoreline structures.</p>
<p>SECTION I.XIII - SHORELINE STRUCTURES – COMMERCE AND RECREATION (Env-Wt 313.03(c)(4))</p> <p>Describe how the structures have been designed to avoid and minimize impacts to the public’s right to navigation, passage, and use of the resource for commerce and recreation.</p>
<p>N/A – This project does not include any shoreline structures.</p>

<p>SECTION I.XIV - SHORELINE STRUCTURES – WATER QUALITY, AQUATIC VEGETATION, WILDLIFE AND FINFISH HABITAT (Env-Wt 313.03(c)(5))</p> <p>Describe how the structures have been designed, located, and configured to avoid impacts to water quality, aquatic vegetation, and wildlife and finfish habitat.</p> <p>N/A – This project does not include any shoreline structures.</p>
<p>SECTION I.XV - SHORELINE STRUCTURES – VEGETATION REMOVAL, ACCESS POINTS, AND SHORELINE STABILITY (Env-Wt 313.03(c)(6))</p> <p>Describe how the structures have been designed to avoid and minimize the removal of vegetation, the number of access points through wetlands or over the bank, and activities that may have an adverse effect on shoreline stability.</p> <p>N/A – This project does not include any shoreline structures.</p>
<p>PART II: FUNCTIONAL ASSESSMENT</p>
<p>REQUIREMENTS</p> <p>Ensure that project meets the requirements of Env-Wt 311.10 regarding functional assessment (Env-Wt 311.04(j); Env-Wt 311.10).</p>
<p>FUNCTIONAL ASSESSMENT METHOD USED: Wetland functions and values, and their significance were evaluated using the US Army Corps Highway Methodology guidelines.</p>
<p>NAME OF CERTIFIED WETLAND SCIENTIST (FOR NON-TIDAL PROJECTS) OR QUALIFIED COASTAL PROFESSIONAL (FOR TIDAL PROJECTS) WHO COMPLETED THE ASSESSMENT: Thomas Sokoloski</p>
<p>DATE OF ASSESSMENT: February 28, 2020</p>
<p>Check this box to confirm that the application includes a NARRATIVE ON FUNCTIONAL ASSESSMENT: <input checked="" type="checkbox"/></p>
<p>For minor or major projects requiring a standard permit without mitigation, the applicant shall submit a wetland evaluation report that includes completed checklists and information demonstrating the RELATIVE FUNCTIONS AND VALUES OF EACH WETLAND EVALUATED. Check this box to confirm that the application includes this information, if applicable: <input checked="" type="checkbox"/></p> <p>Note: The Wetlands Functional Assessment worksheet can be used to compile the information needed to meet functional assessment requirements.</p>



AVOIDANCE AND MINIMIZATION CHECKLIST

Water Division/Land Resources Management Wetlands Bureau



[Check the Status of your Application](#)

RSA/Rule: RSA 482-A/ Env-Wt 311.07(c)

This checklist can be used in lieu of the written narrative required by Env-Wt 311.07(a) to demonstrate compliance with requirements for Avoidance and Minimization (A/M), pursuant to RSA 482-A:1 and Env-Wt 311.07(c).

For construction or modification of non-tidal shoreline structures over areas of surface waters having an absence of wetland vegetation, complete only Sections 1, 2, and 4 only (or the applicable sections in [Attachment A: Minor and Major Projects \(NHDES-W-06-013\)](#)).

“A/M BMPs” stands for [Wetlands Best Management Practice Techniques for Avoidance and Minimization](#) dated 2019, published by the New England Interstate Water Pollution Control Commission (Env-Wt 102.18).

“Practicable” means available and capable of being done after taking into consideration cost, existing technology, and logistics in light of overall project purposes (Env-Wt 103.62).

SECTION 1 - CONTACT/LOCATION INFORMATION		
APPLICANT LAST NAME, FIRST NAME, M.I.: City of Portsmouth / Peter Rice		
PROJECT STREET ADDRESS: MAPLEWOOD AVE	PROJECT TOWN PORTSMOUTH	
TAX MAP/LOT NUMBER: MAPS 123 & 124		
SECTION 2 - PRIMARY PURPOSE OF THE PROJECT		
Env-Wt 311.07(b)(1)	Indicate whether the primary purpose of the project is to construct a water-access structure or requires access through wetlands to reach a buildable lot or the buildable portion thereof.	<input type="checkbox"/> Yes <input checked="" type="checkbox"/> No
<p>If you answered “no” to this question, describe the purpose of the “non-access” project type you have proposed.</p> <p>The Maplewood Avenue Bridge (NH DOT Bridge No. 231/103) is a single-span stone arch bridge that was initially constructed in 1896, has a total span length of 25’ and carries two lanes of traffic on a 32’ wide paved roadway with sidewalks on each side. The City of Portsmouth (City) is proposing to repair the grouted corrugated metal plate arch (CMPA) liner that was installed in 1976 as part of a previous rehabilitation project. The Maplewood Avenue bridge is a heavily trafficked vital piece of infrastructure within the City as it acts as gateway to the downtown area. The bridge is currently on the State’s ‘Red List’ of poor condition bridges due to its condition rating of 3, or ‘Serious’. Closure of the bridge would be detrimental to the City and the stakeholders in the area.</p> <p>Due to the deteriorated condition of the CMPA, compromised stone arch, and limited funding sources, the City is proposing a repair project to stabilize the bridge for the protection of the traveling public. The repair will consist of installation of a spray-applied geopolymer liner to the inside surface of the metal culvert liner that will restore structural integrity. In addition, sections of the historic retaining wall supporting Maplewood Avenue will be reconstructed and stabilized with reuse of the existing stone. Supplemental riprap will be re-installed along areas of the north side inlet to protect the restored retaining walls from future tidal impacts. Drainage system improvements, roadway reconstruction and guardrail support slab replacement will mitigate the existing roadway settlement, ponding and sidewalk rotation. The service life of the repaired structure will be approximately ten to fifteen years, at which time a complete replacement would need to occur.</p>		

irm@des.nh.gov or (603) 271-2147

NHDES Wetlands Bureau, 29 Hazen Drive, PO Box 95, Concord, NH 03302-0095

www.des.nh.gov

SECTION 3 - AVOIDANCE & MINIMIZATION PROJECT DESIGN TECHNIQUES		
Check the appropriate boxes below in order to demonstrate that these items have been considered in the planning of the project. Use N/A (not applicable) for each technique that is not applicable to your project.		
Env-Wt 311.07(b)(2)	For any project that proposes permanent impacts of more than one acre or that proposes permanent impacts to a Priority Resource Area (PRA), or both, whether any other properties reasonably available to the applicant, whether already owned or controlled by the applicant or not, could be used to achieve the project's purpose without altering the functions and values of any jurisdictional area, in particular wetlands, streams, and PRAs.	<input checked="" type="checkbox"/> Check <input type="checkbox"/> N/A
Env-Wt 311.07(b)(3)	Whether alternative designs or techniques, such as different layouts, construction sequencing, or alternative technologies could be used to avoid impacts to jurisdictional areas or their functions and values.	<input checked="" type="checkbox"/> Check <input type="checkbox"/> N/A
Env-Wt 311.07(b)(4) Env-Wt 311.10(c)(1) Env-Wt 311.10(c)(2)	The results of the functional assessment required by Env-Wt 311.03(b)(10) were used to select a location, and design for the proposed project that has the least impact to wetland functions.	<input checked="" type="checkbox"/> Check <input type="checkbox"/> N/A
Env-Wt 311.07(b)(4) Env-Wt 311.10(c)(3)	Where impact to wetland functions is unavoidable, the proposed impacts are limited to the wetlands with the least valuable functions on the site while avoiding and minimizing impacts to the wetlands with the highest and most valuable functions.	<input checked="" type="checkbox"/> Check <input type="checkbox"/> N/A
Env-Wt 313.01(c)(1) Env-Wt 313.01(c)(2) Env-Wt 313.03(b)(1)	No practicable alternative would reduce adverse impact on the area and environments under the department's jurisdiction and the project will not cause random or unnecessary destruction of wetlands.	<input checked="" type="checkbox"/> Check <input type="checkbox"/> N/A
Env-Wt 313.01(c)(3)	The project would not cause or contribute to the significant degradation of waters of the state or the loss of any PRAs.	<input checked="" type="checkbox"/> Check <input type="checkbox"/> N/A
Env-Wt 313.03(b)(3) Env-Wt 904.07(c)(8)	The project maintains hydrologic connectivity between adjacent wetlands or stream systems.	<input checked="" type="checkbox"/> Check <input type="checkbox"/> N/A
Env-Wt 311.10 A/M BMPs	Buildings and/or access are positioned away from high function wetlands or surface waters to avoid impact.	<input type="checkbox"/> Check <input checked="" type="checkbox"/> N/A
Env-Wt 311.10 A/M BMPs	The project clusters structures to avoid wetland impacts.	<input type="checkbox"/> Check <input checked="" type="checkbox"/> N/A
Env-Wt 311.10 A/M BMPs	The placement of roads and utility corridors avoids wetlands and their associated streams.	<input type="checkbox"/> Check <input checked="" type="checkbox"/> N/A
A/M BMPs	The width of access roads or driveways is reduced to avoid and minimize impacts. Pullouts are incorporated in the design as needed.	<input type="checkbox"/> Check <input checked="" type="checkbox"/> N/A
A/M BMPs	The project proposes bridges or spans instead of roads/driveways/trails with culverts.	<input checked="" type="checkbox"/> Check <input type="checkbox"/> N/A

A/M BMPs	The project is designed to minimize the number and size of crossings, and crossings cross wetlands and/or streams at the narrowest point.	<input type="checkbox"/> Check <input checked="" type="checkbox"/> N/A
Env-Wt 500 Env-Wt 600 Env-Wt 900	Wetland and stream crossings include features that accommodate aquatic organism passage and wildlife passage.	<input checked="" type="checkbox"/> Check <input type="checkbox"/> N/A
Env-Wt 900	Stream crossings are sized to address hydraulic capacity and geomorphic compatibility.	<input checked="" type="checkbox"/> Check <input type="checkbox"/> N/A
A/M BMPs	Disturbed areas are used for crossings wherever practicable, including existing roadways, paths, or trails upgraded with new culverts or bridges.	<input checked="" type="checkbox"/> Check <input type="checkbox"/> N/A
SECTION 4 - NON-TIDAL SHORELINE STRUCTURES		
Env-Wt 313.03(c)(1)	The non-tidal shoreline structure has been designed to use the minimum construction surface area over surfaces waters necessary to meet the stated purpose of the structure.	<input type="checkbox"/> Check <input checked="" type="checkbox"/> N/A
Env-Wt 313.03(c)(2)	The type of construction proposed for the non-tidal shoreline structure is the least intrusive upon the public trust that will ensure safe docking on the frontage.	<input type="checkbox"/> Check <input checked="" type="checkbox"/> N/A
Env-Wt 313.03(c)(3)	The non-tidal shoreline structure has been designed to avoid and minimize impacts on the ability of abutting owners to use and enjoy their properties.	<input type="checkbox"/> Check <input checked="" type="checkbox"/> N/A
Env-Wt 313.03(c)(4)	The non-tidal shoreline structure has been designed to avoid and minimize impacts to the public's right to navigation, passage, and use of the resource for commerce and recreation.	<input type="checkbox"/> Check <input checked="" type="checkbox"/> N/A
Env-Wt 313.03(c)(5)	The non-tidal shoreline structure has been designed, located, and configured to avoid impacts to water quality, aquatic vegetation, and wildlife and finfish habitat.	<input type="checkbox"/> Check <input checked="" type="checkbox"/> N/A
Env-Wt 313.03(c)(6)	The non-tidal shoreline structure has been designed to avoid and minimize the removal of vegetation, the number of access points through wetlands or over the bank, and activities that may have an adverse effect on shoreline stability.	<input type="checkbox"/> Check <input checked="" type="checkbox"/> N/A



WETLANDS RULE WAIVER OR DWELLING OVER WATER WAIVER REQUEST FORM

WATER DIVISION/LAND RESOURCES MANAGEMENT
WETLANDS BUREAU



RSA/Rule: RSA 482-A/ Env-Wt 204

Administrative Use Only	Administrative Use Only	Administrative Use Only	File No.:
			Check No.:
			Amount:
			Initials:

A person may request a waiver to requirements in Rules Env-Wt 100-900 to accommodate situations where strict adherence to the requirements would not be in the best interests of the public or the environment. A person may also request a waiver of standard for existing dwellings over water pursuant to RSA 482-A:26, III (b).

SECTION 1 - PROJECT LOCATION INFORMATION (Env-Wt 204.03(c))			
ADDRESS: Maplewood Avenue	TOWN/CITY: Portsmouth	STATE: NH	ZIP CODE: 03801
TAX MAP/LOT NUMBER: Tax Maps 123 & 124			
SECTION 2 - WAIVER REQUESTOR INFORMATION (Env-Wt 204.03(a))			
LAST NAME, FIRST NAME, M.I.: City of Portsmouth / Peter Rice			
MAILING ADDRESS: 680 Peverly Hill Rd			
TOWN/CITY: Portsmouth		STATE: NH	ZIP CODE: 03801
EMAIL ADDRESS (if available): djdesfosses@cityofportsmouth.com or if not FAX NUMBER:		DAYTIME TELEPHONE NUMBER: 603.766.1411	
SECTION 3 - APPLICANT INFORMATION (Env-Wt 204.03(b))			
If request is being made on behalf of someone else, include the following information regarding the person being represented. If requestor is the applicant, check the following box and proceed to Section 4.			
<input checked="" type="checkbox"/> Requestor is the applicant.			
LAST NAME, FIRST NAME, M.I.:			
MAILING ADDRESS:			
TOWN/CITY:		STATE:	ZIP CODE:
EMAIL ADDRESS (if available): or if not FAX NUMBER:		DAYTIME PHONE NUMBER:	

irm@des.nh.gov or (603) 271-2147

NHDES Wetlands Bureau, 29 Hazen Drive, PO Box 95, Concord, NH 03302-0095

www.des.nh.gov

SECTION 4 - WAIVER INFORMATION
<p>SECTION 4A - WAIVER TO RULE Env-Wt 100-900</p> <p><input type="checkbox"/> N/A - If you are not requesting a rule waiver, check this box and proceed to Section 4b</p>
<p>Provide the number of the specific section of each rule for which a waiver is sought (Env-Wt 204.03(d)): Env-Wt 603.04</p>
<p>Provide a complete explanation of why a waiver is being requested, including an explanation of the operational and economic consequences of complying with the requirement and, if the requested waiver would extend the duration of a permit, the reason(s) why the permit holder was not able to complete the project within the specified time (Env-Wt 204.03(f)(1)):</p> <p>The City hereby requests a waiver of the Coastal Functional Assessment to address Env-Wt 603.04 as strict adherence to the requirements would not be in the best interest of the public or the environment. The functional assessment provided in the report by TES provides sufficient information to assess the value of the resource, and the work to be done on the bridge cannot be completed without impacts to the single resource in the project area, thus a detailed assessment of functions is not useful when comparing potential alternatives to the work being proposed. Having the waiver granted will meet the criteria in Env-Wt 204.05.</p>
<p>If applicable, provide a complete explanation of the alternative that is proposed to be substituted for the requirement in Env-Wt, including written documentation or data, or both, to support the alternative (Env-Wt 204.03(g)):</p> <p>The functional assessment provided by TES provides sufficient information to meet the spirit and intent of Env-Wt 603.04 in order for us to assess impacts to the functions of the resource.</p>
SECTION 4B – DWELLING OVER WATERS WAIVER UNDER RSA 482-A:26, III(b).
<p><input checked="" type="checkbox"/> N/A - If you are not requesting a standard waiver, check this box and proceed to Section 5)</p>
<p>Identify the specific standard to which a waiver is being requested (Env-Wt 204.03(e)): RSA 482-A:</p>
<p>Provide a complete explanation of why a waiver is being requested, including a complete explanation of how the statutory criteria of RSA 482-A:26, III(b) will be met (Env-Wt 204.03(f)(2)):</p>
SECTION 5 - ADDITIONAL WAIVER INFORMATION (Env-Wt 204.03(h); Env-Wt 204.03(i))
<p>(applicable to Waivers of Rules <i>and</i> Standards under RSA 482-A:26, III(b))</p> <p>Indicate whether the waiver is needed for a limited duration and, if so, an estimate of when the waiver will no longer be needed (Env-Wt 204.03(h)):</p> <p>N/A</p>

Provide a complete explanation of why the applicant believes that having the waiver granted will meet the criteria in Env-Wt 204.05 or 204.06, as applicable (Env-Wt 204.03(i)):

Having the waiver granted will meet the criteria in Env-Wt 204.05 as follows:

(1) Granting a waiver will not result in:

a. An avoidable adverse impact on:

- 1. The environment or natural resources of the state, including but not limited to jurisdictional areas and protected species or habitat; or**
- 2. Public health or public safety;**

There is no way to address the deficiencies in the bridge without having impacts to the estuarine pond in this location. Granting the waiver will not result in additional impacts to resources or public health and safety. Impacts have been minimized to the extent practicable by proposing a spray-on liner as opposed to full replacement of the structure.

b. An impact on abutting properties that is more significant than that which would result from complying with the rule; or

Impacts to abutting properties will not change as a result of granting this waiver.

c. A statutory requirement being waived; and

This will not result in a statutory requirement being waived.

(2) Any benefit to the public or the environment from complying with the rule is outweighed by the operational or economic costs to the applicant.

The public benefit from having safe passage in this location would not change by granting this waiver. Impacts to the environment would not change as a result of granting this waiver.

SECTION 6 - REQUIRED CERTIFICATIONS (Env-Wt 204.04)

Initial each box and sign below to certify:

Initials:	The information provided is true, complete, and not misleading to the knowledge and belief of the signer.
Initials:	The signer understands that: <ul style="list-style-type: none"> • Any waiver granted based on false, incomplete, or misleading information shall be subject to revocation; and • He or she is subject to the penalties for falsification in official matters, currently established in RSA 641.

Section 7 - REQUESTOR SIGNATURE (Env-Wt 204.04)

SIGNATURE (APPLICANT): *	PRINT NAME LEGIBLY:	DATE:
_____	Peter Rice	
SIGNATURE (REQUESTOR):	PRINT NAME LEGIBLY:	DATE:

*In lieu of an applicant signature, you may include a separate signed and dated authorization for the requestor to act on the person's behalf in connection with the request.

irm@des.nh.gov or (603) 271-2147

NHDES Wetlands Bureau, 29 Hazen Drive, PO Box 95, Concord, NH 03302-0095

www.des.nh.gov

NEW HAMPSHIRE DEPARTMENT OF ENVIRONMENTAL SERVICES
WETLAND PERMIT APPLICATION
for
Repair of the Maplewood Avenue Bridge over North Mill Pond, Portsmouth, NH
Supplemental Narrative

The following information is offered as a supplement to the information provided in the Wetland Permit Application and Plans.

Explanation as to methods, timing, and manner as to how the project will meet applicable standard permit conditions required in Env-Wt 307 (Env-Wt 311.03(b)(7))

Env-Wt 307.02 (US Army Corps of Engineers (USACE) Conditions). Appendix B is attached to this permit application. The City of Portsmouth seeks and requests to receive review and approval by the Army Corps of Engineers through their General Permit via submittal of this State wetlands permit application to NHDES.

Env-Wt 307.03 (Protection of Water Quality Required). The contractor shall be responsible for implementing Erosion and Sediment control measures in accordance with the "New Hampshire Stormwater Manual, Volume 3 Erosion and Sediment Controls during Construction" by NHDES. Erosion and siltation control measures will be installed by the Contractor prior to start of any work and will be maintained during the duration of the construction activities. It is the Contractor's responsibility to not cause violations of surface water quality standards. Upon completion of the project, the project will cause no adverse effects on the quality or quantity of surface or groundwater entering or exiting the project site.

Env-Wt 307.05 (Protection Against Invasive Species Required) TES Environmental Consultants, LLC performed a Wetland Delineation of the project area and noted the following species present within the study area: Oriental bittersweet (*Celastrus orbiculatus*), glossy buckthorn (*Frangula alnus*), multiflora rose (*Rosa multiflora*), and black swallowwort (*Cynanchum louiseae*). The project contractor will be aware of and conform with the requirements in Env-Wt 307.05 and will be required to prepare an Invasive Species Management Plan to be submitted to the Contract Engineer.

Env-Wt 307.06 (Protection of Rare, Threatened or Endangered Species and Critical Habitat) The NH Natural Heritage Bureau was contacted regarding the proposed project (see attached letter NHB23- 1686, dated 6/1/2023). The database check resulted in a finding of no recorded occurrences for sensitive species near this project area.

During a pre-application/mitigation meeting a request was made to consult with New Hampshire Fish and Game (NHFG) with respect to potential impacts to Atlantic or shortnose sturgeon as a result of the project. In an email received June 9, 2023 NHFG commented "we do not expect impacts to Atlantic or shortnose sturgeon as a result of this project". Additionally, a request was made to have some conditions be incorporated into the permit. These conditions have been noted on the plans on Sheet 8 of 20. A copy of the email from NHF&G is included with this permit application.

An official Federally-listed species list was obtained from the US Fish and Wildlife Service (USFWS) using the Information for Planning and Conservation (IPAC) online tool on June 09, 2023 (Project Code: 2023-0010149). The list includes the Federally-threatened Northern Long Eared Bat (*Myotis septentrionalis*; NLEB) and Roseate Tern (*Sterna dougallii dougallii*).

Tree removal is limited to (6) - 10" DBH trees and (5) - 8" DBH trees that will be removed outside of the USFWS time of year restriction for NLEB. The project was reviewed for potential effects to NLEB using the key within the IPAC system. Per the attached documentation, Project Code 2023-0010149, the proposed action is not likely to result in unauthorized take of the northern long-eared bat.

The project was reviewed for potential effects to Roseate Tern using the key within the IPAC system. Per the Verification Letter issued for the project, the proposed action received a determination of "No Effect" based on responses to the USFWS Northeast DKey.

The ESA consultation status is incomplete, and no project activities should occur until consultation between the Service and the Federal action agency (USACE), is completed. This consultation will be completed during USACE's review of the application and prior to issuance of the USACE GP for the project.

Copies of the species list and documentation are included with this permit application.

Env-Wt 307.07 (Consistency Required with Shoreland Water Quality Protection Act). North Mill Pond is subject to the Shoreland Water Quality Protection Act (SWQPA) (NH RSA 483-B) however, there will be no impacts to the shoreland as the 100-ft Tidal Buffer Zone (TBZ) is a wetland resource. There are no impacts beyond the TBZ. Therefore, a Shoreland Permit Application is not required for the project.

Env-Wt 307.12 (Restoring Temporary Impacts: Site Stabilization) Upon completion of the project all temporary impact areas will be restored to preconstruction condition per the requirements listed in Env-Wt 307.12.

Env-Wt 307.13 (Property Line Setbacks). Permission letters have not been requested as one property has an existing easement in place for Tax Map 123 / Lot 8. Memorandums of Understanding will be required from two abutters where the jurisdictional impacts are within 10' of their property (Tax Map 127 / Lot 10 and Tax Map 124 / Lot 7-1 & 7.2). The City will be obtaining these Memorandums of Understanding prior to the start of construction and requests that these documents be conditioned as a part of this permit. A copy of the existing easement is included with this application.

Env-Wt 307.15 (Use of Heavy Equipment in Wetlands) There will be no heavy equipment in the wetlands for construction of this project. All heavy equipment will be located on the road or sideslopes adjacent to the bridge above HOTL.

Env-Wt 307.16 (Adherence to Approved Plans Required) All work shall be in accordance with the plans prepared by Hoyle, Tanner and approved by NHDES.

Construction Sequence and Timing

The construction sequence for the project is as follows:

1. Install traffic control signage and maintain one-way alternating traffic. Maintain pedestrian access via an existing sidewalk.
2. Install temporary erosion control measures as detailed in the Stormwater Pollution Prevention Plan.
3. Install water diversion structure prior to performing work that may impact the tidal area.
4. Install traffic control signage and detour traffic around the project site. Close bridge to vehicular traffic. Maintain pedestrian access via an existing sidewalk.
5. Remove the existing footings as outlined in the plans.
6. Prepare existing CMP culvert and apply geopolymer liner.

7. Reconstruct NW portion of retaining wall as outlined in the plans.
8. Topside grout injection to fill voids in bridge backfill and address settlement behind the bridge.
9. Install traffic control signage and maintain one-way alternating traffic. Maintain pedestrian access via an existing sidewalk.
10. Reconstruct north side rail support slab and install new guardrail, maintain pedestrian access on the southern sidewalk. Complete storm drainage improvements in NW quadrant of site. Re-install supplemental riprap in NE quadrant.
11. Reconstruct south side rail support slab and install new guardrail, maintain pedestrian access on the northern sidewalk. Repoint bulging top three courses of southern retaining wall. Complete storm drainage improvement in SE quadrant of site.
12. Remove water diversion structure.
13. Complete roadway reconstruction and final storm drainage improvements

The current schedule is to construct the project in the spring of 2024. The project is expected to be completed within one construction season, lasting approximately 21 weeks.

Statement of whether the applicant has received comments from the local conservation commission and, if so, how the applicant has addressed the comments (Env-Wt 311.06(h))

A copy of this wetland permit application was submitted to the City of Portsmouth for distribution to the Portsmouth Conservation Commission concurrent with submittal of the application to NHDES. Comments from the Commission will be forwarded to DES from Hoyle Tanner should they be received.

Federal Agency Coordination

A USACE General Permit will be required for this project. Pre-application coordination with USACE occurred during the pre-application meeting with NHDES, see meeting minutes attached. See section below for Appendix B and Checklist answers. Coordination with the US Fish and Wildlife Service (USFWS) has not been completed. While the project was cleared using the online IPAC system to generate documentation for protected species, the potential to impact northern long-eared bats (NLEB) will require additional coordination. USACE as the lead federal agency will complete the coordination for NLEB prior to issuing the GP for the project. No further coordination is required for Roseate Tern.

Riprap Re-Installation

The area shown as temporary impact for riprap re-installation is necessary for protection of the bridge's substructure and the wall. Re-installation of riprap will be as shown on the plans and consists of replacement of riprap where riprap was installed during previous stabilization efforts and will not include placement of new structural components (riprap) in locations where none existed previously.

Photos are being provided that identify the locations where riprap was installed during previous stabilization efforts; Class VII riprap will be placed and limited to within these footprints only, as shown on the plans provided. This sized riprap is supported by the hydraulic analysis attached to this application. During the pre-application meeting, comments from DES included suggested soft bank stabilization- this is not feasible for the locations for riprap re-placement as the riprap will be placed along the bridge supporting wall and not within a bank area, is designed to provide for scour prevention and protection of the stability of the stone wall and bridge and is sized based on standard engineering practices.



Locations of proposed riprap re-installation



Locations of proposed riprap re-installation with some remaining riprap visible

Please refer to the attached NHDOT riprap specifications for sizing information of Class VII riprap.

Mitigation

Per Env-Wt 904.06, compensatory mitigation is required because the stream crossing repair is located on a Tier 4 crossing, and due to the installation of a spray liner, the project is not self-mitigating. The amount of fill from the liner below HOTL would be approximately 38 square feet. Channel impacts were not included as there will be no permanent impacts to the channel as a result of the application of the liner. In order to offset these impacts, approximately 206 square feet of existing fill will be removed from the concrete bridge footings. No compensatory mitigation is proposed as the offset results in a reduction in fill below MHW/HOTL.

NOTES AND ASSUMPTIONS

- There are large voids present in the existing riprap in the NE quadrant of the bridge. The existing riprap was likely not lost due to scour activity but due to the old sewer pipe installation along the slope. This pipe will be removed and filled in as a part of this project.
- The large voids between the existing riprap will be supplemented with stone of approximately the same size as the existing stones.
- Riprap outside of the sewer pipe installation area has performed well, therefore, by inspection, this size riprap will be sufficient moving forward.
- NHDOT Standard Specifications 2016 is used for specifying the riprap.
- By inspection, the NHDOT class of riprap that most resembles the existing stones is Class VII.



The photo above shows the existing stones and voids between the stones on the slope in the NE quadrant.

Table 583-1

Riprap Classes and Sizes			Percentage Distribution of Particle Sizes by Volume (cubic feet)			
Class	Nominal Size (in)	Maximum Size (in)	< 15%	15% – 85%	> 85%	Maximum
I	6	12	0.05	0.14	0.31	1.0
III	12	24	0.4	1.0	2.5	6.5
V	18	36	1.3	3.5	8.5	22
VII	24	48	3	8	19	53
IX	36	72	10	27	65	179

Note: Nominal Size and Maximum Size are based on the Width dimension of the stone. The riprap classes conform to the standard classes described in the FHWA HEC-23 publication.

The Table above is taken from NHDOT Standard Specifications Section 583.

Pre-Application & Mitigation Meeting Notes

Projects: Maplewood Avenue Bridge Repair & CSO Outfall, Portsmouth NH

Meeting Date: March 16, 2023

Page 1 of 2

1. Attendees

- NHDES Wetlands (NHDES)
 - Kristin Duclos
 - David Price
 - Mary Ann Tilton
- US Army Corps of Engineers (USACE)
 - Lindsey Lefebvre
- Environmental Protection Agency (EPA)
 - Jean Brochi
- NH Natural Heritage Bureau (NHB)
 - Ashley Litwinenko
- City of Portsmouth (COP)
 - Dave Desfosses
- Hoyle Tanner & Associates (Hoyle Tanner)
 - Aaron Lachance
 - Kimberly Peace
 - Deb Coon
- Underwood Engineers
 - Dan Rochette
 - Jake Stoddard

Kimberly Peace started the meeting explaining there are two separate projects involving two different consultants that will be permitted separately however both are located on Mill Pond in Portsmouth and so some resource documentation will be shared by the two projects. She then gave an overview of the resources in the area.

Aaron Lachance gave a description of Maplewood Avenue bridge repair project and Dan Rochette provided a description of the drainage outfall project.

The following is list of items discussed during the meeting:

- Kimberly Peace stated the bridge project will have no permanent impacts below the High Tide Line (HTL) to the jurisdictional stream resource and asked if the project could be permitted using the USACE General Permit. Lindsey Lefebvre stated this project will require ESA & EFH coordination and needs to be done on the Federal Agency to Federal Agency level. She also stated that she can start this coordination prior to the permit application submission but would need a more refined plan to do so.
- Kimberly Peace stated that bridge repair liner will result in a total of 9.75 square feet of permanent fill below Mean High Water (MHW) and below the Highest Observable Tide Line (HOTL), triggering NHDES mitigation requirements, and the City's preferred method of mitigation is to make payment to the ARM fund. She also asked if this would need to go to Governor & Executive Council (G&C) for approval. DES confirmed it would need to be approved by G&C due to fill in public waters.
- David Price stated the outfall project will involve work within the tidal buffer, protected shoreland and fill below the HOTL. A shoreland permit will be required and the project will be classified as "major" impact and will require G&C approval. Dan Rochette

Pre-Application & Mitigation Meeting Notes

Projects: Maplewood Avenue Bridge Repair & CSO Outfall, Portsmouth NH

Meeting Date: March 16, 2023

Page 2 of 2

acknowledged the major impact permit and said they would be submitting a Shoreland Permit by Notification for the project.

- Lindsey Lefebvre stated regrading for the replacement headwall would be considered a permanent impact not temporary as shown on the plans and would require mitigation as it is a change to what is currently present. Dan Rochette acknowledged this comment and took no exception.
- NHB reports indicate no impact to protected species, Ashley Litwinenko reverified information and stated that while the reports are correct, Sturgeon is identified approximately .5 mile from the site. Dave Price stated that coordination with NHF&G should still occur.
- Lindsey Lefebvre stated that the online Section 7 Mapper can be used to identify sturgeon.
- Jean Brochi stated even though there may not be any comments during this meeting it is important to note that doesn't mean the agencies will not have comments once the applications are received and are reviewed.
- Kimberly Peace stated for the bridge project we will be asking for a waiver for a limited Coastal Functional Assessment due to the nature of the project.
- Mary Ann Tilton asked about the functional assessment. Kimberly Peace stated while the installation of the spray on liner will result in a slight change in water velocity, the increase in water elevation will be less than 1%.
- Mary Ann Tilton asked if there will be new riprap proposed for the crossing. Kimberly Peace stated there will be no new riprap, only replacement of what was already there. Mary Ann Tilton stated there may be an opportunity to explore soft stabilization in the area.
- Mary Ann Tilton asked if there will be tidal buffer impacts. Kimberly Peace stated yes there would be tidal buffer impacts but there will be no ground disturbance and consists of vegetation removal. Mary Ann Tilton asked that the design team look into the potential for re-plantings.
- Dave Price stated a point score for removal of trees associated with drainage improvements added to the bridge work will need to be submitted for the shoreland permit.
- Dave Price asked when the permits were expected to be submitted. Kimberly Peace stated both projects are looking to be submitted in the near future and that the bridge project could be at the end of April.
- Dan Rochette asked if the outfall project should consider a soft shoreline for the grading impact associated with the project. Mary Ann Tilton stated while these types of stabilization methods are encouraged it is complex in that the site needs to be evaluated to ensure that the soft shoreline will survive in the location.
- Dave Price stated the stone pad on the outfall plan looks aggressive and would like to see a reduction in area. Dan Rochette said they would revisit the stone pad size and reduce it as practical.

Tier 4 Stream Crossing Requirements
Repair of the Maplewood Avenue Bridge over North Mill Pond, Portsmouth, NH

In addition to the requirements from Env-Wt 300 addressed prior, the following is also required to address a Tier 4 Stream Crossing:

Env-Wt 603.03 Data Screening

The required data screening was completed and information is provided on plans and within the reports attached.

Env-Wt 603.04 Coastal Functional Assessment

The City hereby requests a waiver of the Coastal Functional Assessment to address Env-Wt 603.04 as strict adherence to the requirements would not be in the best interest of the public or the environment. The functional assessment provided in the report by TES provides sufficient information to assess the value of the resource, and that the work to be done on the bridge cannot be completed without impacts to the single resource in the project area, thus a detailed assessment of functions is not useful when comparing potential alternatives to the work being proposed. Having the waiver granted will meet the criteria in Env-Wt 204.05. The Waiver request form is included in this application.

Env-Wt 603.05 Vulnerability Assessment

See attached report prepared by Headwaters Consulting, LLC dated August 23, 2023 that addresses this section in its entirety.

Env-Wt 603.07 and 603.08

Data provided is included on design plans and within the Doucet tidal study included in the Headwaters hydraulic analysis report.

Env-Wt 603.09 Statement Regarding Impact on Navigation and Passage.

The project does not propose to construct a new structure in tidal waters/wetlands or to extend an existing structure seaward. The water diversion pipes will temporarily impede existing public passage along the subject shoreline by non-motorized watercraft, however these structures will be in place the least amount of time as is feasible to complete the project and the impediments have been minimized to the greatest extent practicable.

Env-Wt 904.01 General Design Considerations

(a) All stream crossings, whether over tidal or non-tidal waters, shall be designed and constructed so as to:

(1) Not be a barrier to sediment transport;

The proposed bridge repair will not result in a barrier to sediment transport in this location.

(2) Not restrict high flows and maintain existing low flows;

In order to offset the decrease in hydraulic area resulting from the geopolymer liner, portions of the concrete bridge footings will be removed. Therefore, the project will not result in restriction of high flows and will continue to maintain existing low flows upon completion.

(3) Not obstruct or otherwise substantially disrupt the movement of aquatic organisms indigenous to the waterbody beyond the actual duration of construction;

The project is a bridge repair and as such, once complete, will not result in a change of the movement of aquatic organisms indigenous to the waterbody to what currently exists.

(4) Not cause an increase in the frequency of flooding or overtopping of banks;

The proposed bridge repair will not result in an increase in the frequency of flooding or overtopping of banks.

(5) Maintain or enhance geomorphic compatibility by:

- a. Minimizing the potential for inlet obstruction by sediment, wood, or debris; and
- b. Preserving the natural alignment of the stream channel;

Geomorphic compatibility will be maintained as the opening of the crossing is 210 +/- SF which currently does not result in obstructions within the opening. Even with the proposed repair of the culvert, the opening will not be altered in such a way that it would have the potential to be obstructed. Additionally, there will be no impacts as result of the project that would result in a permanent alteration of the natural alignment of the stream channel. The stream channel under the temporary water diversion pipes will be evaluated upon project completion to determine if stream restoration is necessary, and if so, such efforts will be implemented.

(6) Preserve watercourse connectivity where it currently exists;

The proposed repair will not disrupt the watercourse connectivity.

(7) Restore watercourse connectivity where:

Not Applicable

- a. Connectivity previously was disrupted as a result of human activity(ies); and
- b. Restoration of connectivity will benefit aquatic organisms upstream or downstream of the crossing, or both;

(8) Not cause erosion, aggradation, or scouring upstream or downstream of the crossing; and

The proposed project includes re-installation of riprap where it once existed that is necessary for protection of the substructure and prevention of scour along the bridge supporting walls.

(9) Not cause water quality degradation.

The proposed project will not cause water quality degradation with the exception of temporary sediment movement that will be contained using perimeter controls and standard best management practices during construction.

(b) For stream crossings over tidal waters, the stream crossing shall be designed to:

- (1) Match the velocity, depth, cross-sectional area, and substrate of the natural stream; and
- (2) Be of sufficient size to not restrict bi-directional tidal flow over the natural tide range above, below, and through the crossing.

See attached report prepared by Headwaters Consulting, LLC dated August 23, 2023.

(c) Tier 2, tier 3, and tier 4 stream crossings shall be designed:

- (1) To meet the general design considerations specified in Env-Wt 904.01;
- (2) Of sufficient size to accommodate the greater of:
 - a. The 100-year 24-hour design storm;
 - b. Flows sufficient to:
 1. Prevent an increase in flooding on upstream and downstream properties; and
 2. Not affect flows and sediment transport characteristics in a way that could adversely affect channel stability; or
 - c. Applicable federal, state, or local requirements;
- (3) With the bed forms and streambed characteristics necessary to cause water depths and velocities within the crossing structure at a variety of flows to be comparable to those found in the natural channel upstream and downstream of the stream crossing;
- (4) To provide a vegetated bank on both sides of the watercourse or to provide a wildlife shelf of suitable substrate and access to allow for wildlife passage;
- (5) To preserve the natural alignment and gradient of the stream channel, so as to accommodate natural flow regimes and the functioning of the natural floodplain;
- (6) To simulate a natural stream channel;
- (7) So as not to alter sediment transport competence; and
- (8) To avoid and minimize impacts to the stream in accordance with Env-Wt 313.03

See answers provided above, Section Env-Wt 904.01 General Design Considerations and the attached report prepared by Headwaters Consulting, LLC dated August 23, 2023.

Env-Wt 903.05 Information Required for Certain Stream Crossing Standard Permit Applications

(f) For tier 4 crossings, a narrative explanation of the effect of the crossing on the tidal hydrograph, and the corresponding effect on the upstream and downstream tidal resource.

See attached report prepared by Headwaters Consulting, LLC dated August 23, 2023, that addresses this section.

Env-Wt 904.07 Design Criteria for Tier 2, Tier 3, and Tier 4 Stream Crossings.

(d) In addition to meeting the criteria specified in (c), above, new, repaired, rehabilitated, or replaced tier 4 stream crossing shall be designed:

- (1) Based on a hydraulic analysis that accounts for daily fluctuating tides, bidirectional flows, tidal inundation, and coastal storm surge;
- (2) To prevent creating a restriction on tidal flows; and
- (3) To account for tidal channel morphology and potential impacts due to sea level rise.

See attached report prepared by Headwaters Consulting, LLC dated August 23, 2023, that addresses this section.

Env-Wt 904.09 Repair, Rehabilitation, or Replacement of Tier 3 and Tier 4 Existing Legal Crossings.

(a) The repair, rehabilitation, or replacement of tier 3 stream crossings shall be limited to existing legal crossings where the tier classification is based only on the size of the contributing watershed.

The existing crossing is a legal crossing.

(b) Rehabilitation of a culvert or other closed-bottom stream crossing structure pursuant to this section may be accomplished by concrete repair, slip lining, cured-in place lining, or concrete invert lining, or any combination thereof, except that slip lining shall not occur more than once.

The rehabilitation project proposes slip-lining of the culvert that has not been previously slip lined.

(c) A project shall qualify under this section only if a professional engineer certifies, and provides supporting analyses to show, that:

- (1) The existing crossing does not have a history of causing or contributing to flooding that damages the crossing or other human infrastructure or protected species habitat; and
- (2) The proposed stream crossing will:
 - a. Meet the general criteria specified in Env-Wt 904.01;
 - b. Maintain or enhance the hydraulic capacity of the crossing;
 - c. Maintain or enhance the capacity of the crossing to accommodate aquatic organism passage;
 - d. Maintain or enhance the connectivity of the stream reaches upstream or downstream of the crossing; and
 - e. Not cause or contribute to the increase in the frequency of flooding or overtopping of the

banks upstream or downstream of the crossing.

The project plans included in this application have been stamped/certified by the professional engineer who designed the repair. Additionally, the report prepared by Headwaters Consulting, LLC dated August 23, 2023 has been stamped/certified by the professional engineer who prepared the hydraulic analysis and back up materials.

(d) Repair, rehabilitation, or replacement of a tier 4 stream crossing shall comply with Env-Wt 904.07(d).:

See answers provided above, Section Design Criteria for Tier 2, Tier 3, and Tier 4 Stream Crossing.

**Information Required under Env-Wt 903.05(f),
Env-Wt 904.07(d), and Env-Wt 603.05**

for

**Maplewood Avenue over North Mill Pond Bridge
Rehabilitation Project**

and

North Mill Pond Drainage Outfall Project

Portsmouth, New Hampshire



Prepared For:

Hoyle, Tanner & Associates, Inc.
Pease International Tradeport
100 International Drive, Suite 360
Portsmouth, NH 03801

Prepared by:

Headwaters Consulting, LLC
P.O. Box 744
Littleton, NH 03561

August 23, 2023



TABLE OF CONTENTS

A. INTRODUCTION	1
B. Env-Wt 903.05(f)	1
B.1 Hydraulic Model Geometry – All Models	1
B.2 Pre-Project Bridge Geometry	3
B.3 Post-Project Bridge Geometry	6
B.4 Roughness.....	7
B.5 Boundary Conditions	9
B.6 Additional Modeling Parameters.....	11
B.7 Analysis Results – MHHW	11
B.8 Analysis Results – MLLW	13
B.9 Tidal Resource Impact	15
C. Env-Wt 904.07(d)	15
C.1 Pre- and Post-Project MHHW Models without SLR.....	18
C.2 Pre- and Post-Project MLLW Models without SLR	19
C.3 Pre- and Post-Project MHHW Models with SLR	20
C.4 Pre- and Post-Project MLLW Models with SLR	23
C.5 Boundary Conditions for 50- and 100-year Storm Models	27
C.6 Pre- and Post-Project 50-year Storm Models without SLR.....	31
C.7 Pre- and Post-Project 100-year Storm Models without SLR.....	36
C.8 Pre- and Post-Project 50-year Storm Models with SLR	39
C.9 Pre- and Post-Project 100-year Storm Models with SLR	43
D. Env-Wt 603.05 Vulnerability Assessment	47
D.1 Env-Wt 603.05(a).....	47
D.2 Env-Wt 603.05(b).....	47
D.3 Env-Wt 603.05(c)	49
D.4 Env-Wt 603.05(d) and (e)	50
D.5 Env-Wt 603.05(f)	51
D.6 Env-Wt 603.05(g).....	51

APPENDICES

APPENDIX 1 – SUPPORTING DOCUMENTATION FOR HYDRAULIC MODELS

APPENDIX 2 – BRIDGE REHABILITATION PROJECT HYDROLOGY STUDY REPORT

APPENDIX 3 – DRAINAGE OUTFALL PROJECT PRE-PROJECT HYDROLOGY CALCULATIONS

APPENDIX 4 – DRAINAGE OUTFALL PROJECT POST-PROJECT HYDROLOGY CALCULATIONS

A. Introduction

This report describes the hydrologic and hydraulic analyses completed to support a NHDES Wetlands Permit application for the Maplewood Avenue over North Mill Pond Bridge Rehabilitation Project and the North Mill Pond Drainage Outfall Project in Portsmouth, NH. More specifically, this report includes the information required under sections Env-Wt 903.05(f), Env-Wt 904.07(d), and Env-Wt 603.05 of the NHDES administrative rules.

B. Env-Wt 903.05(f)

Env-Wt 903.05(f) requires “a narrative explanation of the effect of the crossing on the tidal hydrograph, and the corresponding effect on the upstream and downstream tidal resource.” Since the drainage outfall project does not include a tidal waterway crossing, only the effects of the bridge rehabilitation project on tidal conditions have been evaluated.

Two-dimensional (2D) unsteady flow models which simulate existing (i.e., pre-project) conditions and proposed (i.e., post-project) conditions with the geopolymer liner applied and portions of the existing above-grade concrete footings removed have been developed to evaluate the effect of the proposed bridge rehabilitation work on the tidal hydrograph and North Mill Pond. The models were created using the U.S. Army Corps of Engineers HEC-RAS program (version 6.3). To understand the effects of the proposed bridge rehabilitation work across a range of tidal conditions, pre- and post-project models were developed using two different tide stage hydrographs – one simulating a tide stage crest equal to mean higher-high water (MHHW) and one simulating a tide stage trough equal to mean lower-low water (MLLW). Comparisons between the pre- and post-project models were used to identify changes to maximum and minimum water levels and timing of the high and low tides caused by the rehabilitation work. The following sections describe the development of these models and the analysis results.

B.1. Hydraulic Model Geometry – All Models

The hydraulic models cover an area from a point on Hodgson Brook (a.k.a. Hodgdon Brook) about 1,200 feet southwest (upstream) from Bartlett Street to a point in North Mill Pond approximately 500 feet north of Maplewood Avenue. Model geometry was developed from a combination of field survey data and publicly-available LiDAR data (Coastal New Hampshire - 2014 data set). With the exception of the area in the vicinity of the bridge, the same geometry was used in all of the models.

The LiDAR data does not include below-water ground elevations (i.e., bathymetry), geometry of the corrugated metal arch bridge at Maplewood Avenue, or geometry of the box culvert at Bartlett Street; therefore, this information was field surveyed. Bathymetry of North Mill Pond within the study area was surveyed by Doucet Survey, LLC in late 2019 and early 2020. The Doucet survey also included topography along about 800 feet of Maplewood Avenue, portions of the shoreline north and south of the road, and other above-water areas in the project vicinity. However, it did not include detailed geometry of the existing bridge, bathymetry at the bridge inlet or outlet, geometry of the box culvert at Bartlett Street, or channel bottom elevations at the box culvert inlet or outlet; therefore, this information was field surveyed by Headwaters Consulting, LLC in September 2020. All field survey data was collected relative to NH State Plane coordinates and NAVD88 elevations, which are the same coordinate system and elevation datum the LiDAR data is referenced to (though the LiDAR

data was converted from metric to U.S. customary units). This allowed the field survey data to be merged with the LiDAR data to produce a comprehensive digital elevation model (DEM) of the study area. Figure 1 shows the hydraulic study area DEM with the Doucet field survey area outlined in red and the Headwaters field survey areas outlined in blue. Terrain information in all other areas was generated from LiDAR data.

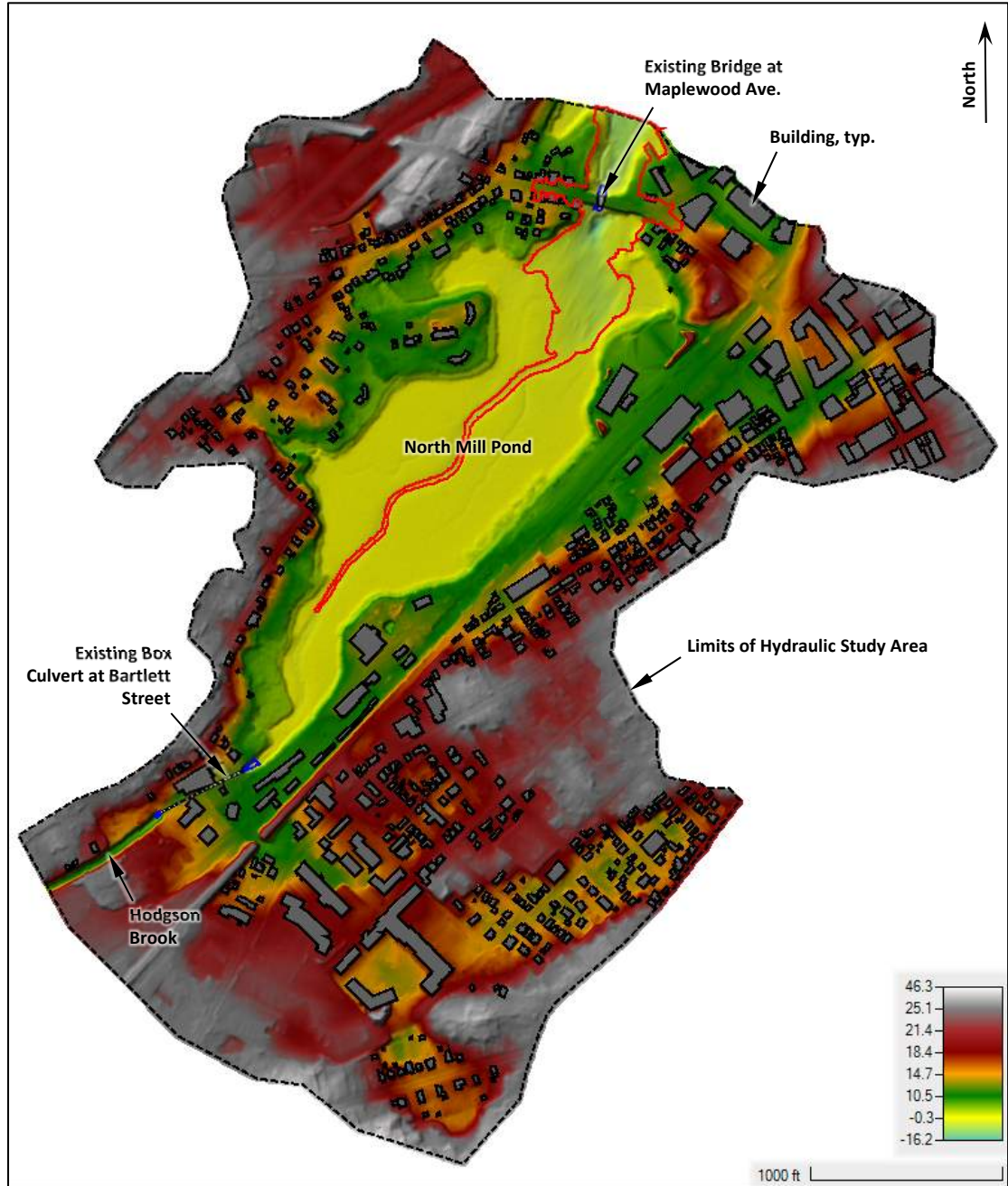

Figure 1 – Existing conditions digital elevation model (DEM) of the hydraulic study area showing areas field surveyed by Doucet Survey, LLC outlined in red and areas field surveyed by Headwaters Consulting, LLC outlined in blue

As shown in Figure 1, there are many buildings within the hydraulic study area. The building footprints were provided by the City of Portsmouth in GIS format and were uniformly assigned

an elevation value of 30 feet in the DEM so that they would be recognized as flow obstructions in the model.

A 2D computational mesh with a 25-foot x 25-foot cell size was overlaid on the DEM. Breaklines were defined along the tops of embankments and other elevated features which obstruct the flow (e.g., Maplewood Avenue) to prevent the model from calculating flow over them before they are actually overtopped. Figure 2 shows the computational mesh layout in the vicinity of Maplewood Avenue for the pre-project hydraulic models.

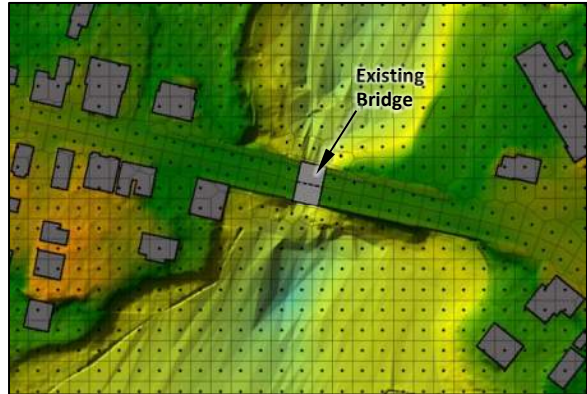

Figure 2 – Computational mesh in the vicinity of Maplewood Avenue used in the pre-project hydraulic models

B.2. Pre-Project Bridge Geometry

Figure 3 shows a photo of the existing bridge inlet and Figures 4 and 5 show cross-sections at the existing bridge inlet and outlet. [Note that although there is bi-directional flow through the bridge, for the purposes of this study the bridge inlet is on the south side of Maplewood Avenue and the bridge outlet is on the north side of the road.] Geometries of the metal arch, concrete footings, and channel bottom are based on field survey data collected by Headwaters Consulting, LLC collected in September 2020. The roadway embankment geometries were determined from the Doucet Survey, LLC survey information.

A 24-inch diameter sanitary sewer main passes through the bridge opening about 15 feet south of the bridge outlet (see Figures 3 and 6). The size, location, and elevation of the sewer main were estimated from a 2009 plan by Haight Engineering, PLLC¹ and superimposed on the existing bridge outlet section (Figure 5).

¹ Existing Profile Plan, Maplewood Ave Culvert Replacement & North Mill Pond Restoration, Portsmouth, NH, prepared by Haight Engineering, PLLC, Sheet C-4, date: 12-30-2009



Figure 3 – View north at the existing bridge inlet (09-23-20)

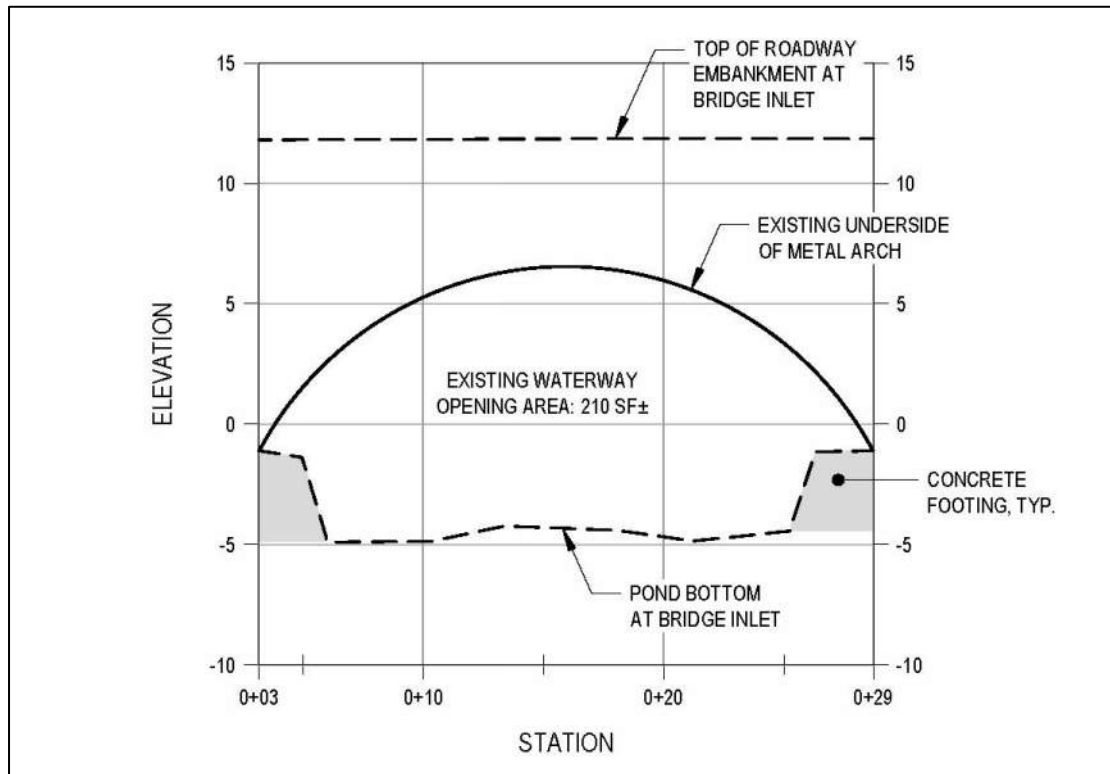

Figure 4 – Existing bridge inlet cross-section

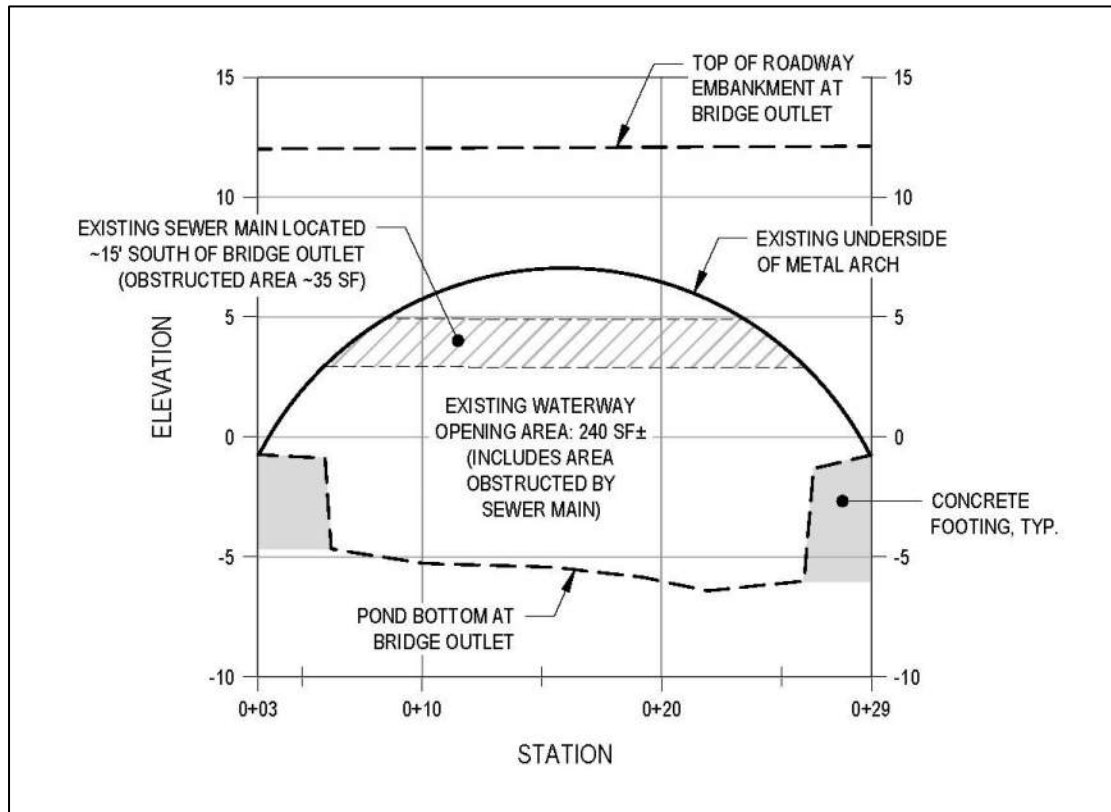

Figure 5 – Existing bridge outlet cross-section

Since the HEC-RAS bridge hydraulics routine computes flow through the bridge only at the inlet and outlet, the true effect of the sewer main cannot be modelled directly. Therefore, in an attempt to estimate its impact, the waterway opening at the bridge outlet was reduced by an area equal to the area obstructed by the sewer main, which is shown to be approximately 35 square feet on the 2009 Haight Engineering plan. Figure 7 shows the bridge outlet section as coded in the pre-project models to account for the sewer main. The waterway opening area at the bridge outlet is approximately 240 square feet when the sewer main obstruction is disregarded. The modeled waterway opening area at the bridge outlet is about 205 square feet.



Figure 6 – View north within the existing bridge opening showing the sewer main (09-23-20)

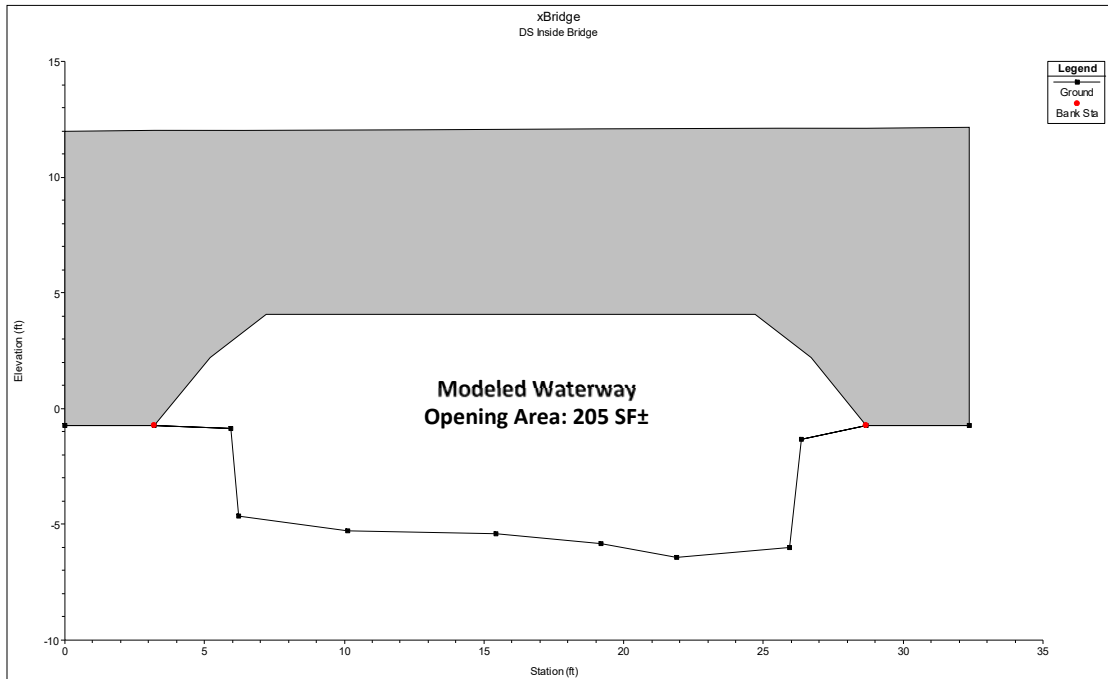

Figure 7 – Existing bridge outlet cross-section as modeled to account for sewer main obstruction

B.3. Post-Project Bridge Geometry

Figure 8 shows a cross-section of the bridge inlet as modeled with the geopolymer liner applied and portions of the concrete footings removed. The existing waterway opening area at the inlet is approximately 210 square feet (see Figure 4). The geopolymer liner would occupy approximately 11 square feet and the concrete footing removal would add about 11 square feet, resulting in no change to the overall waterway opening area at the inlet.

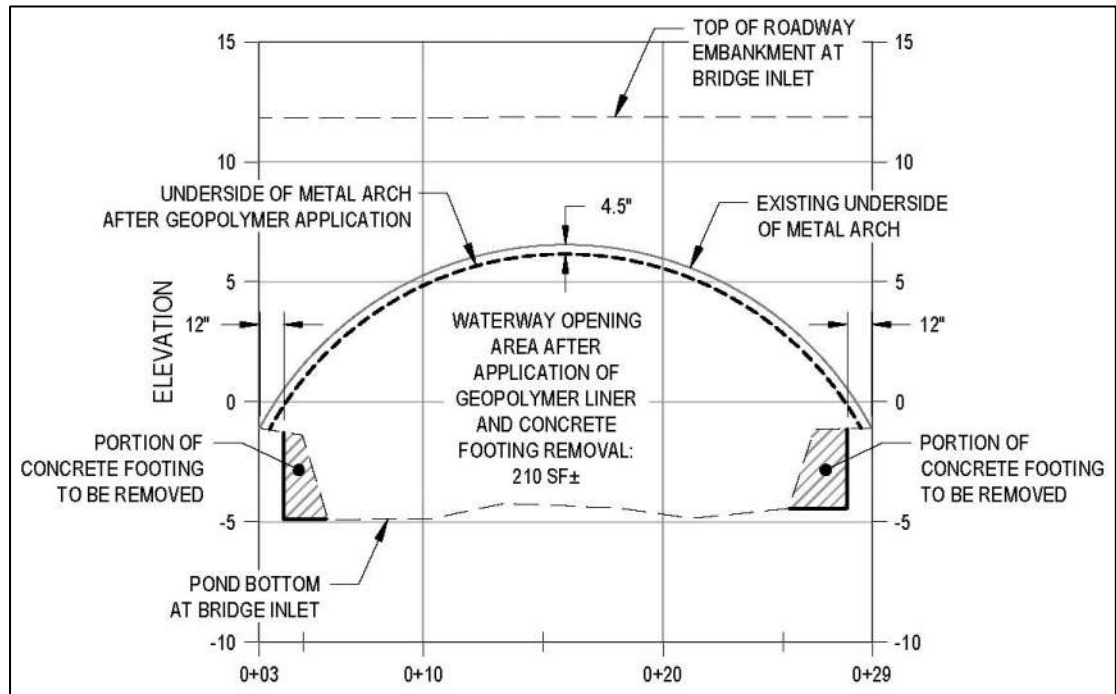

Figure 8 – Post-project bridge inlet cross-section

The waterway opening at the bridge outlet was reduced by an area equal to the sum of the areas obstructed by the geopolymer liner and sanitary sewer main (45 sf) less the area added by removing portions of the concrete footings (15 sf). Figure 9 shows the bridge outlet section defined in the hydraulic models to account for these obstructions and additions which increase the modeled waterway opening area at the bridge outlet from 205 square feet (see Figure 7) to about 210 square feet.

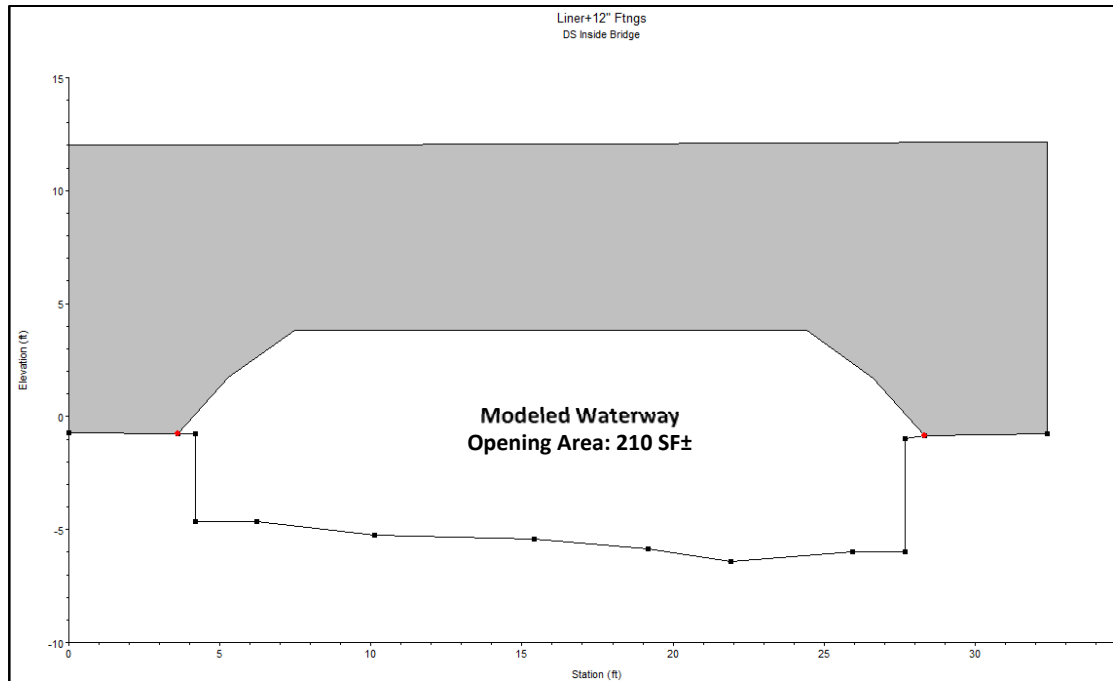

Figure 9 – Post-project bridge outlet cross-section as modeled to account for the areas obstructed by the geopolymer liner and sewer main and the area added by removing portions of the concrete footings

Details for the geopolymer liner at the interface of the metal arch and concrete footings are still being developed and as a result there may be some minor differences between the final proposed waterway opening geometries and those shown in Figures 8 and 9; however, if these result in a diminution of the modeled opening areas, additional concrete footing removal will be incorporated into the details such that the final proposed waterway opening geometries will have the same cross-sectional areas as the modeled waterway openings and the results of these analyses will still be valid.

B.4. Roughness

2017 aerial photography and the "Impervious Surfaces in the Coastal Watershed of NH and Maine, High Resolution – 2015" and "Land Use 2015 - Southeastern New Hampshire" GIS layers downloaded from NHGRANIT were used to map land cover in the hydraulic study area via the creation of GIS land cover polygons. Manning's n surface roughness coefficients were then assigned to each land cover type for use in the hydraulic modeling. Figure 10 shows the land cover mapping and Table 1 lists the roughness coefficients assigned to the land cover classifications. A full-size copy of the land cover map is included in Appendix 1.

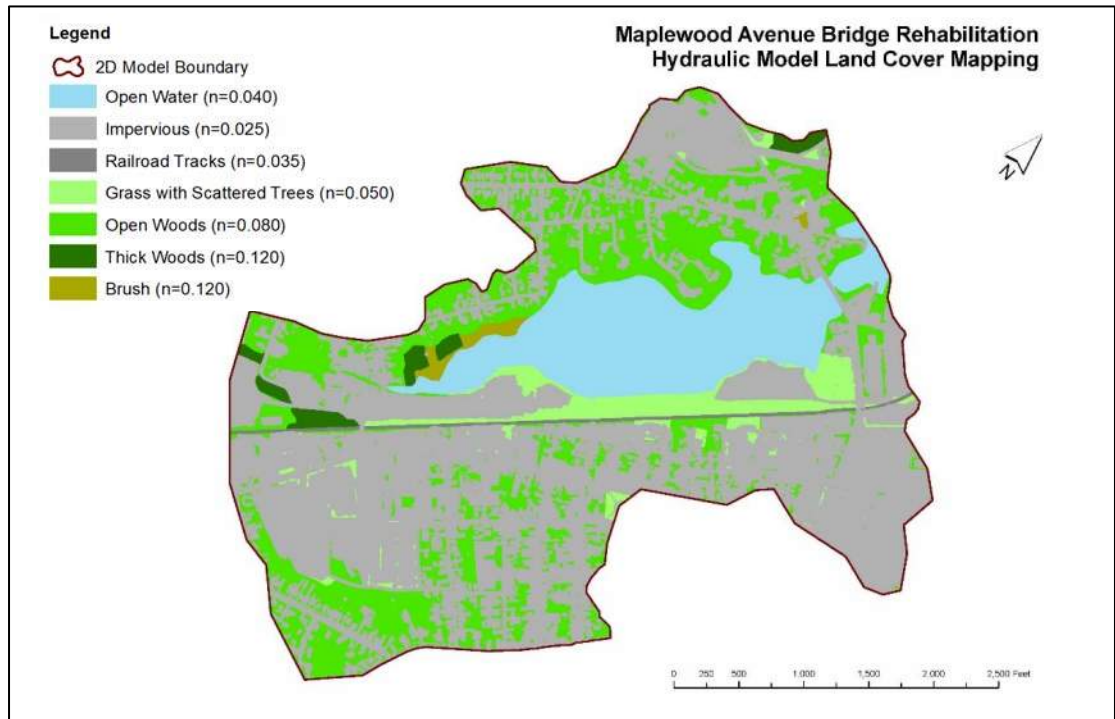

Figure 10 – Land cover mapping

Table 1 – Manning’s n roughness coefficients

Land Cover Classification	Manning’s n Roughness Coefficient
Open Water	0.040
Impervious Surface	0.025
Railroad Tracks	0.035
Grass with Scattered Trees	0.050
Open Woods	0.080
Thick Woods	0.120
Brush	0.120

Figure 11 shows the hydraulic study area (i.e., 2D model boundary) overlaid on the 2017 aerial photography.

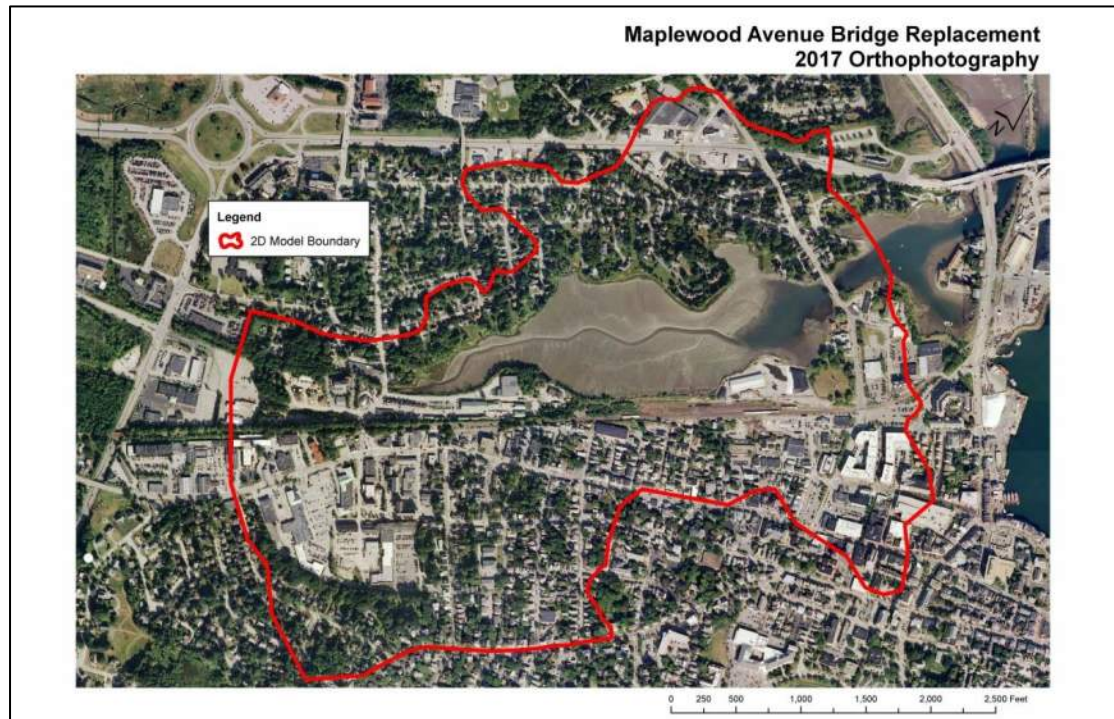

Figure 11 – Hydraulic study area boundary overlaid on 2017 aerial photography

B.5. Boundary Conditions

External boundary conditions were defined at the upstream (south) and downstream (north) limits of the hydraulic study area in each model. These include flow hydrographs at the upstream end of the study area, which represent freshwater inflow to North Mill Pond, and stage hydrographs at the downstream end of the study area to simulate tide fluctuations.

Since Env-Wt 903.05(f) only requires an assessment of project's impact on the tidal hydrograph, the freshwater inflow hydrograph only reflects base flow conditions for Hodgson Brook, which are estimated to be a constant discharge of 2 cfs, which is the approximate flow that is equaled or exceeded 60% of the time predicted by the flow duration regression equations in the web-based USGS StreamStats program² (see Appendix 1).

Data from the NOAA Seavey Island tide station (#8419870) were used to develop stage hydrographs for the downstream boundary. The tide station is located at the Portsmouth Naval Shipyard about 1.2 miles due east of the bridge and has operated intermittently between 1926 and present with a cumulative record of approximately 58 years.

Doucet Survey, LLC completed a tidal study in May and June 2022 to relate tide stages on the north side of Maplewood Avenue (i.e., the ocean side) to tide stages measured at the Seavey Island tide station. This involved surveying high and low water elevations at the bridge on three separate occasions, comparing these to the high and low water elevations measured at the tide station, and using the data to calculate tide datums on the north side of the bridge.

² Flynn, R.H. and Tasker, G.D., 2002, Development of Regression Equations to Estimate Flow Durations and Low-Flow-Frequency Statistics in New Hampshire Streams: U.S. Geological Survey Scientific Investigations Report 02-4298, 66 p. (<http://pubs.water.usgs.gov/wrir02-4298>)

Table 2 summarizes the calculated tidal datums. A summary table from the Doucet tidal study is also included in Appendix 1.

Table 2 – Tide Datums from Doucet Survey Tidal Study

Datum	Description	Maplewood Ave. Bridge (North Side)	Seavey Island Tide Station (#8419870)
HAT	Highest Astronomical Tide	5.6 ft	5.87 ft
MHHW	Mean Higher-High Water	4.0 ft	4.18 ft
MHW	Mean High Water	3.6 ft	3.76 ft
MTL	Mean Tide Level	-0.3 ft	-0.32 ft
MLW	Mean Low Water	-4.2 ft	-4.39 ft
MLLW	Mean Lower-Low Water	-4.5 ft	-4.71 ft
NAVD88	North American Vertical Datum of 1988	0.0 ft	0.00 ft

Tide stage hydrographs used for the downstream boundaries were estimated using water levels measured at the Seavey Island station during tide cycles with crests and troughs equal to MHHW and MLLW, respectively. These occurred most recently at 4:24 AM on July 16, 2021 (higher-high water 4.18 ft) and 6:48 PM on October 26, 2022 (lower-low water -4.71 ft).

Six-minute water level data for 24-hour periods centered on the MHHW and MLLW measurements at the tide station were downloaded from the NOAA website. Per the Doucet tidal study, MHHW on the north side of the bridge is approximately 4.3% lower than MHHW at the tide station and MLLW on the north side of the bridge is approximately 4.5% higher than MLLW at the tide station. The water levels measured at the tide station were lowered and raised by these percentages to generate tide stage hydrographs simulating MHHW and MLLW on the north side of the bridge which were used as the downstream boundaries in the models. Figures 12 and 13 show the tide stage hydrographs simulating MHHW and MLLW at the downstream model boundary.

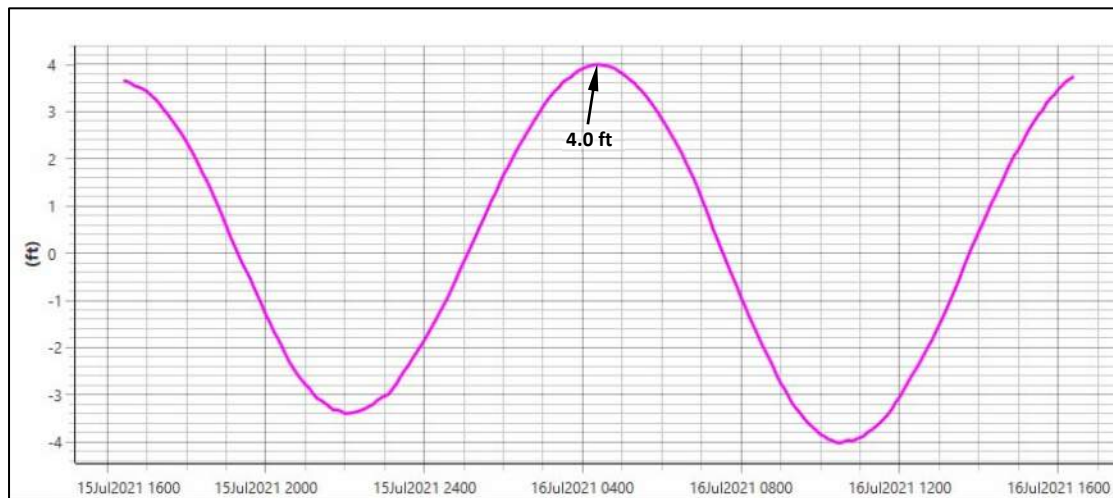

Figure 12 – Tide stage hydrograph simulating MHHW at the downstream model boundary

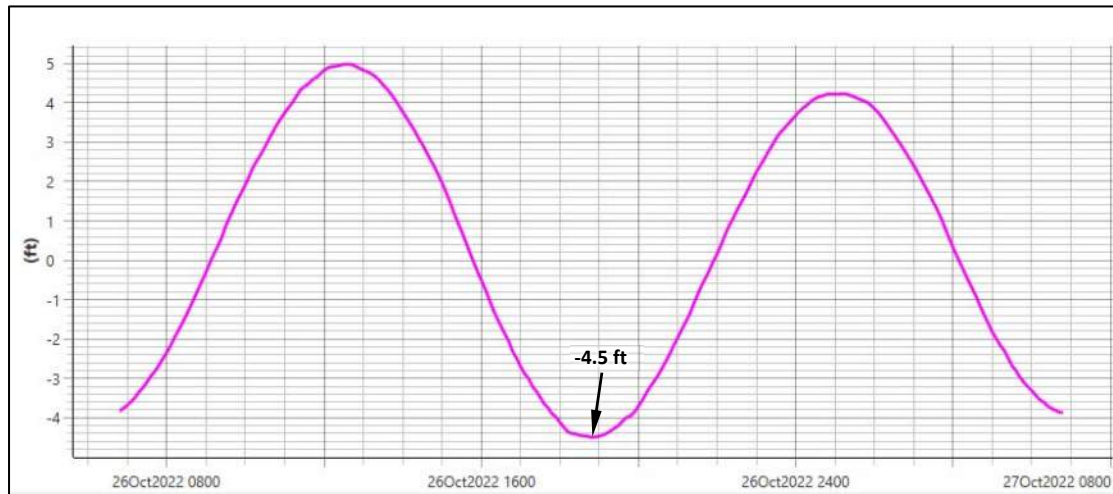

Figure 13 – Tide stage hydrograph simulating MLLW at the downstream model boundary

B.6. Additional Modeling Parameters

All models were run with the full momentum SWE-ELM equation set (i.e., Shallow Water Equations, Eulerian-Lagrangian Method) which is appropriate for tidally-influenced conditions as it is capable of modeling the propagation of dynamic tide cycle waves.

The HEC-RAS program was allowed to adjust the computational time step as needed to produce stable model runs with Courant numbers of about one or less to ensure that flow was not propagating through more than one cell at each time step.

Bridge hydraulics were calculated with the energy-based standard step method for low flow conditions (i.e., open channel flow where the water surface is below the highest point of the bridge low chord) and pressure flow (orifice equations) for high flow conditions when the bridge is submerged. The energy-based method was selected as the low flow computational method because there are no piers and this method accounts for friction losses, changes in geometry through the bridge, and losses due to flow transitions and turbulence. Contraction and expansion coefficients of 0.3 and 0.5, respectively, were used in the energy head loss equation. The pressure flow method was used as the high flow computational method because the bridge deck and roadway are significant flow obstructions which create backwater and result in the bridge opening acting like a pressurized orifice when it is submerged.

B.7. Analysis Results – MHHW

Both the pre- and post-project MHHW models indicate that the peak stage in North Mill Pond south of the bridge is only slightly lower (<0.01 ft) than on the north side of the bridge. Figure 14 shows the inundation area at the MHHW tide stage crest and the centroid of the portion of North Mill Pond south of Maplewood Avenue, which has been selected as a representative location for comparing the pre- and post-project MHHW tidal hydrographs.

Figure 15 shows the pre- and post-project MHHW tide stage hydrographs calculated at the centroid. The analysis shows little change to the tide crest and more substantial changes to the tide trough, which is discussed in Section B.8. Figure 16 shows a zoomed in view of the pre- and post-project stage hydrographs at the tide crest so that the minor changes at the upper end of the tide range projected to result from the bridge rehabilitation project can be seen. As compared to pre-project conditions, the analysis shows no change to the MHHW high water level or duration of the tide crest and that the time to reach the peak stage would be delayed by 1 minute.

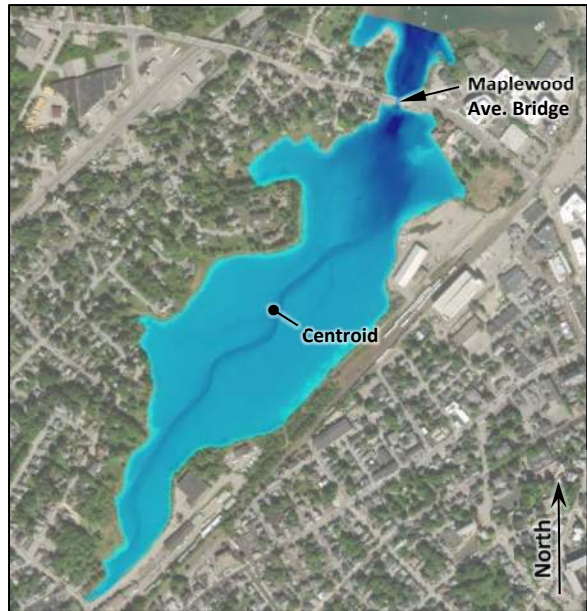

Figure 14 – Inundation area at the MHHW tide stage crest and centroid of the portion of North Mill Pond south of Maplewood Avenue

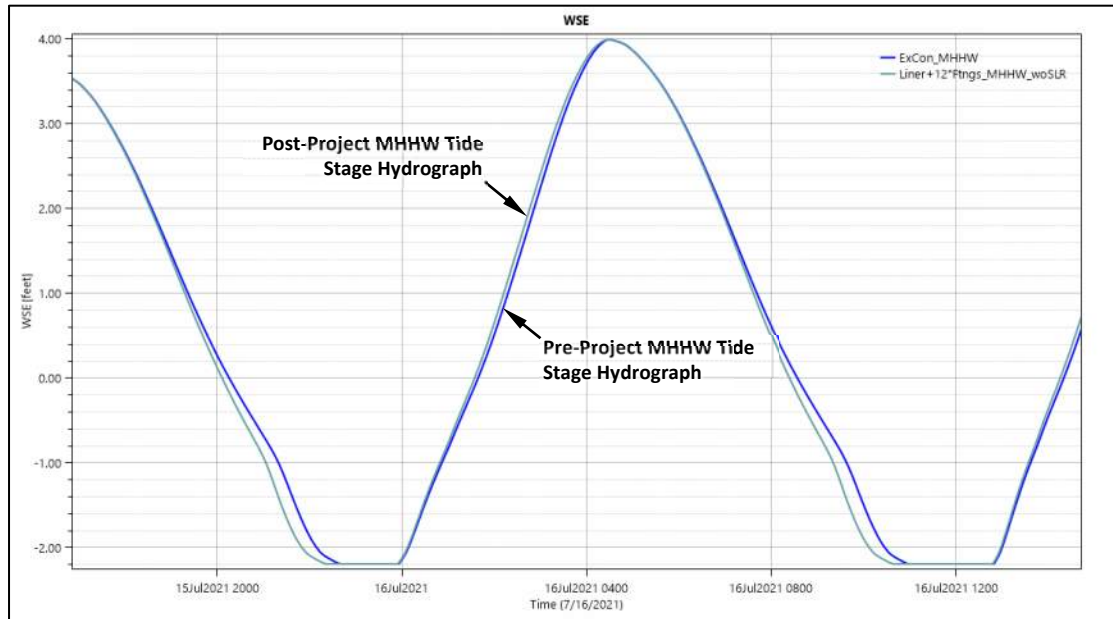

Figure 15 – Pre- and post-project MHHW tide stage hydrographs calculated at the centroid of the portion of North Mill Pond south of Maplewood Avenue

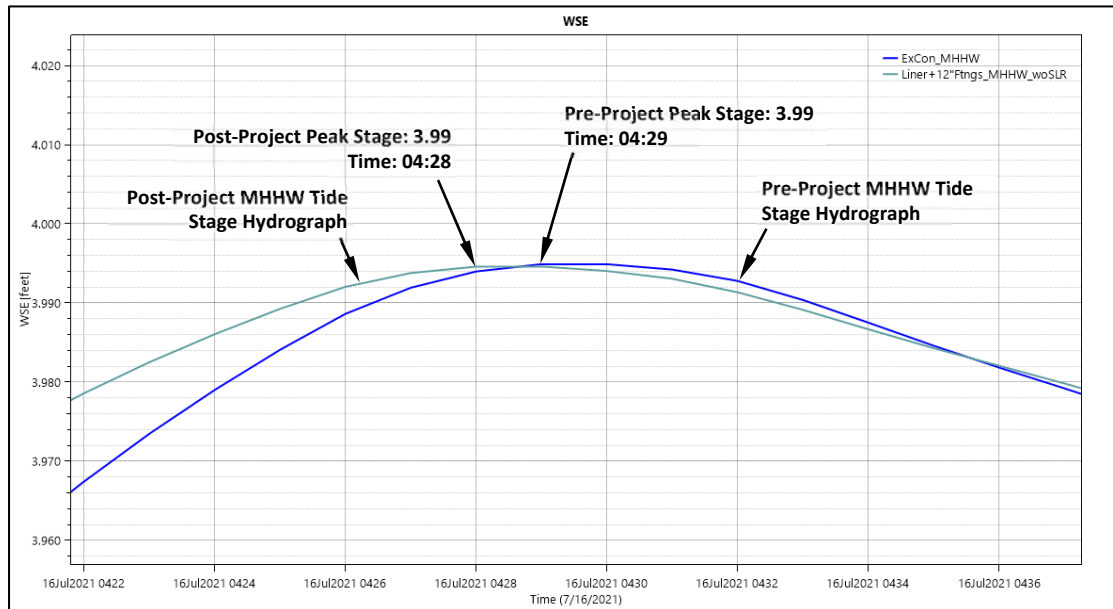

Figure 16 – Crest of the pre- and post-project MHHW tide stage hydrographs calculated at the centroid of the portion of North Mill Pond south of Maplewood Avenue for MHHW

B.8. Analysis Results – MLLW

The pre- and post-project MLLW models indicate that: (1) the project would lower the low water level in the portion of North Mill Pond south of the bridge by 0.10 feet and (2) the lowest stages in North Mill Pond south of the bridge for pre- and post-project conditions are about 1.2 and 1.1 feet higher, respectively, than the lowest water level on the north side of the bridge. Figure 17 shows the pre- and post-project inundation areas at the MLLW tide stage trough in the vicinity of Maplewood Avenue. Blue shading represents the post-project inundation area at MLLW and yellow shading along the periphery of the blue shading indicates the additional areas inundated at MLLW under pre-project conditions. The pre-project MLLW inundation area of the main waterbody south of Maplewood Avenue (i.e., not including isolated areas of ponded water remaining after the tide recedes) is approximately 264,300 square feet (6.067 acres) and the post-project MLLW inundation area of south of the road is about 256,400 square feet (5.886 acres). This is a reduction of approximately 7,900 square feet (0.181 acres) or about 3.0%. Note that at the time steps depicted in

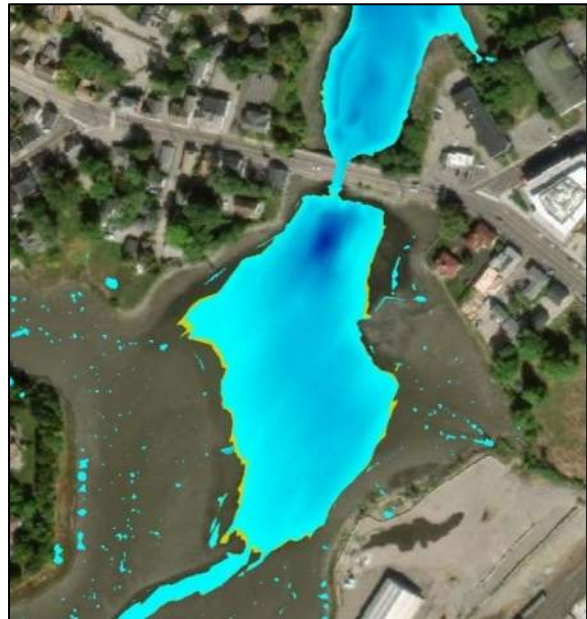

Figure 17 – Inundated areas at the MLLW tide stage trough with blue shading representing the post-project inundation area and yellow shading indicating the additional areas inundated under pre-project conditions

Figure 17, the water level south of Maplewood Avenue has just reached its lowest level, whereas the tide has been rising on the north side of the road for nearly 1½ hours.

The differences between the water levels on either side of Maplewood Avenue are due to two significant factors: (1) the flow restriction created by the crossing which prevents the pond on the south side of the road from draining as fast as the tide recedes on the north side and (2) what appears to be bedrock grade control on the pond bottom just upstream from the bridge (see Figure 18). The lowest elevation of the grade control was measured at about elevation -3.5 feet (NAVD88). The portion of the pond south of the grade control cannot drain below this elevation even when the water level on the north side of Maplewood Avenue is significantly lower.



Figure 18 – View south from Maplewood Avenue at the grade control feature just upstream from the bridge inlet (09-23-20)

Figure 19 shows the pre- and post-project MLLW tide stage hydrographs calculated at a point about 250 feet south of the bridge inlet where the water depth at MLLW is about four feet and Figure 20 shows a detailed view of the hydrographs at the tide cycle trough representing MLLW. The analysis shows that the project would lower the low water level at the tide stage trough by 0.10 feet and reduce the time to reach the low water level by 3 minutes.

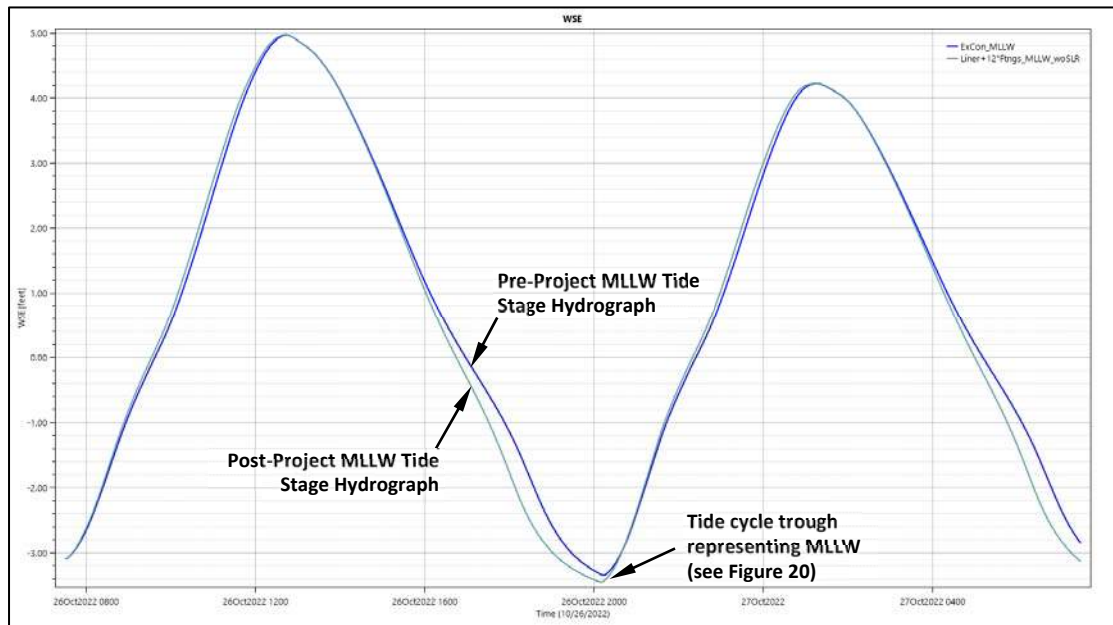

Figure 19 – Pre- and post-project MLLW tide stage hydrographs calculated in North Mill Pond south of Maplewood Avenue

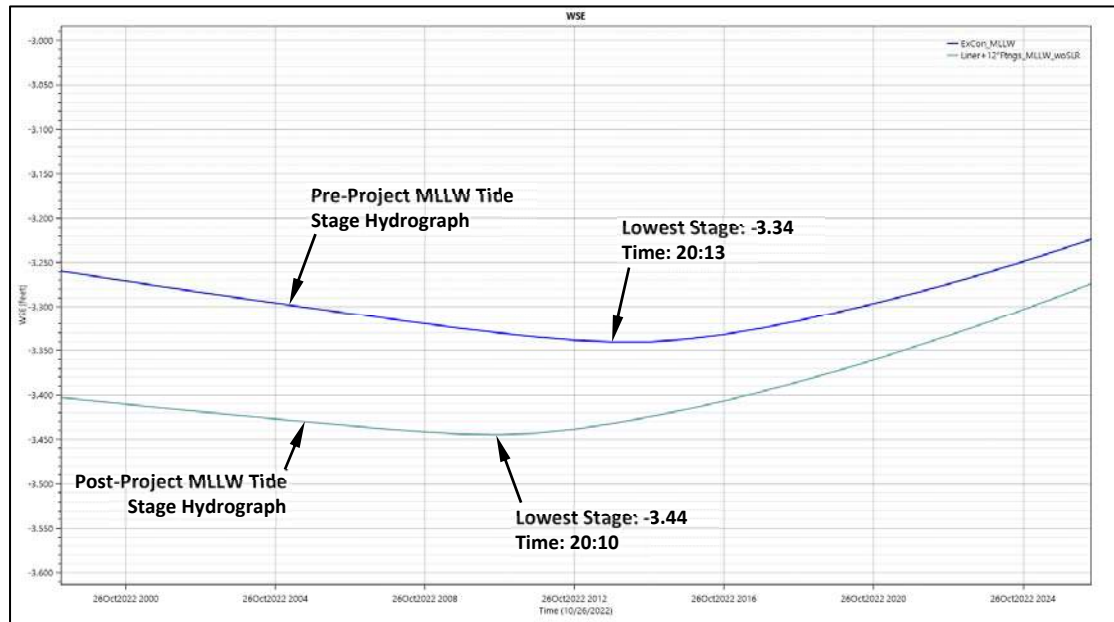

Figure 20 – Troughs of the pre- and post-project MLLW tide stage hydrographs calculated in the portion of North Mill Pond south of Maplewood Avenue

The lower water level, and faster time to reach that level, are explained by the proposed changes to the waterway opening. As compared to the pre-project bridge opening, the post-project opening will be smaller at the top due to the geopolymer liner, but larger at the bottom due to the footing removal. As a result, the bridge will have greater capacity when water levels are low and the portion of the pond on the south side of the road will drain faster as the tide cycle trough approaches. The faster drain time is important as it allows the water level south of the road to reach a lower stage before the water level on the north side of the road rises and the flow reverses.

B.9. Tidal Resource Impact

Because the bridge only restricts flow into and out of the portion of North Mill Pond on the south side of Maplewood Avenue, the project will not affect the tidal hydrograph in the portion of North Mill Pond on the north side of Maplewood Avenue.

Concerning the portion of North Mill Pond south of Maplewood Avenue, the project will not alter the MHHW high water level and changes to the MLLW low water level, inundation area, and water depths are not considered significant enough to adversely affect the tidal resource, particularly in light of the natural water level variability this area experiences due to astronomical tides and local wind and weather patterns.

C. Env-Wt 904.07(d)

Env-Wt 904.07(d) requires that “new, repaired, rehabilitated, or replaced tier 4 stream crossing shall be designed: (1) Based on a hydraulic analysis that accounts for daily fluctuating tides, bidirectional flows, tidal inundation, and coastal storm surge; (2) To prevent creating a restriction on tidal flows; and (3) To account for tidal channel morphology and potential impacts due to sea-level rise.”

The four HEC-RAS 2D flow models described in Section B simulate pre- and post-project conditions under normal astronomical tide conditions (MHHW and MLLW) without sea-level rise (SLR). Twelve additional HEC-RAS 2D flow models were created to analyze the effects of the proposed bridge rehabilitation work under various storm and SLR scenarios. These include:

- MHHW and MLLW with SLR under pre- and post-project conditions;
- 50- and 100-year storms without SLR under pre- and post-project conditions; and
- 50- and 100-year storms with SLR under pre- and post-project conditions.

These models account for fluctuating tides, bidirectional flow, tidal inundation, storm surge, and SLR as required by Env-Wt 904.07(d). All of these models use the same geometry data (including pre- and post-project bridge geometries), roughness, and additional modeling parameters described in Section B. However, each model uses different boundary conditions to simulate the various tide cycle, storm surge, freshwater inflow, and SLR conditions.

The recommended SLR estimate published in Step 3 Table A of NHCFR STAP (2020)³ for a project with a high tolerance for flood risk and a year 2040 timeframe, which is the timeframe that most closely matches that of the bridge rehabilitation project design life, is 1.0 ft (see Figure 21). For the models which account for SLR, this estimate was used to adjust the present-day tide stage hydrographs to simulate sea-level conditions at the end of the rehabilitated bridge service life. Additional information concerning the projects’ flood risk tolerance and timeframe can be found in Section D.3.

STEP 3 TABLE A. RECOMMENDED DECADEAL RSLR ESTIMATES (IN FEET ABOVE 2000 LEVELS) BASED ON RCP 4.5, PROJECT TIMEFRAME, AND TOLERANCE FOR FLOOD RISK.

TIMEFRAME	HIGH TOLERANCE FOR FLOOD RISK	MEDIUM TOLERANCE FOR FLOOD RISK	LOW TOLERANCE FOR FLOOD RISK	VERY LOW TOLERANCE FOR FLOOD RISK
	Plan for the following RSLR estimate (ft)* compared to sea level in the year 2000			
	Lower magnitude, Higher probability	←————→		Higher magnitude, Lower probability
2030	0.7	0.9	1.0	1.1
2040	1.0	1.2	1.5	1.6
2050	1.3	1.6	2.0	2.3
2060	1.6	2.1	2.6	3.0
2070	2.0	2.5	3.3	3.7
2080	2.3	3.0	3.9	4.5
2090	2.6	3.4	4.6	5.3
2100	2.9	3.8	5.3	6.2
2110	3.3	4.4	6.1	7.3
2120	3.6	4.9	7.0	8.3
2130	3.9	5.4	7.9	9.3
2140	4.3	5.9	8.9	10.5
2150	4.6	6.4	9.9	11.7

Figure 21 – Step 3 Table A from NHCFR STAP (2020)

³ NH Coastal Flood Risk Science and Technical Advisory Panel (2020). New Hampshire Coastal Flood Risk Summary, Part II: Guidance for Using Scientific Projections. Report published by the University of New Hampshire, Durham, NH.

The 50- and 100-year storm models assume that a tidal storm surge and a freshwater flood on Hodgson Brook occur simultaneously. These are believed to be conservative, but realistic, scenarios as coastal weather systems which generate storm surge also have the potential to produce extreme rainfall. In each storm model the recurrence interval of the tidal storm surge and the freshwater flood are assumed to be equal. For example, the 50-year storm models assume that a 50-year tidal storm surge and a 50-year freshwater flood occur simultaneously. Furthermore, in these models the tide stage hydrographs and the freshwater inflow hydrographs are assumed to peak concurrently so as to simulate near worst-case scenarios wherein the peak inland runoff enters North Mill Pond at the same time the storm tide reaches its maximum level.

Independent hydrology studies to estimate the rate and volume of rainfall runoff into North Mill Pond from various storms have been completed for the bridge rehabilitation project and the drainage outfall project. The hydrology study for the bridge rehabilitation project was performed by Headwaters Consulting and produced estimates of the 50- and 100-year rainfall runoff hydrographs for the entire watershed of North Mill Pond upstream from the bridge which encompasses the watershed of the drainage outfall. The hydrologic analysis for the drainage outfall project was done by Underwood Engineers and included only the watershed of the drainage outfall. For both studies the SCS unit hydrograph method was used with the HydroCAD computer program to estimate the freshwater inflow hydrographs. A complete copy of the Headwaters Consulting hydrology study is included in Appendix 2. Output from the HydroCAD models prepared by Underwood Engineers can be found in Appendices 3 and 4.

The watershed area of the drainage outfall at North Mill Pond (37 acres) represents about 1.4% of the overall watershed area of the pond at Maplewood Avenue (2,628 acres). The drainage outfall project proposes improvements to the stormwater collection system which would increase its maximum flow capacity, but it will not expand the watershed area, add impervious surfaces, or otherwise increase the overall stormwater runoff volume, except that it is designed to accommodate future separation of existing roof drains that are currently connected to the sanitary sewer system but have been incorporated into the outfall's drainage calculations. The pre- and post-project HydroCAD models for the drainage outfall project show no change to the watershed area, runoff curve numbers (CN), or total runoff volume (see Appendices 3 and 4). [Note that the HydroCAD outputs show a minor difference between the pre- and post-project total runoff volumes; however, this is because the two models used different time spans. The pre- and post-project runoff volumes would be identical if the same time span had been used.]

A comparison between the results of the bridge rehabilitation and drainage outfall hydrology studies shows that under both pre- and post-project conditions: (1) peak runoff at the bridge occurs about 7.3 hours after peak runoff from the drainage outfall enters the pond and (2) nearly the entire runoff volume from the drainage outfall watershed enters North Mill Pond by the time peak runoff from the overall watershed occurs. This is due to the small size of the drainage outfall watershed, the absence of any significant floodwater storage areas, and its close proximity to the pond. By contrast, runoff from the hydraulically most distant point of the overall watershed, located at the Portsmouth International Airport, must travel approximately 4.4 miles to the bridge.

Therefore, because the drainage outfall project is not expected to significantly increase the total runoff volume or alter the timing of runoff to North Mill Pond, it is not projected to change the peak flows, runoff volumes, or flow hydrographs calculated for the entire watershed draining to the bridge. Consequently, the same 50- and 100-year flow hydrographs calculated under the

bridge rehabilitation project hydrology study (see Appendix 2) have been used in both the pre- and post-project HEC-RAS 2D flow models which simulate storm conditions.

Detailed descriptions of the boundary conditions used in the models and the analysis results are provided in the following sections.

C.1. Pre- and Post-Project MHHW Models without SLR

These are the same models described in Section B which use the pre- and post-project bridge geometries and the MHHW tidal hydrograph. Additional results from these models are presented in this section to meet the requirements of Env-Wt 904.07(d)(2) relative to tidal flow restriction.

Figures 22 and 23 show the MHHW stage and flow hydrographs at the bridge calculated for pre- and post-project conditions, respectively. The headwater stage is the water level at the bridge inlet on the south side of Maplewood Avenue and the tailwater stage is the water level at the bridge outlet on the north side of the road. Note that when the headwater stage is greater than the tailwater stage flow is from south to north and the flow values are positive. When the tailwater stage is higher than the headwater stage flow is from north to south and the flow values are negative.

The maximum flow through the bridge from south to north during the MHHW tide cycle is 721 cfs for pre-project conditions and 762 cfs for post-project conditions, an increase of 41 cfs, or approximately 5.7%. The maximum flow through the bridge from north to south during the MHHW tide cycle is 960 cfs for pre-project conditions and 946 cfs for post-project conditions, a reduction of 14 cfs, or approximately 1.5%.

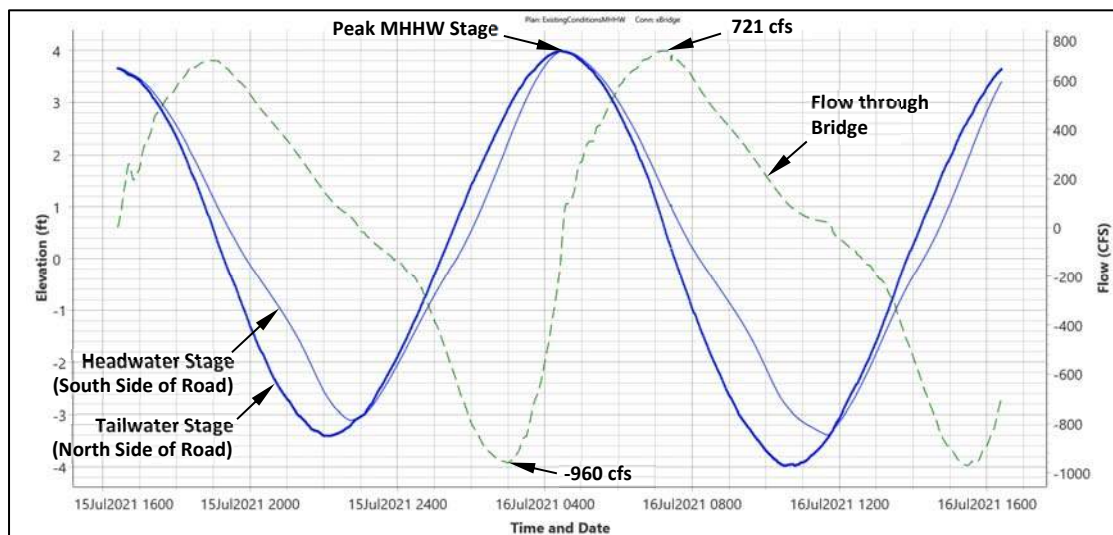

Figure 22 – Pre-project stage and flow hydrographs calculated at the bridge for MHHW without SLR

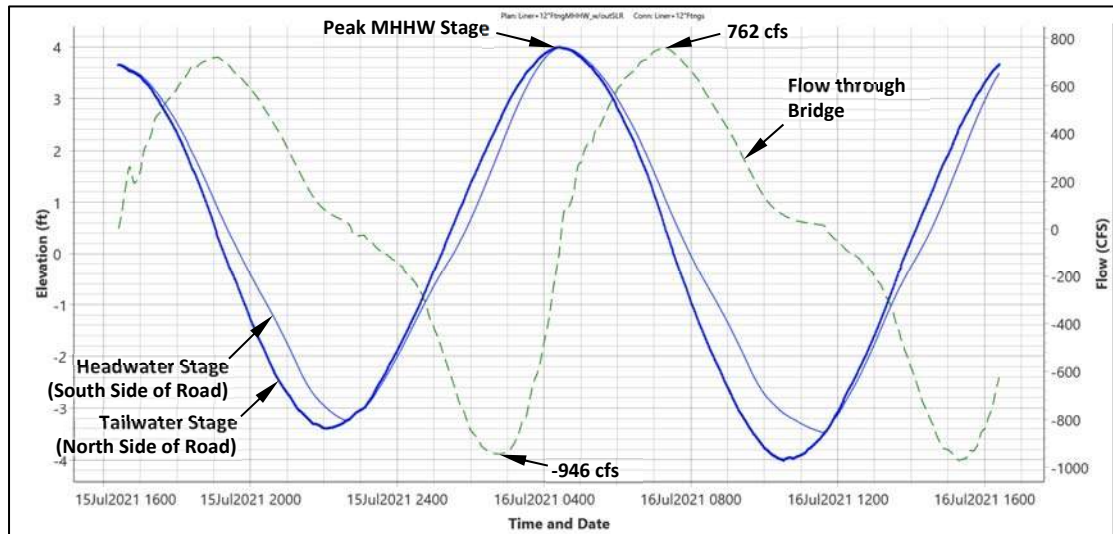

Figure 23 – Post-project stage and flow hydrographs calculated at the bridge for MHHW without SLR

The proposed bridge rehabilitation would result in increased peak flow through the bridge from south to north for the MHHW event, indicating that the project will not restrict tidal flows during the outgoing tide and would in fact reduce the existing flow restriction. The small reduction in peak flows from north to south is explained by the faster rate that the portion of the pond south of Maplewood Avenue would fill during the incoming tide (see Figure 15) which decreases the water level differential on either side of the bridge and reduces the maximum flow rate through it. This also indicates that the project will not restrict tidal flows, even though this decreased differential results in a slightly lower peak flow.

C.2. Pre- and Post-Project MLLW Models without SLR

These are the same models described in Section B which use the pre- and post-project bridge geometries and the MLLW tidal hydrograph. Additional results from these models are presented in this section to meet the requirements of Env-Wt 904.07(d)(2) relative to tidal flow restriction.

Figures 24 and 25 show the MLLW stage and flow hydrographs at the bridge calculated for pre- and post-project conditions, respectively. The maximum flow through the bridge from south to north during the MLLW tide cycle is 858 cfs for pre-project conditions and 895 cfs for post-project conditions, an increase of 37 cfs, or approximately 4.3%. The maximum flow through the bridge from north to south during the MLLW tide cycle is 1,092 cfs for pre-project conditions and 1,097 cfs for post-project conditions, an increase of 5 cfs, or approximately 0.5%.

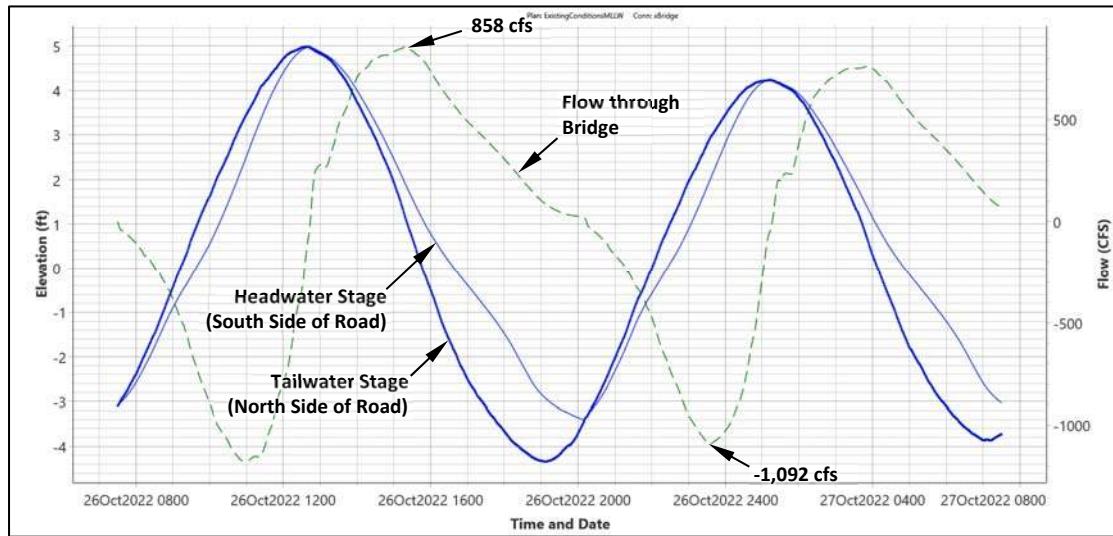

Figure 24 – Pre-project stage and flow hydrographs calculated at the bridge for MLLW without SLR

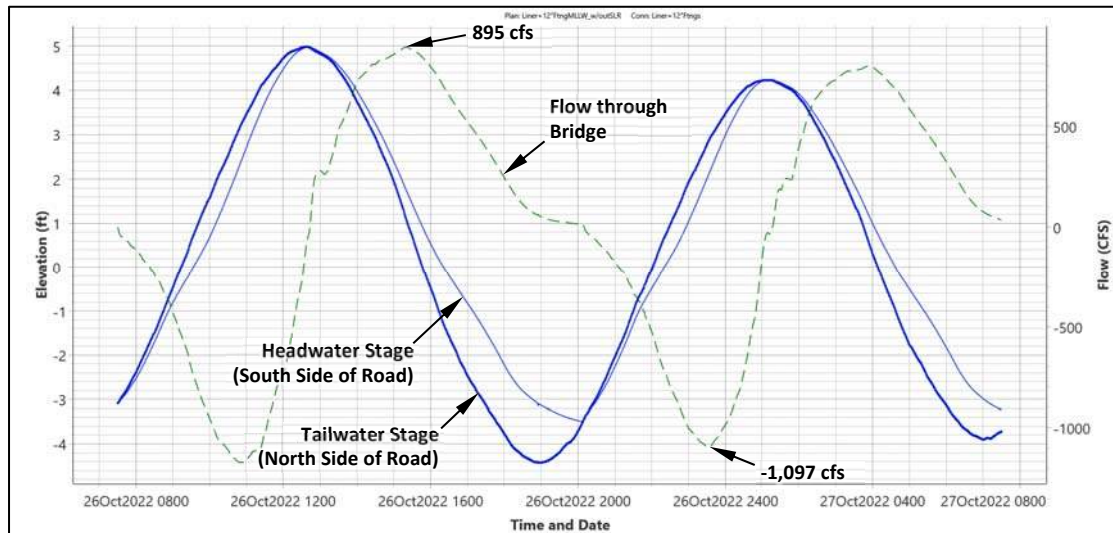

Figure 25 – Post-project stage and flow hydrographs calculated at the bridge for MLLW without SLR

The proposed bridge rehabilitation would increase flow rates through the bridge in both directions during the MLLW event; therefore, the project will not restrict tidal flows for this event under present-day sea-level conditions and would in fact reduce the existing flow restriction.

C.3. Pre- and Post-Project MHHW Models with SLR

The water level at each time step of the present-day MHHW tide stage hydrograph shown in Figure 12 was raised by 1.0 ft to develop an estimate of the MHHW tide stage hydrograph with SLR during the bridge rehabilitation project design life. This results in a MHHW stage of 5.0 ft (NAVD88) on the north side of the bridge. The estimated MHHW tide stage hydrograph with SLR shown in Figure 26 was used as the downstream boundary in the models. The same flow hydrograph used in the MHHW model without SLR, which assumes a constant base flow of 2 cfs in Hodgson Brook, was used as the upstream boundary in the models.

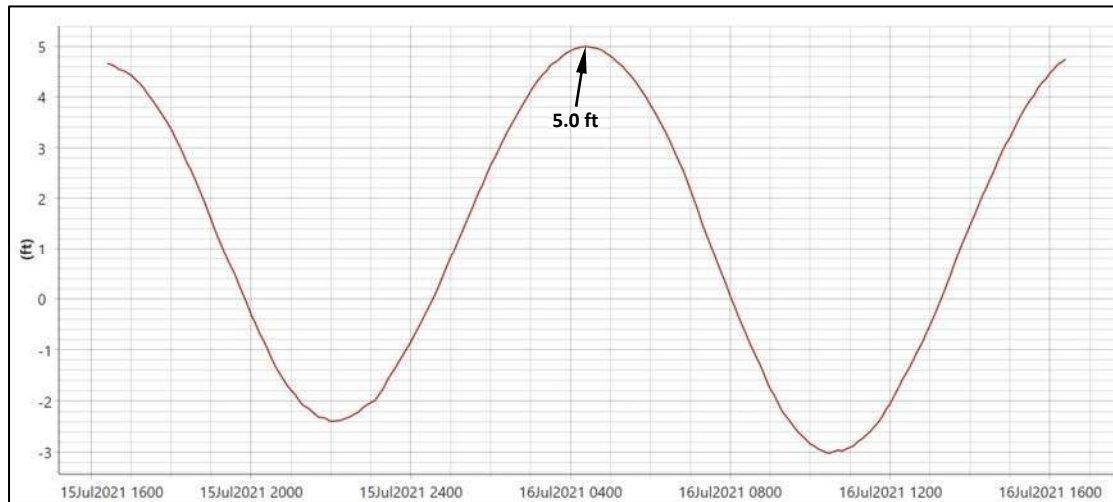

Figure 26 – Tide stage hydrograph simulating MHHW with 1.0' SLR at the downstream model boundary

Both the pre- and post-project MHHW models with SLR indicate that the peak stage in North Mill Pond south of the bridge would be only slightly lower (~0.01 ft) than on the north side of the bridge. Figure 27 shows the inundation area at the MHHW tide stage crest with 1.0 ft SLR for both pre- and post-project conditions.



Figure 27 – Inundation area at the MHHW tide stage crest with 1.0 ft SLR for both pre- and post-project conditions

Figure 28 shows the pre- and post-project MHHW tide stage hydrographs with 1.0 ft SLR calculated at the centroid of the portion of North Mill Pond south of Maplewood Avenue. The analysis shows very little difference in maximum water levels or the timing of the tide stage crest between pre- and post-project conditions. Consequently, the pre- and post-project stage hydrographs near the tide stage crest shown in Figure 28 cannot be distinguished from each other. Therefore, Figure 29 shows a zoomed in view of the hydrographs at the crest stage representing MHHW with 1.0 ft SLR so that the minor changes to the tidal hydrograph resulting from the project can be seen. As compared to pre-project conditions, the analysis shows that the peak stage would increase by less than 0.002 ft and the time to reach the peak stage would be reduced by 1 minute.

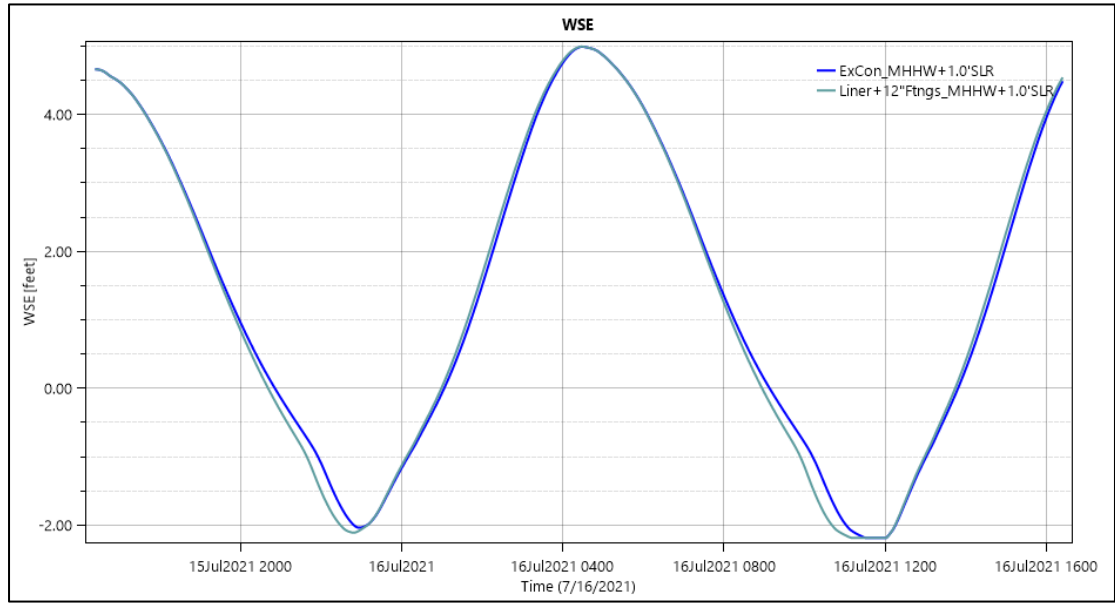

Figure 28 – Pre- and post-project MHHW tide stage hydrographs with 1.0 ft SLR calculated at the centroid of the portion of North Mill Pond south of Maplewood Avenue

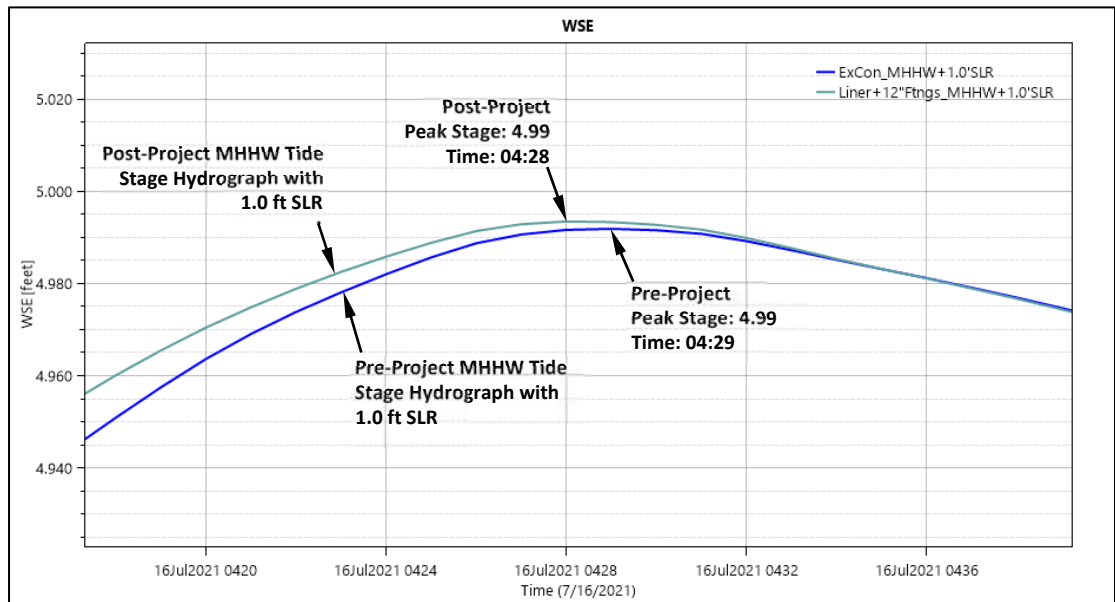

Figure 29 – Crest of the pre- and post-project MHHW tide stage hydrographs with 1.0 ft SLR calculated at the centroid of the portion of North Mill Pond south of Maplewood Avenue for MHHW

Figures 30 and 31 show the MHHW stage and flow hydrographs at the bridge calculated for pre- and post-project conditions with 1.0 ft SLR, respectively. The maximum flow through the bridge from south to north during the MHHW tide cycle with 1.0 ft SLR is 833 cfs for pre-project conditions and 865 cfs for post-project conditions, an increase of 32 cfs, or approximately 3.8%. The maximum flow through the bridge from north to south during the MHHW tide cycle with 1.0 ft SLR is 1,043 cfs for pre-project conditions and 1,035 cfs for post-project conditions, a reduction of 8 cfs, or approximately 0.8%.

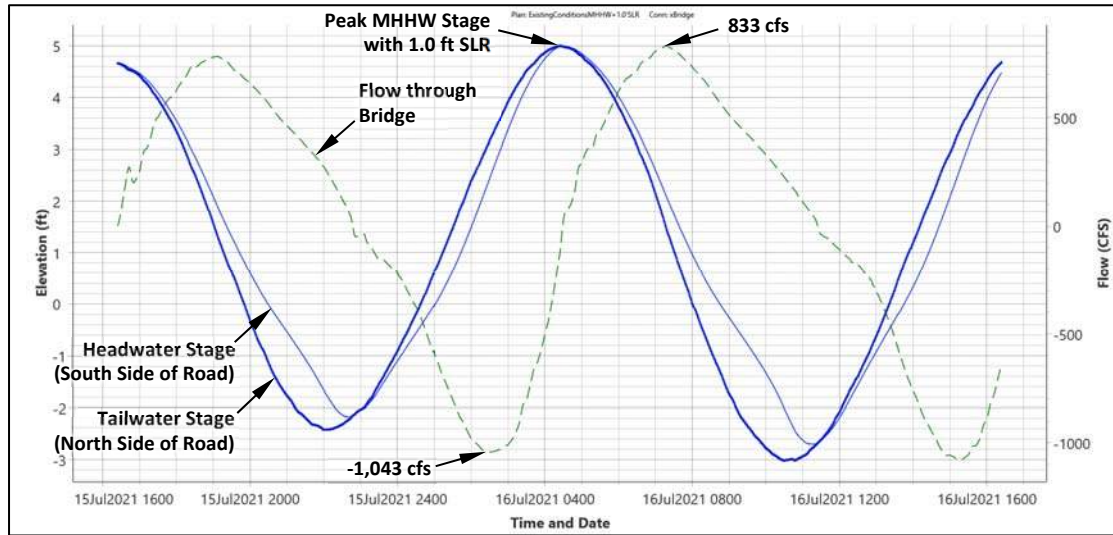

Figure 30 – Pre-project stage and flow hydrographs calculated at the bridge for MHHW with 1.0 ft SLR

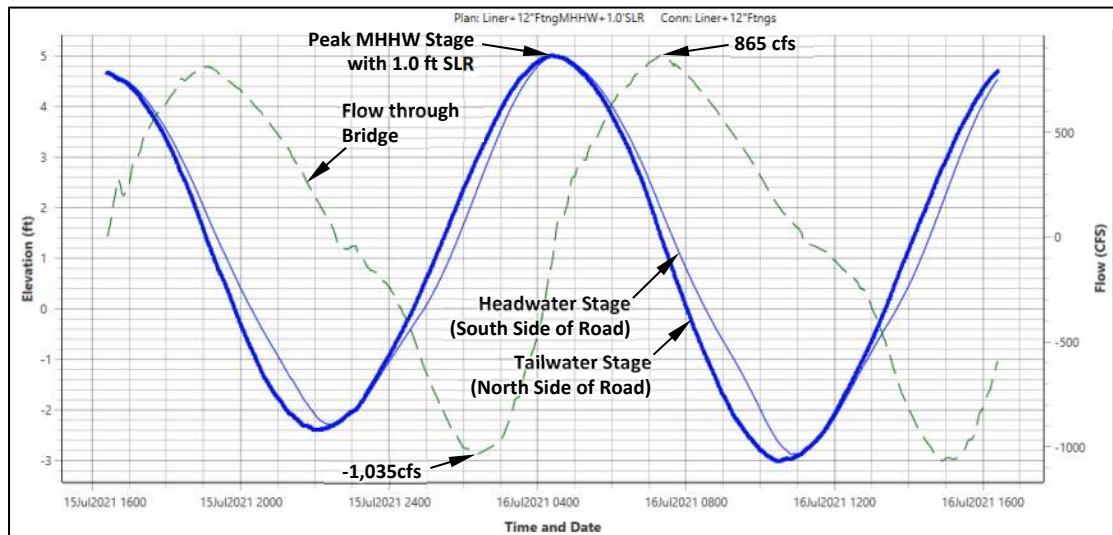

Figure 31 – Post-project stage and flow hydrographs calculated at the bridge for MHHW with 1.0 ft SLR

The models show that the proposed bridge rehabilitation would increase the peak flow rate through the bridge from south to north for the MHHW event with 1.0 ft SLR and therefore would not restrict tidal flows during the outgoing tide, but rather would reduce the existing flow restriction. The small reduction in the peak flow from north to south is due to the faster rate that the pond south of Maplewood Avenue would fill during the flood tide (see Figure 28) which increases the tailwater elevation and reduces the maximum flow rate through the bridge. This is another indication that the project will not restrict tidal flows, even though the faster fill rate and decreased tailwater result in a slightly lower peak flow during the incoming tide.

C.4. Pre- and Post-Project MLLW Models with SLR

The water level at each time step of the present-day MLLW tide stage hydrograph shown in Figure 13 was raised by 1.0 ft to develop an estimate of the MLLW tide stage hydrograph with

SLR during the bridge rehabilitation project design life (see Figure 32). This results in a MLLW stage of -3.5 feet (NAVD88) on the north side of the bridge. The estimated MLLW tide stage hydrograph with SLR shown in Figure 32 was used as the downstream boundary in the models. The same flow hydrograph used in the MLLW model without SLR, which assumes a constant base flow of 2 cfs in Hodgson Brook, was used as the upstream boundary in the models.

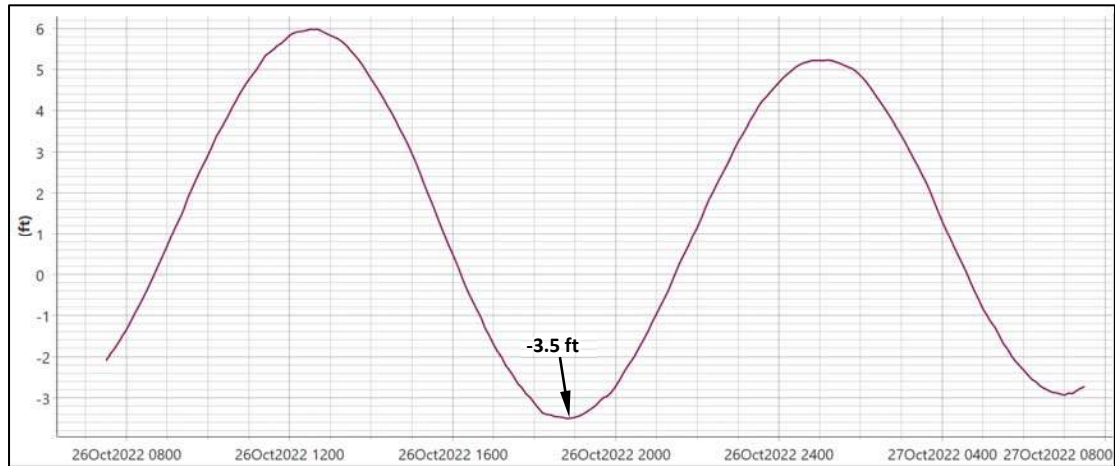

Figure 32 – Tide stage hydrograph simulating MLLW with 1.0' SLR at the downstream model boundary

The pre- and post-project MLLW models with 1.0 ft SLR indicate that the project would lower the low water level in the portion of North Mill Pond south of the bridge by 0.20 feet and reduce the difference between the low water levels on either side of the bridge from 0.65 feet to 0.45 feet. Figure 33 shows the pre- and post-project inundation areas at the MLLW tide stage trough with 1.0 ft SLR in the vicinity of Maplewood Avenue. Blue shading represents the post-project inundation area at MLLW with 1.0 ft SLR and yellow shading along the periphery of the blue shading indicates the additional areas inundated at MLLW with 1.0 ft SLR under pre-project conditions. The pre-project inundation area of the waterbody south of Maplewood Avenue is approximately 307,300 square feet (7.055 acres) and the post-project inundation area of south of the road is about 285,400 square feet (6.552 acres). This is a reduction of approximately 21,900 square feet (0.503 acres) or about 7.1%.



Figure 33 – Inundated areas at the MLLW tide stage trough with 1.0 ft SLR. Blue shading represents the post-project inundation area and yellow shading indicates the additional areas inundated under pre-project conditions

Figure 34 shows the pre- and post-project MLLW tide stage hydrographs with 1.0 ft SLR calculated at point about 250 feet south of the bridge inlet where the water depth at MLLW is approximately 4.5 feet under pre-project conditions and Figure 35 shows a detailed view of the hydrographs at the tide cycle through representing MLLW with 1.0 ft SLR. As compared

to pre-project conditions, the analysis shows that the lowest stage would decrease by 0.20 feet and the time to reach the minimum stage would be reduced by 16 minutes.

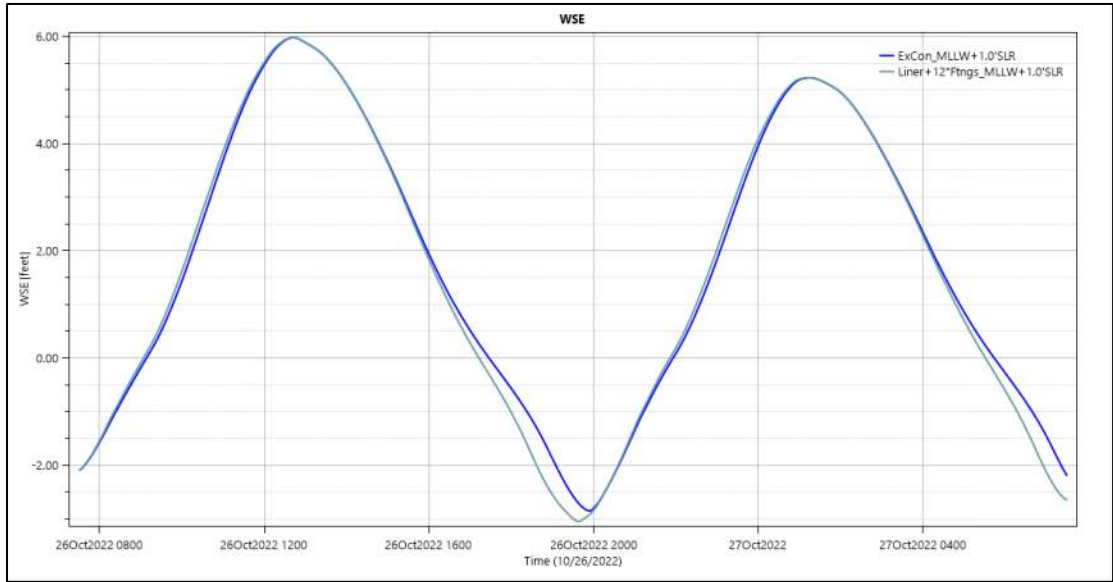

Figure 34 – Pre- and post-project MLLW tide stage hydrographs with 1.0 ft SLR calculated in North Mill Pond south of Maplewood Avenue

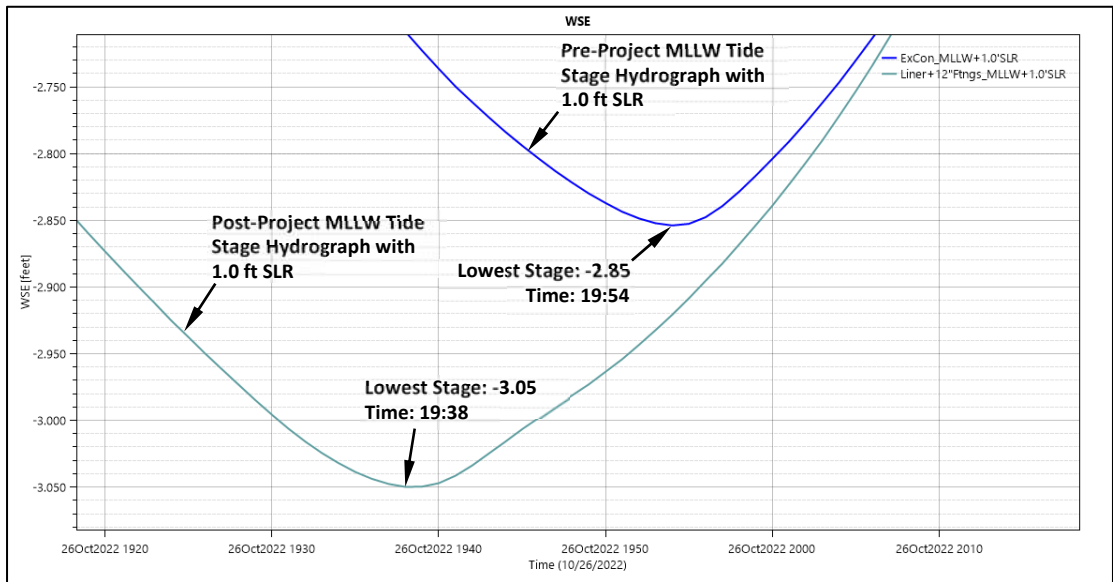

Figure 35 – Troughs of the pre- and post-project MLLW tide stage hydrographs with 1.0 ft SLR calculated in the portion of North Mill Pond south of Maplewood Avenue

The lower MLLW stage and reduced time to reach that stage are due to the proposed waterway opening modifications which would increase the rate that the portion of the pond south of the bridge drains during the ebb tide, allowing the water level south of the road to reach a lower stage before the flow reverses.

Figures 36 and 37 show the MLLW stage and flow hydrographs at the bridge calculated for pre- and post-project conditions with 1.0 ft SLR, respectively. The maximum flow through the bridge from south to north during the MLLW tide cycle with 1.0 ft SLR is 977 cfs for pre-project

conditions and 1,010 cfs for post-project conditions, an increase of 33 cfs, or approximately 3.4%. The maximum flow through the bridge from north to south during the MLLW tide cycle with 1.0 ft SLR is 1,216 cfs for pre-project conditions and 1,195 cfs for post-project conditions, a reduction of 21 cfs, or approximately 1.7%.

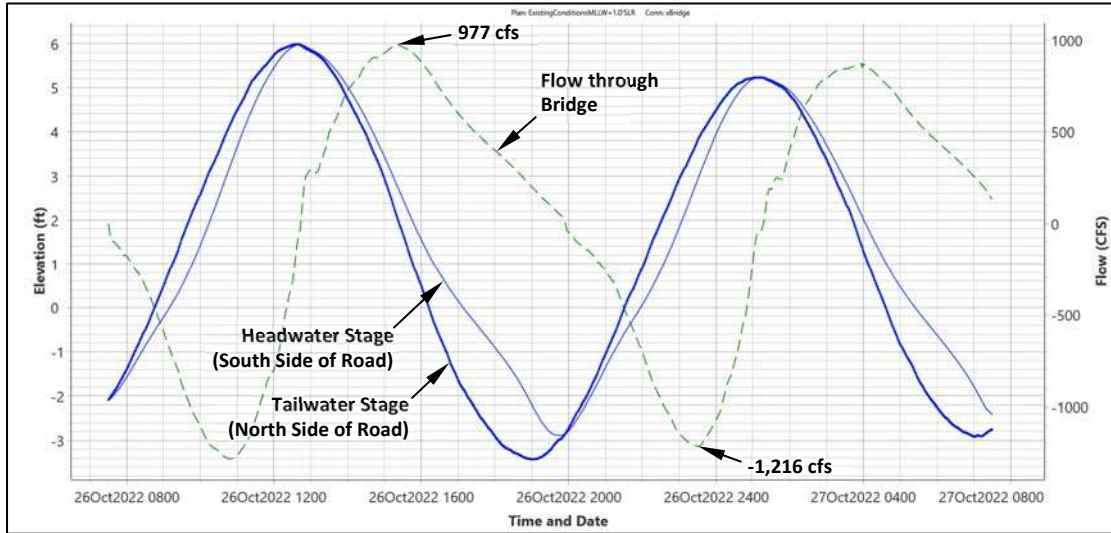

Figure 36 – Pre-project stage and flow hydrographs calculated at the bridge for MLLW with 1.0 ft SLR

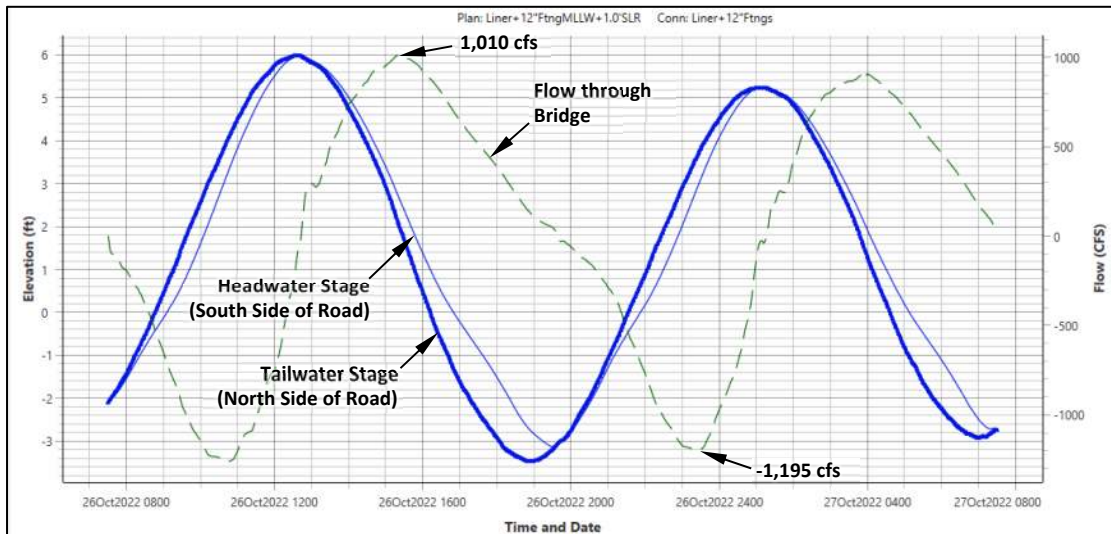

Figure 37 – Post-project stage and flow hydrographs calculated at the bridge for MLLW with 1.0 ft SLR

The models indicate that the proposed bridge rehabilitation would increase the peak flow rate through the bridge from south to north for the MLLW event with 1.0 ft SLR and therefore would not restrict tidal flows, but in fact would reduce the existing flow restriction during the ebb tide. The decreased peak flow rate from north to south during the flood tide also indicates that the project would reduce the existing flow restriction as this decrease is due to the faster rate that the pond south of Maplewood Avenue would fill (see Figure 34) which increases the tailwater elevation and reduces the maximum flow rate through the bridge.

C.5. Boundary Conditions for 50- and 100-year Storm Models

The 50- and 100-year rainfall runoff hydrographs from the Headwaters Consulting hydrology study were used as the upstream boundaries in the pre- and post-project 50- and 100-year storm models both with and without SLR. These are shown in Figures 38 and 39.

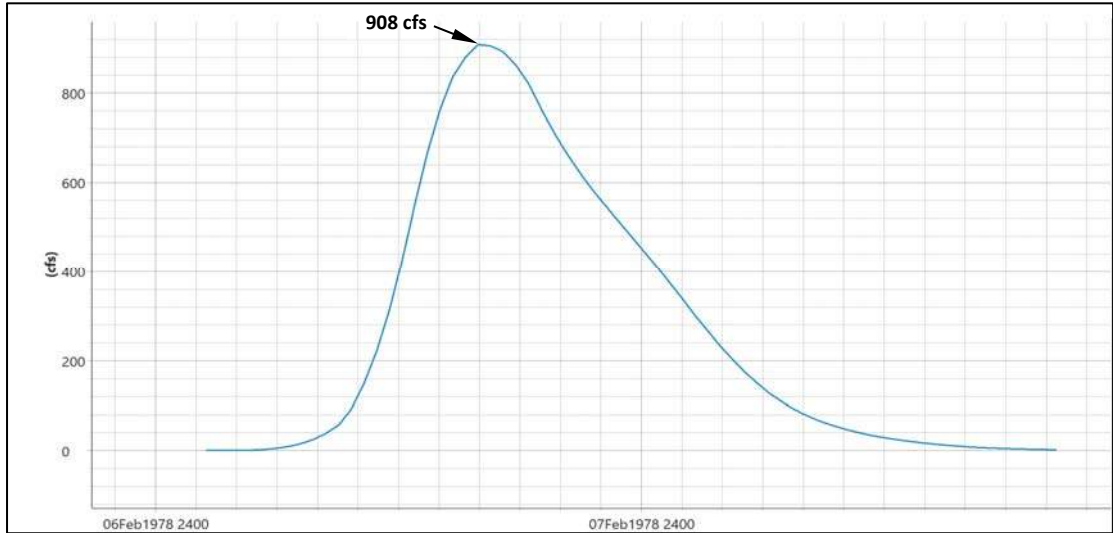

Figure 38 – 50-year rainfall runoff hydrograph used as the upstream boundary in the pre- and post-project 50-year storm models with and without SLR

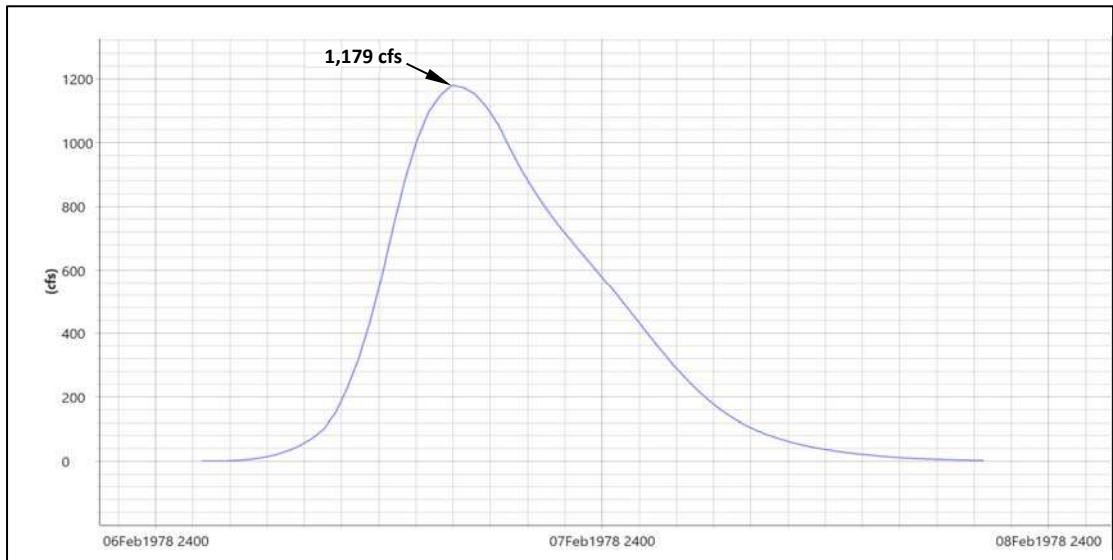

Figure 39 – 100-year rainfall runoff hydrograph used as the upstream boundary in the pre- and post-project 100-year storm models with and without SLR

Stage hydrographs representing the 50- and 100-year tidal storm surge events were used as the downstream boundaries in the storm models. These were developed from water levels measured at the NOAA Seavey Island tide station and the high water level exceedance probability curve published by NOAA for the tide gage (see Figure 40).

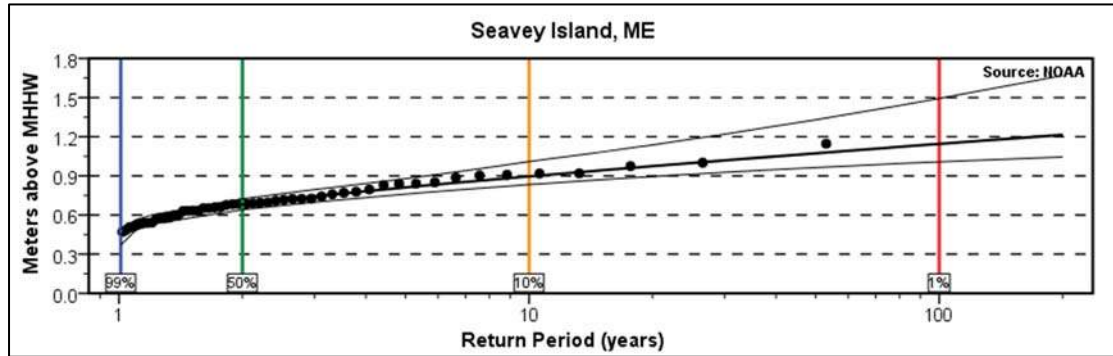

Figure 40 – High water annual exceedance probability curve for the Seavey Island tide station

The exceedance probability curve predicts the 100-year high water level is about 1.14 meters (3.74 ft) above mean higher high water (MHHW) and the 50-year high water level is approximately 1.07 meters (3.51 ft) above MHHW. Datum information for the tide station dated August 8, 2016 lists MHHW at the gage for the tidal epoch ending in 2001 as 4.22 ft above the North American Vertical Datum of 1988 (NAVD88). Adjusting the exceedance probability water level estimates to fixed elevations relative to NAVD88 results in the following peak tidal storm surge water levels.

Table 3 – Peak tidal storm surge water levels predicted at NOAA station 8419870 (Seavey Island, ME)

Recurrence Interval (years)	Peak Storm Surge Water Level (ft, NAVD88)
50	7.73
100	7.96

Section 3.2 of NHCRHC STAP (2014)⁴ suggests that present recurrence intervals of New Hampshire tidal storm surges be based upon the preliminary FEMA Flood Insurance Rate Maps (FIRMs) for coastal NH. The preliminary FIRM covering the project area (#33015C0259F), dated April 9, 2014, shows the Base Flood Elevation (BFE) at elevation 8 ft (NAVD88) (see Figure 41). The effective FIRM, dated January 29, 2021, also shows the BFE at elevation 8 ft. The BFE, which corresponds to the 1% annual chance, or 100-year, flood level, is only 0.04 ft higher than the 100-year peak tidal storm surge water level predicted from the exceedance probability curve for the Seavey Island tide gage.

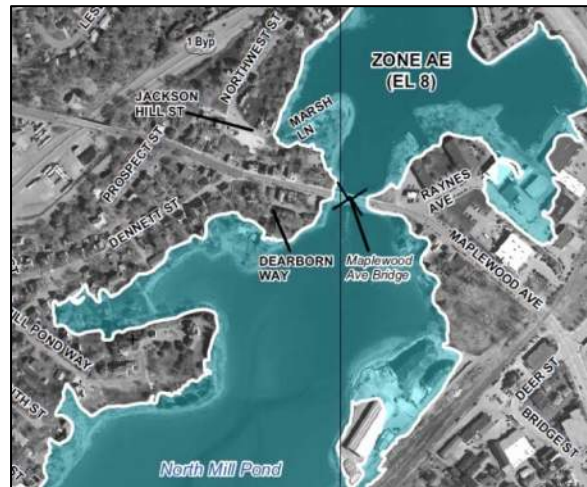

Figure 41 – Preliminary FIRM #33015C0259F

In keeping with the recommendations of NHCRHC STAP (2014), a 100-year peak tidal storm surge elevation of 8.00 ft was used in the pre- and post-project 100-year storm models without SLR. NHCRHC STAP (2014) does not provide guidance relative to 50-year tidal storm

⁴ Sea-level Rise, Storm Surges, and Extreme Precipitation in Coastal New Hampshire: Analysis of Past and Projected Future Trends. 2014. New Hampshire Coastal Risk and Hazards Commission Science and Technical Advisory Panel (NHCRHC STAP). <http://www.nhcrhc.org/wp-content/uploads/2014-STAP-final-report.pdf>.

surge water levels and none are published on the FEMA FIRM or in the FEMA Flood Insurance Study (FIS) for Rockingham County. Therefore, the 50-year peak tidal storm surge water level predicted by the exceedance probability curve for the Seavey Island tide gage (7.73 ft) was used in the pre- and post-project 50-year storm models without SLR.

The 50- and 100-year tidal storm surge stage hydrographs used for the downstream boundaries in the pre- and post-project storm models without SLR were estimated using water levels measured during the highest tidal storm surge cycle recorded at the Seavey Island gage. This occurred on February 7, 1978 with a peak elevation of 8.06 ft (NAVD88) (see Figure 42), which is 0.33 ft above the estimated 50-year peak tidal storm surge water level and 0.06 ft above the estimated 100-year peak water level.

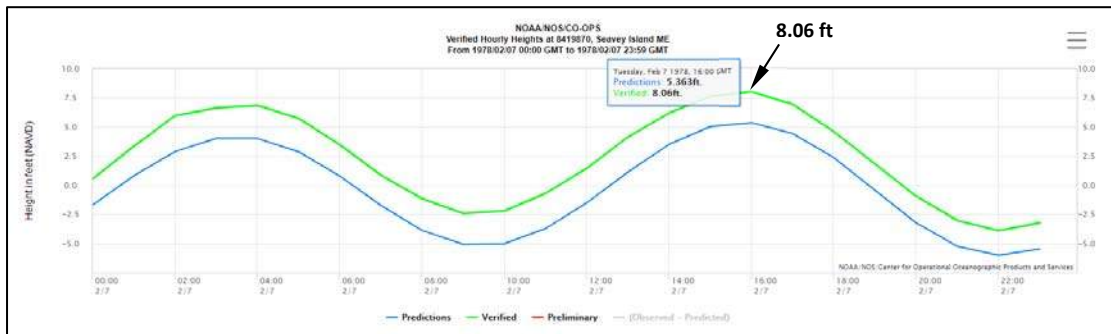

Figure 42 – Stage hydrograph showing water levels measured at the Seavey Island, ME tide gage on February 7, 1978. The green line represents measured water levels and the blue line represents predicted water levels.

Hourly water level data for February 6 through February 8, 1978 were downloaded from the NOAA website. The estimated 50- and 100-year peak tidal storm surge water levels are approximately 95.9% and 99.3% of the peak water level recorded at the gage on February 7, 1978, respectively. The measured water levels were multiplied by these percentages to generate the estimated 50- and 100-year tidal storm surge stage hydrographs used as the downstream boundaries in the storm models without SLR.

The 50- and 100-year freshwater inflow hydrographs have a duration of 42 hours with the peak flow occurring at hour 13.5 of the runoff events. The estimated storm surge stage hydrographs were generated so as to have the same 42-hour duration with peak water levels also occurring at hour 13.5. This results in the freshwater inflow hydrographs and the tidal storm surge stage hydrographs peaking concurrently so as to simulate near worst-case scenarios wherein the peak freshwater runoff enters North Mill Pond at the same time the storm tide reaches its maximum level. Figures 43 and 44 show the estimated 50- and 100-year tidal storm surge stage hydrographs used as the downstream boundaries in the storm models without SLR.



Figure 43 – Estimated 50-year tidal storm surge stage hydrograph used as the downstream boundary in the 50-year storm models without SLR

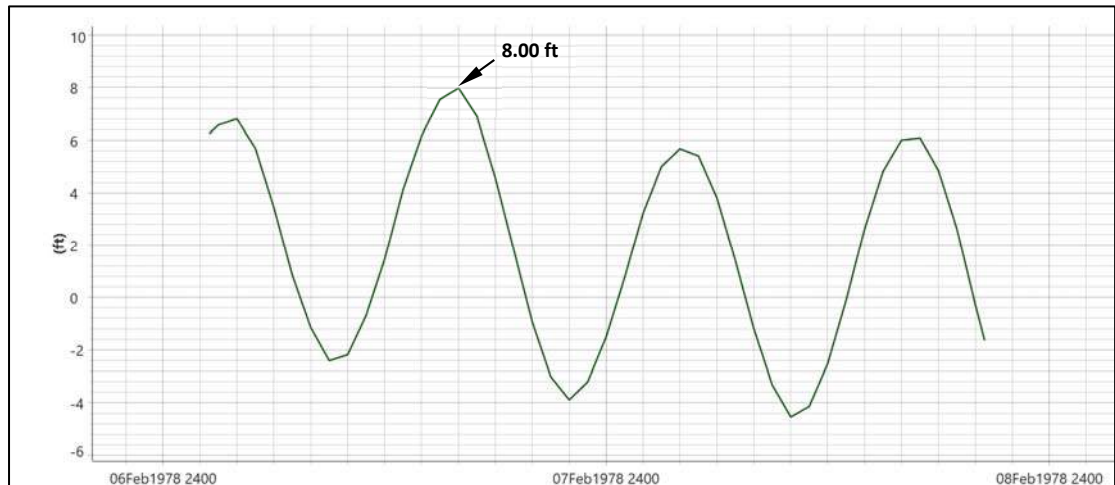

Figure 44 – Estimated 100-year tidal storm surge stage hydrograph used as the downstream boundary in the 100-year storm models without SLR

The 50- and 100-year tidal storm surge stage hydrographs used in the storm models with SLR were developed by adding 1.0 ft to the water level at each time step of the storm surge stage hydrographs used in the storm models without SLR. This results in peak water levels of 8.73 ft for the 50-year storm surge event and 9.00 ft for the 100-year storm surge event. The tidal storm surge stage hydrographs used as the downstream boundaries in the 50- and 100-year storm models with SLR are shown in Figures 45 and 46.

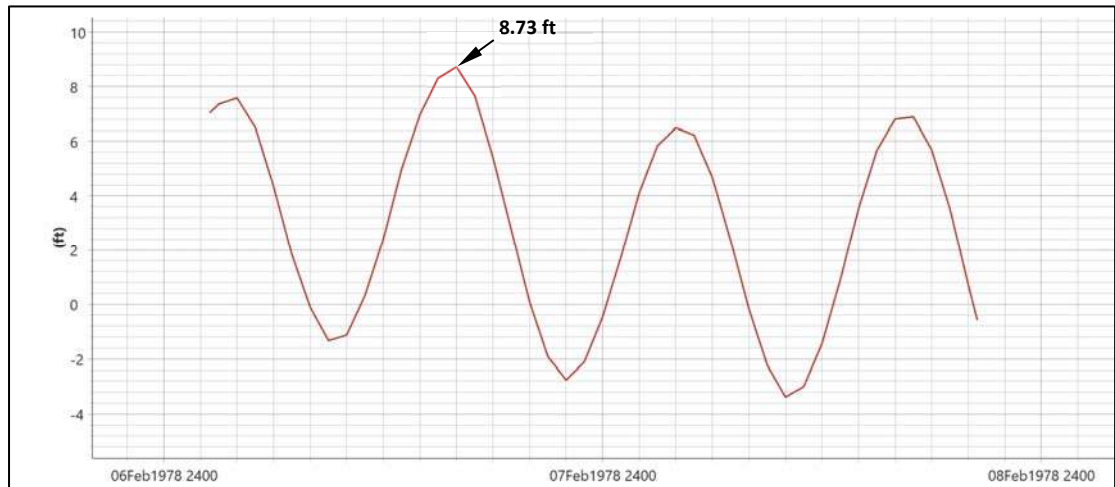

Figure 45 – Estimated 50-year tidal storm surge stage hydrograph used as the downstream boundary in the 50-year storm models with SLR

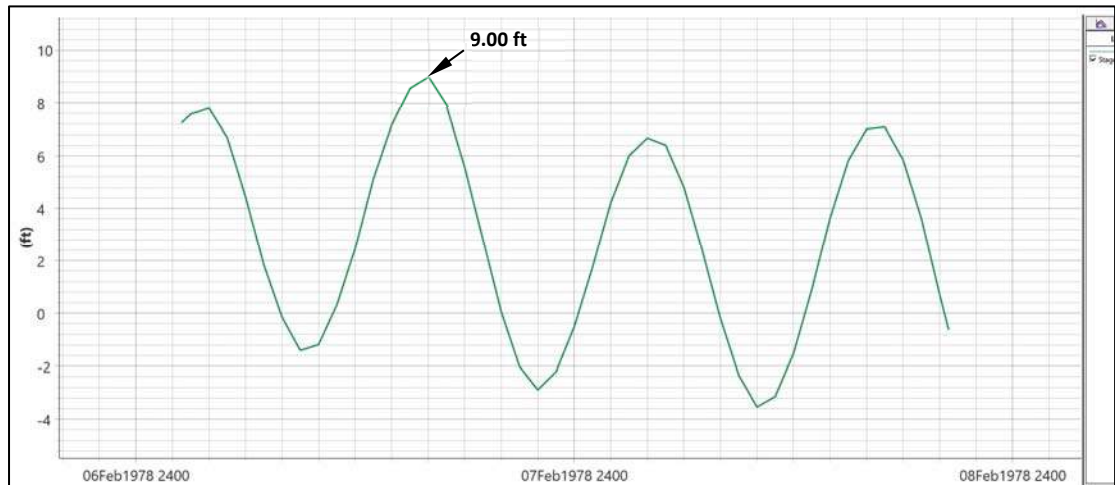

Figure 46 – Estimated 100-year tidal storm surge stage hydrograph used as the downstream boundary in the 100-year storm models with SLR

C.6. Pre- and Post-Project 50-year Storm Models without SLR

The pre-project 50-year storm model without SLR simulates the existing bridge geometry (see Section B.2.), runoff to North Mill Pond from the 50-year rainfall event (see Figure 38), and 50-year tidal storm surge unadjusted for SLR (see Figure 43).

The post-project 50-year storm model without SLR simulates the proposed bridge geometry after application of the geopolymer liner and removal of portions of the concrete footings (see Section B.3.), runoff to North Mill Pond from the 50-year rainfall event (see Figure 38), and 50-year tidal storm surge unadjusted for SLR (see Figure 43).

Table 4 summarizes the peak water levels in the portion of North Mill Pond south of Maplewood Avenue calculated with the pre- and post-project 50-year storm models without SLR. Note that maximum water levels at the south end of the pond below the outlet of the Bartlett Street culvert are slightly higher than in the majority of the pond. Similarly, maximum water levels at the bridge inlet are slightly lower than in the majority of the pond. The peak

water levels listed in Table 4, and in subsequent tables which report maximum water levels, have been calculated at the centroid of the portion of North Mill Pond on the south side of Maplewood Avenue and represent the peak water levels in the majority of the waterbody on the south side of the road.

Table 4 – Peak water levels in the portion of North Mill Pond on the south side of Maplewood Avenue calculated with the pre- and post-project 50-year storm models without SLR

Model	Peak Water Level in the portion of North Mill Pond on the South Side of Maplewood Avenue* (ft, NAVD88)
Pre-Project 50-year Storm Model without SLR	7.96
Post-Project 50-year Storm Model without SLR	7.95

**calculated at the centroid of the waterbody on the south side of Maplewood Ave. (N 211315, E 1224317)*

As shown in Table 4, the maximum water level at the centroid would decrease by 0.01 ft for a storm event which includes a 50-year tidal storm surge and a 50-year freshwater flood occurring simultaneously under present-day sea-level conditions.

Figure 47 shows the inundation area when the calculated water levels are at their maximum. The area shaded light blue represents the post-project inundation area. The pink area along the periphery of the light blue shading, which due to the small water level decrease is unnoticeable at the scale shown in Figure 47, represents the additional area inundated under pre-project conditions. Because the peak water level would decrease, the projects will not exacerbate flooding on properties along the shoreline of North Mill Pond under this storm scenario.

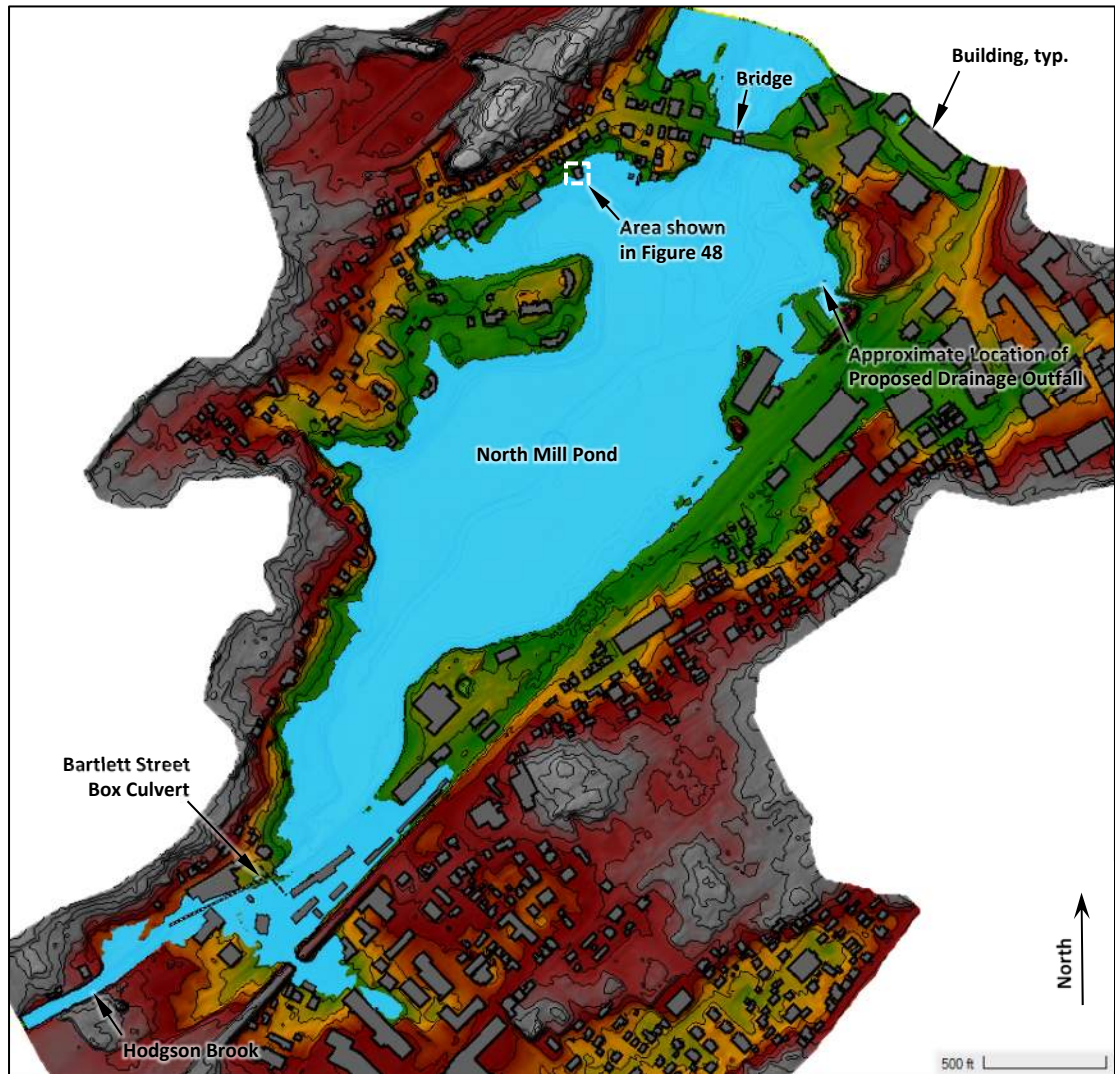

Figure 47 – Inundated areas calculated with the pre- and post-project 50-year storm models without SLR.

In order to visualize the magnitude of the reduced inundation in a typical area along the shoreline of North Mill Pond, Figure 48 shows a detailed view of an area southwest from the bridge.



Figure 48 – Detail view of a portion of the shoreline southwest from the bridge showing the inundated areas at the peak water levels calculated with the pre- and post-project 50-year storm models without SLR. The area shaded blue represents the post-project inundation area. The pink area along the periphery of the blue-shaded area represents the additional area flooded under pre-project conditions.

Figures 49 and 50 show the stage and flow hydrographs at the bridge calculated with the pre- and post-project 50-year storm models without SLR. Note that the maximum stage at the bridge inlet at the crest of each tide cycle is more or less equal to the water level at the bridge outlet except at the coincident peak of the freshwater inflow and tidal storm surge when the stage at the inlet is higher due to the freshwater inflow. Also note that due to the flow constriction created by the bridge and the grade control just south of the bridge inlet, low water levels in North Mill Pond south of the road at the trough of each tide cycle are higher than, and lag behind, low water levels at the bridge outlet with the greatest differences occurring at the tide cycle trough immediately after the coincident inflow and storm surge peaks. These same characteristics are also apparent on the stage hydrographs calculated with the other storm models.

The maximum flow through the bridge is 1,874 cfs for pre-project conditions and 1,907 cfs for post-project conditions. Both occur from south to north about two hours after the coincident inflow and storm surge peaks. Table 5 summarizes the peak flows through the bridge calculated with the pre- and post-project 50-year storm models without SLR.

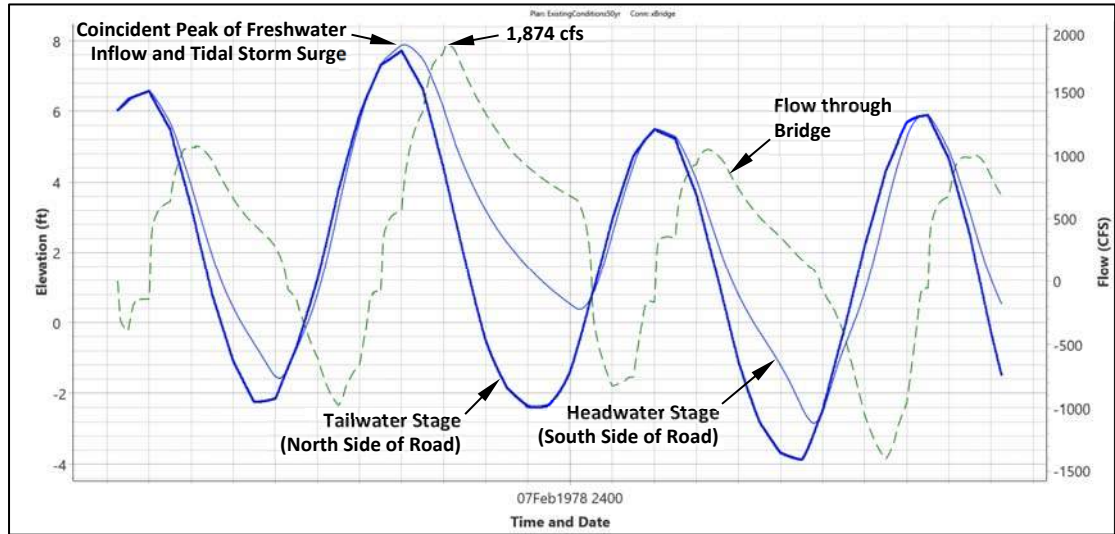

Figure 49 – Stage and flow hydrographs at the bridge calculated with the pre-project 50-year storm model without SLR

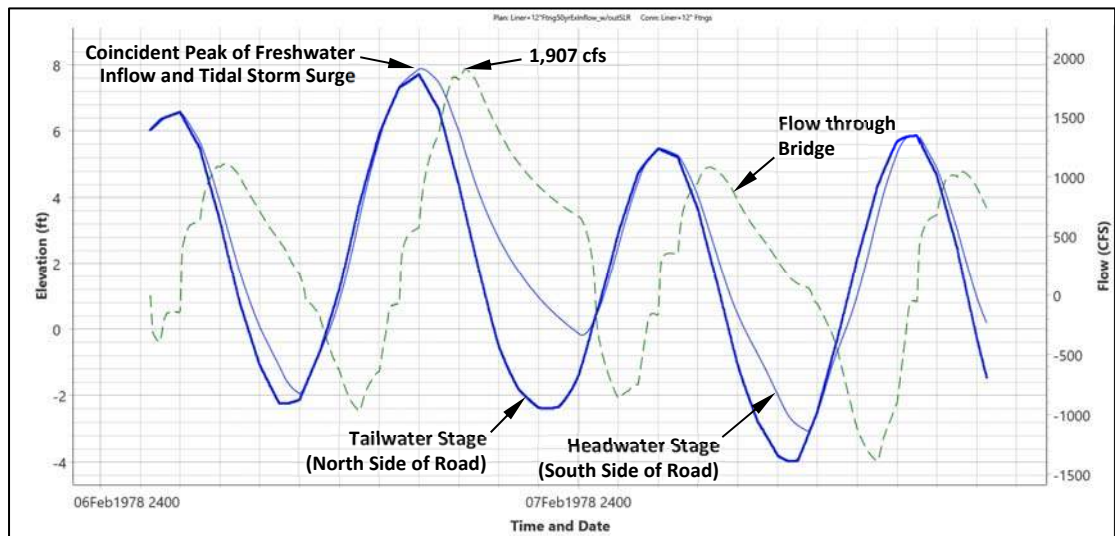

Figure 50 – Stage and flow hydrographs at the bridge calculated with the post-project 50-year storm model without SLR

Table 5 – Peak flows through the bridge calculated with the pre- and post-project 50-year storm models without SLR

Model	Peak Flow through Bridge (cfs)
Pre-Project 50-year Storm Model without SLR	1,874
Post-Project 50-year Storm Model without SLR	1,907

As shown in Table 5, due to the proposed waterway opening modifications, the maximum flow through the bridge would increase by 33 cfs for a storm event which includes a 50-year tidal storm surge and a 50-year freshwater flood occurring simultaneously under present-day sea-level conditions. This is an increase of approximately 1.8% and indicates that the bridge rehabilitation project will not restrict tidal flows as required by Env-Wt 904.07(d)(2).

C.7. Pre- and Post-Project 100-year Storm Models without SLR

The pre-project 100-year storm model without SLR includes the existing bridge geometry (see Section B.2.), runoff to North Mill Pond from the 100-year rainstorm (see Figure 39), and 100-year tidal storm surge unadjusted for SLR (see Figure 44).

The post-project 100-year storm model without SLR includes the proposed bridge geometry with the geopolymer liner applied and portions of the existing concrete footings removed (see Section B.3.), runoff to North Mill Pond from the 100-year rainstorm (see Figure 39), and 100-year tidal storm surge unadjusted for SLR (see Figure 44).

Table 6 lists the peak water levels calculated at the centroid of the portion of North Mill Pond south of Maplewood Avenue with the pre- and post-project 100-year storm models without SLR.

Table 6 – Peak water levels in the portion of North Mill Pond on the south side of Maplewood Avenue calculated with the pre- and post-project 100-year storm models without SLR

Model	Peak Water Level in the portion of North Mill Pond on the South Side of Maplewood Avenue* (ft, NAVD88)
Pre-Project 100-year Storm Model without SLR	8.41
Post-Project 100-year Storm Model without SLR	8.40

**calculated at the centroid of the waterbody on the south side of Maplewood Ave. (N 211315, E 1224317)*

The model results indicate that the maximum water level in the portion of North Mill Pond south of Maplewood Avenue would decrease by 0.01 ft for a storm which includes simultaneous 100-year tidal storm surge and 100-year freshwater flood events under current sea-level conditions.

Figures 51 and 52 show the pre- and post-project inundation areas associated with the calculated peak water levels listed in Table 6. Light blue shading indicates the post-project inundation area. Pink shading along the edge of the light blue-shaded area indicates the additional area flooded under pre-project conditions. Both the maximum water level and inundated area would decrease; therefore, the projects will not increase flooding on properties along the shoreline of North Mill Pond during the 100-year storm.

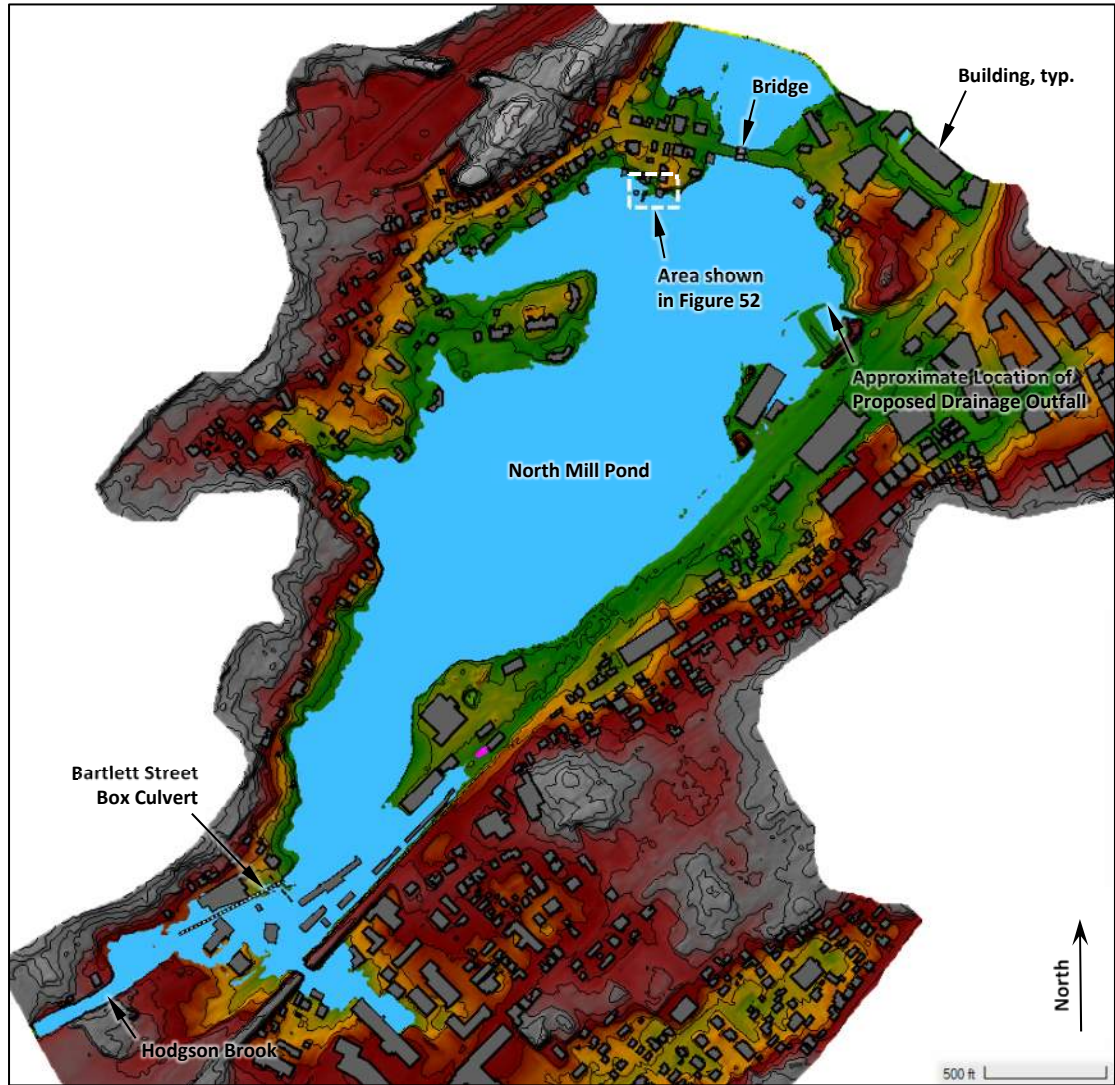

Figure 51 – Inundated areas calculated with the pre- and post-project 100-year storm models without SLR.

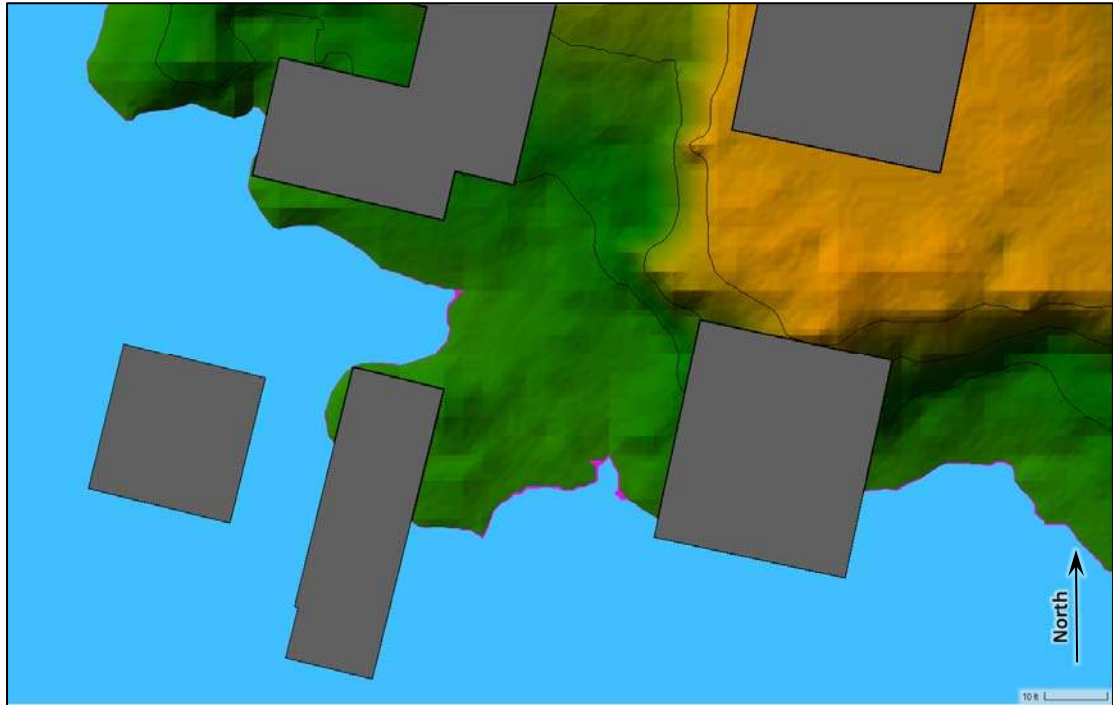

Figure 52 – Detail view of a portion of the North Mill Pond shoreline southwest from the bridge showing the inundated areas calculated with the pre- and post-project 100-year storm models without SLR. The area shaded blue represents the post-project inundation area. The pink area along the periphery of the blue-shaded area represents the additional area flooded under pre-project conditions.

Figures 53 and 54 show the stage and flow hydrographs at the bridge calculated with the pre- and post-project 100-year storm models without SLR and Table 7 summarizes the peak flows through the bridge, which are 2,129 cfs for pre-project conditions and 2,164 cfs for post-project conditions. Both occur from south to north about two hours after the coincident inflow and storm surge peaks.

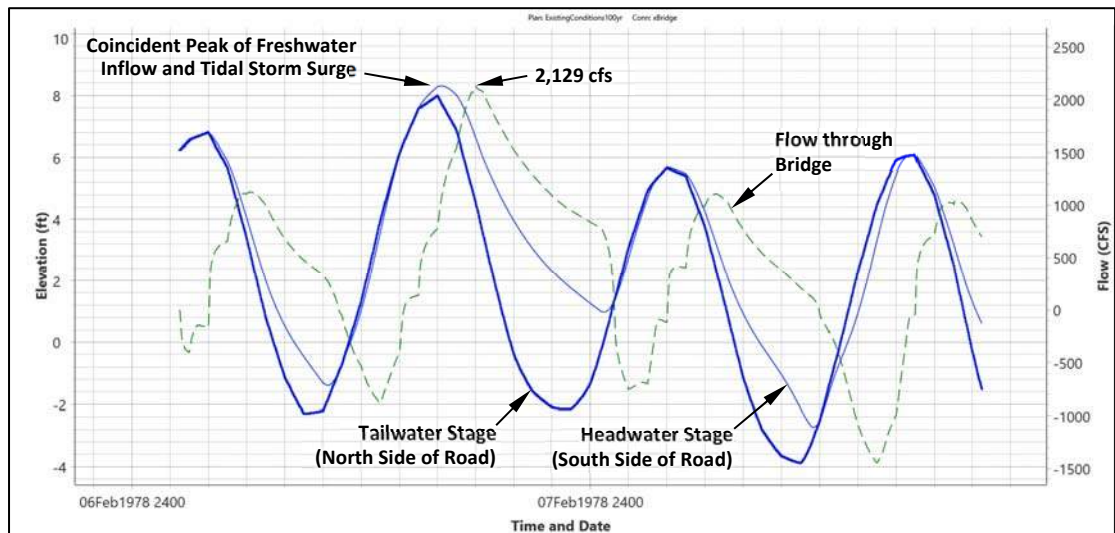

Figure 53 – Stage and flow hydrographs at the bridge calculated with the pre-project 100-year storm model without SLR

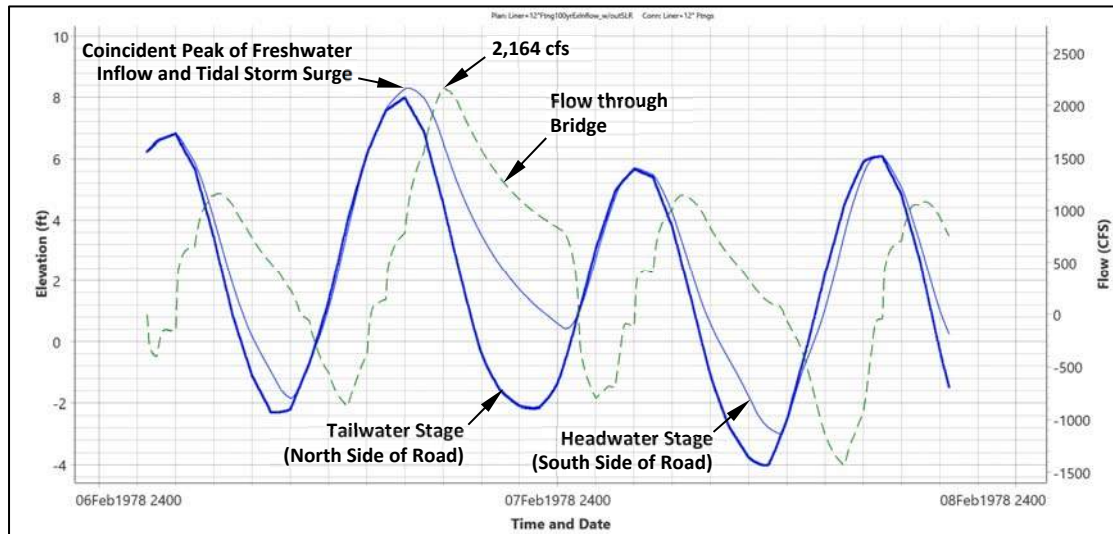

Figure 54 – Stage and flow hydrographs at the bridge calculated with the post-project 100-year storm model without SLR

Table 7 – Peak flows through the bridge calculated with the pre- and post-project 100-year storm models without SLR

Model	Peak Flow through Bridge (cfs)
Pre-Project 100-year Storm Model without SLR	2,129
Post-Project 100-year Storm Model without SLR	2,164

As shown in Table 7, for a storm event which includes a 100-year tidal storm surge and a 100-year freshwater flood occurring simultaneously under present-day sea-level conditions, the calculated peak flow through the bridge would increase by 35 cfs, or approximately 1.6%. The increased peak flow rate indicates that the proposed modifications to the bridge waterway opening will not restrict flows in accordance with Env-Wt 904.07(d)(2).

C.8. Pre- and Post-Project 50-year Storm Models with SLR

The pre-project 50-year storm model with SLR simulates the existing bridge geometry (see Section B.2.), runoff to North Mill Pond from the 50-year rainfall event (see Figure 38), and 50-year tidal storm surge adjusted for 1.0 ft SLR projected to occur during the bridge rehabilitation project design life (see Figure 45).

The post-project 50-year storm model with SLR simulates the proposed bridge geometry after the geopolymer liner has been applied (see Section B.3.), runoff to North Mill Pond from the 50-year rainfall event (see Figure 38), and 50-year tidal storm surge adjusted for 1.0 ft SLR (see Figure 45).

Table 8 summarizes the peak water levels in North Mill Pond south of Maplewood Avenue calculated with the pre- and post-project 50-year storm models with 1.0 ft SLR.

Table 8 – Peak water levels in the portion of North Mill Pond on the south side of Maplewood Avenue calculated with the pre- and post-project 50-year storm models with 1.0 ft SLR

Model	Peak Water Level in the portion of North Mill Pond on the South Side of Maplewood Avenue* (ft, NAVD88)
Pre-Project 50-year Storm Model with SLR	8.95
Post-Project 50-year Storm Model with SLR	8.94

**calculated at the centroid of the waterbody on the south side of Maplewood Ave. (N 211315, E 1224317)*

As shown in Table 8, with 1.0 ft of sea-level rise, the maximum water level in the portion of North Mill Pond south of Maplewood Avenue would decrease by 0.01 ft for a storm event which includes a 50-year tidal storm surge and a 50-year freshwater flood occurring simultaneously. This is the same decrease calculated for the 50-year storm event without SLR, which suggests that in regards to peak water levels, the projects would have more or less the same effect under both present-day sea-levels and those projected at the end of the bridge rehabilitation design life.

Figures 55 and 56 show the inundated areas at the peak water levels calculated with the pre- and post-project 50-year storm models with 1.0 ft SLR. Areas flooded under a scenario with the proposed bridge geometry and 1.0 ft SLR are shaded light blue. Pink shading along the limits of the light blue shading represents the additional areas which would be flooded with the existing bridge opening and 1.0 ft SLR. The models show that both the peak water level and inundation area would decrease; therefore, the projects will not increase flooding on properties along the shoreline of North Mill Pond under this scenario.

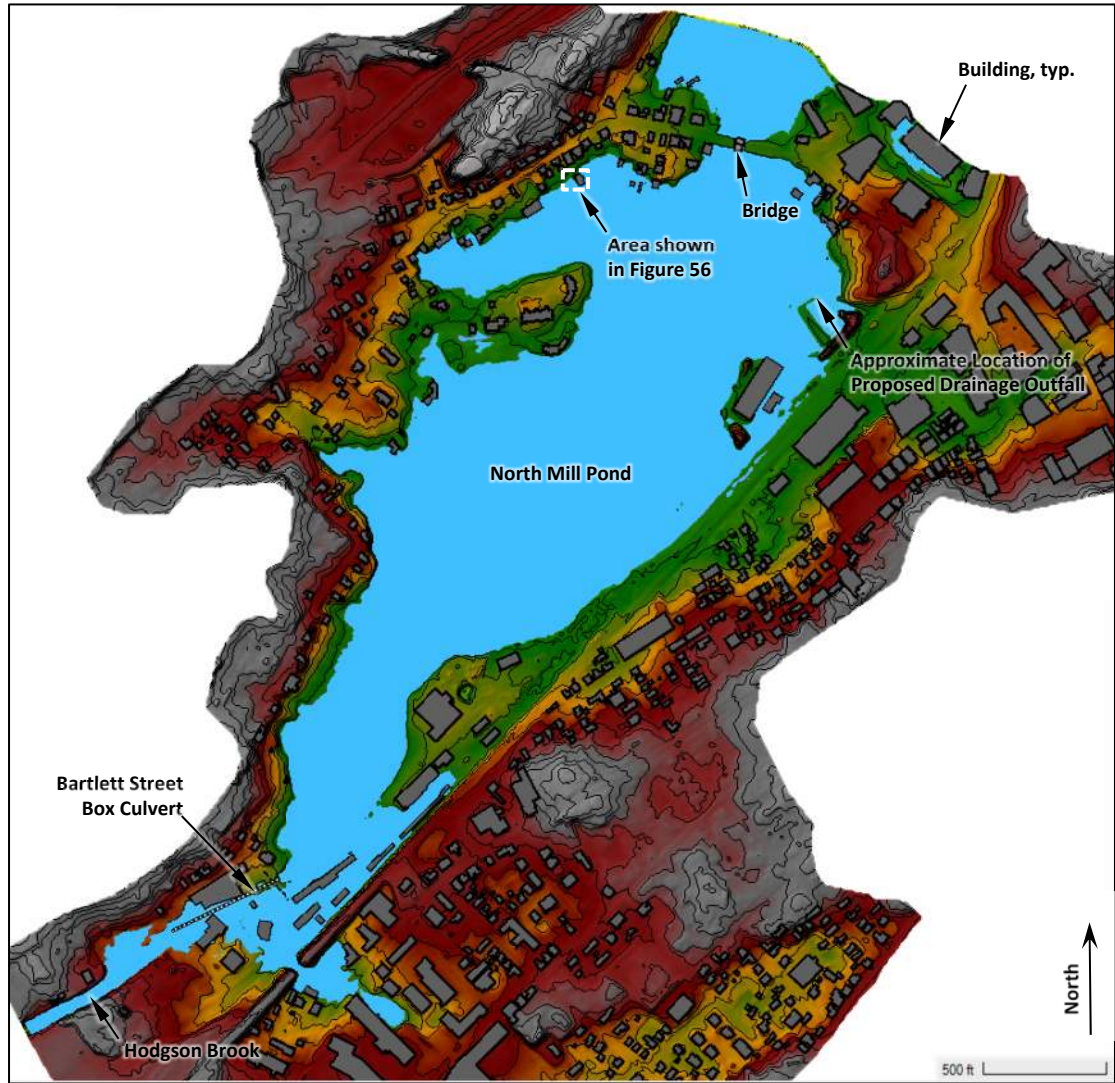

Figure 55 – Inundated areas calculated with the pre- and post-project 50-year storm models with 1.0 ft SLR



Figure 56 – Detail view of a portion of the shoreline southwest from the bridge showing the inundated areas at the peak water levels calculated with the pre- and post-project 50-year storm models with 1.0 ft SLR. The area shaded blue represents the post-project inundation area. The pink area along the periphery of the blue-shaded area represents the additional area flooded under pre-project conditions.

Figures 57 and 58 show the stage and flow hydrographs calculated at the bridge with the pre- and post-project 50-year storm models with 1.0 ft SLR. Maximum flows through the bridge are 2,016 cfs for pre-project conditions and 2,102 cfs for post-project conditions, both of which occur from south to north about two hours after the coincident freshwater inflow and tidal storm surge peaks. This is an increase of about 4.3% and indicates that the proposed waterway opening modifications would not restrict flows under a scenario which includes simultaneous 50-year tidal storm surge and 50-year freshwater flood events with 1.0 ft SLR.

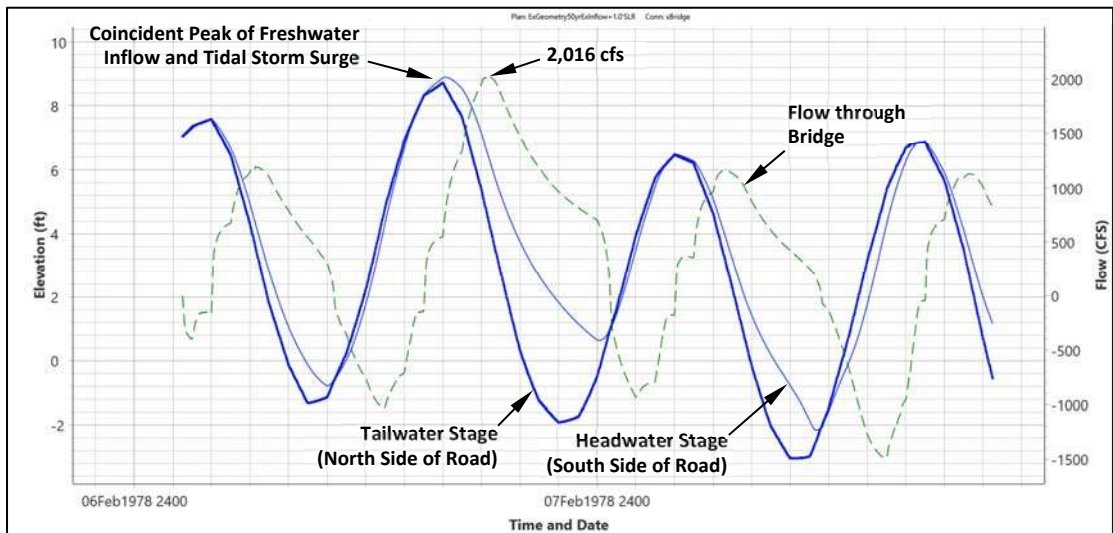

Figure 57 – Stage and flow hydrographs calculated at the bridge with the pre-project 50-year storm model with 1.0 ft SLR

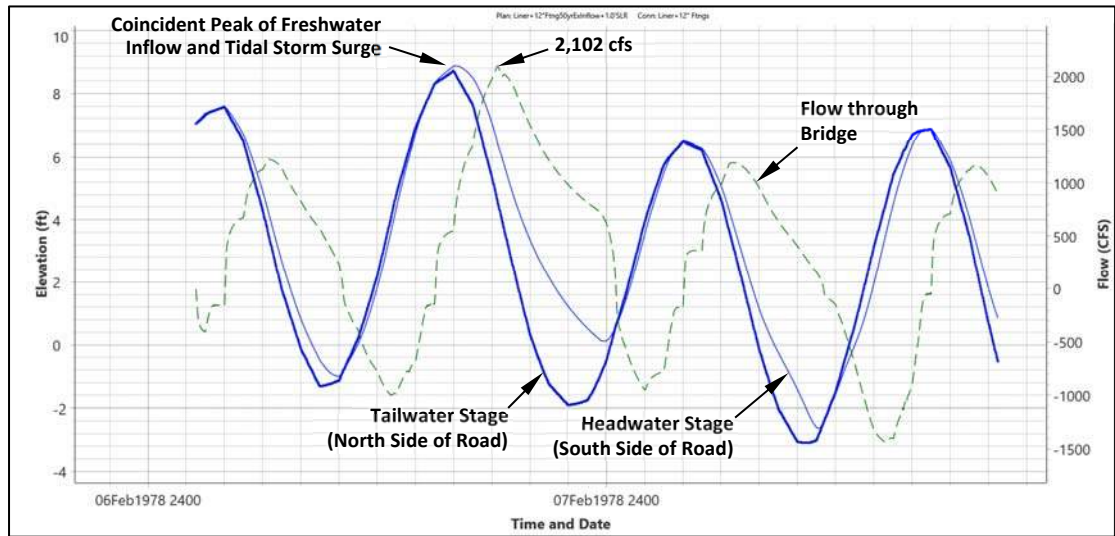

Figure 58 – Stage and flow hydrographs calculated at the bridge with the post-project 50-year storm model with 1.0 ft SLR

Table 9 – Peak flows through the bridge calculated with the pre- and post-project 50-year storm models with 1.0 ft SLR

Model	Peak Flow through Bridge (cfs)
Pre-Project 50-year Storm Model with SLR	2,016
Post-Project 50-year Storm Model with SLR	2,102

C.9. Pre- and Post-Project 100-year Storm Models with SLR

The pre-project 100-year storm model with SLR simulates a scenario which includes the existing bridge geometry (see Section B.2.), runoff to North Mill Pond from the 100-year rainfall event (see Figure 39), and 100-year tidal storm surge adjusted for 1.0 ft SLR projected to occur during the bridge rehabilitation project design life (see Figure 46).

The post-project 100-year storm model with SLR simulates a scenario which includes the proposed bridge geometry after the geopolymer liner has been applied and portions of the existing concrete footings have been removed (see Section B.3.), runoff to North Mill Pond from the 100-year rainfall event (see Figure 39), and 50-year tidal storm surge adjusted for 1.0 ft SLR (see Figure 46).

Table 10 lists the peak water levels calculated in the portion of North Mill Pond south of Maplewood Avenue with the pre- and post-project 100-year storm models with 1.0 ft SLR.

Table 10 – Peak water levels in the portion of North Mill Pond on the south side of Maplewood Avenue calculated with the pre- and post-project 100-year storm models with 1.0 ft SLR

Model	Peak Water Level in the portion of North Mill Pond on the South Side of Maplewood Avenue* (ft, NAVD88)
Pre-Project 100-year Storm Model with SLR	9.40
Post-Project 100-year Storm Model with SLR	9.39

*calculated at the centroid of the waterbody on the south side of Maplewood Ave. (N 211315, E 1224317)

As indicated in Table 10, the model results show that the maximum water level in the portion of North Mill Pond south of Maplewood Avenue would decrease by 0.01 ft for a storm which includes simultaneous 100-year tidal storm surge and 100-year freshwater flood events under conditions with 1.0 ft of sea-level rise. This is the same decrease calculated for the 100-year storm event without SLR, suggesting that with respect to maximum water levels, the proposed waterway opening modifications would have about the same effect under both present-day sea-levels and elevated sea-levels predicted during the bridge rehabilitation design life.

Figures 59 and 60 show the inundation areas when water levels calculated with the pre- and post-project 100-year storm models with 1.0 ft SLR are at their maximum elevation. Areas shaded light blue are inundated under post-project conditions with 1.0 ft SLR. Pink shading along the edge of the post-project inundation area (see Figure 60) represents the additional area which would be flooded under pre-project conditions with 1.0 ft SLR. The peak water level and inundation area would both decrease; therefore, the projects will not exacerbate flooding on properties along the shoreline of North Mill Pond under this storm and SLR scenario.

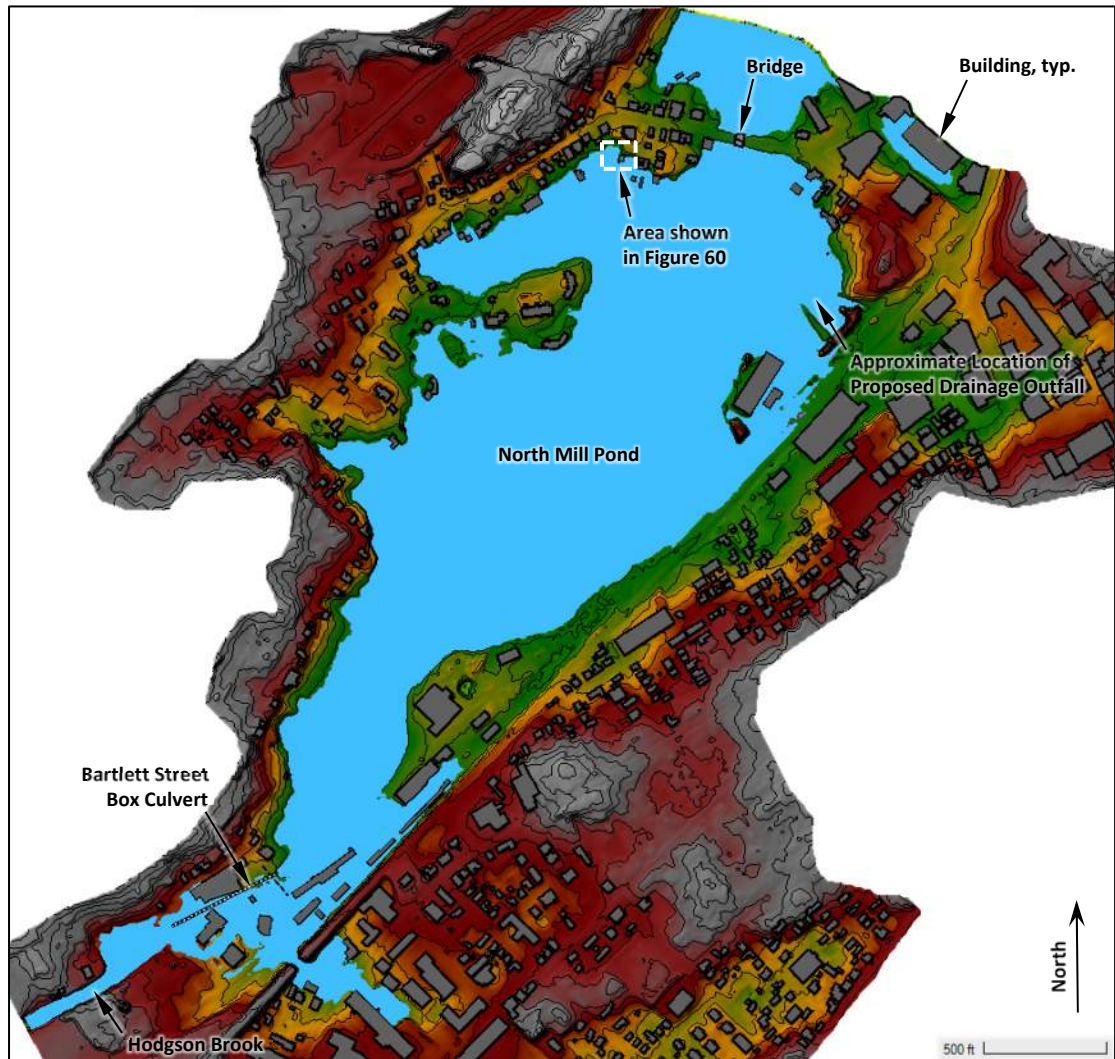

Figure 59 – Inundation areas calculated with the pre- and post-project 100-year storm models with 1.0 ft SLR

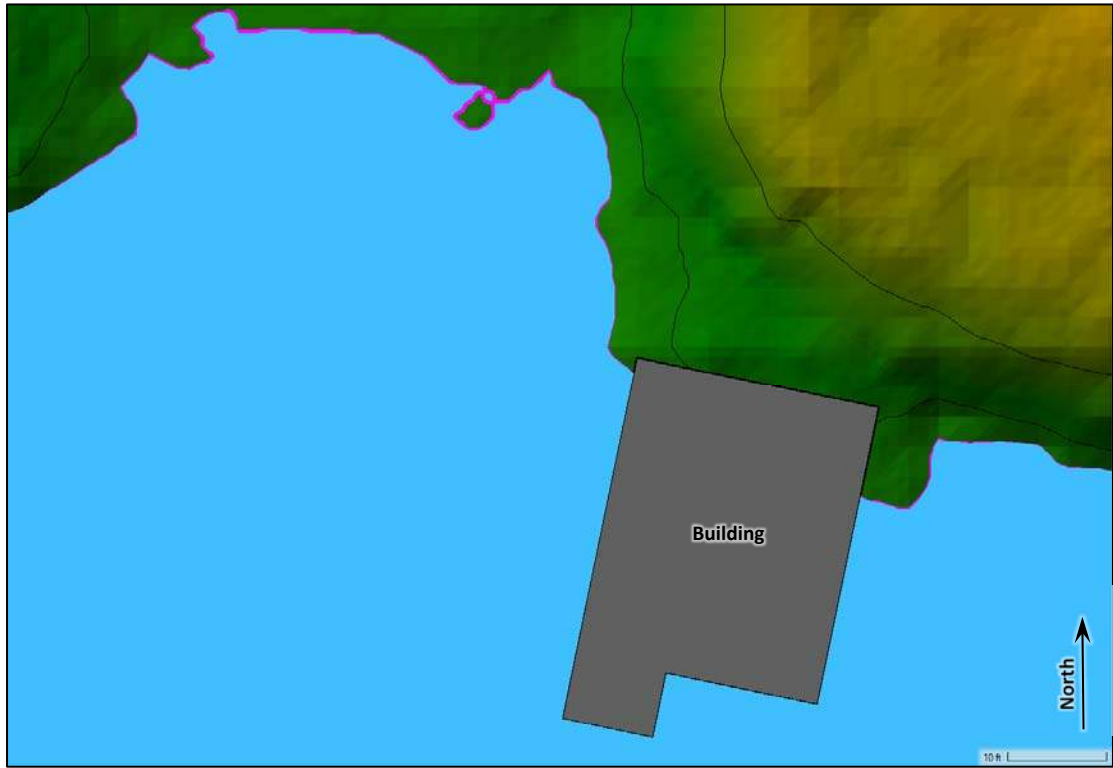

Figure 60 – Detail view of an area along the shore of North Mill Pond southwest from the bridge showing the inundated areas calculated with the pre- and post-project 100-year storm models with 1.0 ft SLR. The area shaded blue represents the post-project inundation area. The pink area along the periphery of the blue-shaded area represents the additional area flooded under pre-project conditions.

Figures 61 and 62 show the stage and flow hydrographs at the bridge calculated with the pre- and post-project 100-year storm models with 1.0 ft SLR. Maximum flows through the bridge are 2,209 cfs for pre-project conditions with 1.0 ft SLR and 2,250 cfs for post-project conditions with 1.0 ft SLR. Peak flows under both scenarios are from south to north and occur about two hours after the coincident freshwater inflow and tidal storm surge peaks.

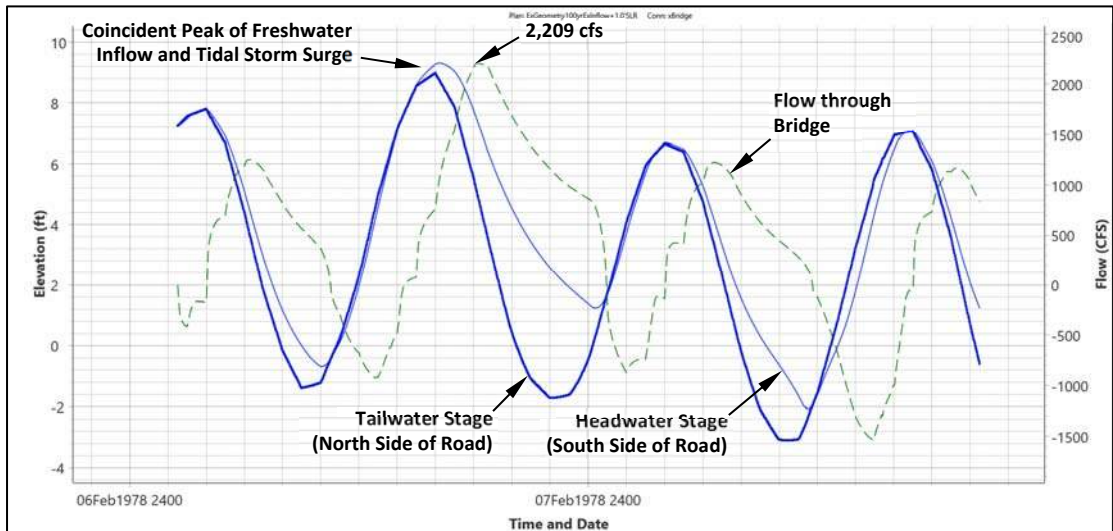

Figure 61 – Stage and flow hydrographs calculated at the bridge with the pre-project 100-year storm model with 1.0 ft SLR

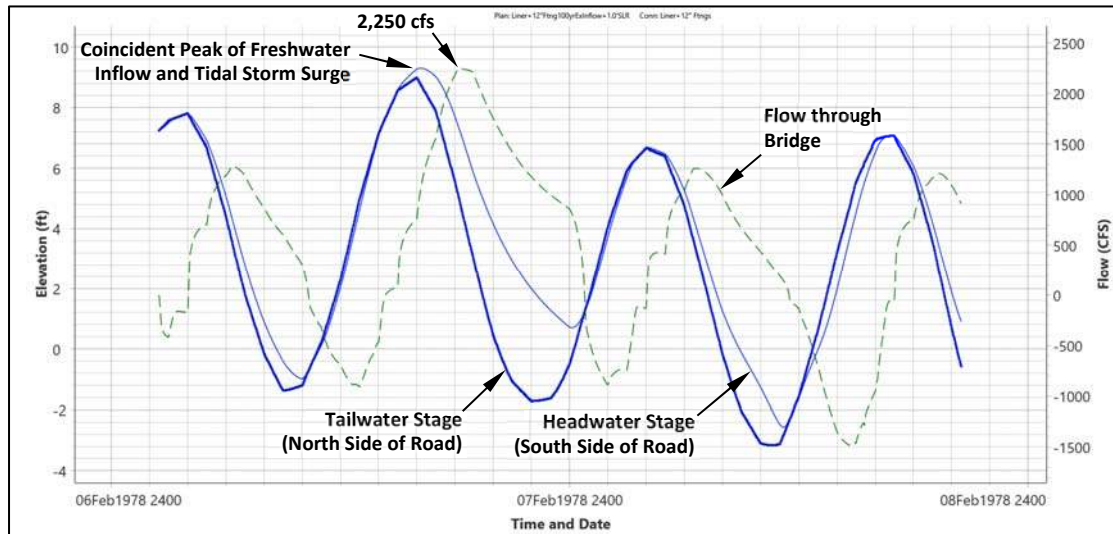

Figure 62 – Stage and flow hydrographs calculated at the bridge with the post-project 100-year storm model with 1.0 ft SLR

Table 11 – Peak flows through the bridge calculated with the pre- and post-project 100-year storm models with 1.0 ft SLR

Model	Peak Flow through Bridge (cfs)
Pre-Project 100-year Storm Model with SLR	2,209
Post-Project 100-year Storm Model with SLR	2,250

The models indicate the maximum flow through the bridge would increase by 41 cfs for a storm event which includes a 100-year tidal storm surge and a 100-year freshwater flood occurring simultaneously under conditions with 1.0 ft SLR. This is an increase of approximately 1.9% and indicates that the proposed modifications to the bridge waterway opening will not restrict flows under this storm and SLR scenario.

D. Env-Wt 603.05 Vulnerability Assessment

Results of the hydraulic analyses completed under Sections B and C have been used to complete a vulnerability assessment per Env-Wt 603.05.

D.1. Env-Wt 603.05(a)

The bridge rehabilitation project is intended to be a temporary repair which will maintain the functionality of the crossing until the structure can be completely replaced. It is expected to be in service for 10 to 20 years. Construction is anticipated to occur in the fall of 2023; therefore, the rehabilitated bridge is projected to be in service from 2023 to sometime between 2033 and 2043.

D.2. Env-Wt 603.05(b)

The corrugated metal arch bridge is a hydraulic structure that has been, and continues to be, frequently submerged since its construction in 1976. Granite block headwalls surround the metal arch at both ends of the structure and bedrock, boulders, and cobble line the pond

bottom at the crossing (see Figures 3 and 18). Therefore, there is little risk for erosion of the roadway embankment or degradation of the pond bottom. Furthermore, because the surface of Maplewood Avenue is about 3 ft higher than the FEMA BFE, there is little risk of the roadway being overtopped during the project design life. The only damage potential is corrosion of the metal arch from regular saltwater exposure, which the geopolymer liner is intended to mitigate. Due to these characteristics, the rehabilitated bridge will have a low sensitivity to inundation and therefore a high tolerance for flood risk per the Step 2 Table (Framework for Determining Project Tolerance for Flood Risk) in NHCFR STAP (2020). Similarly, the drainage outfall is intended to be frequently submerged and will be constructed of erosion and corrosion resistant materials. Consequently, it too has a low sensitivity to inundation and a high tolerance for flood risks.

Although the bridge rehabilitation and drainage outfall projects themselves have a low sensitivity to inundation and a high tolerance for flood risks, the existing residential and commercial properties near the pond have a high sensitivity to inundation and low tolerance for flood risks. As described in Section C, detailed hydraulic analyses have been performed to assess the impact on these properties. These analyses found that the projects will not increase flood levels or flood inundation under any of the modeled storm scenarios, either with or without SLR, and will therefore not increase the flood risks to these properties.

The “SLAMM 2022 – Initial Conditions” layer in the NH Coastal Viewer shows narrow bands of existing salt marsh along most of the west shoreline of North Mill Pond south of Maplewood Avenue and about half of the east shoreline (see Figure 63). These salt marshes were also observed in the field (see Figure 64). Salt marsh migration is driven primarily by changes to ordinary water levels rather than changes to infrequent, storm-induced water levels. Therefore, the results of the hydraulic models which simulate MHHW and MLLW under pre- and post-project conditions with and without SLR are useful for evaluating the likely effect of the projects on these salt marshes. As described in Sections B.7., B.8., C.3., and C.4., the proposed projects will not significantly alter water levels during typical astronomical tide cycles, either with or without SLR. Therefore, the projects are not expected to adversely impact the salt marshes in North Mill Pond. There are no sand dunes or other known valuable coastal resources in the area which could be affected by the projects.

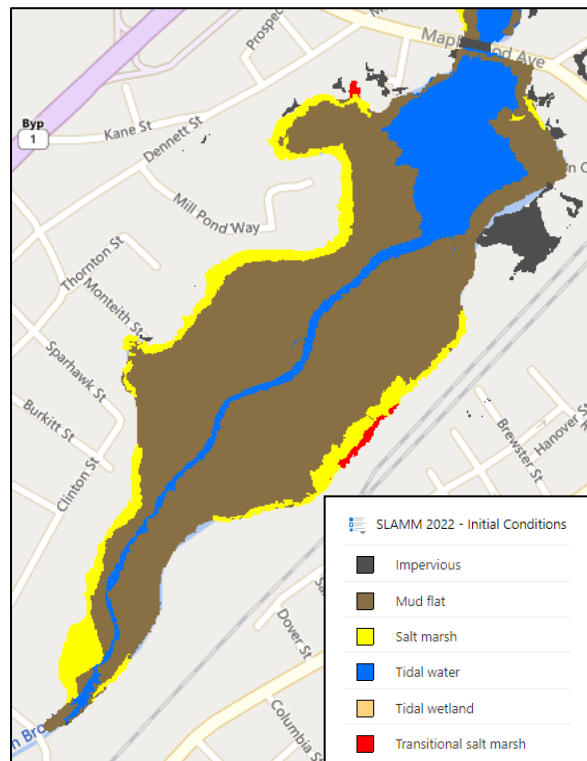

Figure 63 – SLAMM 2022 Initial Conditions layer showing existing salt marshes and other tidal resources in the portion of North Mill Pond south of Maplewood Avenue



Figure 64 – View north from the south end of North Mill Pond showing salt marshes along the shoreline (09-23-20)

D.3. Env-Wt 603.05(c)

NHCFR STAP (2019)⁵ states in Section 4.5 (Relative Sea-Level Rise Projections): “For the purposes of this summary report, the preferred RSLR projections for coastal New Hampshire from 2000 to 2050 are based on K14 for the RCP 4.5 scenario (Table 4.2; Figure 4.5).” A copy of Table 4.2 from NHCFR STAP (2019) is shown as Figure 65 below. Per this table, as compared to sea-levels in the year 2000, there is a 67% probability that sea-levels will be between 0.3 and 0.7 ft higher in the year 2030 and between 0.5 and 1.3 ft higher in 2050.

Table 4.2. Projected local sea-level rise (in feet) estimates above 2000 levels for NH based on K14 and the Seavey Island tide-gauge.

Year	RCP	Central Estimate	Likely Range	1-in-20 Chance	1-in-100 Chance	1-in-200 Chance	1-in-1000 Chance
		50% probability SLR meets or exceeds:	67% probability SLR is between:	5% probability SLR meets or exceeds:	1% probability SLR meets or exceeds:	0.5% probability SLR meets or exceeds:	0.1% probability SLR meets or exceeds:
2030	RCP 4.5*	0.5	0.3 - 0.7	0.9	1.0	1.1	1.3
2050	RCP 4.5*	0.9	0.5 - 1.3	1.6	2.0	2.3	2.9
2100	RCP 2.6	1.4	0.6 - 2.5	3.4	5.0	5.8	8.6
2100	RCP 4.5	1.9	1.0 - 2.9	3.8	5.3	6.2	8.7
2100	RCP 6.0	2.0	0.9 - 3.3	4.3	5.8	6.8	9.4
2100	RCP 8.5	2.6	1.5 - 3.8	4.9	6.5	7.5	10.0
2150	RCP 2.6	2.0	0.9 - 3.4	5.1	8.6	10.7	17.0
2150	RCP 4.5	2.7	1.2 - 4.6	6.4	9.9	11.7	18.1
2150	RCP 6.0**	N/A	N/A	N/A	N/A	N/A	N/A
2150	RCP 8.5	4.0	2.6 - 5.8	7.6	11.4	13.4	19.9

Figure 65 – Table 4.2 from NHCFR STAP (2019)

⁵ Wake, C., Knott, J., Lippmann, T., Stampono, M., Ballesterio, T., Bjerklie, D., Burakowski, E., Glidden, S., Hosseini-Shakib, I., Jacobs, J. (2019). *New Hampshire Coastal Flood Risk Summary – Part I: Science*. Prepared for the New Hampshire Coastal Flood Risk Science and Technical Advisory Panel. Report published by the University of New Hampshire, Durham, NH.

Step 3 Table A from NHCFR STAP (2020) lists recommended SLR estimates based on project design life and flood risk tolerance (see Figure 21). As described in Section D.1, the rehabilitated bridge is anticipated to be in service until sometime between 2033 and 2043. This most closely matches the year 2040 timeframe in Step 3 Table A. As described in Section D.2., the rehabilitated bridge will have a high tolerance for flood risk. Per Step 3 Table A, the recommended SLR estimate for a project with a 2040 timeframe and a high tolerance for flood risk is 1.0 ft relative to sea-levels in the year 2000. The hydraulic models described in Sections B and C which do not account for SLR use tide stage hydrographs simulating MHHW, MLLW, and tidal storm surge which are relative to the the tidal datum based on the 1983-2001 National Tidal Datum Epoch. Water levels at each time step of these stage hydrographs were raised by 1.0 ft to develop estimates of the MHHW, MLLW, and storm surge tide stage hydrographs which account for projected SLR during the bridge rehabilitation project design life. These SLR-adjusted tide stage hydrographs were used in the hydraulic models which account for SLR.

D.4. Env-Wt 603.05(d) and (e)

The area shaded light blue in Figure 66 represents the portion of the hydraulic study area which is currently within the 100-year floodplain. This is the area at and below the FEMA BFE, which is 8.0 ft (NAVD88). Pink shading indicates the additional areas which would be subject to flooding as a result of the projected SLR at the end of the project design life assuming the BFE is raised by 1.0 ft to elevation 9.0 ft.

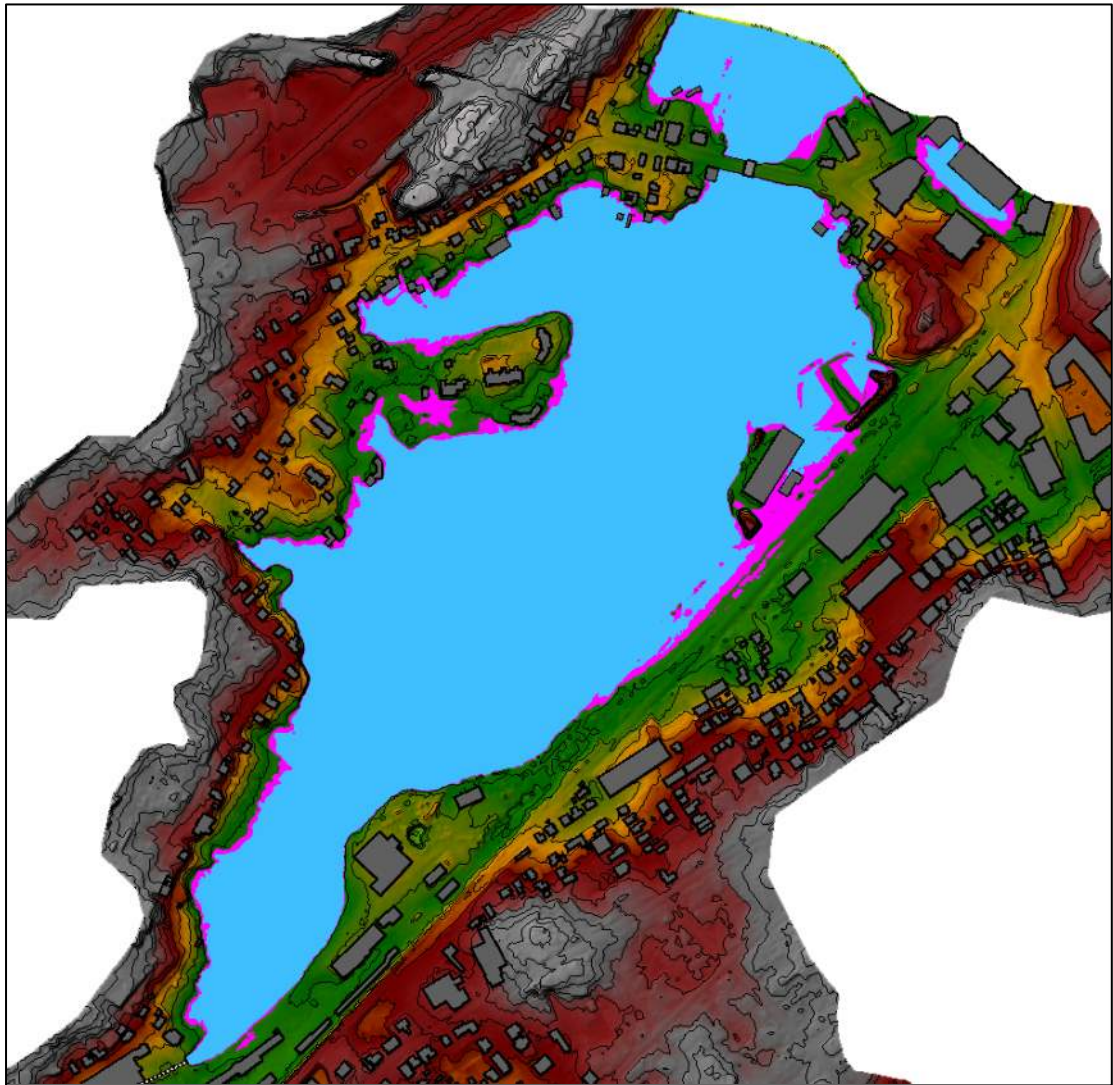

Figure 66 – Existing 100-year floodplain (blue shading, BFE 8.0 ft) and additional area subject to flooding with 1.0 ft SLR (pink shading, BFE 9.0 ft)

D.5. Env-Wt 603.05(f)

Since the bridge and outfall are intended to be submerged and Maplewood Avenue at the crossing would still be about 2 ft higher than the FEMA BFE increased by 1.0 ft to account for SLR (i.e., reasonably safe from flooding), no special design features are needed to accommodate SLR within the project design life. However, as described in Section C, SLR has been considered in the project design by evaluating the combined effects of the projects on flood levels, inundation extents, and bridge discharge capacities under scenarios where sea-levels have risen 1.0 ft.









D.6. Env-Wt 603.05(g)

There are no conflicts between the purpose of the projects and the vulnerability assessment results.

APPENDIX 1
SUPPORTING DOCUMENTATION FOR
HYDRAULIC MODELS

Maplewood Avenue Bridge Replacement Hydraulic Model Land Cover Mapping

Legend

-  2D Model Boundary
-  Open Water (n=0.040)
-  Impervious (n=0.025)
-  Railroad Tracks (n=0.035)
-  Grass with Scattered Trees (n=0.050)
-  Open Woods (n=0.080)
-  Thick Woods (n=0.120)
-  Brush (n=0.120)

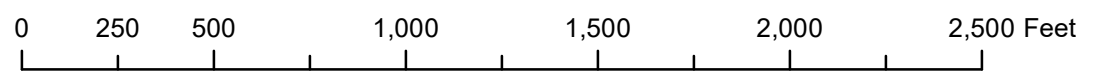
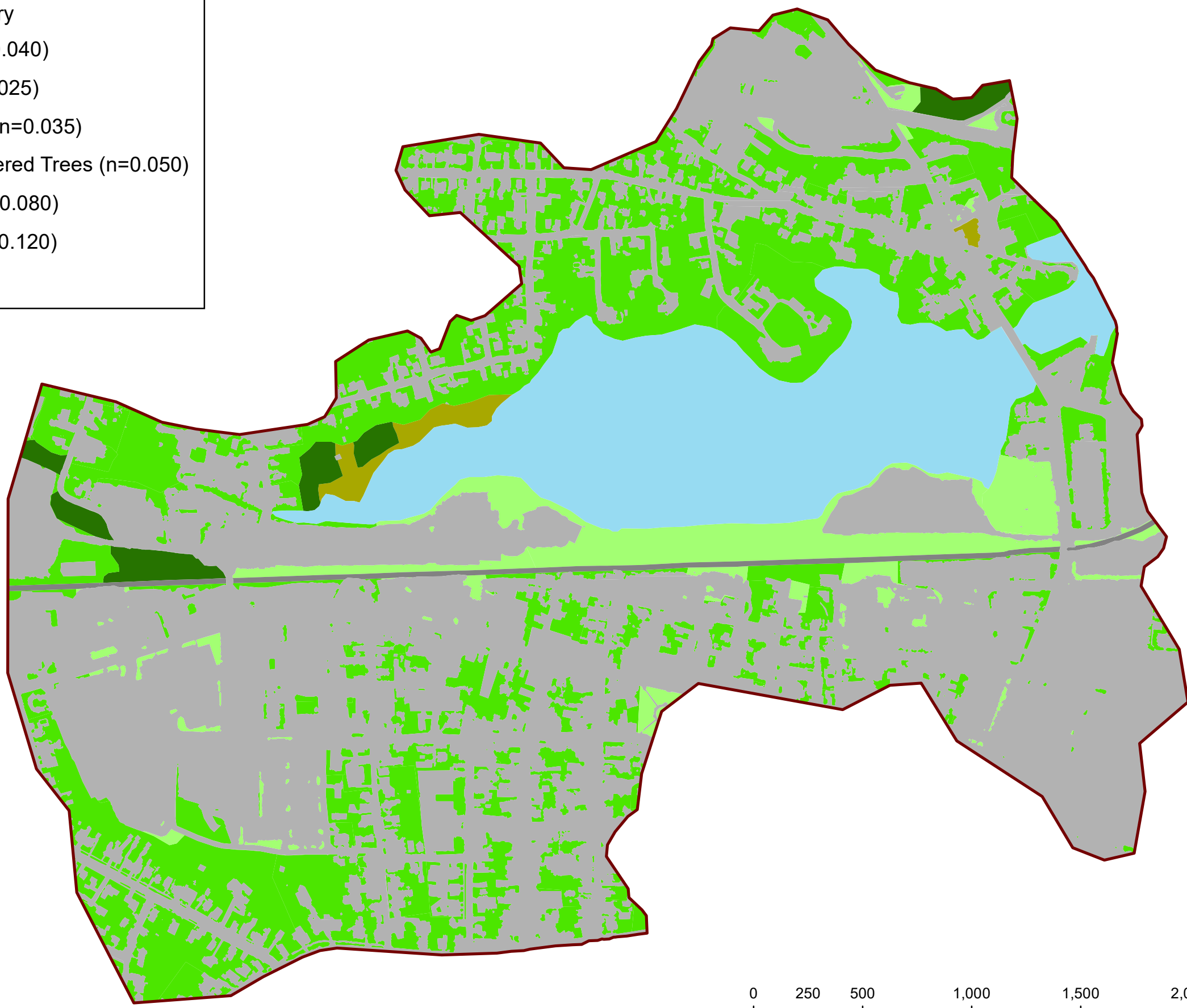

StreamStats Report - North Mill Pond at Maplewood Ave.

Region ID: NH
 Workspace ID: NH20221003123325873000
 Clicked Point (Latitude, Longitude): 43.07969, -70.76530
 Time: 2022-10-03 08:33:51 -0400

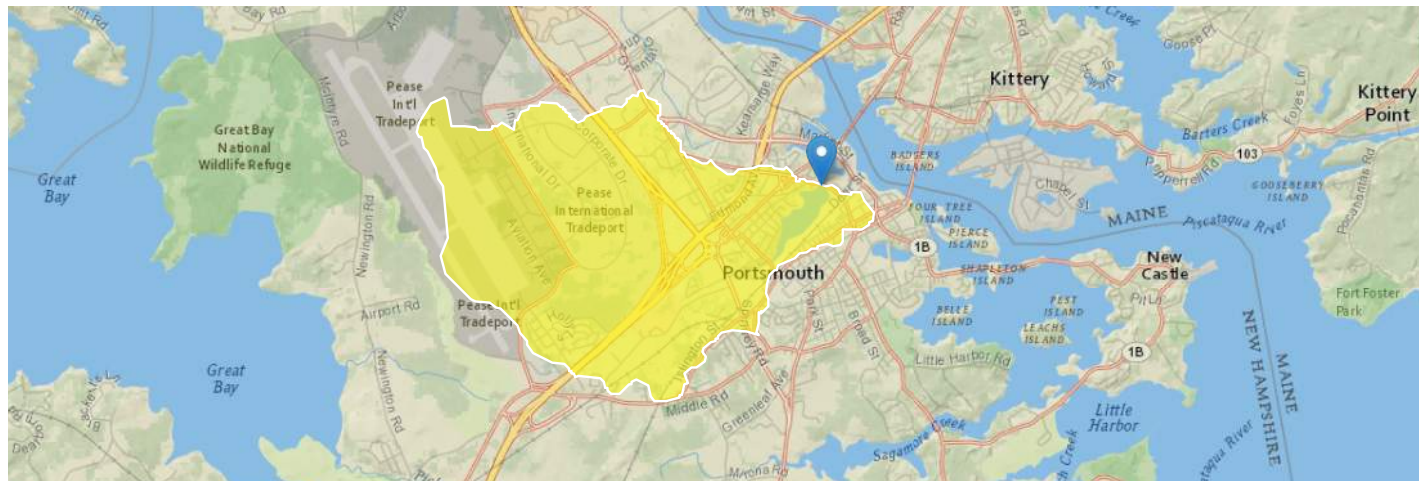

[-] Collapse All

Basin Characteristics

Parameter Code	Parameter Description	Value	Unit
APRAVPRE	Mean April Precipitation	4.429	inches
BSLDEM30M	Mean basin slope computed from 30 m DEM	1.47	percent
CONIF	Percentage of land surface covered by coniferous forest	6.3785	percent
CSL10_85	Change in elevation divided by length between points 10 and 85 percent of distance along main channel to basin divide - main channel method not known	19	feet per mi
DRNAREA	Area that drains to a point on a stream	4.16	square miles
ELEVMAX	Maximum basin elevation	101.072	feet
MIXFOR	Percentage of land area covered by mixed deciduous and coniferous forest	2.2681	percent
PREBC0103	Mean annual precipitation of basin centroid for January 1 to March 15 winter period	9.25	inches
PREG_03_05	Mean precipitation at gaging station location for March 16 to May 31 spring period	9.6	inches
PREG_06_10	Mean precipitation at gaging station location for June to October summer period	17.2	inches
TEMP	Mean Annual Temperature	46.223	degrees F
TEMP_06_10	Basinwide average temperature for June to October summer period	62.036	degrees F
WETLAND	Percentage of Wetlands	7.3067	percent

Peak-Flow Statistics

Peak-Flow Statistics Parameters [Peak Flow Statewide SIR2008 5206]

Parameter Code	Parameter Name	Value	Units	Min Limit	Max Limit
DRNAREA	Drainage Area	4.16	square miles	0.7	1290
APRAVPRE	Mean April Precipitation	4.429	inches	2.79	6.23
WETLAND	Percent Wetlands	7.3067	percent	0	21.8
CSL10_85	Stream Slope 10 and 85 Method	19	feet per mi	5.43	543

Peak-Flow Statistics Flow Report [Peak Flow Statewide SIR2008 5206]

PII: Prediction Interval-Lower, Plu: Prediction Interval-Upper, ASEp: Average Standard Error of Prediction, SE: Standard Error (other -- see report)

Statistic	Value	Unit	PII	Plu	ASEp	Equiv. Yrs.
50-percent AEP flood	115	ft ³ /s	69.6	190	30.1	3.2
20-percent AEP flood	196	ft ³ /s	117	329	31.1	4.7
10-percent AEP flood	266	ft ³ /s	155	455	32.3	6.2
4-percent AEP flood	363	ft ³ /s	204	644	34.3	8
2-percent AEP flood	445	ft ³ /s	243	815	36.4	9
1-percent AEP flood	546	ft ³ /s	287	1040	38.6	9.8
0.2-percent AEP flood	799	ft ³ /s	386	1650	44.1	11

Peak-Flow Statistics Citations

Olson, S.A., 2009, Estimation of flood discharges at selected recurrence intervals for streams in New Hampshire: U.S. Geological Survey Scientific Investigations Report 2008-5206, 57 p. (<http://pubs.usgs.gov/sir/2008/5206/>)

➤ Flow-Duration Statistics

Flow-Duration Statistics Parameters [Low Flow Statewide]

Parameter Code	Parameter Name	Value	Units	Min Limit	Max Limit
DRNAREA	Drainage Area	4.16	square miles	3.26	689
PREG_06_10	Jun to Oct Gage Precipitation	17.2	inches	16.5	23.1
TEMP	Mean Annual Temperature	46.223	degrees F	36	48.7

Flow-Duration Statistics Flow Report [Low Flow Statewide]

PII: Prediction Interval-Lower, Plu: Prediction Interval-Upper, ASEp: Average Standard Error of Prediction, SE: Standard Error (other -- see report)

Statistic	Value	Unit	PII	Plu	SE	ASEp
60 Percent Duration	1.94	ft ³ /s	1.41	2.6	18	18
70 Percent Duration	1.21	ft ³ /s	0.84	1.68	20.6	20.6
80 Percent Duration	0.64	ft ³ /s	0.388	0.991	28	28
90 Percent Duration	0.289	ft ³ /s	0.147	0.509	37.5	37.5
95 Percent Duration	0.164	ft ³ /s	0.0741	0.313	44.1	44.1
98 Percent Duration	0.0948	ft ³ /s	0.0356	0.203	54.3	54.3

Flow-Duration Statistics Citations

Flynn, R.H. and Tasker, G.D., 2002, Development of Regression Equations to Estimate Flow Durations and Low-Flow-Frequency Statistics in New Hampshire Streams: U.S. Geological Survey Scientific Investigations Report 02-4298, 66 p. (<http://pubs.water.usgs.gov/wrir02-4298>)

➤ Seasonal Flow Statistics

Seasonal Flow Statistics Parameters [Low Flow Statewide]

Parameter Code	Parameter Name	Value	Units	Min Limit	Max Limit
DRNAREA	Drainage Area	4.16	square miles	3.26	689
CONIF	Percent Coniferous Forest	6.3785	percent	3.07	56.2
PREBC0103	Jan to Mar Basin Centroid Precip	9.25	inches	5.79	15.1
BSLDEM30M	Mean Basin Slope from 30m DEM	1.47	percent	3.19	38.1
MIXFOR	Percent Mixed Forest	2.2681	percent	6.21	46.1
PREG_03_05	Mar to May Gage Precipitation	9.6	inches	6.83	11.5
TEMP	Mean Annual Temperature	46.223	degrees F	36	48.7
TEMP_06_10	Jun to Oct Mean Basinwide Temp	62.036	degrees F	52.9	64.4
PREG_06_10	Jun to Oct Gage Precipitation	17.2	inches	16.5	23.1
ELEVMAX	Maximum Basin Elevation	101.072	feet	260	6290

Seasonal Flow Statistics Disclaimers [Low Flow Statewide]

One or more of the parameters is outside the suggested range. Estimates were extrapolated with unknown errors.

Seasonal Flow Statistics Flow Report [Low Flow Statewide]

Statistic	Value	Unit
Jan to Mar15 60 Percent Flow	4.67	ft ³ /s
Jan to Mar15 70 Percent Flow	3.99	ft ³ /s
Jan to Mar15 80 Percent Flow	3.25	ft ³ /s
Jan to Mar15 90 Percent Flow	2.3	ft ³ /s
Jan to Mar15 95 Percent Flow	1.77	ft ³ /s
Jan to Mar15 98 Percent Flow	1.32	ft ³ /s
Jan to Mar15 7 Day 2 Year Low Flow	2.95	ft ³ /s
Jan to Mar15 7 Day 10 Year Low Flow	1.63	ft ³ /s
Mar16 to May 60 Percent Flow	4.82	ft ³ /s
Mar16 to May 70 Percent Flow	4.02	ft ³ /s
Mar16 to May 80 Percent Flow	4.18	ft ³ /s
Mar16 to May 90 Percent Flow	3.76	ft ³ /s
Mar16 to May 95 Percent Flow	3.4	ft ³ /s
Mar16 to May 98 Percent Flow	2.92	ft ³ /s
Mar16 to May 7 Day 2 Year Low Flow	3.39	ft ³ /s
Mar16 to May 7 Day 10 Year Low Flow	1.87	ft ³ /s
Jun to Oct 60 Percent Flow	0.536	ft ³ /s
Jun to Oct 70 Percent Flow	0.381	ft ³ /s
Jun to Oct 80 Percent Flow	0.225	ft ³ /s
Jun to Oct 90 Percent Flow	0.134	ft ³ /s
Jun to Oct 95 Percent Flow	0.0875	ft ³ /s
Jun to Oct 98 Percent Flow	0.0703	ft ³ /s
Jun to Oct 7 Day 2 Year Low Flow	0.157	ft ³ /s
Jun to Oct 7 Day 10 Year Low Flow	0.0492	ft ³ /s
Nov to Dec 60 Percent Flow	2.14	ft ³ /s
Nov to Dec 70 Percent Flow	1.37	ft ³ /s
Nov to Dec 80 Percent Flow	0.814	ft ³ /s
Nov to Dec 90 Percent Flow	0.42	ft ³ /s
Nov to Dec 95 Percent Flow	0.227	ft ³ /s
Nov to Dec 98 Percent Flow	0.107	ft ³ /s
Oct to Nov 7 Day 2 Year Low Flow	0.848	ft ³ /s
Oct to Nov 7 Day 10 Year Low Flow	0.182	ft ³ /s

Seasonal Flow Statistics Citations

Flynn, R.H. and Tasker, G.D.,2002, Development of Regression Equations to Estimate Flow Durations and Low-Flow-Frequency Statistics in New Hampshire Streams: U.S.Geological Survey Scientific Investigations Report 02-4298, 66 p. (<http://pubs.water.usgs.gov/wrir02-4298>)

➤ Low-Flow Statistics

Low-Flow Statistics Parameters [Low Flow Statewide]

Parameter Code	Parameter Name	Value	Units	Min Limit	Max Limit
DRNAREA	Drainage Area	4.16	square miles	3.26	689
TEMP	Mean Annual Temperature	46.223	degrees F	36	48.7
PREG_06_10	Jun to Oct Gage Precipitation	17.2	inches	16.5	23.1

Low-Flow Statistics Flow Report [Low Flow Statewide]

PII: Prediction Interval-Lower, Plu: Prediction Interval-Upper, ASEp: Average Standard Error of Prediction, SE: Standard Error (other -- see report)

Statistic	Value	Unit	PII	Plu	SE	ASEp
7 Day 2 Year Low Flow	0.154	ft ³ /s	0.0553	0.327	55.7	55.7
7 Day 10 Year Low Flow	0.0477	ft ³ /s	0.0111	0.125	79.4	79.4

Low-Flow Statistics Citations

Flynn, R.H. and Tasker, G.D., 2002, Development of Regression Equations to Estimate Flow Durations and Low-Flow-Frequency Statistics in New Hampshire Streams: U.S. Geological Survey Scientific Investigations Report 02-4298, 66 p. (<http://pubs.water.usgs.gov/wrir02-4298>)

USGS Data Disclaimer: Unless otherwise stated, all data, metadata and related materials are considered to satisfy the quality standards relative to the purpose for which the data were collected. Although these data and associated metadata have been reviewed for accuracy and completeness and approved for release by the U.S. Geological Survey (USGS), no warranty expressed or implied is made regarding the display or utility of the data for other purposes, nor on all computer systems, nor shall the act of distribution constitute any such warranty.

USGS Software Disclaimer: This software has been approved for release by the U.S. Geological Survey (USGS). Although the software has been subjected to rigorous review, the USGS reserves the right to update the software as needed pursuant to further analysis and review. No warranty, expressed or implied, is made by the USGS or the U.S. Government as to the functionality of the software and related material nor shall the fact of release constitute any such warranty. Furthermore, the software is released on condition that neither the USGS nor the U.S. Government shall be held liable for any damages resulting from its authorized or unauthorized use.

USGS Product Names Disclaimer: Any use of trade, firm, or product names is for descriptive purposes only and does not imply endorsement by the U.S. Government.

Application Version: 4.10.1

StreamStats Services Version: 1.2.22

NSS Services Version: 2.2.1

MAPLEWOOD AVE BRIDGE IN PORTSMOUTH, NH TIDAL STUDY (DOUCET SURVEY, LLC (DS~6032)) JUNE 16, 2022

KNOWN DATA AT SEAVEY ISLAND, ME STATION 8419870 (CONTROL STATION: 8418150 PORTLAND, ME) EPOCH 1983-2001 (STATUS ACCEPTED DEC. 6, 2021)		
5.87'	HAT	HIGHEST ASTRONOMICAL TIDE - REFERENCE LINE - HOTL
4.18'	MHHW	MEAN HIGHER-HIGH WATER
3.76'	MHW	MEAN HIGH WATER
-0.32'	MTL	MEAN TIDE LEVEL
-0.25'	MSL	MEAN SEA LEVEL
-0.26'	DTL	MEAN DIURNAL TIDE LEVEL
-4.39'	MLW	MEAN LOW WATER
-4.71'	MLLW	MEAN-LOWER-LOW WATER
0.00'	NAVD88	NORTH AMERICAN VERTICAL DATUM OF 1988
-6.98'	STND	STATION DATUM
8.89'	GT	GREAT DIURNAL RANGE
8.16'	MN	MEAN RANGE OF TIDE
0.42'	DHQ	MEAN DIURNAL HIGH WATER INEQUALITY
0.31'	DLQ	MEAN DIURNAL LOW WATER INEQUALITY

PRELIMINARY DATA AT CONTROL STATION, SEAVEY ISLAND, ME STATION 8419870 (DATUM NAVD88)	
DATE: 2022-05-27	
3.65'	HIGH WATER AT 10:12 (GMT TIMEZONE: 14:12)
DATE: 2022-06-02	
3.26'	HIGH WATER AT 14:18 (GMT TIMEZONE: 18:18)
DATE: 2022-06-07	
-3.56'	LOW WATER AT 11:48 (GMT TIMEZONE: 15:48)

SITE DATA AT SUBORDINATE STATION BY NORTHEASTERLY (OCEAN-SIDE) OF MAPLEWOOD BRIDGE, PORTSMOUTH, NH	
DATE: 2022-05-27	
3.51'	HIGH WATER AT 10:48 (GMT TIMEZONE: 14:48)
DATE: 2022-06-02	
3.14'	HIGH WATER AT 14:40 (GMT TIMEZONE: 18:40)
DATE: 2022-06-07	
-3.36'	LOW WATER AT 11:52 (GMT TIMEZONE: 15:52)

FINAL TIDAL STUDY INFORMATION		
	MAPLEWOOD AVE BRIDGE	SEAVEY ISLAND
	ELEV.	ELEV.
HAT	5.6'	5.87'
MHHW	4.0'	4.18'
MHW	3.6'	3.76'
MTL	-0.3'	-0.32'
MLW	-4.2'	-4.39'
MLLW	-4.5'	-4.71'
NAVD88	0.0'	0.00'

APPENDIX 2
BRIDGE REHABILITATION PROJECT
HYDROLOGY STUDY REPORT

February 1, 2021

Jillian A. Semprini, P.E.
Hoyle, Tanner & Associates, Inc.
Pease International Tradeport
100 International Drive, Suite 360
Portsmouth, NH 03801
(603) 431-2520, ext 28
jsemprini@hoyletanner.com

Subject: **Maplewood Avenue over North Mill Pond Hydrologic Analysis
Portsmouth, NH**

Jillian:

This letter describes the hydrologic analysis we have completed for the Maplewood Avenue over North Mill Pond bridge replacement project in Portsmouth. Methods and results of the hydrology study are described below and supporting plans and calculations are attached.

A. Overview

Our approach to the hydrologic analysis was based on the requirements and recommendations included in the following documents:

- *Bridge Design Manual, Chapter 2, Bridge Selection*. January 2015 – v 2.0 (Revised August 2018). NH Department of Transportation (NHDOT); and
- *Sea-level Rise, Storm Surges, and Extreme Precipitation in Coastal New Hampshire: Analysis of Past and Projected Future Trends*. 2014. New Hampshire Coastal Risk and Hazards Commission Science and Technical Advisory Panel (NHCRHC STAP). <http://www.nhcrhc.org/wp-content/uploads/2014-STAP-final-report.pdf>.

Maplewood Avenue is classified as a Tier 5 highway (i.e. local road). Per the NHDOT Bridge Design Manual, the design flood for calculating freeboard to the superstructure of bridges on local roads is the 50-year event and the design flood for substructure scour analysis is the 100-year event.

The SCS unit hydrograph method was used with the HydroCAD computer program to estimate runoff hydrographs resulting from the 50-, and 100-year, 24-hour rainfalls. This method, which is an approved hydrologic analysis method listed in the Bridge Design Manual, uses the SCS unit hydrograph (representing the runoff resulting from 1 inch of excess precipitation), synthetic rainfall distribution curve (specifying the distribution of rainfall throughout the storm duration), and the following variables:

- Watershed Area;
- Rainfall depth;
- Runoff Curve Number (measure of the land's capacity to retain precipitation, based on soil and land cover characteristics); and
- Time of Concentration (time required for runoff to travel from the most hydraulically distant point of a watershed to its outlet).

B. Watershed Delineation

The main tributary to North Mill Pond is Hodgson Brook, which enters the southwest end of the pond at the outlet of a stone masonry box culvert beneath Bartlett Street. North Mill Pond also receives runoff from areas immediately north and south of the pond which drain directly to it, rather than to Hodgson Brook.

The following data was used to delineate the area draining to North Mill Pond at Maplewood Avenue:

- Digital elevation model (DEM) generated from 2011 LiDAR data downloaded from NHGRANIT (note that the 2011 LiDAR data is the most recent dataset which covers the entire watershed – more recent data only covers a portion of the watershed);
- Stormwater infrastructure GIS data (storm drains and drainage structures) provided by James McCarty, GIS Manager for the City of Portsmouth;
- 1-foot resolution color orthophotography captured in 2017 and 6-inch resolution color orthophotography captured in 2010; and
- Google Maps Street View.

The watershed includes a significant amount of commercial, industrial, and residential development which has altered the natural drainage patterns. Due to these alterations, the stormwater infrastructure GIS data provided by the City was invaluable in determining the current drainage pathways and watershed boundary. However, this data does not include all of the closed drainage pipes and structures nor does it contain other drainage information such as roof drain connections and parking garage stormwater infrastructure. Where the stormwater infrastructure GIS data was incomplete, the LiDAR DEM, orthophotography, and Google Maps Street View were used to estimate flow pathways and delineate the watershed boundary.

The area draining to North Mill Pond at Maplewood Avenue was determined to be 2,628 acres (4.11 square miles). The watershed boundary is shown on the attached Watershed Relief Map and Drainage Plan.

C. Rainfall

In accordance with the recommendations in NHDRHC STAP (2014), rainfall depths and distributions at the watershed centroid were obtained from the Northeast Regional Climate Center (NRCC) using their “Extreme Precipitation” web tool (<http://precip.eas.cornell.edu>). Table 1 summarizes the rainfall depths for the analyzed storms and Figure 1 shows the rainfall distribution curves for these events.

Table 1 – NRCC Rainfall Data

Storm Frequency	24-hour Rainfall Depth
50-year	7.39”
100-year	8.86”

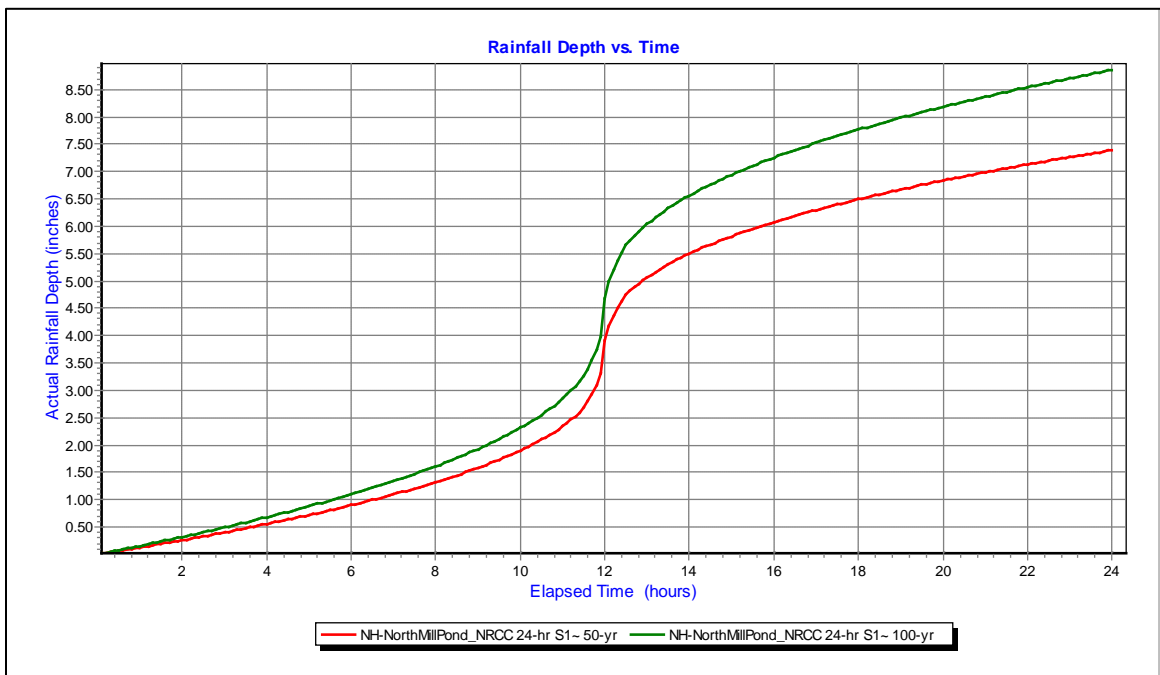

Figure 1 – Rainfall Distribution Curves for 50- and 100-year Storms

D. Runoff Curve Number

The composite runoff curve number (CN) for the watershed was estimated using the following data sources:

- “Impervious Surfaces in the Coastal Watershed of NH and Maine, High Resolution – 2015” GIS layer downloaded from NHGRANIT;
- "Land Use 2015 - Southeastern New Hampshire" GIS layer downloaded from NHGRANIT;
- 1-foot resolution color orthophotography captured in 2017; and

- digital NRCS soil mapping.

The Land Use polygons were clipped to remove those portions covered by the Impervious layer. The remaining portions of the Land Use polygons were then assigned one of the land cover types and conditions listed in Table 2-2 of the SCS Technical Release 55 (TR-55) publication by inspecting the ground cover of these polygons shown on 2017 orthophotography. For example, the orthophotography shows that the Land Use “Electric, gas, and other utilities” polygons, which generally cover utility right-of-ways, support predominantly brush and tall herbaceous vegetation over more than 75 percent of the ground surface, which most closely matches the “Brush, Good” cover type and condition in the TR-55 manual. The attached “North Mill Pond Watershed Land Cover” table summarizes the correlations between the Land Use layers and TR-55 cover types.

Once the land cover mapping was completed for the entire watershed, it was combined with NRCS soil mapping to create soil-land cover polygons for each combination of hydrologic soil group (HSG) and land cover (e.g. Brush, Good, HSG B). Each soil-land cover combination was then assigned a CN from Table 2-2 of the TR-55 manual. The attached “North Mill Pond Watershed Soil – Land Cover Map” shows the soil-land cover polygons and the attached “North Mill Pond Watershed Soil - Land Cover Polygons” table summarizes the areas and CNs for each soil-land cover combination.

This cumulative area of each soil-land cover combination was determined and used to calculate the area-weighted composite CN for the entire watershed. This value was determined to be 73, which suggests a relatively high runoff potential due to the extent of development in the watershed, approximately 36% of which was determined to be covered by impervious surfaces.

E. Time of Concentration

The time of concentration (T_c) – the time for runoff to travel from the hydraulically most distant point of the watershed to the bridge – was estimated using the velocity method. The flow path from the uppermost point of the watershed to the bridge was identified using the DEM and storm drain GIS data and has a total length of 23,320 feet (see attached Drainage Plan). Twenty-six discreet flow segments were delineated – one sheet flow segment and one shallow concentrated flow segment at the upper end of the watershed followed by alternating pipe and channel flow segments as the drainage path crosses multiple roadways on its way to North Mill Pond.

A terrain profile was cut along the flow path and used to identify the start and end of each channel and pipe segment, the invert elevations at these break points, and the length and slope of each segment. The storm drain GIS data included culvert diameter and material attribute information for a few of the pipe runs; however, most of these features did not include this data. For these pipe segments the pipe diameter and material were estimated. A typical cross-section was cut across each channel flow segment and the ground profile from the DEM was used to determine channel geometry for use in calculating travel time. Geometry was measured at an estimated maximum bankfull depth of one foot. The 2017 orthophotography was used to identify land cover along the channel flow segments from which Manning’s roughness coefficients were estimated. Most channel segments have brush or forest cover and were

assigned a roughness coefficient of 0.10. The numerous roadway embankments along the flow path likely have restricted outlets which provide floodwater storage and act to increase Tc and lag time between the start of the runoff event and its peak. Although the analysis did not directly account for the storage effects of these manmade basins, the assignment of relatively high roughness coefficients to the channel flow segments does, to some extent, account for these effects.

The total Tc for the watershed was calculated at 564 minutes (9.4 hours). The attached "North Mill Pond Watershed Time of Concentration" table summarizes the data for each flow segment.

F. Rainfall Runoff Simulation

The hydrologic model yielded the following peak discharges at the Maplewood Avenue Bridge.

Table 2 – Peak Discharge Estimates at Maplewood Avenue

Storm Frequency	Peak Discharge (cfs)
50-year	908
100-year	1,179

Output from the HydroCAD model is attached.

I can be reached at (603) 616-6850 or via email at sean@headwatershydrology.com if you have any questions.

Respectfully submitted,



Sean P. Sweeney, P.E., CWS
Manager
Headwaters Consulting, LLC

Attachments: Watershed Relief Map
 Drainage Plan
 NRCC Precipitation Estimates
 Land Cover Table
 Soil – Land Cover Map
 Soil – Land Cover Polygons Table
 Time of Concentration Table
 HydroCAD Report

Maplewood Avenue over North Mill Pond Watershed Relief Map

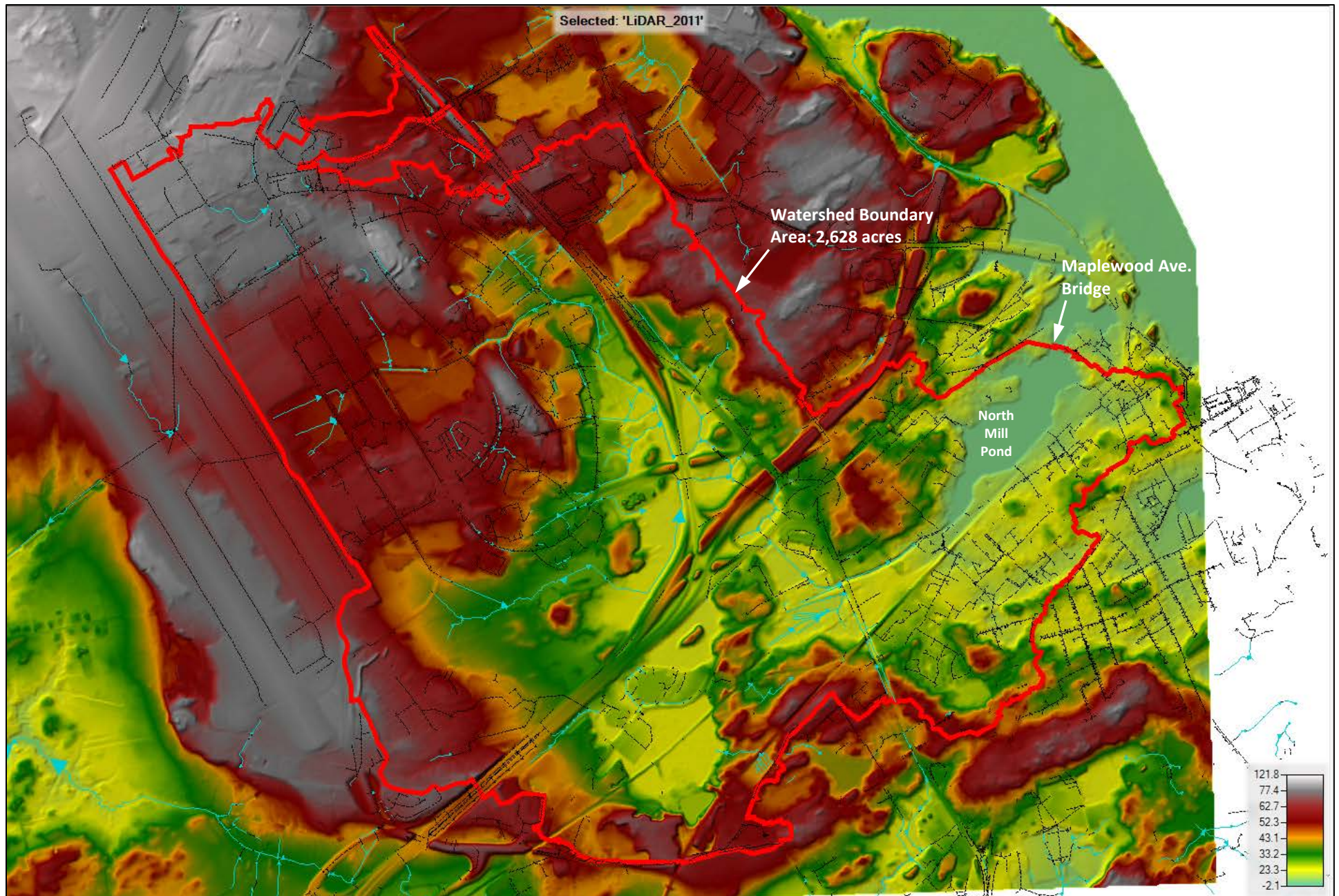



HEADWATERS
Consulting, LLC
P.O. Box 744 Littleton, NH 03561 (603) 616-6850

HOYLE, TANNER & ASSOCIATES, INC.
MAPLEWOOD AVE. OVER NORTH MILL POND BRIDGE REPLACEMENT
PORTSMOUTH, NH
DRAINAGE PLAN

NO.	REVISION	DATE

DATE:	FEB. 2021
PROJECT #:	1920
ENGINEERED BY:	---
DRAWN BY:	SPS

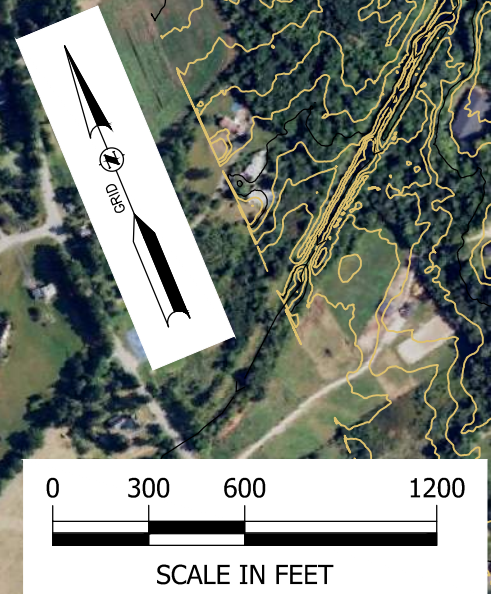

DATE OF PRINT: 02/01/21

C:\Users\sp5\OneDrive\Documents\1920 - HT - Maplewood Ave. Drainage\Map\1920MapHeadwaters.dwg, 2/1/2021 1:38:14 PM

Extreme Precipitation Tables

Northeast Regional Climate Center

Data represents point estimates calculated from partial duration series. All precipitation amounts are displayed in inches.

Smoothing	No
State	New Hampshire
Location	
Longitude	70.792 degrees West
Latitude	43.074 degrees North
Elevation	0 feet
Date/Time	Mon, 01 Feb 2021 08:12:03 -0500

Extreme Precipitation Estimates

	5min	10min	15min	30min	60min	120min		1hr	2hr	3hr	6hr	12hr	24hr	48hr		1day	2day	4day	7day	10day	
1yr	0.26	0.40	0.49	0.66	0.82	1.00	1yr	0.70	0.98	1.14	1.58	2.02	2.66	2.92	1yr	2.35	2.81	3.22	3.94	4.55	1yr
2yr	0.32	0.50	0.61	0.83	1.02	1.21	2yr	0.88	1.18	1.40	1.86	2.41	3.21	3.57	2yr	2.84	3.43	3.93	4.68	5.32	2yr
5yr	0.37	0.57	0.71	0.98	1.24	1.50	5yr	1.07	1.46	1.73	2.32	2.96	4.07	4.57	5yr	3.60	4.40	5.04	5.93	6.70	5yr
10yr	0.42	0.65	0.80	1.12	1.44	1.76	10yr	1.25	1.72	2.04	2.73	3.47	4.87	5.53	10yr	4.31	5.32	6.08	7.10	7.98	10yr
25yr	0.50	0.75	0.94	1.34	1.76	2.18	25yr	1.52	2.13	2.53	3.39	4.27	6.17	7.10	25yr	5.46	6.83	7.79	9.02	10.06	25yr
50yr	0.56	0.85	1.06	1.53	2.06	2.57	50yr	1.78	2.51	2.98	3.99	5.01	7.39	8.58	50yr	6.54	8.25	9.41	10.81	11.99	50yr
100yr	0.64	0.97	1.21	1.75	2.40	3.03	100yr	2.07	2.96	3.51	4.71	5.88	8.86	10.38	100yr	7.84	9.98	11.36	12.96	14.29	100yr
200yr	0.73	1.09	1.38	2.01	2.80	3.57	200yr	2.41	3.49	4.13	5.56	6.89	10.62	12.55	200yr	9.40	12.07	13.72	15.54	17.05	200yr
500yr	0.87	1.29	1.66	2.42	3.44	4.45	500yr	2.97	4.35	5.14	6.92	8.52	13.50	16.15	500yr	11.95	15.53	17.62	19.78	21.54	500yr

Lower Confidence Limits

	5min	10min	15min	30min	60min	120min		1hr	2hr	3hr	6hr	12hr	24hr	48hr		1day	2day	4day	7day	10day	
1yr	0.23	0.36	0.44	0.59	0.73	0.89	1yr	0.63	0.87	0.92	1.32	1.66	2.22	2.52	1yr	1.97	2.42	2.85	3.15	3.88	1yr
2yr	0.31	0.49	0.60	0.81	1.00	1.19	2yr	0.86	1.16	1.37	1.82	2.34	3.05	3.46	2yr	2.70	3.32	3.82	4.55	5.07	2yr
5yr	0.35	0.54	0.67	0.92	1.17	1.40	5yr	1.01	1.37	1.61	2.12	2.74	3.79	4.20	5yr	3.36	4.04	4.72	5.54	6.25	5yr
10yr	0.39	0.59	0.73	1.03	1.32	1.60	10yr	1.14	1.56	1.81	2.40	3.07	4.38	4.89	10yr	3.88	4.70	5.46	6.43	7.22	10yr
25yr	0.44	0.67	0.83	1.19	1.56	1.90	25yr	1.35	1.86	2.10	2.77	3.55	4.69	5.93	25yr	4.15	5.71	6.68	7.83	8.72	25yr
50yr	0.48	0.73	0.91	1.31	1.77	2.17	50yr	1.53	2.12	2.35	3.09	3.96	5.30	6.86	50yr	4.69	6.60	7.78	9.10	10.07	50yr
100yr	0.54	0.81	1.02	1.47	2.01	2.47	100yr	1.74	2.42	2.63	3.44	4.39	5.95	7.94	100yr	5.26	7.63	9.07	10.58	11.62	100yr
200yr	0.59	0.89	1.13	1.64	2.29	2.82	200yr	1.97	2.76	2.94	3.82	4.85	6.65	9.18	200yr	5.89	8.83	10.56	12.32	13.44	200yr
500yr	0.69	1.03	1.32	1.92	2.73	3.37	500yr	2.35	3.30	3.41	4.37	5.54	7.73	11.12	500yr	6.84	10.69	12.92	15.09	16.27	500yr

Upper Confidence Limits

	5min	10min	15min	30min	60min	120min		1hr	2hr	3hr	6hr	12hr	24hr	48hr		1day	2day	4day	7day	10day	
1yr	0.28	0.44	0.54	0.72	0.89	1.08	1yr	0.77	1.06	1.26	1.75	2.21	3.00	3.14	1yr	2.65	3.02	3.58	4.38	5.05	1yr
2yr	0.33	0.52	0.64	0.86	1.06	1.26	2yr	0.92	1.24	1.48	1.96	2.51	3.43	3.69	2yr	3.04	3.55	4.07	4.83	5.64	2yr
5yr	0.40	0.61	0.76	1.05	1.33	1.61	5yr	1.15	1.58	1.88	2.53	3.24	4.34	4.94	5yr	3.84	4.75	5.37	6.35	7.13	5yr
10yr	0.47	0.72	0.89	1.24	1.60	1.97	10yr	1.38	1.92	2.27	3.10	3.93	5.34	6.17	10yr	4.72	5.93	6.77	7.81	8.72	10yr
25yr	0.57	0.87	1.08	1.54	2.03	2.55	25yr	1.75	2.50	2.94	4.05	5.11	7.81	8.28	25yr	6.92	7.96	9.05	10.28	11.36	25yr
50yr	0.66	1.01	1.26	1.81	2.44	3.10	50yr	2.10	3.03	3.58	4.97	6.25	9.79	10.37	50yr	8.66	9.97	11.29	12.65	13.90	50yr
100yr	0.78	1.18	1.48	2.13	2.93	3.77	100yr	2.53	3.69	4.34	6.11	7.67	12.25	12.97	100yr	10.85	12.48	14.08	15.59	17.01	100yr
200yr	0.91	1.37	1.74	2.52	3.51	4.60	200yr	3.03	4.50	5.30	7.52	9.40	15.38	16.26	200yr	13.61	15.63	17.58	19.21	20.82	200yr
500yr	1.13	1.68	2.16	3.14	4.46	5.96	500yr	3.85	5.83	6.87	9.93	12.33	20.80	21.91	500yr	18.41	21.07	23.59	25.31	27.22	500yr

Powered by ACIS

North Mill Pond Watershed Land Cover

categories from NHGRANIT "Land Use 2015 - Southeastern New Hampshire" layer

Note: Impervious areas have been removed from Land Use Category polygons such that the Cover Type applies to the land cover of the remaining polygons outside of impervious areas as estimated from 2017 orthophotography.

<u>NHGRANIT Land Use Category</u>	<u>Cover Type</u>	<u>Condition</u>
Brush or transitional between open & forested	Brush	Good
Electric, gas, and other utilities	Brush	Good
Limited & controlled highway right-of-way	Impervious	n/a
Park & ride lot	Impervious	n/a
Road right-of-way	Impervious	n/a
Agricultural land	Meadow	Good
Water	Open Water	n/a
Rail transportation	Railroad Tracks	n/a
Forest land	Woods	Good
Other transportation, communications, and utilities	Woods	Good
Auxilliary transportation	Woods/Grass 10/90	Good
Cemetaries	Woods/Grass 10/90	Good
Communication	Woods/Grass 10/90	Good
Disturbed land	Woods/Grass 10/90	Fair
Other commercial, services, and institutional	Woods/Grass 10/90	Good
Water and wastewater utilities	Woods/Grass 10/90	Good
Air transportation	Woods/Grass 25/75	Good
Commercial wholesale	Woods/Grass 25/75	Good
Government	Woods/Grass 25/75	Good
Institutional	Woods/Grass 25/75	Good
Lodging	Woods/Grass 25/75	Good
Multi-family (4 or more stories)	Woods/Grass 25/75	Good
Other commercial complexes	Woods/Grass 25/75	Good
Outdoor recreation	Woods/Grass 25/75	Good
Parking structure/lot	Woods/Grass 25/75	Good
Commercial retail	Woods/Grass 40/60	Good
Educational	Woods/Grass 40/60	Good
Multi-family (1-3 stories)	Woods/Grass 40/60	Good
Office park	Woods/Grass 40/60	Good
Other agricultural land	Woods/Grass 40/60	Good
Other industrial complexes	Woods/Grass 40/60	Good
Services	Woods/Grass 40/60	Good
Indoor cultural/ public assembly	Woods/Grass 50/50	Good
Industrial	Woods/Grass 50/50	Good
Other residential	Woods/Grass 50/50	Good
Single family/duplex	Woods/Grass 50/50	Good
Vacant land	Woods/Grass 50/50	Good
Wetlands	Woods/Grass 75/25	Good

North Mill Pond Watershed Soil - Land Cover Map

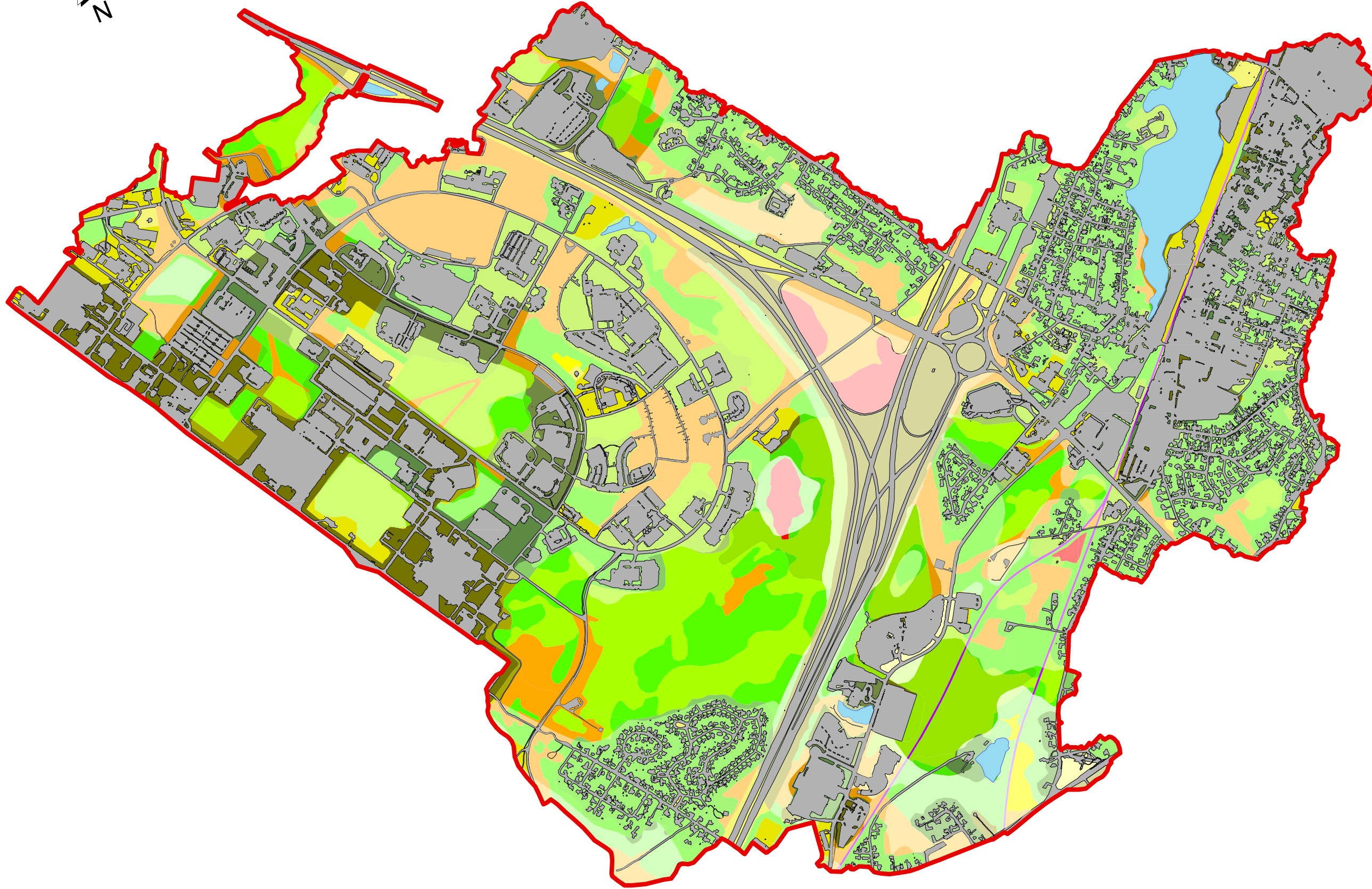

Legend

- WatershedBoundary
- Brush_Good_A
- Brush_Good_B
- Brush_Good_C
- Brush_Good_D
- Impervious
- Meadow_Good_A
- Meadow_Good_B
- Meadow_Good_D
- OpenWater
- RxR_Good_A
- RxR_Good_B
- RxR_Good_C
- RxR_Good_D
- Woods_Good_A
- Woods_Good_B
- Woods_Good_C
- Woods_Good_D
- Woods-Grass_75-25_Good_A
- Woods-Grass_75-25_Good_B
- Woods-Grass_75-25_Good_C
- Woods-Grass_75-25_Good_D
- Woods-Grass_50-50_Good_A
- Woods-Grass_50-50_Good_B
- Woods-Grass_50-50_Good_C
- Woods-Grass_50-50_Good_D
- Woods-Grass_40-60_Good_A
- Woods-Grass_40-60_Good_B
- Woods-Grass_40-60_Good_C
- Woods-Grass_40-60_Good_D
- Woods-Grass_25-75_Good_A
- Woods-Grass_25-75_Good_B
- Woods-Grass_25-75_Good_C
- Woods-Grass_25-75_Good_D
- Woods-Grass_10-90_Fair_A
- Woods-Grass_10-90_Fair_B
- Woods-Grass_10-90_Good_A
- Woods-Grass_10-90_Good_B
- Woods-Grass_10-90_Good_C
- Woods-Grass_10-90_Good_D

0 0.125 0.25 0.5 0.75 1 Miles

North Mill Pond Watershed Soil-Land Cover Polygons

Land Cover	Hydrologic			CN
	Condition	HSG	Area (AC)	
Brush	Good	A	58.81	30
Brush	Good	B	179.13	48
Brush	Good	C	32.85	65
Brush	Good	D	20.82	73
Impervious	n/a		930.36	98
Impervious2	n/a		5.67	98
Meadow	Good	A	23.27	30
Meadow	Good	B	1.73	58
Meadow	Good	C	0.00	71
Meadow	Good	D	0.12	78
Open Water	n/a		54.48	100
RxR	Good	A	1.28	76
RxR	Good	B	5.93	85
RxR	Good	C	0.20	89
RxR	Good	D	1.60	91
Woods	Good	A	60.28	30
Woods	Good	B	120.30	55
Woods	Good	C	80.53	70
Woods	Good	D	17.09	77
Woods-Grass 10-90	Fair	A	5.94	48
Woods-Grass 10-90	Fair	B	1.08	68
Woods-Grass 10-90	Fair	C	0.00	78
Woods-Grass 10-90	Fair	D	0.00	84
Woods-Grass 10-90	Good	A	69.10	38
Woods-Grass 10-90	Good	B	33.81	60
Woods-Grass 10-90	Good	C	2.13	74
Woods-Grass 10-90	Good	D	3.07	80
Woods-Grass 25-75	Good	A	5.89	36
Woods-Grass 25-75	Good	B	55.58	60
Woods-Grass 25-75	Good	C	10.22	73
Woods-Grass 25-75	Good	D	70.08	79
Woods-Grass 40-60	Good	A	5.06	33
Woods-Grass 40-60	Good	B	120.91	59
Woods-Grass 40-60	Good	C	7.04	72
Woods-Grass 40-60	Good	D	38.94	79
Woods-Grass 50-50	Good	A	16.68	32
Woods-Grass 50-50	Good	B	250.09	58
Woods-Grass 50-50	Good	C	7.28	72
Woods-Grass 50-50	Good	D	24.38	79
Woods-Grass 75-25	Good	A	16.01	30
Woods-Grass 75-25	Good	B	94.23	57
Woods-Grass 75-25	Good	C	120.21	71
Woods-Grass 75-25	Good	D	76.21	78

2628.4

Surface Description	Curve Number - Good Condition			
	A	B	C	D
Open Water	100	100	100	100
Impervious	98	98	98	98
Railroad Tracks	76	85	89	91
Grass	39	61	74	80
Meadow	30	58	71	78
Brush	30	48	65	73
Woods/Grass 10/90	38	60	74	80
Woods/Grass 25/75	36	60	73	79
Woods/Grass 40/60	33	59	72	79
Woods/Grass 50/50	32	58	72	79
Woods/Grass 60/40	31	57	72	78
Woods/Grass 75/25	30	57	71	78
Woods	30	55	70	77

Note: CN values are for "good" hydrologic condition (>75% ground cover)

Surface Description	Curve Number - Fair Condition			
	A	B	C	D
Open Water	100	100	100	100
Impervious	98	98	98	98
Railroad Tracks	76	85	89	91
Grass	49	69	79	84
Meadow	30	58	71	78
Brush	35	56	70	77
Woods/Grass 10/90	48	68	78	84
Woods/Grass 25/75	46	67	78	83
Woods/Grass 40/60	44	65	77	82
Woods/Grass 50/50	43	65	76	82
Woods/Grass 60/40	41	64	75	81
Woods/Grass 75/25	39	62	75	80
Woods	36	60	73	79

Note: CN values are for "fair" hydrologic condition (50-75% ground cover)

North Mill Pond Watershed Time of Concentration

Flow Path Segment	Type	Start Sta	Inv In	End Sta	Inv Out	Dia	A	P	Length	Slope	Surface	Notes
1	sheet	0	97.28	73	96.31	-	-	-	73	0.01329	Pavement	
2	shallow	73	96.31	478	92.55	-	-	-	405	0.00928	Grass	
3	pipe	478	88.55	2389	81.02	15	-	-	1911	0.00394	RCP	pipe size & material estimated and inv in estimated at 4' below ground elevation at grate
4	channel	2389	81.02	3584	75.09	-	41	74	1195	0.00496	Forest	A & P measured at typical section at max depth of 1' (estimated bankfull stage)
5	pipe	3584	75.09	3991	71.71	26	-	-	407	0.00831	RCP	pipe slope estimated as average slope between inlet segment 5 and outlet segment 7
6	pipe	3991	71.71	5936	55.54	36	-	-	1945	0.00831	RCP	pipe slope estimated as average slope between inlet segment 5 and outlet segment 7
7	pipe	5936	55.54	7933	38.95	48	-	-	1997	0.00831	RCP	pipe slope estimated as average slope between inlet segment 5 and outlet segment 7
8	channel	7933	38.95	8243	37.04	-	57	123	310	0.00616	Brush	A & P measured at typical section at max depth of 0.87' (elev. Difference between thalwet & height of land in right overbank)
9	pipe	8243	37.04	8344	37.00	60	-	-	101	0.00040	RCP	pipe size & material estimated
10	channel	8344	37.00	9090	34.40	-	148	210	746	0.00349	Brush	A & P measured at typical section at max depth of 1' (estimated bankfull stage)
11	pipe	9090	34.40	9189	33.76	60	-	-	99	0.00646	RCP	pipe size & material estimated
12	channel	9189	33.76	13125	19.25	-	15	27	3936	0.00369	Brush/Forest	A & P measured at typical section at max depth of 1' (estimated bankfull stage)
13	pipe	13125	19.25	13346	18.58	72	-	-	221	0.00303	RCP	pipe size & material estimated
14	channel	13346	18.58	13858	18.14	-	17	26	512	0.00086	Brush/Forest	A & P measured at typical section at max depth of 1' (estimated bankfull stage)
15	pipe	13858	18.14	14194	17.39	72	-	-	336	0.00223	RCP	pipe size & material estimated
16	channel	14194	17.39	14550	17.04	-	18	29	356	0.00098	Brush/Forest	A & P measured at typical section at max depth of 1' (estimated bankfull stage)
17	pipe	14550	17.04	15234	16.40	96	-	-	684	0.00094	CMP	pipe size & material estimated
18	channel	15234	16.40	15909	15.47	-	17	26	675	0.00138	Brush/Forest	A & P measured at typical section at max depth of 1' (estimated bankfull stage)
19	pipe	15909	15.47	16084	15.41	96	-	-	175	0.00034	CMP	pipe size & material estimated
20	channel	16084	15.41	16960	15.35	-	21	32	876	0.00007	Brush/Forest	A & P measured at typical section at max depth of 1' (estimated bankfull stage)
21	pipe	16960	15.35	17041	15.32	96	-	-	81	0.00037	CMP	pipe size & material estimated
22	channel	17041	15.32	17622	15.31	-	13	22	581	0.00002	Forest	A & P measured at typical section at max depth of 1' (estimated bankfull stage)
23	pipe	17622	15.31	17712	13.54	96	-	-	90	0.01967	CMP	pipe size & material estimated
24	channel	17712	13.54	18977	5.58	-	16	23	1265	0.00629	Forest	A & P measured at typical section at max depth of 1' (estimated bankfull stage)
25	pipe	18977	5.58	19479	3.54	72Hx144W	-	-	502	0.00406	Concrete Box	pipe size & material from field measurements
26	channel	19479	1.05	23320	-3.40	-	32	34	3841	0.00116	Cobble/Gravel	channel inverts from field measurments, channel geometry estimated from aerial photography and are based on a channel bottom width of 30', 2:1 side slopes, and flow depth of 1'

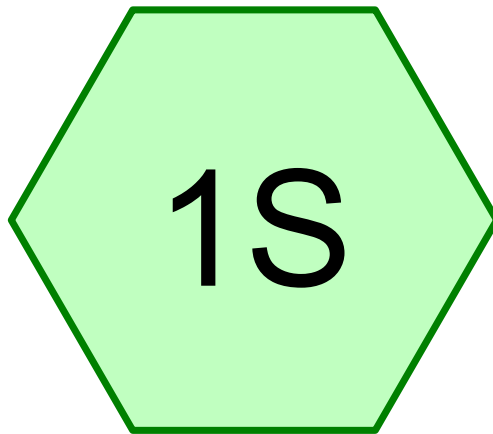

North Mill Pond Watershed

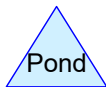
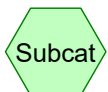

Routing Diagram for NorthMillPond

Prepared by Headwaters Consulting, LLC, Printed 2/1/2021
HydroCAD® 10.10-4b s/n 05301 © 2020 HydroCAD Software Solutions LLC

NorthMillPond

Prepared by Headwaters Consulting, LLC

HydroCAD® 10.10-4b s/n 05301 © 2020 HydroCAD Software Solutions LLC

Printed 2/1/2021

Page 2

Rainfall Events Listing (selected events)

Event#	Event Name	Storm Type	Curve	Mode	Duration (hours)	B/B	Depth (inches)	AMC
1	50-yr	NH-NorthMillPond_NRCC 24-hr S1	50-yr	Default	24.00	1	7.39	2
2	100-yr	NH-NorthMillPond_NRCC 24-hr S1	100-yr	Default	24.00	1	8.86	2

NorthMillPond

Prepared by Headwaters Consulting, LLC
HydroCAD® 10.10-4b s/n 05301 © 2020 HydroCAD Software Solutions LLC

Printed 2/1/2021
Page 3

Area Listing (selected nodes)

Area (acres)	CN	Description (subcatchment-numbers)
1	76	Ballasted RxR Tracks, HSG A (1S)
6	85	Ballasted RxR Tracks, HSG B (1S)
0	89	Ballasted RxR Tracks, HSG C (1S)
2	91	Ballasted RxR Tracks, HSG D (1S)
59	30	Brush, Good, HSG A (1S)
179	48	Brush, Good, HSG B (1S)
33	65	Brush, Good, HSG C (1S)
21	73	Brush, Good, HSG D (1S)
936	98	Impervious (1S)
23	30	Meadow, non-grazed, HSG A (1S)
2	58	Meadow, non-grazed, HSG B (1S)
0	78	Meadow, non-grazed, HSG D (1S)
54	100	Open Water (1S)
60	30	Woods, Good, HSG A (1S)
120	55	Woods, Good, HSG B (1S)
80	70	Woods, Good, HSG C (1S)
17	77	Woods, Good, HSG D (1S)
6	48	Woods/grass 10/90, Fair, HSG A (1S)
1	68	Woods/grass 10/90, Fair, HSG B (1S)
69	38	Woods/grass 10/90, Good, HSG A (1S)
34	60	Woods/grass 10/90, Good, HSG B (1S)
2	74	Woods/grass 10/90, Good, HSG C (1S)
3	80	Woods/grass 10/90, Good, HSG D (1S)
6	36	Woods/grass 25/75, Good, HSG A (1S)
56	60	Woods/grass 25/75, Good, HSG B (1S)
10	73	Woods/grass 25/75, Good, HSG C (1S)
70	79	Woods/grass 25/75, Good, HSG D (1S)
5	33	Woods/grass 40/60, Good, HSG A (1S)
121	59	Woods/grass 40/60, Good, HSG B (1S)
7	72	Woods/grass 40/60, Good, HSG C (1S)
39	79	Woods/grass 40/60, Good, HSG D (1S)
17	32	Woods/grass 50/50, Good, HSG A (1S)
250	58	Woods/grass 50/50, Good, HSG B (1S)
7	72	Woods/grass 50/50, Good, HSG C (1S)
24	79	Woods/grass 50/50, Good, HSG D (1S)
16	30	Woods/grass 75/25, Good, HSG A (1S)
94	57	Woods/grass 75/25, Good, HSG B (1S)
120	71	Woods/grass 75/25, Good, HSG C (1S)
76	78	Woods/grass 75/25, Good, HSG D (1S)
2,628	73	TOTAL AREA

NorthMillPond

Prepared by Headwaters Consulting, LLC

HydroCAD® 10.10-4b s/n 05301 © 2020 HydroCAD Software Solutions LLC

Printed 2/1/2021

Page 4

Soil Listing (selected nodes)

Area (acres)	Soil Group	Subcatchment Numbers
262	HSG A	1S
863	HSG B	1S
260	HSG C	1S
252	HSG D	1S
991	Other	1S
2,628		TOTAL AREA

NorthMillPond

Prepared by Headwaters Consulting, LLC

HydroCAD® 10.10-4b s/n 05301 © 2020 HydroCAD Software Solutions LLC

Printed 2/1/2021

Page 5

Ground Covers (selected nodes)

HSG-A (acres)	HSG-B (acres)	HSG-C (acres)	HSG-D (acres)	Other (acres)	Total (acres)	Ground Cover	Subcatchment Numbers
1	6	0	2	0	9	Ballasted RxR Tracks	1S
59	179	33	21	0	292	Brush, Good	1S
0	0	0	0	936	936	Impervious	1S
23	2	0	0	0	25	Meadow, non-grazed	1S
0	0	0	0	54	54	Open Water	1S
60	120	80	17	0	278	Woods, Good	1S
6	1	0	0	0	7	Woods/grass 10/90, Fair	1S
69	34	2	3	0	108	Woods/grass 10/90, Good	1S
6	56	10	70	0	142	Woods/grass 25/75, Good	1S
5	121	7	39	0	172	Woods/grass 40/60, Good	1S
17	250	7	24	0	299	Woods/grass 50/50, Good	1S
16	94	120	76	0	307	Woods/grass 75/25, Good	1S
262	863	260	252	991	2,628	TOTAL AREA	

NorthMillPond

Prepared by Headwaters Consulting, LLC

Printed 2/1/2021

HydroCAD® 10.10-4b s/n 05301 © 2020 HydroCAD Software Solutions LLC

Page 6

Pipe Listing (selected nodes)

Line#	Node Number	In-Invert (feet)	Out-Invert (feet)	Length (feet)	Slope (ft/ft)	n	Width (inches)	Diam/Height (inches)	Inside-Fill (inches)
1	1S	0.00	0.00	1,911.0	0.0039	0.015	0.0	15.0	0.0
2	1S	0.00	0.00	407.0	0.0083	0.015	0.0	26.0	0.0
3	1S	0.00	0.00	1,945.0	0.0083	0.015	0.0	36.0	0.0
4	1S	0.00	0.00	1,997.0	0.0083	0.015	0.0	48.0	0.0
5	1S	0.00	0.00	101.0	0.0004	0.015	0.0	60.0	0.0
6	1S	0.00	0.00	99.0	0.0065	0.015	0.0	60.0	0.0
7	1S	0.00	0.00	221.0	0.0030	0.015	0.0	72.0	0.0
8	1S	0.00	0.00	336.0	0.0022	0.015	0.0	72.0	0.0
9	1S	0.00	0.00	684.0	0.0009	0.025	0.0	96.0	0.0
10	1S	0.00	0.00	175.0	0.0003	0.025	0.0	96.0	0.0
11	1S	0.00	0.00	81.0	0.0004	0.025	0.0	96.0	0.0
12	1S	0.00	0.00	90.0	0.0197	0.025	0.0	96.0	0.0
13	1S	0.00	0.00	502.0	0.0041	0.015	144.0	72.0	0.0

Summary for Subcatchment 1S: North Mill Pond Watershed

Runoff = 908 cfs @ 19.47 hrs, Volume= 936 af, Depth> 4.27"

Runoff by SCS TR-20 method, UH=SCS, Weighted-CN, Time Span= 6.00-48.00 hrs, dt= 0.05 hrs
 NH-NorthMillPond_NRCC 24-hr S1 50-yr Rainfall=7.39"

Area (ac)	CN	Description
59	30	Brush, Good, HSG A
179	48	Brush, Good, HSG B
33	65	Brush, Good, HSG C
21	73	Brush, Good, HSG D
* 930	98	Impervious
* 6	98	Impervious
23	30	Meadow, non-grazed, HSG A
2	58	Meadow, non-grazed, HSG B
0	78	Meadow, non-grazed, HSG D
* 54	100	Open Water
* 1	76	Ballasted RxR Tracks, HSG A
* 6	85	Ballasted RxR Tracks, HSG B
* 0	89	Ballasted RxR Tracks, HSG C
* 2	91	Ballasted RxR Tracks, HSG D
60	30	Woods, Good, HSG A
120	55	Woods, Good, HSG B
80	70	Woods, Good, HSG C
17	77	Woods, Good, HSG D
* 6	48	Woods/grass 10/90, Fair, HSG A
* 1	68	Woods/grass 10/90, Fair, HSG B
* 69	38	Woods/grass 10/90, Good, HSG A
* 34	60	Woods/grass 10/90, Good, HSG B
* 2	74	Woods/grass 10/90, Good, HSG C
* 3	80	Woods/grass 10/90, Good, HSG D
* 6	36	Woods/grass 25/75, Good, HSG A
* 56	60	Woods/grass 25/75, Good, HSG B
* 10	73	Woods/grass 25/75, Good, HSG C
* 70	79	Woods/grass 25/75, Good, HSG D
* 5	33	Woods/grass 40/60, Good, HSG A
* 121	59	Woods/grass 40/60, Good, HSG B
* 7	72	Woods/grass 40/60, Good, HSG C
* 39	79	Woods/grass 40/60, Good, HSG D
* 17	32	Woods/grass 50/50, Good, HSG A
* 250	58	Woods/grass 50/50, Good, HSG B
* 7	72	Woods/grass 50/50, Good, HSG C
* 24	79	Woods/grass 50/50, Good, HSG D
* 16	30	Woods/grass 75/25, Good, HSG A
* 94	57	Woods/grass 75/25, Good, HSG B
* 120	71	Woods/grass 75/25, Good, HSG C
* 76	78	Woods/grass 75/25, Good, HSG D
2,628	73	Weighted Average
1,638		62.31% Pervious Area
991		37.69% Impervious Area

NorthMillPond

NH-NorthMillPond_NRCC 24-hr S1 50-yr Rainfall=7.39"

Prepared by Headwaters Consulting, LLC

Printed 2/1/2021

HydroCAD® 10.10-4b s/n 05301 © 2020 HydroCAD Software Solutions LLC

Page 8

Tc (min)	Length (feet)	Slope (ft/ft)	Velocity (ft/sec)	Capacity (cfs)	Description
1	73	0.0133	1.12		Sheet Flow, Segment 1 Smooth surfaces n= 0.011 P2= 3.33"
5	405	0.0093	1.45		Shallow Concentrated Flow, Segment 2 Grassed Waterway Kv= 15.0 fps
11	1,911	0.0039	2.85	3.50	Pipe Channel, Segment 3 15.0" Round Area= 1.2 sf Perim= 3.9' r= 0.31' n= 0.015 Concrete sewer w/manholes & inlets
28	1,195	0.0050	0.71	29.06	Channel Flow, Segment 4 Area= 41.0 sf Perim= 74.0' r= 0.55' n= 0.100 Earth, dense brush, high stage
1	407	0.0083	6.00	22.11	Pipe Channel, Segment 5 26.0" Round Area= 3.7 sf Perim= 6.8' r= 0.54' n= 0.015 Concrete sewer w/manholes & inlets
4	1,945	0.0083	7.45	52.66	Pipe Channel, Segment 6 36.0" Round Area= 7.1 sf Perim= 9.4' r= 0.75' n= 0.015 Concrete sewer w/manholes & inlets
4	1,997	0.0083	9.03	113.42	Pipe Channel, Segment 7 48.0" Round Area= 12.6 sf Perim= 12.6' r= 1.00' n= 0.015 Concrete sewer w/manholes & inlets
7	310	0.0062	0.70	39.94	Channel Flow, Segment 8 Area= 57.0 sf Perim= 123.0' r= 0.46' n= 0.100 Earth, dense brush, high stage
1	101	0.0004	2.30	45.14	Pipe Channel, Segment 9 60.0" Round Area= 19.6 sf Perim= 15.7' r= 1.25' n= 0.015 Concrete sewer w/manholes & inlets
18	746	0.0035	0.70	103.04	Channel Flow, Segment 10 Area= 148.0 sf Perim= 210.0' r= 0.70' n= 0.100 Earth, dense brush, high stage
0	99	0.0065	9.27	181.98	Pipe Channel, Segment 11 60.0" Round Area= 19.6 sf Perim= 15.7' r= 1.25' n= 0.015 Concrete sewer w/manholes & inlets
107	3,936	0.0037	0.61	9.16	Channel Flow, Segment 12 Area= 15.0 sf Perim= 27.0' r= 0.56' n= 0.100 Earth, dense brush, high stage
1	221	0.0030	7.11	201.04	Pipe Channel, Segment 13 72.0" Round Area= 28.3 sf Perim= 18.8' r= 1.50' n= 0.015 Concrete sewer w/manholes & inlets
25	512	0.0009	0.34	5.71	Channel Flow, Segment 14 Area= 17.0 sf Perim= 26.0' r= 0.65' n= 0.100 Earth, dense brush, high stage
1	336	0.0022	6.09	172.16	Pipe Channel, Segment 15 72.0" Round Area= 28.3 sf Perim= 18.8' r= 1.50' n= 0.015 Concrete sewer w/manholes & inlets
17	356	0.0010	0.34	6.15	Channel Flow, Segment 16 Area= 18.0 sf Perim= 29.0' r= 0.62' n= 0.100 Earth, dense brush, high stage
4	684	0.0009	2.83	142.28	Pipe Channel, Segment 17 96.0" Round Area= 50.3 sf Perim= 25.1' r= 2.00' n= 0.025 Corrugated metal
27	675	0.0014	0.42	7.12	Channel Flow, Segment 18 Area= 17.0 sf Perim= 26.0' r= 0.65'

NorthMillPond

NH-NorthMillPond_NRCC 24-hr S1 50-yr Rainfall=7.39"

Prepared by Headwaters Consulting, LLC

Printed 2/1/2021

HydroCAD® 10.10-4b s/n 05301 © 2020 HydroCAD Software Solutions LLC

Page 9

n= 0.100 Earth, dense brush, high stage

2	175	0.0003	1.63	82.15	Pipe Channel, Segment 19 96.0" Round Area= 50.3 sf Perim= 25.1' r= 2.00' n= 0.025 Corrugated metal
130	876	0.0001	0.11	2.36	Channel Flow, Segment 20 Area= 21.0 sf Perim= 32.0' r= 0.66' n= 0.100
1	81	0.0004	1.89	94.86	Pipe Channel, Segment 21 96.0" Round Area= 50.3 sf Perim= 25.1' r= 2.00' n= 0.025 Corrugated metal
93	581	0.0001	0.10	1.36	Channel Flow, Segment 22 Area= 13.0 sf Perim= 22.0' r= 0.59' n= 0.100 Earth, dense brush, high stage
0	90	0.0197	13.24	665.68	Pipe Channel, Segment 23 96.0" Round Area= 50.3 sf Perim= 25.1' r= 2.00' n= 0.025 Corrugated metal
23	1,265	0.0063	0.93	14.82	Channel Flow, Segment 24 Area= 16.0 sf Perim= 23.0' r= 0.70' n= 0.100
1	502	0.0041	10.07	725.00	Pipe Channel, Segment 25 144.0" x 72.0" Box Area= 72.0 sf Perim= 36.0' r= 2.00' n= 0.015 Concrete sewer w/manholes & inlets
52	3,841	0.0012	1.24	39.55	Channel Flow, Segment 26 Area= 32.0 sf Perim= 34.0' r= 0.94' n= 0.040 Earth, cobble bottom, clean sides
564 23,320 Total					

Subcatchment 1S: North Mill Pond Watershed

Hydrograph

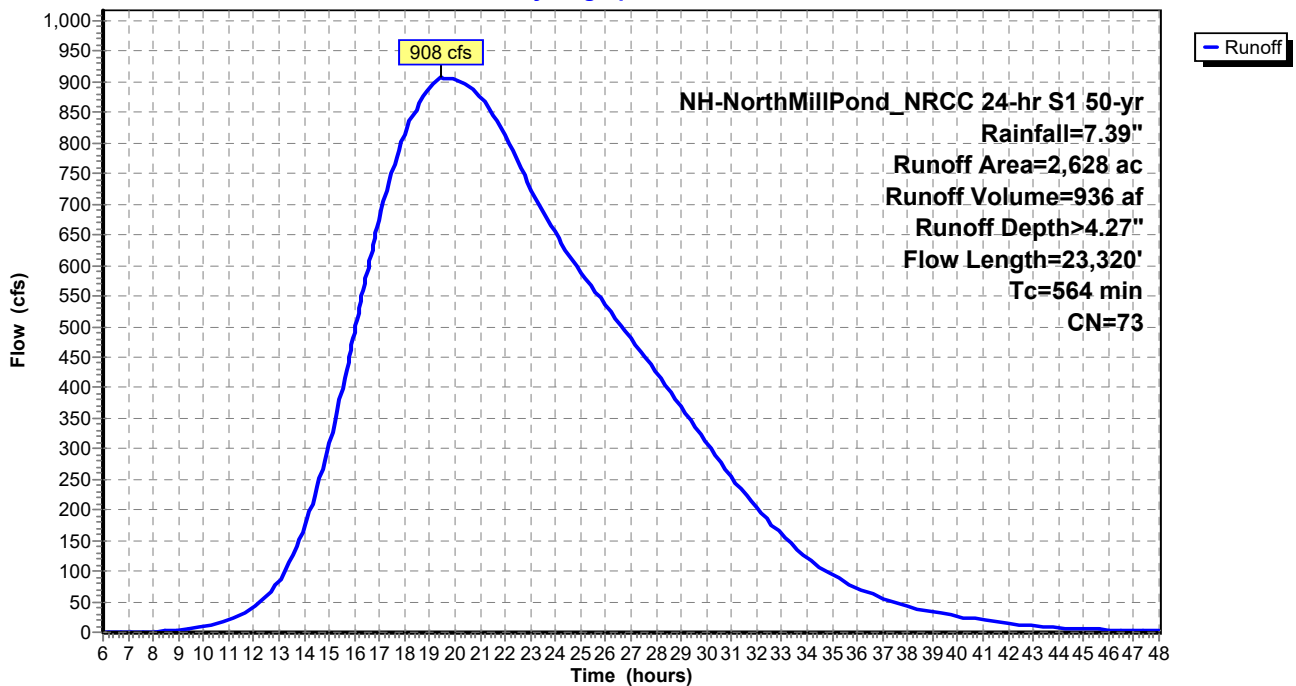

Summary for Subcatchment 1S: North Mill Pond Watershed

Runoff = 1,179 cfs @ 19.46 hrs, Volume= 1,221 af, Depth> 5.58"

Runoff by SCS TR-20 method, UH=SCS, Weighted-CN, Time Span= 6.00-48.00 hrs, dt= 0.05 hrs
 NH-NorthMillPond_NRCC 24-hr S1 100-yr Rainfall=8.86"

Area (ac)	CN	Description
59	30	Brush, Good, HSG A
179	48	Brush, Good, HSG B
33	65	Brush, Good, HSG C
21	73	Brush, Good, HSG D
* 930	98	Impervious
* 6	98	Impervious
23	30	Meadow, non-grazed, HSG A
2	58	Meadow, non-grazed, HSG B
0	78	Meadow, non-grazed, HSG D
* 54	100	Open Water
* 1	76	Ballasted RxR Tracks, HSG A
* 6	85	Ballasted RxR Tracks, HSG B
* 0	89	Ballasted RxR Tracks, HSG C
* 2	91	Ballasted RxR Tracks, HSG D
60	30	Woods, Good, HSG A
120	55	Woods, Good, HSG B
80	70	Woods, Good, HSG C
17	77	Woods, Good, HSG D
* 6	48	Woods/grass 10/90, Fair, HSG A
* 1	68	Woods/grass 10/90, Fair, HSG B
* 69	38	Woods/grass 10/90, Good, HSG A
* 34	60	Woods/grass 10/90, Good, HSG B
* 2	74	Woods/grass 10/90, Good, HSG C
* 3	80	Woods/grass 10/90, Good, HSG D
* 6	36	Woods/grass 25/75, Good, HSG A
* 56	60	Woods/grass 25/75, Good, HSG B
* 10	73	Woods/grass 25/75, Good, HSG C
* 70	79	Woods/grass 25/75, Good, HSG D
* 5	33	Woods/grass 40/60, Good, HSG A
* 121	59	Woods/grass 40/60, Good, HSG B
* 7	72	Woods/grass 40/60, Good, HSG C
* 39	79	Woods/grass 40/60, Good, HSG D
* 17	32	Woods/grass 50/50, Good, HSG A
* 250	58	Woods/grass 50/50, Good, HSG B
* 7	72	Woods/grass 50/50, Good, HSG C
* 24	79	Woods/grass 50/50, Good, HSG D
* 16	30	Woods/grass 75/25, Good, HSG A
* 94	57	Woods/grass 75/25, Good, HSG B
* 120	71	Woods/grass 75/25, Good, HSG C
* 76	78	Woods/grass 75/25, Good, HSG D
2,628	73	Weighted Average
1,638		62.31% Pervious Area
991		37.69% Impervious Area

NorthMillPond

NH-NorthMillPond_NRCC 24-hr S1 100-yr Rainfall=8.86"

Prepared by Headwaters Consulting, LLC

Printed 2/1/2021

HydroCAD® 10.10-4b s/n 05301 © 2020 HydroCAD Software Solutions LLC

Page 11

Tc (min)	Length (feet)	Slope (ft/ft)	Velocity (ft/sec)	Capacity (cfs)	Description
1	73	0.0133	1.12		Sheet Flow, Segment 1 Smooth surfaces n= 0.011 P2= 3.33"
5	405	0.0093	1.45		Shallow Concentrated Flow, Segment 2 Grassed Waterway Kv= 15.0 fps
11	1,911	0.0039	2.85	3.50	Pipe Channel, Segment 3 15.0" Round Area= 1.2 sf Perim= 3.9' r= 0.31' n= 0.015 Concrete sewer w/manholes & inlets
28	1,195	0.0050	0.71	29.06	Channel Flow, Segment 4 Area= 41.0 sf Perim= 74.0' r= 0.55' n= 0.100 Earth, dense brush, high stage
1	407	0.0083	6.00	22.11	Pipe Channel, Segment 5 26.0" Round Area= 3.7 sf Perim= 6.8' r= 0.54' n= 0.015 Concrete sewer w/manholes & inlets
4	1,945	0.0083	7.45	52.66	Pipe Channel, Segment 6 36.0" Round Area= 7.1 sf Perim= 9.4' r= 0.75' n= 0.015 Concrete sewer w/manholes & inlets
4	1,997	0.0083	9.03	113.42	Pipe Channel, Segment 7 48.0" Round Area= 12.6 sf Perim= 12.6' r= 1.00' n= 0.015 Concrete sewer w/manholes & inlets
7	310	0.0062	0.70	39.94	Channel Flow, Segment 8 Area= 57.0 sf Perim= 123.0' r= 0.46' n= 0.100 Earth, dense brush, high stage
1	101	0.0004	2.30	45.14	Pipe Channel, Segment 9 60.0" Round Area= 19.6 sf Perim= 15.7' r= 1.25' n= 0.015 Concrete sewer w/manholes & inlets
18	746	0.0035	0.70	103.04	Channel Flow, Segment 10 Area= 148.0 sf Perim= 210.0' r= 0.70' n= 0.100 Earth, dense brush, high stage
0	99	0.0065	9.27	181.98	Pipe Channel, Segment 11 60.0" Round Area= 19.6 sf Perim= 15.7' r= 1.25' n= 0.015 Concrete sewer w/manholes & inlets
107	3,936	0.0037	0.61	9.16	Channel Flow, Segment 12 Area= 15.0 sf Perim= 27.0' r= 0.56' n= 0.100 Earth, dense brush, high stage
1	221	0.0030	7.11	201.04	Pipe Channel, Segment 13 72.0" Round Area= 28.3 sf Perim= 18.8' r= 1.50' n= 0.015 Concrete sewer w/manholes & inlets
25	512	0.0009	0.34	5.71	Channel Flow, Segment 14 Area= 17.0 sf Perim= 26.0' r= 0.65' n= 0.100 Earth, dense brush, high stage
1	336	0.0022	6.09	172.16	Pipe Channel, Segment 15 72.0" Round Area= 28.3 sf Perim= 18.8' r= 1.50' n= 0.015 Concrete sewer w/manholes & inlets
17	356	0.0010	0.34	6.15	Channel Flow, Segment 16 Area= 18.0 sf Perim= 29.0' r= 0.62' n= 0.100 Earth, dense brush, high stage
4	684	0.0009	2.83	142.28	Pipe Channel, Segment 17 96.0" Round Area= 50.3 sf Perim= 25.1' r= 2.00' n= 0.025 Corrugated metal
27	675	0.0014	0.42	7.12	Channel Flow, Segment 18 Area= 17.0 sf Perim= 26.0' r= 0.65'

NorthMillPond

Prepared by Headwaters Consulting, LLC

HydroCAD® 10.10-4b s/n 05301 © 2020 HydroCAD Software Solutions LLC

NH-NorthMillPond_NRCC 24-hr S1 100-yr Rainfall=8.86"

Printed 2/1/2021

Page 12

n= 0.100 Earth, dense brush, high stage

2	175	0.0003	1.63	82.15	Pipe Channel, Segment 19 96.0" Round Area= 50.3 sf Perim= 25.1' r= 2.00' n= 0.025 Corrugated metal
130	876	0.0001	0.11	2.36	Channel Flow, Segment 20 Area= 21.0 sf Perim= 32.0' r= 0.66' n= 0.100
1	81	0.0004	1.89	94.86	Pipe Channel, Segment 21 96.0" Round Area= 50.3 sf Perim= 25.1' r= 2.00' n= 0.025 Corrugated metal
93	581	0.0001	0.10	1.36	Channel Flow, Segment 22 Area= 13.0 sf Perim= 22.0' r= 0.59' n= 0.100 Earth, dense brush, high stage
0	90	0.0197	13.24	665.68	Pipe Channel, Segment 23 96.0" Round Area= 50.3 sf Perim= 25.1' r= 2.00' n= 0.025 Corrugated metal
23	1,265	0.0063	0.93	14.82	Channel Flow, Segment 24 Area= 16.0 sf Perim= 23.0' r= 0.70' n= 0.100
1	502	0.0041	10.07	725.00	Pipe Channel, Segment 25 144.0" x 72.0" Box Area= 72.0 sf Perim= 36.0' r= 2.00' n= 0.015 Concrete sewer w/manholes & inlets
52	3,841	0.0012	1.24	39.55	Channel Flow, Segment 26 Area= 32.0 sf Perim= 34.0' r= 0.94' n= 0.040 Earth, cobble bottom, clean sides
564 23,320 Total					

Subcatchment 1S: North Mill Pond Watershed

Hydrograph

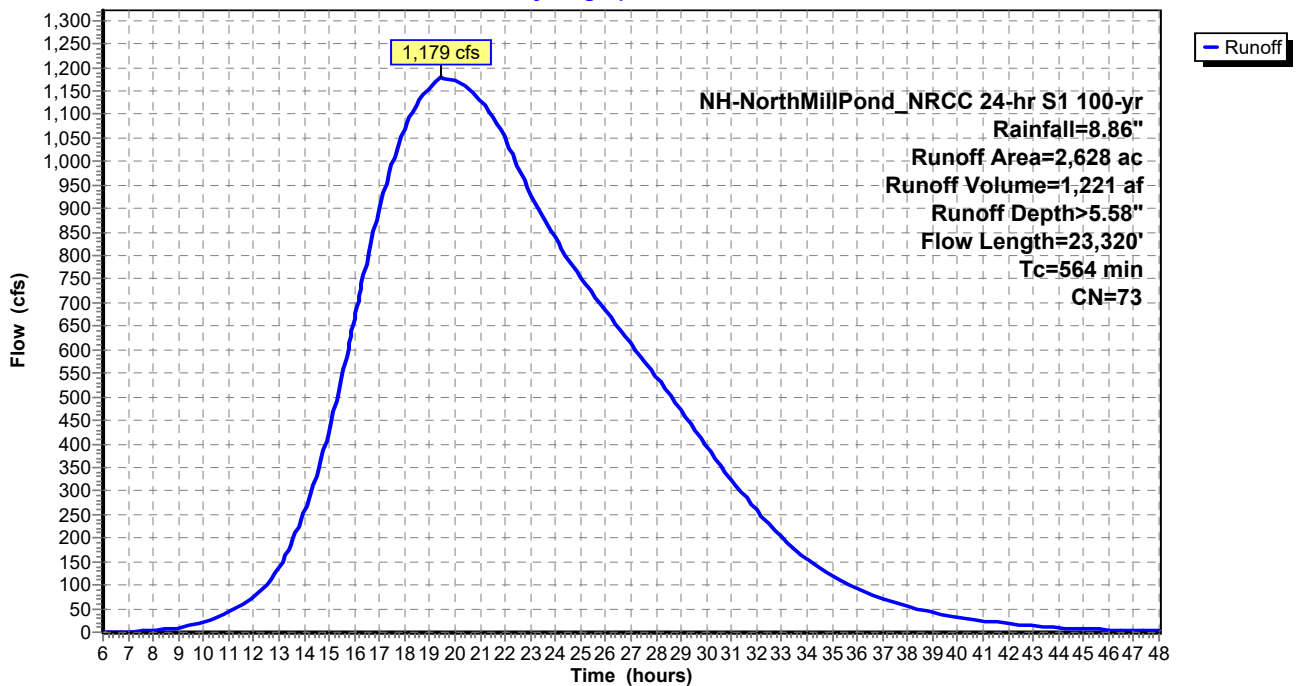

APPENDIX 3
DRAINAGE OUTFALL PROJECT
PRE-PROJECT HYDROLOGY CALCULATIONS

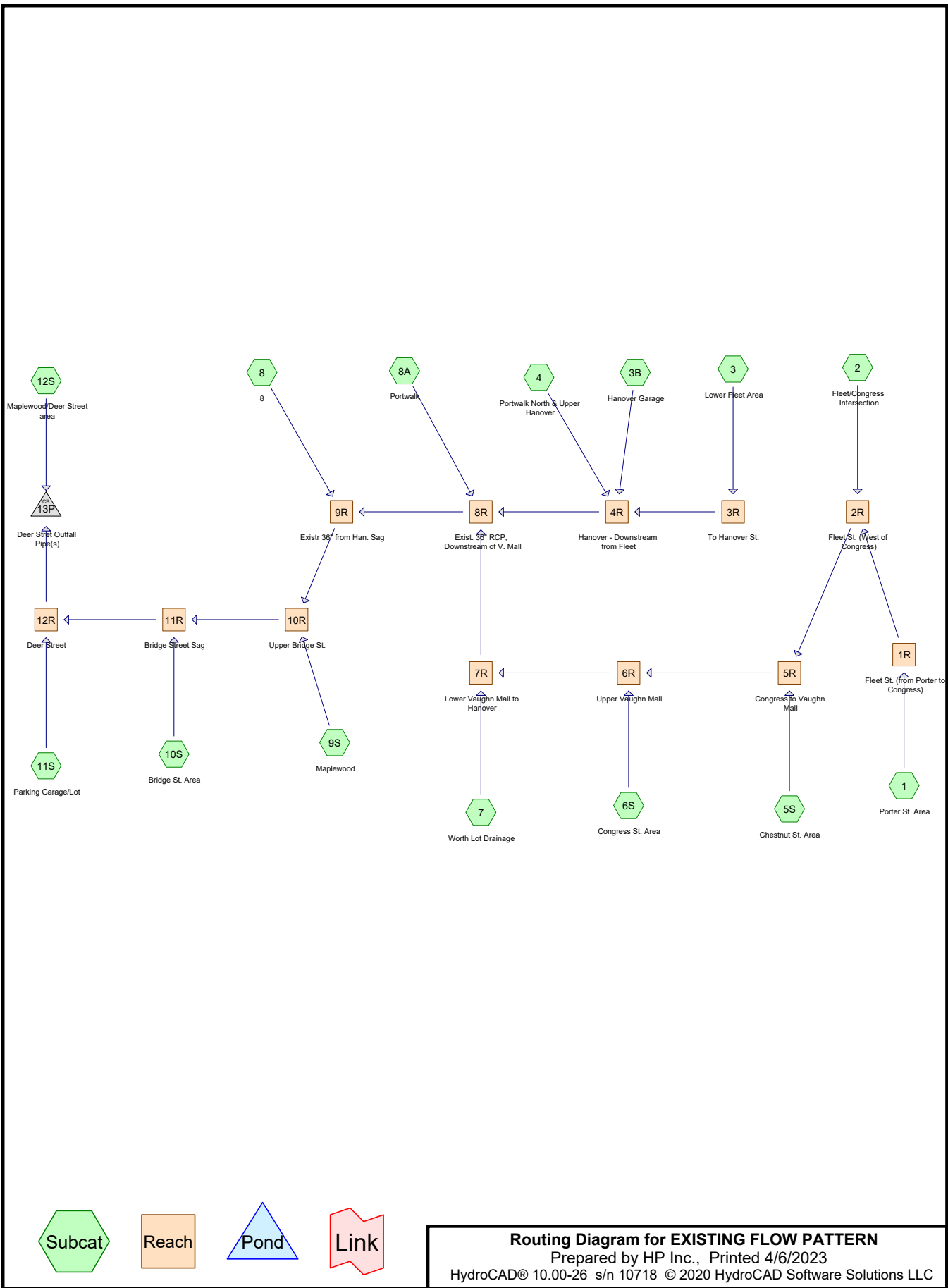

EXISTING FLOW PATTERN

Prepared by HP Inc.

HydroCAD® 10.00-26 s/n 10718 © 2020 HydroCAD Software Solutions LLC

Type III 24-hr Rainfall=5.00"

Printed 4/6/2023

Page 2

Time span=5.00-20.00 hrs, dt=0.05 hrs, 301 points
Runoff by SCS TR-20 method, UH=SCS, Weighted-CN
Reach routing by Stor-Ind+Trans method - Pond routing by Stor-Ind method

Subcatchment1: Porter St. Area

Runoff Area=2.500 ac Runoff Depth>4.06"
Tc=6.0 min CN=94 Runoff=11.47 cfs 0.847 af

Subcatchment2: Fleet/Congress Intersection

Runoff Area=1.100 ac Runoff Depth>4.25"
Tc=6.0 min CN=96 Runoff=5.17 cfs 0.390 af

Subcatchment3: Lower Fleet Area

Runoff Area=1.300 ac Runoff Depth>4.25"
Tc=6.0 min CN=96 Runoff=6.11 cfs 0.461 af

Subcatchment3B: Hanover Garage

Runoff Area=2.700 ac Runoff Depth>4.25"
Tc=6.0 min CN=96 Runoff=12.69 cfs 0.957 af

Subcatchment4: Portwalk North & Upper Hanover

Runoff Area=4.100 ac Runoff Depth>3.86"
Tc=8.0 min CN=92 Runoff=17.23 cfs 1.320 af

Subcatchment5S: Chestnut St. Area

Runoff Area=2.100 ac Runoff Depth>4.06"
Tc=6.0 min CN=94 Runoff=9.63 cfs 0.711 af

Subcatchment6S: Congress St. Area

Runoff Area=1.100 ac Runoff Depth>4.06"
Tc=6.0 min CN=94 Runoff=5.05 cfs 0.373 af

Subcatchment7: Worth Lot Drainage

Runoff Area=1.400 ac Runoff Depth>4.06"
Tc=6.0 min CN=94 Runoff=6.42 cfs 0.474 af

Subcatchment8: 8

Runoff Area=1.800 ac Runoff Depth>4.25"
Tc=6.0 min CN=96 Runoff=8.46 cfs 0.638 af

Subcatchment8A: Portwalk

Runoff Area=1.200 ac Runoff Depth>3.86"
Tc=6.0 min CN=92 Runoff=5.34 cfs 0.386 af

Subcatchment9S: Maplewood

Runoff Area=6.700 ac Runoff Depth>3.46"
Tc=9.0 min CN=88 Runoff=25.08 cfs 1.931 af

Subcatchment10S: Bridge St. Area

Runoff Area=4.500 ac Runoff Depth>3.86"
Tc=6.0 min CN=92 Runoff=20.01 cfs 1.449 af

Subcatchment11S: Parking Garage/Lot

Runoff Area=2.000 ac Runoff Depth>4.06"
Tc=6.0 min CN=94 Runoff=9.17 cfs 0.677 af

Subcatchment12S: Maplewood/Deer Street area

Runoff Area=4.500 ac Runoff Depth>3.07"
Tc=10.0 min CN=84 Runoff=14.80 cfs 1.150 af

Reach 1R: Fleet St. (from Porter to 18.0" Round Pipe Avg. Flow Depth=1.16' Max Vel=7.86 fps Inflow=11.47 cfs 0.847 af
n=0.010 L=180.0' S=0.0080 '/' Capacity=12.21 cfs Outflow=11.30 cfs 0.846 af

Reach 2R: Fleet St. (West of Congress) Avg. Flow Depth=1.67' Max Vel=5.84 fps Inflow=16.44 cfs 1.236 af
24.0" Round Pipe n=0.010 L=200.0' S=0.0030 '/' Capacity=16.11 cfs Outflow=15.95 cfs 1.235 af

EXISTING FLOW PATTERN

Type III 24-hr Rainfall=5.00"

Prepared by HP Inc.

Printed 4/6/2023

HydroCAD® 10.00-26 s/n 10718 © 2020 HydroCAD Software Solutions LLC

Page 3

Reach 3R: To Hanover St.	Avg. Flow Depth=1.06'	Max Vel=5.51 fps	Inflow=6.11 cfs	0.461 af		
15.0" Round Pipe	n=0.010	L=80.0'	S=0.0050 '/'	Capacity=5.94 cfs	Outflow=6.05 cfs	0.461 af
Reach 4R: Hanover - Downstream from	Avg. Flow Depth=1.96'	Max Vel=8.62 fps	Inflow=35.74 cfs	2.738 af		
30.0" Round Pipe	n=0.012	L=180.0'	S=0.0070 '/'	Capacity=37.18 cfs	Outflow=35.13 cfs	2.736 af
Reach 5R: Congress to Vaughn Mall	Avg. Flow Depth=1.50'	Max Vel=10.08 fps	Inflow=25.40 cfs	1.946 af		
24.0" Round Pipe	n=0.012	L=100.0'	S=0.0130 '/'	Capacity=27.94 cfs	Outflow=25.21 cfs	1.946 af
Reach 6R: Upper Vaughn Mall	Avg. Flow Depth=1.60'	Max Vel=11.19 fps	Inflow=30.18 cfs	2.318 af		
24.0" Round Pipe	n=0.010	L=200.0'	S=0.0110 '/'	Capacity=30.84 cfs	Outflow=29.74 cfs	2.318 af
Reach 7R: Lower Vaughn Mall to	Avg. Flow Depth=1.70'	Max Vel=12.61 fps	Inflow=35.99 cfs	2.792 af		
24.0" Round Pipe	n=0.010	L=150.0'	S=0.0140 '/'	Capacity=34.80 cfs	Outflow=35.62 cfs	2.791 af
Reach 8R: Exist. 36" RCP,	Avg. Flow Depth=2.45'	Max Vel=12.22 fps	Inflow=75.93 cfs	5.914 af		
36.0" Round Pipe	n=0.012	L=200.0'	S=0.0110 '/'	Capacity=75.78 cfs	Outflow=74.85 cfs	5.912 af
Reach 9R: Existr 36" from Han. Sag	Avg. Flow Depth=2.57'	Max Vel=12.76 fps	Inflow=82.94 cfs	6.550 af		
36.0" Round Pipe	n=0.012	L=260.0'	S=0.0120 '/'	Capacity=79.15 cfs	Outflow=81.35 cfs	6.548 af
Reach 10R: Upper Bridge St.	Avg. Flow Depth=3.32'	Max Vel=9.50 fps	Inflow=106.28 cfs	8.478 af		
48.0" Round Pipe	n=0.012	L=170.0'	S=0.0045 '/'	Capacity=104.73 cfs	Outflow=105.46 cfs	8.475 af
Reach 11R: Bridge Street Sag	Avg. Flow Depth=3.34'	Max Vel=10.93 fps	Inflow=122.72 cfs	9.925 af		
48.0" Round Pipe	n=0.012	L=160.0'	S=0.0060 '/'	Capacity=120.54 cfs	Outflow=122.01 cfs	9.922 af
Reach 12R: Deer Street	Avg. Flow Depth=3.26'	Max Vel=11.81 fps	Inflow=129.83 cfs	10.599 af		
48.0" Round Pipe	n=0.012	L=160.0'	S=0.0070 '/'	Capacity=130.20 cfs	Outflow=129.15 cfs	10.596 af
Pond 13P: Deer Stret Outfall Pipe(s)	Peak Elev=6.00'	Inflow=143.94 cfs	11.746 af			
48.0" Round Culvert x 2.00	n=0.012	L=575.0'	S=0.0020 '/'	Outflow=143.94 cfs	11.746 af	

EXISTING FLOW PATTERN

Prepared by HP Inc.

HydroCAD® 10.00-26 s/n 10718 © 2020 HydroCAD Software Solutions LLC

Type III 24-hr Rainfall=5.00"

Printed 4/6/2023

Page 4

Summary for Subcatchment 1: Porter St. Area

Runoff = 11.47 cfs @ 12.09 hrs, Volume= 0.847 af, Depth> 4.06"

Runoff by SCS TR-20 method, UH=SCS, Weighted-CN, Time Span= 5.00-20.00 hrs, dt= 0.05 hrs
Type III 24-hr Rainfall=5.00"

Area (ac)	CN	Description
* 2.500	94	Upper Fleet St

Tc (min)	Length (feet)	Slope (ft/ft)	Velocity (ft/sec)	Capacity (cfs)	Description
6.0					Direct Entry,

Subcatchment 1: Porter St. Area

Hydrograph

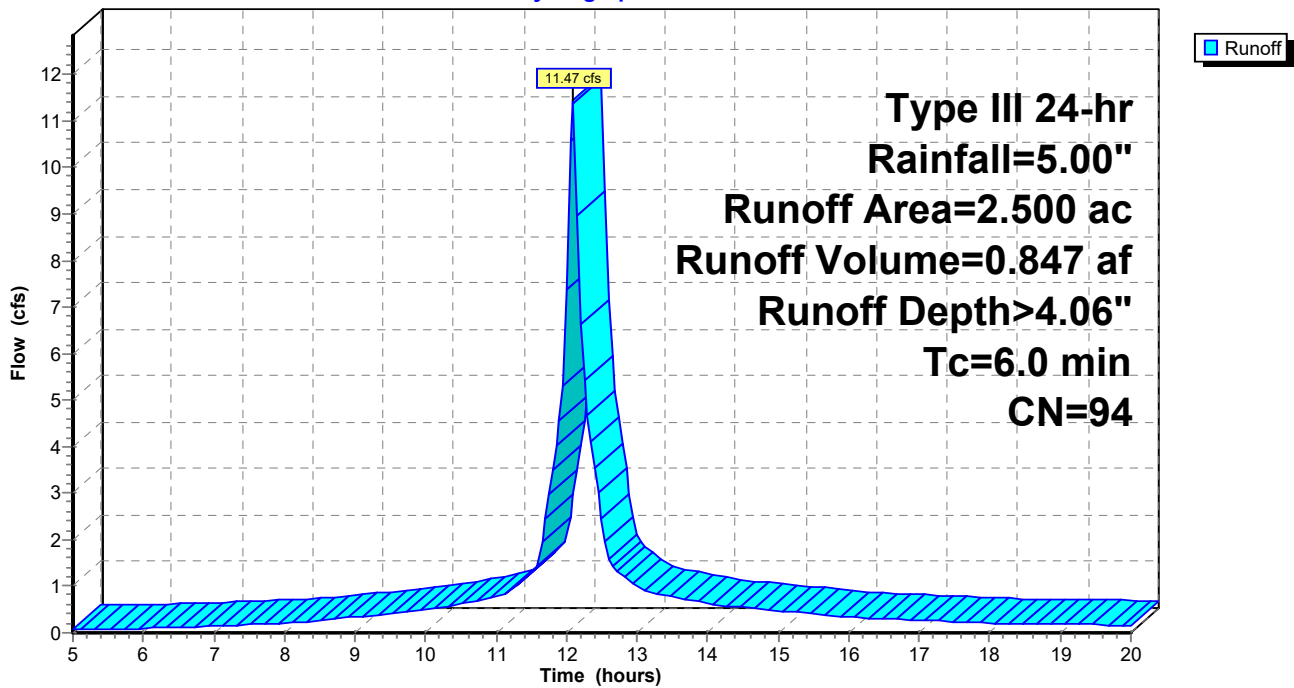

EXISTING FLOW PATTERN

Prepared by HP Inc.

HydroCAD® 10.00-26 s/n 10718 © 2020 HydroCAD Software Solutions LLC

Type III 24-hr Rainfall=5.00"

Printed 4/6/2023

Page 5

Summary for Subcatchment 2: Fleet/Congress Intersection

Runoff = 5.17 cfs @ 12.09 hrs, Volume= 0.390 af, Depth> 4.25"

Runoff by SCS TR-20 method, UH=SCS, Weighted-CN, Time Span= 5.00-20.00 hrs, dt= 0.05 hrs
Type III 24-hr Rainfall=5.00"

Area (ac)	CN	Description
* 1.100	96	

Tc (min)	Length (feet)	Slope (ft/ft)	Velocity (ft/sec)	Capacity (cfs)	Description
6.0					Direct Entry,

Subcatchment 2: Fleet/Congress Intersection

Hydrograph

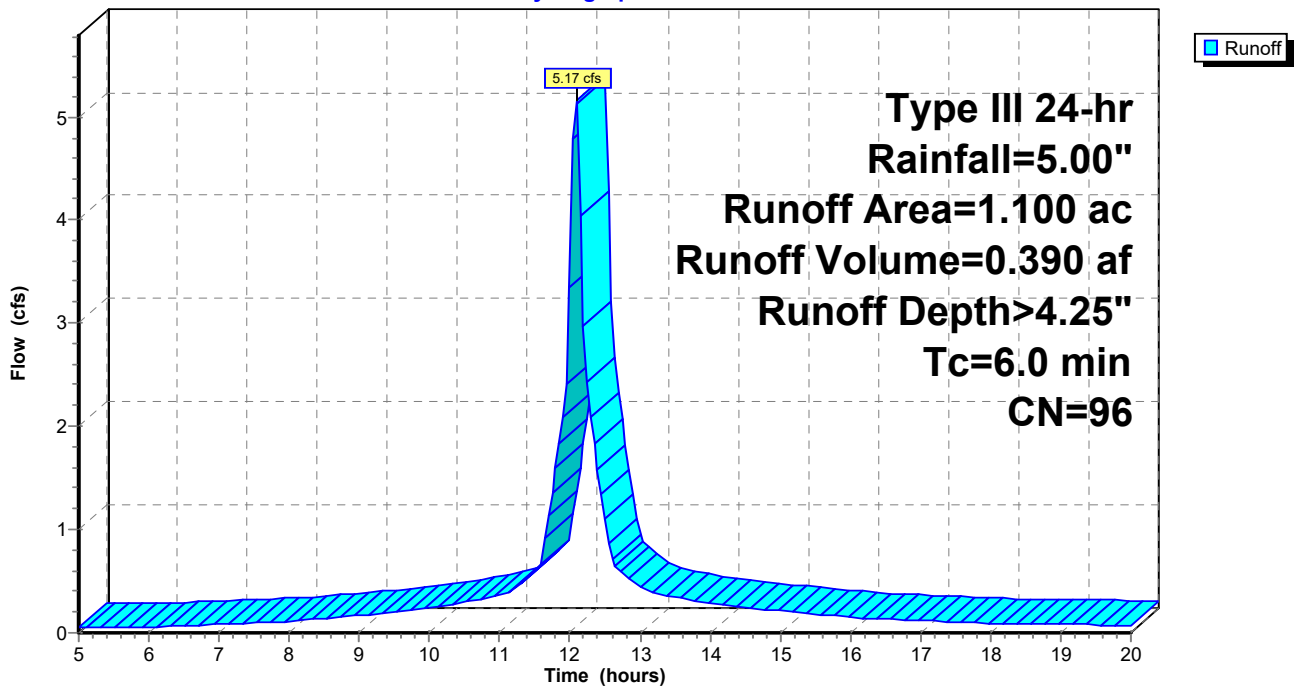

EXISTING FLOW PATTERN

Prepared by HP Inc.

HydroCAD® 10.00-26 s/n 10718 © 2020 HydroCAD Software Solutions LLC

Type III 24-hr Rainfall=5.00"

Printed 4/6/2023

Page 6

Summary for Subcatchment 3: Lower Fleet Area

Runoff = 6.11 cfs @ 12.09 hrs, Volume= 0.461 af, Depth > 4.25"

Runoff by SCS TR-20 method, UH=SCS, Weighted-CN, Time Span= 5.00-20.00 hrs, dt= 0.05 hrs
Type III 24-hr Rainfall=5.00"

Area (ac)	CN	Description
* 1.300	96	

Tc (min)	Length (feet)	Slope (ft/ft)	Velocity (ft/sec)	Capacity (cfs)	Description
6.0					Direct Entry,

Subcatchment 3: Lower Fleet Area

Hydrograph

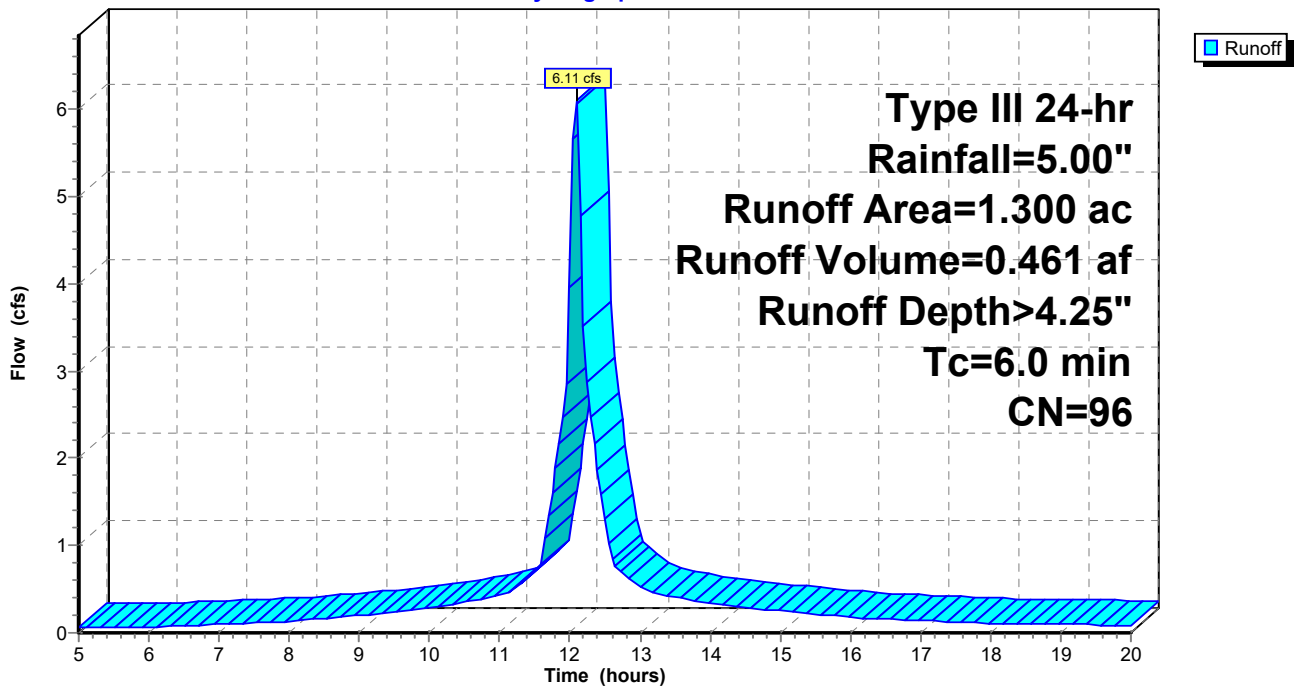

EXISTING FLOW PATTERN

Prepared by HP Inc.

HydroCAD® 10.00-26 s/n 10718 © 2020 HydroCAD Software Solutions LLC

Type III 24-hr Rainfall=5.00"

Printed 4/6/2023

Page 7

Summary for Subcatchment 3B: Hanover Garage

Runoff = 12.69 cfs @ 12.09 hrs, Volume= 0.957 af, Depth> 4.25"

Runoff by SCS TR-20 method, UH=SCS, Weighted-CN, Time Span= 5.00-20.00 hrs, dt= 0.05 hrs
Type III 24-hr Rainfall=5.00"

Area (ac)	CN	Description
* 2.700	96	

Tc (min)	Length (feet)	Slope (ft/ft)	Velocity (ft/sec)	Capacity (cfs)	Description
6.0					Direct Entry, minimum

Subcatchment 3B: Hanover Garage

Hydrograph

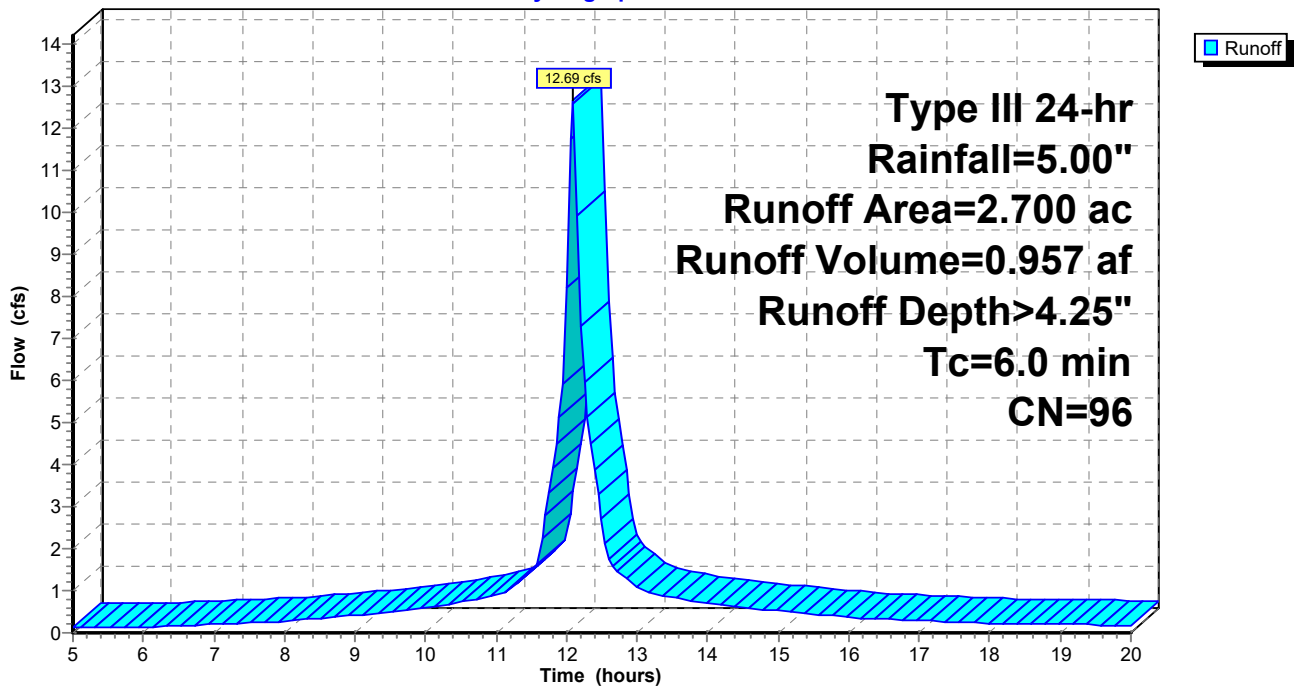

EXISTING FLOW PATTERN

Prepared by HP Inc.

HydroCAD® 10.00-26 s/n 10718 © 2020 HydroCAD Software Solutions LLC

Type III 24-hr Rainfall=5.00"

Printed 4/6/2023

Page 8

Summary for Subcatchment 4: Portwalk North & Upper Hanover

Runoff = 17.23 cfs @ 12.11 hrs, Volume= 1.320 af, Depth> 3.86"

Runoff by SCS TR-20 method, UH=SCS, Weighted-CN, Time Span= 5.00-20.00 hrs, dt= 0.05 hrs
Type III 24-hr Rainfall=5.00"

Area (ac)	CN	Description
* 4.100	92	

Tc (min)	Length (feet)	Slope (ft/ft)	Velocity (ft/sec)	Capacity (cfs)	Description
8.0					Direct Entry,

Subcatchment 4: Portwalk North & Upper Hanover

Hydrograph

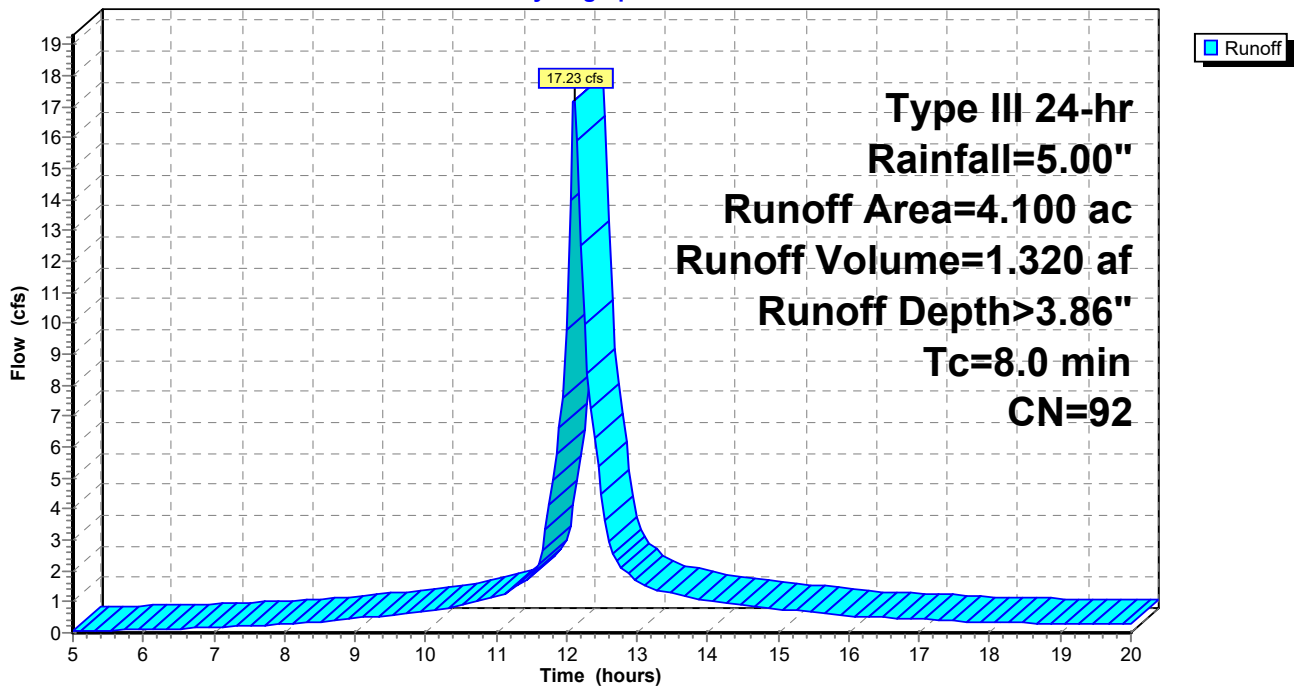

EXISTING FLOW PATTERN

Prepared by HP Inc.

HydroCAD® 10.00-26 s/n 10718 © 2020 HydroCAD Software Solutions LLC

Type III 24-hr Rainfall=5.00"

Printed 4/6/2023

Page 9

Summary for Subcatchment 5S: Chestnut St. Area

Runoff = 9.63 cfs @ 12.09 hrs, Volume= 0.711 af, Depth> 4.06"

Runoff by SCS TR-20 method, UH=SCS, Weighted-CN, Time Span= 5.00-20.00 hrs, dt= 0.05 hrs
Type III 24-hr Rainfall=5.00"

Area (ac)	CN	Description
* 2.100	94	

Tc (min)	Length (feet)	Slope (ft/ft)	Velocity (ft/sec)	Capacity (cfs)	Description
6.0					Direct Entry,

Subcatchment 5S: Chestnut St. Area

Hydrograph

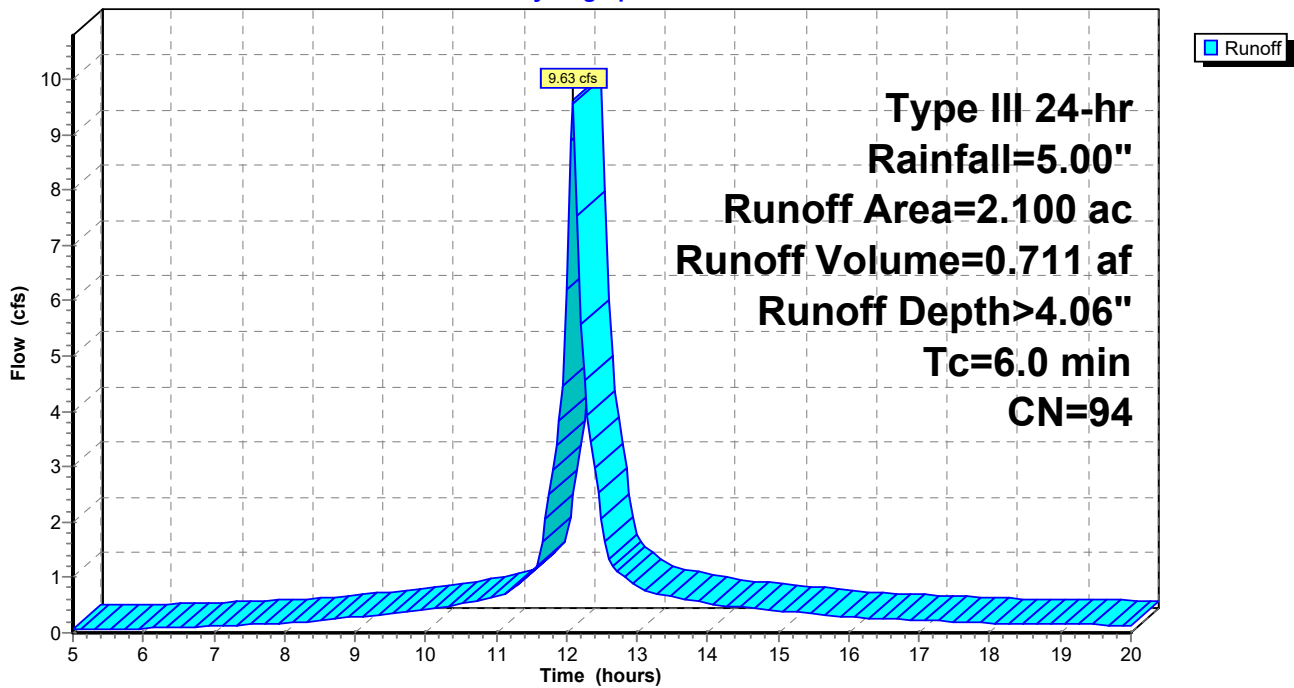

EXISTING FLOW PATTERN

Prepared by HP Inc.

HydroCAD® 10.00-26 s/n 10718 © 2020 HydroCAD Software Solutions LLC

Type III 24-hr Rainfall=5.00"

Printed 4/6/2023

Page 10

Summary for Subcatchment 6S: Congress St. Area

Runoff = 5.05 cfs @ 12.09 hrs, Volume= 0.373 af, Depth> 4.06"

Runoff by SCS TR-20 method, UH=SCS, Weighted-CN, Time Span= 5.00-20.00 hrs, dt= 0.05 hrs
Type III 24-hr Rainfall=5.00"

Area (ac)	CN	Description
* 1.100	94	

Tc (min)	Length (feet)	Slope (ft/ft)	Velocity (ft/sec)	Capacity (cfs)	Description
6.0					Direct Entry,

Subcatchment 6S: Congress St. Area

Hydrograph

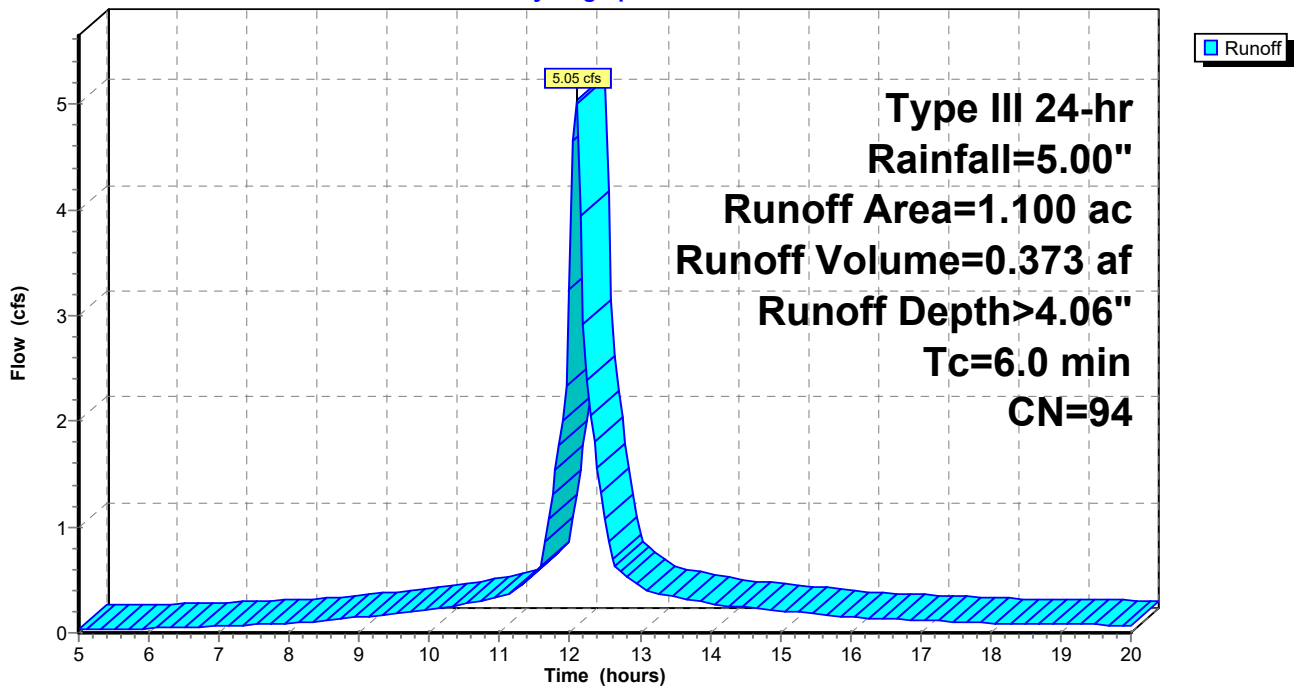

EXISTING FLOW PATTERN

Prepared by HP Inc.

HydroCAD® 10.00-26 s/n 10718 © 2020 HydroCAD Software Solutions LLC

Type III 24-hr Rainfall=5.00"

Printed 4/6/2023

Page 11

Summary for Subcatchment 7: Worth Lot Drainage

Runoff = 6.42 cfs @ 12.09 hrs, Volume= 0.474 af, Depth> 4.06"

Runoff by SCS TR-20 method, UH=SCS, Weighted-CN, Time Span= 5.00-20.00 hrs, dt= 0.05 hrs
Type III 24-hr Rainfall=5.00"

Area (ac)	CN	Description
* 1.400	94	

Tc (min)	Length (feet)	Slope (ft/ft)	Velocity (ft/sec)	Capacity (cfs)	Description
6.0					Direct Entry,

Subcatchment 7: Worth Lot Drainage

Hydrograph

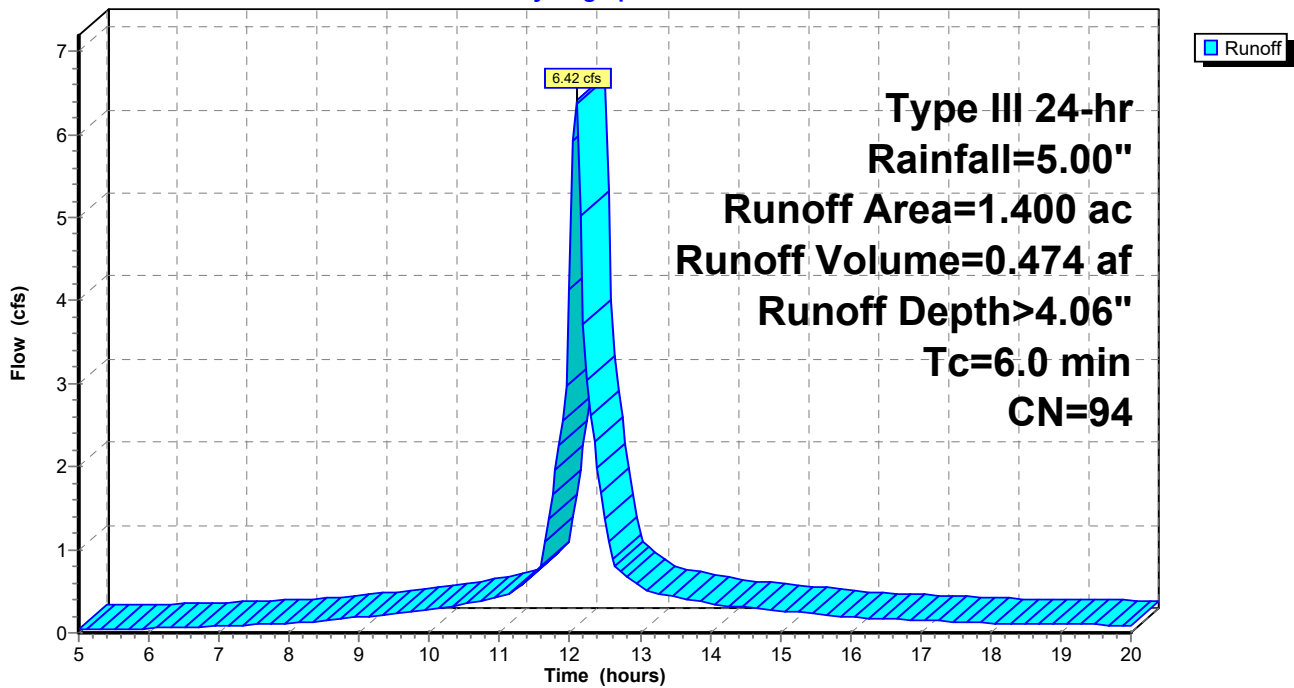

EXISTING FLOW PATTERN

Prepared by HP Inc.

HydroCAD® 10.00-26 s/n 10718 © 2020 HydroCAD Software Solutions LLC

Type III 24-hr Rainfall=5.00"

Printed 4/6/2023

Page 12

Summary for Subcatchment 8: 8

Runoff = 8.46 cfs @ 12.09 hrs, Volume= 0.638 af, Depth> 4.25"

Runoff by SCS TR-20 method, UH=SCS, Weighted-CN, Time Span= 5.00-20.00 hrs, dt= 0.05 hrs
Type III 24-hr Rainfall=5.00"

Area (ac)	CN	Description
* 1.800	96	

Tc (min)	Length (feet)	Slope (ft/ft)	Velocity (ft/sec)	Capacity (cfs)	Description
6.0					Direct Entry,

Subcatchment 8: 8

Hydrograph

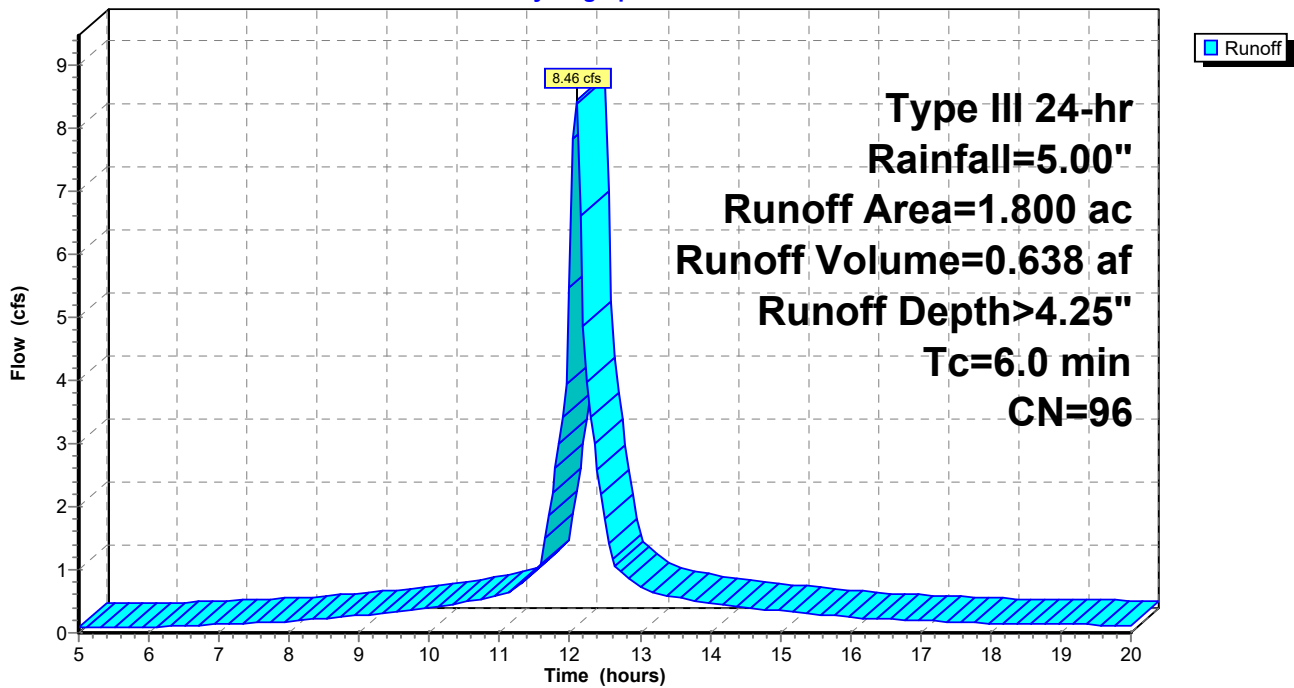

EXISTING FLOW PATTERN

Prepared by HP Inc.

HydroCAD® 10.00-26 s/n 10718 © 2020 HydroCAD Software Solutions LLC

Type III 24-hr Rainfall=5.00"

Printed 4/6/2023

Page 13

Summary for Subcatchment 8A: Portwalk

Runoff = 5.34 cfs @ 12.09 hrs, Volume= 0.386 af, Depth> 3.86"

Runoff by SCS TR-20 method, UH=SCS, Weighted-CN, Time Span= 5.00-20.00 hrs, dt= 0.05 hrs
Type III 24-hr Rainfall=5.00"

Area (ac)	CN	Description
* 1.200	92	

Tc (min)	Length (feet)	Slope (ft/ft)	Velocity (ft/sec)	Capacity (cfs)	Description
6.0					Direct Entry,

Subcatchment 8A: Portwalk

Hydrograph

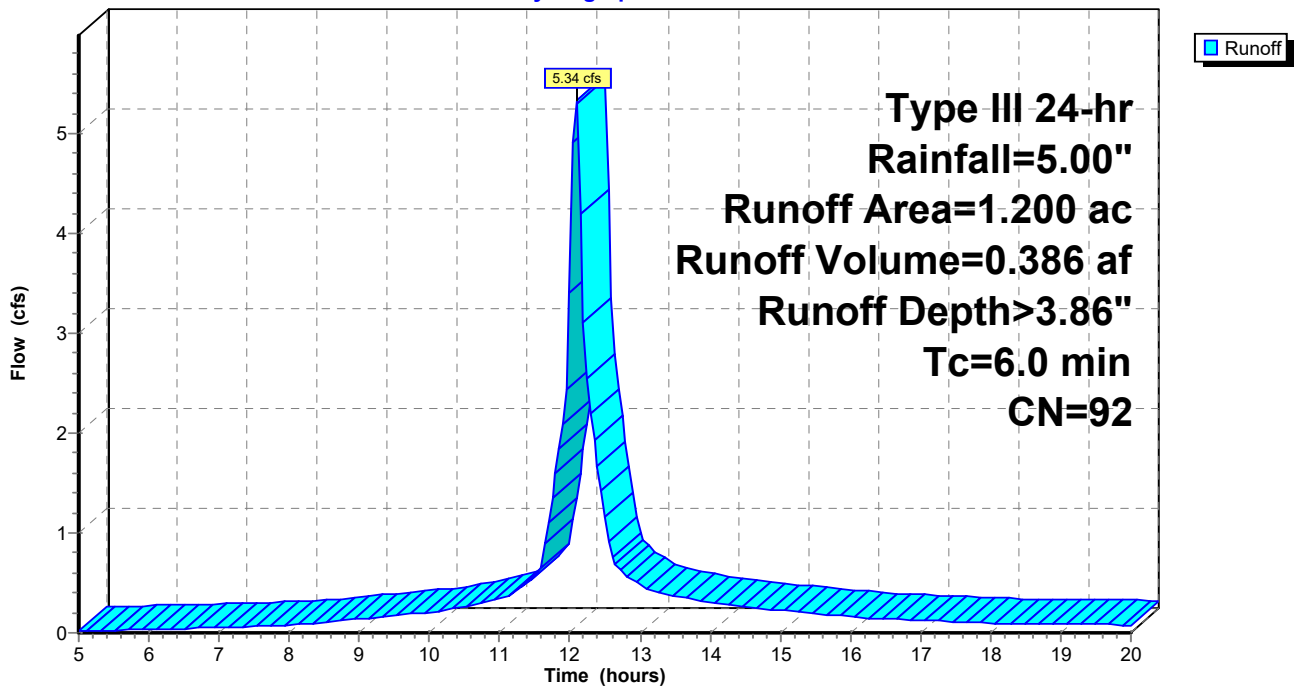

EXISTING FLOW PATTERN

Prepared by HP Inc.

HydroCAD® 10.00-26 s/n 10718 © 2020 HydroCAD Software Solutions LLC

Type III 24-hr Rainfall=5.00"

Printed 4/6/2023

Page 14

Summary for Subcatchment 9S: Maplewood

Runoff = 25.08 cfs @ 12.12 hrs, Volume= 1.931 af, Depth> 3.46"

Runoff by SCS TR-20 method, UH=SCS, Weighted-CN, Time Span= 5.00-20.00 hrs, dt= 0.05 hrs
Type III 24-hr Rainfall=5.00"

Area (ac)	CN	Description
* 6.700	88	

Tc (min)	Length (feet)	Slope (ft/ft)	Velocity (ft/sec)	Capacity (cfs)	Description
9.0					Direct Entry,

Subcatchment 9S: Maplewood

Hydrograph

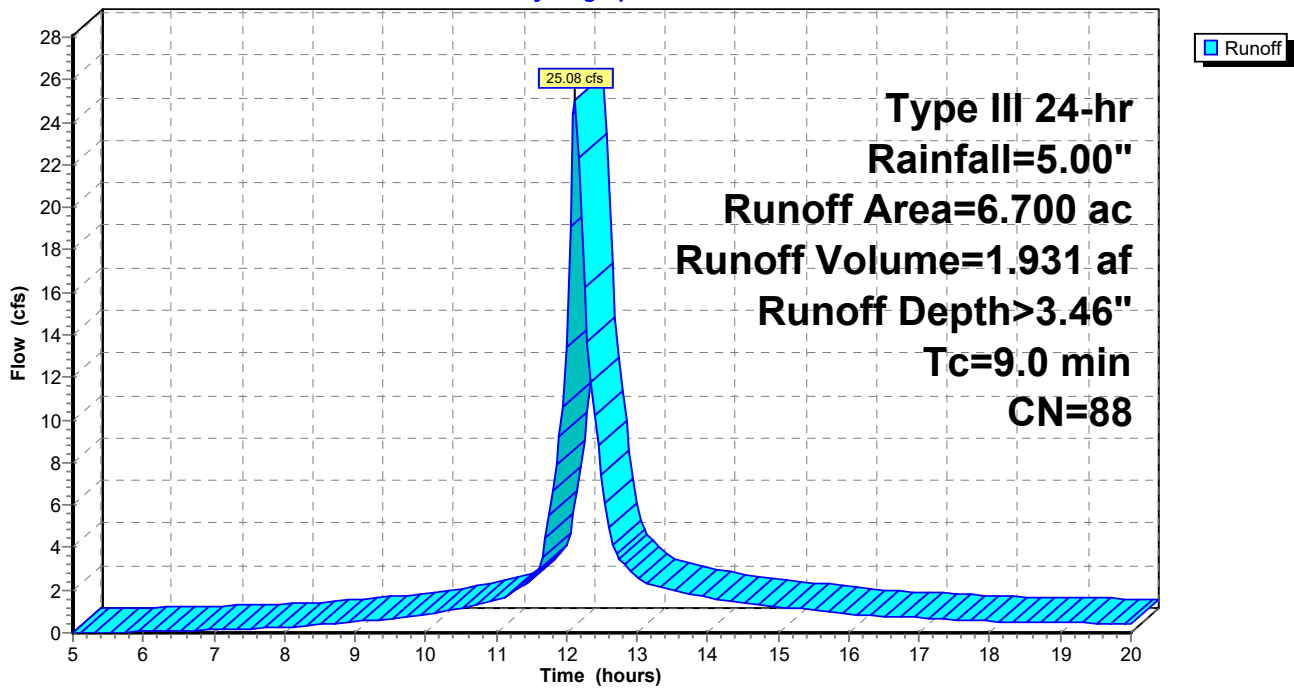

EXISTING FLOW PATTERN

Prepared by HP Inc.

HydroCAD® 10.00-26 s/n 10718 © 2020 HydroCAD Software Solutions LLC

Type III 24-hr Rainfall=5.00"

Printed 4/6/2023

Page 15

Summary for Subcatchment 10S: Bridge St. Area

Runoff = 20.01 cfs @ 12.09 hrs, Volume= 1.449 af, Depth> 3.86"

Runoff by SCS TR-20 method, UH=SCS, Weighted-CN, Time Span= 5.00-20.00 hrs, dt= 0.05 hrs
Type III 24-hr Rainfall=5.00"

Area (ac)	CN	Description
* 4.500	92	

Tc (min)	Length (feet)	Slope (ft/ft)	Velocity (ft/sec)	Capacity (cfs)	Description
6.0					Direct Entry,

Subcatchment 10S: Bridge St. Area

Hydrograph

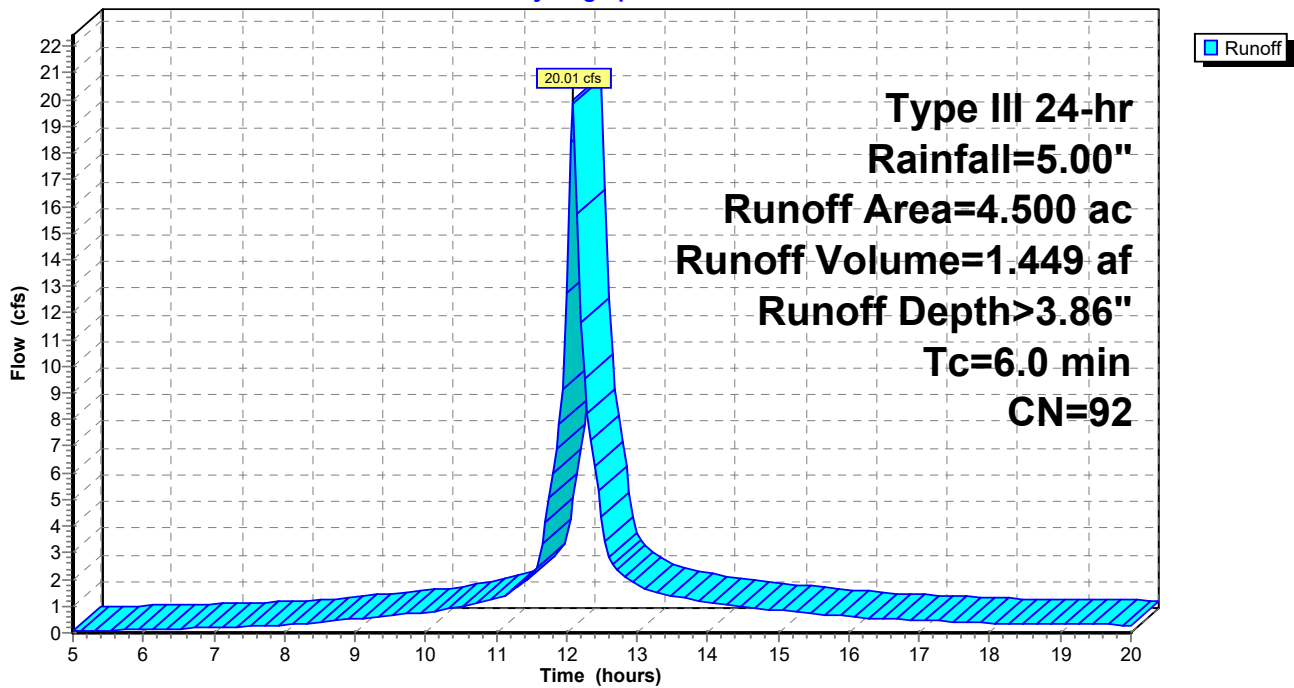

EXISTING FLOW PATTERN

Prepared by HP Inc.

HydroCAD® 10.00-26 s/n 10718 © 2020 HydroCAD Software Solutions LLC

Type III 24-hr Rainfall=5.00"

Printed 4/6/2023

Page 16

Summary for Subcatchment 11S: Parking Garage/Lot

Runoff = 9.17 cfs @ 12.09 hrs, Volume= 0.677 af, Depth> 4.06"

Runoff by SCS TR-20 method, UH=SCS, Weighted-CN, Time Span= 5.00-20.00 hrs, dt= 0.05 hrs
Type III 24-hr Rainfall=5.00"

Area (ac)	CN	Description
* 2.000	94	

Tc (min)	Length (feet)	Slope (ft/ft)	Velocity (ft/sec)	Capacity (cfs)	Description
6.0					Direct Entry,

Subcatchment 11S: Parking Garage/Lot

Hydrograph

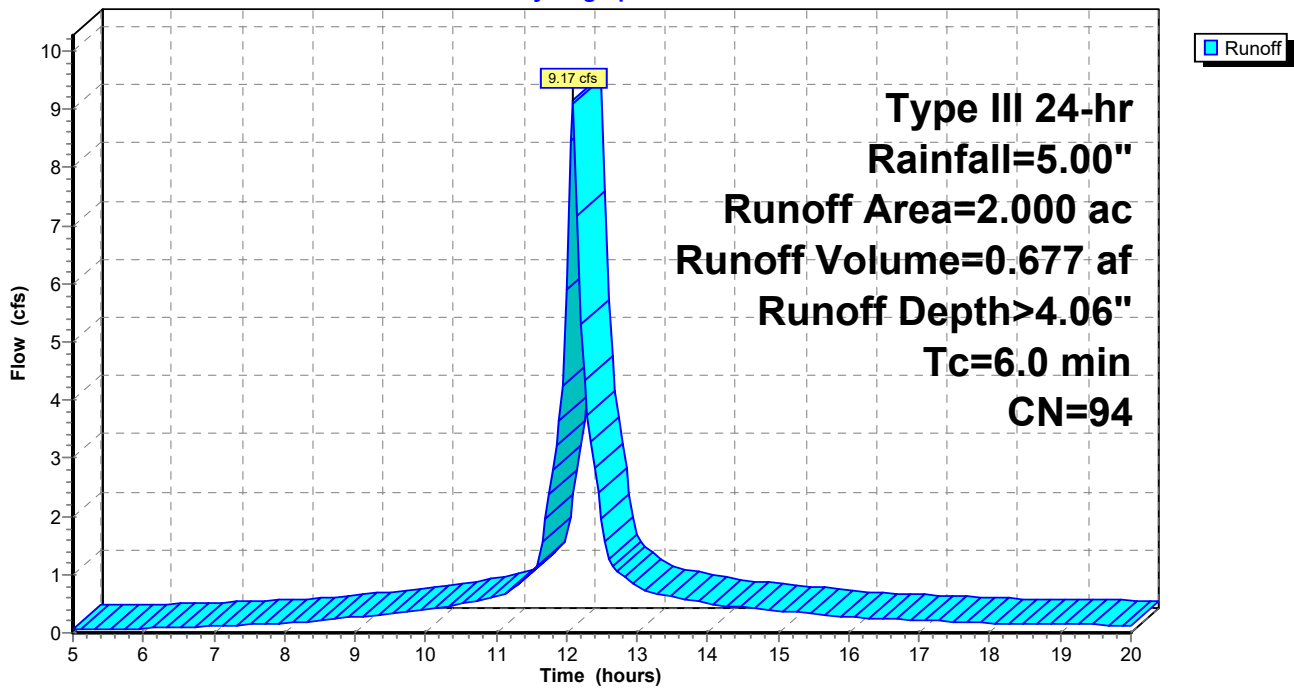

EXISTING FLOW PATTERN

Prepared by HP Inc.

HydroCAD® 10.00-26 s/n 10718 © 2020 HydroCAD Software Solutions LLC

Type III 24-hr Rainfall=5.00"

Printed 4/6/2023

Page 17

Summary for Subcatchment 12S: Maplewood/Deer Street area

Runoff = 14.80 cfs @ 12.14 hrs, Volume= 1.150 af, Depth> 3.07"

Runoff by SCS TR-20 method, UH=SCS, Weighted-CN, Time Span= 5.00-20.00 hrs, dt= 0.05 hrs
Type III 24-hr Rainfall=5.00"

Area (ac)	CN	Description
* 4.500	84	

Tc (min)	Length (feet)	Slope (ft/ft)	Velocity (ft/sec)	Capacity (cfs)	Description
10.0					Direct Entry,

Subcatchment 12S: Maplewood/Deer Street area

Hydrograph

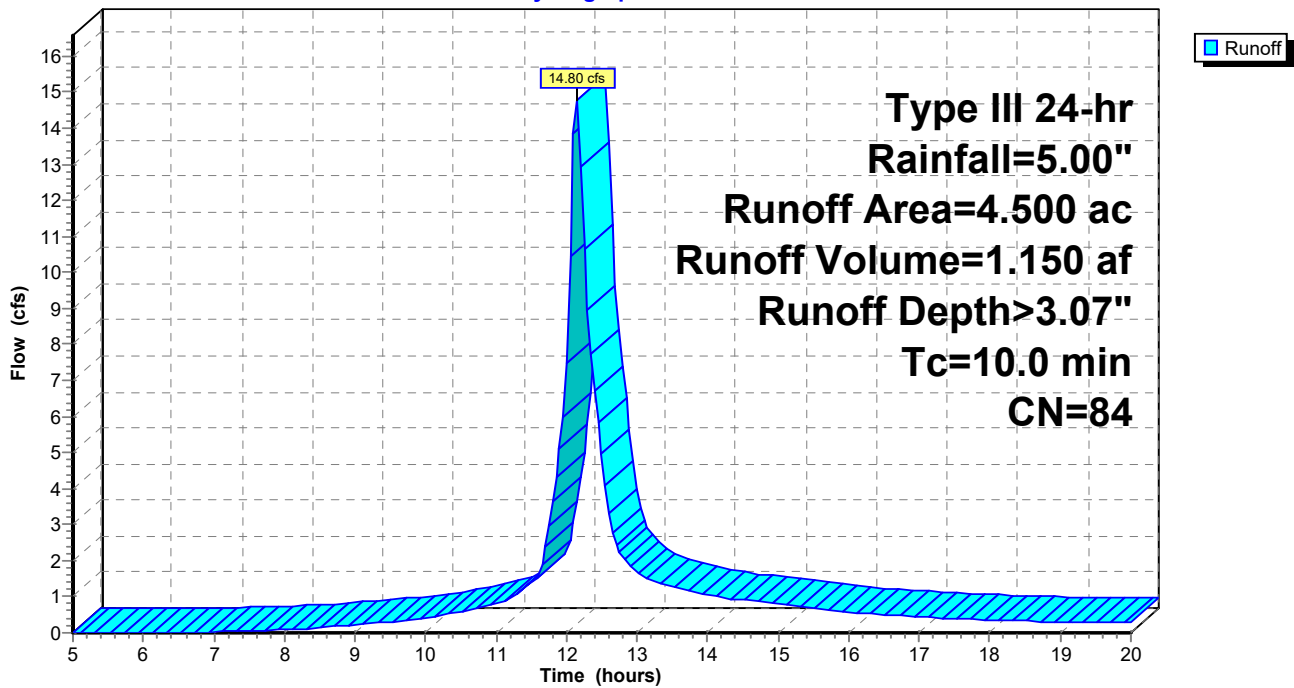

EXISTING FLOW PATTERN

Prepared by HP Inc.

HydroCAD® 10.00-26 s/n 10718 © 2020 HydroCAD Software Solutions LLC

Type III 24-hr Rainfall=5.00"

Printed 4/6/2023

Page 18

Summary for Reach 1R: Fleet St. (from Porter to Congress)

Inflow Area = 2.500 ac, Inflow Depth > 4.06"
Inflow = 11.47 cfs @ 12.09 hrs, Volume= 0.847 af
Outflow = 11.30 cfs @ 12.10 hrs, Volume= 0.846 af, Atten= 1%, Lag= 0.7 min

Routing by Stor-Ind+Trans method, Time Span= 5.00-20.00 hrs, dt= 0.05 hrs
Max. Velocity= 7.86 fps, Min. Travel Time= 0.4 min
Avg. Velocity = 3.19 fps, Avg. Travel Time= 0.9 min

Peak Storage= 263 cf @ 12.09 hrs
Average Depth at Peak Storage= 1.16'
Bank-Full Depth= 1.50' Flow Area= 1.8 sf, Capacity= 12.21 cfs

18.0" Round Pipe
n= 0.010
Length= 180.0' Slope= 0.0080 '/'
Inlet Invert= 0.00', Outlet Invert= -1.44'

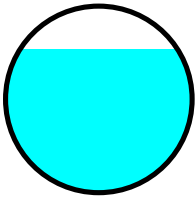

Reach 1R: Fleet St. (from Porter to Congress)

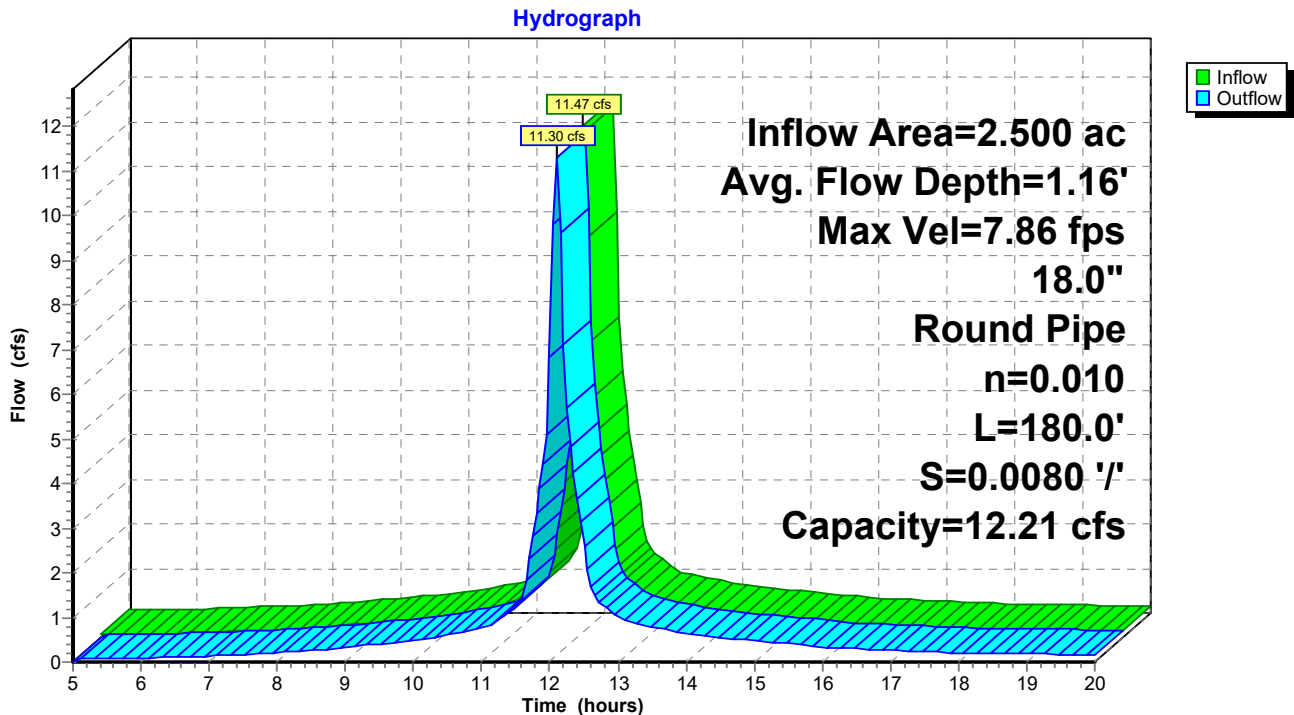

EXISTING FLOW PATTERN

Prepared by HP Inc.

HydroCAD® 10.00-26 s/n 10718 © 2020 HydroCAD Software Solutions LLC

Type III 24-hr Rainfall=5.00"

Printed 4/6/2023

Page 19

Summary for Reach 2R: Fleet St. (West of Congress)

Inflow Area = 3.600 ac, Inflow Depth > 4.12"
Inflow = 16.44 cfs @ 12.09 hrs, Volume= 1.236 af
Outflow = 15.95 cfs @ 12.11 hrs, Volume= 1.235 af, Atten= 3%, Lag= 1.0 min

Routing by Stor-Ind+Trans method, Time Span= 5.00-20.00 hrs, dt= 0.05 hrs
Max. Velocity= 5.84 fps, Min. Travel Time= 0.6 min
Avg. Velocity = 2.45 fps, Avg. Travel Time= 1.4 min

Peak Storage= 559 cf @ 12.10 hrs
Average Depth at Peak Storage= 1.67'
Bank-Full Depth= 2.00' Flow Area= 3.1 sf, Capacity= 16.11 cfs

24.0" Round Pipe
n= 0.010
Length= 200.0' Slope= 0.0030 '/'
Inlet Invert= 0.00', Outlet Invert= -0.60'

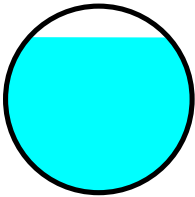

Reach 2R: Fleet St. (West of Congress)

Hydrograph

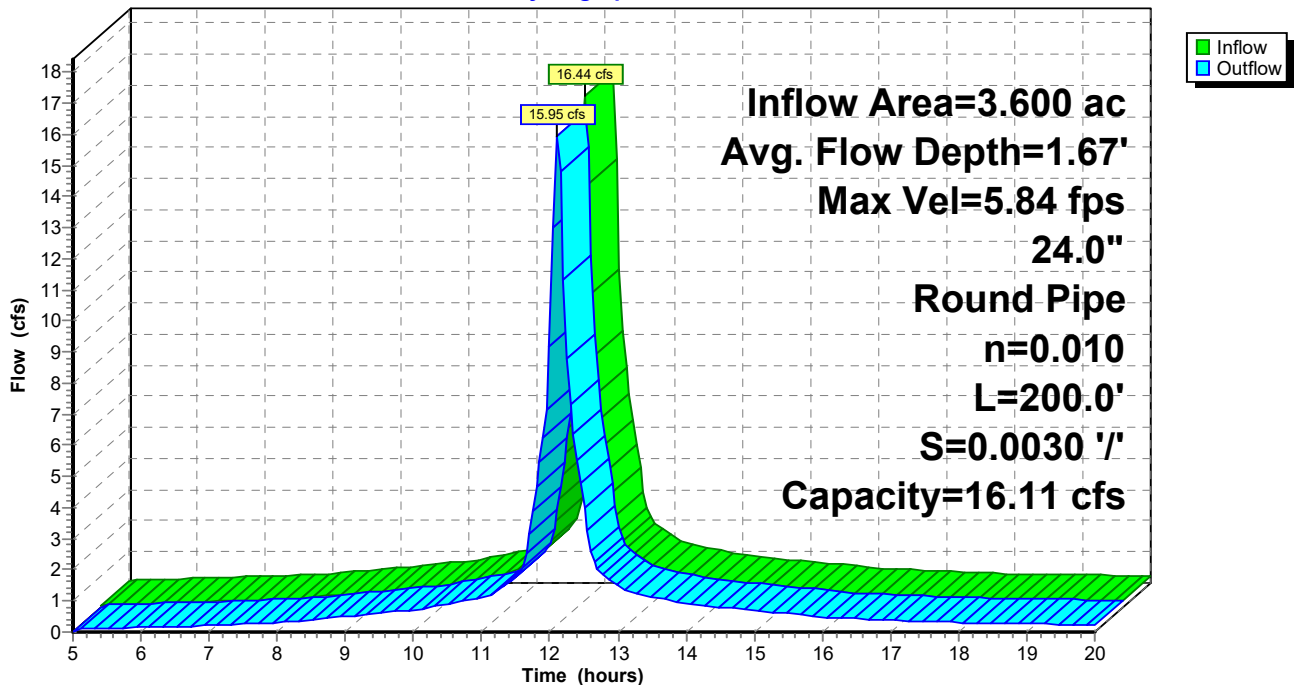

EXISTING FLOW PATTERN

Prepared by HP Inc.

HydroCAD® 10.00-26 s/n 10718 © 2020 HydroCAD Software Solutions LLC

Type III 24-hr Rainfall=5.00"

Printed 4/6/2023

Page 20

Summary for Reach 3R: To Hanover St.

Inflow Area = 1.300 ac, Inflow Depth > 4.25"
Inflow = 6.11 cfs @ 12.09 hrs, Volume= 0.461 af
Outflow = 6.05 cfs @ 12.09 hrs, Volume= 0.461 af, Atten= 1%, Lag= 0.4 min

Routing by Stor-Ind+Trans method, Time Span= 5.00-20.00 hrs, dt= 0.05 hrs
Max. Velocity= 5.51 fps, Min. Travel Time= 0.2 min
Avg. Velocity = 2.33 fps, Avg. Travel Time= 0.6 min

Peak Storage= 89 cf @ 12.09 hrs
Average Depth at Peak Storage= 1.06'
Bank-Full Depth= 1.25' Flow Area= 1.2 sf, Capacity= 5.94 cfs

15.0" Round Pipe
n= 0.010
Length= 80.0' Slope= 0.0050 '/'
Inlet Invert= 0.00', Outlet Invert= -0.40'

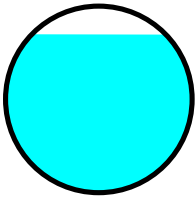

Reach 3R: To Hanover St.

Hydrograph

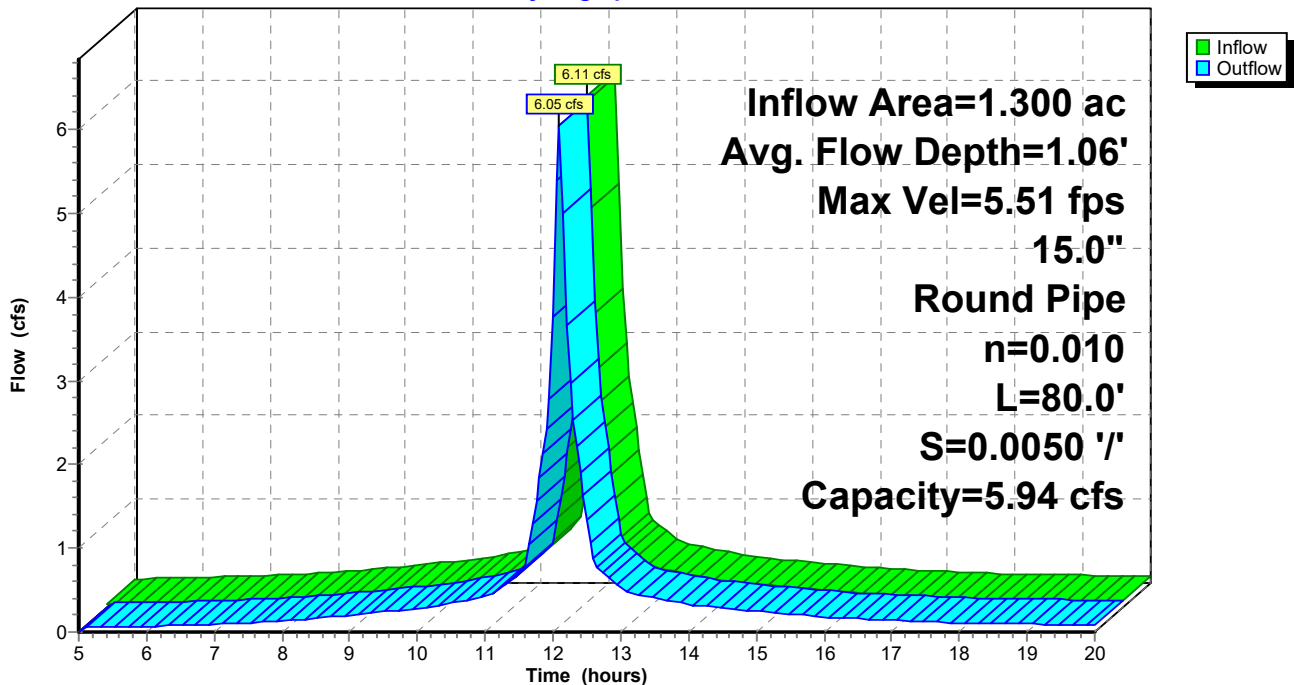

EXISTING FLOW PATTERN

Prepared by HP Inc.

HydroCAD® 10.00-26 s/n 10718 © 2020 HydroCAD Software Solutions LLC

Type III 24-hr Rainfall=5.00"

Printed 4/6/2023

Page 21

Summary for Reach 4R: Hanover - Downstream from Fleet

Inflow Area = 8.100 ac, Inflow Depth > 4.06"
Inflow = 35.74 cfs @ 12.10 hrs, Volume= 2.738 af
Outflow = 35.13 cfs @ 12.11 hrs, Volume= 2.736 af, Atten= 2%, Lag= 0.6 min

Routing by Stor-Ind+Trans method, Time Span= 5.00-20.00 hrs, dt= 0.05 hrs
Max. Velocity= 8.62 fps, Min. Travel Time= 0.3 min
Avg. Velocity = 3.57 fps, Avg. Travel Time= 0.8 min

Peak Storage= 744 cf @ 12.10 hrs
Average Depth at Peak Storage= 1.96'
Bank-Full Depth= 2.50' Flow Area= 4.9 sf, Capacity= 37.18 cfs

30.0" Round Pipe
n= 0.012
Length= 180.0' Slope= 0.0070 '/'
Inlet Invert= 0.00', Outlet Invert= -1.26'

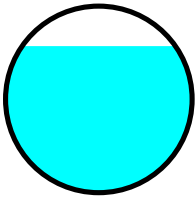

Reach 4R: Hanover - Downstream from Fleet

Hydrograph

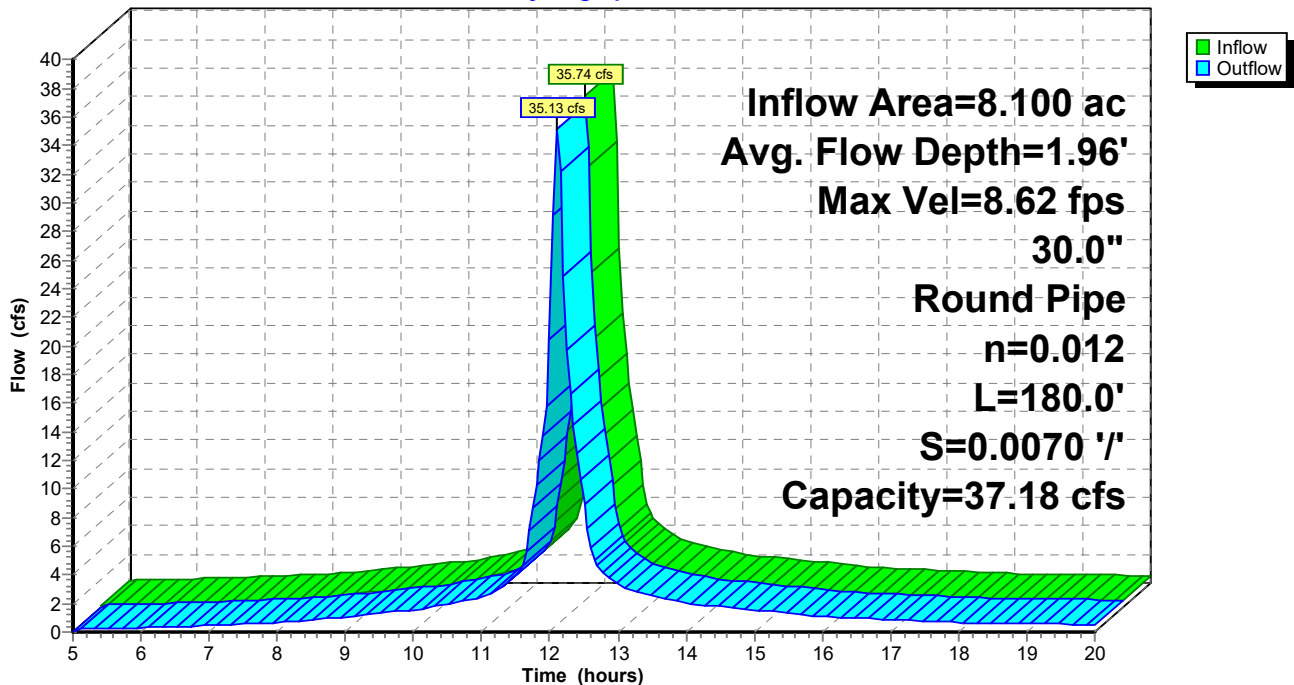

EXISTING FLOW PATTERN

Prepared by HP Inc.

HydroCAD® 10.00-26 s/n 10718 © 2020 HydroCAD Software Solutions LLC

Type III 24-hr Rainfall=5.00"

Printed 4/6/2023

Page 22

Summary for Reach 5R: Congress to Vaughn Mall

Inflow Area = 5.700 ac, Inflow Depth > 4.10"
Inflow = 25.40 cfs @ 12.10 hrs, Volume= 1.946 af
Outflow = 25.21 cfs @ 12.11 hrs, Volume= 1.946 af, Atten= 1%, Lag= 0.3 min

Routing by Stor-Ind+Trans method, Time Span= 5.00-20.00 hrs, dt= 0.05 hrs
Max. Velocity= 10.08 fps, Min. Travel Time= 0.2 min
Avg. Velocity = 4.12 fps, Avg. Travel Time= 0.4 min

Peak Storage= 252 cf @ 12.10 hrs
Average Depth at Peak Storage= 1.50'
Bank-Full Depth= 2.00' Flow Area= 3.1 sf, Capacity= 27.94 cfs

24.0" Round Pipe
n= 0.012
Length= 100.0' Slope= 0.0130 '/'
Inlet Invert= 0.00', Outlet Invert= -1.30'

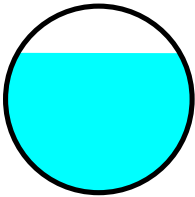

Reach 5R: Congress to Vaughn Mall

Hydrograph

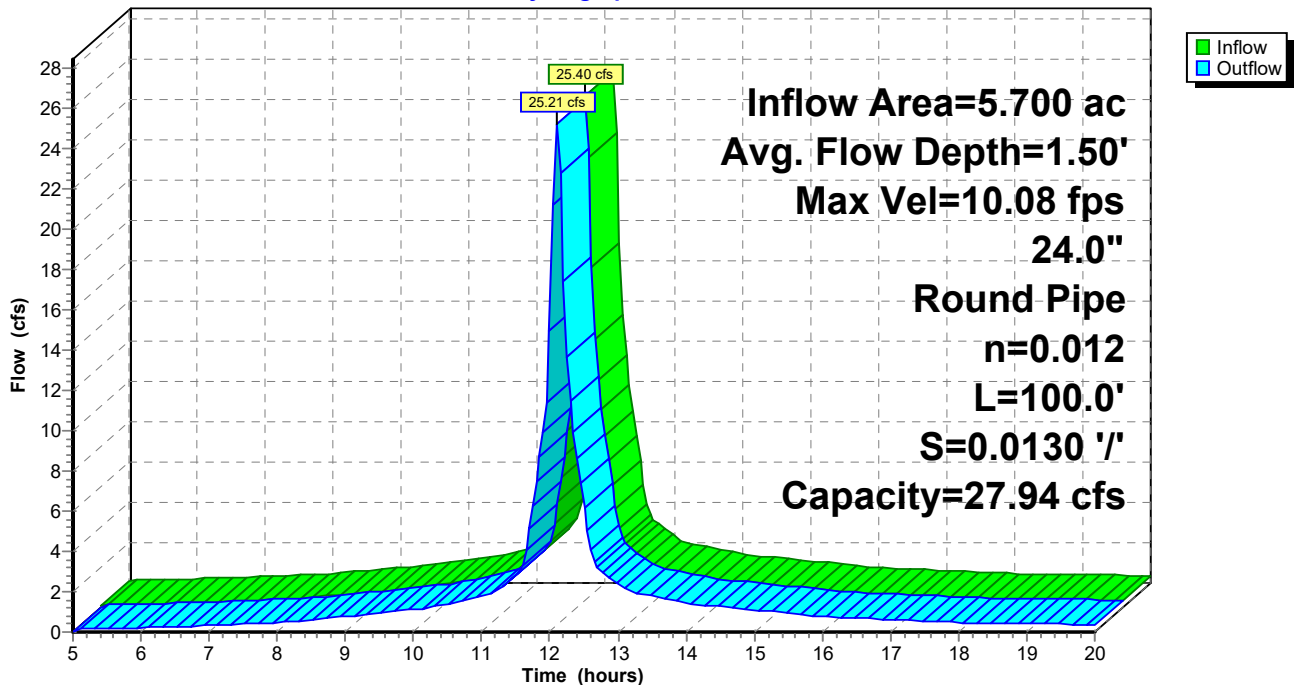

EXISTING FLOW PATTERN

Prepared by HP Inc.

HydroCAD® 10.00-26 s/n 10718 © 2020 HydroCAD Software Solutions LLC

Type III 24-hr Rainfall=5.00"

Printed 4/6/2023

Page 23

Summary for Reach 6R: Upper Vaughn Mall

Inflow Area = 6.800 ac, Inflow Depth > 4.09"
Inflow = 30.18 cfs @ 12.10 hrs, Volume= 2.318 af
Outflow = 29.74 cfs @ 12.11 hrs, Volume= 2.318 af, Atten= 1%, Lag= 0.5 min

Routing by Stor-Ind+Trans method, Time Span= 5.00-20.00 hrs, dt= 0.05 hrs
Max. Velocity= 11.19 fps, Min. Travel Time= 0.3 min
Avg. Velocity = 4.65 fps, Avg. Travel Time= 0.7 min

Peak Storage= 538 cf @ 12.11 hrs
Average Depth at Peak Storage= 1.60'
Bank-Full Depth= 2.00' Flow Area= 3.1 sf, Capacity= 30.84 cfs

24.0" Round Pipe
n= 0.010
Length= 200.0' Slope= 0.0110 '/'
Inlet Invert= 0.00', Outlet Invert= -2.20'

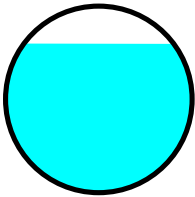

Reach 6R: Upper Vaughn Mall

Hydrograph

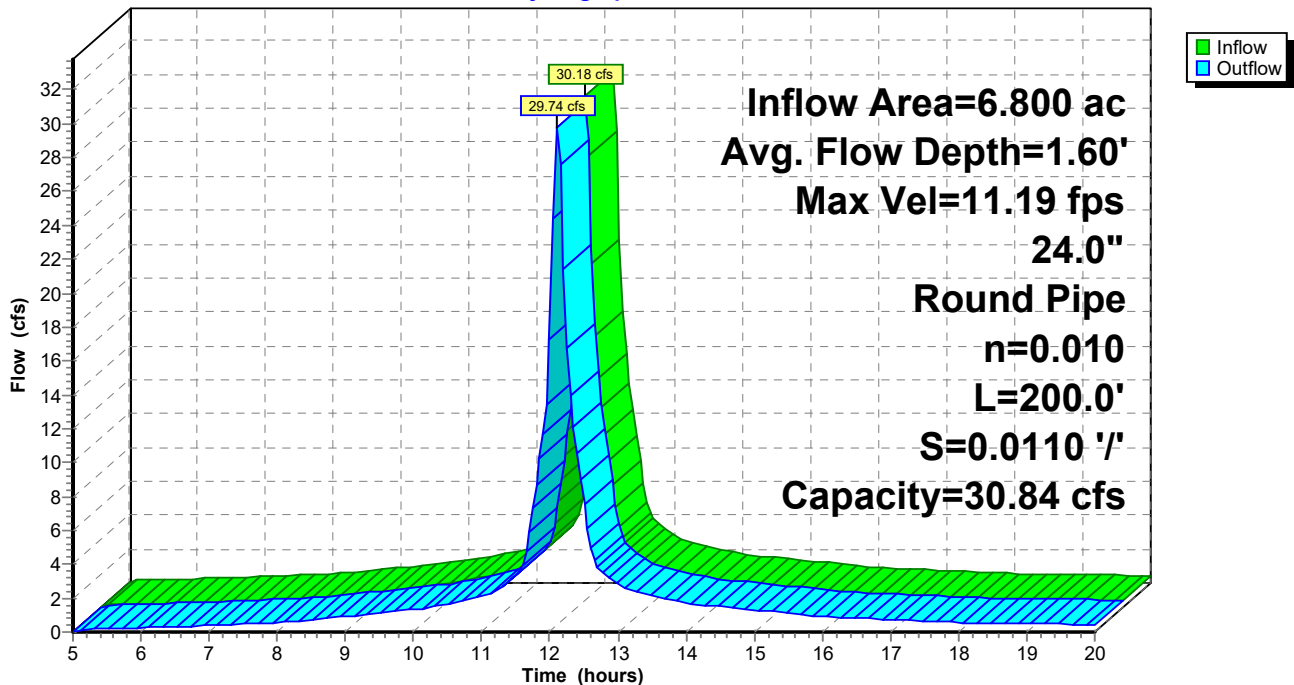

EXISTING FLOW PATTERN

Prepared by HP Inc.

HydroCAD® 10.00-26 s/n 10718 © 2020 HydroCAD Software Solutions LLC

Type III 24-hr Rainfall=5.00"

Printed 4/6/2023

Page 24

Summary for Reach 7R: Lower Vaughn Mall to Hanover

Inflow Area = 8.200 ac, Inflow Depth > 4.09"
Inflow = 35.99 cfs @ 12.11 hrs, Volume= 2.792 af
Outflow = 35.62 cfs @ 12.11 hrs, Volume= 2.791 af, Atten= 1%, Lag= 0.4 min

Routing by Stor-Ind+Trans method, Time Span= 5.00-20.00 hrs, dt= 0.05 hrs
Max. Velocity= 12.61 fps, Min. Travel Time= 0.2 min
Avg. Velocity = 5.35 fps, Avg. Travel Time= 0.5 min

Peak Storage= 427 cf @ 12.11 hrs
Average Depth at Peak Storage= 1.70'
Bank-Full Depth= 2.00' Flow Area= 3.1 sf, Capacity= 34.80 cfs

24.0" Round Pipe
n= 0.010
Length= 150.0' Slope= 0.0140 '/'
Inlet Invert= 0.00', Outlet Invert= -2.10'

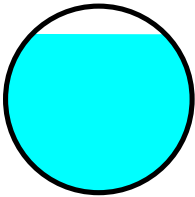

Reach 7R: Lower Vaughn Mall to Hanover

Hydrograph

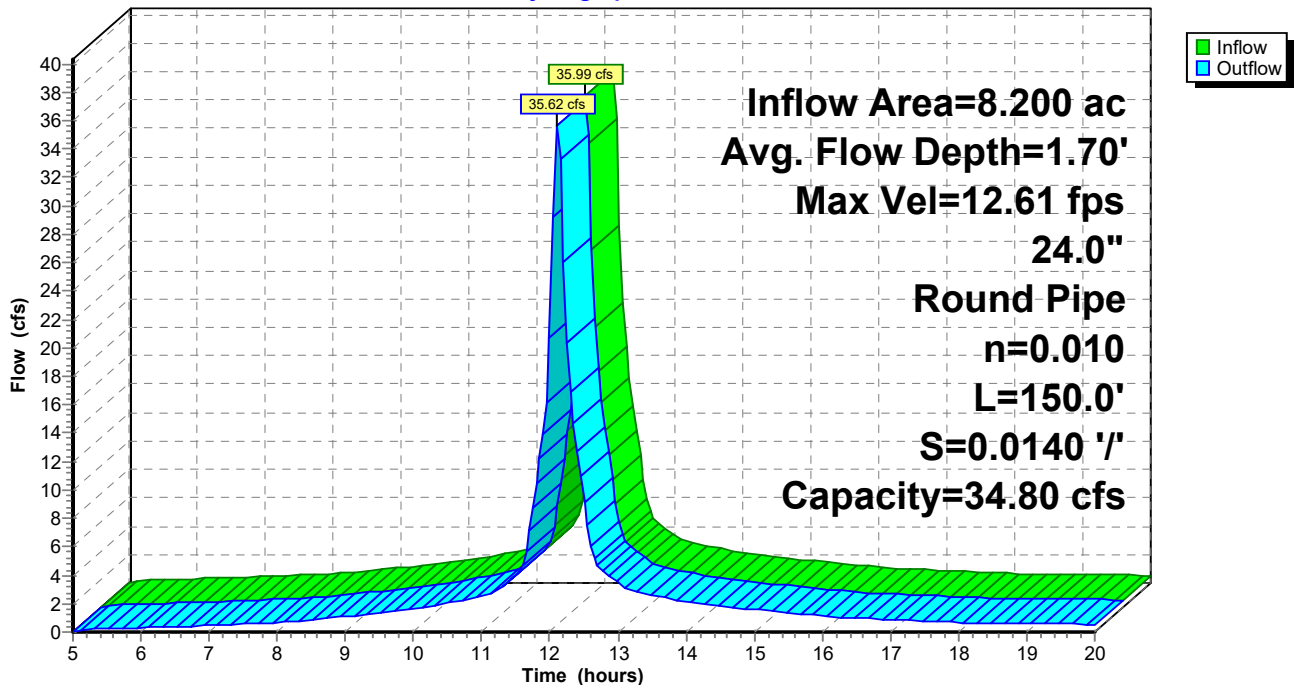

EXISTING FLOW PATTERN

Prepared by HP Inc.

HydroCAD® 10.00-26 s/n 10718 © 2020 HydroCAD Software Solutions LLC

Type III 24-hr Rainfall=5.00"

Printed 4/6/2023

Page 25

Summary for Reach 8R: Exist. 36" RCP, Downstream of V. Mall

Inflow Area = 17.500 ac, Inflow Depth > 4.06"
 Inflow = 75.93 cfs @ 12.11 hrs, Volume= 5.914 af
 Outflow = 74.85 cfs @ 12.12 hrs, Volume= 5.912 af, Atten= 1%, Lag= 0.5 min

Routing by Stor-Ind+Trans method, Time Span= 5.00-20.00 hrs, dt= 0.05 hrs
 Max. Velocity= 12.22 fps, Min. Travel Time= 0.3 min
 Avg. Velocity = 5.13 fps, Avg. Travel Time= 0.6 min

Peak Storage= 1,237 cf @ 12.11 hrs
 Average Depth at Peak Storage= 2.45'
 Bank-Full Depth= 3.00' Flow Area= 7.1 sf, Capacity= 75.78 cfs

36.0" Round Pipe
 n= 0.012
 Length= 200.0' Slope= 0.0110 '/'
 Inlet Invert= 0.00', Outlet Invert= -2.20'

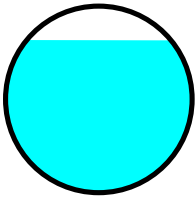

Reach 8R: Exist. 36" RCP, Downstream of V. Mall

Hydrograph

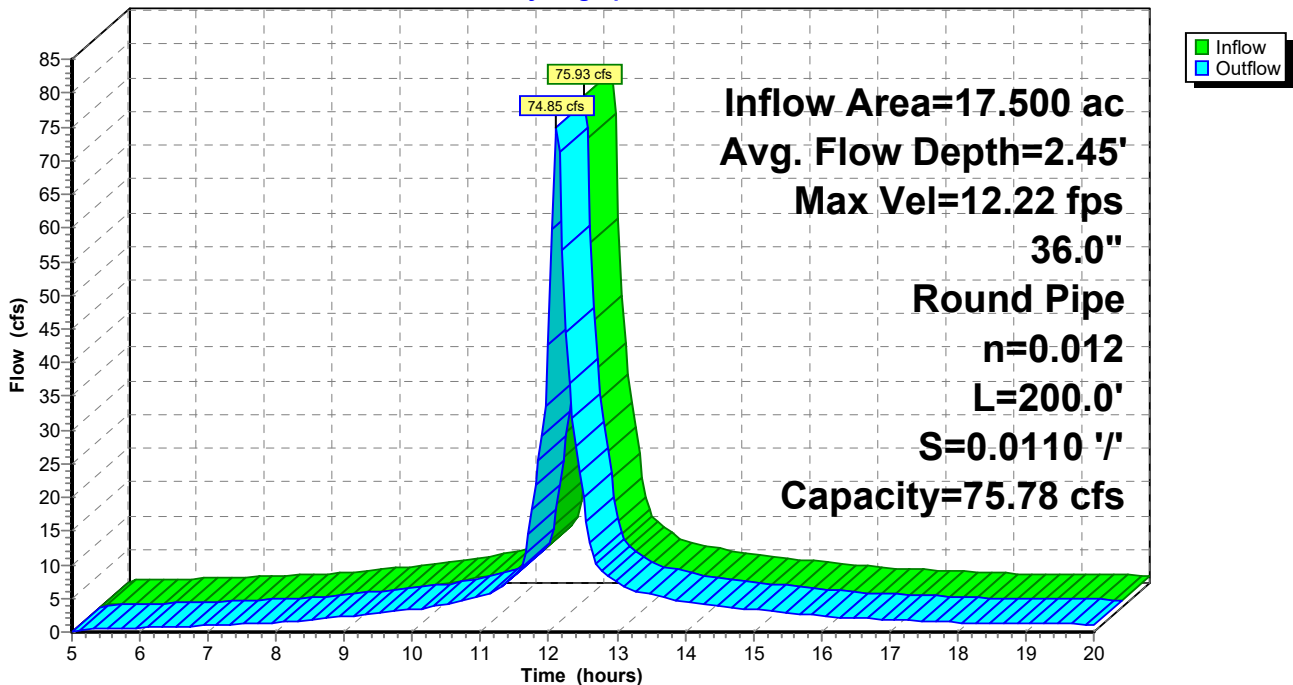

EXISTING FLOW PATTERN

Prepared by HP Inc.

HydroCAD® 10.00-26 s/n 10718 © 2020 HydroCAD Software Solutions LLC

Type III 24-hr Rainfall=5.00"

Printed 4/6/2023

Page 26

Summary for Reach 9R: Existr 36" from Han. Sag

Inflow Area = 19.300 ac, Inflow Depth > 4.07"
Inflow = 82.94 cfs @ 12.11 hrs, Volume= 6.550 af
Outflow = 81.35 cfs @ 12.13 hrs, Volume= 6.548 af, Atten= 2%, Lag= 0.7 min

Routing by Stor-Ind+Trans method, Time Span= 5.00-20.00 hrs, dt= 0.05 hrs
Max. Velocity= 12.76 fps, Min. Travel Time= 0.3 min
Avg. Velocity = 5.45 fps, Avg. Travel Time= 0.8 min

Peak Storage= 1,681 cf @ 12.12 hrs
Average Depth at Peak Storage= 2.57'
Bank-Full Depth= 3.00' Flow Area= 7.1 sf, Capacity= 79.15 cfs

36.0" Round Pipe
n= 0.012
Length= 260.0' Slope= 0.0120 '/'
Inlet Invert= 0.00', Outlet Invert= -3.12'

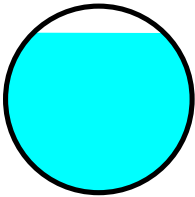

Reach 9R: Existr 36" from Han. Sag

Hydrograph

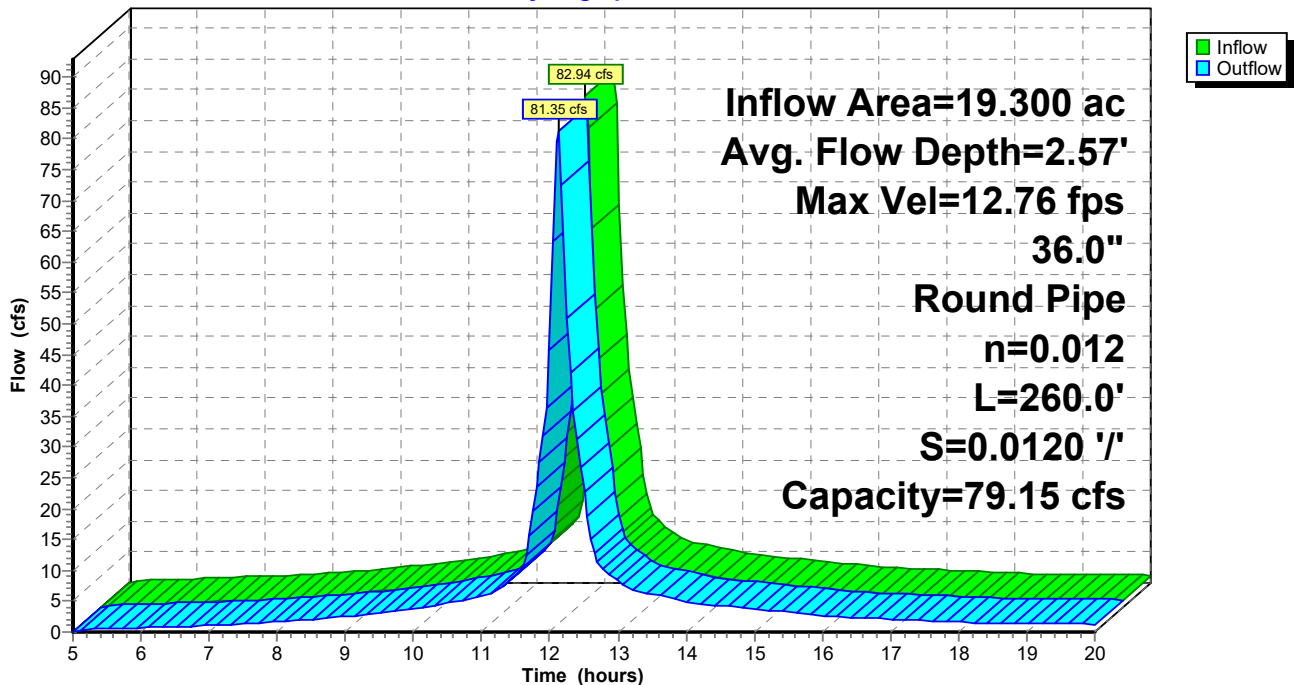

EXISTING FLOW PATTERN

Prepared by HP Inc.

HydroCAD® 10.00-26 s/n 10718 © 2020 HydroCAD Software Solutions LLC

Type III 24-hr Rainfall=5.00"

Printed 4/6/2023

Page 27

Summary for Reach 10R: Upper Bridge St.

Inflow Area = 26.000 ac, Inflow Depth > 3.91"
Inflow = 106.28 cfs @ 12.13 hrs, Volume= 8.478 af
Outflow = 105.46 cfs @ 12.14 hrs, Volume= 8.475 af, Atten= 1%, Lag= 0.7 min

Routing by Stor-Ind+Trans method, Time Span= 5.00-20.00 hrs, dt= 0.05 hrs
Max. Velocity= 9.50 fps, Min. Travel Time= 0.3 min
Avg. Velocity = 4.01 fps, Avg. Travel Time= 0.7 min

Peak Storage= 1,900 cf @ 12.13 hrs
Average Depth at Peak Storage= 3.32'
Bank-Full Depth= 4.00' Flow Area= 12.6 sf, Capacity= 104.73 cfs

48.0" Round Pipe
n= 0.012
Length= 170.0' Slope= 0.0045 '/'
Inlet Invert= 0.00', Outlet Invert= -0.77'

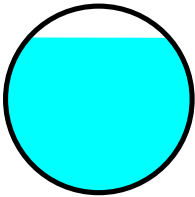

Reach 10R: Upper Bridge St.

Hydrograph

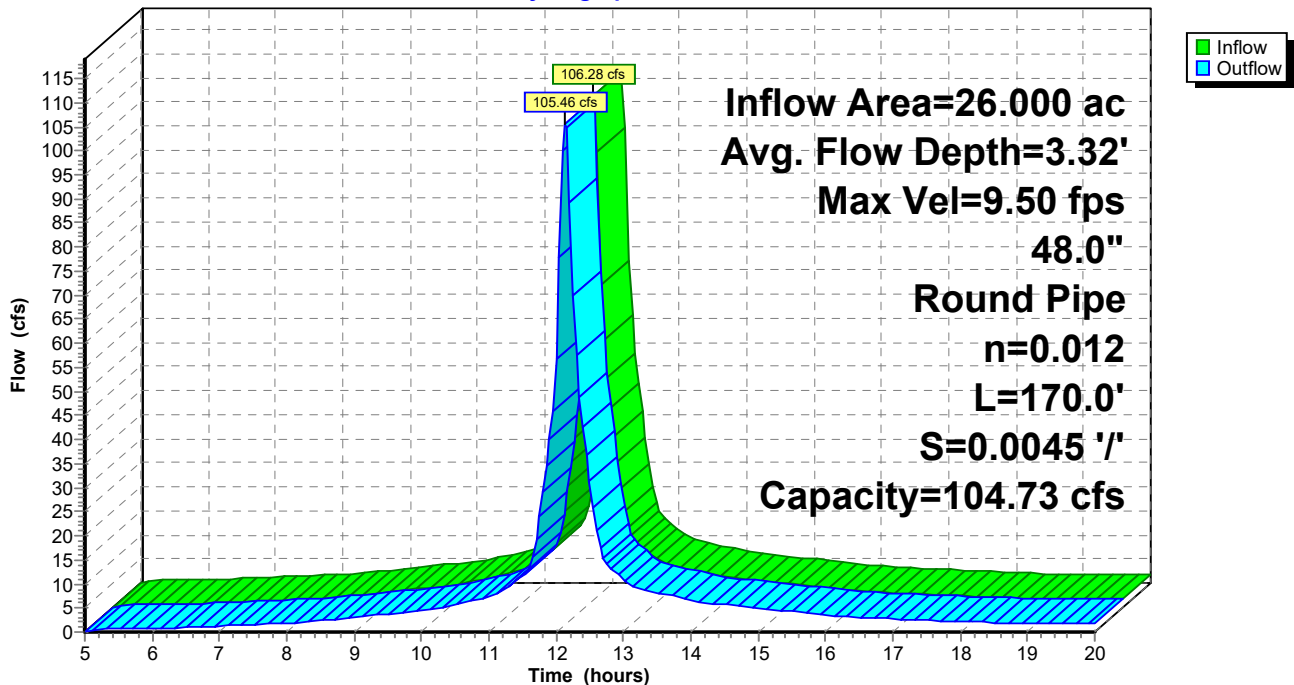

EXISTING FLOW PATTERN

Prepared by HP Inc.

HydroCAD® 10.00-26 s/n 10718 © 2020 HydroCAD Software Solutions LLC

Type III 24-hr Rainfall=5.00"

Printed 4/6/2023

Page 28

Summary for Reach 11R: Bridge Street Sag

Inflow Area = 30.500 ac, Inflow Depth > 3.90"
Inflow = 122.72 cfs @ 12.13 hrs, Volume= 9.925 af
Outflow = 122.01 cfs @ 12.14 hrs, Volume= 9.922 af, Atten= 1%, Lag= 0.6 min

Routing by Stor-Ind+Trans method, Time Span= 5.00-20.00 hrs, dt= 0.05 hrs
Max. Velocity= 10.93 fps, Min. Travel Time= 0.2 min
Avg. Velocity = 4.63 fps, Avg. Travel Time= 0.6 min

Peak Storage= 1,795 cf @ 12.13 hrs
Average Depth at Peak Storage= 3.34'
Bank-Full Depth= 4.00' Flow Area= 12.6 sf, Capacity= 120.54 cfs

48.0" Round Pipe
n= 0.012
Length= 160.0' Slope= 0.0060 '/'
Inlet Invert= 0.00', Outlet Invert= -0.96'

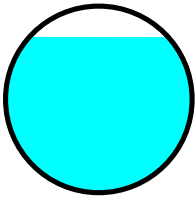

Reach 11R: Bridge Street Sag

Hydrograph

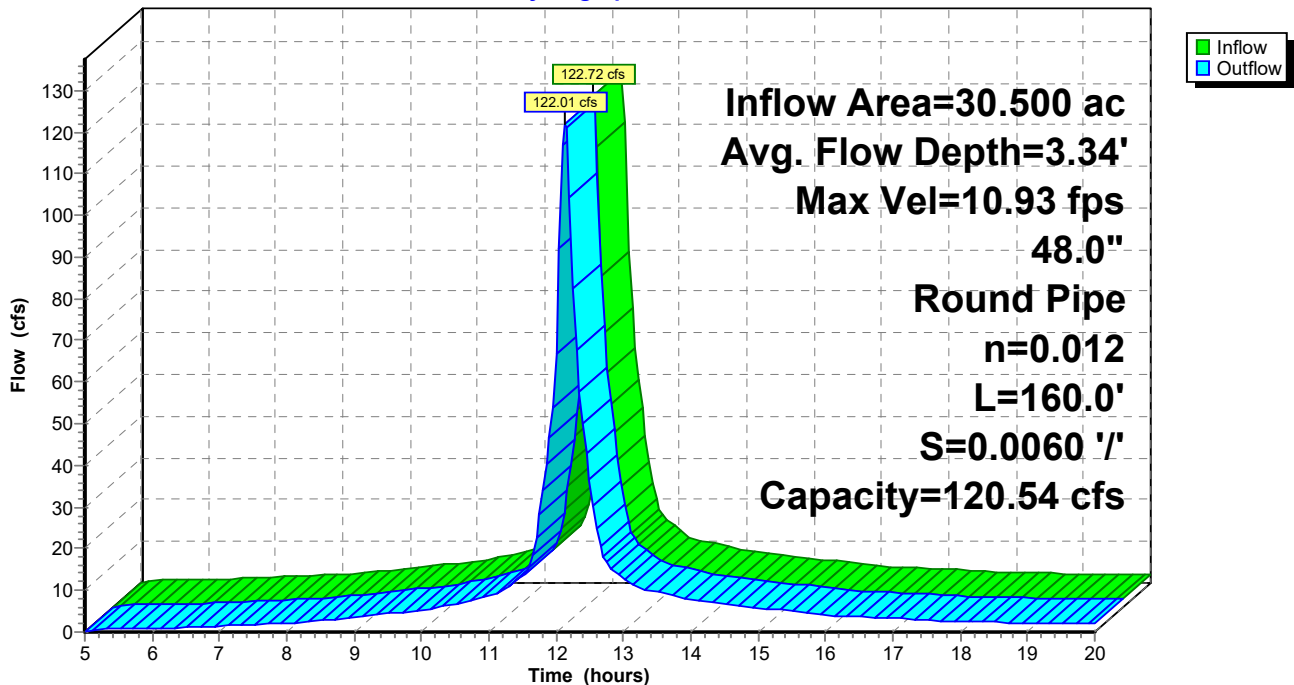

EXISTING FLOW PATTERN

Prepared by HP Inc.

HydroCAD® 10.00-26 s/n 10718 © 2020 HydroCAD Software Solutions LLC

Type III 24-hr Rainfall=5.00"

Printed 4/6/2023

Page 29

Summary for Reach 12R: Deer Street

Inflow Area = 32.500 ac, Inflow Depth > 3.91"
Inflow = 129.83 cfs @ 12.13 hrs, Volume= 10.599 af
Outflow = 129.15 cfs @ 12.14 hrs, Volume= 10.596 af, Atten= 1%, Lag= 0.5 min

Routing by Stor-Ind+Trans method, Time Span= 5.00-20.00 hrs, dt= 0.05 hrs
Max. Velocity= 11.81 fps, Min. Travel Time= 0.2 min
Avg. Velocity = 4.98 fps, Avg. Travel Time= 0.5 min

Peak Storage= 1,758 cf @ 12.14 hrs
Average Depth at Peak Storage= 3.26'
Bank-Full Depth= 4.00' Flow Area= 12.6 sf, Capacity= 130.20 cfs

48.0" Round Pipe
n= 0.012
Length= 160.0' Slope= 0.0070 '/'
Inlet Invert= 0.00', Outlet Invert= -1.12'

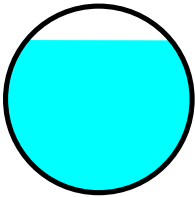

Reach 12R: Deer Street

Hydrograph

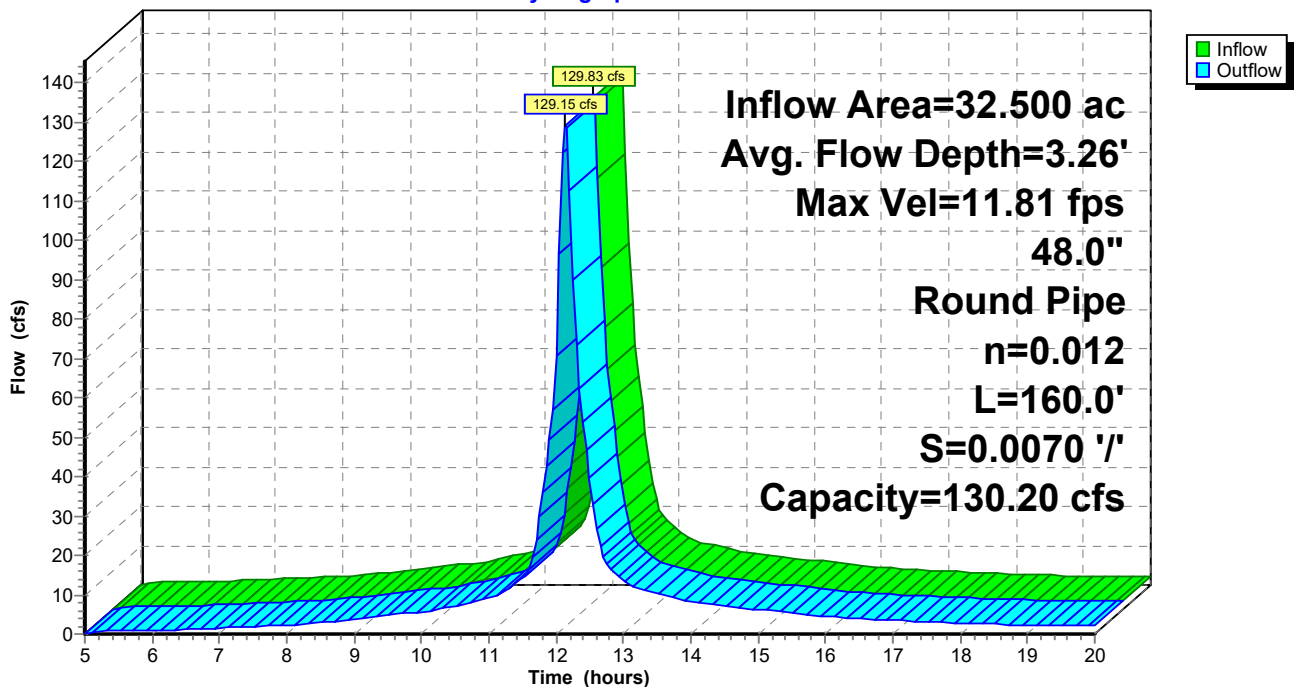

EXISTING FLOW PATTERN

Prepared by HP Inc.

HydroCAD® 10.00-26 s/n 10718 © 2020 HydroCAD Software Solutions LLC

Type III 24-hr Rainfall=5.00"

Printed 4/6/2023

Page 30

Summary for Pond 13P: Deer Stret Outfall Pipe(s)

Inflow Area = 37.000 ac, Inflow Depth > 3.81"
 Inflow = 143.94 cfs @ 12.14 hrs, Volume= 11.746 af
 Outflow = 143.94 cfs @ 12.14 hrs, Volume= 11.746 af, Atten= 0%, Lag= 0.0 min
 Primary = 143.94 cfs @ 12.14 hrs, Volume= 11.746 af

Routing by Stor-Ind method, Time Span= 5.00-20.00 hrs, dt= 0.05 hrs
 Peak Elev= 6.00' @ 12.14 hrs

Device	Routing	Invert	Outlet Devices
#1	Primary	0.00'	48.0" Round Twin Culverts X 2.00 L= 575.0' RCP, sq.cut end projecting, Ke= 0.500 Inlet / Outlet Invert= 0.00' / -1.15' S= 0.0020 '/ Cc= 0.900 n= 0.012, Flow Area= 12.57 sf

Primary OutFlow Max=141.87 cfs @ 12.14 hrs HW=5.94' TW=4.00' (Fixed TW Elev= 4.00')
 ↳1=Twin Culverts (Outlet Controls 141.87 cfs @ 5.64 fps)

Pond 13P: Deer Stret Outfall Pipe(s)

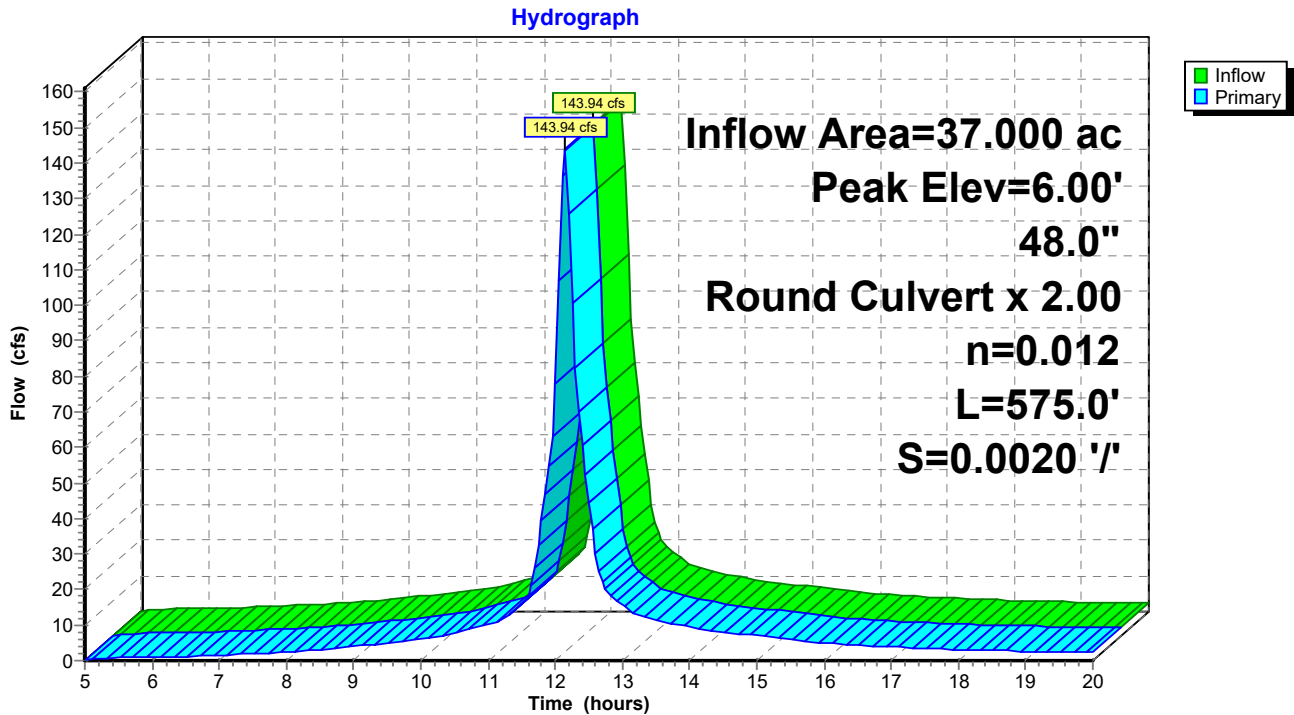

APPENDIX 4
DRAINAGE OUTFALL PROJECT
POST-PROJECT HYDROLOGY CALCULATIONS

Deer Street Outfall & Fleet Street Drainage Areas Portsmouth, New Hampshire November 2020

Project Conditions
October 2022

SCALE: 1"=100'
SCALE: 1 INCH = 100 FT.

Lighter colors, similar to the "existing conditions October 2022" created for Phil

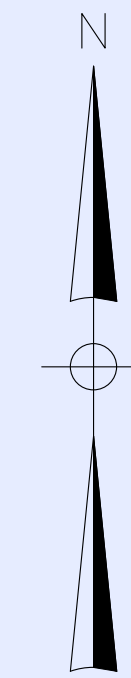

Post Construction Basin 12A in to Maplewood Pipe

Post Construction Basin 9A into Maplewood pipe

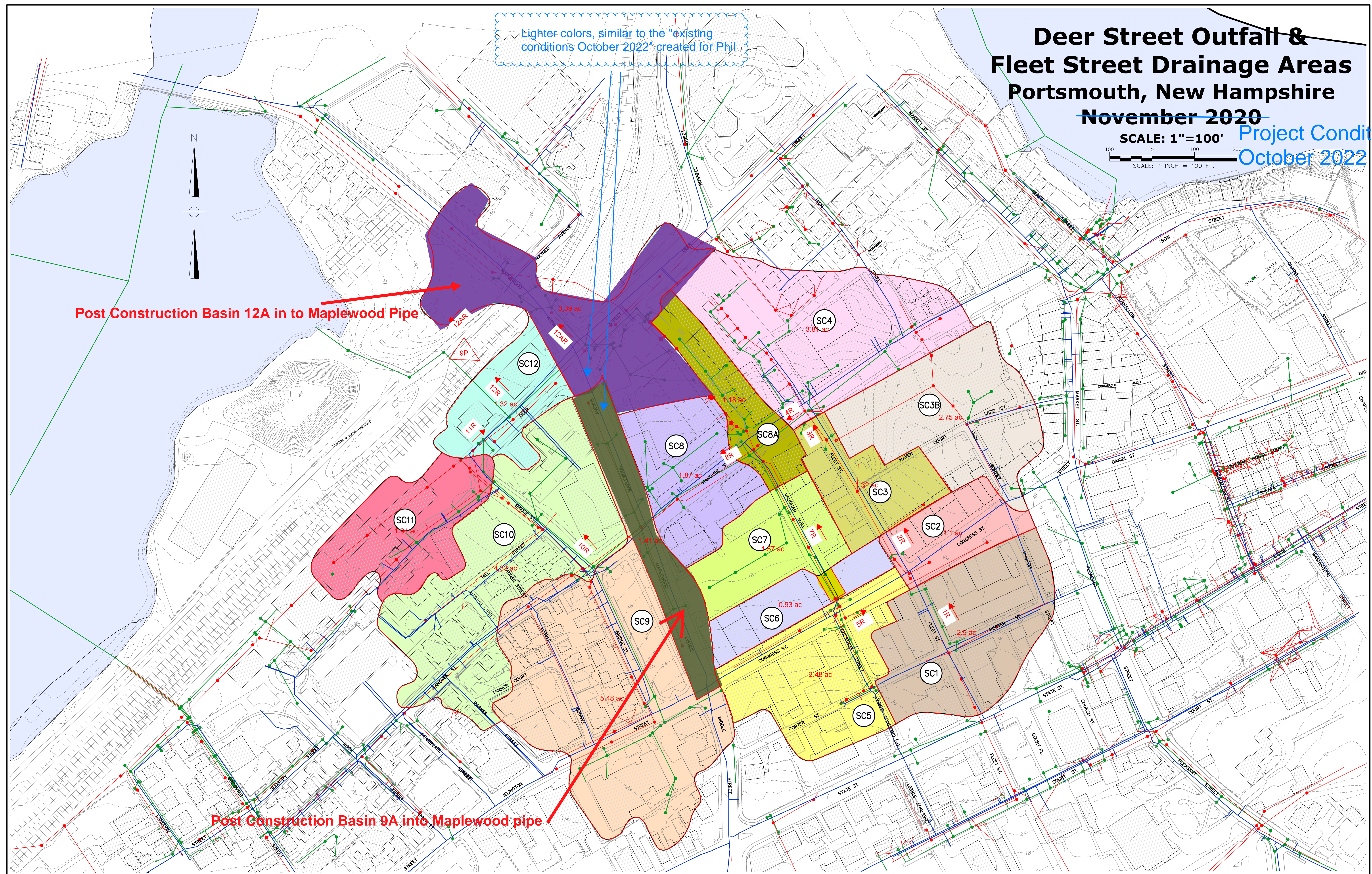

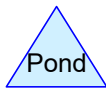
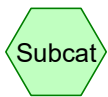
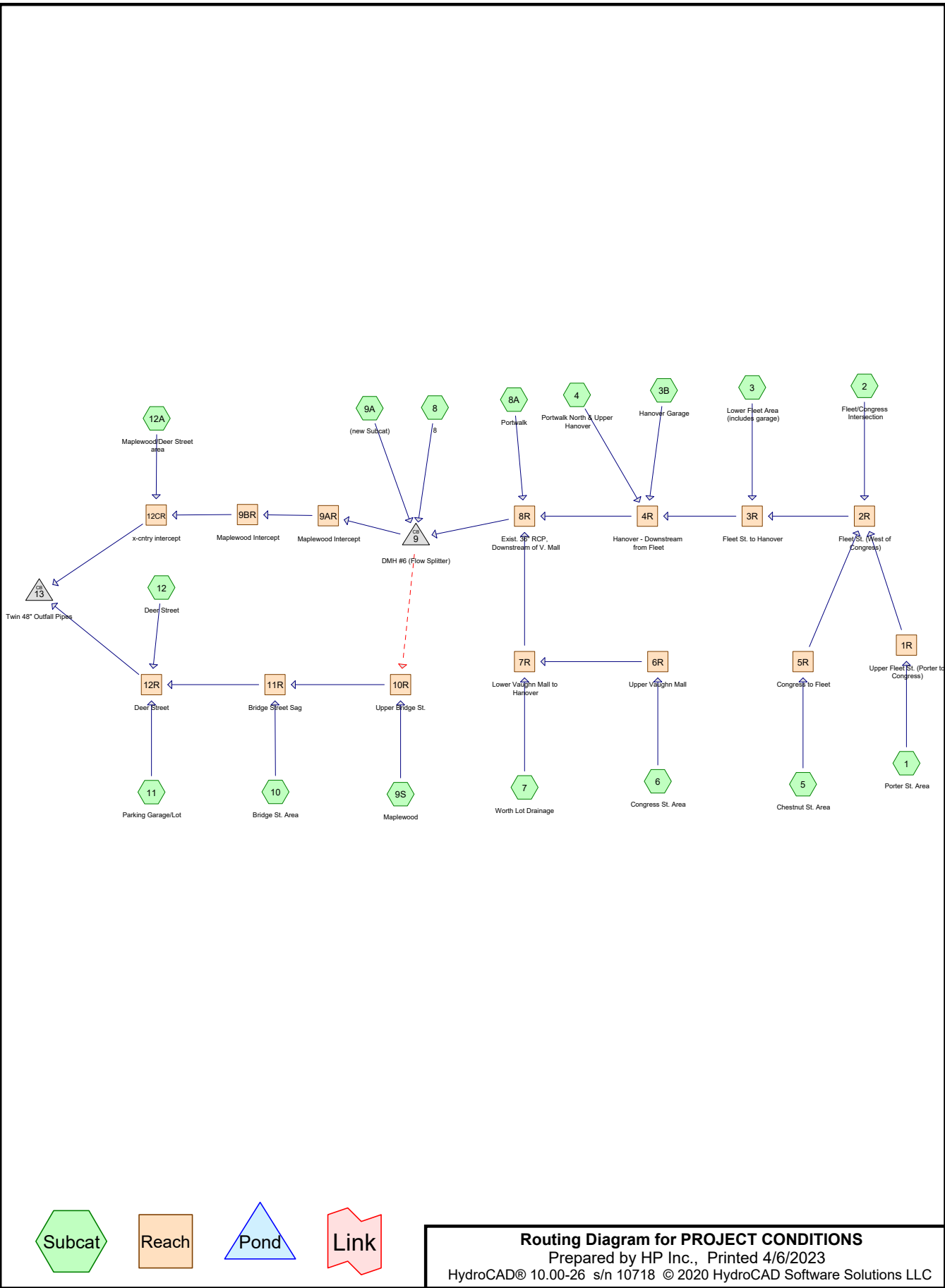

Routing Diagram for PROJECT CONDITIONS
 Prepared by HP Inc., Printed 4/6/2023
 HydroCAD® 10.00-26 s/n 10718 © 2020 HydroCAD Software Solutions LLC

PROJECT CONDITIONS

Prepared by HP Inc.

HydroCAD® 10.00-26 s/n 10718 © 2020 HydroCAD Software Solutions LLC

Type III 24-hr Rainfall=5.00"

Printed 4/6/2023

Page 2

Time span=0.00-24.00 hrs, dt=0.05 hrs, 481 points
Runoff by SCS TR-20 method, UH=SCS, Weighted-CN
Reach routing by Stor-Ind+Trans method - Pond routing by Stor-Ind method

Subcatchment1: Porter St. Area	Runoff Area=2.500 ac Runoff Depth>4.31" Tc=6.0 min CN=94 Runoff=11.47 cfs 0.897 af
Subcatchment2: Fleet/Congress Intersection	Runoff Area=1.100 ac Runoff Depth>4.53" Tc=6.0 min CN=96 Runoff=5.17 cfs 0.415 af
Subcatchment3: Lower Fleet Area (includes garage)	Runoff Area=1.300 ac Runoff Depth>4.53" Tc=6.0 min CN=96 Runoff=6.11 cfs 0.491 af
Subcatchment3B: Hanover Garage	Runoff Area=2.700 ac Runoff Depth>4.53" Tc=6.0 min CN=96 Runoff=12.69 cfs 1.019 af
Subcatchment4: Portwalk North & Upper Hanover	Runoff Area=4.100 ac Runoff Depth>4.09" Tc=8.0 min CN=92 Runoff=17.23 cfs 1.396 af
Subcatchment5: Chestnut St. Area	Runoff Area=2.100 ac Runoff Depth>4.31" Tc=6.0 min CN=94 Runoff=9.63 cfs 0.753 af
Subcatchment6: Congress St. Area	Runoff Area=1.100 ac Runoff Depth>4.31" Tc=6.0 min CN=94 Runoff=5.05 cfs 0.395 af
Subcatchment7: Worth Lot Drainage	Runoff Area=1.400 ac Runoff Depth>4.31" Tc=6.0 min CN=94 Runoff=6.42 cfs 0.502 af
Subcatchment8: 8	Runoff Area=1.800 ac Runoff Depth>4.53" Tc=6.0 min CN=96 Runoff=8.46 cfs 0.679 af
Subcatchment8A: Portwalk	Runoff Area=1.200 ac Runoff Depth>4.09" Tc=6.0 min CN=92 Runoff=5.34 cfs 0.409 af
Subcatchment9A: (new Subcat)	Runoff=0.00 cfs 0.000 af
Subcatchment9S: Maplewood	Runoff Area=6.700 ac Runoff Depth>3.66" Tc=9.0 min CN=88 Runoff=25.08 cfs 2.046 af
Subcatchment10: Bridge St. Area	Runoff Area=4.500 ac Runoff Depth>4.09" Tc=6.0 min CN=92 Runoff=20.01 cfs 1.532 af
Subcatchment11: Parking Garage/Lot	Runoff Area=2.000 ac Runoff Depth>4.31" Tc=6.0 min CN=94 Runoff=9.17 cfs 0.718 af
Subcatchment12: Deer Street	Runoff Area=1.500 ac Runoff Depth>3.27" Tc=6.0 min CN=84 Runoff=5.59 cfs 0.408 af
Subcatchment12A: Maplewood/Deer Street area	Runoff Area=3.000 ac Runoff Depth>3.27" Tc=8.0 min CN=84 Runoff=10.53 cfs 0.817 af

PROJECT CONDITIONS

Type III 24-hr Rainfall=5.00"

Prepared by HP Inc.

Printed 4/6/2023

HydroCAD® 10.00-26 s/n 10718 © 2020 HydroCAD Software Solutions LLC

Page 3

Reach 1R: Upper Fleet St. (Porter to	Avg. Flow Depth=1.23'	Max Vel=7.37 fps	Inflow=11.47 cfs	0.897 af
18.0" Round Pipe n=0.010 L=180.0' S=0.0070 '/'	Capacity=11.43 cfs	Outflow=11.27 cfs	0.897 af	
Reach 2R: Fleet St. (West of Congress)	Avg. Flow Depth=1.59'	Max Vel=9.54 fps	Inflow=25.76 cfs	2.065 af
24.0" Round Pipe n=0.010 L=380.0' S=0.0080 '/'	Capacity=26.30 cfs	Outflow=24.86 cfs	2.064 af	
Reach 3R: Fleet St. to Hanover	Avg. Flow Depth=1.72'	Max Vel=10.67 fps	Inflow=30.71 cfs	2.555 af
24.0" Round Pipe n=0.010 L=100.0' S=0.0100 '/'	Capacity=29.41 cfs	Outflow=30.45 cfs	2.554 af	
Reach 4R: Hanover - Downstream from	Avg. Flow Depth=2.42'	Max Vel=9.75 fps	Inflow=59.96 cfs	4.969 af
36.0" Round Pipe n=0.012 L=180.0' S=0.0070 '/'	Capacity=60.45 cfs	Outflow=59.02 cfs	4.968 af	
Reach 5R: Congress to Fleet	Avg. Flow Depth=1.22'	Max Vel=6.23 fps	Inflow=9.63 cfs	0.753 af
18.0" Round Pipe n=0.010 L=220.0' S=0.0050 '/'	Capacity=9.66 cfs	Outflow=9.38 cfs	0.753 af	
Reach 6R: Upper Vaughn Mall	Avg. Flow Depth=0.83'	Max Vel=5.82 fps	Inflow=5.05 cfs	0.395 af
15.0" Round Pipe n=0.013 L=200.0' S=0.0100 '/'	Capacity=6.46 cfs	Outflow=4.93 cfs	0.394 af	
Reach 7R: Lower Vaughn Mall to	Avg. Flow Depth=1.17'	Max Vel=5.93 fps	Inflow=11.31 cfs	0.897 af
24.0" Round Pipe n=0.013 L=150.0' S=0.0060 '/'	Capacity=17.52 cfs	Outflow=11.11 cfs	0.896 af	
Reach 8R: Exist. 36" RCP,	Avg. Flow Depth=2.55'	Max Vel=11.65 fps	Inflow=75.20 cfs	6.273 af
36.0" Round Pipe n=0.012 L=200.0' S=0.0100 '/'	Capacity=72.26 cfs	Outflow=74.07 cfs	6.272 af	
Reach 9AR: Maplewood Intercept	Avg. Flow Depth=2.36'	Max Vel=10.93 fps	Inflow=65.53 cfs	6.255 af
36.0" Round Pipe n=0.010 L=31.0' S=0.0061 '/'	Capacity=67.88 cfs	Outflow=65.38 cfs	6.255 af	
Reach 9BR: Maplewood Intercept	Avg. Flow Depth=2.68'	Max Vel=8.14 fps	Inflow=65.38 cfs	6.255 af
42.0" Round Pipe n=0.012 L=600.0' S=0.0040 '/'	Capacity=68.93 cfs	Outflow=62.79 cfs	6.249 af	
Reach 10R: Upper Bridge St.	Avg. Flow Depth=2.23'	Max Vel=7.31 fps	Inflow=41.55 cfs	2.742 af
36.0" Round Pipe n=0.012 L=170.0' S=0.0040 '/'	Capacity=45.70 cfs	Outflow=40.88 cfs	2.741 af	
Reach 11R: Bridge Street Sag	Avg. Flow Depth=2.61'	Max Vel=9.02 fps	Inflow=59.33 cfs	4.274 af
36.0" Round Pipe n=0.012 L=160.0' S=0.0060 '/'	Capacity=55.97 cfs	Outflow=58.29 cfs	4.273 af	
Reach 12CR: x-cntry intercept	Avg. Flow Depth=3.41'	Max Vel=6.31 fps	Inflow=72.44 cfs	7.066 af
48.0" Round Pipe n=0.012 L=210.0' S=0.0020 '/'	Capacity=69.59 cfs	Outflow=71.03 cfs	7.062 af	
Reach 12R: Deer Street	Avg. Flow Depth=3.39'	Max Vel=6.31 fps	Inflow=72.39 cfs	5.399 af
48.0" Round Pipe n=0.012 L=160.0' S=0.0020 '/'	Capacity=69.59 cfs	Outflow=70.96 cfs	5.397 af	
Pond 9: DMH #6 (Flow Splitter)	Peak Elev=9.69'	Inflow=82.02 cfs	6.951 af	
Primary=65.53 cfs 6.255 af Secondary=16.49 cfs 0.696 af	Outflow=82.02 cfs	6.951 af		
Pond 13: Twin 48" Outfall Pipes	Peak Elev=6.46'	Inflow=140.28 cfs	12.459 af	
48.0" Round Culvert x 2.00 n=0.012 L=360.0' S=0.0020 '/'	Outflow=140.28 cfs	12.459 af		

PROJECT CONDITIONS

Prepared by HP Inc.

HydroCAD® 10.00-26 s/n 10718 © 2020 HydroCAD Software Solutions LLC

Type III 24-hr Rainfall=5.00"

Printed 4/6/2023

Page 4

Summary for Subcatchment 1: Porter St. Area

Runoff = 11.47 cfs @ 12.09 hrs, Volume= 0.897 af, Depth> 4.31"

Runoff by SCS TR-20 method, UH=SCS, Weighted-CN, Time Span= 0.00-24.00 hrs, dt= 0.05 hrs
Type III 24-hr Rainfall=5.00"

Area (ac)	CN	Description
* 2.500	94	Upper Fleet St

Tc (min)	Length (feet)	Slope (ft/ft)	Velocity (ft/sec)	Capacity (cfs)	Description
6.0					Direct Entry,

Subcatchment 1: Porter St. Area

Hydrograph

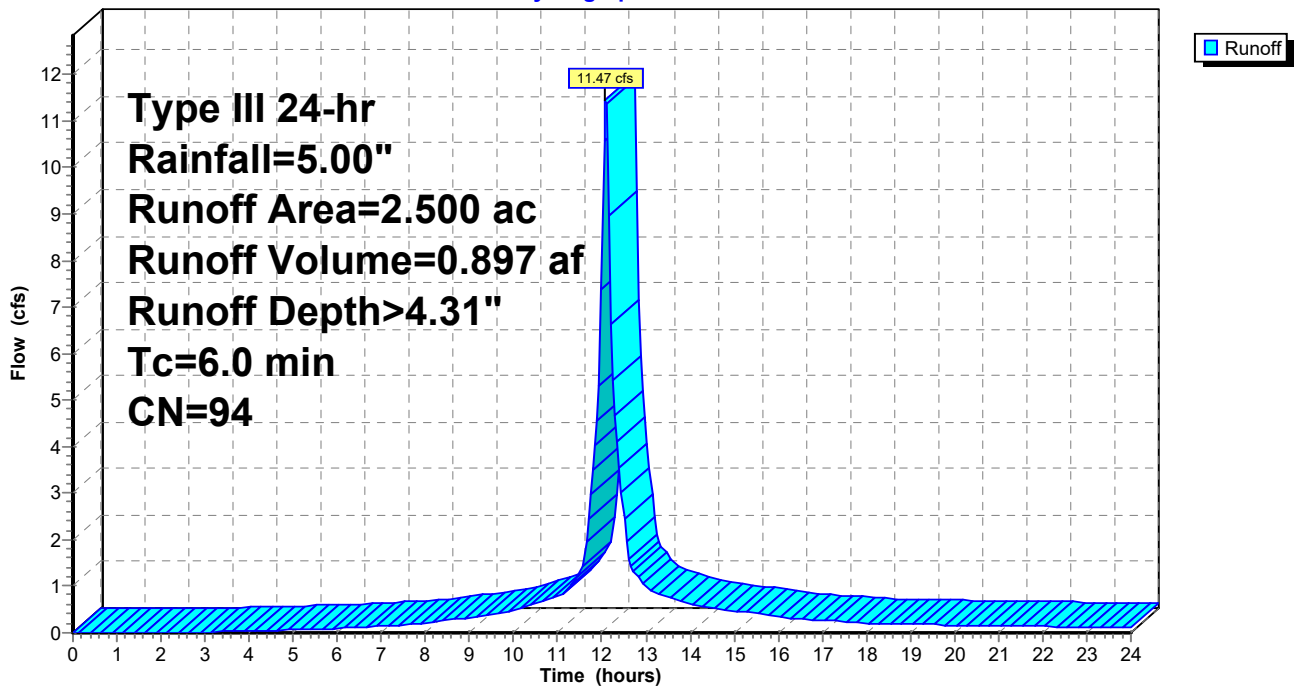

PROJECT CONDITIONS

Prepared by HP Inc.

HydroCAD® 10.00-26 s/n 10718 © 2020 HydroCAD Software Solutions LLC

Type III 24-hr Rainfall=5.00"

Printed 4/6/2023

Page 5

Summary for Subcatchment 2: Fleet/Congress Intersection

Runoff = 5.17 cfs @ 12.09 hrs, Volume= 0.415 af, Depth> 4.53"

Runoff by SCS TR-20 method, UH=SCS, Weighted-CN, Time Span= 0.00-24.00 hrs, dt= 0.05 hrs
Type III 24-hr Rainfall=5.00"

Area (ac)	CN	Description
* 1.100	96	

Tc (min)	Length (feet)	Slope (ft/ft)	Velocity (ft/sec)	Capacity (cfs)	Description
6.0					Direct Entry,

Subcatchment 2: Fleet/Congress Intersection

Hydrograph

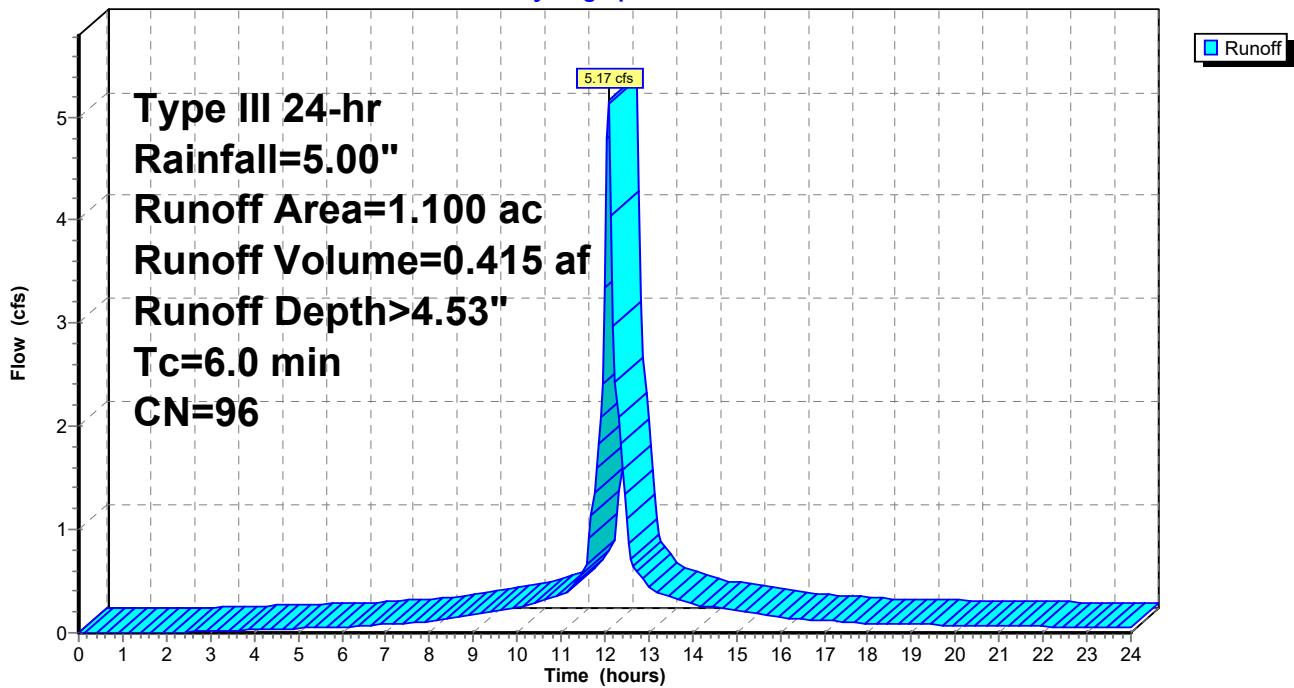

PROJECT CONDITIONS

Prepared by HP Inc.

HydroCAD® 10.00-26 s/n 10718 © 2020 HydroCAD Software Solutions LLC

Type III 24-hr Rainfall=5.00"

Printed 4/6/2023

Page 6

Summary for Subcatchment 3: Lower Fleet Area (includes garage)

Runoff = 6.11 cfs @ 12.09 hrs, Volume= 0.491 af, Depth> 4.53"

Runoff by SCS TR-20 method, UH=SCS, Weighted-CN, Time Span= 0.00-24.00 hrs, dt= 0.05 hrs
Type III 24-hr Rainfall=5.00"

Area (ac)	CN	Description
* 1.300	96	

Tc (min)	Length (feet)	Slope (ft/ft)	Velocity (ft/sec)	Capacity (cfs)	Description
6.0					Direct Entry,

Subcatchment 3: Lower Fleet Area (includes garage)

Hydrograph

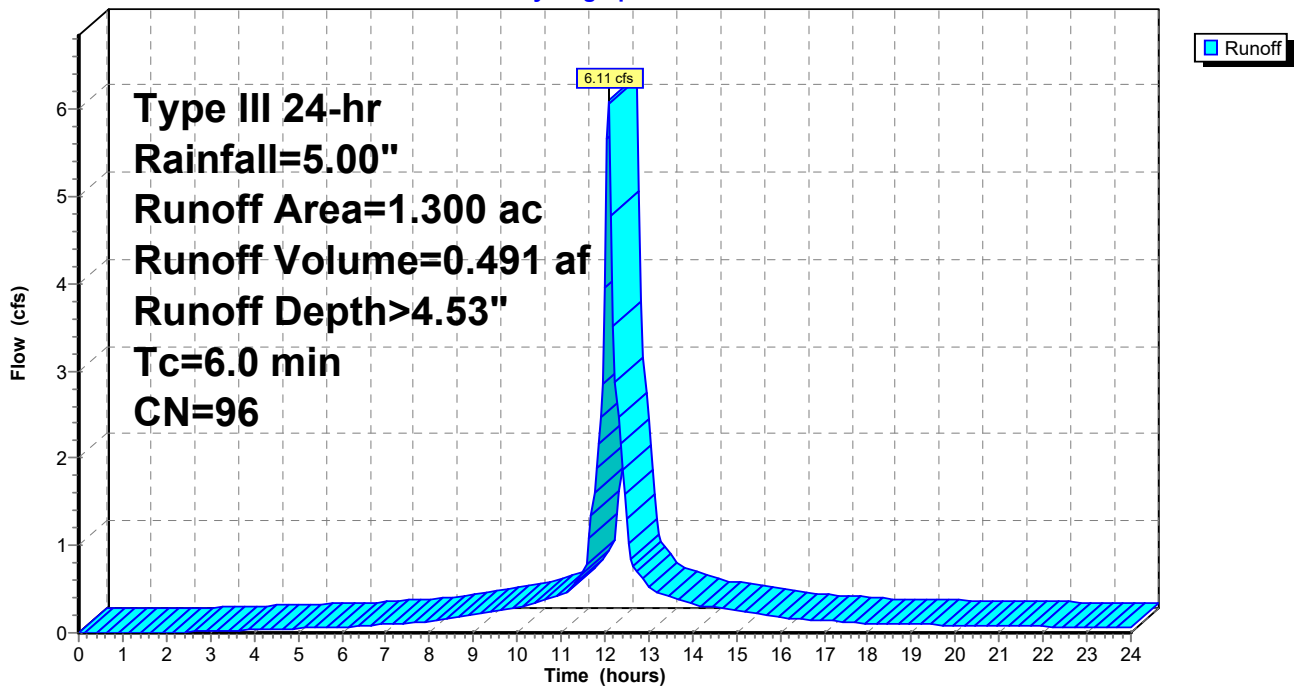

PROJECT CONDITIONS

Prepared by HP Inc.

HydroCAD® 10.00-26 s/n 10718 © 2020 HydroCAD Software Solutions LLC

Type III 24-hr Rainfall=5.00"

Printed 4/6/2023

Page 7

Summary for Subcatchment 3B: Hanover Garage

Runoff = 12.69 cfs @ 12.09 hrs, Volume= 1.019 af, Depth> 4.53"

Runoff by SCS TR-20 method, UH=SCS, Weighted-CN, Time Span= 0.00-24.00 hrs, dt= 0.05 hrs
Type III 24-hr Rainfall=5.00"

Area (ac)	CN	Description
* 2.700	96	

Tc (min)	Length (feet)	Slope (ft/ft)	Velocity (ft/sec)	Capacity (cfs)	Description
6.0					Direct Entry, minimum

Subcatchment 3B: Hanover Garage

Hydrograph

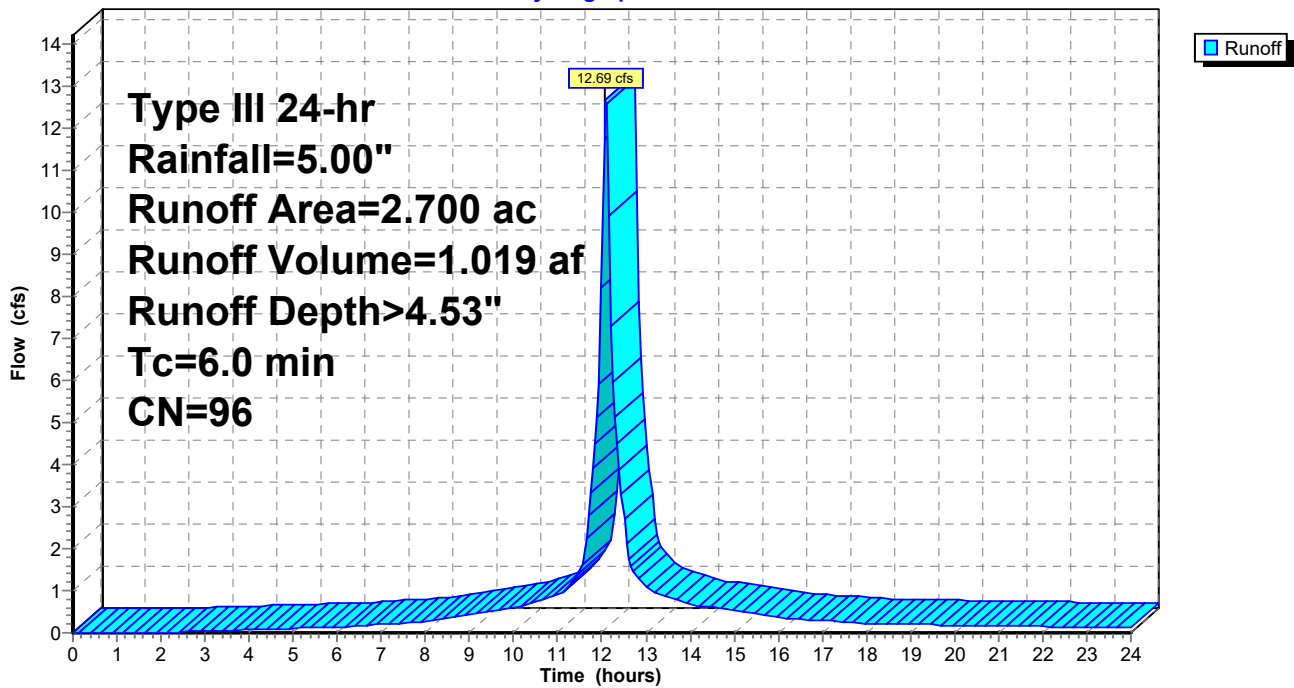

PROJECT CONDITIONS

Prepared by HP Inc.

HydroCAD® 10.00-26 s/n 10718 © 2020 HydroCAD Software Solutions LLC

Type III 24-hr Rainfall=5.00"

Printed 4/6/2023

Page 8

Summary for Subcatchment 4: Portwalk North & Upper Hanover

Runoff = 17.23 cfs @ 12.11 hrs, Volume= 1.396 af, Depth> 4.09"

Runoff by SCS TR-20 method, UH=SCS, Weighted-CN, Time Span= 0.00-24.00 hrs, dt= 0.05 hrs
Type III 24-hr Rainfall=5.00"

Area (ac)	CN	Description
* 4.100	92	

Tc (min)	Length (feet)	Slope (ft/ft)	Velocity (ft/sec)	Capacity (cfs)	Description
8.0					Direct Entry,

Subcatchment 4: Portwalk North & Upper Hanover

Hydrograph

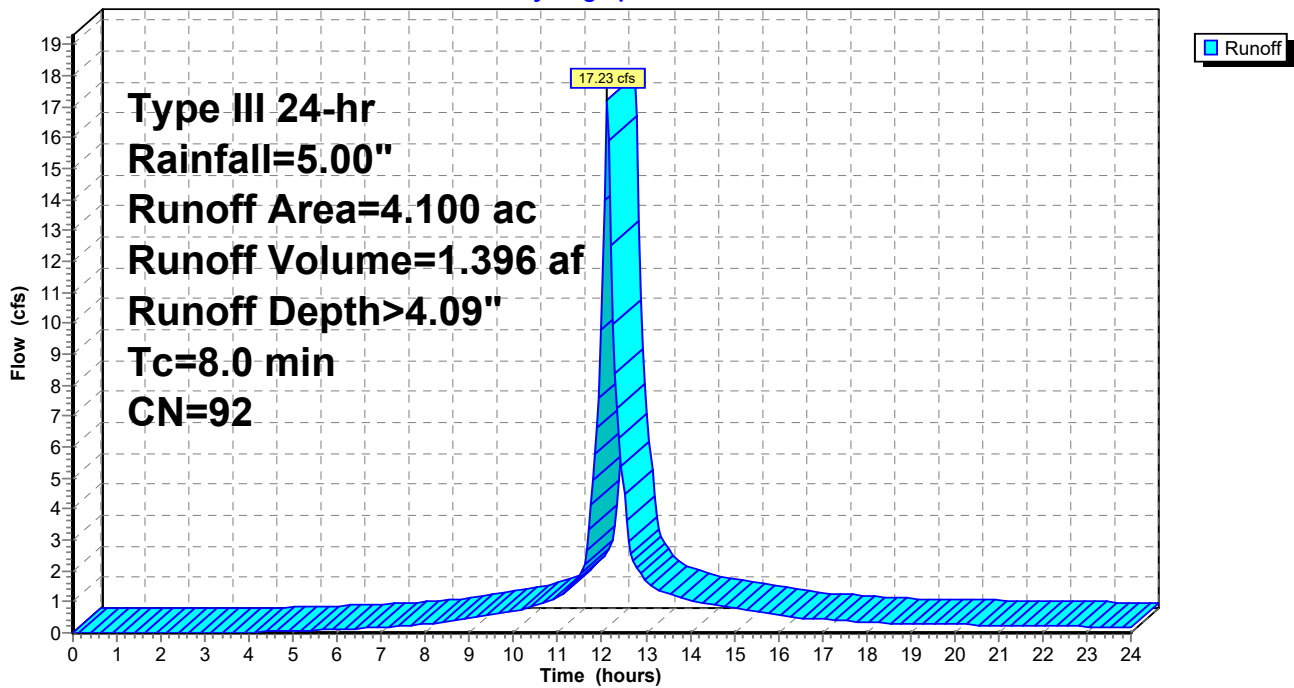

PROJECT CONDITIONS

Prepared by HP Inc.

HydroCAD® 10.00-26 s/n 10718 © 2020 HydroCAD Software Solutions LLC

Type III 24-hr Rainfall=5.00"

Printed 4/6/2023

Page 9

Summary for Subcatchment 5: Chestnut St. Area

Runoff = 9.63 cfs @ 12.09 hrs, Volume= 0.753 af, Depth> 4.31"

Runoff by SCS TR-20 method, UH=SCS, Weighted-CN, Time Span= 0.00-24.00 hrs, dt= 0.05 hrs
Type III 24-hr Rainfall=5.00"

Area (ac)	CN	Description
* 2.100	94	

Tc (min)	Length (feet)	Slope (ft/ft)	Velocity (ft/sec)	Capacity (cfs)	Description
6.0					Direct Entry,

Subcatchment 5: Chestnut St. Area

Hydrograph

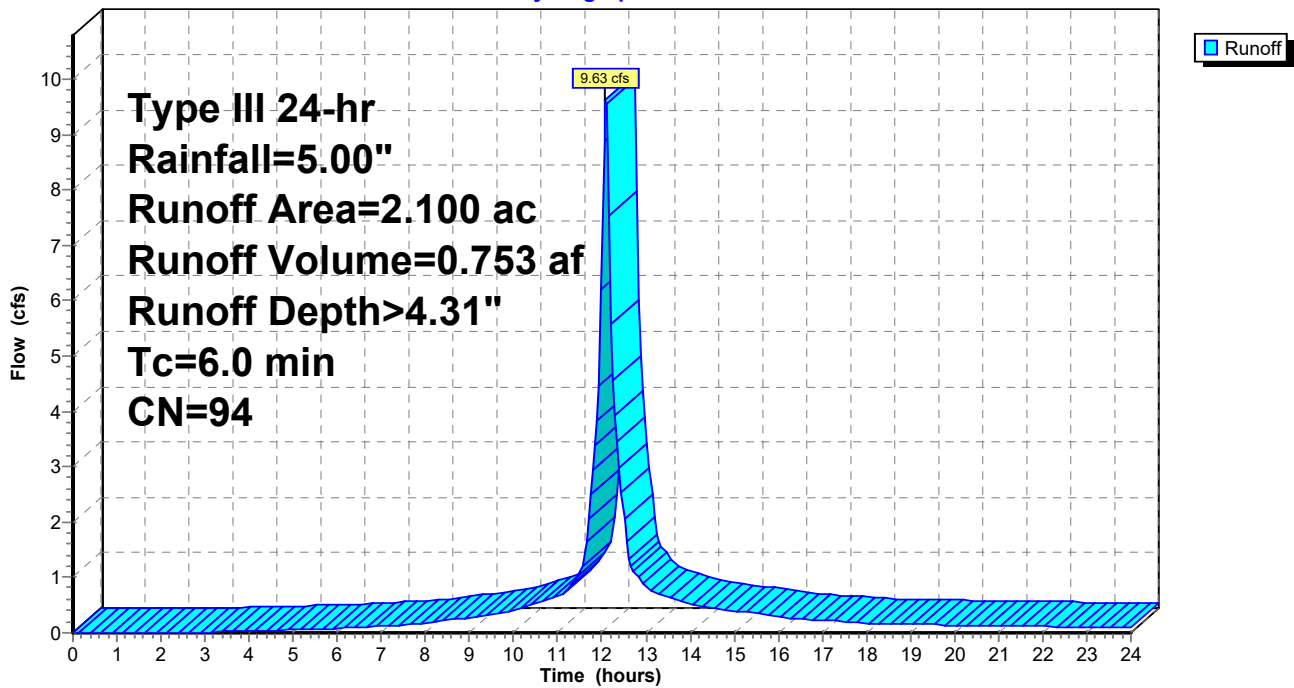

PROJECT CONDITIONS

Prepared by HP Inc.

HydroCAD® 10.00-26 s/n 10718 © 2020 HydroCAD Software Solutions LLC

Type III 24-hr Rainfall=5.00"

Printed 4/6/2023

Page 10

Summary for Subcatchment 6: Congress St. Area

Runoff = 5.05 cfs @ 12.09 hrs, Volume= 0.395 af, Depth> 4.31"

Runoff by SCS TR-20 method, UH=SCS, Weighted-CN, Time Span= 0.00-24.00 hrs, dt= 0.05 hrs
Type III 24-hr Rainfall=5.00"

Area (ac)	CN	Description
* 1.100	94	

Tc (min)	Length (feet)	Slope (ft/ft)	Velocity (ft/sec)	Capacity (cfs)	Description
6.0					Direct Entry,

Subcatchment 6: Congress St. Area

Hydrograph

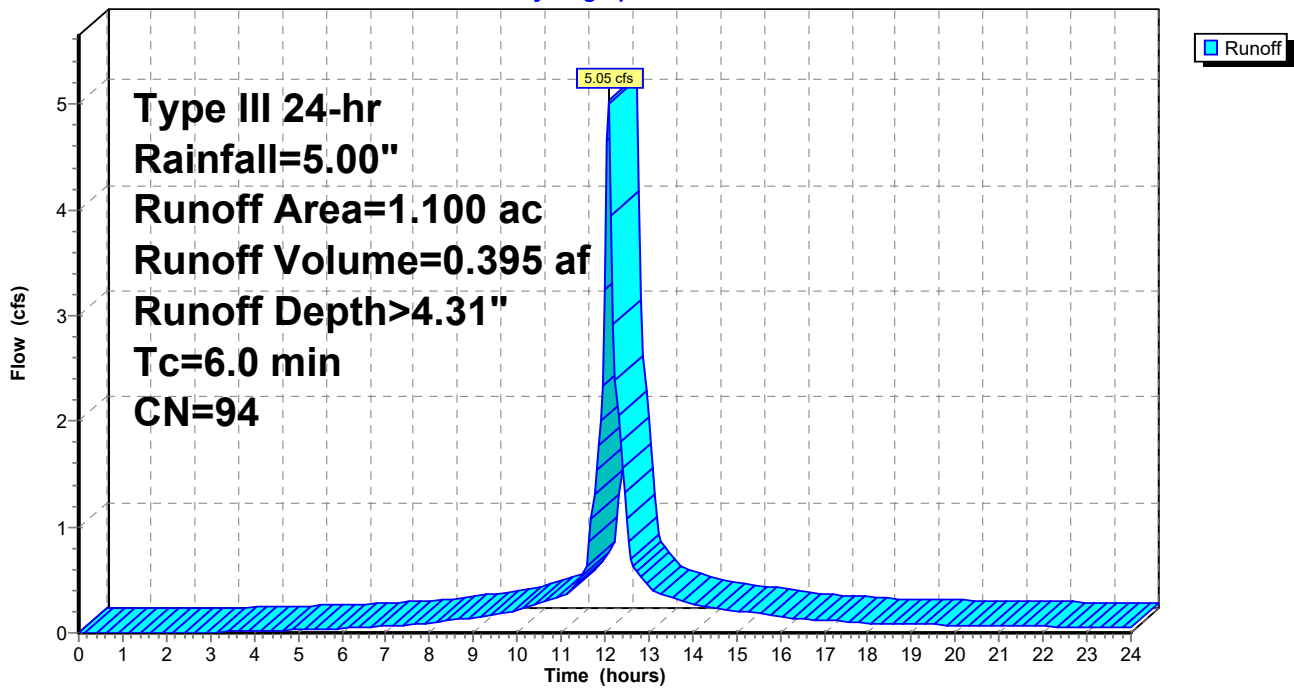

PROJECT CONDITIONS

Prepared by HP Inc.

HydroCAD® 10.00-26 s/n 10718 © 2020 HydroCAD Software Solutions LLC

Type III 24-hr Rainfall=5.00"

Printed 4/6/2023

Page 11

Summary for Subcatchment 7: Worth Lot Drainage

Runoff = 6.42 cfs @ 12.09 hrs, Volume= 0.502 af, Depth> 4.31"

Runoff by SCS TR-20 method, UH=SCS, Weighted-CN, Time Span= 0.00-24.00 hrs, dt= 0.05 hrs
Type III 24-hr Rainfall=5.00"

Area (ac)	CN	Description
* 1.400	94	

Tc (min)	Length (feet)	Slope (ft/ft)	Velocity (ft/sec)	Capacity (cfs)	Description
6.0					Direct Entry,

Subcatchment 7: Worth Lot Drainage

Hydrograph

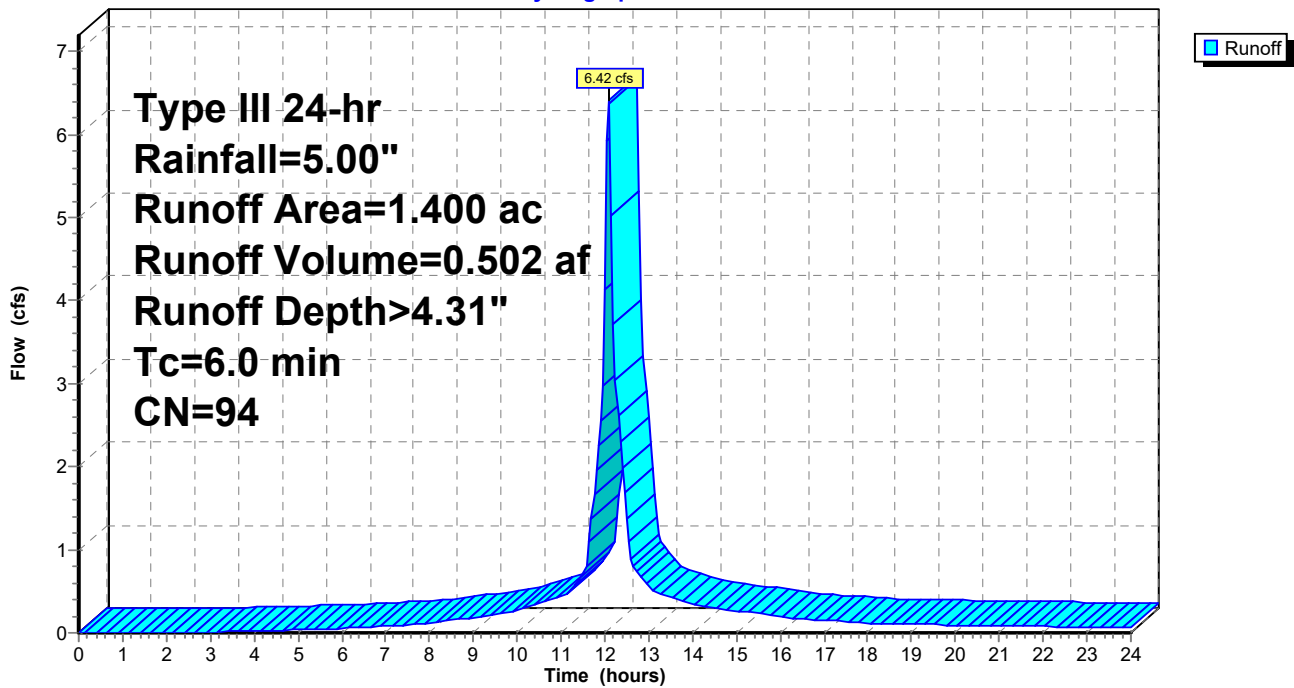

PROJECT CONDITIONS

Prepared by HP Inc.

HydroCAD® 10.00-26 s/n 10718 © 2020 HydroCAD Software Solutions LLC

Type III 24-hr Rainfall=5.00"

Printed 4/6/2023

Page 12

Summary for Subcatchment 8: 8

Runoff = 8.46 cfs @ 12.09 hrs, Volume= 0.679 af, Depth> 4.53"

Runoff by SCS TR-20 method, UH=SCS, Weighted-CN, Time Span= 0.00-24.00 hrs, dt= 0.05 hrs
Type III 24-hr Rainfall=5.00"

Area (ac)	CN	Description
* 1.800	96	

Tc (min)	Length (feet)	Slope (ft/ft)	Velocity (ft/sec)	Capacity (cfs)	Description
6.0					Direct Entry,

Subcatchment 8: 8

Hydrograph

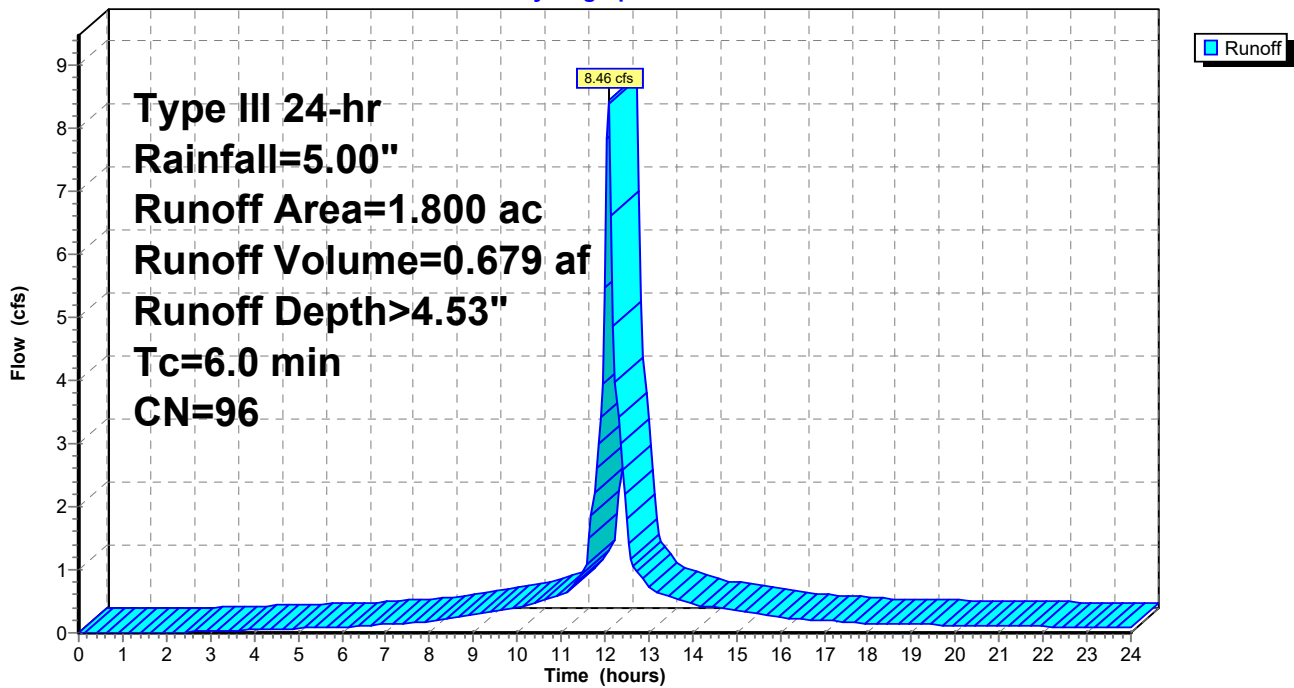

PROJECT CONDITIONS

Prepared by HP Inc.

HydroCAD® 10.00-26 s/n 10718 © 2020 HydroCAD Software Solutions LLC

Type III 24-hr Rainfall=5.00"

Printed 4/6/2023

Page 13

Summary for Subcatchment 8A: Portwalk

Runoff = 5.34 cfs @ 12.09 hrs, Volume= 0.409 af, Depth> 4.09"

Runoff by SCS TR-20 method, UH=SCS, Weighted-CN, Time Span= 0.00-24.00 hrs, dt= 0.05 hrs
Type III 24-hr Rainfall=5.00"

Area (ac)	CN	Description
* 1.200	92	

Tc (min)	Length (feet)	Slope (ft/ft)	Velocity (ft/sec)	Capacity (cfs)	Description
6.0					Direct Entry,

Subcatchment 8A: Portwalk

Hydrograph

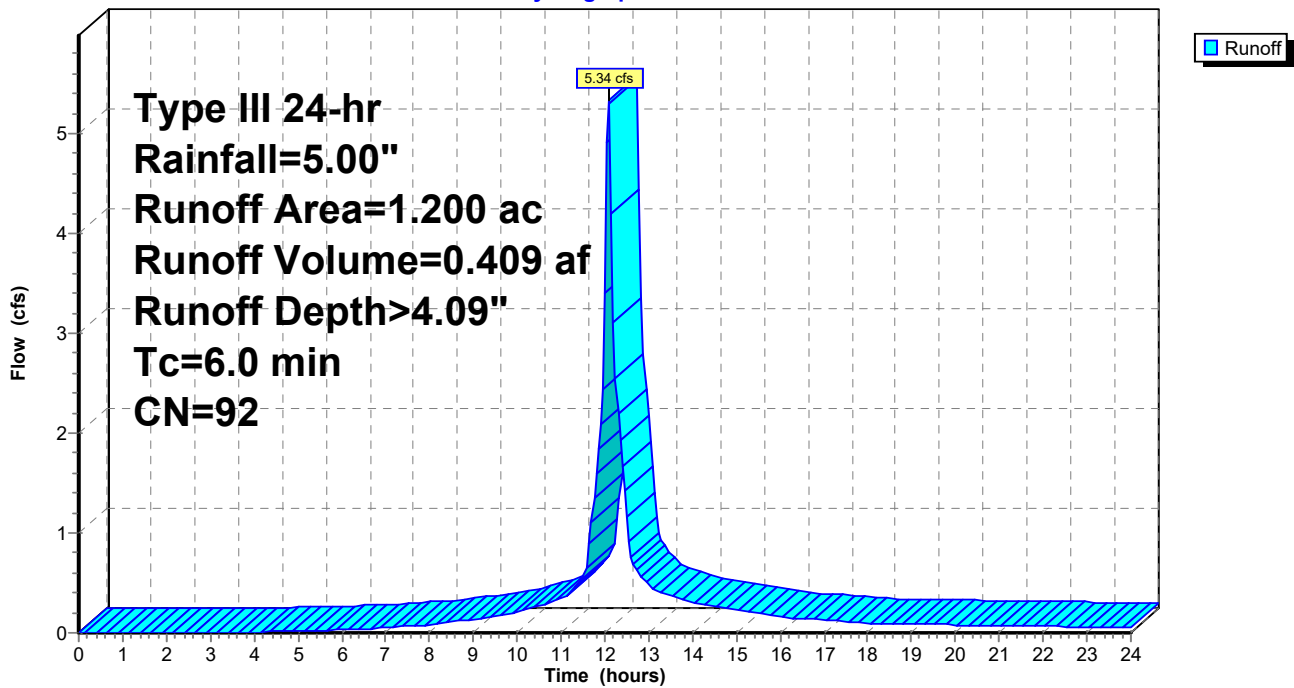

PROJECT CONDITIONS

Prepared by HP Inc.

HydroCAD® 10.00-26 s/n 10718 © 2020 HydroCAD Software Solutions LLC

Type III 24-hr Rainfall=5.00"

Printed 4/6/2023

Page 14

Summary for Subcatchment 9A: (new Subcat)

Runoff = 0.00 cfs @ 0.00 hrs, Volume= 0.000 af, Depth= 0.00"

Runoff by SCS TR-20 method, UH=SCS, Weighted-CN, Time Span= 0.00-24.00 hrs, dt= 0.05 hrs
Type III 24-hr Rainfall=5.00"

Subcatchment 9A: (new Subcat)

Hydrograph

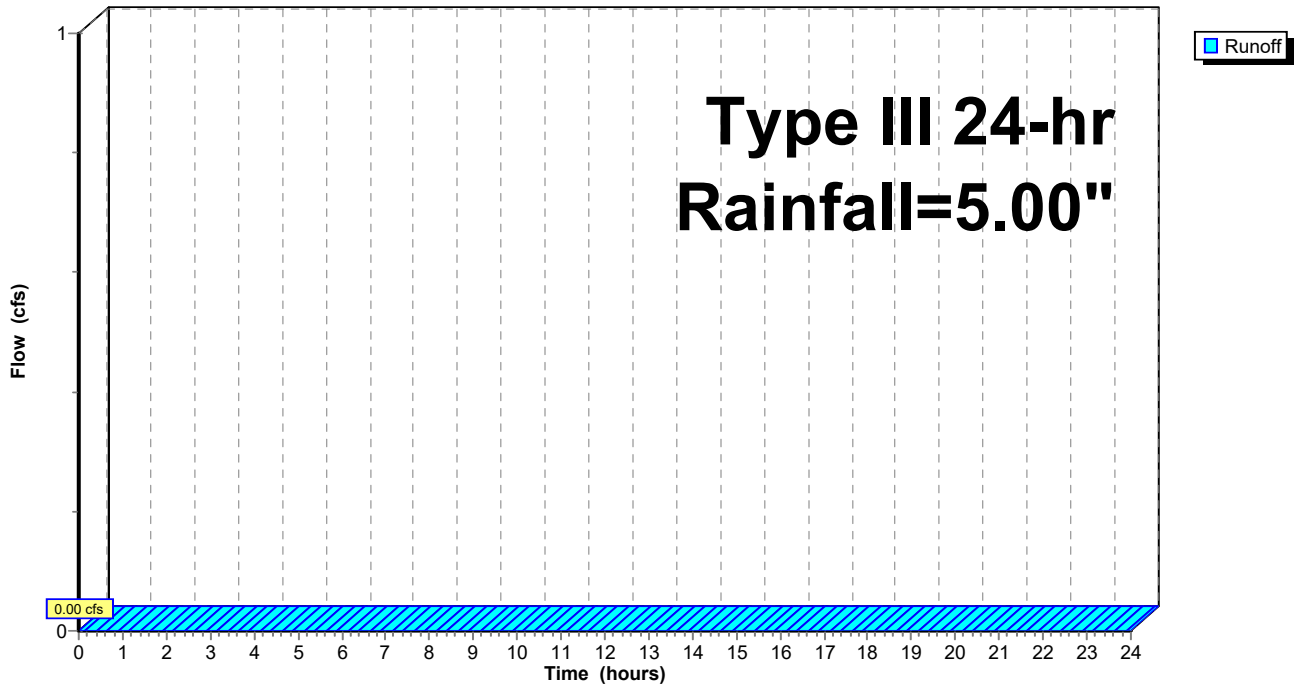

PROJECT CONDITIONS

Prepared by HP Inc.

HydroCAD® 10.00-26 s/n 10718 © 2020 HydroCAD Software Solutions LLC

Type III 24-hr Rainfall=5.00"

Printed 4/6/2023

Page 15

Summary for Subcatchment 9S: Maplewood

Runoff = 25.08 cfs @ 12.12 hrs, Volume= 2.046 af, Depth> 3.66"

Runoff by SCS TR-20 method, UH=SCS, Weighted-CN, Time Span= 0.00-24.00 hrs, dt= 0.05 hrs
Type III 24-hr Rainfall=5.00"

Area (ac)	CN	Description
* 6.700	88	

Tc (min)	Length (feet)	Slope (ft/ft)	Velocity (ft/sec)	Capacity (cfs)	Description
9.0					Direct Entry,

Subcatchment 9S: Maplewood

Hydrograph

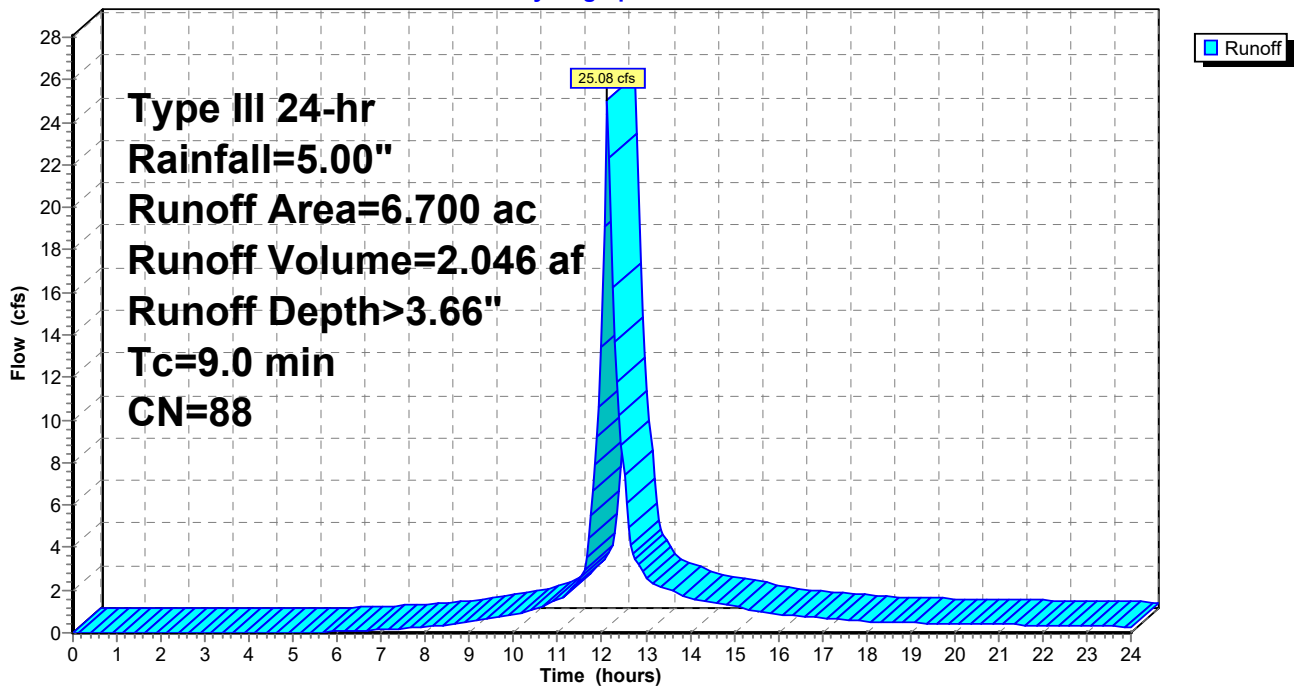

PROJECT CONDITIONS

Prepared by HP Inc.

HydroCAD® 10.00-26 s/n 10718 © 2020 HydroCAD Software Solutions LLC

Type III 24-hr Rainfall=5.00"

Printed 4/6/2023

Page 16

Summary for Subcatchment 10: Bridge St. Area

Runoff = 20.01 cfs @ 12.09 hrs, Volume= 1.532 af, Depth> 4.09"

Runoff by SCS TR-20 method, UH=SCS, Weighted-CN, Time Span= 0.00-24.00 hrs, dt= 0.05 hrs
Type III 24-hr Rainfall=5.00"

Area (ac)	CN	Description
* 4.500	92	

Tc (min)	Length (feet)	Slope (ft/ft)	Velocity (ft/sec)	Capacity (cfs)	Description
6.0					Direct Entry,

Subcatchment 10: Bridge St. Area

Hydrograph

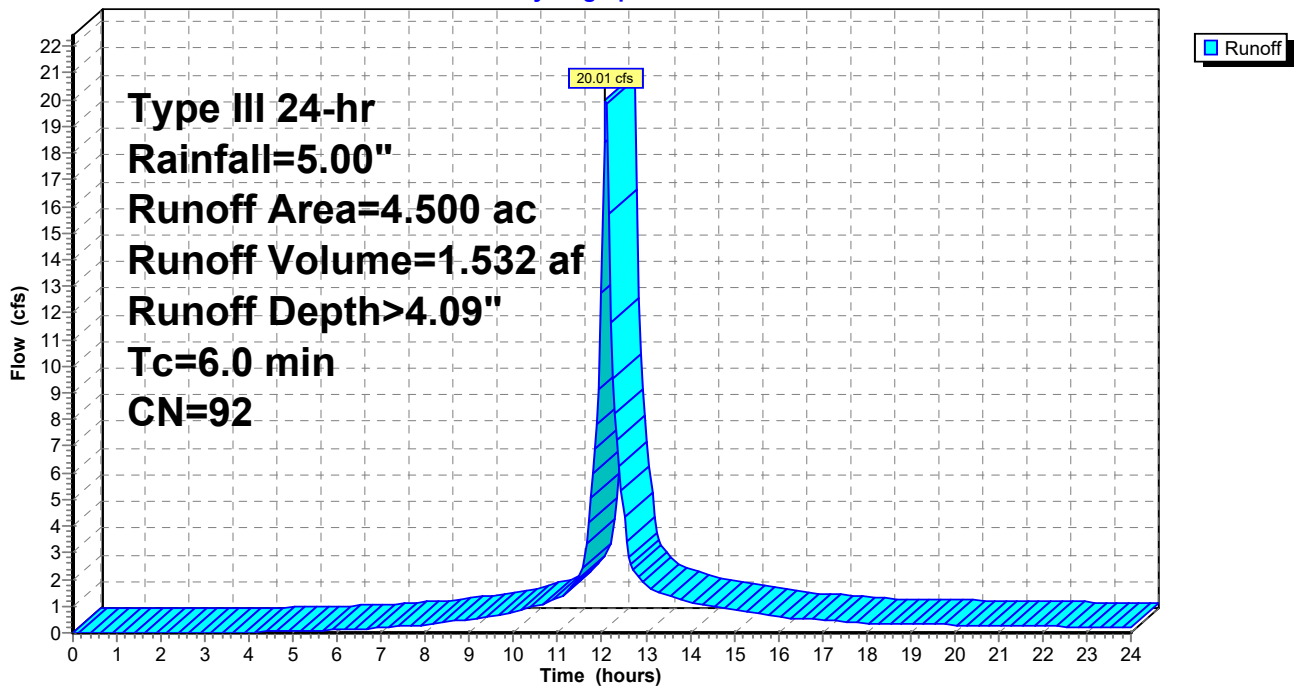

PROJECT CONDITIONS

Prepared by HP Inc.

HydroCAD® 10.00-26 s/n 10718 © 2020 HydroCAD Software Solutions LLC

Type III 24-hr Rainfall=5.00"

Printed 4/6/2023

Page 17

Summary for Subcatchment 11: Parking Garage/Lot

Runoff = 9.17 cfs @ 12.09 hrs, Volume= 0.718 af, Depth> 4.31"

Runoff by SCS TR-20 method, UH=SCS, Weighted-CN, Time Span= 0.00-24.00 hrs, dt= 0.05 hrs
Type III 24-hr Rainfall=5.00"

Area (ac)	CN	Description
* 2.000	94	

Tc (min)	Length (feet)	Slope (ft/ft)	Velocity (ft/sec)	Capacity (cfs)	Description
6.0					Direct Entry,

Subcatchment 11: Parking Garage/Lot

Hydrograph

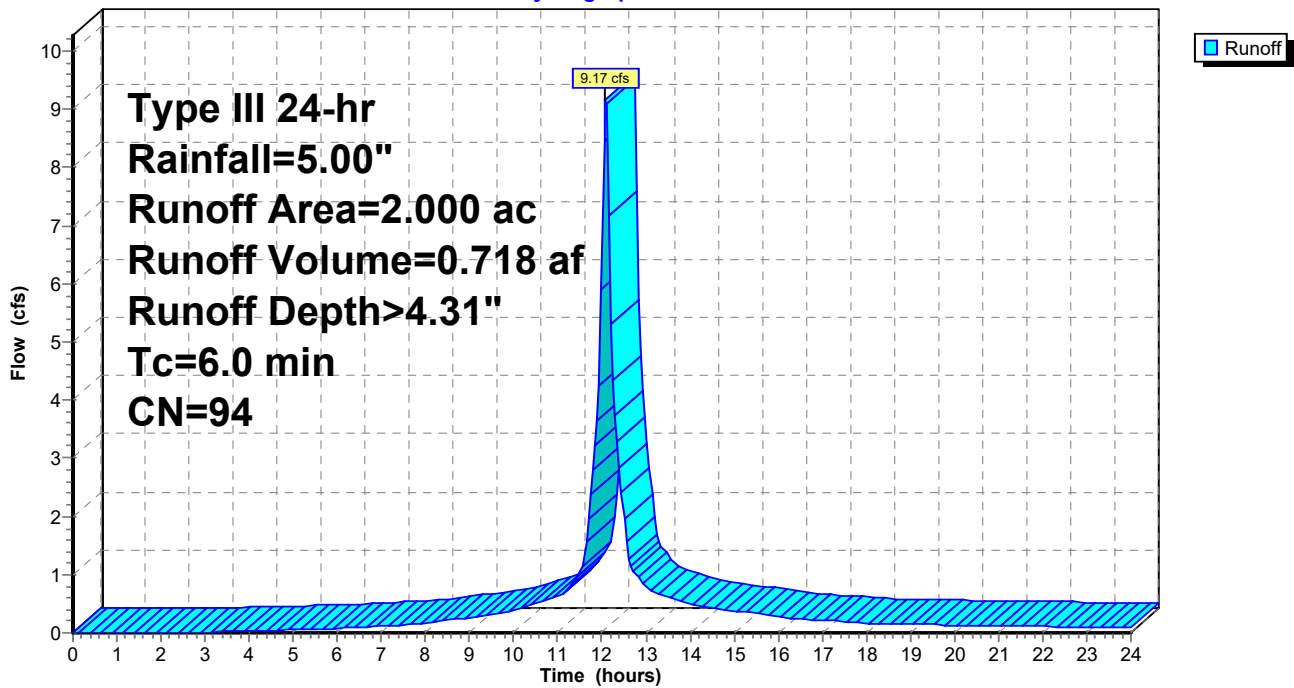

PROJECT CONDITIONS

Prepared by HP Inc.

HydroCAD® 10.00-26 s/n 10718 © 2020 HydroCAD Software Solutions LLC

Type III 24-hr Rainfall=5.00"

Printed 4/6/2023

Page 18

Summary for Subcatchment 12: Deer Street

Runoff = 5.59 cfs @ 12.09 hrs, Volume= 0.408 af, Depth> 3.27"

Runoff by SCS TR-20 method, UH=SCS, Weighted-CN, Time Span= 0.00-24.00 hrs, dt= 0.05 hrs
Type III 24-hr Rainfall=5.00"

Area (ac)	CN	Description
* 1.500	84	

Tc (min)	Length (feet)	Slope (ft/ft)	Velocity (ft/sec)	Capacity (cfs)	Description
6.0					Direct Entry,

Subcatchment 12: Deer Street

Hydrograph

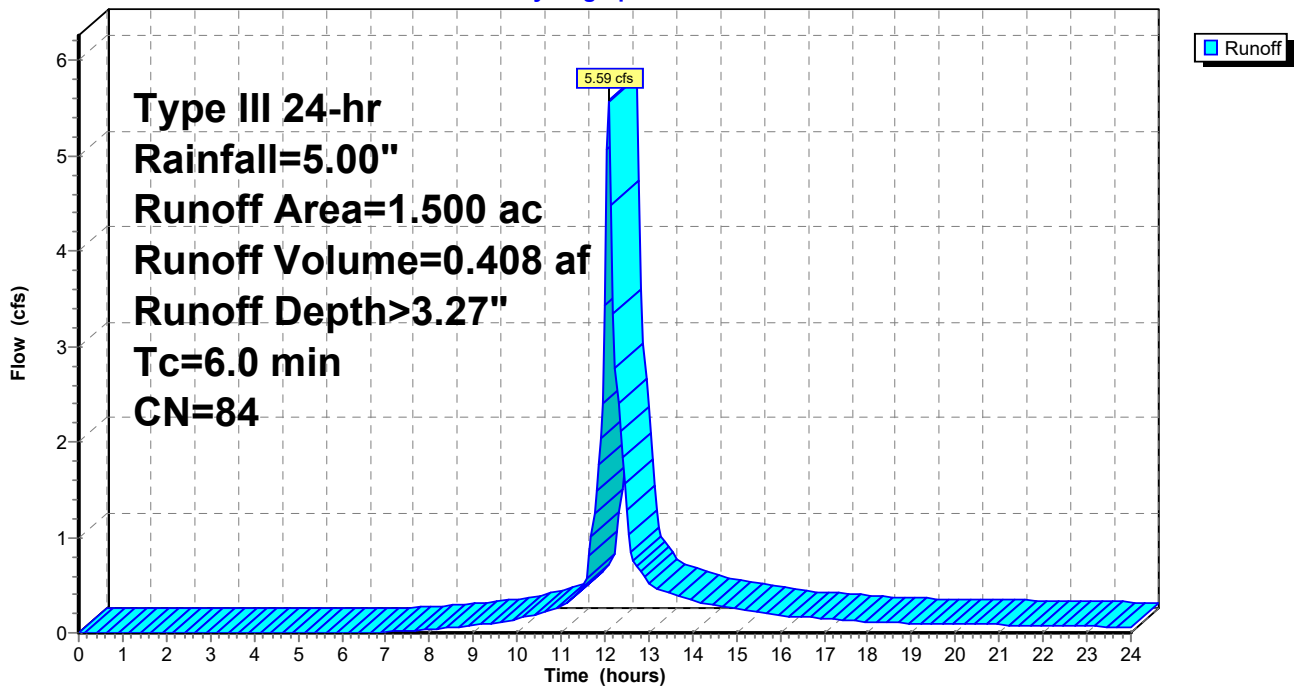

PROJECT CONDITIONS

Prepared by HP Inc.

HydroCAD® 10.00-26 s/n 10718 © 2020 HydroCAD Software Solutions LLC

Type III 24-hr Rainfall=5.00"

Printed 4/6/2023

Page 19

Summary for Subcatchment 12A: Maplewood/Deer Street area

Runoff = 10.53 cfs @ 12.11 hrs, Volume= 0.817 af, Depth> 3.27"

Runoff by SCS TR-20 method, UH=SCS, Weighted-CN, Time Span= 0.00-24.00 hrs, dt= 0.05 hrs
Type III 24-hr Rainfall=5.00"

Area (ac)	CN	Description
* 3.000	84	

Tc (min)	Length (feet)	Slope (ft/ft)	Velocity (ft/sec)	Capacity (cfs)	Description
8.0					Direct Entry,

Subcatchment 12A: Maplewood/Deer Street area

Hydrograph

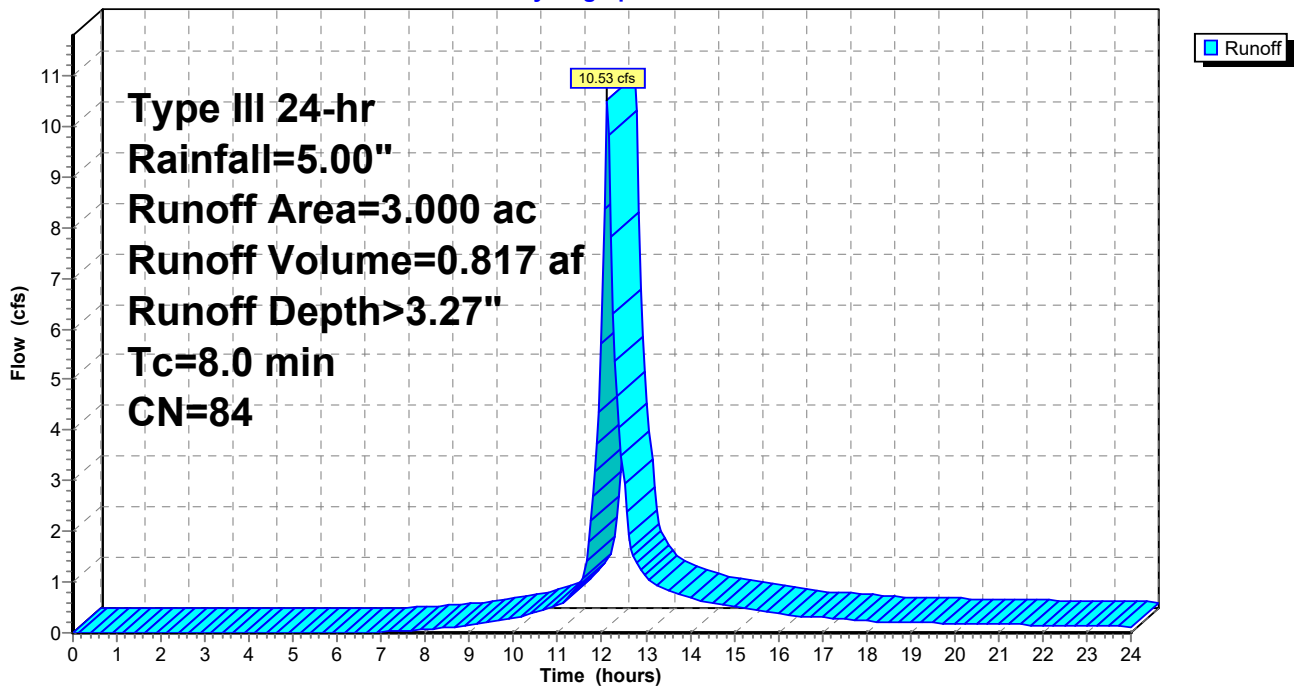

PROJECT CONDITIONS

Prepared by HP Inc.

HydroCAD® 10.00-26 s/n 10718 © 2020 HydroCAD Software Solutions LLC

Type III 24-hr Rainfall=5.00"

Printed 4/6/2023

Page 20

Summary for Reach 1R: Upper Fleet St. (Porter to Congress)

Inflow Area = 2.500 ac, Inflow Depth > 4.31"
 Inflow = 11.47 cfs @ 12.09 hrs, Volume= 0.897 af
 Outflow = 11.27 cfs @ 12.10 hrs, Volume= 0.897 af, Atten= 2%, Lag= 0.7 min

Routing by Stor-Ind+Trans method, Time Span= 0.00-24.00 hrs, dt= 0.05 hrs
 Max. Velocity= 7.37 fps, Min. Travel Time= 0.4 min
 Avg. Velocity = 2.69 fps, Avg. Travel Time= 1.1 min

Peak Storage= 280 cf @ 12.09 hrs
 Average Depth at Peak Storage= 1.23'
 Bank-Full Depth= 1.50' Flow Area= 1.8 sf, Capacity= 11.43 cfs

18.0" Round Pipe
 n= 0.010
 Length= 180.0' Slope= 0.0070 '/'
 Inlet Invert= 0.00', Outlet Invert= -1.26'

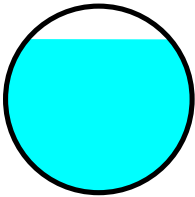

Reach 1R: Upper Fleet St. (Porter to Congress)

Hydrograph

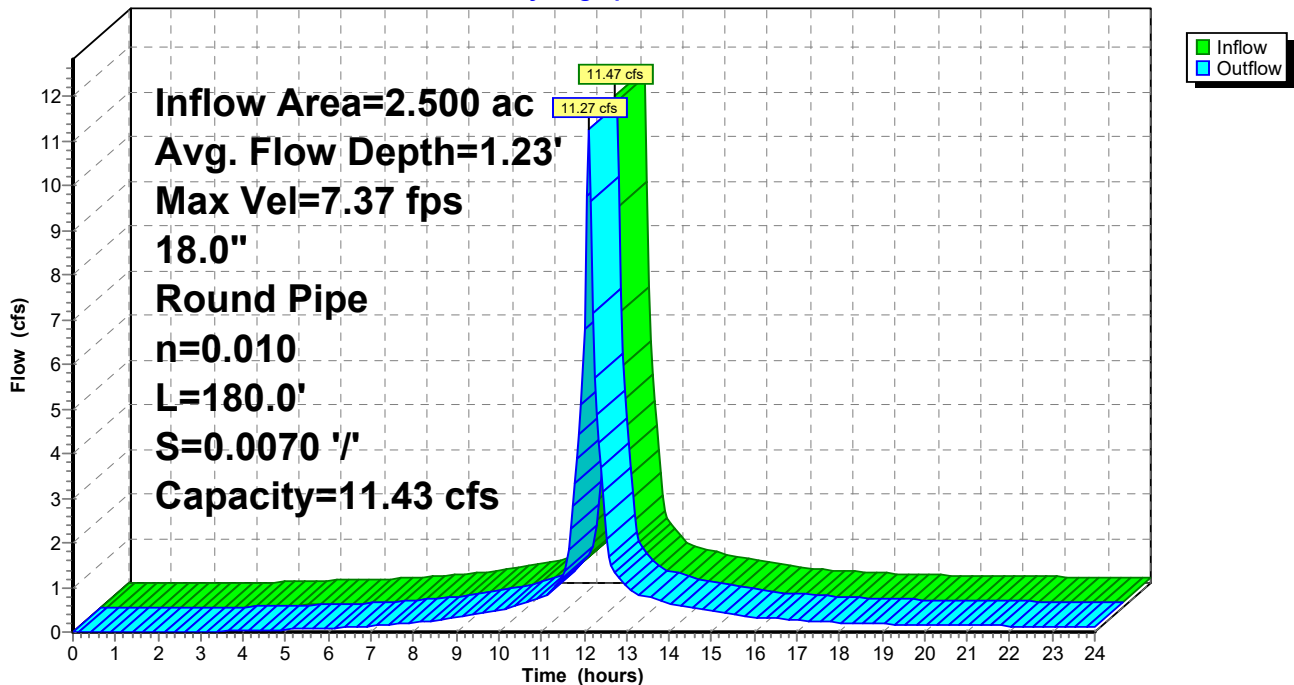

PROJECT CONDITIONS

Prepared by HP Inc.

HydroCAD® 10.00-26 s/n 10718 © 2020 HydroCAD Software Solutions LLC

Type III 24-hr Rainfall=5.00"

Printed 4/6/2023

Page 21

Summary for Reach 2R: Fleet St. (West of Congress)

Inflow Area = 5.700 ac, Inflow Depth > 4.35"
 Inflow = 25.76 cfs @ 12.10 hrs, Volume= 2.065 af
 Outflow = 24.86 cfs @ 12.12 hrs, Volume= 2.064 af, Atten= 4%, Lag= 1.2 min

Routing by Stor-Ind+Trans method, Time Span= 0.00-24.00 hrs, dt= 0.05 hrs
 Max. Velocity= 9.54 fps, Min. Travel Time= 0.7 min
 Avg. Velocity = 3.40 fps, Avg. Travel Time= 1.9 min

Peak Storage= 1,017 cf @ 12.11 hrs
 Average Depth at Peak Storage= 1.59'
 Bank-Full Depth= 2.00' Flow Area= 3.1 sf, Capacity= 26.30 cfs

24.0" Round Pipe
 n= 0.010
 Length= 380.0' Slope= 0.0080 '/'
 Inlet Invert= 0.00', Outlet Invert= -3.04'

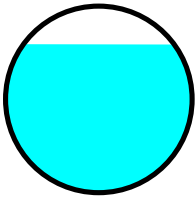

Reach 2R: Fleet St. (West of Congress)

Hydrograph

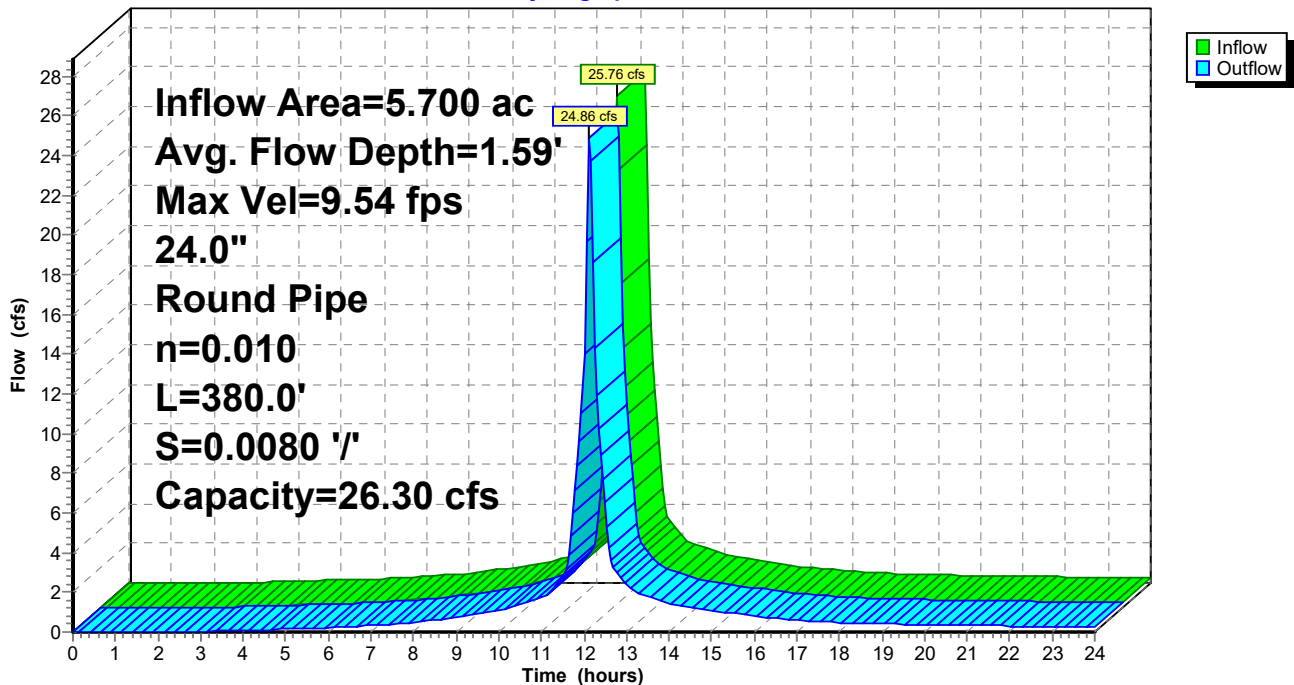

PROJECT CONDITIONS

Prepared by HP Inc.

HydroCAD® 10.00-26 s/n 10718 © 2020 HydroCAD Software Solutions LLC

Type III 24-hr Rainfall=5.00"

Printed 4/6/2023

Page 22

Summary for Reach 3R: Fleet St. to Hanover

Inflow Area = 7.000 ac, Inflow Depth > 4.38"
Inflow = 30.71 cfs @ 12.11 hrs, Volume= 2.555 af
Outflow = 30.45 cfs @ 12.12 hrs, Volume= 2.554 af, Atten= 1%, Lag= 0.3 min

Routing by Stor-Ind+Trans method, Time Span= 0.00-24.00 hrs, dt= 0.05 hrs
Max. Velocity= 10.67 fps, Min. Travel Time= 0.2 min
Avg. Velocity = 3.92 fps, Avg. Travel Time= 0.4 min

Peak Storage= 288 cf @ 12.11 hrs
Average Depth at Peak Storage= 1.72'
Bank-Full Depth= 2.00' Flow Area= 3.1 sf, Capacity= 29.41 cfs

24.0" Round Pipe
n= 0.010
Length= 100.0' Slope= 0.0100 '/'
Inlet Invert= 0.00', Outlet Invert= -1.00'

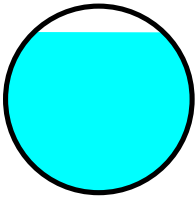

Reach 3R: Fleet St. to Hanover

Hydrograph

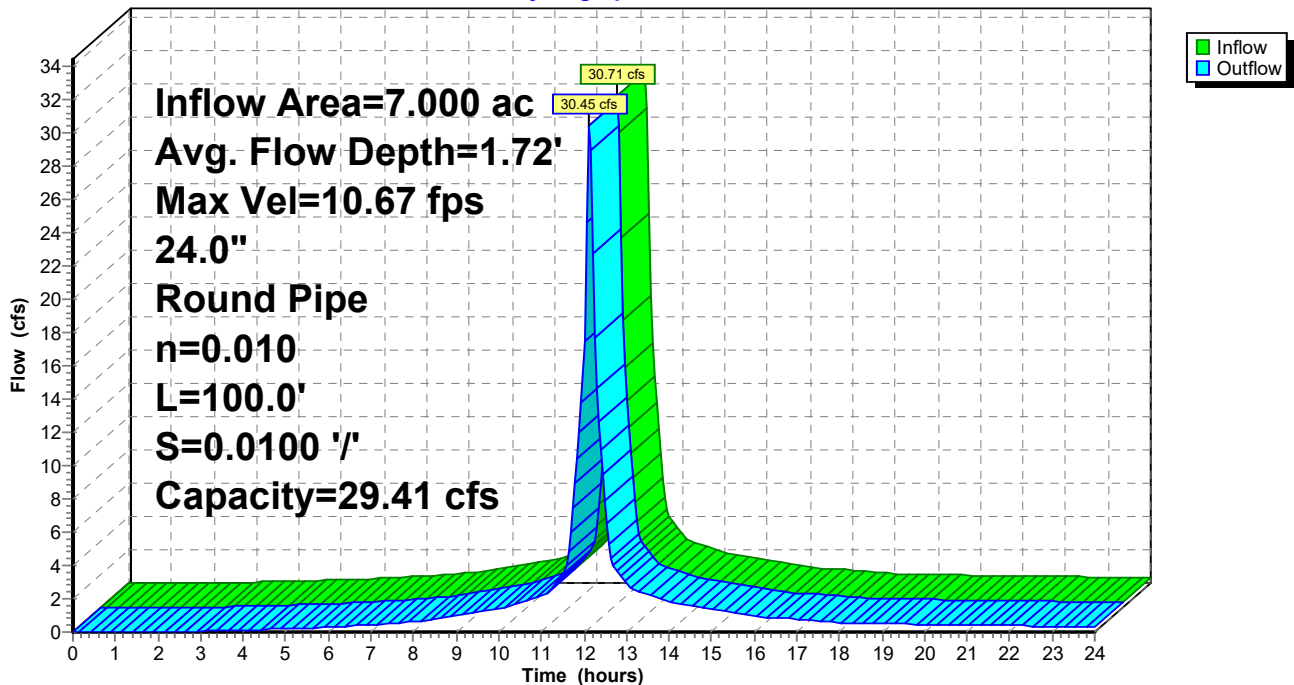

PROJECT CONDITIONS

Prepared by HP Inc.

HydroCAD® 10.00-26 s/n 10718 © 2020 HydroCAD Software Solutions LLC

Type III 24-hr Rainfall=5.00"

Printed 4/6/2023

Page 23

Summary for Reach 4R: Hanover - Downstream from Fleet

Inflow Area = 13.800 ac, Inflow Depth > 4.32"
 Inflow = 59.96 cfs @ 12.11 hrs, Volume= 4.969 af
 Outflow = 59.02 cfs @ 12.12 hrs, Volume= 4.968 af, Atten= 2%, Lag= 0.6 min

Routing by Stor-Ind+Trans method, Time Span= 0.00-24.00 hrs, dt= 0.05 hrs
 Max. Velocity= 9.75 fps, Min. Travel Time= 0.3 min
 Avg. Velocity = 3.52 fps, Avg. Travel Time= 0.9 min

Peak Storage= 1,102 cf @ 12.11 hrs
 Average Depth at Peak Storage= 2.42'
 Bank-Full Depth= 3.00' Flow Area= 7.1 sf, Capacity= 60.45 cfs

36.0" Round Pipe
 n= 0.012
 Length= 180.0' Slope= 0.0070 '/'
 Inlet Invert= 0.00', Outlet Invert= -1.26'

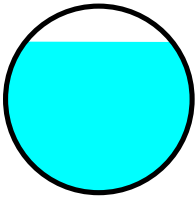

Reach 4R: Hanover - Downstream from Fleet

Hydrograph

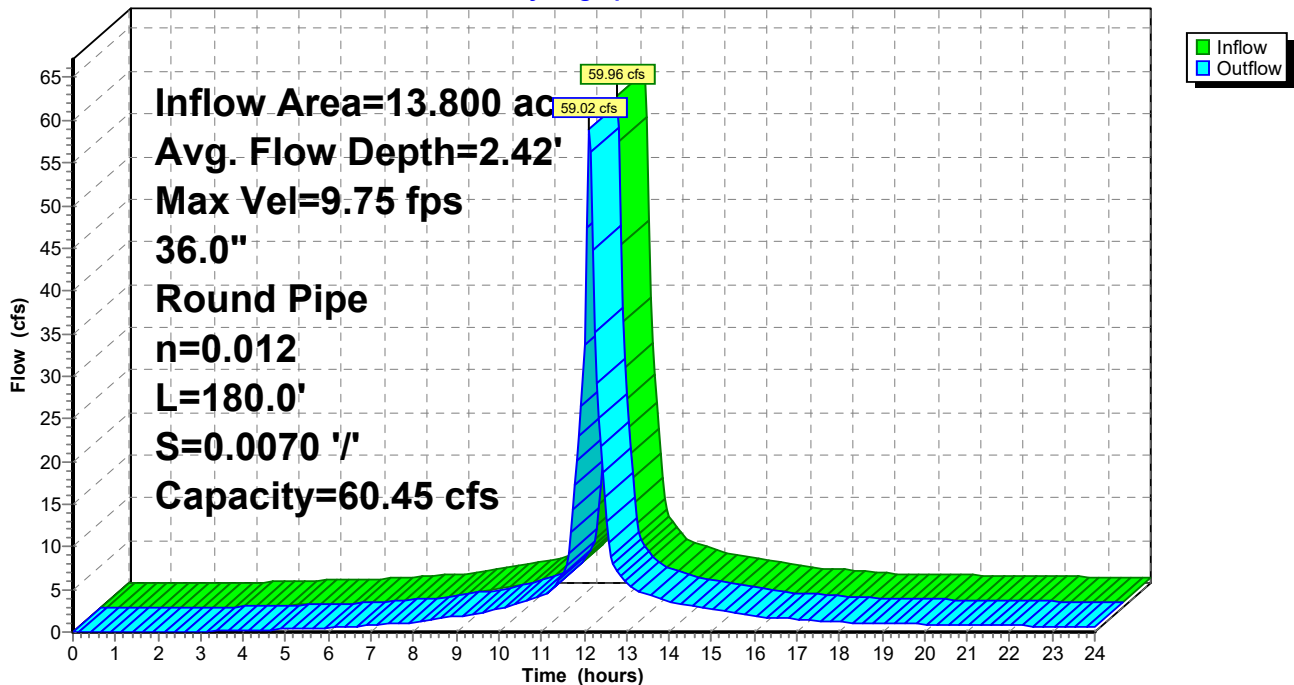

PROJECT CONDITIONS

Prepared by HP Inc.

HydroCAD® 10.00-26 s/n 10718 © 2020 HydroCAD Software Solutions LLC

Type III 24-hr Rainfall=5.00"

Printed 4/6/2023

Page 24

Summary for Reach 5R: Congress to Fleet

Inflow Area = 2.100 ac, Inflow Depth > 4.31"
 Inflow = 9.63 cfs @ 12.09 hrs, Volume= 0.753 af
 Outflow = 9.38 cfs @ 12.10 hrs, Volume= 0.753 af, Atten= 3%, Lag= 1.0 min

Routing by Stor-Ind+Trans method, Time Span= 0.00-24.00 hrs, dt= 0.05 hrs
 Max. Velocity= 6.23 fps, Min. Travel Time= 0.6 min
 Avg. Velocity = 2.27 fps, Avg. Travel Time= 1.6 min

Peak Storage= 339 cf @ 12.10 hrs
 Average Depth at Peak Storage= 1.22'
 Bank-Full Depth= 1.50' Flow Area= 1.8 sf, Capacity= 9.66 cfs

18.0" Round Pipe
 n= 0.010
 Length= 220.0' Slope= 0.0050 '/'
 Inlet Invert= 0.00', Outlet Invert= -1.10'

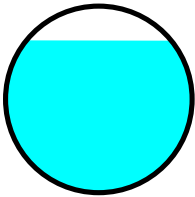

Reach 5R: Congress to Fleet

Hydrograph

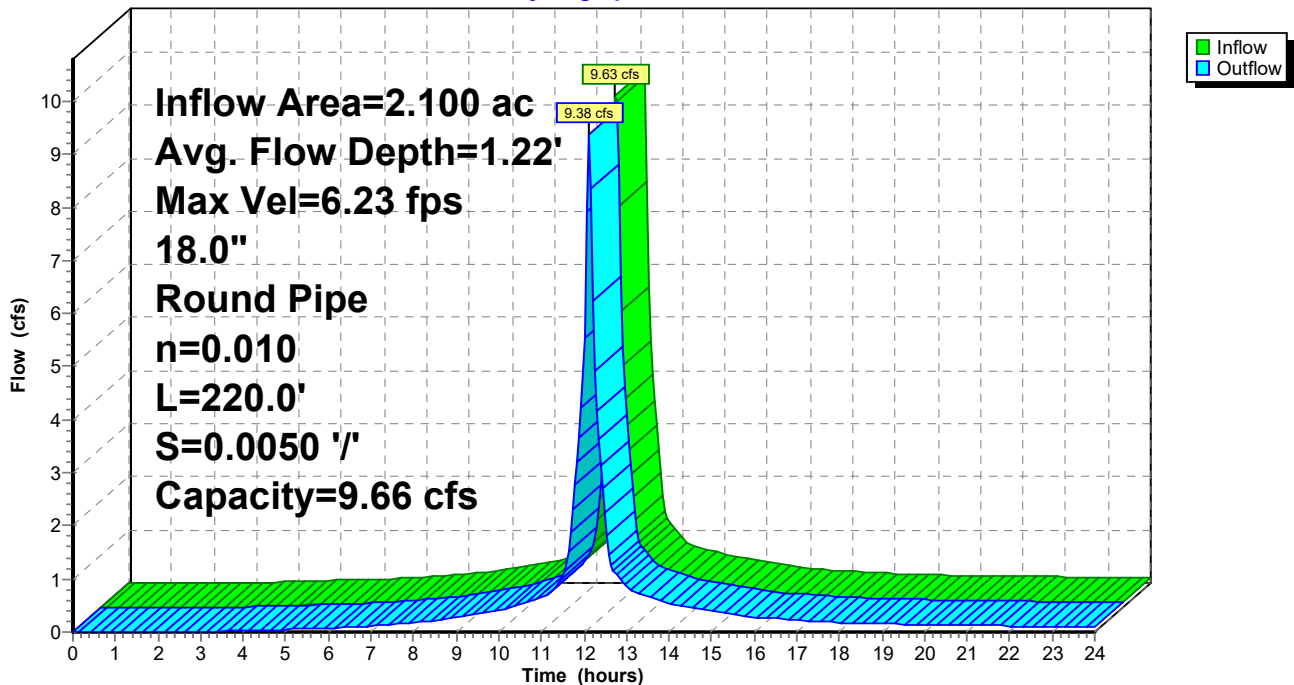

PROJECT CONDITIONS

Prepared by HP Inc.

HydroCAD® 10.00-26 s/n 10718 © 2020 HydroCAD Software Solutions LLC

Type III 24-hr Rainfall=5.00"

Printed 4/6/2023

Page 25

Summary for Reach 6R: Upper Vaughn Mall

Inflow Area = 1.100 ac, Inflow Depth > 4.31"
 Inflow = 5.05 cfs @ 12.09 hrs, Volume= 0.395 af
 Outflow = 4.93 cfs @ 12.10 hrs, Volume= 0.394 af, Atten= 2%, Lag= 1.0 min

Routing by Stor-Ind+Trans method, Time Span= 0.00-24.00 hrs, dt= 0.05 hrs
 Max. Velocity= 5.82 fps, Min. Travel Time= 0.6 min
 Avg. Velocity = 2.03 fps, Avg. Travel Time= 1.6 min

Peak Storage= 173 cf @ 12.10 hrs
 Average Depth at Peak Storage= 0.83'
 Bank-Full Depth= 1.25' Flow Area= 1.2 sf, Capacity= 6.46 cfs

15.0" Round Pipe
 n= 0.013
 Length= 200.0' Slope= 0.0100 '/'
 Inlet Invert= 0.00', Outlet Invert= -2.00'

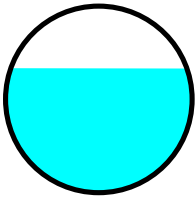

Reach 6R: Upper Vaughn Mall

Hydrograph

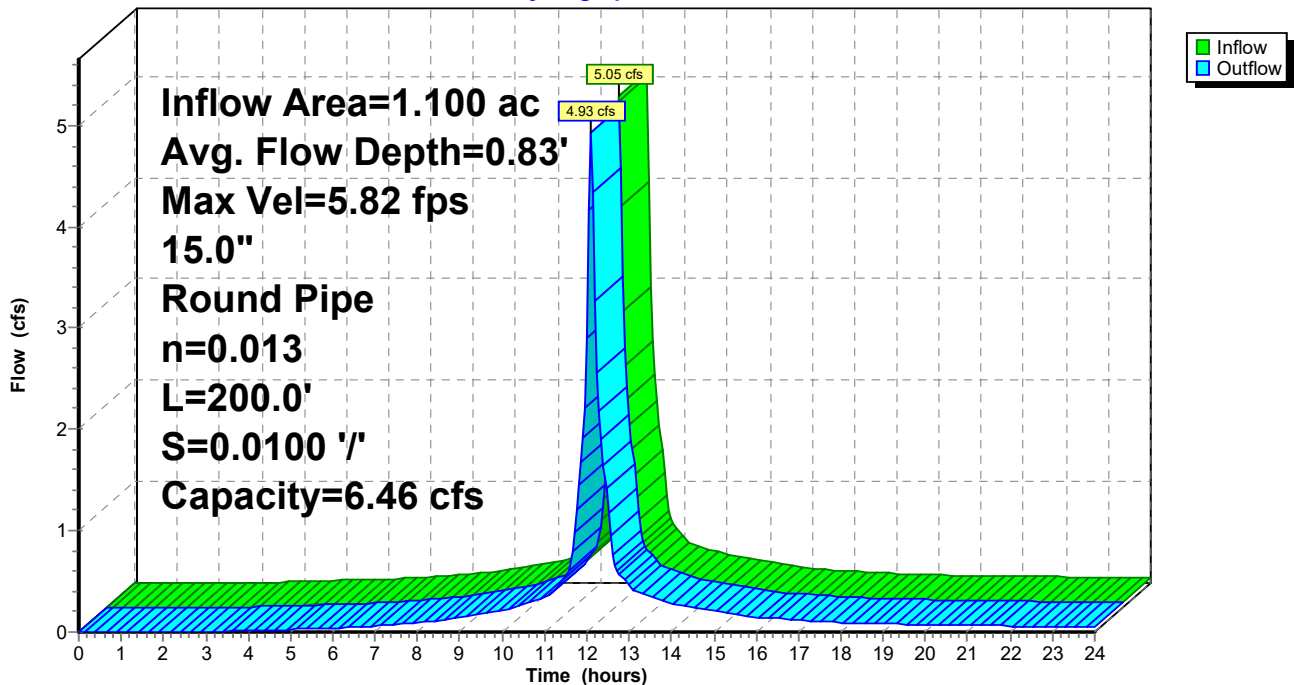

PROJECT CONDITIONS

Prepared by HP Inc.

HydroCAD® 10.00-26 s/n 10718 © 2020 HydroCAD Software Solutions LLC

Type III 24-hr Rainfall=5.00"

Printed 4/6/2023

Page 26

Summary for Reach 7R: Lower Vaughn Mall to Hanover

Inflow Area = 2.500 ac, Inflow Depth > 4.30"
 Inflow = 11.31 cfs @ 12.09 hrs, Volume= 0.897 af
 Outflow = 11.11 cfs @ 12.11 hrs, Volume= 0.896 af, Atten= 2%, Lag= 0.7 min

Routing by Stor-Ind+Trans method, Time Span= 0.00-24.00 hrs, dt= 0.05 hrs
 Max. Velocity= 5.93 fps, Min. Travel Time= 0.4 min
 Avg. Velocity = 2.04 fps, Avg. Travel Time= 1.2 min

Peak Storage= 286 cf @ 12.10 hrs
 Average Depth at Peak Storage= 1.17'
 Bank-Full Depth= 2.00' Flow Area= 3.1 sf, Capacity= 17.52 cfs

24.0" Round Pipe
 n= 0.013
 Length= 150.0' Slope= 0.0060 '/'
 Inlet Invert= 0.00', Outlet Invert= -0.90'

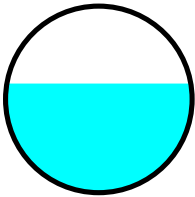

Reach 7R: Lower Vaughn Mall to Hanover

Hydrograph

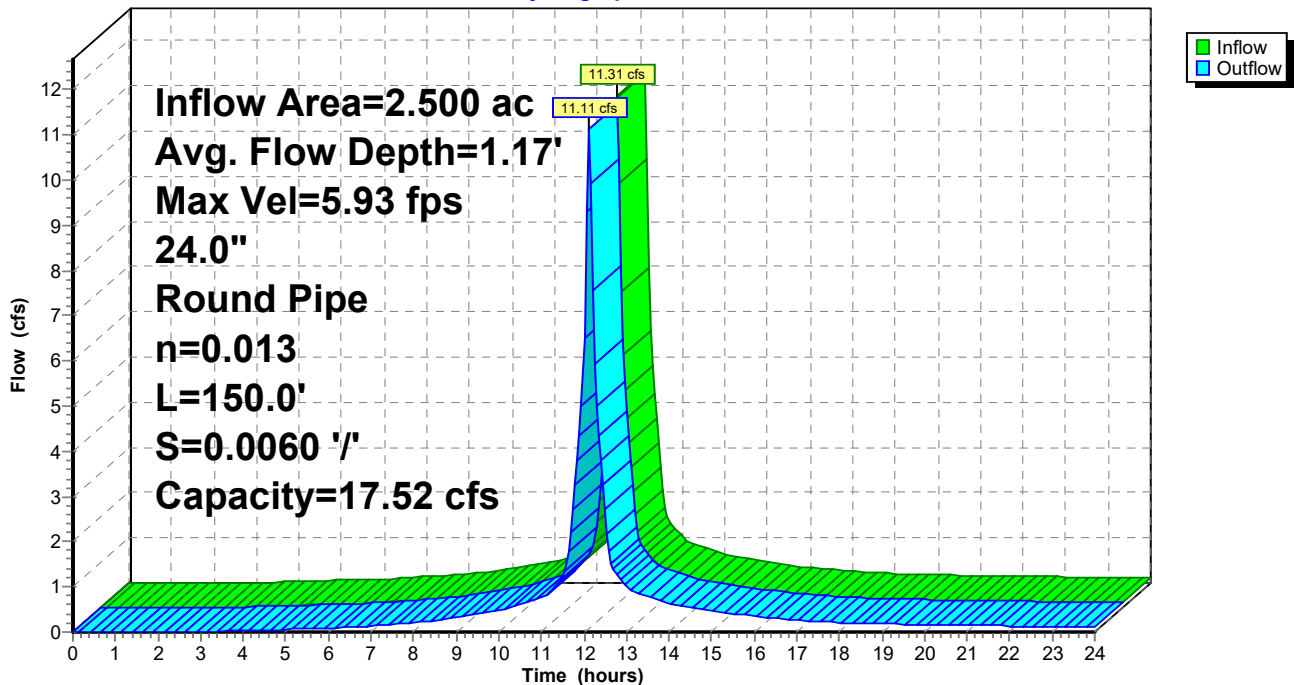

PROJECT CONDITIONS

Prepared by HP Inc.

HydroCAD® 10.00-26 s/n 10718 © 2020 HydroCAD Software Solutions LLC

Type III 24-hr Rainfall=5.00"

Printed 4/6/2023

Page 27

Summary for Reach 8R: Exist. 36" RCP, Downstream of V. Mall

Inflow Area = 17.500 ac, Inflow Depth > 4.30"
 Inflow = 75.20 cfs @ 12.11 hrs, Volume= 6.273 af
 Outflow = 74.07 cfs @ 12.12 hrs, Volume= 6.272 af, Atten= 2%, Lag= 0.6 min

Routing by Stor-Ind+Trans method, Time Span= 0.00-24.00 hrs, dt= 0.05 hrs
 Max. Velocity= 11.65 fps, Min. Travel Time= 0.3 min
 Avg. Velocity = 4.27 fps, Avg. Travel Time= 0.8 min

Peak Storage= 1,285 cf @ 12.12 hrs
 Average Depth at Peak Storage= 2.55'
 Bank-Full Depth= 3.00' Flow Area= 7.1 sf, Capacity= 72.26 cfs

36.0" Round Pipe
 n= 0.012
 Length= 200.0' Slope= 0.0100 '/'
 Inlet Invert= 0.00', Outlet Invert= -2.00'

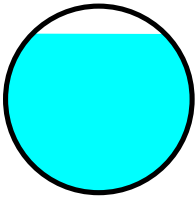

Reach 8R: Exist. 36" RCP, Downstream of V. Mall

Hydrograph

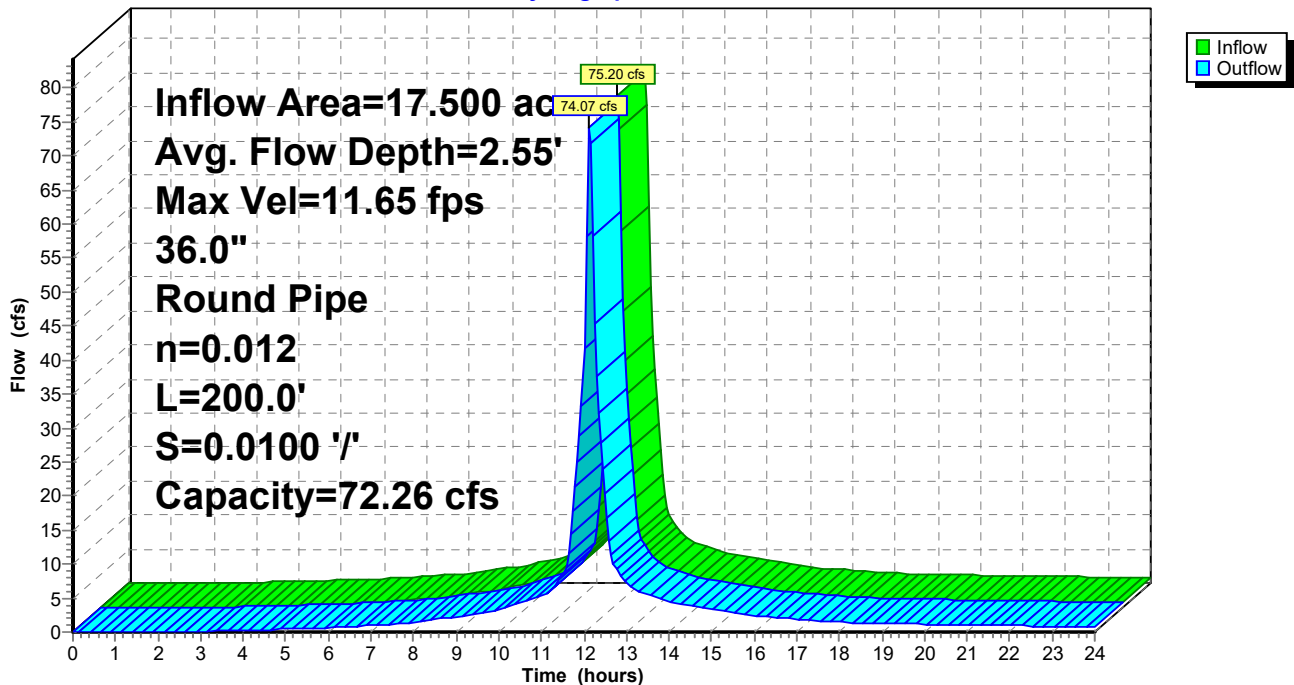

PROJECT CONDITIONS

Prepared by HP Inc.

HydroCAD® 10.00-26 s/n 10718 © 2020 HydroCAD Software Solutions LLC

Type III 24-hr Rainfall=5.00"

Printed 4/6/2023

Page 28

Summary for Reach 9AR: Maplewood Intercept

Inflow Area = 19.300 ac, Inflow Depth > 3.89"
Inflow = 65.53 cfs @ 12.12 hrs, Volume= 6.255 af
Outflow = 65.38 cfs @ 12.12 hrs, Volume= 6.255 af, Atten= 0%, Lag= 0.1 min

Routing by Stor-Ind+Trans method, Time Span= 0.00-24.00 hrs, dt= 0.05 hrs
Max. Velocity= 10.93 fps, Min. Travel Time= 0.0 min
Avg. Velocity = 4.18 fps, Avg. Travel Time= 0.1 min

Peak Storage= 185 cf @ 12.12 hrs
Average Depth at Peak Storage= 2.36'
Bank-Full Depth= 3.00' Flow Area= 7.1 sf, Capacity= 67.88 cfs

36.0" Round Pipe
n= 0.010
Length= 31.0' Slope= 0.0061 '/'
Inlet Invert= 0.00', Outlet Invert= -0.19'

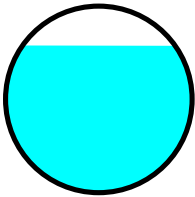

Reach 9AR: Maplewood Intercept

Hydrograph

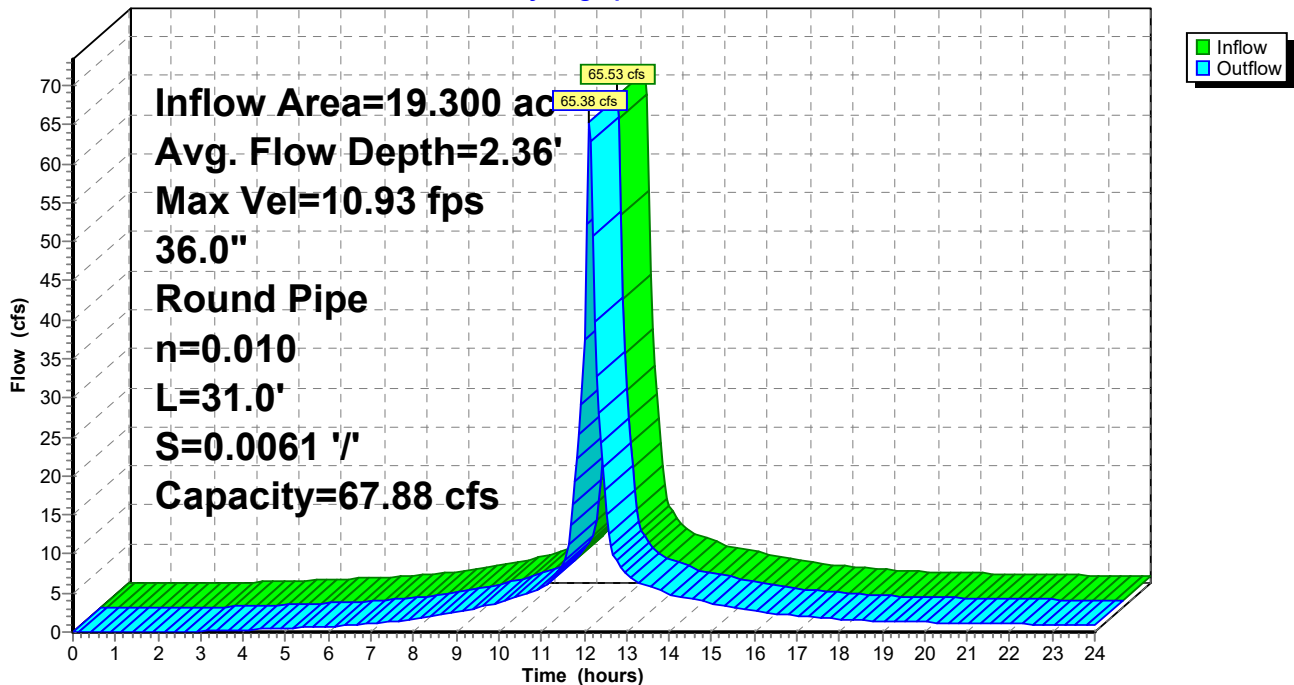

PROJECT CONDITIONS

Prepared by HP Inc.

HydroCAD® 10.00-26 s/n 10718 © 2020 HydroCAD Software Solutions LLC

Type III 24-hr Rainfall=5.00"

Printed 4/6/2023

Page 29

Summary for Reach 9BR: Maplewood Intercept

Inflow Area = 19.300 ac, Inflow Depth > 3.89"
Inflow = 65.38 cfs @ 12.12 hrs, Volume= 6.255 af
Outflow = 62.79 cfs @ 12.16 hrs, Volume= 6.249 af, Atten= 4%, Lag= 2.4 min

Routing by Stor-Ind+Trans method, Time Span= 0.00-24.00 hrs, dt= 0.05 hrs
Max. Velocity= 8.14 fps, Min. Travel Time= 1.2 min
Avg. Velocity = 3.10 fps, Avg. Travel Time= 3.2 min

Peak Storage= 4,740 cf @ 12.14 hrs
Average Depth at Peak Storage= 2.68'
Bank-Full Depth= 3.50' Flow Area= 9.6 sf, Capacity= 68.93 cfs

42.0" Round Pipe
n= 0.012
Length= 600.0' Slope= 0.0040 '/'
Inlet Invert= 0.00', Outlet Invert= -2.40'

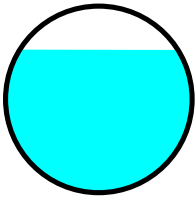

Reach 9BR: Maplewood Intercept

Hydrograph

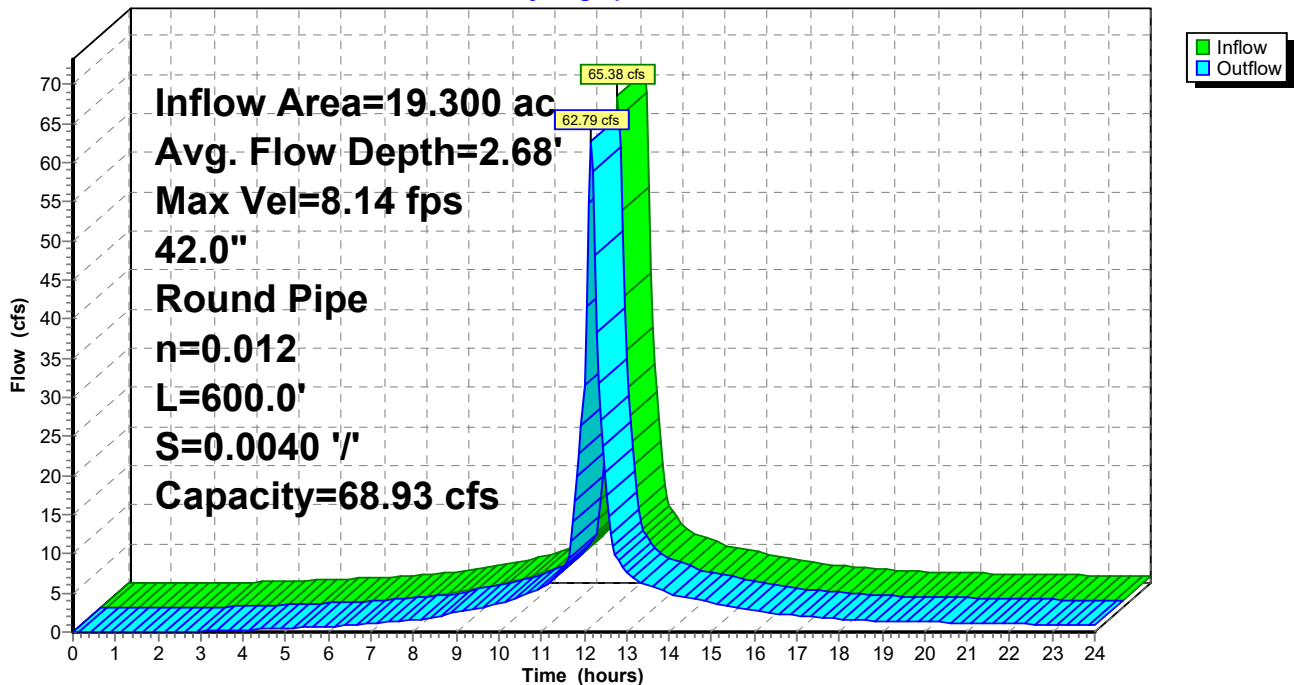

PROJECT CONDITIONS

Prepared by HP Inc.

HydroCAD® 10.00-26 s/n 10718 © 2020 HydroCAD Software Solutions LLC

Type III 24-hr Rainfall=5.00"

Printed 4/6/2023

Page 30

Summary for Reach 10R: Upper Bridge St.

Inflow Area = 6.700 ac, Inflow Depth > 4.91"
 Inflow = 41.55 cfs @ 12.12 hrs, Volume= 2.742 af
 Outflow = 40.88 cfs @ 12.14 hrs, Volume= 2.741 af, Atten= 2%, Lag= 0.9 min

Routing by Stor-Ind+Trans method, Time Span= 0.00-24.00 hrs, dt= 0.05 hrs
 Max. Velocity= 7.31 fps, Min. Travel Time= 0.4 min
 Avg. Velocity = 2.41 fps, Avg. Travel Time= 1.2 min

Peak Storage= 959 cf @ 12.13 hrs
 Average Depth at Peak Storage= 2.23'
 Bank-Full Depth= 3.00' Flow Area= 7.1 sf, Capacity= 45.70 cfs

36.0" Round Pipe
 n= 0.012
 Length= 170.0' Slope= 0.0040 '/'
 Inlet Invert= 0.00', Outlet Invert= -0.68'

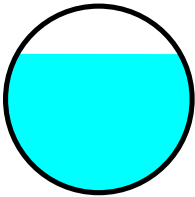

Reach 10R: Upper Bridge St.

Hydrograph

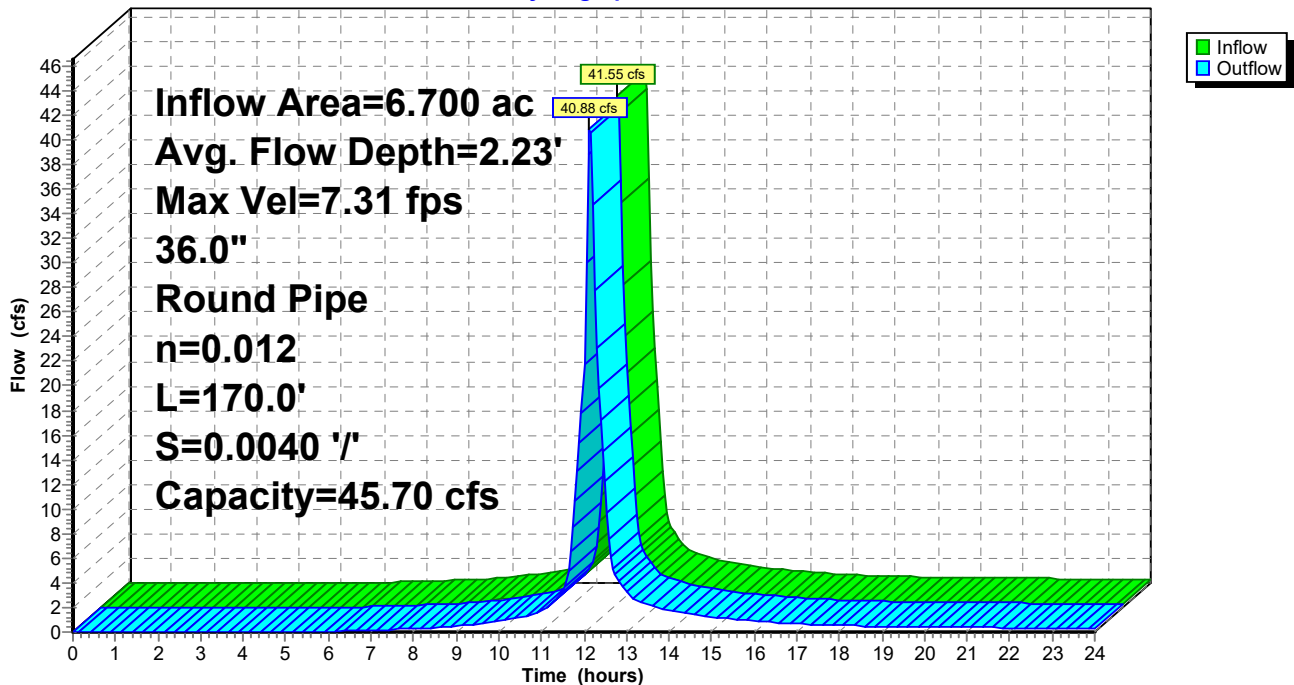

PROJECT CONDITIONS

Prepared by HP Inc.

HydroCAD® 10.00-26 s/n 10718 © 2020 HydroCAD Software Solutions LLC

Type III 24-hr Rainfall=5.00"

Printed 4/6/2023

Page 31

Summary for Reach 11R: Bridge Street Sag

Inflow Area = 11.200 ac, Inflow Depth > 4.58"
 Inflow = 59.33 cfs @ 12.12 hrs, Volume= 4.274 af
 Outflow = 58.29 cfs @ 12.13 hrs, Volume= 4.273 af, Atten= 2%, Lag= 0.7 min

Routing by Stor-Ind+Trans method, Time Span= 0.00-24.00 hrs, dt= 0.05 hrs
 Max. Velocity= 9.02 fps, Min. Travel Time= 0.3 min
 Avg. Velocity = 3.12 fps, Avg. Travel Time= 0.9 min

Peak Storage= 1,049 cf @ 12.12 hrs
 Average Depth at Peak Storage= 2.61'
 Bank-Full Depth= 3.00' Flow Area= 7.1 sf, Capacity= 55.97 cfs

36.0" Round Pipe
 n= 0.012
 Length= 160.0' Slope= 0.0060 '/'
 Inlet Invert= 0.00', Outlet Invert= -0.96'

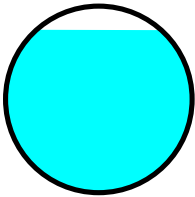

Reach 11R: Bridge Street Sag

Hydrograph

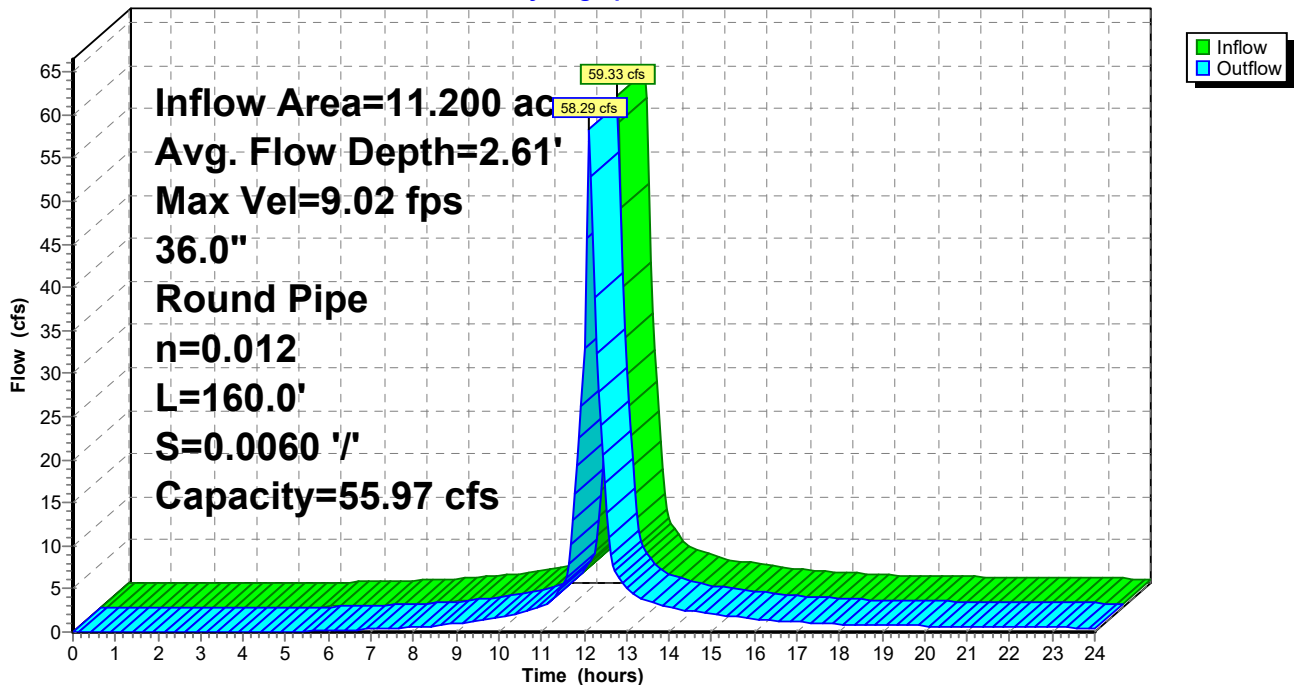

PROJECT CONDITIONS

Prepared by HP Inc.

HydroCAD® 10.00-26 s/n 10718 © 2020 HydroCAD Software Solutions LLC

Type III 24-hr Rainfall=5.00"

Printed 4/6/2023

Page 32

Summary for Reach 12CR: x-cntry intercept

Inflow Area = 22.300 ac, Inflow Depth > 3.80"
 Inflow = 72.44 cfs @ 12.15 hrs, Volume= 7.066 af
 Outflow = 71.03 cfs @ 12.17 hrs, Volume= 7.062 af, Atten= 2%, Lag= 1.1 min

Routing by Stor-Ind+Trans method, Time Span= 0.00-24.00 hrs, dt= 0.05 hrs
 Max. Velocity= 6.31 fps, Min. Travel Time= 0.6 min
 Avg. Velocity = 2.46 fps, Avg. Travel Time= 1.4 min

Peak Storage= 2,400 cf @ 12.16 hrs
 Average Depth at Peak Storage= 3.41'
 Bank-Full Depth= 4.00' Flow Area= 12.6 sf, Capacity= 69.59 cfs

48.0" Round Pipe
 n= 0.012
 Length= 210.0' Slope= 0.0020 '/'
 Inlet Invert= 0.00', Outlet Invert= -0.42'

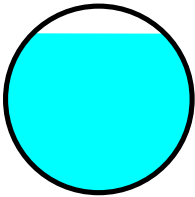

Reach 12CR: x-cntry intercept

Hydrograph

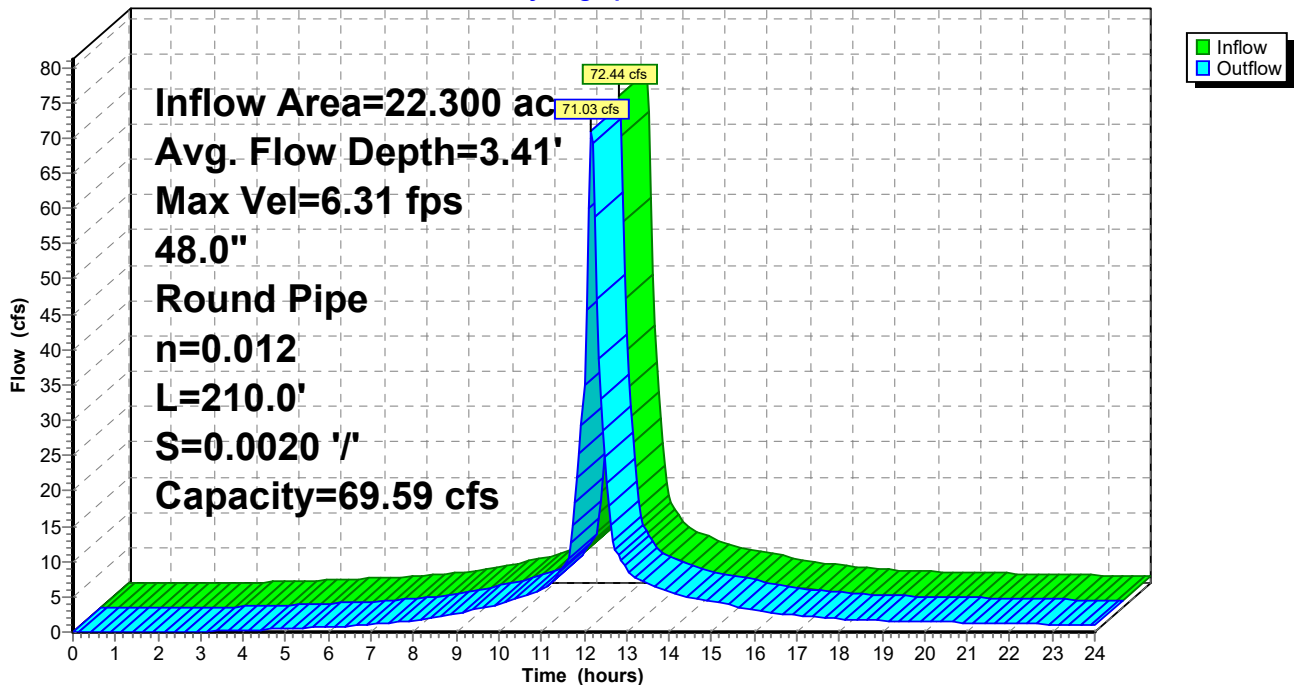

PROJECT CONDITIONS

Prepared by HP Inc.

HydroCAD® 10.00-26 s/n 10718 © 2020 HydroCAD Software Solutions LLC

Type III 24-hr Rainfall=5.00"

Printed 4/6/2023

Page 33

Summary for Reach 12R: Deer Street

Inflow Area = 14.700 ac, Inflow Depth > 4.41"
Inflow = 72.39 cfs @ 12.12 hrs, Volume= 5.399 af
Outflow = 70.96 cfs @ 12.13 hrs, Volume= 5.397 af, Atten= 2%, Lag= 1.0 min

Routing by Stor-Ind+Trans method, Time Span= 0.00-24.00 hrs, dt= 0.05 hrs
Max. Velocity= 6.31 fps, Min. Travel Time= 0.4 min
Avg. Velocity = 2.16 fps, Avg. Travel Time= 1.2 min

Peak Storage= 1,823 cf @ 12.12 hrs
Average Depth at Peak Storage= 3.39'
Bank-Full Depth= 4.00' Flow Area= 12.6 sf, Capacity= 69.59 cfs

48.0" Round Pipe
n= 0.012
Length= 160.0' Slope= 0.0020 '/'
Inlet Invert= 0.00', Outlet Invert= -0.32'

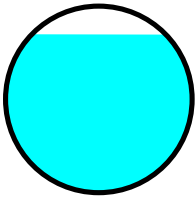

Reach 12R: Deer Street

Hydrograph

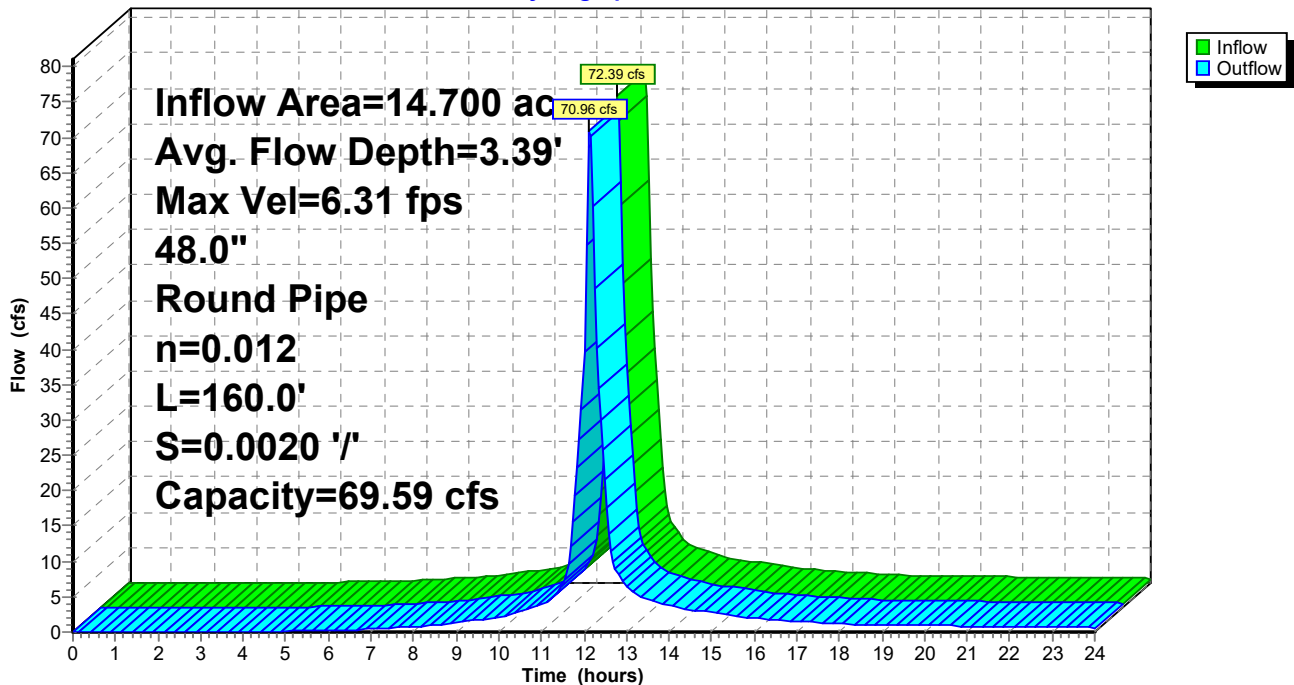

PROJECT CONDITIONS

Prepared by HP Inc.

HydroCAD® 10.00-26 s/n 10718 © 2020 HydroCAD Software Solutions LLC

Type III 24-hr Rainfall=5.00"

Printed 4/6/2023

Page 34

Summary for Pond 9: DMH #6 (Flow Splitter)

Inflow Area = 19.300 ac, Inflow Depth > 4.32"
 Inflow = 82.02 cfs @ 12.12 hrs, Volume= 6.951 af
 Outflow = 82.02 cfs @ 12.12 hrs, Volume= 6.951 af, Atten= 0%, Lag= 0.0 min
 Primary = 65.53 cfs @ 12.12 hrs, Volume= 6.255 af
 Secondary = 16.49 cfs @ 12.12 hrs, Volume= 0.696 af

Routing by Stor-Ind method, Time Span= 0.00-24.00 hrs, dt= 0.05 hrs
 Peak Elev= 9.69' @ 12.12 hrs

Device	Routing	Invert	Outlet Devices
#1	Primary	4.50'	36.0" Vert. Orifice/Grate C= 0.600
#2	Secondary	5.20'	18.0" Vert. Orifice/Grate C= 0.600

Primary OutFlow Max=63.94 cfs @ 12.12 hrs HW=9.53' (Free Discharge)

↳ **1=Orifice/Grate** (Orifice Controls 63.94 cfs @ 9.05 fps)

Secondary OutFlow Max=16.10 cfs @ 12.12 hrs HW=9.53' (Free Discharge)

↳ **2=Orifice/Grate** (Orifice Controls 16.10 cfs @ 9.11 fps)

Pond 9: DMH #6 (Flow Splitter)

Hydrograph

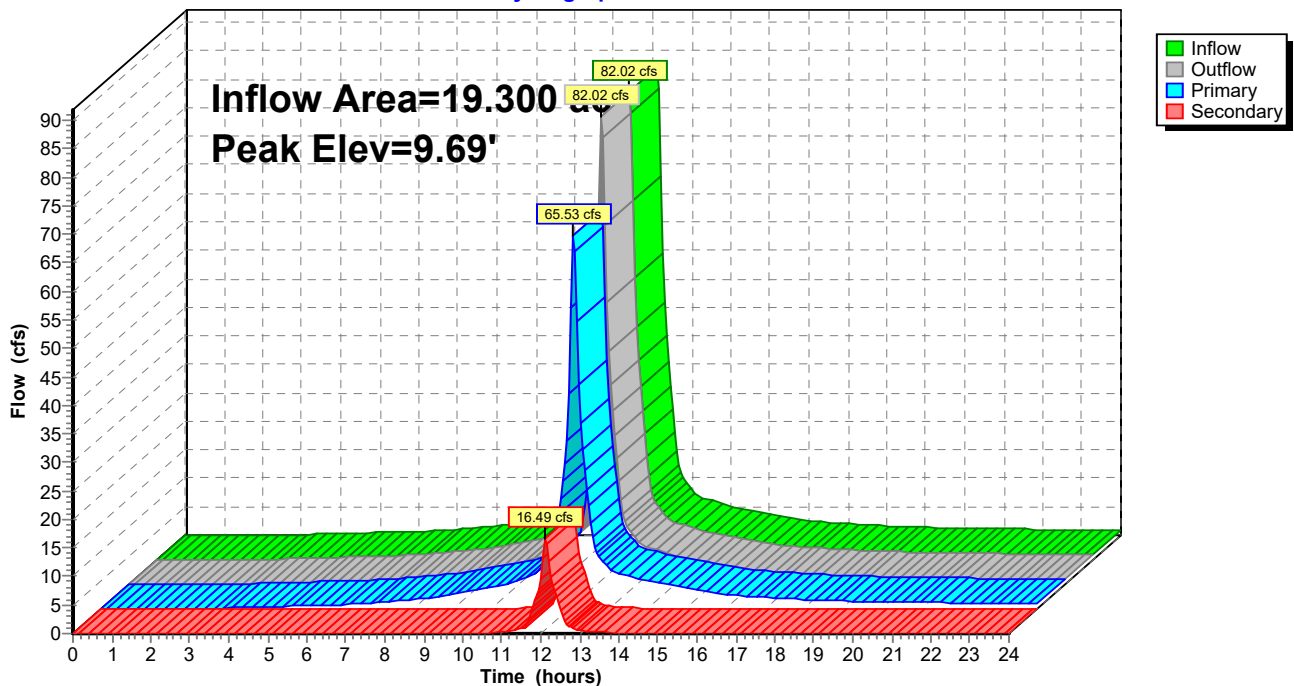

PROJECT CONDITIONS

Prepared by HP Inc.

HydroCAD® 10.00-26 s/n 10718 © 2020 HydroCAD Software Solutions LLC

Type III 24-hr Rainfall=5.00"

Printed 4/6/2023

Page 35

Summary for Pond 13: Twin 48" Outfall Pipes

Inflow Area = 37.000 ac, Inflow Depth > 4.04"
Inflow = 140.28 cfs @ 12.15 hrs, Volume= 12.459 af
Outflow = 140.28 cfs @ 12.15 hrs, Volume= 12.459 af, Atten= 0%, Lag= 0.0 min
Primary = 140.28 cfs @ 12.15 hrs, Volume= 12.459 af

Routing by Stor-Ind method, Time Span= 0.00-24.00 hrs, dt= 0.05 hrs
Peak Elev= 6.46' @ 12.15 hrs

Device	Routing	Invert	Outlet Devices
#1	Primary	-0.40'	48.0" Round New 48" X 2.00 L= 360.0' RCP, sq.cut end projecting, Ke= 0.500 Inlet / Outlet Invert= -0.40' / -1.12' S= 0.0020 '/ Cc= 0.900 n= 0.012, Flow Area= 12.57 sf

Primary OutFlow Max=140.08 cfs @ 12.15 hrs HW=6.46' TW=5.00' (Fixed TW Elev= 5.00')
↑1=New 48" (Outlet Controls 140.08 cfs @ 5.57 fps)

Pond 13: Twin 48" Outfall Pipes

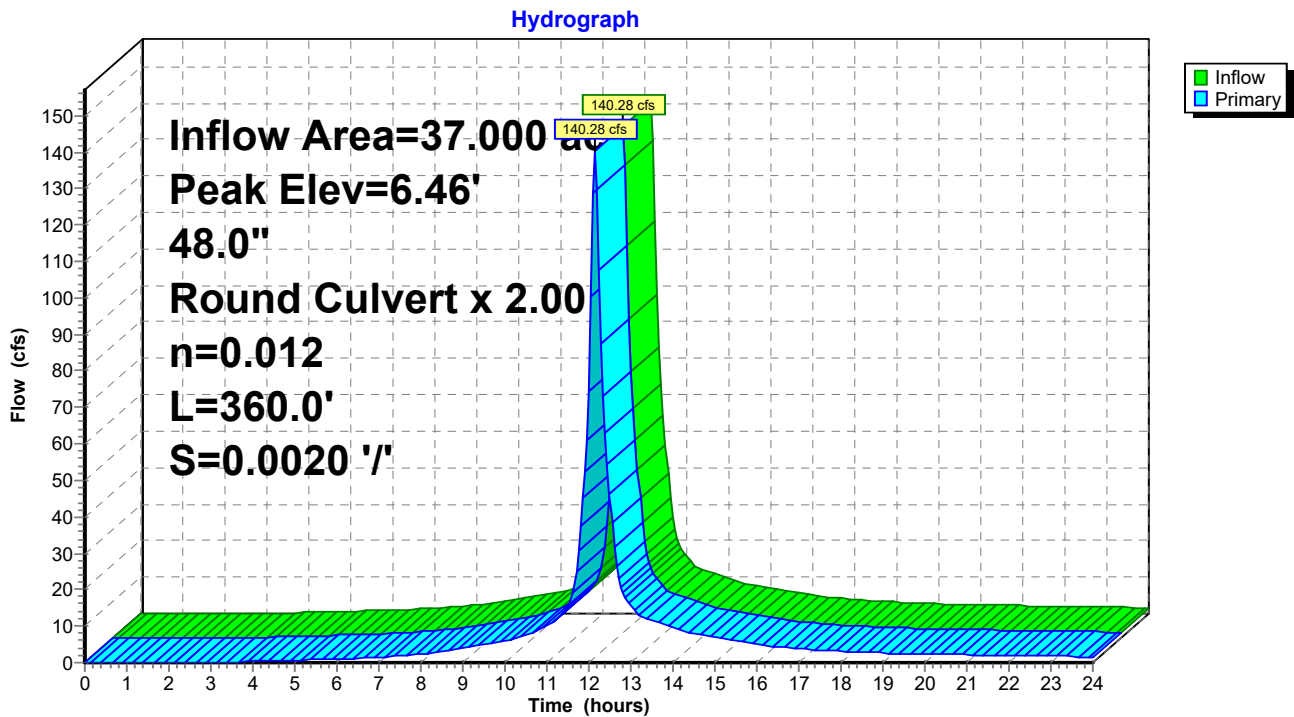



**US Army Corps
of Engineers**®
New England District

**Appendix B
New Hampshire General Permits
Required Information and USACE Section 404 Checklist**

USACE Section 404 Checklist

1. Attach any explanations to this checklist. Lack of information could delay a USACE permit determination.
2. All references to “work” include all work associated with the project construction and operation. Work includes filling, clearing, flooding, draining, excavation, dozing, stumping, etc.
3. See GC 3 for information on single and complete projects.
4. Contact USACE at (978) 318-8832 with any questions.
5. The information requested below is generally required in the NHDES Wetland Application. See page 61 for NHDES references and Admin Rules as they relate to the information below.

1. Impaired Waters	Yes	No
1.1 Will any work occur within 1 mile upstream in the watershed of an impaired water? See the following to determine if there is an impaired water in the vicinity of your work area. * https://nhdes-surface-water-quality-assessment-site-nhdes.hub.arcgis.com/ https://www.des.nh.gov/water/rivers-and-lakes/water-quality-assessment https://www4.des.state.nh.us/onestopdatamapper/onestopmapper.aspx	X	
2. Wetlands	Yes	No
2.1 Are there are streams, brooks, rivers, ponds, or lakes within 200 feet of any proposed work?	X	
2.2 Are there proposed impacts to tidal SAS, prime wetlands, or priority resource areas? Applicants may obtain information from the NH Department of Resources and Economic Development Natural Heritage Bureau (NHB) DataCheck Tool for information about resources located on the property at https://www4.des.state.nh.us/NHB-DataCheck/ .	X	
2.3 If wetland crossings are proposed, are they adequately designed to maintain hydrology, sediment transport & wildlife passage?	X	
2.4 Would the project remove part or all of a riparian buffer? (Riparian buffers are lands adjacent to streams where vegetation is strongly influenced by the presence of water. They are often thin lines of vegetation containing native grasses, flowers, shrubs and/or trees that line the stream banks. They are also called vegetated buffer zones.)	X	
2.5 The overall project site is more than 40 acres?		X
2.6 What is the area of the previously filled wetlands?	N/A	
2.7 What is the area of the proposed fill in wetlands?	3 SF	
2.8 What % of the overall project site will be previously and proposed filled wetlands?	N/A	
3. Wildlife	Yes	No
3.1 Has the NHB & USFWS determined that there are known occurrences of rare species, exemplary natural communities, Federal and State threatened and endangered species and habitat, in the vicinity of the proposed project? (All projects require an NHB ID number & a USFWS IPAC determination.) NHB DataCheck Tool: https://www4.des.state.nh.us/NHB-DataCheck/ . USFWS IPAC website: https://ipac.ecosphere.fws.gov/	X	

3.2 Would work occur in any area identified as either “Highest Ranked Habitat in N.H.” or “Highest Ranked Habitat in Ecological Region”? (These areas are colored magenta and green, respectively, on NH Fish and Game’s map, “2010 Highest Ranked Wildlife Habitat by Ecological Condition.”) Map information can be found at: <ul style="list-style-type: none"> • PDF: https://wildlife.state.nh.us/wildlife/wap-high-rank.html. • Data Mapper: www.granit.unh.edu. • GIS: www.granit.unh.edu/data/downloadfreedata/category/databycategory.html. 		X
3.3 Would the project impact more than 20 acres of an undeveloped land block (upland, wetland/waterway) on the entire project site and/or on an adjoining property(s)?		X
3.4 Does the project propose more than a 10-lot residential subdivision, or a commercial or industrial development?		X
3.5 Are stream crossings designed in accordance with the GC 31?	X	
4. Flooding/Floodplain Values	Yes	No
4.1 Is the proposed project within the 100-year floodplain of an adjacent river or stream?	X	
4.2 If 4.1 is yes, will compensatory flood storage be provided if the project results in a loss of flood storage?		X
5. Historic/Archaeological Resources		
For a minimum, minor or major impact project - a copy of the RPR Form (www.nh.gov/nhdhr/review) with your DES file number shall be sent to the NH Division of Historical Resources as required on Page 37 GC 14(d) of the GP document**	X	
6. Minimal Impact Determination (for projects that exceed 1 acre of permanent impact)	Yes	No
Projects with greater than 1 acre of permanent impact must include the following: <ul style="list-style-type: none"> • Functional assessment for aquatic resources in the project area. • On and off-site alternative analysis. • Provide additional information and description for how the below criteria are met. 		
6.1 Will there be complete loss of aquatic resources on site?		
6.2 Have the impacts to the aquatic resources been avoided and minimized to the greatest extent practicable?		
6.3 Will all aquatic resource function be lost?		
6.4 Does the aquatic resource (s) have regional significance (watershed or ecoregion)?		
6.5 Is there an on-site alternative with less impact?		
6.6 Is there an off-site alternative with less impact?		
6.7 Will there be a loss to a resource dependent species?		
6.8 Are indirect impacts greater than 1 acre within and adjacent to the project area?		
6.9 Does the proposed mitigation replace aquatic resource function for direct, indirect, and cumulative impacts?		

*Although this checklist utilizes state information, its submittal to USACE is a federal requirement.

** If your project is not within Federal jurisdiction, coordination with NH DHR is not required under Federal law.

U.S. Army Corps of Engineers
New Hampshire Programmatic General Permit (PGP)
Appendix B USACE Section 404 Checklist
Repair of the Maplewood Avenue Bridge over North Mill Pond, Portsmouth, NH Explanations for Checklist Answers

- 1.1 North Mill Pond is marginally impaired for fish & shellfish consumption due to mercury, PCBs and dioxins according to the 2020 303(d) list. The proposed project will not add to these impairments.
- 2.1 & 2.2 The project purpose is to repair a deteriorating stream crossing located over coastal waters of the State of NH. The City of Portsmouth is proposing to rehabilitate the grouted corrugated metal plate arch (CMPA) liner that was installed in 1976 as part of previous rehabilitation project. The Maplewood Avenue bridge is a heavily trafficked vital piece of infrastructure within the City as it acts as gateway to the downtown area. The proposed repair project includes installation of a spray-applied geopolymer liner to the inside surface of the metal culvert liner to restore structural integrity. North Mill Pond will be affected by the project.
- 2.4 Riparian buffers will be temporarily affected by the project as required in order to repair the deteriorating culvert liner and for re-installation of riprap; however, these impacts have been minimized to the extent practicable. Temporary impact areas will be restored upon completion of construction.
- 3.1 The NH Natural Heritage Bureau was contacted regarding the proposed project (see attached letter NHB23- 1686, dated 6/1/2023). The database check resulted in a finding of no recorded occurrences for sensitive species near this project area.

During a pre-application/mitigation meeting a request was made to consult with New Hampshire Fish and Game (NHFG) with respect to potential impacts to Atlantic or shortnose sturgeon as a result of the project. In an email received June 9, 2023 NHFG commented “we do not expect impacts to Atlantic or shortnose sturgeon as a result of this project”. Additionally, a request was made to have some conditions be incorporated into the permit. These conditions have been noted on the plans on Sheet 8 of 20. A copy of the email from NHF&G is included with this permit application.

An official Federally-listed species list was obtained from the US Fish and Wildlife Service (USFWS) using the Information for Planning and Conservation (IPAC) online tool on June 09, 2023 (Project Code: 2023-0010149). The list includes the Federally-threatened Northern Long Eared Bat (*Myotis septentrionalis*; NLEB) and Roseate Tern (*Sterna dougallii dougallii*).

Tree removal is limited to (6) - 10" DBH trees and (5) - 8" DBH trees that will be removed outside of the USFWS time of year restriction for NLEB. The project was reviewed for potential effects to NLEB using the key within the IPAC system. Per the attached documentation, Project Code 2023-0010149, the proposed action is not likely to result in unauthorized take of the northern long-eared bat.

The project was reviewed for potential effects to Roseate Tern using the key within the IPAC system. Per the Verification Letter issued for the project, the proposed action received a determination of “No Effect” based on responses to the USFWS Northeast DKey.

The ESA consultation status is incomplete, and no project activities should occur until consultation between the Service and the Federal action agency (USACE), is completed. This consultation will be completed during USACE’s review of the application and prior to issuance of the USACE GP for

the project.

Copies of the species list and documentation are included with this permit application.

- 4.1 The proposed repair project is located within the 100-year floodplain of North Mill Pond but will not result in a loss of flood storage. The proposed project includes the repair of a crossing by installing a spray-applied geopolymer liner to the inside surface of the metal culvert liner to restore structural integrity and re-installing riprap where it once was installed. In order to offset the decrease in hydraulic area resulting from the geopolymer liner, portions of the concrete footings will be removed. Refer to the attached report of supporting Information for more details.
.

5. A Request for Project Review was submitted in August 2022 to the New Hampshire Division of Historic Resources (NHDHR). A response was received stating “No Historic Properties Affected”. At the time of the review only the slip lining of the culvert was proposed. Since that time the City has identified additional repairs that are necessary to stabilize the crossing and protect the traveling public until a full replacement can be planned for. A supplemental RPR was submitted to NHDHR for review on June 12, 2023. A response was received from NHDHR with a determination of “No Historic Properties Affected” for the additional work that is being proposed. Copies of both responses are included in this permit application.

**Natural Heritage Bureau (NHB) Review &
NHFG Coordination**

New Hampshire Natural Heritage Bureau NHB DataCheck Results Letter

To: Hoyle, Tanner & Associates / Deb Coon
Hoyle, Tanner & Associates, Inc.
150 Dow Street
Manchester, NH 03101

From: NH Natural Heritage Bureau

Date: 6/1/2023 (This letter is valid through 6/1/2024)

Re: Review by NH Natural Heritage Bureau of request dated 6/1/2023

Permit Type: Wetland Standard Dredge & Fill - Major

NHB ID: NHB23-1686

Applicant: Hoyle, Tanner & Associates / Deb Coon

Location: Portsmouth
Tax Map: 123 & 124, Tax Lot: N/A
Address: Maplewood Ave

Proj. Description: The project is to repair the grouted corrugated metal plate arch (CMPA) liner that was installed in 1976 as part of previous rehabilitation project- the repair will consist of installation of a spray-applied geopolymer liner to the inside surface of the metal culvert liner to restore structural integrity. In addition, sections of the retaining wall supporting Maplewood Avenue will be reconstructed or stabilized with reuse of the existing stone. Supplemental riprap will be reinstalled along areas of the north side inlet to protect the restored retaining walls from future tidal impacts. Drainage system improvements, roadway reconstruction, and rail support slab replacement will mitigate the existing roadway settlement, ponding, and sidewalk rotation. This Request replaces expired NHB22-1712

The NH Natural Heritage database has been checked for records of rare species and exemplary natural communities near the area mapped below. The species considered include those listed as Threatened or Endangered by either the state of New Hampshire or the federal government. We currently have no recorded occurrences for sensitive species near this project area.

A negative result (no record in our database) does not mean that a sensitive species is not present. Our data can only tell you of known occurrences, based on information gathered by qualified biologists and reported to our office. However, many areas have never been surveyed, or have only been surveyed for certain species. An on-site survey would provide better information on what species and communities are indeed present.

Based on the information submitted, no further consultation with the NH Fish and Game Department pursuant to Fis 1004 is required.

New Hampshire Natural Heritage Bureau
NHB DataCheck Results Letter

MAP OF PROJECT BOUNDARIES FOR: NHB23-1686



Coon, Deb L.

From: Snyder, Kimberly <Kimberly.C.Snyder@wildlife.nh.gov>
Sent: Friday, June 9, 2023 9:12 AM
To: Peace, Kimberly R.
Cc: FGC: NHFG review; Coon, Deb L.; Winters, Melissa
Subject: [External] FW: Mitigation Pre-App Meeting; Maplewood Ave, Portsmouth
Attachments: DataCheckResults-Letter_NHB22-1712.pdf

Kimberly,

Please see Melissa Winter's response from 3/13/23 below. NHFG considered this our response and comments on this project. We do not expect impacts to Atlantic or shortnose sturgeon as a result of this project.

Kim S.
Program Planner
Nongame and Endangered Wildlife Program
New Hampshire Fish and Game Department
Kimberly.C.Snyder@wildlife.nh.gov
Phone: 603-271-0467

From: Winters, Melissa <Melissa.J.Winters@wildlife.nh.gov>
Sent: Monday, March 13, 2023 9:04 AM
To: Richos, Sarah <Sarah.B.Richos@des.nh.gov>; Peace, Kimberly R. <kpeace@hoyletanner.com>; Lachance, Aaron M. <alachance@hoyletanner.com>; Coon, Deb L. <dcoon@hoyletanner.com>; Dave Desfosses <djdesfosses@cityofportsmouth.com>; Daniel Rochette <drochette@underwoodengineers.com>; Phil MacDonald <pmac@underwoodengineers.com>; Price, David <DAVID.A.PRICE@des.nh.gov>; Duclos, Kristin <Kristin.L.Duclos@des.nh.gov>; Tilton, Mary Ann <mary.a.tilton@des.nh.gov>; Fioravante, Kendall <Kendall.L.Fioravante@des.nh.gov>; DNCR: NHB Review <nhbreview@dncr.nh.gov>; Brochi.Jean@epa.gov; 'Lefebvre, Lindsey E CIV USARMY CENAE (US)' <Lindsey.E.Lefebvre@usace.army.mil>; Litwinenko, Ashley <Ashley.M.Litwinenko@dncr.nh.gov>; Severance, Madeline <Madeline.P.Severance@dncr.nh.gov>
Cc: FGC: NHFG review <NHFGreview@wildlife.nh.gov>
Subject: RE: Mitigation Pre-App Meeting; Maplewood Ave, Portsmouth

Morning,
NHFG will not be attending this meeting. Please reach out if wildlife/habitat concerns or questions are raised during the meeting or through project planning.

In general, we request the following be included as conditions to permits regardless if there are known occurrences at this time of rare wildlife species.

1. All manufactured erosion and sediment control products, with the exception of turf reinforcement mats, utilized for, but not limited to, slope protection, runoff diversion, slope interruption, perimeter control, inlet protection, check dams, and sediment traps shall not contain plastic, or multifilament or monofilament polypropylene netting or mesh with an opening size of greater than 1/8 inches.
2. All observations of threatened or endangered species on the project site shall be reported immediately to the NHFG nongame and endangered wildlife environmental review program by phone at 603-271-2461 and by email at NHFGreview@wildlife.nh.gov, with the email subject line containing the NHB DataCheck tool results letter assigned number, the project name, and the term Wildlife Species Observation.

3. Photographs of the observed species and nearby elements of habitat or areas of land disturbance shall be provided to NHFG in digital format at the above email address for verification, as feasible.
4. In the event a threatened or endangered species is observed on the project site during the term of the permit, the species shall not be disturbed, handled, or harmed in any way prior to consultation with NHFG and implementation of corrective actions recommended by NHFG.
5. NHFG, including its employees and authorized agents, shall have access to the property during the term of the permit.

Thank you,
Melissa

-----Original Appointment-----

From: Richos, Sarah <Sarah.B.Richos@des.nh.gov>

Sent: Wednesday, March 8, 2023 11:28 AM

To: Peace, Kimberly R.; Lachance, Aaron M.; Coon, Deb L.; Dave Desfosses; Daniel Rochette; Phil MacDonald; Price, David; Duclos, Kristin; Tilton, Mary Ann; Fioravante, Kendall; DNCR: NHB Review; Brochi.Jean@epa.gov; 'Lefebvre, Lindsey E CIV USARMY CENAE (US)'; Winters, Melissa; Litwinenko, Ashley; Severance, Madeline

Subject: Mitigation Pre-App Meeting; Maplewood Ave, Portsmouth

When: Thursday, March 16, 2023 10:30 AM-11:30 AM (UTC-05:00) Eastern Time (US & Canada).

Where: Microsoft Teams Meeting

Improvement to existing outfall capacity (Alternatives Considered): Construct new 48" RCP pipe parallel to existing outfall (proposed) Remove and replace existing outfall with a bigger pipe in same location/footprint (Constructability and cost issues, not proposed) Replace existing headwall Stormwater Treatment Unit-jellyfish filter Maplewood Avenue Bridge Repair Project: Adjacent project being completed by the City on a similar permitting and construction timeline. Some of the permitting efforts completed / to be completed for the Maplewood Avenue Bridge project overlap with the CSO project and therefore it is helpful to discuss them concurrently with NHDES at this time. All discussion in this meeting pertains to the CSO project unless specifically noted otherwise.

Microsoft Teams meeting

Join on your computer, mobile app or room device

[Click here to join the meeting](#)

Meeting ID: 228 032 888 422

Passcode: FsqBPz

[Download Teams](#) | [Join on the web](#)

Join with a video conferencing device

nhgov@m.webex.com

Video Conference ID: 112 801 020 6

[Alternate VTC instructions](#)

Or call in (audio only)

[+1 603-931-4944,,492667667#](#) United States, Concord

Phone Conference ID: 492 667 667#

[Find a local number](#) | [Reset PIN](#)

[Learn More](#) | [Meeting options](#)

CAUTION: This email originated from outside of the organization. Do not click links or open attachments unless you recognize the sender and know the content is safe.

US Fish and Wildlife (USF&W) IPaC Results & Documentation



United States Department of the Interior



FISH AND WILDLIFE SERVICE
New England Ecological Services Field Office
70 Commercial Street, Suite 300
Concord, NH 03301-5094
Phone: (603) 223-2541 Fax: (603) 223-0104

In Reply Refer To:

June 09, 2023

Project Code: 2023-0010149

Project Name: Repairs to the Maplewood Avenue Bridge over North Mill Pond, Portsmouth, NH

Subject: List of threatened and endangered species that may occur in your proposed project location or may be affected by your proposed project

To Whom It May Concern:

Updated 4/12/2023 - Please review this letter each time you request an Official Species List, we will continue to update it with additional information and links to websites may change.

About Official Species Lists

The purpose of the Act is to provide a means whereby threatened and endangered species and the ecosystems upon which they depend may be conserved. Federal and non-Federal project proponents have responsibilities under the Act to consider effects on listed species.

The enclosed species list identifies threatened, endangered, proposed, and candidate species, as well as proposed and final designated critical habitat, that may occur within the boundary of your proposed project and/or may be affected by your proposed project. The species list fulfills the requirements of the U.S. Fish and Wildlife Service (Service) under section 7(c) of the Endangered Species Act (Act) of 1973, as amended (16 U.S.C. 1531 et seq.).

New information based on updated surveys, changes in the abundance and distribution of species, changed habitat conditions, or other factors could change this list. Please note that under 50 CFR 402.12(e) of the regulations implementing section 7 of the Act, the accuracy of this species list should be verified after 90 days. The Service recommends that verification be completed by visiting the ECOS-IPaC website at regular intervals during project planning and implementation for updates to species lists and information. An updated list may be requested by returning to an existing project's page in IPaC.

Endangered Species Act Project Review

Please visit the “**New England Field Office Endangered Species Project Review and Consultation**” website for step-by-step instructions on how to consider effects on listed

species and prepare and submit a project review package if necessary:

<https://www.fws.gov/office/new-england-ecological-services/endangered-species-project-review>

NOTE Please do not use the **Consultation Package Builder** tool in IPaC except in specific situations following coordination with our office. Please follow the project review guidance on our website instead and reference your **Project Code** in all correspondence.

Northern Long-eared Bat - (Updated 4/12/2023) The Service published a final rule to reclassify the northern long-eared bat (NLEB) as endangered on November 30, 2022. The final rule went into effect on March 31, 2023. You may utilize the **Northern Long-eared Bat Rangewide Determination Key** available in IPaC. More information about this Determination Key and the Interim Consultation Framework are available on the northern long-eared bat species page:

<https://www.fws.gov/species/northern-long-eared-bat-myotis-septentrionalis>

For projects that previously utilized the 4(d) Determination Key, the change in the species' status may trigger the need to re-initiate consultation for any actions that are not completed and for which the Federal action agency retains discretion once the new listing determination becomes effective. If your project was not completed by March 31, 2023, and may result in incidental take of NLEB, please reach out to our office at newengland@fws.gov to see if reinitiation is necessary.

Additional Info About Section 7 of the Act

Under section 7(a)(2) of the Act and its implementing regulations (50 CFR 402 et seq.), Federal agencies are required to determine whether projects may affect threatened and endangered species and/or designated critical habitat. If a Federal agency, or its non-Federal representative, determines that listed species and/or designated critical habitat may be affected by the proposed project, the agency is required to consult with the Service pursuant to 50 CFR 402. In addition, the Federal agency also may need to consider proposed species and proposed critical habitat in the consultation. 50 CFR 402.14(c)(1) specifies the information required for consultation under the Act regardless of the format of the evaluation. More information on the regulations and procedures for section 7 consultation, including the role of permit or license applicants, can be found in the "Endangered Species Consultation Handbook" at:

<https://www.fws.gov/service/section-7-consultations>

In addition to consultation requirements under Section 7(a)(2) of the ESA, please note that under sections 7(a)(1) of the Act and its implementing regulations (50 CFR 402 et seq.), Federal agencies are required to utilize their authorities to carry out programs for the conservation of threatened and endangered species. Please contact NEFO if you would like more information.

Candidate species that appear on the enclosed species list have no current protections under the ESA. The species' occurrence on an official species list does not convey a requirement to

consider impacts to this species as you would a proposed, threatened, or endangered species. The ESA does not provide for interagency consultations on candidate species under section 7, however, the Service recommends that all project proponents incorporate measures into projects to benefit candidate species and their habitats wherever possible.

Migratory Birds

In addition to responsibilities to protect threatened and endangered species under the Endangered Species Act (ESA), there are additional responsibilities under the Migratory Bird Treaty Act (MBTA) and the Bald and Golden Eagle Protection Act (BGEPA) to protect native birds from project-related impacts. Any activity, intentional or unintentional, resulting in take of migratory birds, including eagles, is prohibited unless otherwise permitted by the U.S. Fish and Wildlife Service (50 C.F.R. Sec. 10.12 and 16 U.S.C. Sec. 668(a)). For more information regarding these Acts see:

<https://www.fws.gov/program/migratory-bird-permit>

<https://www.fws.gov/library/collections/bald-and-golden-eagle-management>

Please feel free to contact us at **newengland@fws.gov** with your **Project Code** in the subject line if you need more information or assistance regarding the potential impacts to federally proposed, listed, and candidate species and federally designated and proposed critical habitat.

Attachment(s): Official Species List

Attachment(s):

- Official Species List
-

OFFICIAL SPECIES LIST

This list is provided pursuant to Section 7 of the Endangered Species Act, and fulfills the requirement for Federal agencies to "request of the Secretary of the Interior information whether any species which is listed or proposed to be listed may be present in the area of a proposed action".

This species list is provided by:

New England Ecological Services Field Office

70 Commercial Street, Suite 300

Concord, NH 03301-5094

(603) 223-2541

PROJECT SUMMARY

Project Code: 2023-0010149

Project Name: Repairs to the Maplewood Avenue Bridge over North Mill Pond, Portsmouth, NH

Project Type: Bridge - Maintenance

Project Description: Repairs to the Maplewood Avenue Bridge over North Mill Pond, Portsmouth, NH

Project Location:

The approximate location of the project can be viewed in Google Maps: <https://www.google.com/maps/@43.0797049,-70.76530674241938,14z>

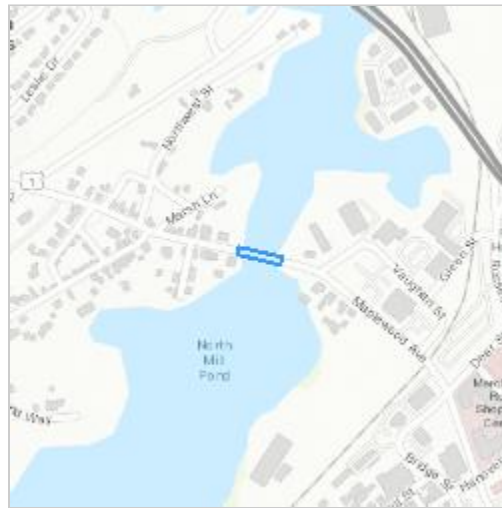

Counties: Rockingham County, New Hampshire

ENDANGERED SPECIES ACT SPECIES

There is a total of 2 threatened, endangered, or candidate species on this species list.

Species on this list should be considered in an effects analysis for your project and could include species that exist in another geographic area. For example, certain fish may appear on the species list because a project could affect downstream species.

IPaC does not display listed species or critical habitats under the sole jurisdiction of NOAA Fisheries¹, as USFWS does not have the authority to speak on behalf of NOAA and the Department of Commerce.

See the "Critical habitats" section below for those critical habitats that lie wholly or partially within your project area under this office's jurisdiction. Please contact the designated FWS office if you have questions.

-
1. [NOAA Fisheries](#), also known as the National Marine Fisheries Service (NMFS), is an office of the National Oceanic and Atmospheric Administration within the Department of Commerce.

MAMMALS

NAME	STATUS
Northern Long-eared Bat <i>Myotis septentrionalis</i> No critical habitat has been designated for this species. Species profile: https://ecos.fws.gov/ecp/species/9045	Endangered

BIRDS

NAME	STATUS
Roseate Tern <i>Sterna dougallii dougallii</i> Population: Northeast U.S. nesting population No critical habitat has been designated for this species. Species profile: https://ecos.fws.gov/ecp/species/2083	Endangered

CRITICAL HABITATS

THERE ARE NO CRITICAL HABITATS WITHIN YOUR PROJECT AREA UNDER THIS OFFICE'S JURISDICTION.

YOU ARE STILL REQUIRED TO DETERMINE IF YOUR PROJECT(S) MAY HAVE EFFECTS ON ALL ABOVE LISTED SPECIES.

IPAC USER CONTACT INFORMATION

Agency: Portsmouth city

Name: Deb Coon

Address: 150 Dow Street

City: Manchester

State: NH

Zip: 03101

Email: dcoon@hoyletanner.com

Phone: 6034605154

LEAD AGENCY CONTACT INFORMATION

Lead Agency: Army Corps of Engineers



United States Department of the Interior



FISH AND WILDLIFE SERVICE
New England Ecological Services Field Office
70 Commercial Street, Suite 300
Concord, NH 03301-5094
Phone: (603) 223-2541 Fax: (603) 223-0104

In Reply Refer To:

June 12, 2023

Project code: 2023-0010149

Project Name: Repairs to the Maplewood Avenue Bridge over North Mill Pond, Portsmouth, NH

Federal Nexus: yes

Federal Action Agency (if applicable): Army Corps of Engineers

Subject: Technical assistance for 'Repairs to the Maplewood Avenue Bridge over North Mill Pond, Portsmouth, NH'

Dear Deb Coon:

This letter records your determination using the Information for Planning and Consultation (IPaC) system provided to the U.S. Fish and Wildlife Service (Service) on June 12, 2023, for 'Repairs to the Maplewood Avenue Bridge over North Mill Pond, Portsmouth, NH' (here forward, Project). This project has been assigned Project Code 2023-0010149 and all future correspondence should clearly reference this number. **Please carefully review this letter. Your Endangered Species Act (Act) requirements are not complete.**

Ensuring Accurate Determinations When Using IPaC

The Service developed the IPaC system and associated species' determination keys in accordance with the Endangered Species Act of 1973 (ESA; 87 Stat. 884, as amended; 16 U.S.C. 1531 et seq.) and based on a standing analysis. All information submitted by the Project proponent into the IPaC must accurately represent the full scope and details of the Project. Failure to accurately represent or implement the Project as detailed in IPaC or the Northern Long-eared Bat Rangewide Determination Key (Dkey), invalidates this letter.

Determination for the Northern Long-Eared Bat

Based upon your IPaC submission and a standing analysis, your project is not reasonably certain to cause incidental take of the northern long-eared bat. Unless the Service advises you within 15 days of the date of this letter that your IPaC-assisted determination was incorrect, this letter verifies that the Action is not likely to result in unauthorized take of the northern long-eared bat.

Other Species and Critical Habitat that May be Present in the Action Area

The IPaC-assisted determination for the northern long-eared bat does not apply to the following ESA-protected species and/or critical habitat that also may occur in your Action area:

- Roseate Tern *Sterna dougallii dougallii* Endangered

You may coordinate with our Office to determine whether the Action may cause prohibited take of the animal species listed above. Note that if a new species is listed that may be affected by the identified action before it is complete, additional review is recommended to ensure compliance with the Endangered Species Act.

Next Step

Consultation with the Service is necessary. The project has a federal nexus (e.g., Federal funds, permit, etc.), but you are not the federal action agency or its designated (in writing) non-federal representative. Therefore, the ESA consultation status is incomplete and no project activities should occur until consultation between the Service and the Federal action agency (or designated non-federal representative), is completed.

As the federal agency or designated non-federal representative deems appropriate, they should submit their determination of effects to the Service by doing the following.

1. Log into IPaC using an agency email account and click on My Projects, click "Search by record locator" to find this Project using **566-127522740**. (Alternatively, the originator of the project in IPaC can add the agency representative to the project by using the Add Member button on the project home page.)
2. Review the answers to the Northern Long-eared Bat Range-wide Determination Key to ensure that they are accurate.
3. Click on Review/Finalize to convert the 'not likely to adversely affect' consistency letter to a concurrence letter. Download the concurrence letter for your files if needed.

If no changes occur with the Project or there are no updates on listed species, no further consultation/coordination for this project is required for the northern long-eared bat. However, the Service recommends that project proponents re-evaluate the Project in IPaC if: 1) the scope, timing, duration, or location of the Project changes (includes any project changes or amendments); 2) new information reveals the Project may impact (positively or negatively) federally listed species or designated critical habitat; or 3) a new species is listed, or critical habitat designated. If any of the above conditions occurs, additional coordination with the Service should take place before project implements any changes which are final or commits additional resources.

If you have any questions regarding this letter or need further assistance, please contact the New England Ecological Services Field Office and reference Project Code 2023-0010149 associated with this Project.

Action Description

You provided to IPaC the following name and description for the subject Action.

1. Name

Repairs to the Maplewood Avenue Bridge over North Mill Pond, Portsmouth, NH

2. Description

The following description was provided for the project 'Repairs to the Maplewood Avenue Bridge over North Mill Pond, Portsmouth, NH':

Repairs to the Maplewood Avenue Bridge over North Mill Pond, Portsmouth, NH

The approximate location of the project can be viewed in Google Maps: <https://www.google.com/maps/@43.0797049,-70.76530674241938,14z>



DETERMINATION KEY RESULT

Based on the answers provided, the proposed Action is consistent with a determination of “may affect, but not likely to adversely affect” for the Endangered northern long-eared bat (*Myotis septentrionalis*).

QUALIFICATION INTERVIEW

1. Does the proposed project include, or is it reasonably certain to cause, intentional take of the northern long-eared bat or any other listed species?

Note: Intentional take is defined as take that is the intended result of a project. Intentional take could refer to research, direct species management, surveys, and/or studies that include intentional handling/encountering, harassment, collection, or capturing of any individual of a federally listed threatened, endangered or proposed species?

No

2. Do you have post-white nose syndrome occurrence data that indicates that northern long-eared bats (NLEB) are likely to be present in the action area?

Bat occurrence data may include identification of NLEBs in hibernacula, capture of NLEBs, tracking of NLEBs to roost trees, or confirmed acoustic detections. With this question, we are looking for data that, for some reason, may have not yet been made available to U.S. Fish and Wildlife Service.

No

3. Does any component of the action involve construction or operation of wind turbines?

Note: For federal actions, answer ‘yes’ if the construction or operation of wind power facilities is either (1) part of the federal action or (2) would not occur but for a federal agency action (federal permit, funding, etc.).

No

4. Is the proposed action authorized, permitted, licensed, funded, or being carried out by a Federal agency in whole or in part?

Yes

5. Is the Federal Highway Administration (FHWA), Federal Railroad Administration (FRA), or Federal Transit Administration (FTA) funding or authorizing the proposed action, in whole or in part?

No

6. Are you an employee of the federal action agency or have you been officially designated in writing by the agency as its designated non-federal representative for the purposes of Endangered Species Act Section 7 informal consultation per 50 CFR § 402.08?

Note: This key may be used for federal actions and for non-federal actions to facilitate section 7 consultation and to help determine whether an incidental take permit may be needed, respectively. This question is for information purposes only.

No

7. Is the lead federal action agency the Environmental Protection Agency (EPA) or Federal Communications Commission (FCC)? Is the Environmental Protection Agency (EPA) or Federal Communications Commission (FCC) funding or authorizing the proposed action, in whole or in part?

No

8. Is the lead federal action agency the Federal Energy Regulatory Commission (FERC)?

No

9. Have you determined that your proposed action will have no effect on the northern long-eared bat? Remember to consider the [effects of any activities](#) that would not occur but for the proposed action.

If you think that the northern long-eared bat may be affected by your project or if you would like assistance in deciding, answer “No” below and continue through the key. If you have determined that the northern long-eared bat does not occur in your project’s action area and/or that your project will have no effects whatsoever on the species despite the potential for it to occur in the action area, you may make a “no effect” determination for the northern long-eared bat.

Note: Federal agencies (or their designated non-federal representatives) must consult with USFWS on federal agency actions that may affect listed species [50 CFR 402.14(a)]. Consultation is not required for actions that will not affect listed species or critical habitat. Therefore, this determination key will not provide a consistency or verification letter for actions that will not affect listed species. If you believe that the northern long-eared bat may be affected by your project or if you would like assistance in deciding, please answer “No” and continue through the key. Remember that this key addresses only effects to the northern long-eared bat. Consultation with USFWS would be required if your action may affect another listed species or critical habitat. The definition of [Effects of the Action](#) can be found here: <https://www.fws.gov/media/northern-long-eared-bat-assisted-determination-key-selected-definitions>

No

10. Does the action area contain any caves (or associated sinkholes, fissures, or other karst features), mines, rocky outcroppings, or tunnels that could provide habitat for hibernating northern long-eared bats?

No

11. Does the action area contain or occur within 0.5 miles of (1) talus or (2) anthropogenic or naturally formed rock crevices in rocky outcrops, rock faces or cliffs?

No

12. Is suitable summer habitat for the northern long-eared bat present within 1000 feet of project activities?

(If unsure, answer "Yes.")

Note: If there are trees within the action area that are of a sufficient size to be potential roosts for bats (i.e., live trees and/or snags ≥ 3 inches (12.7 centimeter) dbh), answer "Yes". If unsure, additional information defining suitable summer habitat for the northern long-eared bat can be found at: <https://www.fws.gov/media/northern-long-eared-bat-assisted-determination-key-selected-definitions>

Yes

13. Will the action cause effects to a covered bridge?

No

14. Does the action include the intentional exclusion of northern long-eared bats from a building or structure?

Note: Exclusion is conducted to deny bats' entry or reentry into a building. To be effective and to avoid harming bats, it should be done according to established standards. If your action includes bat exclusion and you are unsure whether northern long-eared bats are present, answer "Yes." Answer "No" if there are no signs of bat use in the building/structure. If unsure, contact your local U.S. Fish and Wildlife Services Ecological Services Field Office to help assess whether northern long-eared bats may be present. Contact a Nuisance Wildlife Control Operator (NWCO) for help in how to exclude bats from a structure safely without causing harm to the bats (to find a NWCO certified in bat standards, search the Internet using the search term "National Wildlife Control Operators Association bats"). Also see the White-Nose Syndrome Response Team's guide for bat control in structures

No

15. Does the action involve removal, modification, or maintenance of a human-made structure (barn, house, or other building) **known or suspected to contain roosting bats**?

No

16. Will the action cause construction of one or more new roads open to the public?

For federal actions, answer 'yes' when the construction or operation of these facilities is either (1) part of the federal action or (2) would not occur but for an action taken by a federal agency (federal permit, funding, etc.).

No

17. Will the action include or cause any construction or other activity that is reasonably certain to increase average daily traffic on one or more existing roads?

Note: For federal actions, answer 'yes' when the construction or operation of these facilities is either (1) part of the federal action or (2) would not occur but for an action taken by a federal agency (federal permit, funding, etc.). .

No

18. Will the action include or cause any construction or other activity that is reasonably certain to increase the number of travel lanes on an existing thoroughfare?

For federal actions, answer 'yes' when the construction or operation of these facilities is either (1) part of the federal action or (2) would not occur but for an action taken by a federal agency (federal permit, funding, etc.).

No

19. Will the proposed action involve the creation of a new water-borne contaminant source (e.g., leachate pond pits containing chemicals that are not NSF/ANSI 60 compliant)?

No

20. Will the proposed action involve the creation of a new point source discharge from a facility other than a water treatment plant or storm water system?

No

21. Will the action include drilling or blasting?

No

22. Will the action involve military training (e.g., smoke operations, obscurant operations, exploding munitions, artillery fire, range use, helicopter or fixed wing aircraft use)?

No

23. Will the proposed action involve the use of herbicides or pesticides other than herbicides (e.g., fungicides, insecticides, or rodenticides)?

No

24. Will the action include or cause activities that are reasonably certain to cause chronic nighttime noise in suitable summer habitat for the northern long-eared bat? Chronic noise is noise that is continuous or occurs repeatedly again and again for a long time.

Note: Additional information defining suitable summer habitat for the northern long-eared bat can be found at: <https://www.fws.gov/media/northern-long-eared-bat-assisted-determination-key-selected-definitions>

No

25. Does the action include, or is it reasonably certain to cause, the use of artificial lighting within 1000 feet of suitable northern long-eared bat roosting habitat?

Note: Additional information defining suitable roosting habitat for the northern long-eared bat can be found at: <https://www.fws.gov/media/northern-long-eared-bat-assisted-determination-key-selected-definitions>

No

26. Will the action include tree cutting or other means of knocking down or bringing down trees, tree topping, or tree trimming?

Yes

27. Does the action include emergency cutting or trimming of hazard trees in order to remove an imminent threat to human safety or property? See hazard tree note at the bottom of the key for text that will be added to response letters

Note: A "hazard tree" is a tree that is an immediate threat to lives, public health and safety, or improved property and has a diameter breast height of six inches or greater.

No

28. Are any of the trees proposed for cutting or other means of knocking down, bringing down, topping, or trimming suitable for northern long-eared bat roosting (i.e., live trees and/or snags ≥ 3 inches dbh that have exfoliating bark, cracks, crevices, and/or cavities)?

Yes

29. [Semantic] Does your project intersect a known sensitive area for the northern long-eared bat?

Note: The map queried for this question contains proprietary information and cannot be displayed. If you need additional information, please contact your [state agency or USFWS field office](#)

Automatically answered

No

30. Will all tree cutting/trimming or other knocking or bringing down of trees be restricted to the inactive (hibernation) season for northern long-eared bat?

Note: Inactive Season dates for spring staging/fall swarming areas can be found here: <https://www.fws.gov/media/inactive-season-dates-swarming-and-staging-areas>.

Yes

31. Will the action cause trees to be cut, knocked down, or otherwise brought down across an area greater than 10 acres?

No

32. Will the action cause trees to be cut, knocked down, or otherwise brought down in a way that would fragment a forested connection (e.g., tree line) between two or more forest patches of at least 5 acres?

The forest patches may consist of entirely contiguous forest or multiple forested areas that are separated by less than 1000' of non-forested area. A project will fragment a forested connection if it creates an unforested gap of greater than 1000'.

No

33. Will the action result in the use of prescribed fire?

No

34. Will the action cause noises that are louder than ambient baseline noises within the action area?

No

PROJECT QUESTIONNAIRE

Enter the extent of the action area (in acres) from which trees will be removed - round up to the nearest tenth of an acre. For this question, include the entire area where tree removal will take place, even if some live or dead trees will be left standing.

.01

In what extent of the area (in acres) will trees be cut, knocked down, or trimmed during the inactive (hibernation) season for northern long-eared bat? **Note:** Inactive Season dates for spring staging/fall swarming areas can be found here: <https://www.fws.gov/media/inactive-season-dates-swarming-and-staging-areas>

.01

In what extent of the area (in acres) will trees be cut, knocked down, or trimmed during the active (non-hibernation) season for northern long-eared bat? **Note:** Inactive Season dates for spring staging/fall swarming areas can be found here: <https://www.fws.gov/media/inactive-season-dates-swarming-and-staging-areas>

0

Will all potential northern long-eared bat (NLEB) roost trees (trees ≥ 3 inches diameter at breast height, dbh) be cut, knocked, or brought down from any portion of the action area greater than or equal to 0.1 acre? If all NLEB roost trees will be removed from multiple areas, select 'Yes' if the cumulative extent of those areas meets or exceeds 0.1 acre.

No

Enter the extent of the action area (in acres) from which all potential NLEB roost trees will be removed. If all NLEB roost trees will be removed from multiple areas, entire the total extent of those areas. Round up to the nearest tenth of an acre.

.01

For the area from which all potential northern long-eared bat (NLEB) roost trees will be removed, on how many acres (round to the nearest tenth of an acre) will trees be allowed to regrow? Enter '0' if the entire area from which all potential NLEB roost trees are removed will be developed or otherwise converted to non-forest for the foreseeable future.

0

Will any snags (standing dead trees) ≥ 3 inches dbh be left standing in the area(s) in which all northern long-eared bat roost trees will be cut, knocked down, or otherwise brought down?

No

Will all project activities be completed by April 1, 2024?

No

IPAC USER CONTACT INFORMATION

Agency: Portsmouth city

Name: Deb Coon

Address: 150 Dow Street

City: Manchester

State: NH

Zip: 03101

Email: dcoon@hoyletanner.com

Phone: 6034605154

LEAD AGENCY CONTACT INFORMATION

Lead Agency: Army Corps of Engineers



United States Department of the Interior



FISH AND WILDLIFE SERVICE
New England Ecological Services Field Office
70 Commercial Street, Suite 300
Concord, NH 03301-5094
Phone: (603) 223-2541 Fax: (603) 223-0104

In Reply Refer To:

June 12, 2023

Project code: 2023-0010149

Project Name: Repairs to the Maplewood Avenue Bridge over North Mill Pond, Portsmouth, NH

Federal Nexus: yes

Federal Action Agency (if applicable): Army Corps of Engineers

Subject: Federal agency coordination under the Endangered Species Act, Section 7 for 'Repairs to the Maplewood Avenue Bridge over North Mill Pond, Portsmouth, NH'

Dear Deb Coon:

This letter records your determination using the Information for Planning and Consultation (IPaC) system provided to the U.S. Fish and Wildlife Service (Service) on June 12, 2023, for "Repairs to the Maplewood Avenue Bridge over North Mill Pond, Portsmouth, NH" (here forward, Project). This project has been assigned Project Code 2023-0010149 and all future correspondence should clearly reference this number.

The Service developed the IPaC system and associated species' determination keys in accordance with the Endangered Species Act of 1973 (ESA; 87 Stat. 884, as amended; 16 U.S.C. 1531 et seq.) and based on a standing analysis. All information submitted by the Project proponent into the IPaC must accurately represent the full scope and details of the Project. Failure to accurately represent or implement the Project as detailed in IPaC or the Northeast Determination Key (DKey), invalidates this letter. To make a no effect determination, the full scope of the proposed project implementation (action) should not have any effects (either positive or negative effect(s)), to a federally listed species or designated critical habitat.

Effects of the action are all consequences to listed species or critical habitat that are caused by the proposed action, including the consequences of other activities that are caused by the proposed action. A consequence is caused by the proposed action if it would not occur but for the proposed action and it is reasonably certain to occur. Effects of the action may occur later in time and may include consequences occurring outside the immediate area involved in the action. (See § 402.17). Under Section 7 of the ESA, if a federal action agency makes a no effect determination, no further consultation with, or concurrence from, the Service is required (ESA §7). If a proposed Federal action may affect a listed species or designated critical habitat, formal consultation is required (except when the Service concurs, in writing, that a proposed action "is

not likely to adversely affect" listed species or designated critical habitat [50 CFR §402.02, 50 CFR§402.13]).

The IPaC results indicated the following species is (are) potentially present in your project area and, based on your responses to the Service's Northeast DKey, you determined the proposed Project will have the following effect determinations:

Species	Listing Status	Determination
Roseate Tern (<i>Sterna dougallii dougallii</i>)	Endangered	No effect

Conclusion If there are no updates on listed species, no further consultation/coordination for this project is required for the species identified above. However, the Service recommends that project proponents re-evaluate the Project in IPaC if: 1) the scope, timing, duration, or location of the Project changes (includes any project changes or amendments); 2) new information reveals the Project may impact (positively or negatively) federally listed species or designated critical habitat; or 3) a new species is listed, or critical habitat designated. If any of the above conditions occurs, additional consultation with the Service should take place before project implements any changes which are final or commits additional resources.

In addition to the species listed above, the following species and/or critical habitats may also occur in your project area and are not covered by this conclusion:

- Northern Long-eared Bat *Myotis septentrionalis* Endangered

To complete consultation for species that have reached a "May Affect" determination and/or species may occur in your project area and are not covered by this conclusion, please visit the "New England Field Office Endangered Species Project Review and Consultation" website for step-by-step instructions on how to consider effects on these listed species and/or critical habitats, avoid and minimize potential adverse effects, and prepare and submit a project review package if necessary: <https://www.fws.gov/office/new-england-ecological-services/endangered-species-project-review>

Please Note: If the Action may impact bald or golden eagles, additional coordination with the Service under the Bald and Golden Eagle Protection Act (BGEPA) (54 Stat. 250, as amended, 16 U.S.C. 668a-d) by the prospective permittee may be required. Please contact the Migratory Birds Permit Office, (413) 253-8643, or PermitsR5MB@fws.gov, with any questions regarding potential impacts to Eagles.

If you have any questions regarding this letter or need further assistance, please contact the New England Ecological Services Field Office and reference the Project Code associated with this Project.

Action Description

You provided to IPaC the following name and description for the subject Action.

1. Name

Repairs to the Maplewood Avenue Bridge over North Mill Pond, Portsmouth, NH

2. Description

The following description was provided for the project 'Repairs to the Maplewood Avenue Bridge over North Mill Pond, Portsmouth, NH':

Repairs to the Maplewood Avenue Bridge over North Mill Pond, Portsmouth, NH

The approximate location of the project can be viewed in Google Maps: <https://www.google.com/maps/@43.0797049,-70.76530674241938,14z>

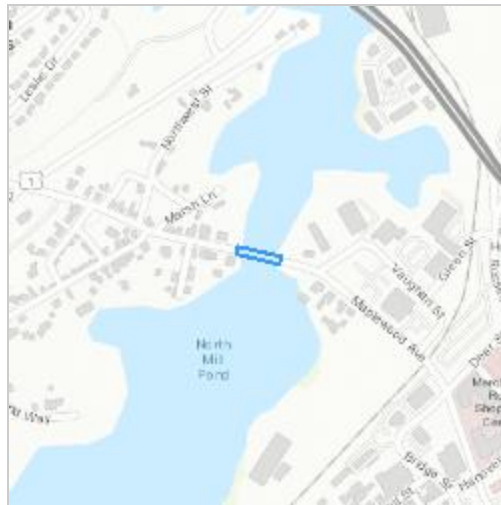

QUALIFICATION INTERVIEW

1. As a representative of this project, do you agree that all items submitted represent the complete scope of the project details and you will answer questions truthfully?

Yes

2. Does the proposed project include, or is it reasonably certain to cause, intentional take of listed species?

Note: This question could refer to research, direct species management, surveys, and/or studies that include intentional handling/encountering, harassment, collection, or capturing of any individual of a federally listed threatened, endangered, or proposed species.

No

3. Is the action authorized, permitted, licensed, funded, or being carried out by a Federal agency in whole or in part?

Yes

4. Is the Federal Highway Administration (FHWA), Federal Railroad Administration (FRA), or Federal Transit Administration (FTA) the lead agency for this project?

No

5. Are you including in this analysis all impacts to federally listed species that may result from the entirety of the project (not just the activities under federal jurisdiction)?

Note: If there are project activities that will impact listed species that are considered to be outside of the jurisdiction of the federal action agency submitting this key, contact your local Ecological Services Field Office to determine whether it is appropriate to use this key. If your Ecological Services Field Office agrees that impacts to listed species that are outside the federal action agency's jurisdiction will be addressed through a separate process, you can answer yes to this question and continue through the key.

Yes

6. Are you the lead federal action agency or designated non-federal representative requesting concurrence on behalf of the lead Federal Action Agency?

No

7. Is the lead federal action agency the Environmental Protection Agency (EPA) or Federal Communications Commission (FCC)?

No

8. Will the proposed project involve the use of herbicide where listed species are present?

No

9. Are there any caves or anthropogenic features suitable for hibernating or roosting bats within the area expected to be impacted by the project?

No

10. Does any component of the project associated with this action include structures that may pose a collision risk to **birds** (e.g., land-based or offshore wind turbines, communication towers, high voltage transmission lines, any type of towers with or without guy wires)?

Note: For federal actions, answer 'yes' if the construction or operation of wind power facilities is either (1) part of the federal action or (2) would not occur but for a federal agency action (federal permit, funding, etc.).

No

11. Does any component of the project associated with this action include structures that may pose a collision risk to **bats** (e.g., land-based wind turbines)?

Note: For federal actions, answer 'yes' if the construction or operation of wind power facilities is either (1) part of the federal action or (2) would not occur but for a federal agency action (federal permit, funding, etc.).

No

12. Will the proposed project result in permanent changes to water quantity in a stream or temporary changes that would be sufficient to result in impacts to listed species?

For example, will the proposed project include any activities that would alter stream flow, such as water withdrawal, hydropower energy production, impoundments, intake structures, diversion structures, and/or turbines? Projects that include temporary and limited water reductions that will not displace listed species or appreciably change water availability for listed species (e.g. listed species will experience no changes to feeding, breeding or sheltering) can answer "No". Note: This question refers only to the amount of water present in a stream, other water quality factors, including sedimentation and turbidity, will be addressed in following questions.

No

13. Will the proposed project affect wetlands where listed species are present?

This includes, for example, project activities within wetlands, project activities within 300 feet of wetlands that may have impacts on wetlands, water withdrawals and/or discharge of contaminants (even with a NPDES).

Yes

14. Will the proposed project activities (including upland project activities) occur within 0.5 miles of the water's edge of a stream or tributary of a stream where listed species may be present?

Yes

15. Will the proposed project directly affect a streambed (below ordinary high water mark (OHWM)) of the stream or tributary where listed species may be present?

Yes

16. Will the proposed project bore underneath (directional bore or horizontal directional drill) a stream where listed species may be present?

No

17. Will the proposed project involve a new point source discharge into a stream or change an existing point source discharge (e.g., outfalls; leachate ponds) where listed species may be present?

No

18. Will the proposed project involve the removal of excess sediment or debris, dredging or in-stream gravel mining where listed species may be present?

No

19. Will the proposed project involve the creation of a new water-borne contaminant source where listed species may be present?

Note New water-borne contaminant sources occur through improper storage, usage, or creation of chemicals. For example: leachate ponds and pits containing chemicals that are not NSF/ANSI 60 compliant have contaminated waterways. Sedimentation will be addressed in a separate question.

No

20. Will the proposed project involve perennial stream loss, in a stream or tributary of a stream where listed species may be present, that would require an individual permit under 404 of the Clean Water Act?

No

21. Will the proposed project involve blasting where listed species may be present?

No

22. Will the proposed project include activities that could result in an increase to recreational fishing or potentially affect fish movement temporarily or permanently (including fish stocking, harvesting, or creation of barriers to fish passage)?

No

23. Will the proposed project involve earth moving that could cause erosion and sedimentation, and/or contamination along a stream or tributary of a stream where listed species may be present?

Note Answer "Yes" to this question if erosion and sediment control measures will be used to protect the stream.

Yes

24. Will the proposed project involve vegetation removal within 200 feet of a perennial stream bank where listed species may be present?

Yes

25. Will erosion and sedimentation control Best Management Practices (BMPs) associated with applicable state and/or Federal permits, be applied to the project? If BMPs have been provided by and/or coordinated with and approved by the appropriate Ecological Services Field Office, answer "Yes" to this question.

Yes

26. Will the proposed project result in changes to beach dynamics that may modify formation of habitat over time?

Note: Examples of projects that result in changes to beach dynamics include 1) construction of offshore breakwaters and groins; 2) mining of sand from an updrift ebb tidal delta; 3) removing or adding beach sands; and 4) projects that stabilize dunes (including placement of sand fences or planting vegetation).

No

27. [Hidden Semantic] Is the project area located within the roseate tern AOI?

Automatically answered

Yes

28. If you have determined that the roseate tern is unlikely to occur within your project's action area or that your project is unlikely to have any potential effects on the roseate tern, you may wish to make a "no effect" determination for the roseate tern. Additional guidance on how to make this decision can be found in the project review section of your local Ecological Services Field Office's website. CBFO: <https://www.fws.gov/office/chesapeake-bay-ecological-services/project-review> ; MEFO: <https://www.fws.gov/office/maine-ecological-services> ; NJFO: <https://www.fws.gov/office/new-jersey-ecological-services/new-jersey-field-office-project-review-guide> ; NEFO: <https://www.fws.gov/office/new-england-ecological-services/endangered-species-project-review#Step5> ; WVFO: <https://www.fws.gov/office/west-virginia-ecological-services/project-planning>. If you are unsure, answer "No" and continue through the key.

Would you like to make a no effect determination for the roseate tern?

No

29. Is this an aquaculture project?

No

30. Is this a coastal project that has an action area that is less than one-half acre?

Note: These projects may include marker buoys, moorings, navigational structures, docks, piers, floats, boat ramps, private dredging, boat houses, lobster pound, or shoreline work.

No

31. Will project activities be conducted during the time of year when roseate terns are likely to be present?

Note: roseate terns are likely to be present in Maine May 1 through Sept. 1; and in Connecticut, Massachusetts, New Hampshire, and Rhode Island April 15 through Oct. 15.

Yes

32. Will the proposed project affect suitable habitat for roseate terns nesting (barrier islands with dense vegetation or rocks to serve as shelter)?

No

33. Will the proposed project affect suitable habitat for roseate terns foraging (nearshore shallow waters, shoals and shoals in offshore waters)?
No
34. Will the proposed project affect suitable habitat for roseate terns roosting (rocky habitat on coastal islands)?
No
35. Will the proposed project affect suitable habitat for roseate terns staging (sandy barrier beaches, often on distal tips, primarily in NY and NE)?
No
36. Will the proposed project involve ground disturbance (e.g., vehicles, tracked equipment, excavating, grading, placing fill material, etc.) in roseate tern foraging, nesting, roosting or staging habitat while terns are likely to be present (April 1 - September 30)?
No
37. Does the action area include suitable habitat for migrating roseate terns (sandy beaches, coastal islands)?
No
38. [Semantic] Does the project intersect the Virginia big-eared bat critical habitat?
Automatically answered
No
39. [Semantic] Does the project intersect the Indiana bat critical habitat?
Automatically answered
No
40. [Semantic] Does the project intersect the candy darter critical habitat?
Automatically answered
No
41. [Semantic] Does the project intersect the diamond darter critical habitat?
Automatically answered
No
42. [Semantic] Does the project intersect the Big Sandy crayfish critical habitat?
Automatically answered
No
43. [Hidden Semantic] Does the project intersect the Guyandotte River crayfish critical habitat?
Automatically answered
No
44. Do you have any other documents that you want to include with this submission?
No
-

PROJECT QUESTIONNAIRE

1. Approximately how many acres of trees would the proposed project remove?
.01
 2. Approximately how many total acres of disturbance are within the disturbance/
construction limits of the proposed project?
.19
 3. Briefly describe the habitat within the construction/disturbance limits of the project site.
Tidal estuary and stream crossing that includes limited areas of tidal marsh and tidal flats.
-

IPAC USER CONTACT INFORMATION

Agency: Portsmouth city
Name: Deb Coon
Address: 150 Dow Street
City: Manchester
State: NH
Zip: 03101
Email: dcoon@hoyletanner.com
Phone: 6034605154

LEAD AGENCY CONTACT INFORMATION

Lead Agency: Army Corps of Engineers

**Responses from NHDHR for Request for
Project Review**

Please mail the completed form and required material to:

New Hampshire Division of Historical Resources
State Historic Preservation Office
Attention: Review & Compliance
19 Pillsbury Street, Concord, NH 03301-3570

RECEIVED AUG 23 2022

DHR Use Only	
R&C #	19177
Log In Date	8/23/22
Response Date	8/26/22
Sent Date	8/31/22

Request for Project Review by the New Hampshire Division of Historical Resources

- This is a new submittal
 This is additional information relating to DHR Review & Compliance (R&C) #:

GENERAL PROJECT INFORMATION

Project Title: Repair of the Maplewood Avenue Bridge over North Mill Pond

Project Location: Maplewood Avenue

City/Town Portsmouth Tax Map 123 & 124 Lot # N/A

NH State Plane - Feet Geographic Coordinates: Easting 1225040.65 Northing 212559.14
(See RPR Instructions and R&C FAQs for guidance.)

Lead Federal Agency and Contact (if applicable) US Army Corps of Engineers
(Agency providing funds, licenses, or permits)
Permit Type and Permit or Job Reference # Wetland Permit

State Agency and Contact (if applicable) NH Dept of Environmental Services
Permit Type and Permit or Job Reference # Wetland Permit

APPLICANT INFORMATION

Applicant Name City of Portsmouth / David Desfosses

Mailing Address 680 Peverly Hill Rd Phone Number 603.427.1530

City Portsmouth State NH Zip 03801 Email didesfosses@cityofportsmouth.com

CONTACT PERSON TO RECEIVE RESPONSE

Name/Company Hoyle, Tanner & Associates, Inc. / Kimberly Peace

Mailing Address 150 Dow Street Phone Number 603.460.5205

City Manchester State NH Zip 03101 Email kpeace@hoyletanner.com

This form is updated periodically. Please download the current form at www.nh.gov/nhdhr/review. Please refer to the Request for Project Review Instructions for direction on completing this form. Submit one copy of this project review form for each project for which review is requested. Please include a self-addressed stamped envelope. Project submissions will not be accepted via facsimile or e-mail. This form is required. Review request form must be complete for review to begin. Incomplete forms will be sent back to the applicant without comment. Please be aware that this form may only initiate consultation. For some projects, additional information will be needed to complete the Section 106 review. All items and supporting documentation submitted with a review request, including photographs and publications, will be retained by the DHR as part of its review records. Items to be kept confidential should be clearly identified. For questions regarding the DHR review process and the DHR's role in it, please visit our website at: www.nh.gov/nhdhr/review or contact the R&C Specialist at marika.s.labash@dncr.nh.gov or 603.271.3558.

PROJECTS CANNOT BE PROCESSED WITHOUT THIS INFORMATION

Project Boundaries and Description

- Attach the Project Mapping *using EMMIT or relevant portion of a 7.5' USGS Map.* (See RPR Instructions and R&C FAQs for guidance.)
- Attach a detailed narrative description of the proposed project.
- Attach a site plan. The site plan should include the project boundaries and areas of proposed excavation.
- Attach photos of the project area (overview of project location and area adjacent to project location, and specific areas of proposed impacts and disturbances.) (Informative photo captions are requested.)
- A DHR records search must be conducted to identify properties within or adjacent to the project area. Provide records search results via EMMIT or in Table 1. (Blank table forms are available on the DHR website.) Please note, using EMMIT Guest View for an RPR records search does not provide the necessary information needed for DHR review.
EMMIT or in-house records search conducted on 05/17/2022.

Architecture

Are there any buildings, structures (bridges, walls, culverts, etc.) objects, districts or landscapes within the project area? Yes No
If no, skip to Archaeology section. If yes, submit all of the following information:

Approximate age(s): Oldest structures bordering APE range from 102 – 219 years

- Photographs of *each* resource or streetscape located within the project area, with captions, along with a mapped photo key. (Digital photographs are accepted. All photographs must be clear, crisp and focused.)
- If the project involves rehabilitation, demolition, additions, or alterations to existing buildings or structures, provide additional photographs showing detailed project work locations. (i.e. Detail photo of windows if window replacement is proposed.)

Archaeology

Does the proposed undertaking involve ground-disturbing activity? Yes No
If yes, submit all of the following information:

- Description of current and previous land use and disturbances.
- Available information concerning known or suspected archaeological resources within the project area (such as cellar holes, wells, foundations, dams, etc.)

Please note that for many projects an architectural and/or archaeological survey or other additional information may be needed to complete the Section 106 process.

DHR Comment/Finding Recommendation *This Space for Division of Historical Resources Use Only*

- Insufficient information to initiate review. Additional information is needed in order to complete review.
- No Potential to cause Effects No Historic Properties Affected No Adverse Effect Adverse Effect

Comments:

This finding is for bridge repair only. Additional consultation required should bridge be replaced in the future.

If plans change or resources are discovered in the course of this project, you must contact the Division of Historical Resources as required by federal law and regulation.

Authorized Signature: *Necchi Miller DSR*

Date: *8/26/22*

Please mail the completed form and required material to:

New Hampshire Division of Historical Resources
State Historic Preservation Office
Attention: Review & Compliance
172 Pembroke Road, Concord, NH 03301

RECEIVED JUN 14 2023

DHR Use Only	
R&C #	14177M
Log In Date	6/14/23
Response Date	7/5/23
Sent Date	7/5/23

Request for Project Review by the New Hampshire Division of Historical Resources

- This is a new submittal
 This is additional information relating to DHR Review & Compliance (R&C) #: 14177

GENERAL PROJECT INFORMATION
Project Title: Repair of the Maplewood Avenue Bridge over North Mill Pond
Project Location: Maplewood Avenue
City/Town Portsmouth Tax Map 123 & 124 Lot # N/A
NH State Plane - Feet Geographic Coordinates: Easting 1225040.65 Northing 212559.14 (See RPR Instructions and R&C FAQs for guidance.)
Lead Federal Agency and Contact (if applicable) US Army Corps of Engineers (Agency providing funds, licenses, or permits) Permit Type and Permit or Job Reference # Wetland Permit
State Agency and Contact (if applicable) NH Dept of Environmental Services Permit Type and Permit or Job Reference # Wetland Permit
APPLICANT INFORMATION
Applicant Name City of Portsmouth / David Desfosses
Mailing Address 680 Peverly Hill Rd Phone Number 603.427.1530
City Portsmouth State NH Zip 03801 Email djdesfosses@cityofportsmouth.com
CONTACT PERSON TO RECEIVE RESPONSE
Name/Company Hoyle, Tanner & Associates, Inc. / Deb Coon
Mailing Address 150 Dow Street Phone Number 603.460.5154
City Manchester State NH Zip 03101 Email dcoon@hoyletanner.com

This form is updated periodically. Please download the current form at www.nh.gov/nhdhr/review. Please refer to the Request for Project Review Instructions for direction on completing this form. Submit one copy of this project review form for each project for which review is requested. Please include a self-addressed stamped envelope. Project submissions will not be accepted via facsimile or e-mail. This form is required. Review request form must be complete for review to begin. Incomplete forms will be sent back to the applicant without comment. Please be aware that this form may only initiate consultation. For some projects, additional information will be needed to complete the Section 106 review. All items and supporting documentation submitted with a review request, including photographs and publications, will be retained by the DHR as part of its review records. Items to be kept confidential should be clearly identified. For questions regarding the DHR review process and the DHR's role in it, please visit our website at: www.nh.gov/nhdhr/review or contact the R&C Specialist at marika.s.labash@dncr.nh.gov.

PROJECTS CANNOT BE PROCESSED WITHOUT THIS INFORMATION

Project Boundaries and Description

- Attach the Project Mapping using EMMIT or relevant portion of a 7.5' USGS Map.
Attach a detailed narrative description of the proposed project.
Attach a site plan. The site plan should include the project boundaries and areas of proposed excavation.
Attach photos of the project area (overview of project location and area adjacent to project location, and specific areas of proposed impacts and disturbances.)
A DHR records search must be conducted to identify properties within or adjacent to the project area. Provide records search results via EMMIT or in Table 1.

Architecture

Are there any buildings, structures (bridges, walls, culverts, etc.) objects, districts or landscapes within the project area? Yes No
If no, skip to Archaeology section. If yes, submit all of the following information:

Approximate age(s):

- Photographs of each resource or streetscape located within the project area, with captions, along with a mapped photo key.
If the project involves rehabilitation, demolition, additions, or alterations to existing buildings or structures, provide additional photographs showing detailed project work locations.

Archaeology

Does the proposed undertaking involve ground-disturbing activity? Yes No
If yes, submit all of the following information:

- Description of current and previous land use and disturbances.
Available information concerning known or suspected archaeological resources within the project area (such as cellar holes, wells, foundations, dams, etc.)

Please note that for many projects an architectural and/or archaeological survey or other additional information may be needed to complete the Section 106 process.

DHR Comment/Finding Recommendation This Space for Division of Historical Resources Use Only

- Insufficient information to initiate review. Additional information is needed in order to complete review.
No Potential to cause Effects No Historic Properties Affected No Adverse Effect Adverse Effect

Comments:
[Handwritten signature and date]

If plans change or resources are discovered in the course of this project, you must contact the Division of Historical Resources as required by federal law and regulation.

Authorized Signature: [Handwritten Signature] Date: 7/5/23

**Wetland Delineation Report, Functional
Assessment & Site Photos**

TES Environmental Consultants, LLC

March 30, 2021

Ref: TES JN 19-0168

Mr. William Doucet, President
Doucet Survey, Inc.
2 Commerce Drive, Suite 202
Bedford, NH 03110

Re: Environmental Services (Wetland Description and Functions and Values Assessment)
Maplewood Avenue Over North Mill Pond, Portsmouth, New Hampshire
NHDOT Bridge No. 231/103

Dear Mr. Doucet:

TES Environmental Consultants, L.L.C. (TES) has prepared this report to document the physical and biological characteristics of the wetlands and surrounding lands in the vicinity of the proposed replacement of the existing culvert at Maplewood Avenue Over North Mill Pond in Portsmouth, New Hampshire, and to evaluate the functions and values associated with those wetlands. These observations are provided in support of the Survey Scope of Services related to the proposed project.

An on-site investigation was performed by TES on February 28, 2020 to delineate the boundaries of wetlands in the vicinity of the culvert (Figure 1) and to observe the characteristics of the wetlands and the upland portion of the surroundings. The wetland delineation was performed according to the standards of the Corps of Engineers Wetland Delineation Manual and the Regional Supplement to the Corps of Engineers Wetland Delineation Manual: Northcentral and Northeast Region, Version 2.0, January 2012, US Army Corps of Engineers. All wetlands in the survey area consist of coastal resources, therefore the limits of jurisdictional wetlands were identified as the highest observable tide line (HOTL) as defined at Env-Wt 602.23. The observations made during this field effort were during the mid-incoming tide, and together with the following published information, form the basis for this wetland functional assessment:

- USGS Portsmouth, NH-ME Quadrangle, 7.5 minute series topographic map
- Aerial photographs from Google Earth and other sources
- USDA-NRCS Soil Survey of Rockingham County, New Hampshire (via Web Soil Survey)
- National Wetlands Inventory map
- The New Hampshire Department of Environmental Services (NHDES) Wetlands Permit Planning Tool (WPPT)
- NH Natural Heritage Program Datacheck Program
- US Army Corps of Engineers The Highway Methodology Workbook – Supplement

Site Characterization

Uplands. The upland areas in the vicinity of this survey area are primarily in urban residential (to the west) and commercial/industrial use to the east (Figure 2). Essentially no undeveloped land exists in the vicinity of the site, although North Cemetery lies approximately 500 feet to the southeast. Trees exist

TES Environmental Consultants, LLC

only in yards and small roadside spaces, with boxelder (*Acer negundo*) and weeping willow (*Salix babylonica*) predominant, and choke cherry (*Prunus virginiana*), black locust (*Robinia pseudoacacia*), and staghorn sumac (*Rhus typhina*) present as shrub species. Two invasive shrub species are present within the project site: glossy buckthorn (*Frangula alnus*) and multiflora rose (*Rosa multiflora*). Two invasive vines are also present – Oriental bittersweet (*Celastrus orbiculatus*), and black swallowwort (*Cynanchum louiseae*). Herbaceous species present in the upland areas include turf grasses and Canada goldenrod (*Solidago canadensis*).

Upland soils in the vicinity of the survey area are shown in the Soil Survey of Rockingham County as being Urban Land (699) to the east of the culvert, and Urban Land-Canton complex (799) to the west. Canton fine sandy loam is a sandy soil formed in loose glacial till deposits. Urban Land components are developed lands, most likely having soils similar to Canton.

Wetlands. On February 28, 2020 a TES wetland scientist delineated and flagged the boundaries of the HOTL within the project survey area with numbered pink and black striped flags for location by ground survey and depiction on site plans. The principal jurisdictional wetland feature within the survey area consists of North Mill Pond (Figures 3 and 4) which is identified as Estuarine Water on the WPPT, with small, limited fringe areas of Irregularly Flooded (Tidal) Marsh and Tidal Flats in the vicinity of the project area. The project site lies approximately 1,500 feet south of the Piscataqua River at the Sarah Mildred Long Bridge on US Route 1 Bypass. Tidal Flats predominate landward from Maplewood Avenue, and Estuarine Water occupies most of the seaward portion of North Mill Pond.

Under the U.S. Fish and Wildlife Service's Classification of Wetlands and Deepwater Habitats of the United States (Cowardin et al., 1979), the Tidal Flats would be classified as Estuarine, Intertidal, Unconsolidated Shore, Mud, Regularly Flooded (E2US3N), and the Estuarine Water portions would be classified as Estuarine, Subtidal, Unconsolidated Bottom, Subtidal (E1UBL). The latter areas have a cobble bottom in the vicinity of the culvert, where tidal currents are strongest, and mud further away. Riprap is present along both sides of the Maplewood Avenue causeway, and rockweed (*Ascophyllum nodosum*) grows on the riprap and other rocky surfaces (Figure 5) in the project vicinity. Salt marsh cordgrass (*Spartina alterniflora*) grows in unconsolidated material (Figure 6) in the intertidal zone in only narrow strips in scattered areas near the project site. No eelgrass beds, shellfish beds, or oyster restoration beds are located near the project area.

No fish were observed within North Mill Pond, although various species such as winter flounder (*Pseudopleuronectes americanus*), juvenile (snapper) bluefish (*Pomatomus saltatrix*), and baitfish such as killifish (*Fundulus* spp.) and common mummichog (*Fundulus heteroclitus*) may be expected to occur seasonally. Various wading birds, shore birds, and waterfowl may also be expected to utilize North Mill Pond and its tidal flats seasonally.

Vernal Pool. No vernal pools were observed within the vicinity of the Maplewood Avenue Over North Mill Pond survey area, applying the following definition and methodologies: New Hampshire Department of Environmental Service definition of vernal pool at Env-Wt 101.106; delineation methods at Env-Wt 301.01(f); and guidelines for identifying and describing vernal pools given in "Identification and Documentation of Vernal Pools in New Hampshire" published by the New Hampshire Fish and Game Department. It is possible that vernal pool habitat is present in the forested floodplain wetlands

TES Environmental Consultants, LLC

further away from the survey corridor, although the depth of floodwaters during the field survey precluded observations in those areas.

Invasive Plant Species. The lands within the survey area for this project were investigated for the potential presence of invasive plants identified in the New Hampshire Department of Transportation (NHDOT) Best Management Practices for Roadside Invasive Plants. Four invasive plant species were observed in the survey area: Oriental bittersweet (*Celastrus orbiculatus*), glossy buckthorn (*Frangula alnus*), multiflora rose (*Rosa multiflora*), and black swallowwort (*Cynanchum louiseae*). Oriental bittersweet, glossy buckthorn, and multiflora rose are common in the uplands in the northwest quadrant of the survey area, and black swallowwort is present all along the north side of Maplewood Avenue. The extensive nature of the colonization of each of these invasive plants, along with the location of many of them on adjacent private property and along the shoreline extending well away from the project site, lead to a recommendation of no attempts to control these invasive species. Soil and plant material removed from this site, however, should not be re-used on site or on other sites, but rather should be disposed of in accordance with the New Hampshire Department of Transportation's Best Management Practices for Roadside Invasive Plants (2008).

Wetland Functional Assessment Methodology

Wetland functions and values, and their significance were evaluated using the US Army Corps Highway Methodology guidelines. The following is a list of the 14 wetland functions and values with a brief description of each.

1. **Groundwater Recharge** should relate to the potential for the wetland to contribute water to an aquifer (often combined with the following).
2. **Groundwater Discharge** should relate to the potential for the wetland to serve as an area where ground water can be discharged to the surface.
3. **Floodflow Alteration:** This function considers the effectiveness of the wetland in reducing flood damage by attenuation of floodwaters for prolonged periods following precipitation events.
4. **Fish and Shellfish Habitat:** This function considers the effectiveness of seasonal or permanent water bodies associated with the wetland in question for fish and shell fish habitat.
5. **Sediment/Toxicant/Pathogen Retention:** This function reduces or prevents degradation of water quality. It relates to the effectiveness of the wetland as a trap for sediments, toxicants or pathogens.
6. **Nutrient Removal/Retention/Transformation:** This function relates to the effectiveness of the wetland to prevent adverse effects of excess nutrients entering aquifers or surface waters such as ponds, lakes, streams, rivers or estuaries.
7. **Production Export:** This function relates to the effectiveness of the wetland to produce food or usable products for humans or other living organisms.
8. **Sediment/Shoreline Stabilization:** This function relates to the effectiveness of a wetland to stabilize stream banks and shorelines against erosion.
9. **Wildlife Habitat:** This function considers the effectiveness of the wetland to provide habitat for various types and populations of animals typically associated with wetlands and the wetland edge. Both resident and or migrating species must be considered.
10. **Recreation:** This value considers the effectiveness of the wetland and associated watercourses to provide recreational opportunities such as canoeing, boating, fishing, hunting and other active or

TES Environmental Consultants, LLC

passive recreational activities. Consumptive opportunities consume or diminish the plants, animals or other resources that are intrinsic to the wetland, whereas non-consumptive opportunities do not.

- 11. Educational/Scientific Value:** This value considers the effectiveness of the wetland as a site for an “outdoor classroom” or as a location for scientific study or research.
- 12. Uniqueness/Heritage:** This value relates to the effectiveness of the wetland or its associated water bodies to produce certain special values. Special values may include such things as archeological sites, unusual aesthetic quality, historical events, or unique plants, animals, or geological features.
- 13. Visual Quality/Aesthetics:** This value relates to the visual and aesthetic qualities of the wetland.
- 14. Threatened or Endangered Species Habitat:** This value relates to the effectiveness of the wetland or associated water bodies to support threatened or endangered species.

Wetland Functions and Values in the Survey Area

The functions and values of the wetland resources in the survey area are associated with North Mill Pond and contiguous wetlands landward and seaward from the site.

Of the 14 recognized potential functions and values of wetlands, 8 are considered to be present at some level at the location of this project, of which 4 rise to principal or significant levels within this wetland resource:

- sediment/toxicant retention,
- nutrient removal/transformation,
- sediment/shoreline stabilization, and
- visual quality/aesthetics.

Principal Functions and Values.

Sediment/toxicant retention potential is present at a principal level within the North Mill Pond wetland system due in large part to the low gradient of Pond bottom and extensive mud flats. The slow water flow present in most of the Pond (except at the Maplewood Avenue culvert) during incoming and outgoing tides, along with the Pond sediments, provide potential for settling of sediment and toxicants, as well as binding of toxicants to Pond sediment. Potential sources of sediment and toxicants are present within the Pond watershed.

Nutrient removal/transformation is also considered to be present at a principal level at this location. This function generally follows sediment/toxicant retention, as both require a wetland having a low gradient and slow flowing water. The North Mill Pond does generally lack sufficient vegetation to slow water flow, and to provide significant uptake of excessive nutrients, however. Potential sources of excess nutrients are present within the Pond watershed.

Sediment/shoreline stabilization is a function clearly provided to some degree by the wetlands along the banks of North Mill Pond, although mechanical stabilization including riprap and retaining walls are prominent in the vicinity of the Maplewood Avenue causeway. Stable bank soils contribute to reduced sediment entering downgradient channels with silt, maintaining their ability to convey flows and boat traffic.

TES Environmental Consultants, LLC

Visual quality/aesthetics is a value considered to be present at a significant level at this location due to the presence of expansive surface waters, and a public road elevated above the water offering an open vista. This affords the public opportunities to view the setting while travelling along Maplewood Avenue, the primary public viewing location.

Functions and Values Present at Moderate Levels. Four potential functions and values of wetlands are considered to be present at moderate but not principal levels at this location:

- fish and shellfish habitat,
- production export,
- wildlife habitat, and
- recreation.

Fish and shellfish habitat is considered to be present, or potentially present, at moderate levels within North Mill Pond due to the presence of permanent surface water connected to the Piscataqua River. Some marine or estuarine fish species may inhabit the Pond seasonally at some point in their life cycle, although the minimal submerged and emergent vegetation in the Pond limits potential food and cover. The existing Maplewood Avenue culvert is sufficiently wide to allow fish passage. No fish or shellfish were noted during the field investigation, but some examples of fish that may occur seasonally include winter flounder (*Pseudopleuronectes americanus*), juvenile (snapper) bluefish (*Pomatomus saltatrix*), and baitfish such as killifish (*Fundulus* spp.) and common mummichog (*Fundulus heteroclitus*). The sole tributary to North Mill Pond is Hodgson Brook, and no significant fresh surface waters exist along that drainageway, limiting potential for anadromous or catadromous fish usage.

Production export consists of the transport of vegetation or its decomposing material from a wetland to connected wetlands or surface waters. High potential for wetlands to perform production export is typically exemplified by high levels of vegetative production within a wetland coupled with a broad pathway for that production to be conveyed from that wetland to another wetland or water body. There is minimal vegetative growth with North Mill Pond or in wetlands along its shores, and therefore little export of vegetation occurs here, although a limited amount occurs from the small fringe marsh vegetation (primarily *Spartina alterniflora*) and submerged vegetation such as rockweed (*Ascophyllum nodosum*).

Wildlife habitat is a function related to all of the physical and biological elements of a wetland complex and its surrounding landscapes. The setting of North Mill Pond and associated wetlands within a highly-developed area corridor detracts greatly from its overall habitat potential. However, the significant open water (especially at high tide) provides potential resting areas for migrating waterfowl, and shorebirds and wading birds may find limited foraging habitat along the shore and on exposed mud flats. For the purposes of wetland function and values assessments, the function of wildlife habitat focuses on habitat for wildlife dependent on wetlands for part or all of their life cycles.

Recreation potential related to the wetland resources present at this location relate primarily to potential active recreation (fishing, canoe/kayak use) related to North Mill Pond, and passive recreation potentially provided by viewing the open vista or possibly birding from Maplewood Avenue, which has sidewalks along both sides. The primary limiting factor for both active and passive recreation in this location is the general lack of public access. Metered parallel parking is present off the eastern end of

TES Environmental Consultants, LLC

the survey corridor, although little visual interest is present for passive public recreation. The existing culvert appears to provide sufficient width and overhead clearance for the passage of small craft such as canoes or kayaks, although during peak tidal flow the current may be too strong to paddle against, and at high tide the overhead clearance may be insufficient for passage.

Functions and Values Absent or Present at Negligible Levels. Five potential functions and values of wetlands are considered to be absent or present at negligible levels at this location:

- groundwater recharge and discharge,
- floodflow alteration
- educational/scientific value,
- uniqueness/heritage value, and
- endangered species habitat.

Groundwater recharge and discharge are generally considered insignificant functions in Estuarine environments such as North Mill Pond. Coastal areas may have brackish groundwater, recharged by coastal surface waters. Fresh groundwater from inland areas “pushes” against this brackish groundwater, and the brackish front may push inland during periods of little rainfall, or seaward during periods of heavier rainfall. Over time, rising sea levels may increase saltwater intrusion into coastal aquifers that were previously exclusively or mostly freshwater, rendering that groundwater unpotable at least until freshwater recharge pushes out the salt intrusion. These occurrences are not so much related to the functions of the wetlands as they are to fluctuations, seasonal and long-term, in weather and climate variations.

Floodflow alteration can be considered a significant function in coastal wetlands such as where extensive salt marshes or dunes provide buffers to storm surges. The narrow and discontinuous marsh fringes along North Mill Pond provide negligible protection against storm surges, and constructed barriers such as riprap banks and retaining walls are the principal features providing such protection in the vicinity of Maplewood Avenue.

Potential for educational/scientific value associated with North Mill Pond at this site is limited by the minimal controlled public access to the Pond and adjacent wetlands. A sidewalk along both sides of Maplewood Avenue permits visual access, but physical access is obstructed by retaining walls, steep slopes, and adjacent private property. In general, the potential for limited use of the site as an “outdoor classroom” is present, and the educational opportunity provided by the view of the Pond and adjacent developed land is intriguing, but this value is deemed negligible due to access issues including limited parking and safety issues related to vehicular traffic.

Uniqueness/heritage value was determined to be negligible for this location. Although the area was developed during early colonial times, no historic or archaeological interests associated with the Pond or adjacent wetlands were observed at this location.

Endangered species habitat is a potential value of wetlands. A New Hampshire Natural Heritage Bureau preliminary online datacheck for this location was performed to assess the potential for the presence of threatened or endangered species in the vicinity. This preliminary datacheck resulted in a finding of no

TES Environmental Consultants, LLC

known occurrences of threatened or endangered species or exemplary natural communities in the vicinity of the project. Such datachecks consist of reviews of all known occurrences of such species or communities within one mile of a proposed project, and is subject to change over time as new occurrences are recorded. A complete review of this matter will be required during the New Hampshire wetland permitting process for this project, although it is considered unlikely that the proposed culvert replacement would be found to have an adverse impact on any such sensitive species or habitats.

In general, the proposed project to replace the culvert at Maplewood Avenue over North Mill Pond would not be expected to cause any degradation of the functions and values associated with the Pond and the adjacent wetlands. Continued unrestricted passage of flows, sediment, and movement of fish and wildlife through the area will continue as under the present conditions. With the implementation of best management construction practices, the project would avoid potential construction-phase impacts related to sedimentation and erosion.

Please feel free to contact me with any questions or comments regarding this report.

Sincerely,

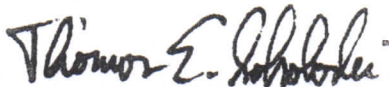

Thomas E. Sokoloski
New Hampshire Certified Wetland Scientist #127

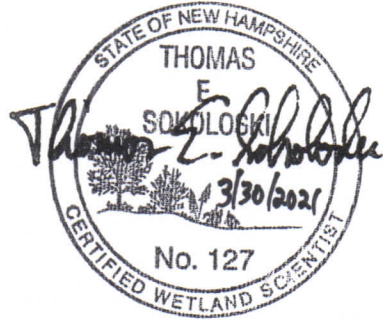

Wetland Function-Value Evaluation Form

Total area of wetland ^{+/-} 0.0000 acres Human made? No Is wetland part of a wildlife corridor? No or a "habitat island"? No
 Adjacent land use Residential, Commercial, Industrial Distance to nearest roadway or other development 0 feet
 Dominant wetland systems present Estuarine Contiguous undeveloped buffer zone present No
 Is the wetland a separate hydraulic system? No If not, where does the wetland lie in the drainage basin? Tidal

How many tributaries contribute to the wetland? 1 Wildlife & vegetation diversity/abundance (see attached list)
(Hodgson Brook)

Wetland I.D. North Mill Pond
 Latitude 43.0797 Longitude 70.7655
 Prepared by: TPS Date 3/27/2021
 Wetland Impact: Type TBD Area TBD

Evaluation based on: Field
 Corps manual wetland delineation completed? Y N (OTW)

Function/Value	Occurrence Y N	Rationale (Reference #)*	Principal Function(s)/Value(s)	Comments
Groundwater Recharge/Discharge	<input checked="" type="checkbox"/>			Absent - tidal resource.
Floodflow Alteration	<input checked="" type="checkbox"/>			North Mill Pond has limited flood storage/desynchronization.
Fish and Shellfish Habitat	<input checked="" type="checkbox"/>	1,4		Limited known potential; no shellfish beds (WPPP)
Sediment/Toxicant Retention	<input checked="" type="checkbox"/>	1,2,3,4,8,9	<input checked="" type="checkbox"/>	Opportunity present; sediments provide toxicant retention.
Nutrient Removal	<input checked="" type="checkbox"/>	1,2,3,4,6,7	<input checked="" type="checkbox"/>	Sediment binding potential; minimal vegetative uptake.
Production Export	<input checked="" type="checkbox"/>			Limited vegetative production present in Pond overall.
Sediment/Shoreline Stabilization	<input checked="" type="checkbox"/>	1,2,3,10,11	<input checked="" type="checkbox"/>	Much of shoreline at road stabilized by riprap walls.
Wildlife Habitat	<input checked="" type="checkbox"/>	6,12,18		Modest habitat due to minimal vegetation and development.
Recreation	<input checked="" type="checkbox"/>	7,9		Limited accessibility and interest on Pond itself.
Educational Scientific Value	<input checked="" type="checkbox"/>			Generally inaccessible to public; high disturbance.
Uniqueness/Heritage	<input checked="" type="checkbox"/>	1,3,13,14,17		No observed unique/significant historic features.
Visual Quality/Aesthetics	<input checked="" type="checkbox"/>	2,6,12	<input checked="" type="checkbox"/>	Open water, mud flats, viewed from road.
Endangered Species Habitat	<input checked="" type="checkbox"/>			Preliminary NH NHB data check - negative results.
Other				

* Refer to back up list of numbered considerations.

TES

TES ENVIRONMENTAL CONSULTANTS, L.L.C.



FIGURE 1
Arch Culvert at Maplewood Avenue Over North Mill Pond, Portsmouth, View
Southwest of Seaward Side of Culvert from Shoreline (2/28/2020)

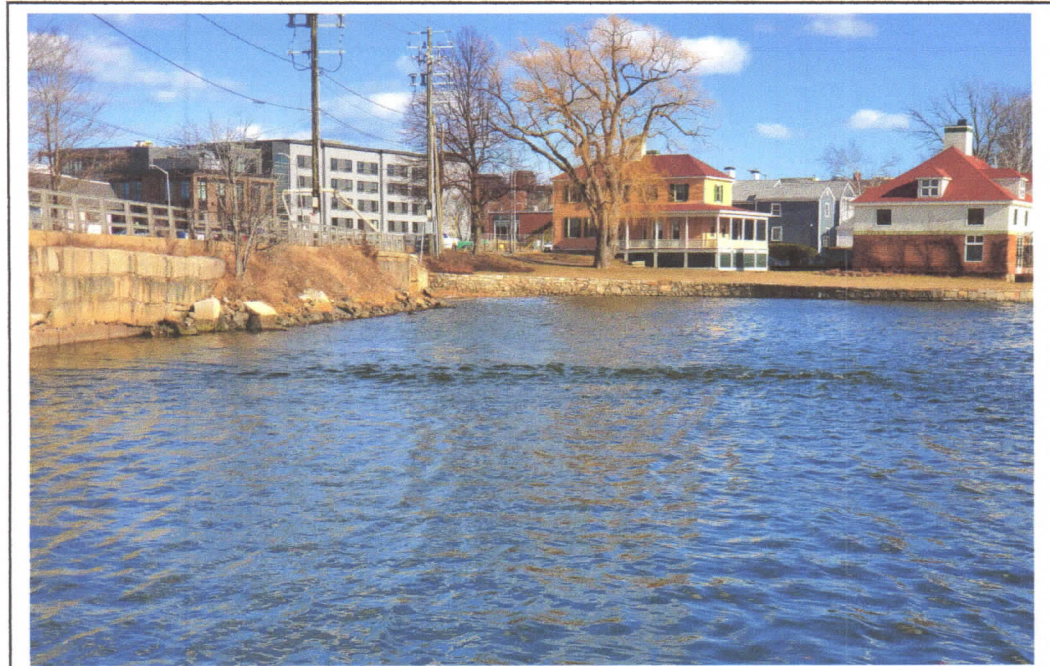

FIGURE 2
Residential and Commercial/Industrial Development on East Side of Project
Site, View East from Western Shoreline of North Mill Pond (2/28/2020)

Environmental Planning & Permitting

Soil & Wetland Investigations

TES

TES ENVIRONMENTAL CONSULTANTS, L.L.C.



FIGURE 3
North Mill Pond, Landward Side, View Southeast from West Side of Culvert
in Maplewood Road, Mid-Incoming Tide (2/28/2020)

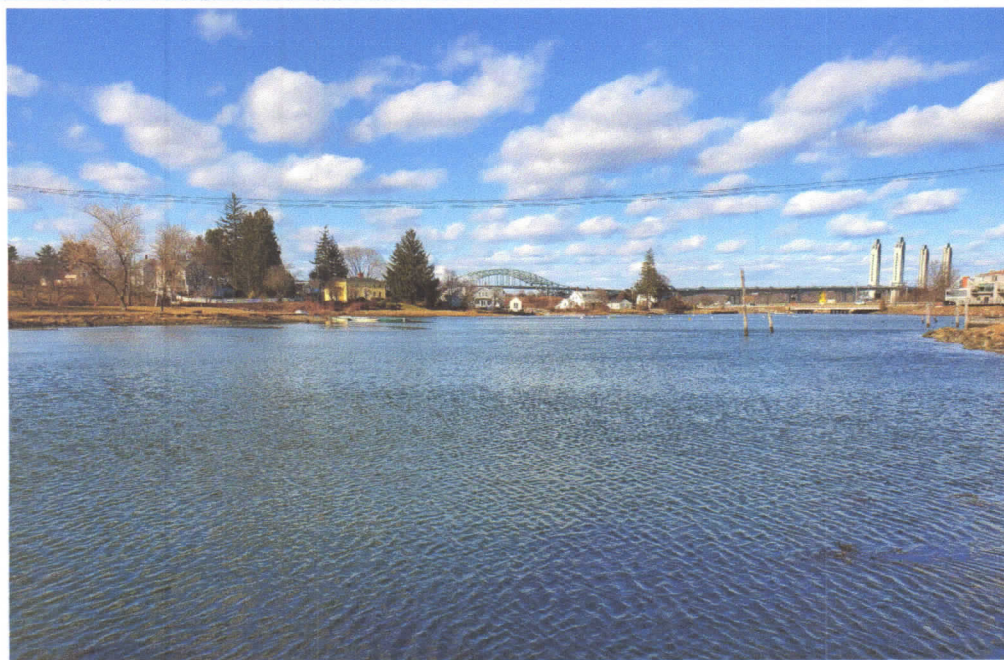

FIGURE 4
North Mill Pond, Seaward Side, View North from East Side of Culvert in
Maplewood Road, Mid-Incoming Tide (2/28/2020)

Environmental Planning & Permitting

Soil & Wetland Investigations



FIGURE 5

Rockweed Growing on Stones and Riprap in the Subtidal and Lower Intertidal Areas Near the Maplewood Avenue Culvert Site (2/28/2020)

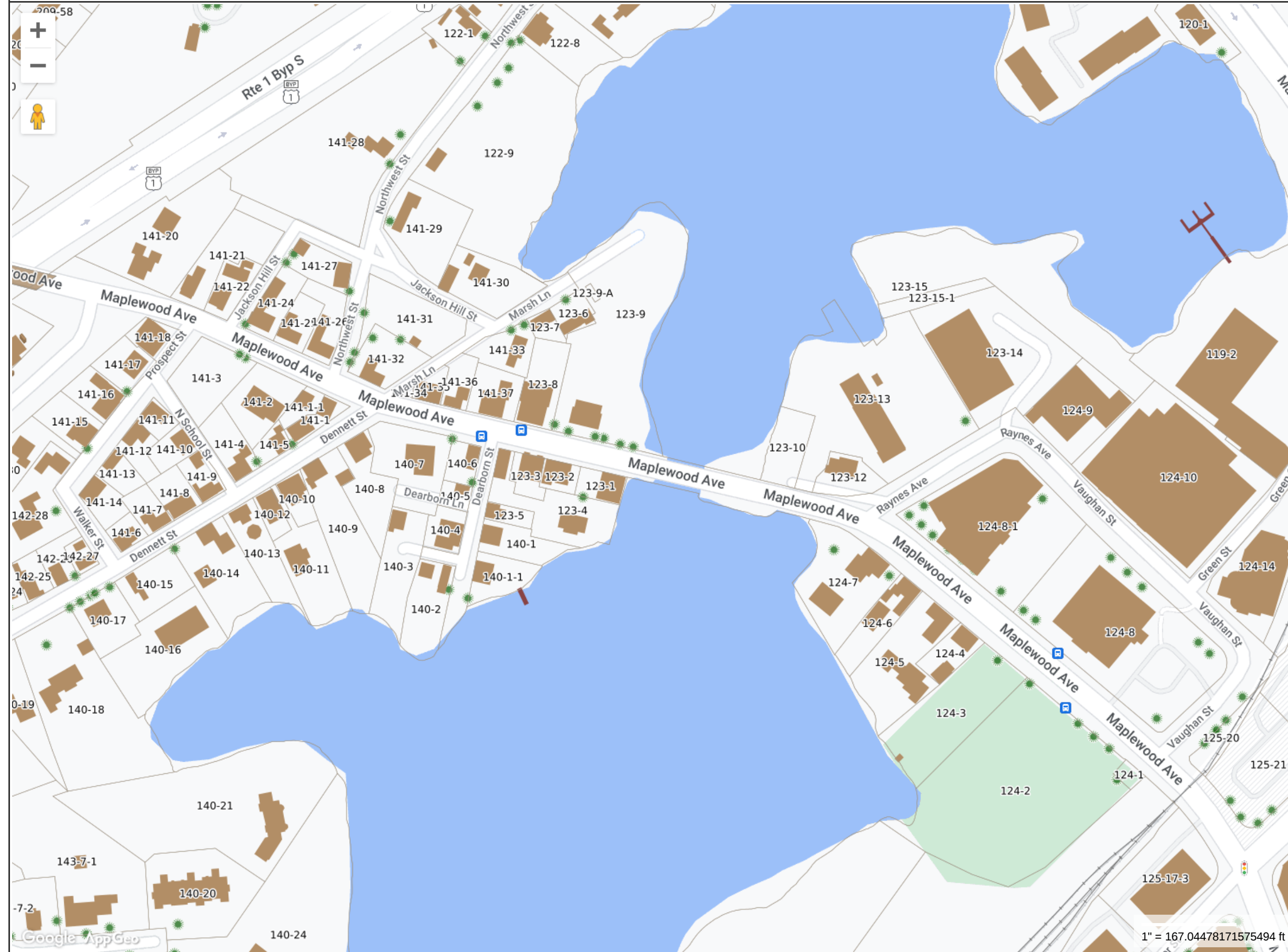

FIGURE 6

Remnants of Salt Marsh Cordgrass Growing within the Intertidal Zone Near the Maplewood Avenue Culvert Site (2/28/2020)

Tax Map

Tax Map - Rehabilitation of the Maplewood Avenue Bridge, Portsmouth, NH



**MAP FOR REFERENCE ONLY
NOT A LEGAL DOCUMENT**

City of Portsmouth, NH makes no claims and no warranties, expressed or implied, concerning the validity or accuracy of the GIS data presented on this map.

Geometry updated 09/21/2022
Data updated 3/9/2022

Print map scale is approximate. Critical layout or measurement activities should not be done using this resource.

1" = 167.04478171575494 ft

Abutters List

Abutters List
New Hampshire Department of Environmental Services
WETLAND PERMIT APPLICATION

Repair of the Maplewood Avenue Bridge over North Mill Pond, Portsmouth, NH

Map/Lot	Owner	Property Address	Mailing Address
123/9	Jackson Point LLC	235 Maplewood Avenue Portsmouth, NH 03801	P.O. Box 1131 Rye, NH 03780
123/1	230 Maplewood Ave LLC	230 Maplewood Avenue Portsmouth, NH 03801	30 Spring Street Portsmouth, NH 03801
123/4	Regan Electric Co. Inc.	6 Dearborn Street Portsmouth, NH 03801	94 Langdon Street Portsmouth, NH 03801
123/10	31 Raynes LLC C/O Portsmouth Chevrolet	Maplewood Avenue Portsmouth, NH 03801	549 Route 1 Bypass Portsmouth, NH 03801
124/7-1 124/7-2	Gideon Walker House Trust James H. Somes Jr., Trustee	154 A Maplewood Avenue Portsmouth, NH 03801 154 B Maplewood Avenue Portsmouth, NH 03801	154 Maplewood Avenue Portsmouth, NH 03801

Sample Notice to Abutters

VIA CERTIFIED MAIL

August XX, 2023

Abutter's Name
Mailing Address
City, State, Zip Code

Re: Wetlands Permit Application
Repair of the Maplewood Avenue Bridge over North Mill Pond, Portsmouth, NH
Hoyle, Tanner Project No. 20.905110
Abutter Map X/Lot X

The City of Portsmouth will be submitting an application for a Wetlands Permit from the New Hampshire Department of Environmental Services (NHDES) Wetlands Bureau for the proposed repairs to the Maplewood Avenue Bridge (NHDOT Bridge No. 231/103) over North Mill Pond. Under state law RSA 482-A:3 I (d)(1), we are required to notify you about the application, which proposes work abutting your property.

The City of Portsmouth is proposing to rehabilitate the grouted corrugated metal plate arch (CMPA) liner that was installed in 1976 as part of a previous rehabilitation project. The existing crossing is in serious condition and is included on the NHDOT Municipal Red List. The repair project consists of installation of a spray-applied geopolymer liner to the inside surface of the metal culvert liner to restore structural integrity. In addition, sections of the retaining wall supporting Maplewood Avenue will be reconstructed or stabilized with reuse of the existing stone. Supplemental riprap will be reinstalled along areas of the north side inlet to protect the restored retaining walls from future tidal impacts. Drainage system improvements, roadway reconstruction, and rail support slab replacement will mitigate the existing roadway settlement, ponding, and sidewalk rotation. Traffic will be managed by a combination of alternating 1 way traffic through the site and portions of complete shutdown with a detour.

A copy of the wetlands permit application, including the proposed plans, will be available for viewing in the near future at Portsmouth City Hall during normal business hours or at the NHDES offices by scheduling a file review by calling (603) 271-2919.

Sincerely,
Hoyle, Tanner & Associates, Inc.

Kimberly R. Peace
Senior Environmental Coordinator

**Documentation of Applicant's Legal
Interest - Easement**

Unofficial Document Unofficial Document

EASEMENT DEED

KNOW ALL MEN BY THESE PRESENTS, that 235 Maplewood Avenue LLC, 1116 Ocean Boulevard, Rye, County of Rockingham and State of New Hampshire, grants to the City of Portsmouth, 1 Junkins Avenue, Portsmouth, County of Rockingham and State of New Hampshire,

with quitclaim covenants,

A permanent easement over the following described property consisting of all the right, title and interest necessary for the development, maintenance and operation of the property for those uses determined to be in the public interest by the City Council of the City of Portsmouth. The interest conveyed hereby includes, but is not limited to, the right to develop, operate and maintain the property as a public park and the authority to adopt ordinances, rules and regulations with respect to the property to the same extent which the City may take such actions concerning property which it holds in fee title.

Responsibility for any environmental conditions existing as of the date of execution of this easement remain with the Grantor and its successors in title.

The premises over which this easement is granted are located at 235 Maplewood Avenue, Portsmouth, New Hampshire, and more fully described as follows:

Beginning at an iron rod set in the northerly sideline of Maplewood Avenue at a point which is 100 feet easterly from the southwesterly premises of the property of the grantor; thence running N 00° 38' 25" E 143.95 feet to an iron rod set; thence turning and running N 72° 40' 47" W 69.62 feet to an iron rod set, both bounds being by other land of the grantor; thence turning and running N 60° 05' 52" E by and along property now or formerly of Walter G. Ziebarth 68.38 feet to an iron rod set; thence turning and running N 31° 26' 50" W 72.26 feet to a point; thence turning and running S 58° 33' 10" W 10.00 feet; thence turning and running N 31° 26' 50" W 39± feet to the mean high water mark of the North Mill Pond; thence turning and running along the North Mill Pond 642± feet to a point in the northerly sideline of Maplewood Avenue; thence turning and running along the northerly sideline of Maplewood Avenue N 77° 15' 10" W 80± feet to the point of beginning.

Being a portion of the same premises conveyed to the grantor by deed of Joseph G. Sawtelle, Trustee of Dearborn Place Trust and Brian Nickerson, as Trustee of Laurel Development Trust dated December 31, 1996, and recorded in the Rockingham County Registry of Deeds at Book 3194, Page 1878, and being as shown on Easement Plan, Map 123, Lot 9, 235 Maplewood Avenue LLC to the City of Portsmouth, 235 Maplewood Avenue, Portsmouth, N.H., September, 2000.

ROCKINGHAM COUNTY
REGISTRY OF DEEDS

030350

2001 MAY -4 PM 12:37

Unofficial Document Unofficial Document

Unofficial Document Unofficial Document

235 Maplewood Avenue LLC

Dated: April 18, 2001

By: Caryl J. Sawtelle
Its ManagerSTATE OF NEW HAMPSHIRE
ROCKINGHAM, SS.

Personally appeared Caryl J. Sawtelle, Manager of 235 Maplewood Avenue LLC, a New Hampshire Limited Liability Company known to me, or satisfactorily proven, to be the person whose name is subscribed to the foregoing instrument and acknowledged that he/she executed the same for the purposes therein contained,

Before me,

Janet M. LeTarte
~~Justice of the Peace/Notary Public~~

JANET M. LeTARTE
Notary Public
My Commission Expires
May 22, 2001

Unofficial Document Unofficial Document

In accepting the foregoing easement, the City of Portsmouth agrees to indemnify the grantor from any losses for claims of third parties using the easement unless based on the negligence of the grantor.

City of Portsmouth

Dated: MAY 4, 2001

By: J.P.B.
Its Authorized Officer
Pursuant to vote of the City Council on
March 12, 2001.

STATE OF NEW HAMPSHIRE
ROCKINGHAM, SS.

Personally appeared John P. Bohonko, authorized to accept said easement for the City of Portsmouth, known to me, or satisfactorily proven, to be the person whose name is subscribed to the foregoing instrument and acknowledged that he/she executed the same for the purposes therein contained,

Before me,

Robert Sullivan
Justice of the Peace/Notary Public
Robert Sullivan

Unofficial Document Unofficial Document Unofficial Document

NHDOT Specifications Section 583
Riprap

SECTION 583 -- RIPRAP**Description**

1.1 This work shall consist of furnishing and placing riprap as shown on the plans or ordered. Riprap is typically required for erosion protection of bridge structures in waterways, for active waterway channel slopes and bottoms, and for intermittent waterway channels where the Engineer determines riprap protection is required to resist expected high water flow velocities.

Materials

2.1 Riprap shall be quarry stone of approved quality, hard, durable, sub-angular to angular in shape, resistant to weathering and free from structural defects such as weak seams and cracks.

2.1.1 The suitable shape of the individual stones shall be angular, meeting the gradation in 2.1.1.2 to create interlocking riprap to provide stability of the slope or channel. Round, thin and platy, elongated or needle-like shapes shall not be used.

2.1.1.1 The suitable riprap stone shape is determined by the Length to Thickness ratio, where Length is the longest dimension and Thickness is the shortest dimension, measured in perpendicular axes to each other. The suitable riprap stone shape shall have a length to thickness ratio of no greater than 3.

2.1.1.2 The gradation requirements of the riprap classes in Table 583-1 are based on the stone size Width, the largest dimension perpendicular to the Length and Thickness, and the distribution of stone sizes by volume. The volume distribution requires that 15 percent of the stone in the mass shall be no larger than the volume shown in the table (< 15% column), and 15 percent of the stone in the mass shall be no smaller than the volume shown in the table (> 85% column). The remaining 70 percent of the stone in the mass shall have a volume between these requirements, averaging to the volume shown in the table (15% - 85% column). None of the stones in the mass shall exceed the maximum volume shown in the table (Maximum column).

Table 583-1

Riprap Classes and Sizes			Percentage Distribution of Particle Sizes by Volume (cubic feet)			
Class	Nominal Size (in)	Maximum Size (in)	< 15%	15% – 85%	> 85%	Maximum
I	6	12	0.05	0.14	0.31	1.0
III	12	24	0.4	1.0	2.5	6.5
V	18	36	1.3	3.5	8.5	22
VII	24	48	3	8	19	53
IX	36	72	10	27	65	179

Note: Nominal Size and Maximum Size are based on the Width dimension of the stone. The riprap classes conform to the standard classes described in the FHWA HEC-23 publication.

2.1.2 The sources from which the stone is obtained shall be selected well in advance of the time when the material will be required in the field. The acceptability of the riprap stone shape and grading will be determined by the Engineer.

2.1.3 Control of the gradation will be completed by visual inspection approval by the Engineer of a stockpile at the quarry or other agreed site. Mechanical equipment as needed to assist in checking the stockpile gradation shall be provided by the Contractor. Stockpile replenishment will require re-approval.

2.2 Gravel blanket material shall conform to [209.2.1.2](#).

2.3 Geotextile shall conform to [593.2](#).

Construction Requirements

3.1 Preparation of slopes. Slopes that will be covered by riprap shall be free of brush, trees, stumps, and other organic material and shall be graded to a smooth surface. All soft material shall be removed to the depth shown on the plans or as directed and replaced with approved material per 203.3.6. It is the Contractor's responsibility to protect embankments and excavated slopes from erosion during construction of the riprap covered slope.

3.2 Gravel blanket construction. When called for on the plans, the gravel blanket shall be placed on the prepared area to the specified thickness in one operation, using methods which will not cause segregation of particle sizes within the layer. The surface of the finished layer shall be even and free from mounds or windrows.

3.3 Geotextile placement. Geotextile shall be placed in accordance with [593.3](#).

3.4 Riprap placement. Riprap shall be constructed to the dimensions shown on the plans or as directed by the Engineer.

3.4.1 Placement of riprap shall be conducted as soon as possible after gravel blanket or geotextile placement.

3.4.2 Placement of the riprap shall be started at the toe (key trench) and progress up the slope. The key trench at the bottom of the riprap shall be constructed as shown on the plans. If bedrock is encountered at the key trench it shall be brought to the attention of the Engineer to determine if modification to the riprap installation is needed.

3.4.3 Riprap shall be placed over geotextile by methods that do not stretch, tear, puncture or reposition the fabric. Riprap smaller than 1.5 cu. ft. in volume shall be placed with drop heights of less than 3 ft. to the placement surface. Riprap greater than 1.5 cu. ft. in volume shall be placed with no free fall height.

3.4.4 Equipment such as a clamshell, orange-peel bucket, skip or hydraulic excavator shall be used to place the riprap so it is well distributed and there are no large accumulations of either the larger or smaller sizes of stone. Dump trucks or front-end loaders tracked or wheeled vehicles shall not be used since they can destroy the interlocking integrity of the stone when driven over previously placed riprap. Placing the riprap by end dumping on the slopes will cause segregation and will not be permitted.

3.4.5 The riprap shall be placed in a manner which produces a well-graded mass. The larger stones shall be well distributed and the entire mass of riprap shall conform approximately to the gradation specified. Hand placing or rearranging of individual stones by mechanical equipment may be required to the extent necessary to secure the uniformity of gradation and surface specified. Fill voids between larger stones with small stones to ensure interlocking between the riprap.

3.4.6 After the riprap is in place, it shall be compacted by impacting (ramming) the exposed surface to produce a tight, locked surface, not varying more than 6" from the elevations shown on the plans.

3.4.7 Riprap placed in water requires close observation and increased quality control to ensure the required thickness, gradation and coverage is achieved.

Method of Measurement

4.1 Riprap will be measured by the cubic yard.

4.1.1 If the Engineer determines that in-place measurement is impracticable, the quantity for payment will be determined by loose measure in the hauling vehicle on the basis that 1 cubic yard vehicle measure is equivalent to 0.7 cubic yard in place.

Basis of Payment

5.1 The accepted quantity of riprap will be paid for at the Contract unit price per cubic yard (cubic meter) complete in place.

5.1.1 Only when the stone is examined in accordance with 2.1 and examination proves the gradation to be acceptable will payment be made as provided in [109.04](#).

5.1.2 Gravel blanket material specified or ordered will be paid for under [Section 209](#).

5.1.3 Geotextile specified or ordered will be paid for under [Section 593](#).

5.1.4 The accepted quantity of excavation required for placing riprap and for placing any underlying gravel blanket will be paid for under the item of excavation being performed. Excavation above refers only to excavation of original ground or to material ordered removed not shown on the plans.

5.1.5 Free borrow will not be required to replace the accepted quantity of stone obtained from the excavation. However, when the plans do not call for borrow but the quantity of material removed from excavation for use under this item requires the Contractor to furnish borrow to complete the work, such borrow will be subsidiary.

5.1.6 Replacement slope material resulting from the requirements of 3.1 will be paid in accordance with [203.5.1.9](#).

Pay item and unit:

583.1	Riprap, Class I	Cubic Yard
583.3	Riprap, Class III	Cubic Yard
583.5	Riprap, Class V	Cubic Yard
583.7	Riprap, Class VII	Cubic Yard
583.9	Riprap, Class IX	Cubic Yard

Project Plans

CITY OF PORTSMOUTH ROCKINGHAM COUNTY NEW HAMPSHIRE



PLANS OF PROPOSED BRIDGE REPAIRS MAPLEWOOD AVENUE OVER NORTH MILL POND NHDOT BRIDGE NO. 231/103

AUGUST 2023



LOCATION MAP

INDEX OF SHEETS

SHEET NO. DESCRIPTION

- 1 TITLE SHEET
- 2 STANDARD SYMBOLS SHEET (1 OF 2)
- 3 STANDARD SYMBOLS SHEET (2 OF 2)
- * 4 PROJECT NOTES AND SUMMARY OF QUANTITIES
- 5 TYPICAL SECTIONS
- * 6 CONSTRUCTION ACCESS PLAN
- * 7 TRAFFIC CONTROL PLAN
- 8 SITE PLAN
- * 9 UTILITY RELOCATION PLAN
- 10 WETLAND IMPACTS PLAN
- 11 WATER DIVERSION PLAN
- 12 BRIDGE REPAIR DETAILS
- * 13 RAIL AND SUPPORT SLAB JOINT LAYOUT PLAN
- 14 RAIL SUPPORT SLAB CONSTRUCTION DETAILS (1 OF 2)
- 15 RAIL SUPPORT SLAB CONSTRUCTION DETAILS (2 OF 2)
- * 16 RETAINING WALL DETAILS
- * 17 CROSS SECTIONS (1 OF 2)
- * 18 CROSS SECTIONS (2 OF 2)
- * 19 RAIL DETAILS
- * 20 ROADWAY PROFILE

* INDICATES SHEETS NOT INCLUDED IN THIS SUBMISSION

REV.	DESCRIPTION	DATE

NHDOT BRIDGE NO.	DESIGNED	DRAWN	CHECKED	DATE
231/103	RPM	WCT/AG	AML	AUGUST 2023

HOYLE TANNER
Pease International Tradeport
100 International Drive, Suite 360
Portsmouth, NH 03801
(603) 431-2520 www.foyletanner.com

PORTSMOUTH, NEW HAMPSHIRE
MAPLEWOOD AVENUE OVER NORTH MILL POND
TITLE SHEET

PROJECT NO. 2090511000
SHEET NO.

1
SHEET 1 OF 20

DRAWING SIZES HAVE BEEN REDUCED
DO NOT SCALE, USE DIMENSIONS GIVEN

GENERAL

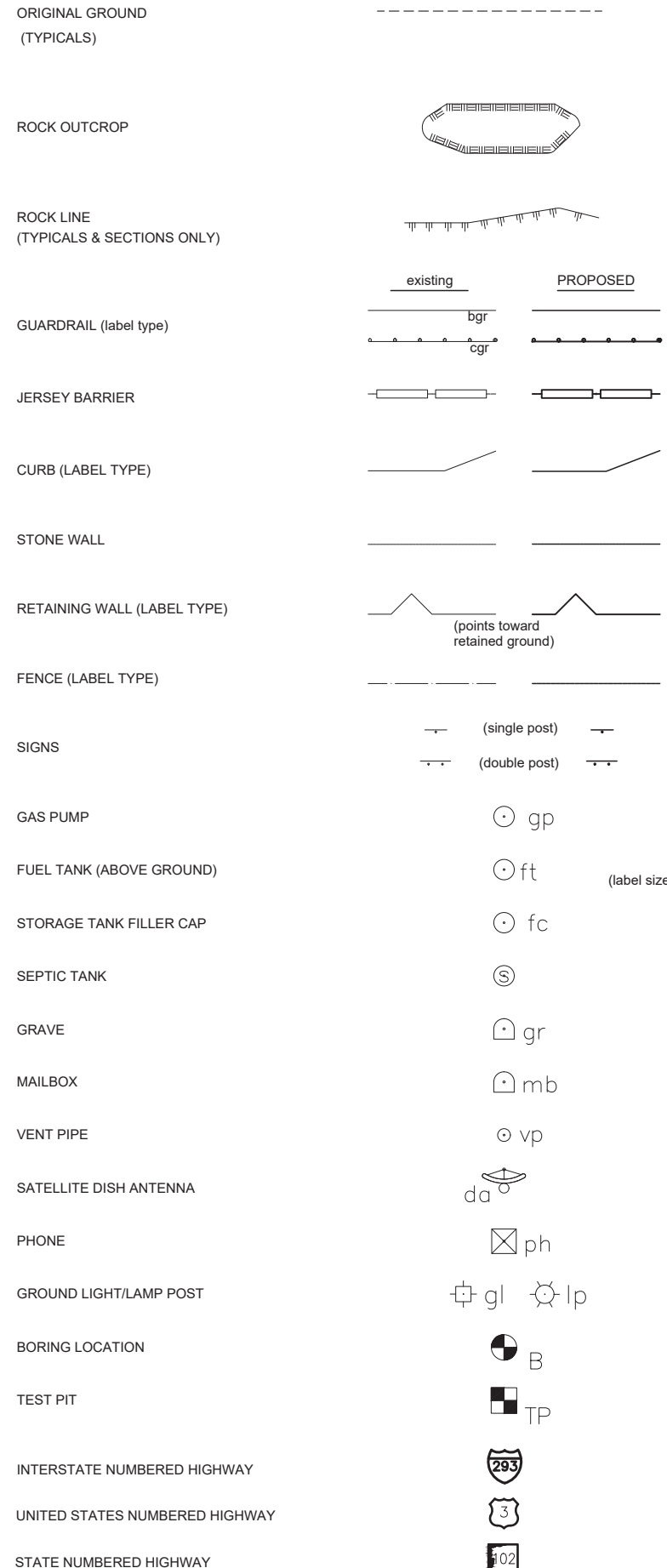
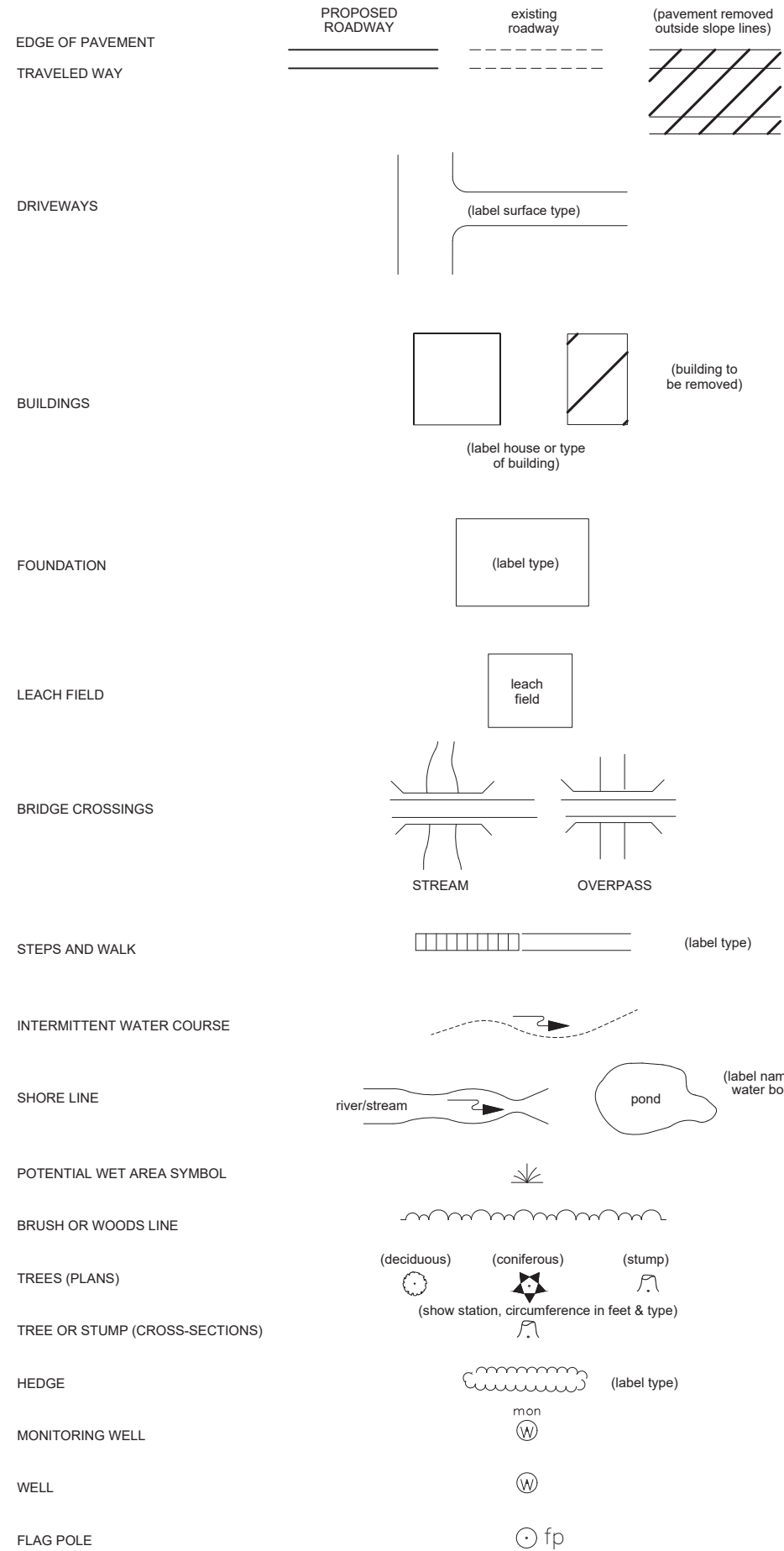

SHORELAND - WETLAND

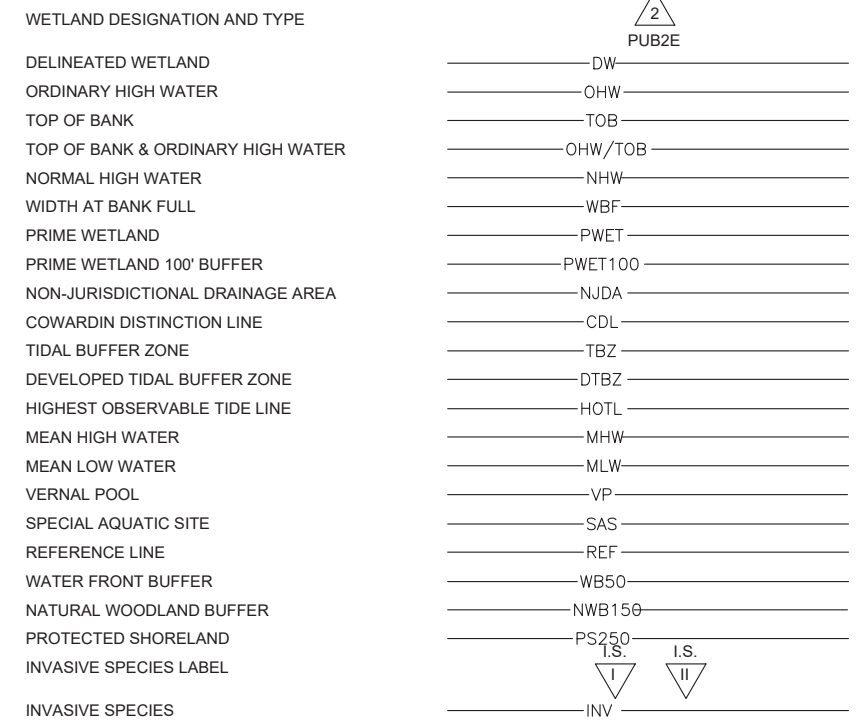

FLOODPLAIN / FLOODWAY

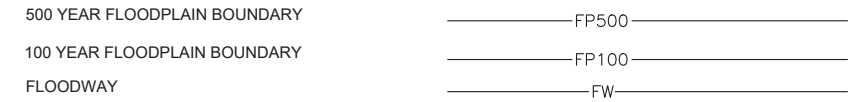

ENGINEERING

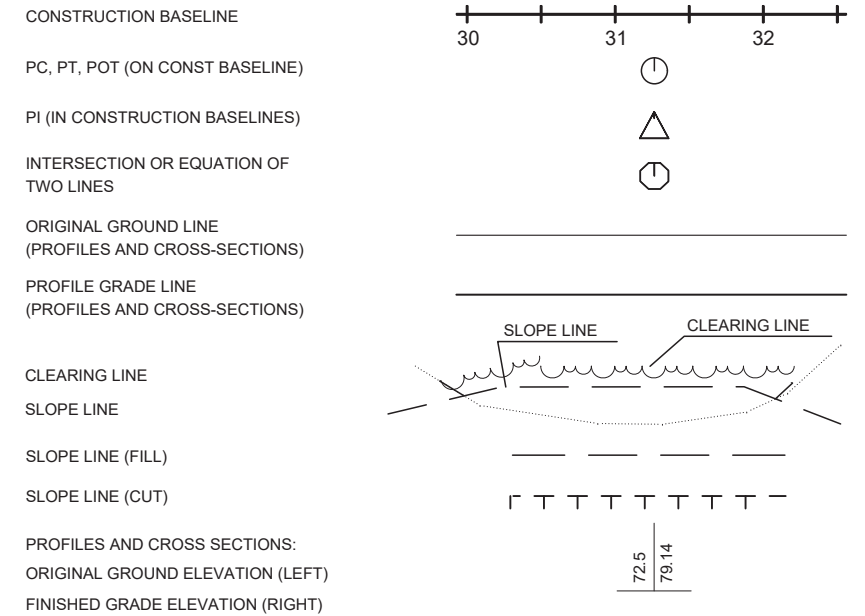

REV.	DESCRIPTION	DATE

HOYLE TANNER
 Pease International Tradeport
 100 International Drive, Suite 360
 Portsmouth, NH 03801
 (603) 431-2520 www.foyletanner.com

PORTSMOUTH, NEW HAMPSHIRE
 MAPLEWOOD AVENUE OVER NORTH MILL POND
 STANDARD SYMBOLS SHEET (1 OF 2)

PROJECT NO. 2090511000
 SHEET NO.

8/23/2023 4:35 PM C:\PROJECTS\Portsmouth-NH\20_005110_00-Maplewood-Avenue-Brigde-CADD\Cutsheets\2090511000Symbols.dwg

DRAINAGE

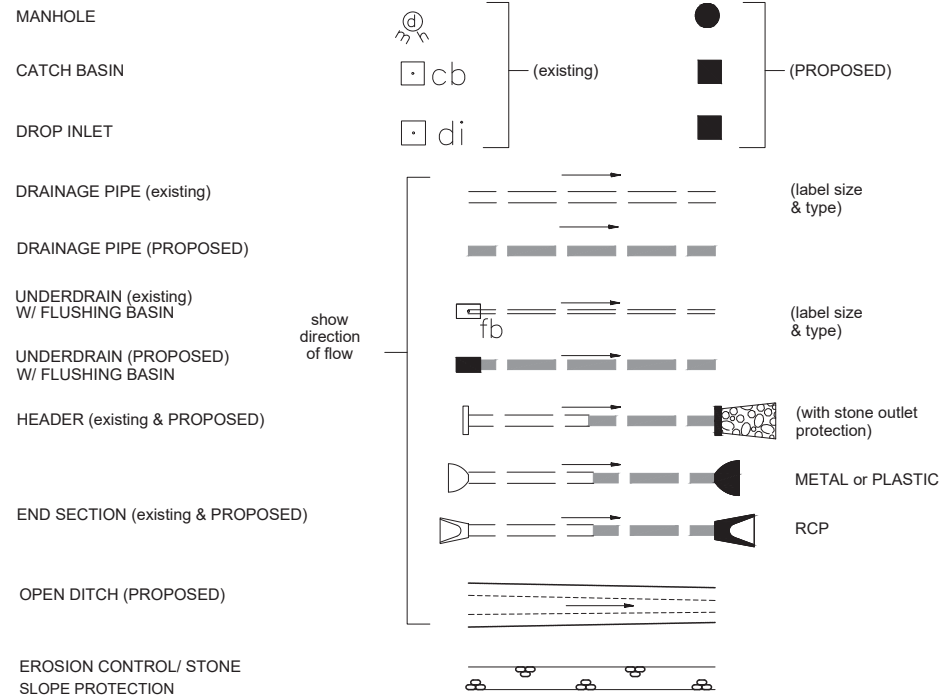

BOUNDARIES / RIGHT-OF-WAY

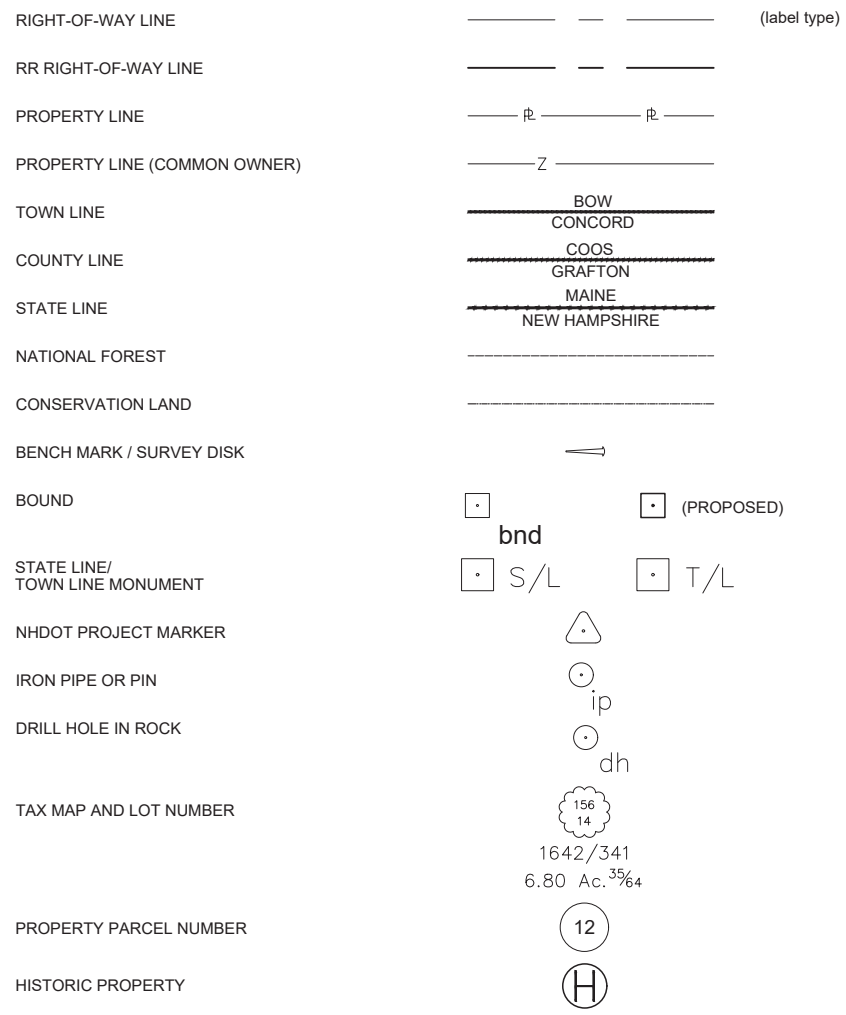

UTILITIES

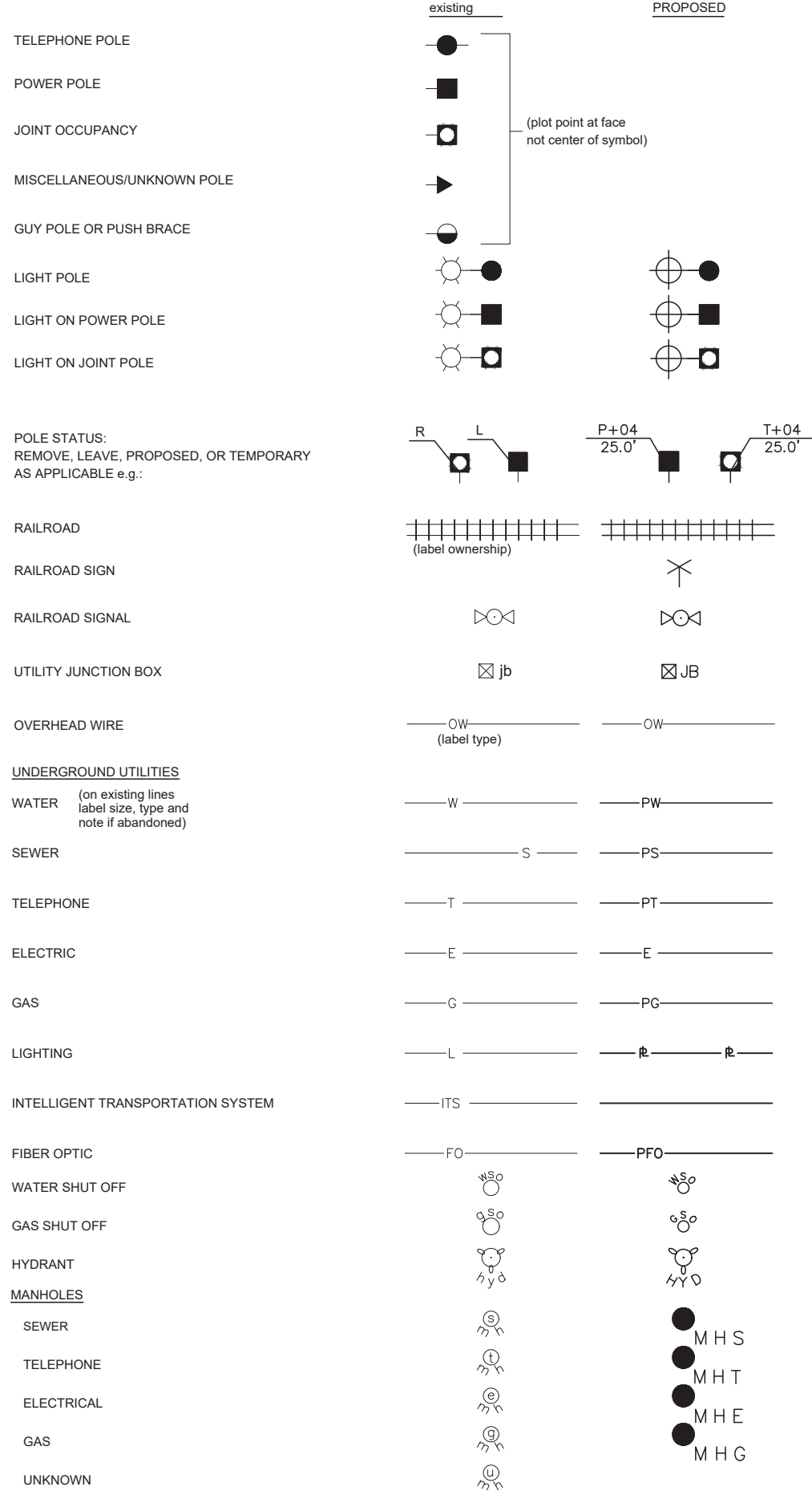

TRAFFIC SIGNALS / ITS

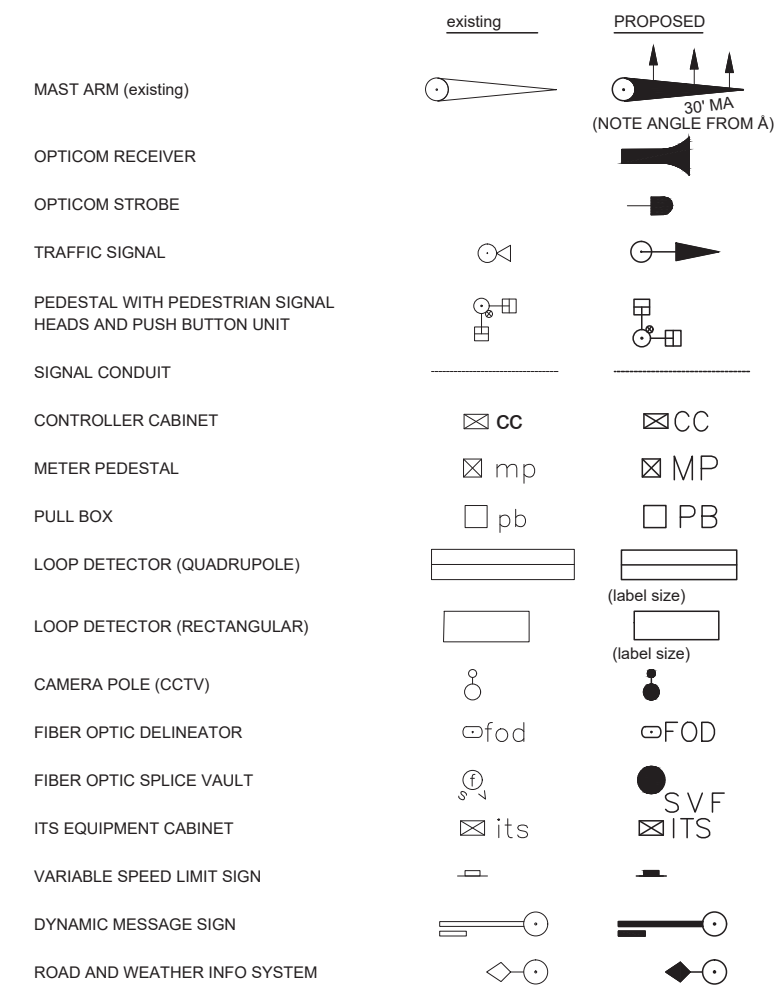

CONSTRUCTION NOTES

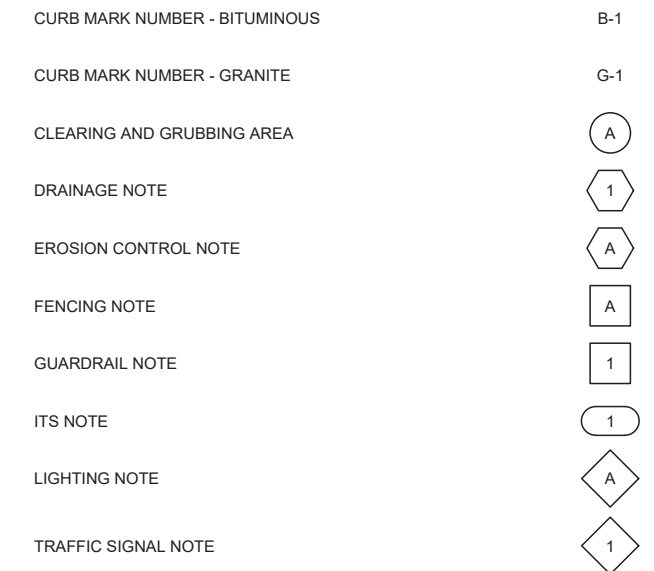

REV	DESCRIPTION	DATE

HOYLE TANNER
 Pease International Tradeport
 100 International Drive, Suite 360
 Portsmouth, NH 03801
 (603) 431-2520 www.foyletanner.com

PORTSMOUTH, NEW HAMPSHIRE
 MAPLEWOOD AVENUE OVER NORTH MILL POND
 STANDARD SYMBOLS SHEET (2 OF 2)

PROJECT NO. 2090511000
 SHEET NO.

8/23/2023 4:35 PM C:\PROJECTS\Portsmouth-NH-20_005110_00-Maplewood-Avenue-Bridge-CADD\Cutsheets\2090511000\symbols.dwg

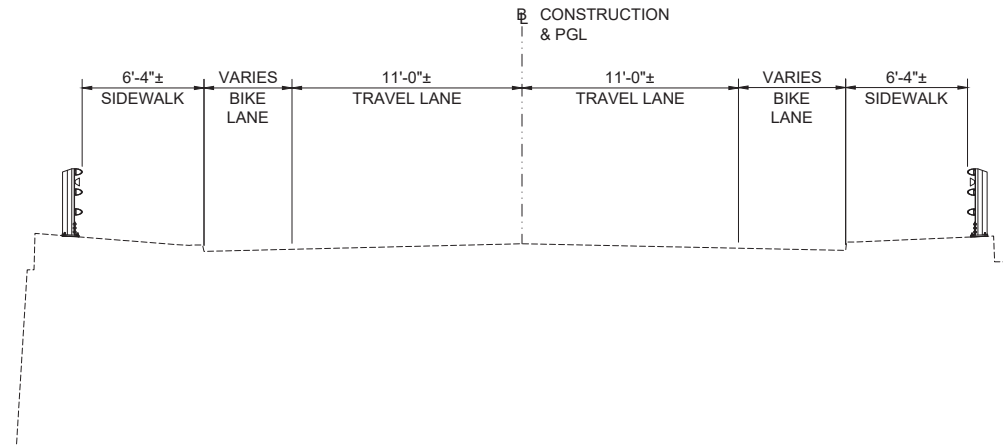

EXISTING TYPICAL SECTION
NOT TO SCALE

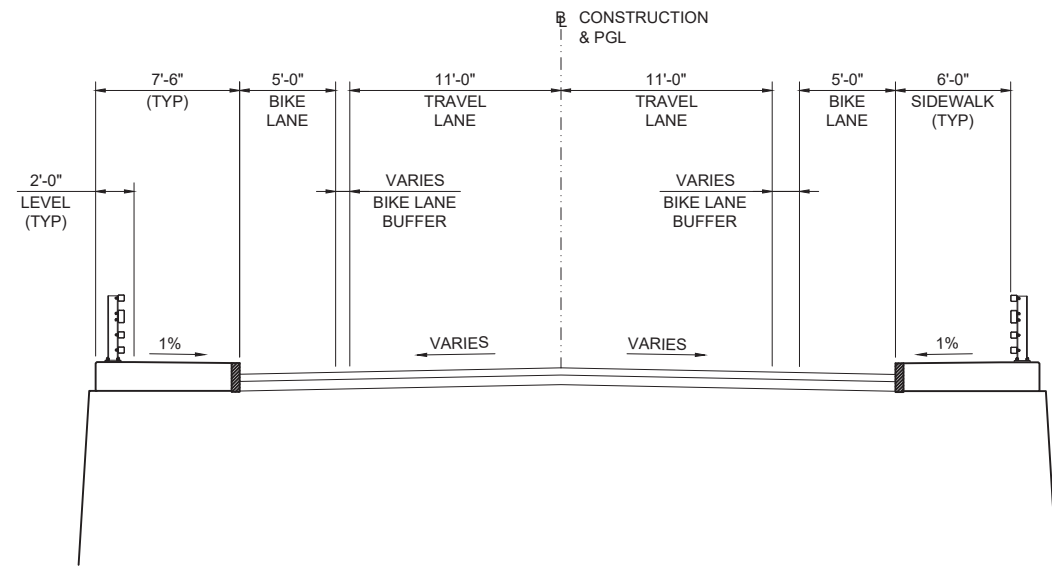

PROPOSED TYPICAL SECTION
NOT TO SCALE

REV.	DESCRIPTION	DATE

NH DOT BRIDGE NO.	231103
DESIGNED	RPM
DRAWN	TAG
CHECKED	AML
SCALE	AS SHOWN
DATE	AUGUST 2023

HOYLE TANNER
Pease International Tradeport
100 International Drive, Suite 360
Portsmouth, NH 03801
(603) 431-2320 www.foyletanner.com

PORTSMOUTH, NEW HAMPSHIRE
MAPLEWOOD AVENUE OVER NORTH MILL POND
TYPICAL SECTIONS

PROJECT NO. 2090511000
SHEET NO.

5
SHEET 5 OF 20

This document is prepared as an instrument of service and shall remain the property of Hoyle Tanner. It may not be used, reproduced, disseminated or transferred in any manner, including electronically, for any other purpose than this project, without the written permission of Hoyle Tanner.

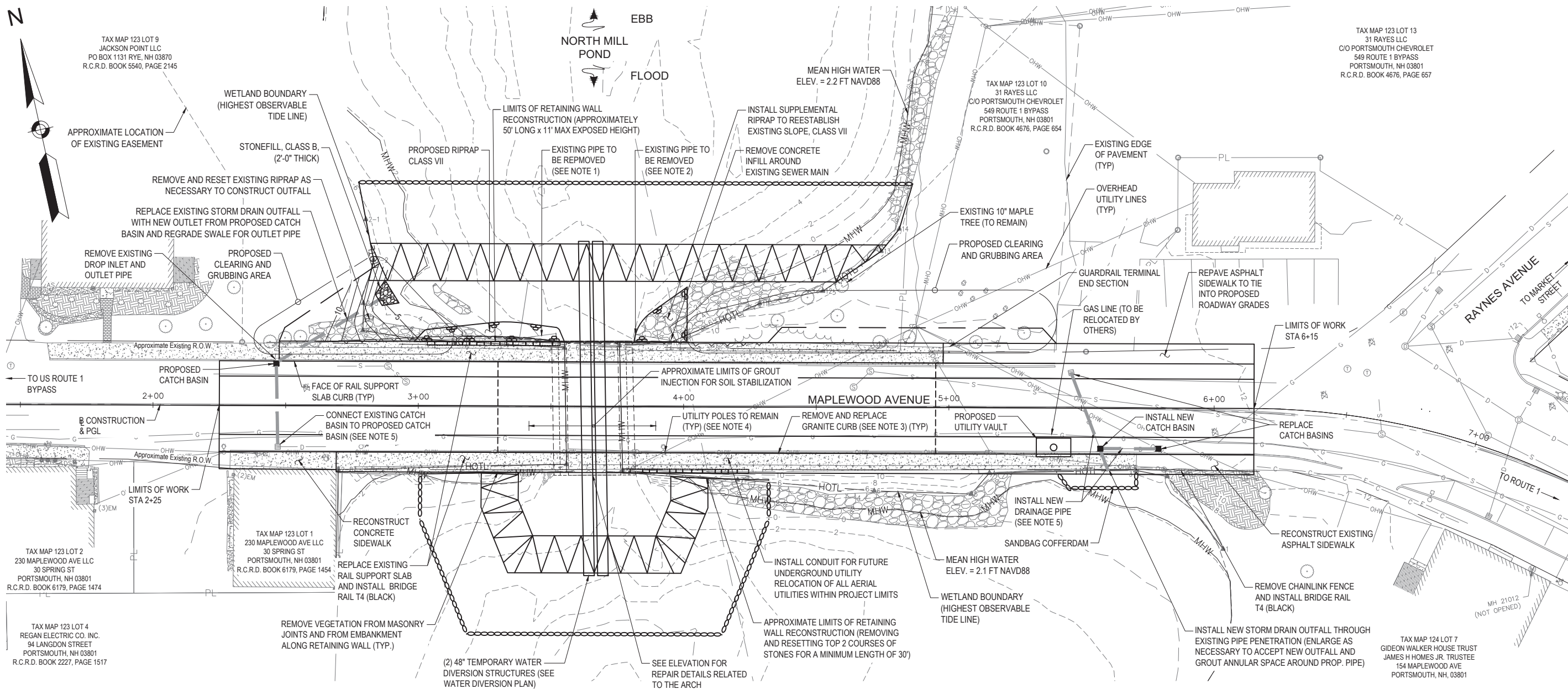

SITE PLAN

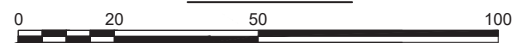

GENERAL ENVIRONMENTAL IMPACT NOTES

1. ALL MANUFACTURED EROSION AND SEDIMENT CONTROL PRODUCTS, WITH THE EXCEPTION OF TURF REINFORCEMENT MATS, UTILIZED FOR, BUT NOT LIMITED TO, SLOPE PROTECTION, RUNOFF DIVERSION, SLOPE INTERRUPTION, PERIMETER CONTROL, INLET PROTECTION, CHECK DAMS, AND SEDIMENT TRAPS SHALL NOT CONTAIN PLASTIC, OR MULTIFILAMENT OR MONOFILAMENT POLYPROPYLENE NETTING OR MESH WITH AN OPENING SIZE OF GREATER THAN 1/8 INCHES.
2. ALL OBSERVATIONS OF THREATENED OR ENDANGERED SPECIES ON THE PROJECT SITE SHALL BE REPORTED IMMEDIATELY TO THE NHFG NONGAME AND ENDANGERED WILDLIFE ENVIRONMENTAL REVIEW PROGRAM BY PHONE AT 603-271-2461 AND BY EMAIL AT NHFGREVIEW@WILDLIFE.NH.GOV, WITH THE EMAIL SUBJECT LINE CONTAINING THE NHB DATACHECK TOOL RESULTS LETTER ASSIGNED NUMBER (NHB22-1712), THE PROJECT NAME (MAPLEWOOD AVENUE OVER NORTH MILL POND), AND THE TERM "WILDLIFE SPECIES OBSERVATION".
3. PHOTOGRAPHS OF THE OBSERVED SPECIES AND NEARBY ELEMENTS OF HABITAT OR AREAS OF LAND DISTURBANCE SHALL BE PROVIDED TO NHFG IN DIGITAL FORMAT AT THE ABOVE EMAIL ADDRESS FOR VERIFICATION, AS FEASIBLE.
4. IN THE EVENT A THREATENED OR ENDANGERED SPECIES IS OBSERVED ON THE PROJECT SITE DURING THE TERM OF THE PERMIT, THE SPECIES SHALL NOT BE DISTURBED, HANDLED, OR HARMED IN ANY WAY PRIOR TO CONSULTATION WITH NHFG AND IMPLEMENTATION OF CORRECTIVE ACTIONS RECOMMENDED BY NHFG.
5. NHFG, INCLUDING ITS EMPLOYEES AND AUTHORIZED AGENTS, SHALL HAVE ACCESS TO THE PROPERTY DURING THE TERM OF THE PERMIT.

NOTES

1. SAWCUT AND REMOVE EX. ABANDONED SEWER MAIN AT THE LIMITS OF EXCAVATION NECESSARY FOR RETAINING WALL RECONSTRUCTION. REVIEW PORTION OF SEWER MAIN TO REMAIN WITH ENGINEER AND INSTALL FLOWABLE FILL INTO REMAINING ABANDONED SEWER PIPE AS DIRECTED.
2. TRIM PROJECTING PORTION OF EX. CMP LINER AND CONCRETE HEADER. FILL ANY VOIDS BETWEEN LINER AND MASONRY PRIOR TO INSTALLING GEOPOLYMER LINER. CREATE A SMOOTH RADIUS TRANSITION BETWEEN LINER AND VERTICAL MASONRY FACE.
3. NEW CURBING TO BE INSTALLED AS PART OF RAIL SUPPORT SLAB CONSTRUCTION
4. UTILITY POLES WITHIN LIMITS OF CONSTRUCTION WILL REMAIN IN PLACE. RAIL SUPPORT SLAB DESIGN TO ACCOMMODATE FUTURE REMOVAL OF UTILITY POLES AND RELOCATION OF EXISTING AERIAL UTILITY LINES TO UNDERGROUND CONDUITS.
5. CONDUCT FIELD REVIEW OF DRAIN PIPE GEOMETRY AND PERFORM VIDEO INSPECTION OF EXISTING PIPES (ITEM 603.0001) TO DETERMINE ORIGIN, PURPOSE, AND STATUS OF PIPES. VIDEO INSPECT AS NECESSARY EXISTING LATERAL PIPE PENETRATIONS AND/OR OUTLETS WITHIN THE LIMITS OF REHABILITATION. COORDINATE WITH ENGINEER REGARDING ABANDONMENT OR REMOVAL OF THESE PIPES.

REV.	DESCRIPTION	DATE

HOYLE TANNER
 Pease International Tradeport
 100 International Drive, Suite 360
 Portsmouth, NH 03801
 (603) 431-2320 www.foyletanner.com

PORTSMOUTH, NEW HAMPSHIRE
 MAPLEWOOD AVENUE OVER NORTH MILL POND
 SITE PLAN

PROJECT NO. 2090511000
 SHEET NO.

8

SHEET 8 OF 20

8/23/2023 4:35 PM C:\PROJECTS\Portsmouth-NH\20_905110_00-Maplewood-Avenue-Bridge\CADD\Cad\Drawings\2090511000\Site.dwg

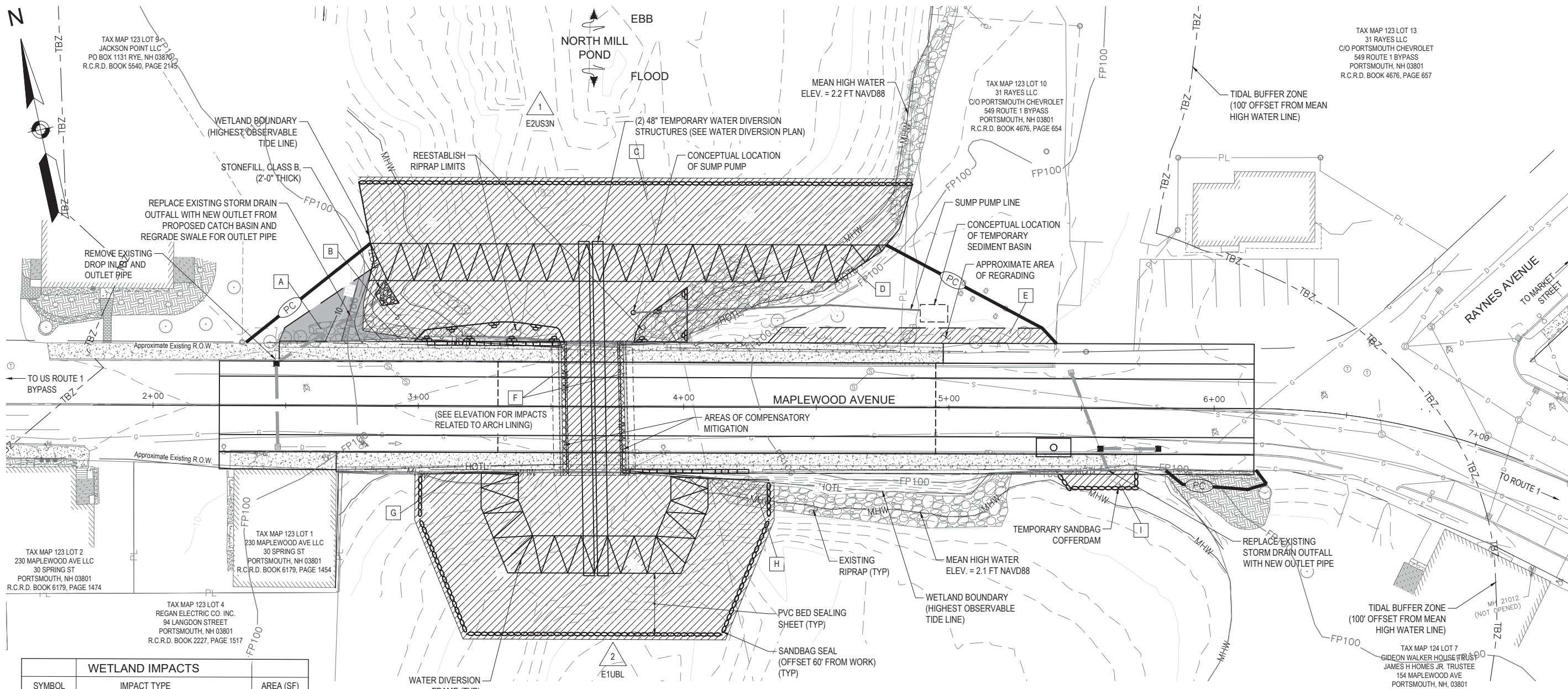

WETLAND IMPACTS		
SYMBOL	IMPACT TYPE	AREA (SF)
A	PERMANENT TBZ	499
B	TEMPORARY IMPACT BETWEEN MHW & HOTL	1140
C	TEMPORARY IMPACT BELOW MHW & HOTL	16943
D	TEMPORARY IMPACT BETWEEN MHW & HOTL	1048
E	TEMPORARY TBZ	596
F	PERMANENT IMPACT BELOW HOTL	38
F	PERMANENT IMPACT BELOW MHW	38
G	TEMPORARY IMPACT BETWEEN MHW & HOTL	117
H	TEMPORARY IMPACT BETWEEN MHW & HOTL	204
I	TEMPORARY TBZ	179

SUMMARY OF IMPACTS

TOTAL NEW TEMPORARY IMPACTS BELOW HOTL = 19452 SF
 TOTAL NEW PERMANENT IMPACTS BELOW HOTL = 38 SF
 TOTAL NEW TEMPORARY IMPACTS BELOW MHW = 16943 SF
 TOTAL NEW PERMANENT IMPACTS BELOW MHW = 38 SF
 TOTAL NEW TBZ TEMPORARY IMPACTS = 775 SF
 TOTAL NEW TBZ PERMANENT IMPACTS = 499 SF

TOTAL NHDES IMPACTS = 20764 SF
 TOTAL USACE IMPACTS = 16981 SF

TOTAL COMPENSATORY MITIGATION PROVIDED = * 206 SF

* TOTAL COMPENSATORY MITIGATION CUBIC AREA FOR FOOTING REMOVAL (SEE PROPOSED BRIDGE SECTION)
 LxWxH = 568 CF (L = 50'-6" (W = 2'-0 1/2") (H = 3'-7")

WETLAND CLASSIFICATION	
1 E2US3N	ESTUARINE, INTERTIDAL, UNCONSOLIDATED SHORE, MUD, REGULARLY FLOODED
2 E1UBL	ESTUARINE, SUBTIDAL, UNCONSOLIDATED BOTTOM, SUBTIDAL

THOMAS E. SOKOLOSKI, CERTIFIED WETLAND SCIENTIST #127 OF TES ENVIRONMENTAL CONSULTANTS, L.L.C. OF BOW, NH, PERFORMED THE WETLAND MAPPING ON FEBRUARY 28, 2020 ACCORDING TO THE STANDARDS OF THE CORPS OF ENGINEERS WETLAND DELINEATION MANUAL AND THE REGIONAL SUPPLEMENT TO THE CORPS OF ENGINEERS WETLAND DELINEATION MANUAL: NORTHCENTRAL AND NORTHEAST REGION, VERSION 2.0, JANUARY 2012, US ARMY CORPS OF ENGINEERS.

WETLAND IMPACTS PLAN

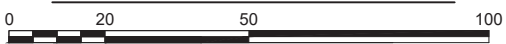

- LEGEND**
- TEMPORARY IMPACTS
 - PERMANENT IMPACTS
 - COMPENSATORY MITIGATION
 - HOTL — HIGHEST OBSERVABLE TIDE LINE (HOTL)
 - TBZ — TIDAL BUFFER ZONE (TBZ)
 - FP100 — EXISTING CONDITIONS 100 YEAR FLOOD PLAIN BOUNDARY
 - PC — SILT FENCE AND SILT SOCK
 - 1 E2US3N — WETLAND DESIGNATION NUMBER

GENERAL WETLAND IMPACTS NOTES

- AFTER COMPLETION OF IN-WATER WORK, REMOVE ALL WATER DIVERSION STRUCTURES AND RESTORE ALL DISTURBED AREAS TO PRE-CONSTRUCTION CONDITIONS.
- EROSION AND SEDIMENT CONTROL SHOWN FOR PLANNING PURPOSES ONLY. CONTRACTOR MEANS AND METHODS MAY ALTER SLIGHTLY BASED ON SITE CONDITIONS.
- CONTRACTOR SHALL RETAIN SEDIMENT ON-SITE AND IMPLEMENT THE FOLLOWING DEWATERING CONTROL PRACTICES:
 - TEMPORARY SEDIMENT BASINS SHALL BE SIZED TO RETAIN ON SITE, THE VOLUME OF A 2-YEAR 24-HOUR STORM EVENT FOR ANY AREA OF DISTURBANCE OR 3,600 CUBIC FEET OF STORMWATER RUNOFF PER ACRE OF DISTURBANCE, WHICHEVER IS GREATER.
 - CONSTRUCT AND STABILIZE DEWATERING INFILTRATION BASINS OR BAGS PRIOR TO ANY EXCAVATION THAT MAY REQUIRE DEWATERING.
 - TEMPORARY SEDIMENT BASINS SHALL BE PLACED AND STABILIZED AT LOCATIONS WHERE CONCENTRATED FLOWS (CHANNELS AND PIPES) CAN BE DISCHARGED WITHOUT DISTURBING OR UNSTABILIZING THE SURROUNDING ENVIRONMENT.
 - SEDIMENT FROM THE DEWATERING INFILTRATION BASINS OR BAG SHALL BE DISPOSED OF PER NHDES REGULATIONS.
- A MEMORANDUM OF UNDERSTANDING (MOU) WILL BE OBTAINED FROM EACH PARCEL OWNER WHERE WORK PROPOSED AS SHOWN EXTENDS BEYOND THE CITY RIGHT-OF-WAY, OR WHERE TEMPORARY CONSTRUCTION ACCESS ON PRIVATE PROPERTY IS NECESSARY.
- OVERHEAD UTILITY LINES NOT SHOWN FOR CLARITY.

PORTSMOUTH, NEW HAMPSHIRE

MAPLEWOOD AVENUE OVER NORTH MILL POND

WETLAND IMPACTS PLAN

PROJECT NO. 2090511000
SHEET NO.

10

SHEET 10 OF 20

HOYLE TANNER
 Peace International Tradeport
 100 International Drive, Suite 360
 Portsmouth, NH 03801
 (603) 431-2520 www.hoyletanner.com

REV.	DESCRIPTION	DATE

NHDOT BRIDGE NO. 2317103
 DESIGNED RPM
 DRAWN WCT/AG
 CHECKED AML
 SCALE AS SHOWN
 DATE AUGUST 2023

TAX MAP 123 LOT 9
 JACKSON POINT LLC
 PO BOX 1131 RYE, NH 03870
 R.C.R.D. BOOK 5540, PAGE 2145

TAX MAP 123 LOT 10
 31 RAYES LLC
 C/O PORTSMOUTH CHEVROLET
 549 ROUTE 1 BYPASS
 PORTSMOUTH, NH 03801
 R.C.R.D. BOOK 4676, PAGE 654

TAX MAP 123 LOT 2
 230 MAPLEWOOD AVE LLC
 30 SPRING ST
 PORTSMOUTH, NH 03801
 R.C.R.D. BOOK 6179, PAGE 1474

TAX MAP 123 LOT 1
 230 MAPLEWOOD AVE LLC
 30 SPRING ST
 PORTSMOUTH, NH 03801
 R.C.R.D. BOOK 6179, PAGE 1454

TAX MAP 123 LOT 4
 REGAN ELECTRIC CO. INC.
 94 LANGDON STREET
 PORTSMOUTH, NH 03801
 R.C.R.D. BOOK 2227, PAGE 1517

TAX MAP 124 LOT 7
 GIDEON WALKER HOUSE TRUST
 JAMES H HOMES JR. TRUSTEE
 154 MAPLEWOOD AVE
 PORTSMOUTH, NH, 03801

This document is prepared as an instrument of service and shall remain the property of Hoyle Tanner. It may not be used, reproduced, disseminated or transferred in any manner, including electronically, for any other purpose than the project, without the written permission of Hoyle Tanner.

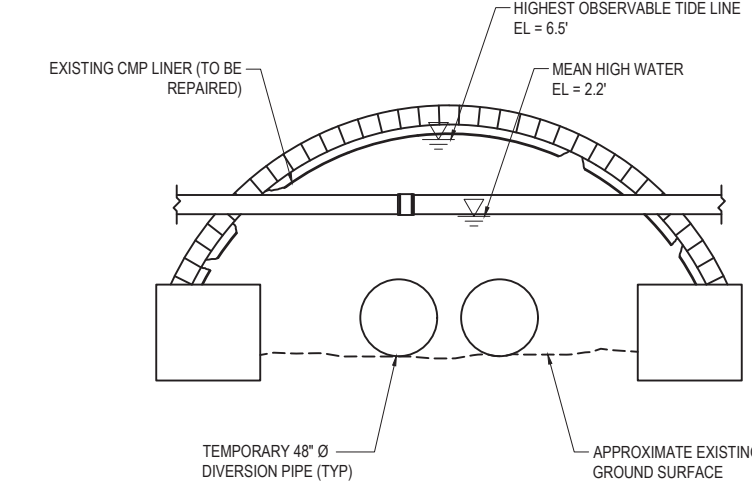
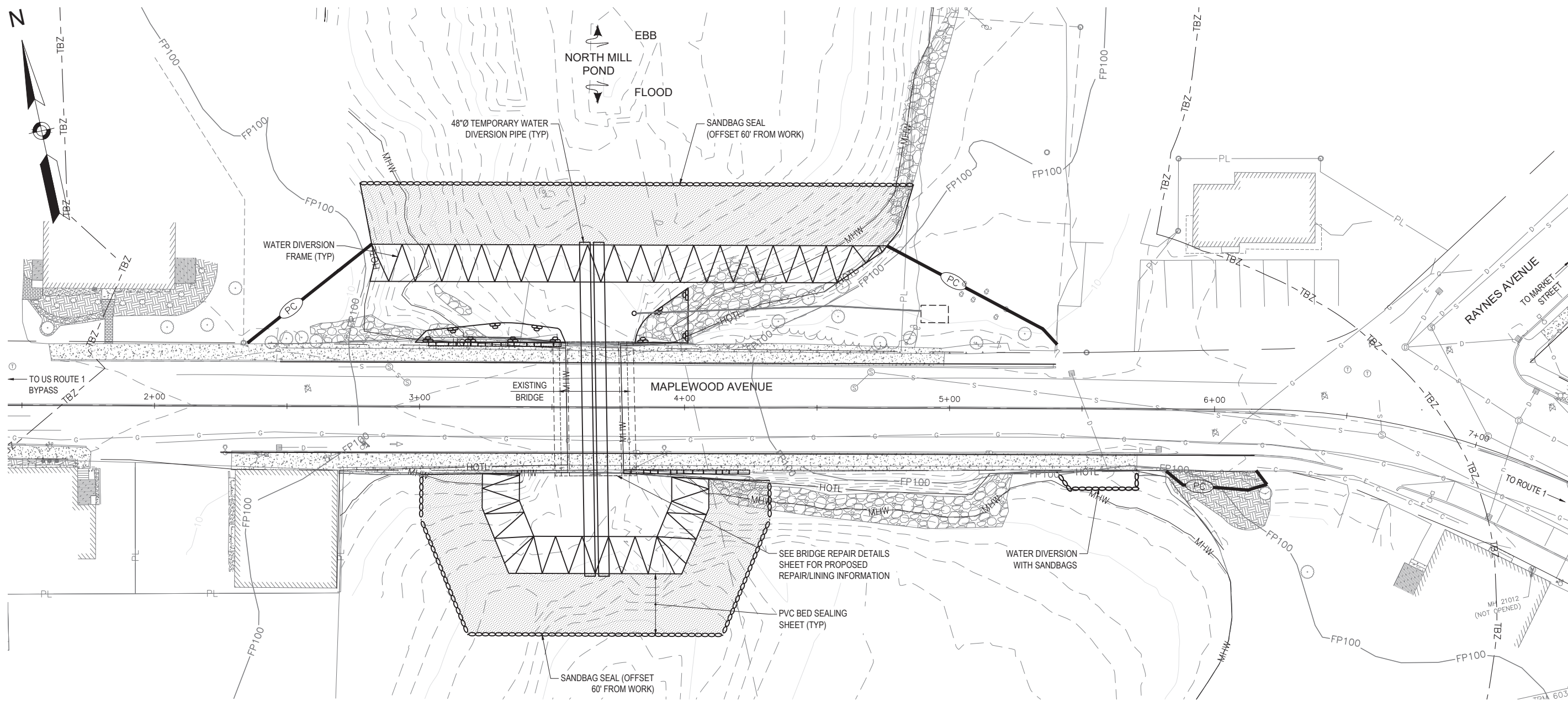

NOTE

1. MAXIMUM VELOCITY THROUGH DIVERSION PIPES ESTIMATED AT 11.3 FPS.

WATER DIVERSION SECTION
SCALE: 1" = 5'

WATER DIVERSION PLAN
0 20 50 100

HYDRAULIC DATA

1. VALUES INDICATED BELOW ARE WITH THE WATER DIVERSION SYSTEM IN PLACE.

FLOW CHARACTERISTICS

- MAX FLOW NORTH TO SOUTH = 285 CFS
- MAX FLOW SOUTH TO NORTH = 235 CFS
- MAX VELOCITY THROUGH PIPES = 11.3 FPS

PEAK WATER SURFACE ELEVATIONS

- NORTH COFFERDAM = 6.42'
- SOUTH COFFERDAM = 3.61'

REV	DESCRIPTION	DATE

HOYLE TANNER
 Pease International Tradeport
 100 International Drive, Suite 360
 Portsmouth, NH 03801
 (603) 431-2520 www.foyletanner.com

PORTSMOUTH, NEW HAMPSHIRE
 MAPLEWOOD AVENUE OVER NORTH MILL POND
 WATER DIVERSION PLAN

PROJECT NO. 2090511000
 SHEET NO.

8/23/2023 4:36 PM
 K:\PROJECTS\Portsmouth-NH\20_05110_00-Maplewood-Avenue-Bridge\CADD\Cadd\Drawings\2090511000\WaterPlan.dwg

This document is prepared as an instrument of service and shall remain the property of Hoyle Tanner. It may not be used, reproduced, disseminated or transferred in any manner, including electronically, for any other purpose than this project, without the written permission of Hoyle Tanner.

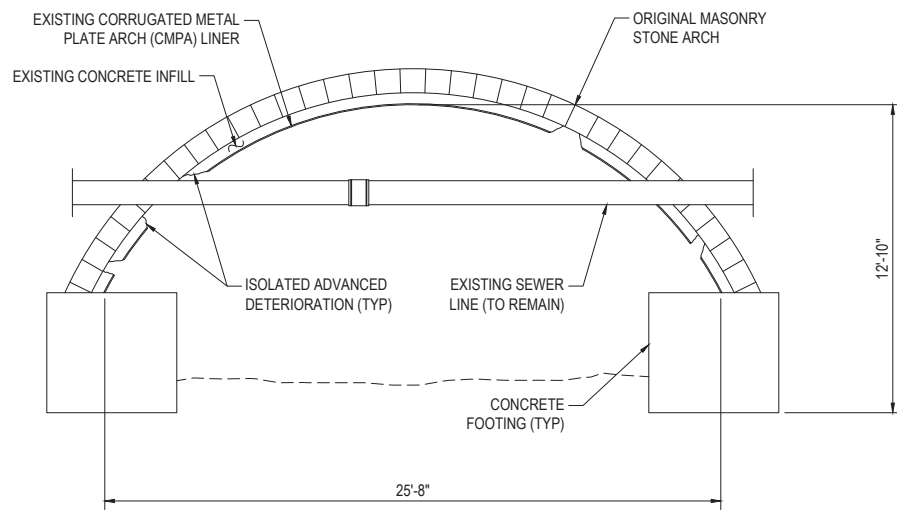

EXISTING BRIDGE SECTION

SCALE: 1/4" = 1'-0"

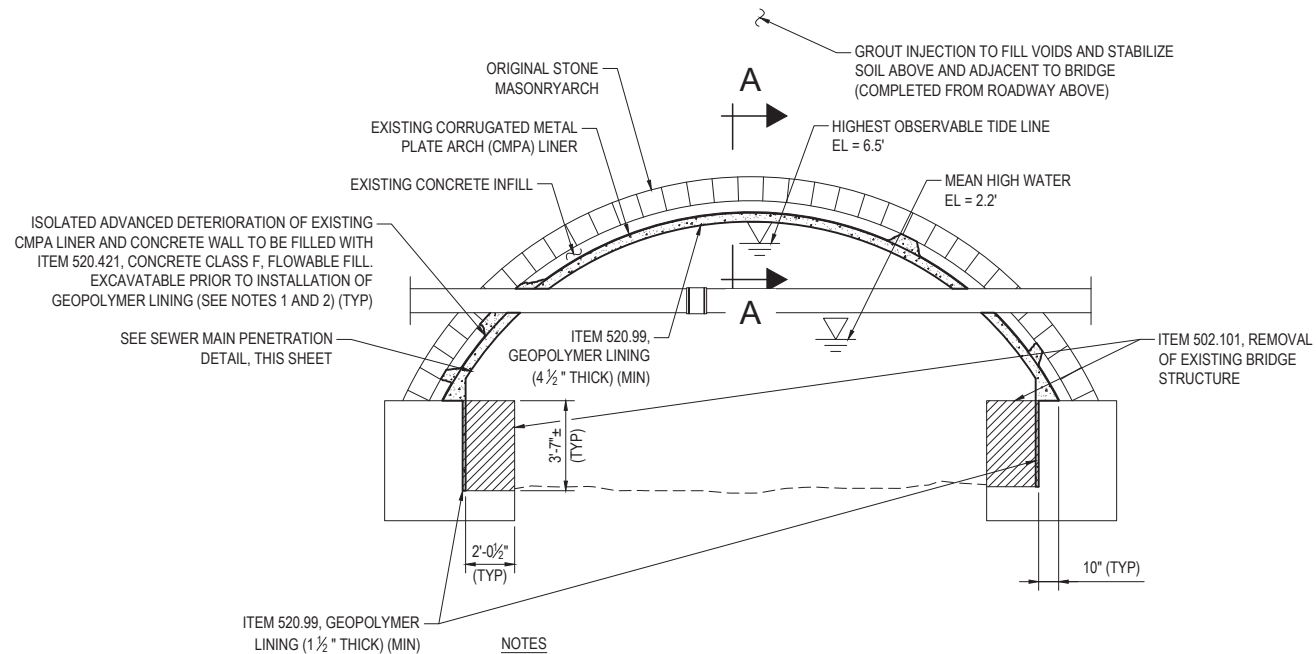

NOTES

1. AN ALTERNATE MATERIAL MAY BE USED IN LIEU OF CONCRETE CLASS F, FLOWABLE FILL WITH PRIOR APPROVAL FROM THE ENGINEER. THE ALTERNATE MATERIAL WILL BE PAID FOR UNDER ITEM 520.421.
2. SUBSURFACE CONDITIONS ARE UNKNOWN; THEREFORE, TO PREVENT LOSS OF ITEM 520.421 DOWNSTREAM CONTRACTOR SHALL MONITOR PLACEMENT OF MATERIAL AND ADJUST PLACEMENT OPERATIONS BASED ON PERFORMANCE OF INITIAL PLACEMENT.
3. RIPRAP MAY NEED TO BE TEMPORARILY MOVED AROUND THE FOOTINGS TO REMOVE CONCRETE. CONTRACTOR TO COORDINATE WITH ENGINEER ON FINAL LOCATION OF MOVED RIPRAP AFTER CONCRETE WORK IS COMPLETE.

PROPOSED BRIDGE SECTION

SCALE: 1/4" = 1'-0"

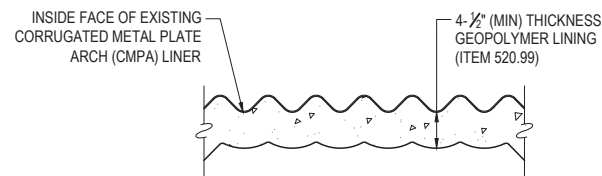

NOTE

1. FULL EXTENT OF DETERIORATION OF CONCRETE INFILL AND EXISTING STONE MASONRY ARCH ARE NOT KNOWN AND ARE NOT SHOWN IN THIS SECTION.

SECTION A-A

SCALE: 1" = 1'-0"



SEWER MAIN PENETRATION DETAIL

SCALE: 1" = 1'-0"

REV.	DESCRIPTION	DATE

HOYLE TANNER
 Pease International Tradeport
 100 International Drive, Suite 360
 Portsmouth, NH 03801
 (603) 431-2520 www.hoyletanner.com

PORTSMOUTH, NEW HAMPSHIRE
 MAPLEWOOD AVENUE OVER NORTH MILL POND
 BRIDGE REPAIR DETAILS

PROJECT NO. 2090511000
 SHEET NO.

8/23/2023 4:36 PM
 K:\PROJECTS\Portsmouth-NH\20_05110_00-Maplewood-Avenue-Bridge\CADD\Cutsheets\2090511000\DT00.dwg

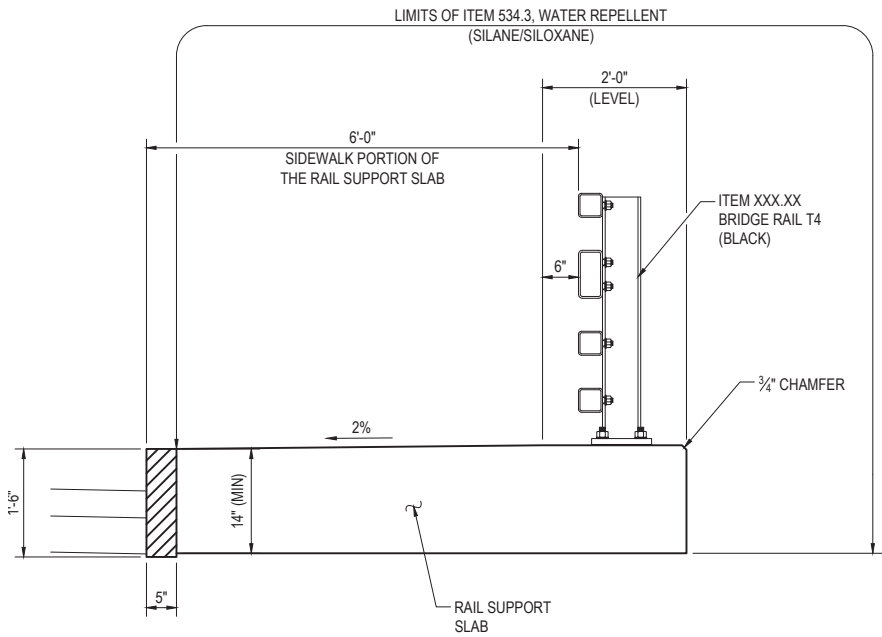

RAIL SUPPORT SLAB TYPICAL SECTION

SCALE: 3/4" = 1'-0"

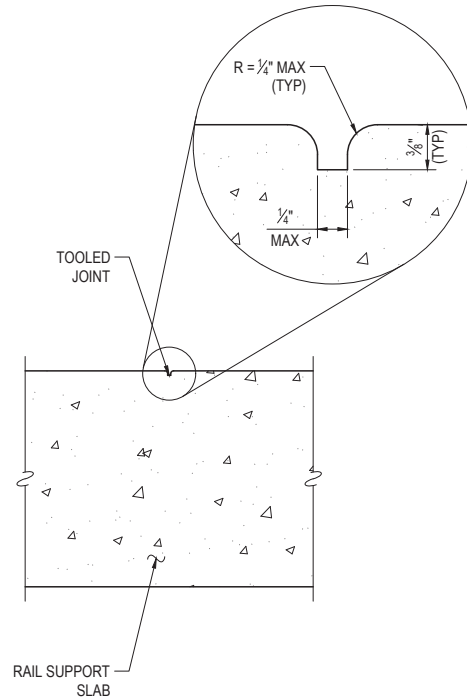

SECTION B-B

SCALE: 1 1/2" = 1'-0"

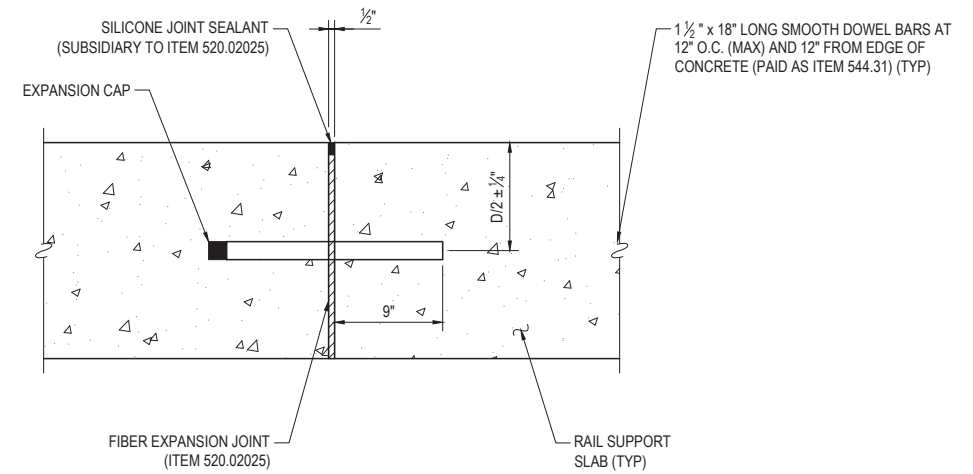

SECTION C-C

SCALE: 1 1/2" = 1'-0"

PORTSMOUTH, NEW HAMPSHIRE
 MAPLEWOOD AVENUE OVER NORTH MILL POND
 RAIL SUPPORT SLAB
 CONSTRUCTION DETAILS (1 OF 2)

PROJECT NO. 2090511000
 SHEET NO.

14

SHEET 14 OF 20

Pease International Tradeport
 100 International Drive, Suite 360
 Portsmouth, NH 03801
 (603) 431-2320 www.foyletanner.com

REV.	DESCRIPTION	DATE

NHDOT BRIDGE NO. 2317103
 DESIGNED RPM
 DRAWN WCT/JAG
 CHECKED AML
 SCALE AS SHOWN
 DATE AUGUST 2023

This document is prepared as an instrument of service and shall remain the property of Hoyle Tanner. It may not be used, reproduced, disseminated or transferred in any manner, including electronically, for any other purpose than this project, without the written permission of Hoyle Tanner.

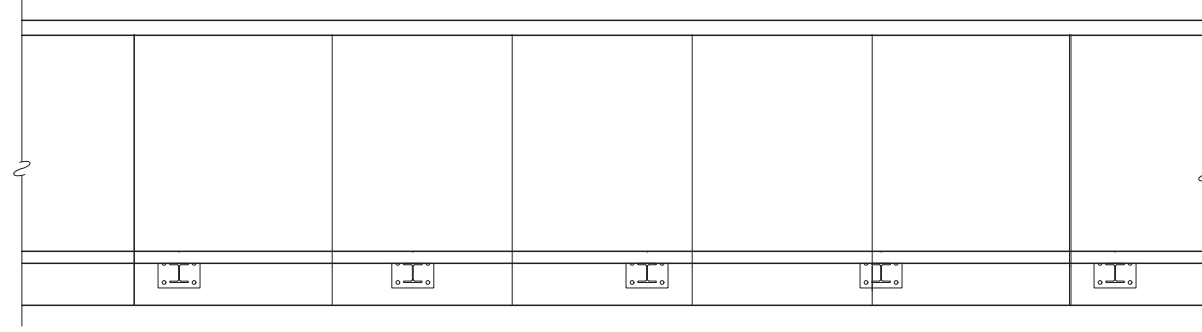

TYPICAL RAIL SUPPORT SLAB JOINT SPACING

SCALE: 3/8" = 1'-0"

NOTES

1. THE MINIMUM DISTANCE BETWEEN EXPANSION JOINTS IS XX'-XX".
2. THE MAXIMUM DISTANCE BETWEEN EXPANSION JOINTS IS XX'-XX".
3. EXPANSION JOINTS SHALL BE LOCATED A MINIMUM OF 1'-3" FROM THE CENTERLINE OF RAIL POSTS.

PORTSMOUTH, NEW HAMPSHIRE
 MAPLEWOOD AVENUE OVER NORTH MILL POND
 RAIL SUPPORT SLAB
 CONSTRUCTION DETAILS (2 OF 2)



PROJECT NO. 2090511000
 SHEET NO.

15

SHEET 15 OF 20

REV.	DESCRIPTION	DESIGNED	DRAWN	CHECKED	SCALE	DATE
		RPM	WCT/AG	AML	AS SHOWN	AUGUST 2023

This document is prepared as an instrument of service and shall remain the property of Hoyle Tanner. It may not be used, reproduced, disseminated or transferred in any manner, including electronically, for any other purpose than this project, without the written permission of Hoyle Tanner.

Existing Conditions Plans

NOTES:

- REFERENCE: MAPLEWOOD AVENUE BRIDGE
D.S.I. PROJECT NO. 6032
- FIELD SURVEY PERFORMED BY D.J.B. & J.H.H. DURING DECEMBER 2019 & JANUARY 2020 USING A TRIMBLE S7 TOTAL STATION AND A TRIMBLE R10 SURVEY GRADE GPS WITH A TRIMBLE TSC3 DATA COLLECTOR AND A TRIMBLE DINI DIGITAL LEVEL. TRAVERSE ADJUSTMENT BASED ON LEAST SQUARE ANALYSIS.
- FIELD SURVEY PERFORMED BY M.J.C. DURING NOVEMBER 2019 USING A LEICA HDS SCANNER. REGISTRATION ADJUSTMENT BASED ON LEAST SQUARE ANALYSIS.
- HORIZONTAL DATUM BASED ON NAD83(2011) NEW HAMPSHIRE STATE PLANE COORDINATE ZONE (2800) DERIVED FROM REDUNDANT GPS OBSERVATIONS UTILIZING THE KEYNET GPS VRS NETWORK.
- VERTICAL DATUM IS BASED ON NAVD88 PER DISK B2, ELEV.=19.56'; (NGVD29 ELEV.=20.32 (-0.76 TO NAVD88)).
- THOMAS SOKOLOSKI, CERTIFIED WETLAND SCIENTIST #127, OF TES ENVIRONMENTAL CONSULTANTS, L.L.C. OF BOW, NH, PERFORMED THE WETLAND MAPPING (HIGHEST OBSERVABLE TIDE LINE) ON FEBRUARY 28, 2020 ACCORDING TO THE CORPS OF ENGINEERS WETLAND DELINEATION MANUAL AND THE REGIONAL SUPPLEMENT TO THE CORPS OF ENGINEERS WETLAND DELINEATION MANUAL- NORTH-CENTRAL AND NORTHEAST REGION, VERSION 2.0, JANUARY 2012, US ARMY CORPS OF ENGINEERS.
- PROPER FIELD PROCEDURES WERE FOLLOWED IN ORDER TO GENERATE CONTOURS AT 2' INTERVALS. ANY MODIFICATION OF THIS INTERVAL WILL DIMINISH THE INTEGRITY OF THE DATA, AND DOUCET SURVEY WILL NOT BE RESPONSIBLE FOR ANY SUCH ALTERATION PERFORMED BY THE USER.
- UNDERGROUND UTILITIES SHOWN HEREON ARE BASED ON OBSERVED PHYSICAL EVIDENCE AND PAINT MARKS FOUND ON-SITE.
- THE ACCURACY OF MEASURED UTILITY INVERTS AND PIPE SIZES/TYPES IS SUBJECT TO NUMEROUS FIELD CONDITIONS, INCLUDING: THE ABILITY TO MAKE VISUAL OBSERVATIONS, DIRECT ACCESS TO THE VARIOUS ELEMENTS, MANHOLE CONFIGURATION, ETC.
- DUE TO THE COMPLEXITY OF RESEARCHING ROAD RECORDS AS A RESULT OF INCOMPLETE, UNORGANIZED, INCONCLUSIVE, OBLITERATED, OR LOST DOCUMENTS, THERE IS AN INHERENT UNCERTAINTY INVOLVED WHEN ATTEMPTING TO DETERMINE THE LOCATION AND WIDTH OF A ROADWAY RIGHT OF WAY. THE EXTENT OF MAPLEWOOD AVENUE AS DEPICTED HEREON IS/ARE BASED ON RESEARCH CONDUCTED AT THE ROCKINGHAM COUNTY REGISTRY OF DEEDS, NEW HAMPSHIRE DEPARTMENT OF TRANSPORTATION AND THE CITY OF PORTSMOUTH.

NO DEFINED RIGHT OF WAY WIDTH OR LAYOUT WAS FOUND FOR MAPLEWOOD AVENUE. THE BASIS FOR THE DETERMINED EDGE OF RIGHT OF WAY IS LISTED BELOW. DUE TO THE LACK OF LAYOUT, RIGHT OF WAY WIDTH AND BOUNDARY MONUMENTS IN SOME AREAS, DISCUSSIONS WITH ABUTTERS WOULD BE RECOMMENDED PRIOR TO ANY WORK THAT WOULD AFFECT EXISTING IMPROVEMENTS ON ABUTTING LOTS.

- EDGE OF RIGHT OF WAY BASED ON HOLDING 52 FOOT WIDE RIGHT OF WAY ALONG RAYNES AVENUE PER REFERENCE PLANS #6 & #7. THE GEOMETRY FROM REFERENCE PLAN #7 WAS THEN ALIGNED TO THE REBAR SHOWN ON THE NORTHERLY SIDE OF MAPLEWOOD AVENUE.
- EDGE OF RIGHT OF WAY BASED ON REFERENCE PLAN #4 ALIGNED TO MONUMENTS FOUND IN THE FIELD.
- EDGE OF RIGHT OF WAY BASED ON REFERENCE PLANS #10, 12, 13, 14 & 18 ALIGNED TO MONUMENTS FOUND IN THE FIELD.
- EASTERLY EDGE OF RIGHT OF WAY OF DEARBORN STREET AND MAPLEWOOD AVENUE BASED ON REFERENCE PLAN #15 ALIGNED TO MONUMENTS FOUND IN THE FIELD.
- WESTERLY EDGE OF DEARBORN STREET BASED ON 30' OFFSET FROM EASTERLY SIDE OF DEARBORN STREET (SEE NOTE #100). DOUCET SURVEY WAS NOT ABLE TO VERIFY THE 30' WIDTH OF DEARBORN STREET WITH THE CITY OF PORTSMOUTH.
- EDGE OF RIGHT OF WAY BASED ON APPROXIMATE BACK EDGE OF SIDE WALK AND DEED DISTANCES DUE TO A LACK OF BOUNDARY EVIDENCE AND/OR PLANS IN THIS AREA.
- EDGE OF RIGHT OF WAY BASED ON HOLDING A STRAIGHT LINE FROM THE REBAR AT THE SOUTHEAST CORNER OF TAX MAP 123, LOT 9 AND THE DETERMINED SOUTHWEST CORNER OF TAX MAP 123, LOT 10.
- EDGE OF RIGHT OF WAY BASED ON REFERENCE PLAN #16 HOLDING THE DRILL HOLE AT THE NORTHWEST CORNER OF THE LOT IN THE STONE SEAWALL AND FITTING TO EXISTING BUILDING CORNERS ALONG MAPLEWOOD AVENUE. THE STONE SEAWALL ALONG NORTH MILL POND APPEARS TO HAVE BEEN REBUILT SINCE 1995 AND ADDITIONAL MONUMENTS ON THE LOT AND ABUTTING LOTS WERE NOT FOUND IN THE FIELD.
- EDGE OF RIGHT OF WAY BASED ON HOLDING DETERMINED NORTHEASTERLY CORNER LOCATION OF TAX MAP 123, LOT 2 AND THE BUILDING FACE ON TAX MAP 123, LOT 1. NO BOUNDARY MONUMENTS WERE FOUND FOR TAX MAP 123, LOT 1.
- EDGE OF RIGHT OF WAY BASED ON HOLDING A STRAIGHT LINE BETWEEN THE NORTHEASTERLY BUILDING CORNER OF TAX MAP 123, LOT 1 AND THE DRILL HOLE IN THE STONE SEAWALL AT THE NORTHWESTERLY CORNER OF TAX MAP 124, LOT 7.

- WATER BOUNDARIES ARE DYNAMIC IN NATURE AND ARE SUBJECT TO CHANGE DUE TO NATURAL CAUSES SUCH AS EROSION OR ACCRETION.
- ALL UNDERGROUND UTILITIES (ELECTRIC, GAS, TEL. WATER, SEWER DRAIN SERVICES) ARE SHOWN IN SCHEMATIC FASHION, THEIR LOCATIONS ARE NOT PRECISE OR NECESSARILY ACCURATE. NO WORK WHATSOEVER SHALL BE UNDERTAKEN USING THIS PLAN TO LOCATE THE ABOVE SERVICES. CONSULT WITH THE PROPER AUTHORITIES CONCERNED WITH THE SUBJECT SERVICE LOCATIONS FOR INFORMATION REGARDING SUCH. CALL DIG-SAFE AT 1-888-DIG-SAFE.
- UAS LIDAR MAPPING CONDUCTED BY ARE CORPORATION ON NOVEMBER 14, 2019. THE LIDAR DERIVED PRODUCT WAS PRODUCED TO MEET ASPRS 2.5cm HORIZONTAL AND 5cm VERTICAL ACCURACY CLASSES. THE FLIGHT OPERATION MAXIMIZED THE COVERAGE AREA AT LOW TIDE.

14. NORTH SIDE OF MAPLEWOOD AVENUE BRIDGE
MEAN HIGH WATER ELEVATION 3.0' (NGVD1929) CONVERTED TO ELEVATION 2.2' (NAVD88), SEE NOTE #5.
SOUTH SIDE OF MAPLEWOOD AVENUE BRIDGE
MEAN HIGH WATER ELEVATION 2.9' (NGVD1929) CONVERTED TO ELEVATION 2.1' (NAVD88), SEE NOTE #5.

ELEVATIONS PER "MAPLEWOOD AVENUE CULVERT REPLACEMENT AND NORTH MILL POND RESTORATION, WATERFRONT/STRUCTURAL BASIS OF DESIGN, BY WATERFRONT ENGINEERS, LLC, DATED DECEMBER 30, 2009", PROVIDED BY TIGHE & BOND ON 11-30-15.

COMPLETE BOUNDARY RESEARCH AND FIELD WORK WAS NOT COMPLETED FOR TAX MAP 123, LOTS 1, 9 & 10 AND TAX MAP 124, LOT 7 AS PART OF THIS SURVEY AND OWNERSHIP RIGHTS TO STRIPS OF LAND BETWEEN SAID PARCELS, THE MEAN HIGH WATER LINE AND MAPLEWOOD AVENUE HAVE NOT BEEN DETERMINED. MEAN HIGH WATER WAS DETERMINED PER THE ABOVE MENTIONED DOCUMENT BY WATERFRONT ENGINEERS AND APPEARS TO BE THE BOUNDARY LIMITS OF THE ABOVE MENTIONED PARCELS PER CURRENT DEED DESCRIPTIONS. COMMUNICATION WITH THE ABUTTING LAND OWNERS AND THE CITY OF PORTSMOUTH IS RECOMMENDED PRIOR TO ANY WORK IN THESE AREAS.

REFERENCE PLANS:

- "PROPERTY STAKEOUT SKETCH, PORTSMOUTH PROPERTY TRUST, PE SPAULDING REVOCABLE TRUST", BY AMBIT ENGINEERING, INC., DATED JANUARY 30, 2007, NOT RECORDED.
- "VAUGHAN STREET URBAN RENEWAL PROJECT N.H. R-10 PORTSMOUTH, NH. CONDEMNATION MAP", BY ANDERSON-NICHOLS & CO., INC., DATED FEBRUARY 1971, R.C.R.D. PLAN D-2425.
- "STANDARD BOUNDARY SURVEY, TAX MAP 123, LOTS 10 & 13 FOR RAYNES, LLC", BY AMBIT ENGINEERING, INC., NOT RECORDED.
- "STANDARD PROPERTY SURVEY FOR PROPERTY AT 111 MAPLEWOOD AVENUE", BY EASTERLY SURVEYING, INC., DATED 1/31/06, R.C.R.D. PLAN #D-33786.
- "VAUGHAN STREET URBAN RENEWAL PROJECT N.H. R-10 PORTSMOUTH, NH. DISPOSITION PLAN PARCEL 3", BY ANDERSON-NICHOLS & CO., INC., DATED JUNE 1973, R.C.R.D. PLAN D-4019.
- "VAUGHAN STREET URBAN RENEWAL PROJECT N.H. R-10 PORTSMOUTH, NH. DISPOSITION MAP", BY ANDERSON-NICHOLS & CO., INC., DATED NOVEMBER 1969, R.C.R.D. PLAN D-2408.
- "LAND OF HEIRS OF JOHN AUGUST HETT", BY JOHN W. DURGIN, DATED APRIL 1938, ON FILE AT JAMES VERRA AND ASSOCIATES.
- "PLOT PLAN OF LAND PORTSMOUTH, NH FOR JOHN R. AND WINFIELD R. WELCH", BY JOHN W. DURGIN, DATED APRIL 1973, ON FILE AT JAMES VERRA AND ASSOCIATES.
- "PROPERTY OF ELDRED V. AND BARBARA J. STRAW", BY C.R.E. LAWSON, DATED JUNE 1971, R.C.R.D. PLAN C-3277.
- "EASEMENT PLAN MAP 123, LOT 9, TWO HUNDRED THIRTY FIVE MAPLEWOOD AVENUE, LLC TO THE CITY OF PORTSMOUTH", BY AMBIT ENGINEERING, INC., DATED SEPTEMBER 2000, R.C.R.D. PLAN D-28893.

- "TAKING PLAN OF LAND IN PORTSMOUTH, NH", BY WHITMAN & HOWARD, INC., DATED APRIL 30, 1985, R.C.R.D. PLAN C-15117.
- "BOUNDARY LINE PLAN PURSUANT TO RSA. 472, FOR HEIRS OF LENORA M. MOREAU AND KATHERINE M. KLOPMAN", BY EMERY ENGINEERING, DATED JULY 16, 1996, R.C.R.D. PLAN C-24837.
- "CONDOMINIUM SITE PLAN MAP 141, LOT 37, NORTH MILL POND CONDOMINIUM FOR BRADLEY P. BOISVERT", BY AMBIT ENGINEERING, INC., DATED MARCH 2003, R.C.R.D. PLAN D-30629.
- "CONDOMINIUM SITE PLAN, 295 MAPLEWOOD AVENUE CONDOMINIUM ASSOCIATION, PROPERTY OF DEBORAH J. CAMPBELL", BY MSC CIVIL ENGINEERS & LAND SURVEYORS, INC., DATED JUNE 22, 2005, R.C.R.D. PLAN D-35561.
- "SUBDIVISION & LOT LINE REVISION, LAND OF BRIAN & SUSAN REGAN & REGAN ELECTRIC", BY BERRY SURVEYING & ENGINEERING, DATED OCTOBER 18, 2018, R.C.R.D. PLAN D-41471.
- "SITE PLAN, GIDEON WALKER HOUSE", BY BARRY W. KIMBALL, LAND SURVEYOR, DATED JUNE 1995, R.C.R.D. PLAN D-25362.
- "CAPTAIN JOHN MOSES CONDOMINIUM SITE PLAN DRAWN FOR DANIEL LOBOVITS", BY EDWARD N. HERBERT, ASSOC. INC., DATED MARCH 1995, R.C.R.D. PLAN C-23805.
- "PLAN OF LAND PROPERTY OF EVON COOPER", BY AMES MSC, DATED MARCH 6, 2007, R.C.R.D. PLAN D-34698.

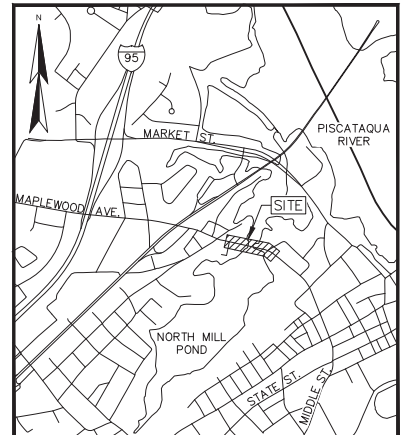

LOCATION MAP (n.t.s.)

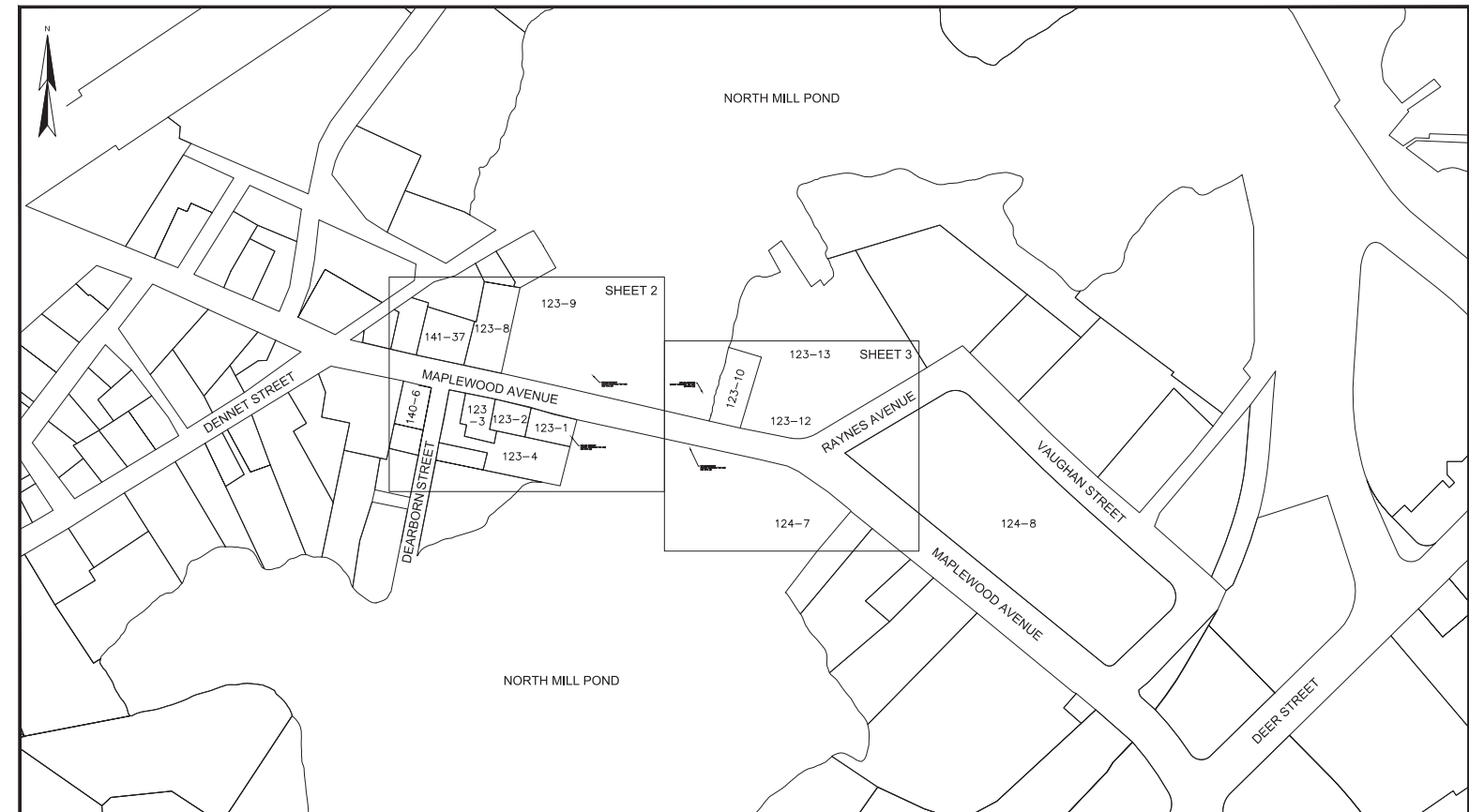

KEY MAP

ABUTTERS INFO:

- | | | | |
|--|--|---|--|
| TAX MAP 123 LOT 1
MBRT ENTERPRISES LLC
10 NORDIC LANE
ROLLINSFORD, NH 03869
R.C.R.D. BOOK 4878, PAGE 2539 | TAX MAP 123 LOT 4
REGAN ELECTRIC CO. INC.
94 LANGDON STREET
PORTSMOUTH, NH 03801
R.C.R.D. BOOK 2227, PAGE 1517 | TAX MAP 123 LOT 10
31 RAYNES LLC
C/O PORTSMOUTH CHEVROLET
549 ROUTE 1 BYPASS
PORTSMOUTH, NH 03801
R.C.R.D. BOOK 4676, PAGE 654 | TAX MAP 124 LOT 7
GIDEON WALKER HOUSE TRUST
JAMES H HOMES JR. TRUSTEE
154 MAPLEWOOD AVE
PORTSMOUTH, NH, 03801 |
| TAX MAP 123 LOT 2
BMT ENTERPRISES
10 NORDIC LANE
ROLLINSFORD, NH 03869
R.C.R.D. BOOK 3818, PAGE 1939 | TAX MAP 123 LOT 8
JOSEPH W. NELSON REV. TRUST
JOSEPH W. NELSON, TRUSTEE
259 MAPLEWOOD AVENUE
PORTSMOUTH, NH 03801
R.C.R.D. BOOK 5812, PAGE 1789 | TAX MAP 123 LOT 12
203 MAPLEWOOD AVENUE LLC
549 US HIGHWAY 1 BYPASS
PORTSMOUTH, NH 03801
R.C.R.D. BOOK 5621, PAGE 420 | TAX MAP 124 LOT 8
111 MAPLEWOOD AVENUE LLC
210 COMMERCE WAY SUITE 300
PORTSMOUTH, NH, 03801
R.C.R.D. BOOK 6026 PAGE 2219 |
| TAX MAP 123 LOT 3
MICHAEL J. & DIANE REGAN REV. TRUST
MICHAEL J. & DIANE REGAN, TRUSTEES
PO BOX 72
GREENLAND, NH 03840
R.C.R.D. BOOK 5330, PAGE 6 | TAX MAP 123 LOT 9
JACKSON POINT LLC
PO BOX 1131
RYE, NH 03870
R.C.R.D. BOOK 5540, PAGE 2145 | TAX MAP 123 LOT 13
31 RAYNES LLC
C/O PORTSMOUTH CHEVROLET
549 ROUTE 1 BYPASS
PORTSMOUTH, NH 03801
R.C.R.D. BOOK 4676, PAGE 657 | TAX MAP 140 LOT 6
JOAN P. McNALLY
276 MAPLEWOOD AVENUE
PORTSMOUTH, NH 03801
R.C.R.D. BOOK 3020, PAGE 1116 |
| | | | TAX MAP 141 LOT 37
NO ASSESSING INFORMATION AVAILABLE |

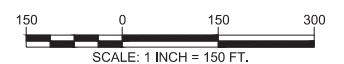

EXISTING CONDITIONS PLAN
FOR
HOYLE, TANNER & ASSOCIATES, INC
OF
NHDOT BRIDGE NO. 231/103
MAPLEWOOD AVENUE
PORTSMOUTH, NEW HAMPSHIRE

NO.	DATE	DESCRIPTION	BY

DRAWN BY:	W.D.C.	DATE:	FEBRUARY 17, 2020
CHECKED BY:	M.W.F.	DRAWING NO.	6032A
JOB NO.	6032	SHEET	1 OF 3

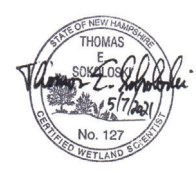

DOUCET SURVEY
Serving Your Professional Surveying & Mapping Needs
102 Kent Place, Newmarket, NH 03857 (603) 659-6560
2 Commerce Drive (Suite 202) Bedford, NH 03110 (603) 614-4060
10 Storer Street (Riverview Suite) Kennebunk, ME (207) 502-7005
http://www.doucetsurvey.com



5/8" REBAR FND.
 ○ UP 4" W/D CAP COLWELL
 ○ 5/8" REBAR FND.
 ○ UP 4" W/D CAP 844

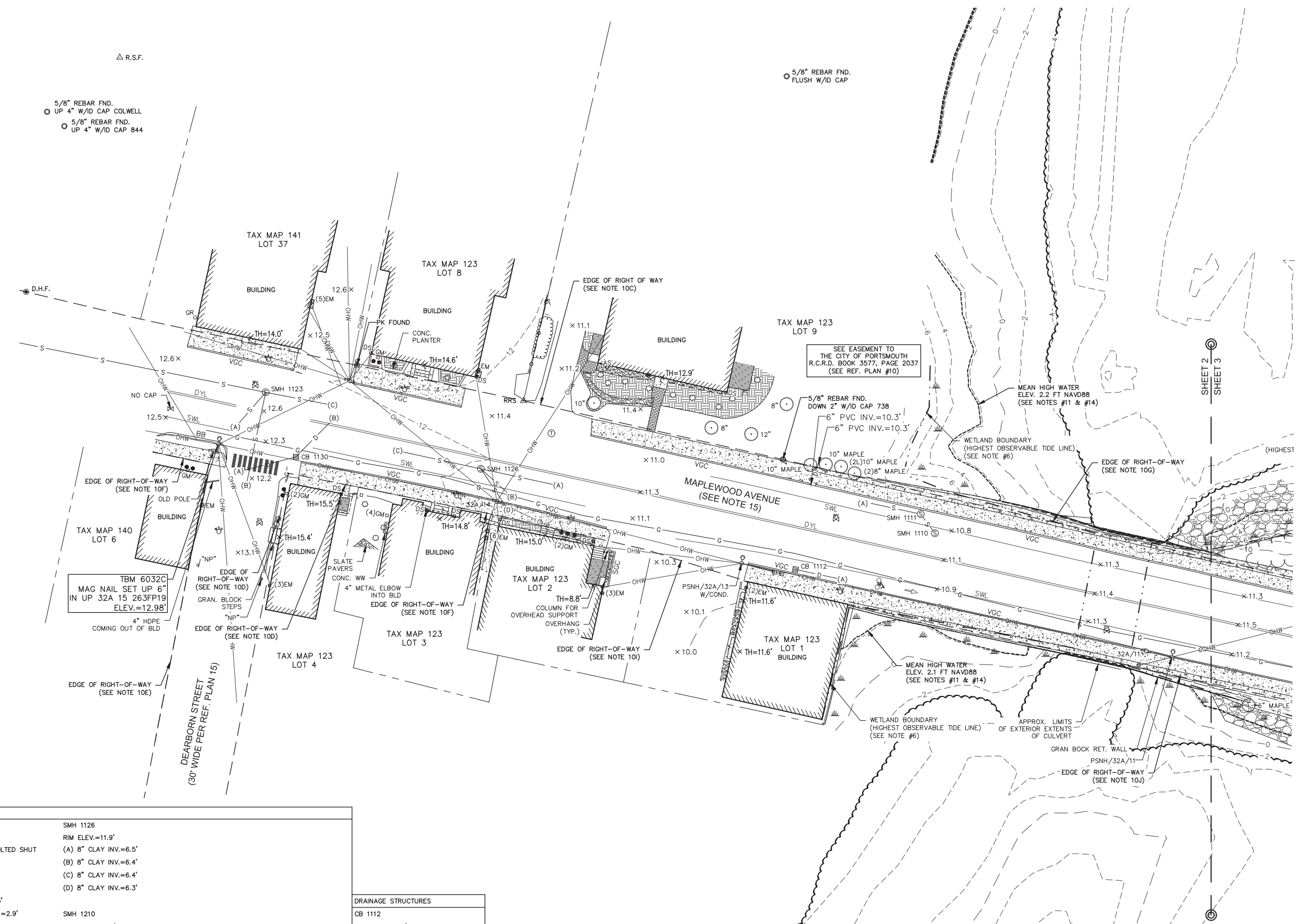

LEGEND

- APPROXIMATE ABUTTERS LOT LINE
- APPROXIMATE RIGHT-OF-WAY LINE
- STOCKADE FENCE
- PICKET FENCE
- CHAIN LINK FENCE
- METAL GUARDRAIL
- OHW OVERHEAD WIRE
- S SEWER LINE
- D DRAIN LINE
- G GAS LINE
- C UNDERGROUND CABLE TV LINE
- 100 MAJOR CONTOUR LINE
- 98 MINOR CONTOUR LINE
- (100) MAJOR CONTOUR LINE (LIDAR SURFACE)
- (98) MINOR CONTOUR LINE (LIDAR SURFACE)
- TREE LINE
- SHRUB LINE
- EDGE OF WETLAND
- WETLAND AREA
- CONCRETE
- CRUSHED STONE
- RIP RAP
- LANDSCAPED AREA
- BRICK
- UTILITY POLE
- UTILITY POLE & GUY WIRE
- UTILITY POLE W/LIGHT
- LIGHT POLE W/ARM
- SIGN
- BOUND FOUND
- DRILL HOLE FOUND
- IRON PIPE/ROD FOUND
- BOLLARD
- POST
- FIRE HYDRANT
- WATER GATE VALVE
- WATER SHUTOFF VALVE
- SPIGOT
- GAS GATE VALVE
- GAS REGULATOR
- ELECTRIC BOX
- CABLE BOX
- CATCH BASIN
- DRAIN MANHOLE
- MANHOLE
- TELEPHONE MANHOLE
- ELECTRIC MANHOLE
- SEWER MANHOLE
- DECIDUOUS TREE
- DECIDUOUS BUSH
- TREE STUMP
- MONITORING WELL LOCATION
- SPOT GRADE
- TYP.
- ×100.0
- BND. FND.
- D.H.F.
- R.S.S.
- R.S.F.
- R.S.F.
- CONC.
- GRAN.
- HDWL
- EP
- VGC
- SGC
- BB
- SWL
- DYL
- EM
- GM
- DS
- NP
- AS

SCALE: 1 INCH = 20 FT.

TBM 6032C
 MAG NAIL SET UP 6"
 IN UP 32A 15 263FP19
 ELEV.=12.98'
 4" HDPE
 COMING OUT OF BLD

SEE EASEMENT TO
 THE CITY OF PORTSMOUTH
 R.C.R.D. BOOK 3577, PAGE 2037
 (SEE REF. PLAN #10)

SEWER STRUCTURES	
SMH 1110	SMH 1126
RIM ELEV.=10.7'	RIM ELEV.=11.9'
UNABLE TO OPEN BOLTED SHUT	(A) 8" CLAY INV.=6.5'
	(B) 8" CLAY INV.=6.4'
	(C) 8" CLAY INV.=6.4'
	(D) 8" CLAY INV.=6.3'
SMH 1111	
RIM ELEV.=10.6'	
(A) 24" CLAY INV.=3'	
(1110) 24" CLAY INV.=2.9'	
SMH 1123	SMH 1210
RIM ELEV.=12.4'	RIM ELEV.=14.5'
(A) 6" PVC INV.=9'	(A) 2" PVC TOP OF PIPE=8.2'
(B) 10" CLAY W/ 8" INSIDE INV.=4.5'	(B) 10" PVC INV.=5.5'
(C) 30" RCP INV.=4'	(C) 10" CLAY INV.=5.2'
(1210) 24" RCP INV.=4'	(D) 32" RCP W/BRICK CHANNEL INV.=4.7'
	(E) 12" UNKN RECESSED CHANNEL INV.=4.6'
	(D) 24" RCP INV.=7.1'
	(C) 24" RCP INV.=7'
	(D) 24" RCP INV.=6.9'

DRAINAGE STRUCTURES	
CB 1112	CB 1130
RIM ELEV.=10.6'	RIM ELEV.=12.1'
(A) 8" OP INV.=6.4'	(A) 4" PVC INV.=10.6'
	(A) 4" CLAY INV.=9.2'

EXISTING CONDITIONS PLAN
 FOR
 HOYLE, TANNER & ASSOCIATES, INC
 OF
 NHDOT BRIDGE NO. 231/103
 MAPLEWOOD AVENUE
 PORTSMOUTH, NEW HAMPSHIRE

NO.	DATE	DESCRIPTION	BY

DRAWN BY:	W.D.C.	DATE:	FEBRUARY 17, 2020
CHECKED BY:	M.W.F.	DRAWING NO.	6032A
JOB NO.	6032	SHEET	2 OF 3

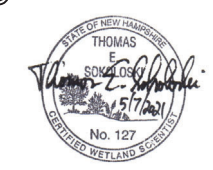

DOUCET SURVEY
 Serving Your Professional Surveying & Mapping Needs
 102 Kent Place, Newmarket, NH 03857 (603) 659-6560
 2 Commerce Drive (Suite 202) Bedford, NH 03110 (603) 614-4060
 10 Storer Street (Riverview Suite) Kennebunk, ME (207) 502-7005
 http://www.doucetsurvey.com

FILE NAME: N:\PROJECTS\6032A_CADD\6032A.dwg PLOT DATE: 02/17/2020 10:50:00 AM PLOT BY: JTD



SHEET 2
SHEET 3

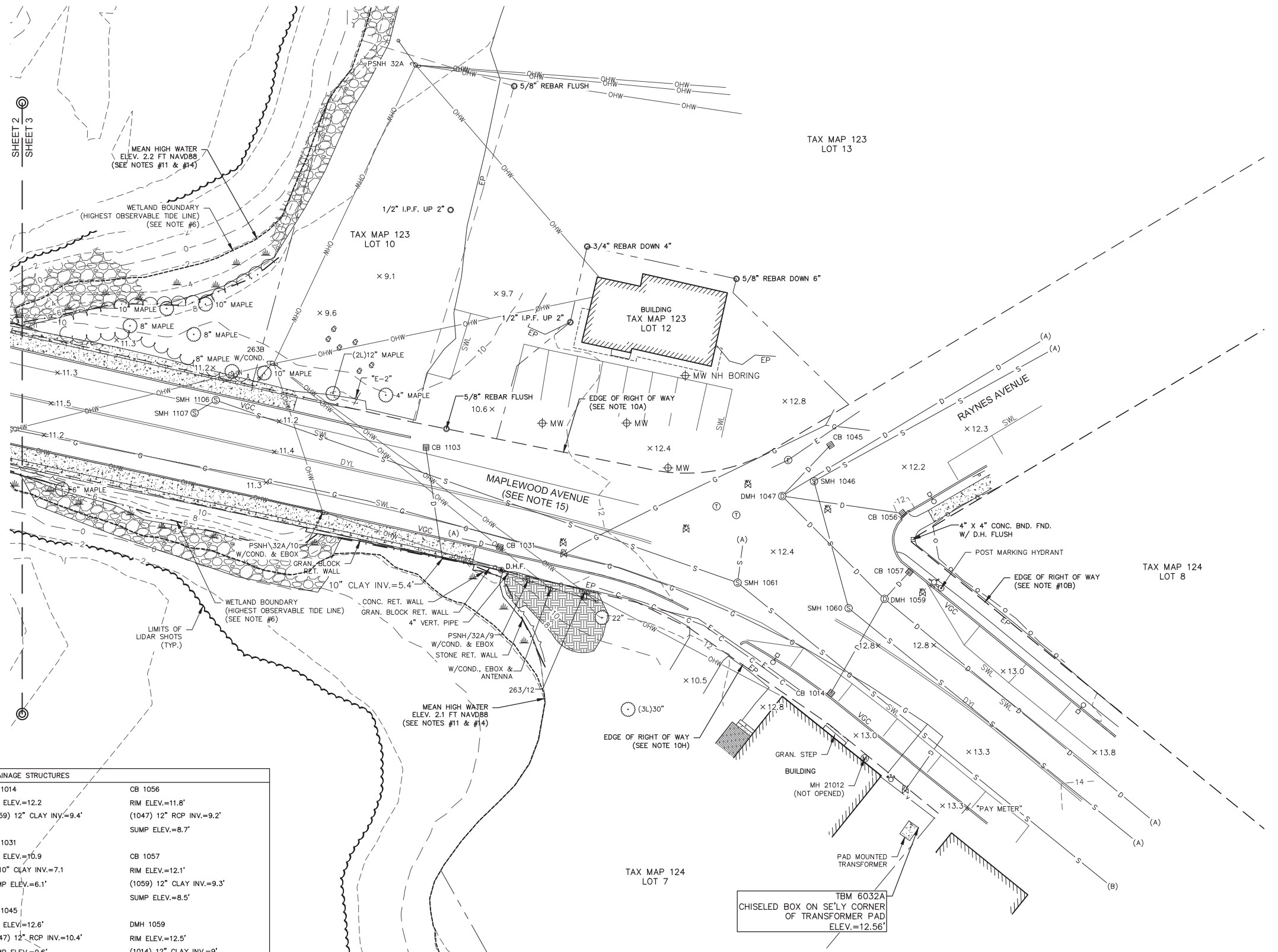

SEWER STRUCTURES

SMH 1046	RIM ELEV.=12.6'
(A) 10" PVC INV.=4.8'	
(1060) 10" CLAY INV.=4.2'	
SMH 1060	RIM ELEV.=12.6'
(1046) 12" DIP INV.=4.3'	
(A) 12" DIP INV.=4.3'	
SMH 1061	RIM ELEV.=12.4'
(A) 12" CLAY INV.=6.4'	
(1106) 24" CLAY INV.=2.2'	
(B) 24" CLAY INV.=2.2'	
SMH 1106	RIM ELEV.=11.2'
(1107) 24" CLAY INV.=2.7'	
(1061) 24" CLAY INV.=2.7'	
SMH 1107	RIM ELEV.=11.2'
(NOT OPENED?)	

DRAINAGE STRUCTURES

CB 1014	RIM ELEV.=12.2	CB 1056	RIM ELEV.=11.8'
(1059) 12" CLAY INV.=9.4'		(1047) 12" RCP INV.=9.2'	
		SUMP ELEV.=8.7'	
CB 1031	RIM ELEV.=10.9	CB 1057	RIM ELEV.=12.1'
(A) 10" CLAY INV.=7.1		(1059) 12" CLAY INV.=9.3'	
SUMP ELEV.=6.1'		SUMP ELEV.=8.5'	
CB 1045	RIM ELEV.=12.6'	DMH 1059	RIM ELEV.=12.5'
(1047) 12" RCP INV.=10.4'		(1014) 12" CLAY INV.=9'	
SUMP ELEV.=9.6'		(1057) 12" CLAY INV.=8.7'	
DMH 1047	RIM ELEV.=12.6'	(1047) 12" CLAY INV.=6.2'	
(1045) 12" CLAY INV.=10.1'		(A) 12" CLAY INV.=6.2'	
(1056) 12" CLAY INV.=8.9'		CB 1103	RIM ELEV.=10.9'
(A) 12" CLAY INV.=4.8'		(OUTFALL) 8" CLAY W/FES INV.=6.1'	
(1059) 12" CLAY INV.=0.3'		SUMP ELEV.=5.4'	

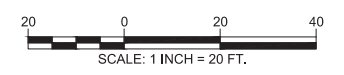

EXISTING CONDITIONS PLAN
FOR
HOYLE, TANNER & ASSOCIATES, INC
OF
NHDOT BRIDGE NO. 231/103
MAPLEWOOD AVENUE
PORTSMOUTH, NEW HAMPSHIRE

NO.	DATE	DESCRIPTION	BY

DRAWN BY:	W.D.C.	DATE:	FEBRUARY 17, 2020
CHECKED BY:	M.W.F.	DRAWING NO.	6032A
JOB NO.	6032	SHEET	3 OF 3

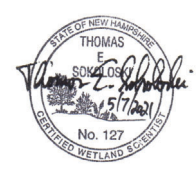

DOUCET SURVEY
Serving Your Professional Surveying & Mapping Needs
102 Kent Place, Newmarket, NH 03857 (603) 659-8560
2 Commerce Drive (Suite 202) Bedford, NH 03110 (603) 614-4060
10 Storer Street (Riverview Suite) Kennebunk, ME (207) 502-7005
http://www.doucetsurvey.com

FILE NAME: \\P:\PROJECTS\6032A_CAD\DWG\6032A.dwg DATE: 02/17/2020 10:57:00 AM PLOT DATE: 02/17/2020 10:57:00 AM PLOT SCALE: 1"=20'

SPRINGBROOK CONDOMINIUM ASSOCIATION
2000 Springbrook Circle
Portsmouth, NH 03801
603.610.0165
www.springbrookcondos.com

September 26, 2023

Samantha Collins, Chair
Conservation Commission
1 Junkins Avenue
Portsmouth, NH 03801

RE: O Springbrook Circle, LU-23-157

Dear Samantha Collins,

I wish to explain the background for the proposed new walkway by the Springbrook Condominium Association and our understanding of conservation impacts. Springbrook is situated on 84.6 acres, less than half of which is developed. Behind the pond there are 32.7 acres of designated conservation area which includes a portion of Berry's Brook watershed. The back of our property abuts property on Wallis Road in Rye. There are approximately 3300 feet of pond bank, much of which provide a natural habitat for wildlife.

Springbrook has a parking issue with lot #6 that is located between buildings 5 and 6. It is one of the smaller lots when it was designed in the mid 1980's. There are 20 units (building 5 and building 6) that utilize this lot, and that represents a possibility of 40 cars (2 per unit). This parking lot can only accommodate about 70% of this demand. In the past, not all unit owners or tenants had 2 cars so there were no major issues regarding parking. There is no way to expand this parking lot as it also abuts the pond and is in the Inland Wetland Buffer as well.

The Board of Directors has proposed the current plan that is less evasive to the Inland Wetland Buffer. The area that will be impacted is 870 square feet – a 5' wide walkway 174' long. The walkway begins at the back of parking lot number 5 (designated an overflow lot) and runs along the side of units 508 and 516 then curves to the left and connects with the existing walkway that serves units 513 to 516. This will allow those units, as well as others, access to available parking in lot #5 and lessen the impact of lot #6.

Once the project is approved and completed, the Board of Directors intends to install some new plantings around Building 5 as well as some additional plantings adjacent to the walkway to offset possible impacts from the impervious surface created by the new walkway.

Sincerely,

David S. Wajda, President

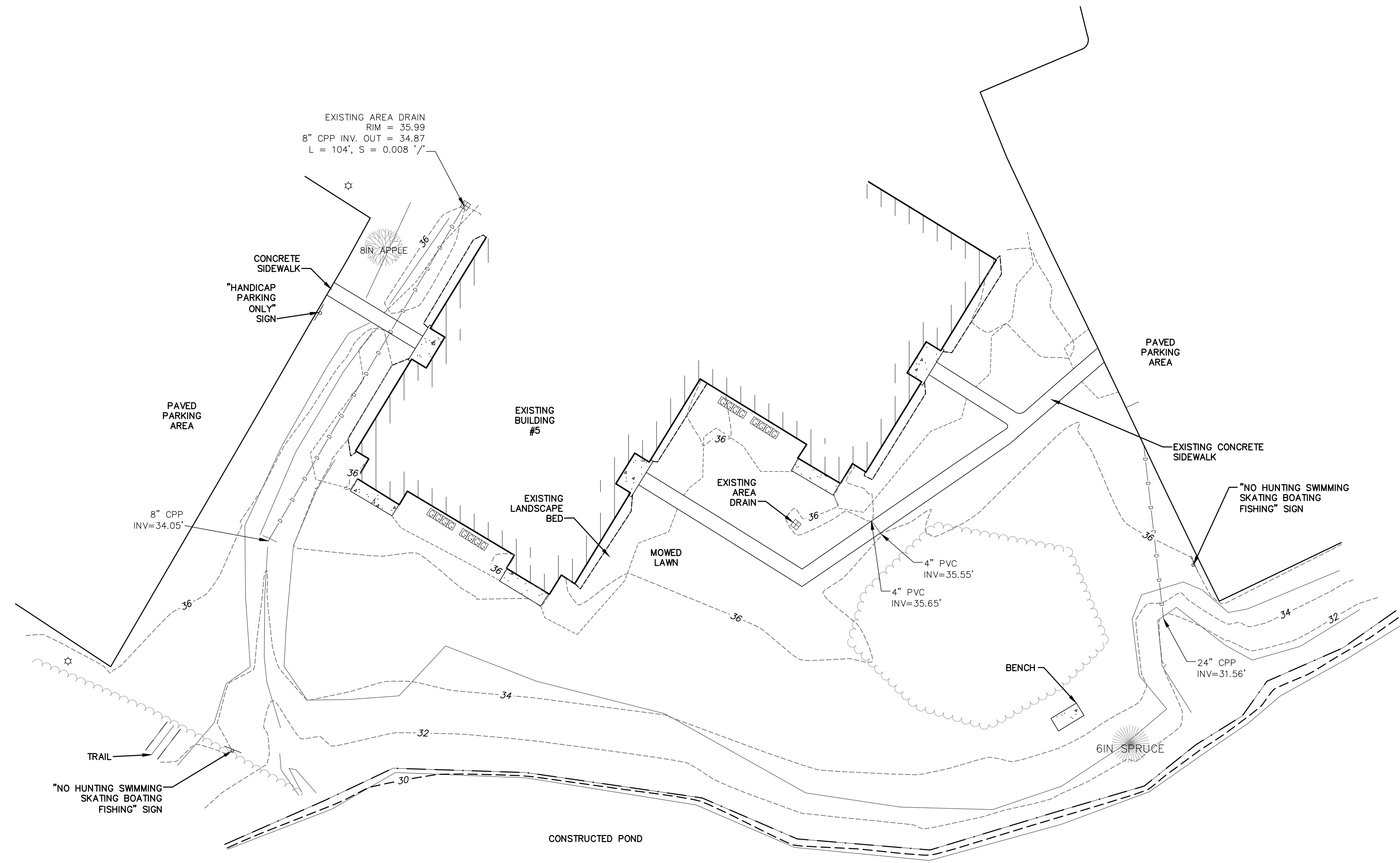
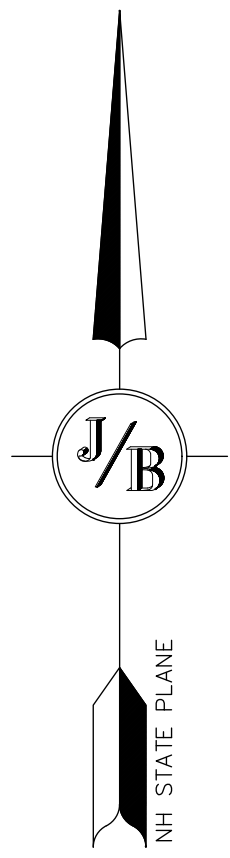
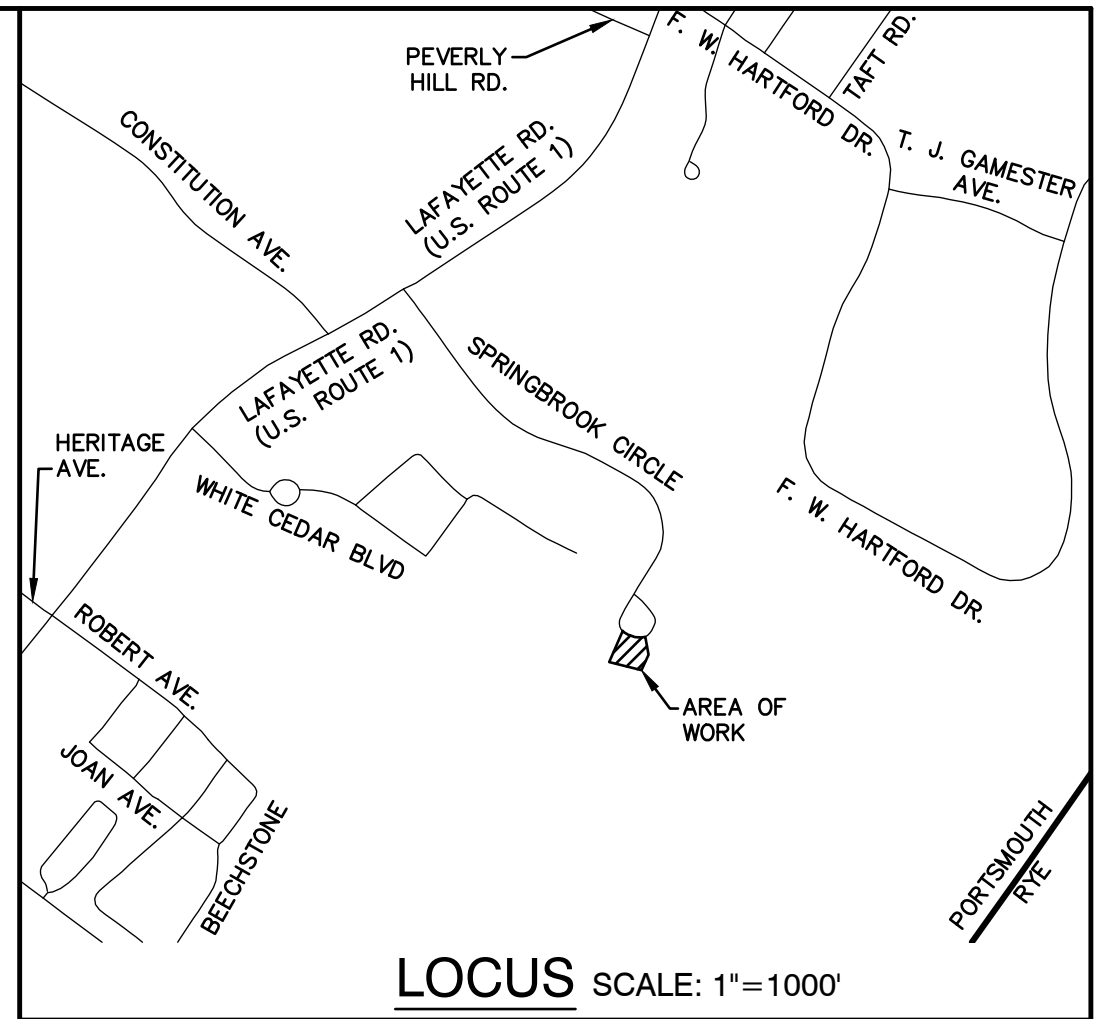

NOTES:

1. THE INTENT OF THIS PLAN IS TO SHOW THE EXISTING CONDITIONS FOR SOME OF THE AREA AROUND BUILDING #5 OF SPRINGBROOK CONDOMINIUMS.
2. THE UTILITY LOCATIONS SHOWN HEREON WERE DETERMINED BY OBSERVED ABOVE GROUND EVIDENCE AND SHOULD BE CONSIDERED APPROXIMATE IN LOCATION ONLY. LOCATION, DEPTH, SIZE, TYPE, EXISTENCE OR NONEXISTENCE OF UNDERGROUND UTILITIES AND/OR UNDERGROUND STORAGE TANKS WAS NOT VERIFIED BY THIS SURVEY. ALL CONTRACTORS SHOULD NOTIFY IN WRITING ALL UTILITY COMPANIES AND GOVERNMENT AGENCIES PRIOR TO ANY EXCAVATION WORK OR CALL DIG-SAFE AT 1-888-DIG-SAFE.
3. BASIS OF BEARING: HORIZONTAL - NH STATE PLANE. VERTICAL - NAVD88.
4. CERTAIN DATA HEREON MAY VARY FROM RECORDED DATA DUE TO DIFFERENCES IN DECLINATION, ORIENTATION, AND METHODS OF MEASUREMENT.
5. THE TAX MAP AND LOT NUMBERS ARE BASED ON THE CITY OF PORTSMOUTH TAX RECORDS AND ARE SUBJECT TO CHANGE.
6. RESEARCH WAS PERFORMED AT THE CITY OF PORTSMOUTH ASSESSOR'S OFFICE AND THE ROCKINGHAM COUNTY REGISTRY OF DEEDS.
7. THIS PLAN IS NOT A BOUNDARY SURVEY.
8. NO WETLAND DELINEATION WAS PERFORMED AS A PART OF THIS SURVEY.
9. THIS PLAN IS THE RESULT OF A CLOSED TRAVERSE WITH A RAW, UNADJUSTED LINEAR ERROR OF CLOSURE GREATER THAN 1 IN 82,000.

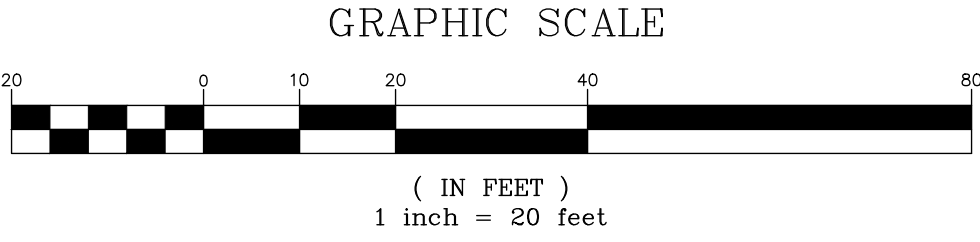

PROJECT PARCEL
TOWN OF PORTSMOUTH
TAX MAP 272, LOT 6

Design: DJM	Draft: DJM	Date: 10/19/22
Checked: BAJ	Scale: AS SHOWN	Project No.: 11046
Drawing Name: 11046-PLAN.dwg		
THIS PLAN SHALL NOT BE MODIFIED WITHOUT WRITTEN PERMISSION FROM JONES & BEACH ENGINEERS, INC. (JBE). ANY ALTERATIONS, AUTHORIZED OR OTHERWISE, SHALL BE AT THE USER'S SOLE RISK AND WITHOUT LIABILITY TO JBE.		

REV.	DATE	REVISION	BY
1	2/27/23	REVISED PER CLIENT	DJM
0	10/19/22	ISSUED FOR REVIEW	DJM

Designed and Produced in NH

J/B Jones & Beach Engineers, Inc.

85 Portsmouth Ave. *Civil Engineering Services* 603-772-4746
 PO Box 219 Stratham, NH 03885 FAX: 603-772-0227
 E-MAIL: JBE@JONESANDBEACH.COM

Plan Name:	EXISTING CONDITIONS PLAN
Project:	SIDEWALK CONSTRUCTION PLAN SPRINGBROOK CIRCLE, PORTSMOUTH, NH
Owner of Record:	SPRINGBROOK CONDOMINIUM ASSOCIATION 2000 SPRINGBROOK CIRCLE, PORTSMOUTH, NH 03801

DRAWING No.	C1
SHEET 1 OF 2	
JBE PROJECT NO. 11046	

GRADING AND DRAINAGE NOTES:

- UNDERGROUND FACILITIES, UTILITIES AND STRUCTURES HAVE BEEN PLOTTED FROM FIELD OBSERVATION AND THEIR LOCATION MUST BE CONSIDERED APPROXIMATE ONLY. NEITHER JONES & BEACH ENGINEERS, INC. NOR ANY OF THEIR EMPLOYEES TAKE RESPONSIBILITY FOR THE LOCATION OF ANY UNDERGROUND STRUCTURES AND/OR UTILITIES NOT SHOWN THAT MAY EXIST. IT IS THE RESPONSIBILITY OF THE CONTRACTOR TO HAVE ALL UNDERGROUND STRUCTURES AND/OR UTILITIES LOCATED PRIOR TO EXCAVATION WORK BY CALLING 888-DIG-SAFE (888-344-7233).
- VERTICAL DATUM: NAVD88. HORIZONTAL DATUM: NH STATE PLANE.
- SITE GRADING SHALL NOT PROCEED UNTIL EROSION CONTROL MEASURES HAVE BEEN INSTALLED.
- PRIOR TO THE START OF CONSTRUCTION, THE CONTRACTOR IS REQUIRED TO HAVE THE PROJECT'S LAND SURVEYOR STAKE OR FLAG CLEARING LIMITS. A MINIMUM OF 48 HOURS NOTICE IS REQUIRED.
- PROPOSED RIM ELEVATIONS OF DRAINAGE STRUCTURES ARE APPROXIMATE. FINAL ELEVATIONS ARE TO BE SET FLUSH WITH FINISH GRADES.
- ALL DRAINAGE AND SANITARY STRUCTURE INTERIOR DIAMETERS (4" MIN) SHALL BE DETERMINED BY THE MANUFACTURER BASED ON THE PIPE CONFIGURATIONS SHOWN ON THESE PLANS. CATCH BASINS SHALL HAVE 3' DEEP SUMPS WITH GREASE HOODS, UNLESS OTHERWISE NOTED.
- ALL DRAINAGE STRUCTURES SHALL BE PRECAST, UNLESS OTHERWISE SPECIFIED.
- ALL DRAINAGE PIPE SHALL BE NON-PERFORATED ADS N-12 OR APPROVED EQUAL.
- STONE INLET PROTECTION SHALL BE PLACED AT ALL CATCH BASINS. SEE DETAIL WITHIN THE DETAIL SHEETS.
- ALL EXPOSED AREAS SHALL BE SEEDED AS SPECIFIED WITHIN 3 DAYS OF FINAL GRADING AND ANYTIME CONSTRUCTION STOPS FOR LONGER THAN 3 DAYS.
- THIS PLAN SHALL NOT BE CONSIDERED ALL INCLUSIVE, AS THE GENERAL CONTRACTOR SHALL TAKE ALL NECESSARY PRECAUTIONS TO PREVENT SEDIMENT FROM LEAVING THE SITE.
- THE GENERAL CONTRACTOR SHALL BE RESPONSIBLE TO TAKE WHATEVER MEANS NECESSARY TO ESTABLISH PERMANENT SOIL STABILIZATION.
- ALL WORK SHALL BE DONE IN STRICT ACCORDANCE WITH PROJECT SPECIFICATIONS.
- ADDITIONAL EROSION AND SEDIMENT CONTROL MEASURES SHALL BE INSTALLED, IF DEEMED NECESSARY BY ON-SITE INSPECTION BY ENGINEER AND/OR REGULATORY OFFICIALS.
- LOAM AND SEED ALL DISTURBED AREAS.

SITE NOTES:

- THE INTENT OF THIS PLAN IS TO CONSTRUCT A CONCRETE SIDEWALK ON THE SUBJECT PARCEL.
- THIS PLAN SET HAS BEEN PREPARED BY JONES & BEACH ENGINEERS, INC., FOR MUNICIPAL AND STATE APPROVALS AND FOR CONSTRUCTION BASED ON DATA OBTAINED FROM ON-SITE FIELD SURVEY AND EXISTING MUNICIPAL RECORDS. THROUGHOUT THE CONSTRUCTION PROCESS, THE CONTRACTOR SHALL INFORM THE ENGINEER IMMEDIATELY OF ANY FIELD DISCREPANCY FROM DATA AS SHOWN ON THE DESIGN PLANS, INCLUDING ANY UNFORESEEN CONDITIONS, SUBSURFACE OR OTHERWISE, FOR EVALUATION AND RECOMMENDATIONS. ANY CONTRADICTION BETWEEN ITEMS ON THIS PLAN/PLAN SET, OR BETWEEN THE PLANS AND ON-SITE CONDITIONS, MUST BE RESOLVED BEFORE RELATED CONSTRUCTION HAS BEEN INITIATED. CONTRACTOR TO ALWAYS CONTACT DIG SAFE PRIOR TO DIGGING ONSITE OR OFFSITE TO ENSURE SAFETY AND OBEY THE LAW.
- ALL CONSTRUCTION SHALL CONFORM TO TOWN STANDARDS AND REGULATIONS, AND NHDOT STANDARD SPECIFICATIONS FOR ROAD AND BRIDGE CONSTRUCTION, WHICHEVER IS MORE STRINGENT.
- LANDOWNERS ARE RESPONSIBLE FOR COMPLYING WITH ALL APPLICABLE LOCAL, STATE AND FEDERAL WETLAND REGULATIONS, INCLUDING PERMITTING REQUIRED UNDER THESE REGULATIONS.
- PRIOR TO THE START OF CONSTRUCTION, THE CONTRACTOR SHALL COORDINATE WITH THE ENGINEER, ARCHITECT AND/OR OWNER, IN ORDER TO OBTAIN AND/OR PAY ALL THE NECESSARY LOCAL PERMITS, FEES AND BONDS.
- ALL CONSTRUCTION ACTIVITIES SHALL CONFORM TO LABOR OCCUPATIONAL SAFETY AND HEALTH ADMINISTRATION (OSHA) RULES AND REGULATIONS.
- ALL PRECAST CONCRETE PRODUCTS WILL BE SOURCED FROM MANUFACTURING FACILITIES IN COMPLIANCE WITH THE NATIONAL PRECAST CONCRETE ASSOCIATION (NPCA) PLANT CERTIFICATION PROGRAM. EVIDENCE OF COMPLIANCE WILL BE PROVIDED FOR THE CURRENT CALENDAR YEAR THE PRODUCTS WERE MANUFACTURED WITHIN.

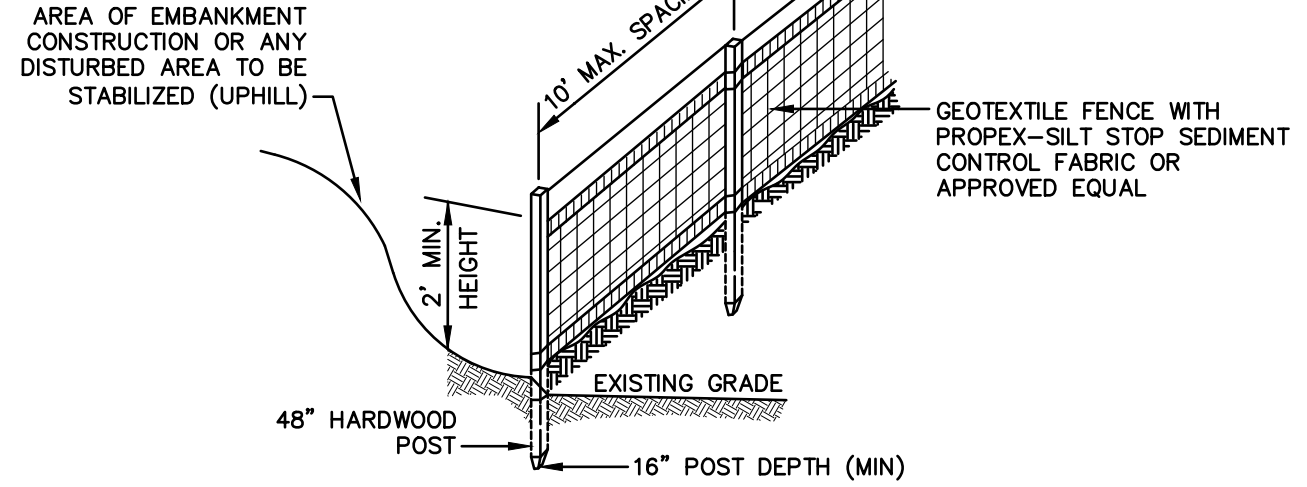

CONSTRUCTION SPECIFICATIONS:

- WOVEN FABRIC FENCE TO BE FASTENED SECURELY TO FENCE POSTS WITH WIRE TIES OR STAPLES. FILTER CLOTH SHALL BE FASTENED TO WOVEN WIRE EVERY 24" AT TOP, MID AND BOTTOM AND EMBEDDED IN THE GROUND A MINIMUM OF 8" AND THEN COVERED WITH SOIL.
- THE FENCE POSTS SHALL BE A MINIMUM OF 48" LONG, SPACED A MAXIMUM 10' APART, AND DRIVEN A MINIMUM OF 16" INTO THE GROUND.
- WHEN TWO SECTIONS OF FILTER CLOTH ADJOIN EACH OTHER, THE ENDS OF THE FABRIC SHALL BE OVERLAPPED 6", FOLDED AND STAPLED TO PREVENT SEDIMENT FROM BY-PASSING.
- MAINTENANCE SHALL BE PERFORMED AS NEEDED AND SEDIMENT REMOVED AND PROPERLY DISPOSED OF WHEN IT IS 6" DEEP OR VISIBLE 'BULGES' DEVELOP IN THE SILT FENCE.
- PLACE THE ENDS OF THE SILT FENCE UP CONTOUR TO PROVIDE FOR SEDIMENT STORAGE.
- SILT FENCE SHALL REMAIN IN PLACE FOR 24 MONTHS.

SILT FENCE

NOT TO SCALE

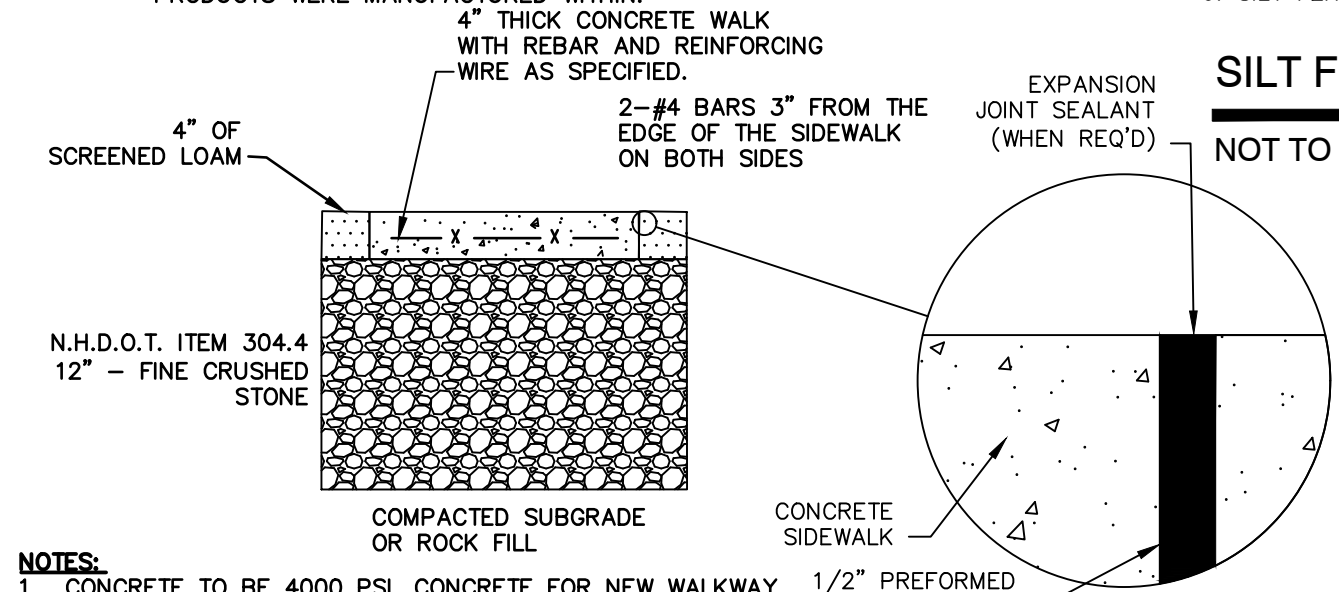

NOTES:

- CONCRETE TO BE 4000 PSI. CONCRETE FOR NEW WALKWAY 1/2" PREFORMED SHALL BE A STATE OF NEW HAMPSHIRE BRIDGE DECK MIX AND SHALL CONFORM TO THE LATEST ACI CODE AND DESIGN MIX SPECIFICATIONS.
- CONTRACTION JOINTS SPACE TO BE EQUAL TO SIDEWALK WIDTH.
- ALL JOINTS SEALED PER SPECIFICATIONS.
- PROVIDE A 1/2" NON-EXTRUDING EXPANSION JOINT AGAINST STRUCTURE AND EVERY 16' ALONG SIDEWALK.
- STEEL REBAR SPECIFICATION: #4 BARS CONFORMING TO ASTM A615-GR60 REQUIREMENTS OR MOST CURRENT.
- PROVIDE BROOM FINISH IN DIRECTION PERPENDICULAR TO PARKING LOT.
- REINFORCING WIRE SHALL BE 6x6x#10 WIRE CONFORMING TO ASTM A185 REQUIREMENTS OR MOST CURRENT.
- ALL CONSTRUCTION JOINTS TO BE DOWELED AND SLEEVED.

CONCRETE SIDEWALK

NOT TO SCALE

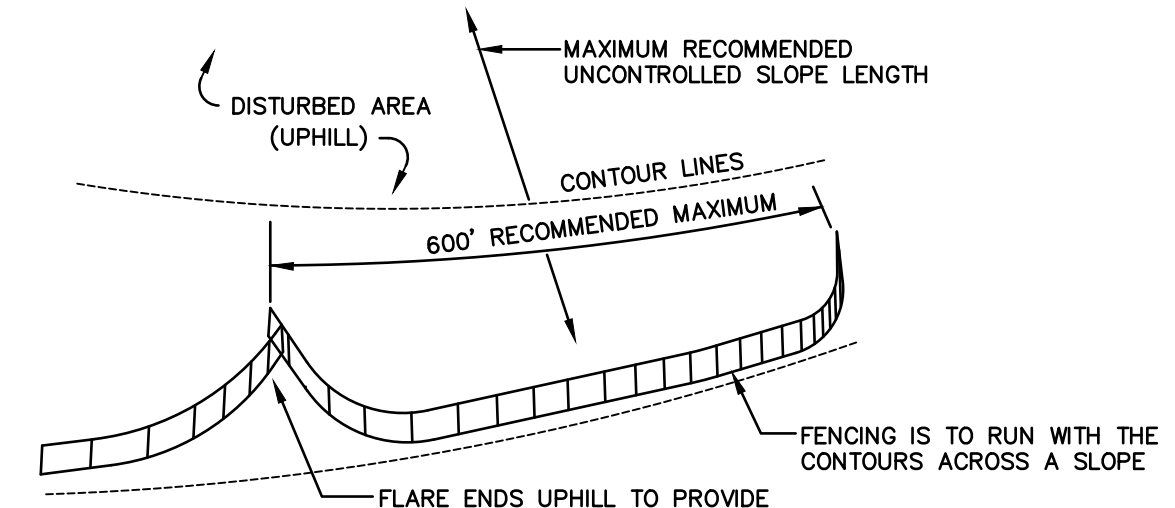
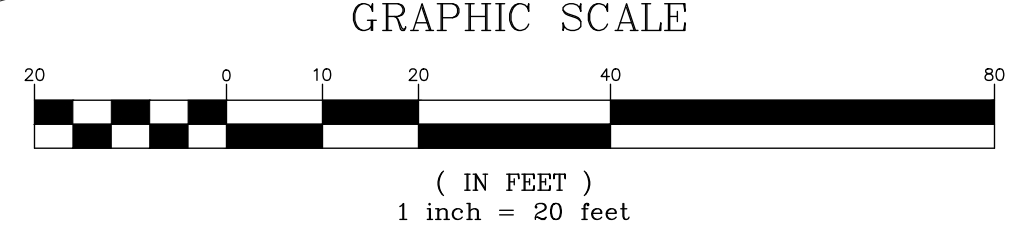
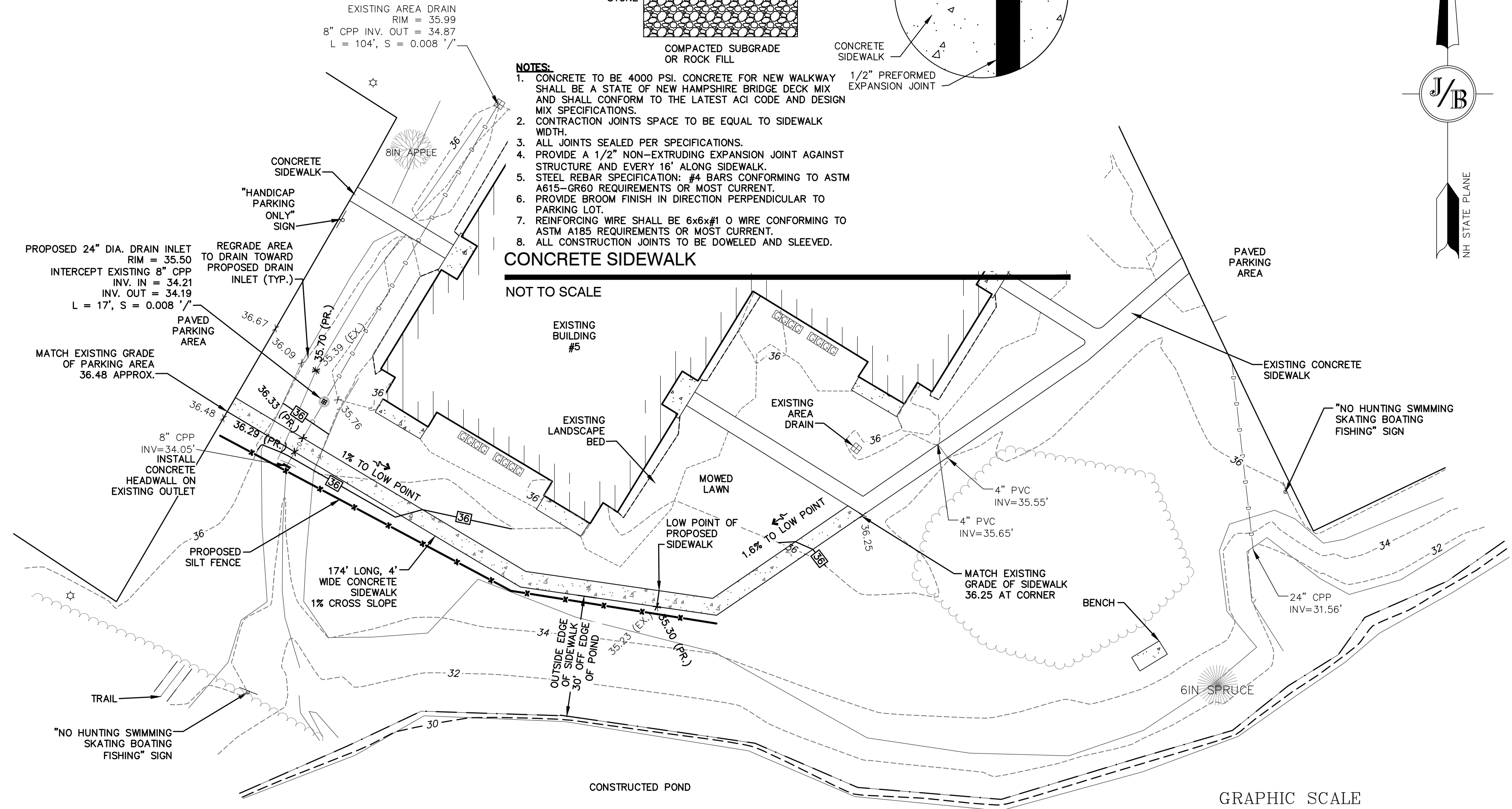

MAINTENANCE:

- SILT FENCES SHALL BE INSPECTED IMMEDIATELY AFTER EACH RAINFALL AND AT LEAST DAILY DURING PROLONGED RAINFALL. ANY REPAIRS THAT ARE REQUIRED SHALL BE DONE IMMEDIATELY.
- IF THE FABRIC ON A SILT FENCE SHOULD DECOMPOSE OR BECOME INEFFECTIVE DURING THE EXPECTED LIFE OF THE FENCE, THE FABRIC SHALL BE REPLACED PROMPTLY.
- SEDIMENT DEPOSITS SHOULD BE INSPECTED AFTER EVERY STORM EVENT. THE DEPOSITS SHOULD BE REMOVED WHEN THEY REACH APPROXIMATELY ONE HALF THE HEIGHT OF THE BARRIER.
- SEDIMENT DEPOSITS THAT ARE REMOVED, OR LEFT IN PLACE AFTER THE FABRIC HAS BEEN REMOVED, SHALL BE GRADED TO CONFORM WITH THE EXISTING TOPOGRAPHY AND VEGETATED.

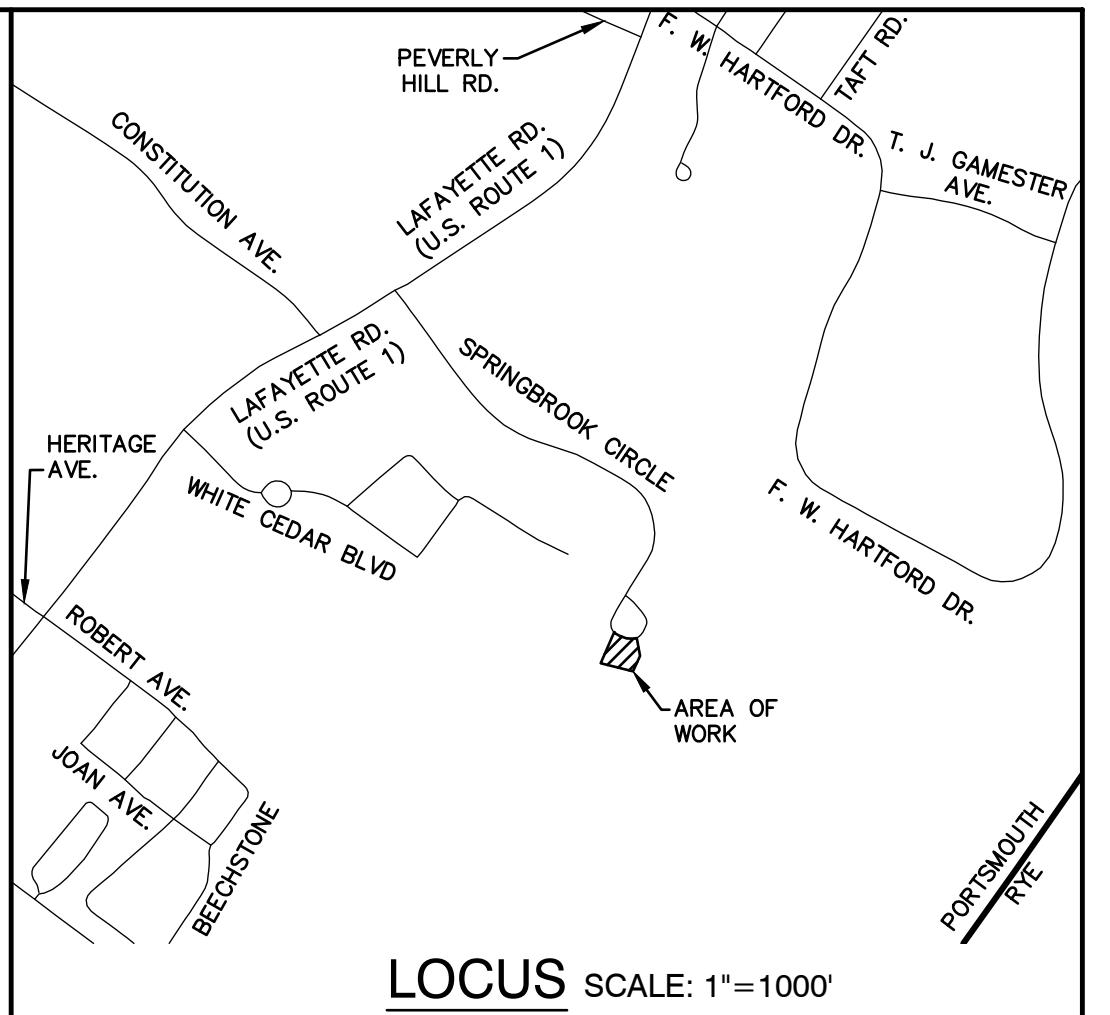

LOCUS SCALE: 1"=1000'

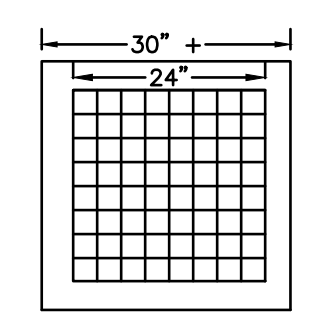

PLAN VIEW NOT TO SCALE

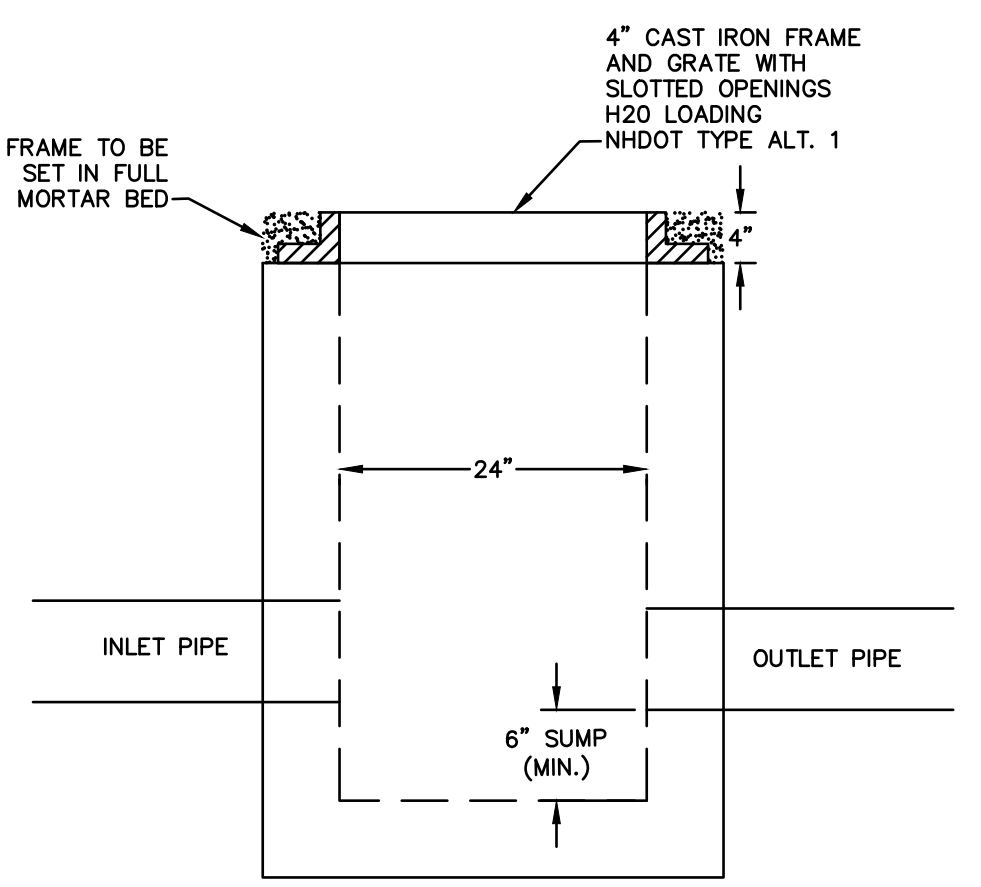

SQUARE DRAIN INLET

NOT TO SCALE

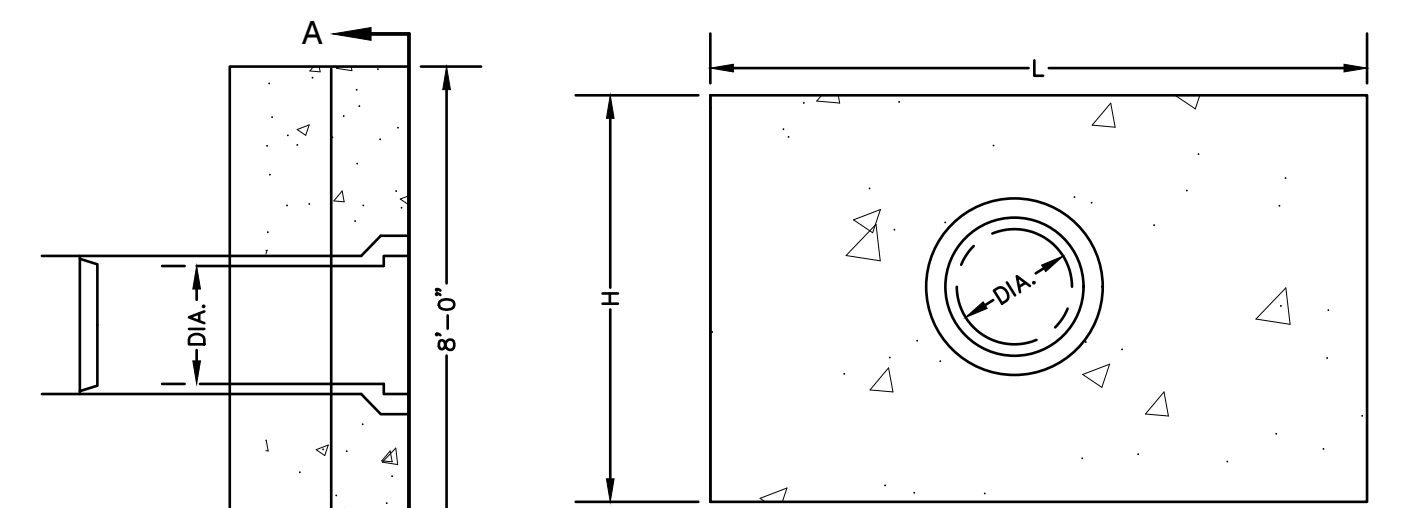

SECTION A-A

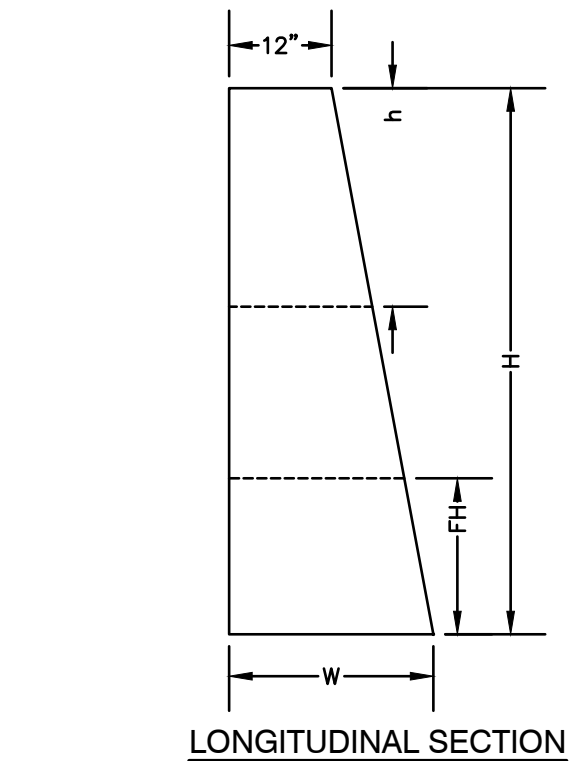

LONGITUDINAL SECTION

DIA.	HEADWALL LENGTH	HEADWALL HEIGHT	FILL HEIGHT	PIPE COVER	HEADWALL BOTTOM WIDTH
D	L	H	FH	h	W
8"	2'-0"	1'-6"	0'-6"	0'-3"	0'-6"
12"	4'-2"	3'-9"	1'-6"	1'-3"	1'-11"
15"	5'-11"	4'-2"	1'-6"	1'-5"	2'-0"
18"	6'-11"	4'-5"	1'-6"	1'-5"	2'-1"
24"	8'-10"	4'-11"	1'-6"	1'-5"	2'-3"

* = PER MANUFACTURER

NOTES:

- ALL DIMENSIONS GIVEN IN FEET & INCHES.
- PROVIDE BELL END AT INLET HEADWALL, AND SPIGOT END AT OUTLET END HEADWALL.
- CONCRETE: 5,000 PSI MINIMUM AFTER 28 DAYS. CEMENT TO BE TYPE III PER ASTM C-150. REINFORCING TO MEET OR EXCEED ASTM A-615 GRADE 60 DEFORMED BARS.
- 1" THREADED INSERTS PROVIDED FOR FINAL ATTACHMENT IN FIELD BY OTHERS.

PRECAST CONCRETE HEADWALL

NOT TO SCALE

Design: DJM	Draft: DJM	Date: 10/19/22
Checked: BAJ	Scale: AS SHOWN	Project No.: 11046
Drawing Name: 11046-PLAN.dwg		
THIS PLAN SHALL NOT BE MODIFIED WITHOUT WRITTEN PERMISSION FROM JONES & BEACH ENGINEERS, INC. (JBE). ANY ALTERATIONS, AUTHORIZED OR OTHERWISE, SHALL BE AT THE USER'S SOLE RISK AND WITHOUT LIABILITY TO JBE.		

REV.	DATE	REVISION	BY
1	2/27/23	REVISED PER CLIENT	DJM
0	10/19/22	ISSUED FOR REVIEW	DJM

Designed and Produced in NH

J/B Jones & Beach Engineers, Inc.

Civil Engineering Services

85 Portsmouth Ave. Stratham, NH 03885 603-772-4746 FAX: 603-772-0227 E-MAIL: JBE@JONESANDBEACH.COM

Plan Name:	SIDEWALK CONSTRUCTION PLAN
Project:	SIDEWALK CONSTRUCTION PLAN SPRINGBROOK CIRCLE, PORTSMOUTH, NH
Owner of Record:	SPRINGBROOK CONDOMINIUM ASSOCIATION 2000 SPRINGBROOK CIRCLE, PORTSMOUTH, NH 03801

DRAWING No.

C2

SHEET 2 OF 2
JBE PROJECT NO. 11046

M-5131-001
September 5, 2023

Ms. Samantha Collins, Chair
City of Portsmouth Conservation Commission
1 Junkins Avenue
Portsmouth, New Hampshire 03801

Re: **Request for Conservation Commission Work Session
815 Lafayette Road - Proposed Development**

Dear Chair Collins:

On behalf of Prospect North LLC (owner/applicant) we are pleased to submit the following information to support a request for a Work Session with the Conservation Commission for the above referenced project:

- Site Plan Set, dated September 5, 2023;
- Wetland Buffer Impervious Surface Exhibit, dated September 5, 2023
- Community Space Exhibit, dated September 5, 2023;
- Owners Authorization, dated June 1, 2023;

The proposed project is located at 815 Lafayette Road (US Route 1) which is identified as Map 245 Lot 3 on the City of Portsmouth Tax Maps. The site was previously home to the WHEB radio station which no longer operates at this location. The property is a 19.6-acre parcel of land that is located in the Gateway District (G1). The property is bound to the west by Route 1 and the abutting Lafayette Plaza shopping center property, to the north and east by the Winchester Place property and to the south by Sagamore Creek.

The proposed project consists of the demolition of the existing building along Sagamore Creek and the construction of three 4-story, 24-unit multi-family buildings (72 total units) with first floor parking. The project will include associated site improvements such as parking, pedestrian access, utilities, stormwater management, lighting, and landscaping.

As currently designed, this project would require a Conditional Use Permit (CUP) for improvements within the 100-foot wetland buffer. In addition, the project will require relief from the Zoning Board of Adjustment (ZBA) for efforts to develop the front lot line within the limits of the usable front yard. As such, we are seeking to meet with the Conservation Commission for a Work Session to obtain initial feedback on the proposed development in advance of formally submitting the various land-use applications that will be required for this project.

The proposed parking and buildings have been situated in a manner such that all impervious surfaces will be removed within 25-feet of Sagamore Creek and all buildings will be removed within 100-feet of Sagamore Creek. Overall, the current design will reduce impervious surface within the 100-foot buffer by approximately 9,600 SF and will enhance water quality with the addition of stormwater treatment practices that do not currently exist on the site. In addition to removing pavement that goes right up to the edge of the brook, the proposed development identifies opportunities for buffer enhancement along the wetland.

On behalf of the applicant, we respectfully request to be placed on the September 13, 2023, Conservation Commission meeting agenda for a Work Session.



If you have any questions or need any additional information, please contact me by phone at (603) 433-8818 or by email at NAHansen@tighebond.com.

Sincerely,
TIGHE & BOND, INC.



Patrick M. Crimmins, PE
Vice President

Copy: Prospect North 815, LLC



Neil A. Hansen, PE
Project Manager

815 LAFAYETTE ROAD PROPOSED DEVELOPMENT

PORTSMOUTH, NEW HAMPSHIRE

DATE SEPTEMBER 5, 2023

PROGRESS PRINT

LIST OF DRAWINGS		
SHEET NO.	SHEET TITLE	LAST REVISED
	COVER SHEET	9/5/2023
C1	EXISTING CONDITIONS PLAN	2/2/2023
C2	EXISTING CONDITIONS PLAN	2/2/2023
C3	EXISTING CONDITIONS PLAN	2/2/2023
C4	EXISTING CONDITIONS PLAN	2/2/2023
C5	EXISTING CONDITIONS PLAN	2/2/2023
G-100	GENERAL NOTES AND LEGEND	9/5/2023
C-101	DEMOLITION PLAN	9/5/2023
C-102	SITE PLAN	9/5/2023
C-103	GRADING, DRAINAGE, AND EROSION CONTROL PLAN	9/5/2023
C-104	UTILITY PLAN	9/5/2023
C-501	EROSION CONTROL NOTES AND DETAILS SHEET	9/5/2023
C-502	DETAILS SHEET	9/5/2023
C-503	DETAILS SHEET	9/5/2023
C-504	DETAILS SHEET	9/5/2023
C-505	DETAILS SHEET	9/5/2023
1 OF 2	BUILDING ELEVATIONS	8/29/2023
2 OF 2	TYPICAL FLOOR PLANS	8/29/2023

LIST OF PERMITS		
LOCAL	STATUS	DATE
SITE PLAN REVIEW PERMIT	PENDING	
CONDITIONAL USE PERMIT - WETLAND BUFFER	PENDING	
ZONING BOARD OF ADJUSTMENTS	PENDING	
STATE		
NHDES - SEWER CONNECTION PERMIT	NOT SUBMITTED	
NHDES - ALTERATION OF TERRAIN PERMIT	NOT SUBMITTED	

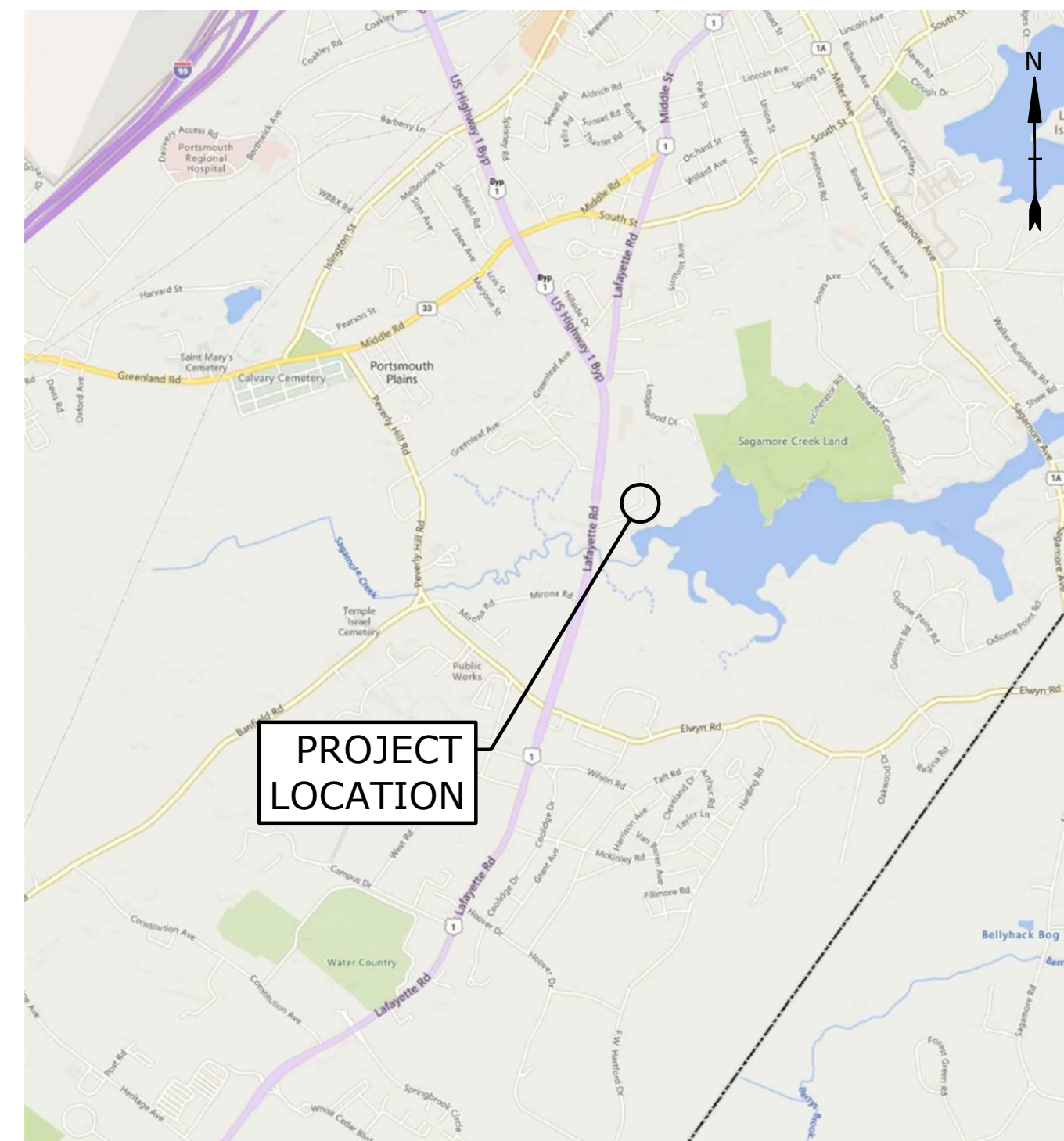

LOCATION MAP
SCALE: 1" = 2000'

CONSTRUCTION NOTES:

1. THE CONTRACTOR SHALL NOT RELY ON SCALED DIMENSIONS AND SHALL CONTACT THE ENGINEER FOR CLARIFICATION IF A REQUIRED DIMENSION IS NOT PROVIDED ON THE PLANS.
2. THE CONTRACTOR SHALL BE RESPONSIBLE FOR CONSTRUCTION MEANS AND METHODS, AND FOR SITE CONDITIONS THROUGHOUT CONSTRUCTION. NEITHER THE PLANS NOR THE SEAL OF THE ENGINEER AFFIXED HEREON EXTEND TO OR INCLUDE SYSTEMS REQUIRED FOR THE SAFETY OF THE CONTRACTOR, THEIR EMPLOYEES, AGENTS OR REPRESENTATIVES IN THE PERFORMANCE OF THE WORK. THE CONTRACTOR SHALL BE RESPONSIBLE FOR DETERMINING AND IMPLEMENTING SAFETY PROCEDURES AND SYSTEMS AS REQUIRED BY THE UNITED STATES OCCUPATIONAL SAFETY AND HEALTH ADMINISTRATION (OSHA), AND ANY STATE OR LOCAL SAFETY REGULATIONS.
3. TIGHE & BOND ASSUMES NO RESPONSIBILITY FOR ANY ISSUES LEGAL OR OTHERWISE, RESULTING FROM CHANGES MADE TO THESE DRAWINGS WITHOUT WRITTEN AUTHORIZATION OF TIGHE & BOND.

PREPARED BY:

Tighe & Bond

177 CORPORATE DRIVE
PORTSMOUTH, NH 03801
603-433-8818

APPLICANT:

PROSPECT NORTH 815, LLC
PO Box 372
Greenland, NH 04840

ARCHITECT:

MICHAEL J. KEANE ARCHITECTS, PLLC
101 Kent Place
Newmarket, NH 03857

SURVEYOR:

AMBIT ENGINEERING, INC.
200 Griffin Road - Unit 3
Portsmouth, NH 03801



**TAC WORK SESSION SUBMISSION
COMPLETE SET 18 SHEETS**



LOCATION MAP SCALE: 1"=500'

LEGEND:

- N/F NOW OR FORMERLY
- RP RECORD OF PROBATE
- RCRD ROCKINGHAM COUNTY REGISTRY OF DEEDS
- (17/21) MAP 11 / LOT 21
- BOUNDARY
- - - SETBACK
- HOTL HIGHEST OBSERVABLE TIDE LINE
- RAILROAD SPIKE FOUND
- IRON ROD/PIPE FOUND
- ⊙ DRILL HOLE FOUND
- ⊙ STONE/CONCRETE BOUND FOUND
- ⊙ RAILROAD SPIKE SET
- ⊙ IRON ROD SET
- ⊙ DRILL HOLE SET
- ⊙ GRANITE BOUND SET
- EDGE OF PAVEMENT (EP)
- UNDERGROUND ELECTRIC
- OVERHEAD ELECTRIC/WIRES
- CONTOUR
- WOODS / TREE LINE
- ⊙ WATER SHUT OFF/CURB STOP
- ⊙ GAS SHUT OFF/CURB STOP
- ⊙ WGV WATER GATE VALVE
- ⊙ GCY GAS GATE VALVE
- ⊙ UTY UTILITY POLE (w/ GUY)
- ⊙ METER (GAS, WATER, ELECTRIC)
- ⊙ CATCH BASIN
- ⊙ ELECTRIC MANHOLE
- ⊙ SEWER MANHOLE
- ⊙ TELEPHONE/COMMUNICATIONS MANHOLE
- ⊙ LIGHTPOLE
- ⊙ SIGNS
- TYP. TYPICAL
- LSA LANDSCAPED AREA
- EHH ELECTRIC HANDHOLE
- MW MONITORING WELL
- TH THRESHOLD
- EL. ELEVATION
- TBM TEMPORARY BENCHMARK
- VGC VERTICAL GRANITE CURB
- BC BITUMINOUS CURB
- INV. INVERT
- .ORN ORNAMENTAL TREE

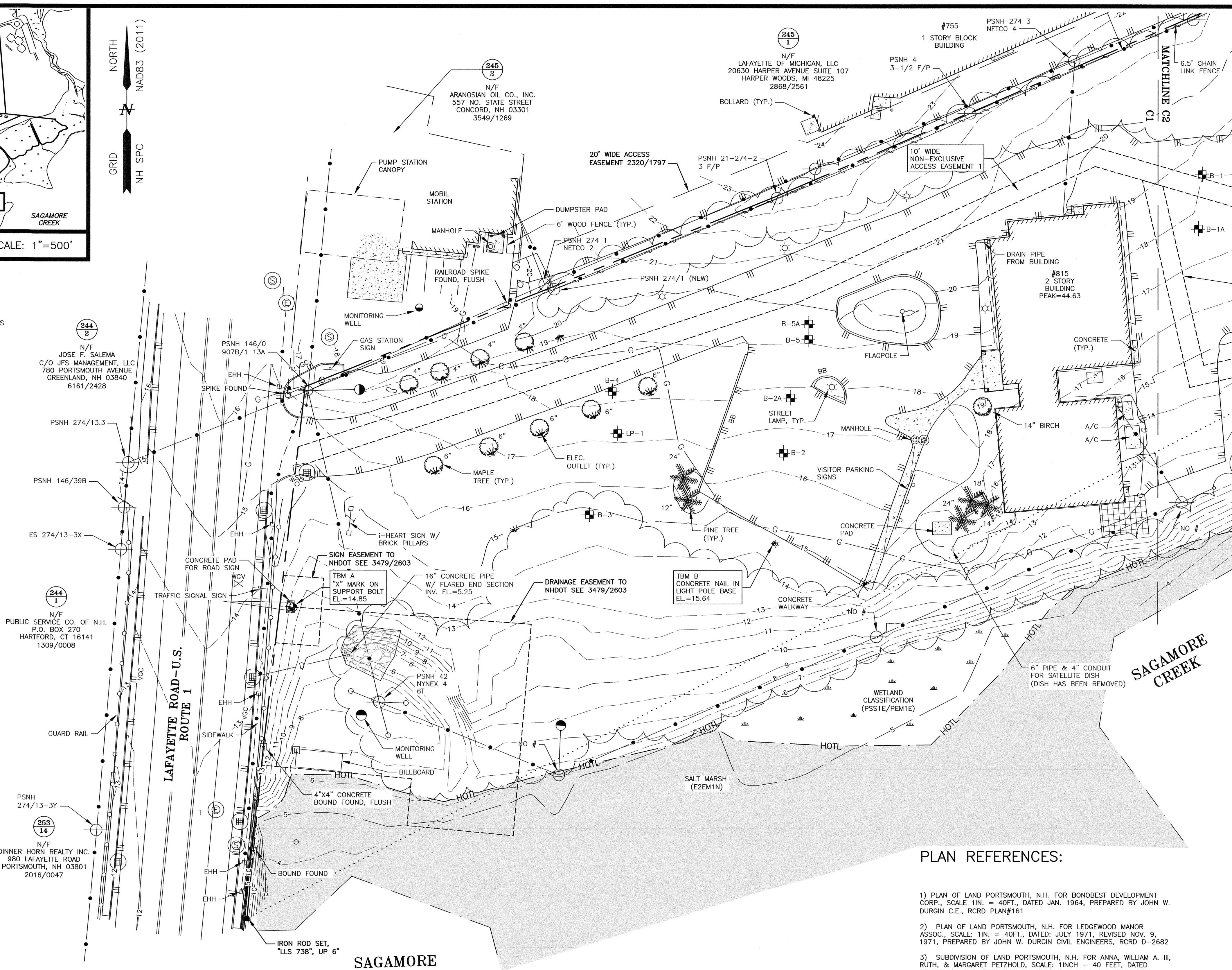

- NOTES:**
- 1) PARCELS ARE SHOWN ON THE CITY OF PORTSMOUTH ASSESSOR'S MAP 245 AS LOTS 3 AND 4.
 - 2) OWNER OF RECORD:
PROSPECT NORTH 815 LLC
PO BOX 372
GREENLAND, NH 03840
6443/665
 - 3) PARCEL IS PARTIALLY IN A SPECIAL FLOOD HAZARD AREA (ZONE AE) AS SHOWN ON FIRM PANEL 33015C0270F. EFFECTIVE DATE JANUARY 29, 2021.
 - 4) EXISTING LOT AREA:
MAP 245 LOT 3 855,562 S.F ± (TO MHW) 19.6410 AC ± (TO MHW)
MAP 245 LOT 4 19,948 S.F. 0.4579 ACRES
 - 5) PARCELS ARE LOCATED IN THE GATEWAY CORRIDOR (G1) ZONING DISTRICT.
 - 6) VERTICAL DATUM IS NAVD88. BASIS OF VERTICAL DATUM IS REDUNDANT RTN GNSS OBSERVATIONS.
 - 7) THE PURPOSE OF THIS PLAN IS TO SHOW THE RESULTS OF EXISTING CONDITIONS SURVEY OF ASSESSOR'S MAP 245 LOTS 3 & 4 IN THE CITY OF PORTSMOUTH.
 - 8) THE CONTRACTOR SHALL NOTIFY DIG SAFE AT 1-888-DIG-SAFE (1-888-344-7233) AT LEAST 72 HOURS PRIOR TO COMMENCING ANY EXCAVATION ON PUBLIC OR PRIVATE PROPERTY WITHIN 100 FEET OF UNDERGROUND UTILITIES. THE EXCAVATOR IS RESPONSIBLE TO MAINTAIN MARKS. DIG SAFE TICKETS EXPIRE IN THIRTY DAYS.
 - 9) UNDERGROUND UTILITY LOCATIONS ARE BASED UPON BEST AVAILABLE EVIDENCE AND ARE NOT FIELD VERIFIED. LOCATING AND PROTECTING ANY ABOVEGROUND OR UNDERGROUND UTILITIES IS THE SOLE RESPONSIBILITY OF THE CONTRACTOR AND/OR THE OWNER. UTILITY CONFLICTS SHOULD BE REPORTED AT ONCE TO THE DESIGN ENGINEER.
 - 10) CONTRACTOR SHALL INSTALL AND MAINTAIN EROSION CONTROL MEASURES IN ACCORDANCE WITH THE "NEW HAMPSHIRE STORMWATER MANUAL, VOLUME 3, EROSION AND SEDIMENT CONTROLS DURING CONSTRUCTION. (NHDES DECEMBER 2008).

**SITE DEVELOPMENT
815 LAFAYETTE ROAD
PORTSMOUTH, N.H.**

PLAN REFERENCES:

- 1) PLAN OF LAND PORTSMOUTH, N.H. FOR BONOBEST DEVELOPMENT CORP., SCALE 1/4" = 40FT., DATED JAN. 1964, PREPARED BY JOHN W. DURGIN C.E., RCRD PLAN#161
- 2) PLAN OF LAND PORTSMOUTH, N.H. FOR LEDGEWOOD MANOR ASSOC., SCALE: 1/4" = 40FT., DATED: JULY 1971, REVISED NOV. 9, 1971, PREPARED BY JOHN W. DURGIN CIVIL ENGINEERS, RCRD D-2682
- 3) SUBDIVISION OF LAND PORTSMOUTH, N.H. FOR ANNA, WILLIAM A. III, RUTH, & MARGARET PETZOLD, SCALE: 1/4" = 40 FEET, DATED DECEMBER 1977, PREPARED BY JOHN W. DURGIN CIVIL ENGINEERS, RCRD D-7650
- 4) LOT LINE REVISION 803 LAFAYETTE ROAD PORTSMOUTH, NEW HAMPSHIRE FOR B.P.P.M., INC. DATED: 7/13/2000, PREPARED BY JAMES VERRA AND ASSOCIATED, INC., RCRD D-28325
- 5) ALTA/ACSM LAND TITLE SURVEY (URBAN), MAP 245, LOTS 3 & 4, KNIGHT BROADCASTING, 815 LAFAYETTE ROAD, PORTSMOUTH, NEW HAMPSHIRE, SCALE: 1"=50', DATED: SEPTEMBER 19, 2000, PREPARED BY CUCCO & CORMIER ENGINEERING ASSOCIATES, INC., RCRD D-28739. **PLAN NOT HELD**
- 6) REVISED ACCESS EASEMENT PLAN & TAX ASSESSMENT/PRORATION PLAN TAX MAP 245 - LOTS 3 & 4 OVER LAND OF: iHEARTMEDIA & ENTERTAINMENT, INC. 815 LAFAYETTE ROAD CITY OF PORTSMOUTH COUNTY OF ROCKINGHAM STATE OF NEW HAMPSHIRE PREPARED BY AMBIT ENGINEERING, INC. DATED MAY 2022. R.C.R.D. D-43541

NO.	DESCRIPTION	DATE
0	ISSUED FOR COMMENT	2/2/23

SCALE: 1" = 30' JANUARY 2023

**EXISTING CONDITIONS
PLAN**

C1

I CERTIFY THAT THIS PLAN WAS PREPARED UNDER MY DIRECT SUPERVISION, WHICH HAS AN ACCURACY OF THE CLOSED TRAVERSE THAT EXCEEDS THE PRECISION OF 1:15,000.

John R. Chagnon
JOHN R. CHAGNON, LLS 738

2.17.23
DATE

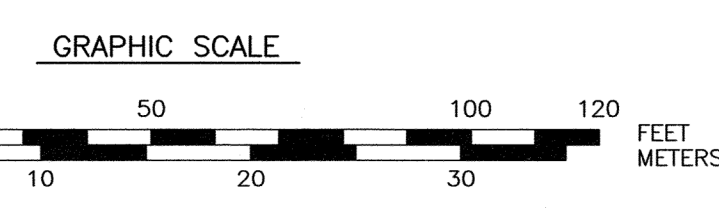
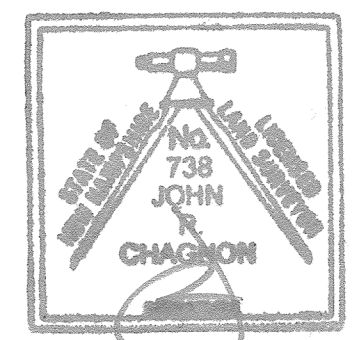

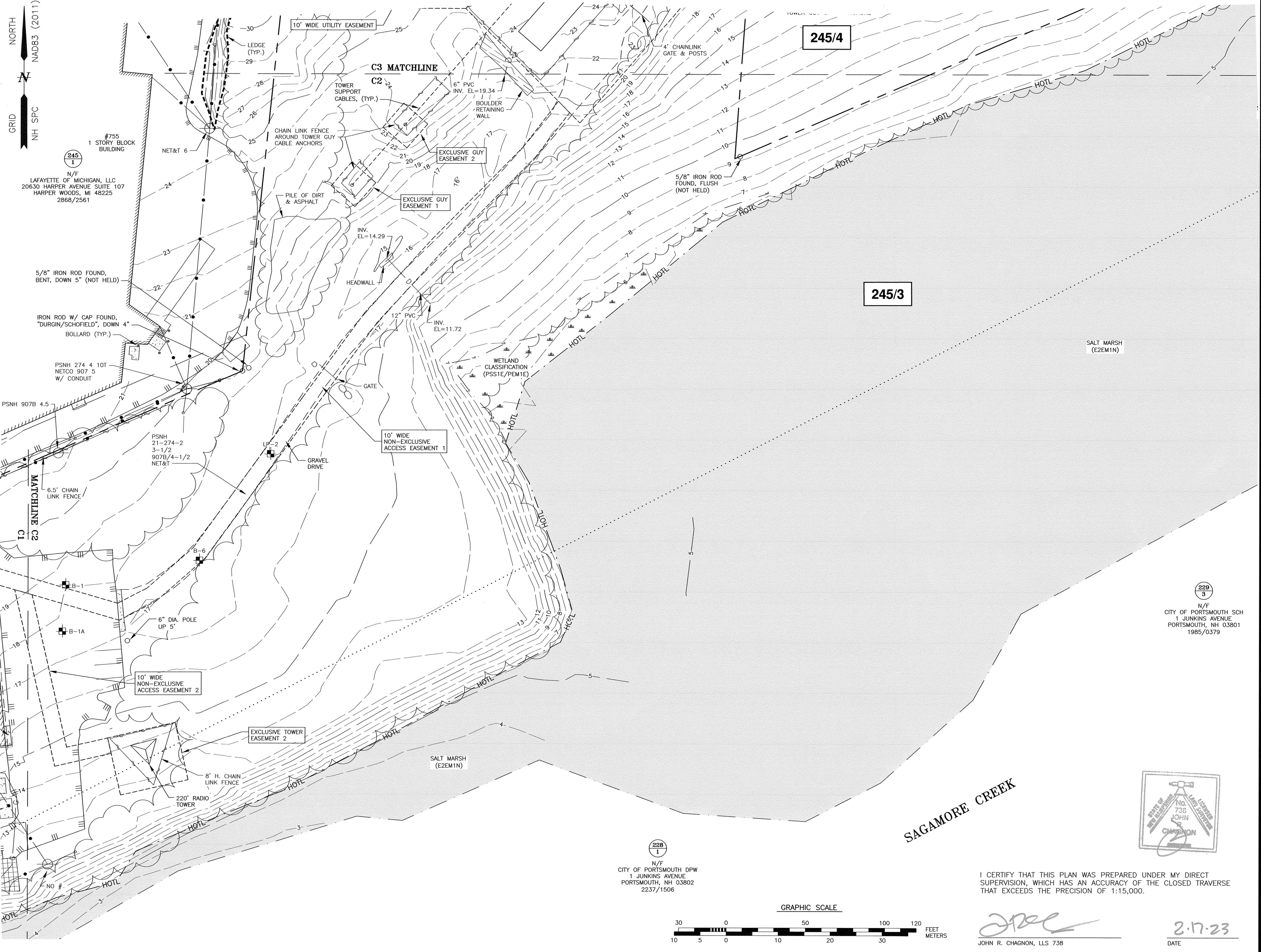

NORTH
NAD83 (2011)

GRID
NH SPC

245/1
N/F
LAFAYETTE OF MICHIGAN, LLC
20630 HARPER AVENUE SUITE 107
HARPER WOODS, MI 48225
2868/2561

5/8" IRON ROD FOUND,
BENT, DOWN 5" (NOT HELD)

IRON ROD W/ CAP FOUND,
"DURGIN/SCHOFIELD", DOWN 4"
BOLLARD (TYP.)

PSNH 274 4 10T
NETCO 907 5
W/ CONDUIT

PSNH 907B 4.5

PSNH
21-274-2
3-1/2
907B/4-1/2
NET&T

6.5' CHAIN
LINK FENCE

6" DIA. POLE
UP 5"

10' WIDE
NON-EXCLUSIVE
ACCESS EASEMENT 2

EXCLUSIVE TOWER
EASEMENT 2

8' H. CHAIN
LINK FENCE

220' RADIO
TOWER

NO #

10' WIDE UTILITY EASEMENT

LEDGE (TYP.)

TOWER SUPPORT
CABLES, (TYP.)

CHAIN LINK FENCE
AROUND TOWER GUY
CABLE ANCHORS

PILE OF DIRT
& ASPHALT

C3 MATCHLINE

C2

6" PVC
INV. EL.=19.34

EXCLUSIVE GUY
EASEMENT 2

EXCLUSIVE GUY
EASEMENT 1

INV. EL.=14.29

HEADWALL

12" PVC
INV. EL.=11.72

GATE

10' WIDE
NON-EXCLUSIVE
ACCESS EASEMENT 1

CRAGEL
DRIVE

WETLAND
CLASSIFICATION
(PSS1E/PEM1E)

SALT MARSH
(E2EM1N)

5/8" IRON ROD FOUND,
BENT, DOWN 5" (NOT HELD)

5/8" IRON ROD FOUND,
FLUSH
(NOT HELD)

4" CHAINLINK
GATE & POSTS

245/4

245/3

SALT MARSH
(E2EM1N)

SAGAMORE CREEK

228/1
N/F
CITY OF PORTSMOUTH DPW
1 JUNKINS AVENUE
PORTSMOUTH, NH 03802
2237/1506

229/3
N/F
CITY OF PORTSMOUTH SCH
1 JUNKINS AVENUE
PORTSMOUTH, NH 03801
1985/0379

- 1) THE CONTRACTOR SHALL NOTIFY DIG SAFE AT 1-888-DIG-SAFE (1-888-344-7233) AT LEAST 72 HOURS PRIOR TO COMMENCING ANY EXCAVATION ON PUBLIC OR PRIVATE PROPERTY WITHIN 100 FEET OF UNDERGROUND UTILITIES. THE EXCAVATOR IS RESPONSIBLE TO MAINTAIN MARKS. DIG SAFE TICKETS EXPIRE IN THIRTY DAYS.
- 2) UNDERGROUND UTILITY LOCATIONS ARE BASED UPON BEST AVAILABLE EVIDENCE AND ARE NOT FIELD VERIFIED. LOCATING AND PROTECTING ANY ABOVEGROUND OR UNDERGROUND UTILITIES IS THE SOLE RESPONSIBILITY OF THE CONTRACTOR AND/OR THE OWNER. UTILITY CONFLICTS SHOULD BE REPORTED AT ONCE TO THE DESIGN ENGINEER.
- 3) CONTRACTOR SHALL INSTALL AND MAINTAIN EROSION CONTROL MEASURES IN ACCORDANCE WITH THE "NEW HAMPSHIRE STORMWATER MANUAL, VOLUME 3, EROSION AND SEDIMENT CONTROLS DURING CONSTRUCTION. (NHDES DECEMBER 2008).

**SITE DEVELOPMENT
815 LAFAYETTE ROAD
PORTSMOUTH, N.H.**

NO.	DESCRIPTION	DATE
0	ISSUED FOR COMMENT	2/2/23
REVISIONS		

SCALE: 1" = 30' JANUARY 2023

EXISTING CONDITIONS
PLAN

C2

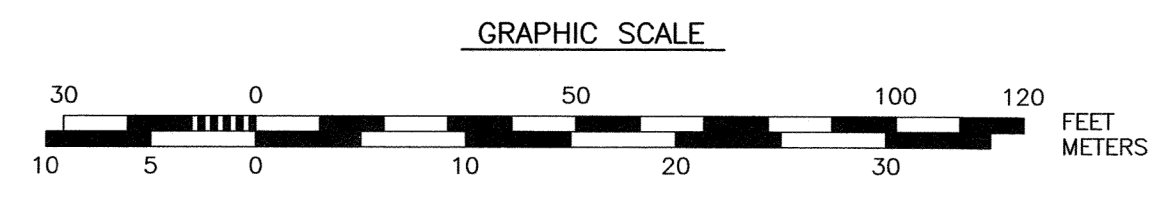

I CERTIFY THAT THIS PLAN WAS PREPARED UNDER MY DIRECT SUPERVISION, WHICH HAS AN ACCURACY OF THE CLOSED TRAVERSE THAT EXCEEDS THE PRECISION OF 1:15,000.

JRC
JOHN R. CHAGNON, LLS 738

2-17-23
DATE

1) THE CONTRACTOR SHALL NOTIFY DIG SAFE AT 1-888-DIG-SAFE (1-888-344-7233) AT LEAST 72 HOURS PRIOR TO COMMENCING ANY EXCAVATION ON PUBLIC OR PRIVATE PROPERTY WITHIN 100 FEET OF UNDERGROUND UTILITIES. THE EXCAVATOR IS RESPONSIBLE TO MAINTAIN MARKS. DIG SAFE TICKETS EXPIRE IN THIRTY DAYS.

2) UNDERGROUND UTILITY LOCATIONS ARE BASED UPON BEST AVAILABLE EVIDENCE AND ARE NOT FIELD VERIFIED. LOCATING AND PROTECTING ANY ABOVEGROUND OR UNDERGROUND UTILITIES IS THE SOLE RESPONSIBILITY OF THE CONTRACTOR AND/OR THE OWNER. UTILITY CONFLICTS SHOULD BE REPORTED AT ONCE TO THE DESIGN ENGINEER.

3) CONTRACTOR SHALL INSTALL AND MAINTAIN EROSION CONTROL MEASURES IN ACCORDANCE WITH THE "NEW HAMPSHIRE STORMWATER MANUAL, VOLUME 3, EROSION AND SEDIMENT CONTROLS DURING CONSTRUCTION. (NHDES DECEMBER 2008).

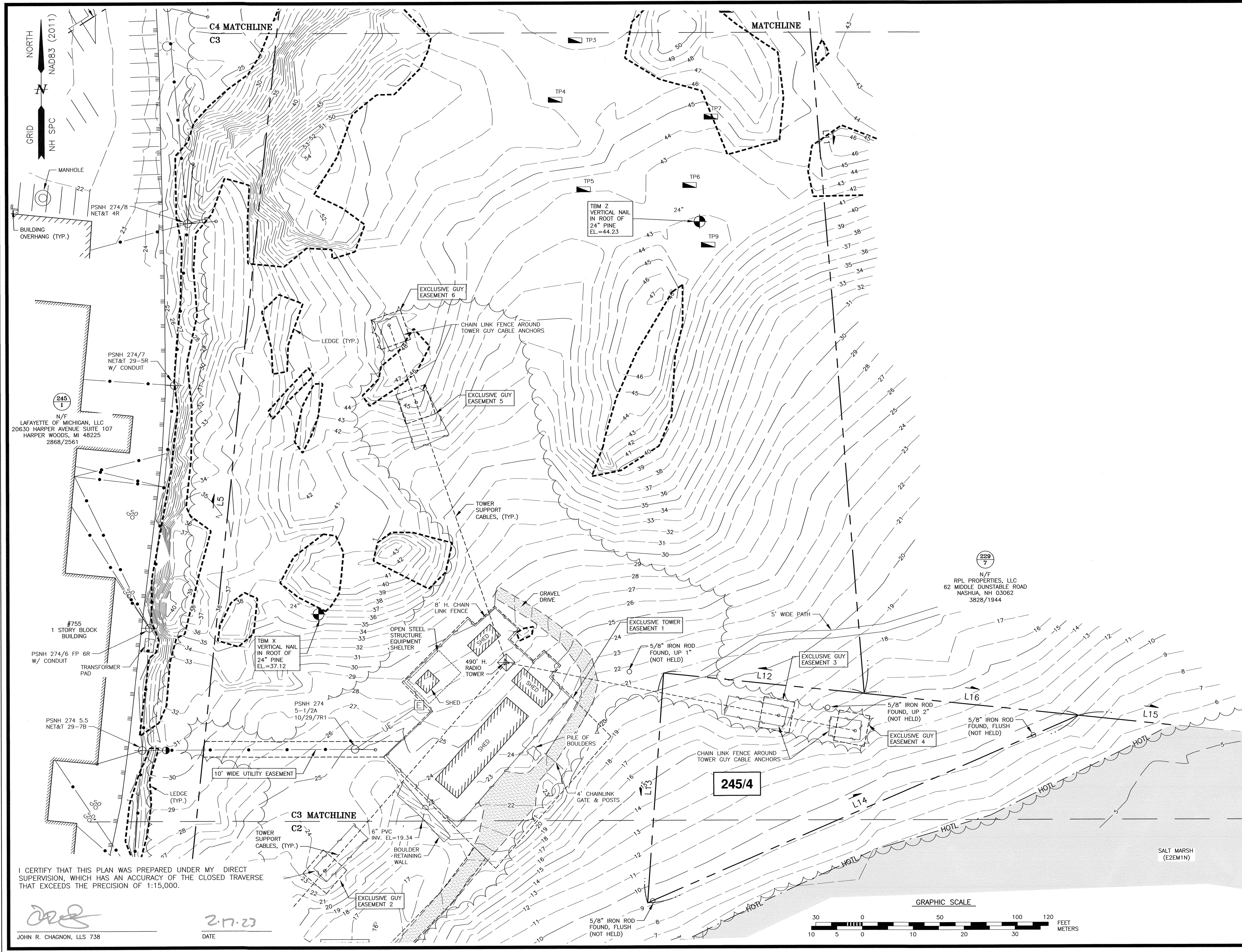

I CERTIFY THAT THIS PLAN WAS PREPARED UNDER MY DIRECT SUPERVISION, WHICH HAS AN ACCURACY OF THE CLOSED TRAVERSE THAT EXCEEDS THE PRECISION OF 1:15,000.

[Signature]
JOHN R. CHAGNON, LLS 738
DATE 2.17.23

**SITE DEVELOPMENT
815 LAFAYETTE ROAD
PORTSMOUTH, N.H.**

NO.	DESCRIPTION	DATE
0	ISSUED FOR COMMENT	2/2/23
REVISIONS		

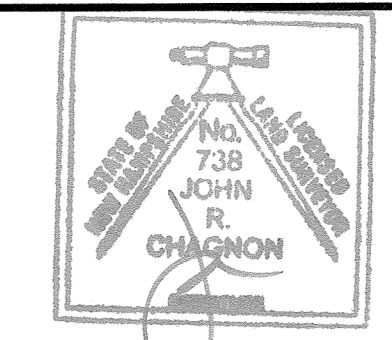

SCALE: 1" = 30' JANUARY 2023

**EXISTING CONDITIONS
PLAN**

C3

NORTH
NAD83 (2011)
GRID
NH SPC

- 1) THE CONTRACTOR SHALL NOTIFY DIG SAFE AT 1-888-DIG-SAFE (1-888-344-7233) AT LEAST 72 HOURS PRIOR TO COMMENCING ANY EXCAVATION ON PUBLIC OR PRIVATE PROPERTY WITHIN 100 FEET OF UNDERGROUND UTILITIES. THE EXCAVATOR IS RESPONSIBLE TO MAINTAIN MARKS. DIG SAFE TICKETS EXPIRE IN THIRTY DAYS.
- 2) UNDERGROUND UTILITY LOCATIONS ARE BASED UPON BEST AVAILABLE EVIDENCE AND ARE NOT FIELD VERIFIED. LOCATING AND PROTECTING ANY ABOVEGROUND OR UNDERGROUND UTILITIES IS THE SOLE RESPONSIBILITY OF THE CONTRACTOR AND/OR THE OWNER. UTILITY CONFLICTS SHOULD BE REPORTED AT ONCE TO THE DESIGN ENGINEER.
- 3) CONTRACTOR SHALL INSTALL AND MAINTAIN EROSION CONTROL MEASURES IN ACCORDANCE WITH THE "NEW HAMPSHIRE STORMWATER MANUAL, VOLUME 3, EROSION AND SEDIMENT CONTROLS DURING CONSTRUCTION. (NHDES DECEMBER 2008).

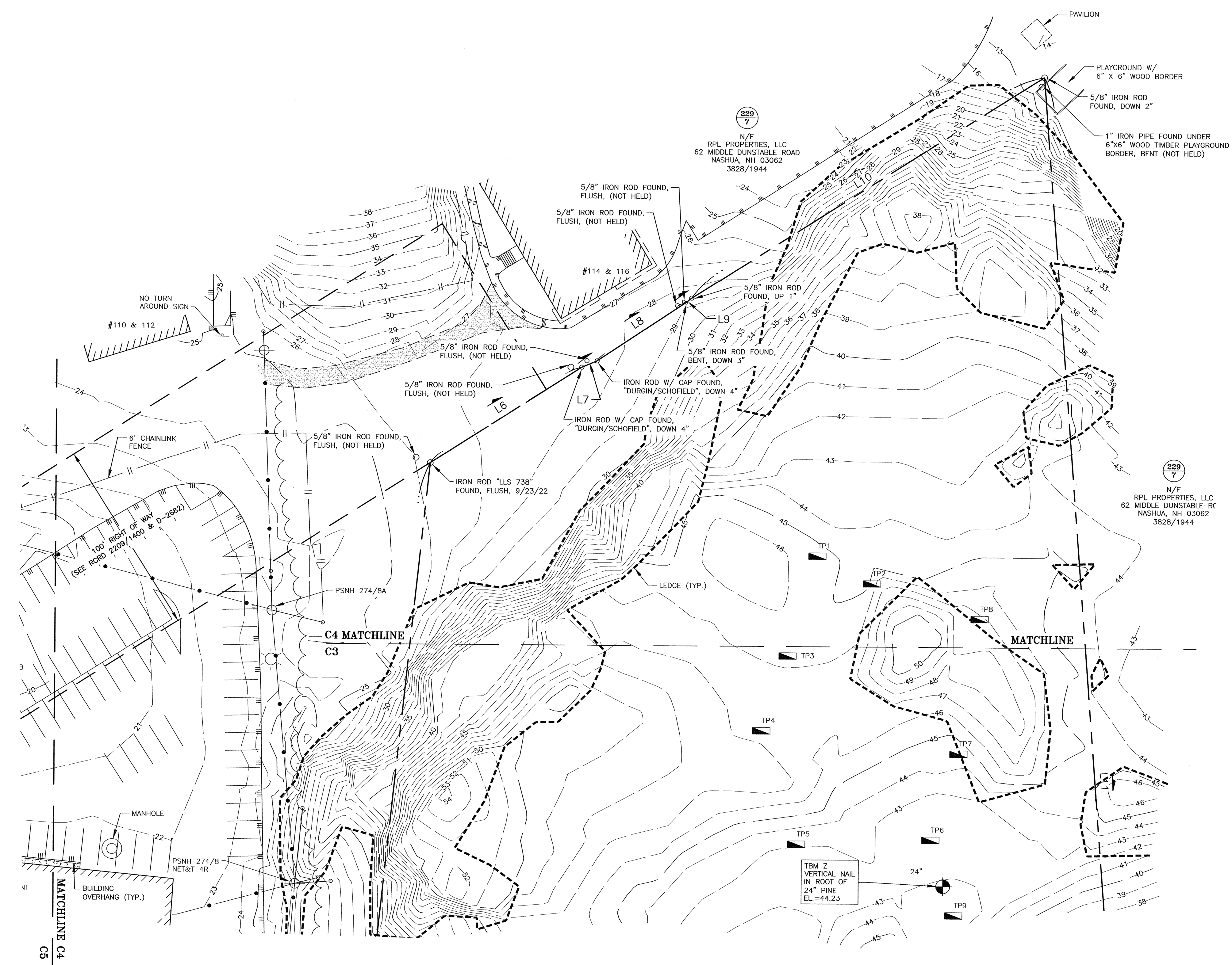

I CERTIFY THAT THIS PLAN WAS PREPARED UNDER MY DIRECT SUPERVISION, WHICH HAS AN ACCURACY OF THE CLOSED TRAVERSE THAT EXCEEDS THE PRECISION OF 1:15,000.

[Signature]
JOHN R. CHAGNON, LLS 738

2.17.23
DATE

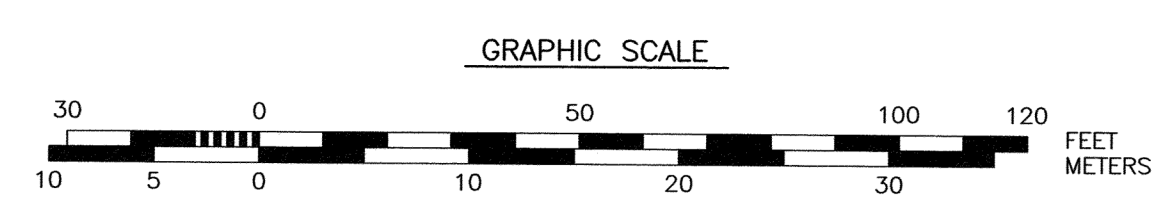
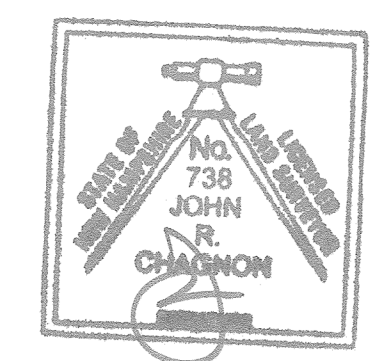

**SITE DEVELOPMENT
815 LAFAYETTE ROAD
PORTSMOUTH, N.H.**

NO.	DESCRIPTION	DATE
0	ISSUED FOR COMMENT	2/2/23

REVISIONS	

SCALE: 1" = 30' JANUARY 2023

**EXISTING CONDITIONS
PLAN**

C4

NORTH
NAD83 (2011)
GRID
NH SPC

- 1) THE CONTRACTOR SHALL NOTIFY DIG SAFE AT 1-888-DIG-SAFE (1-888-344-7233) AT LEAST 72 HOURS PRIOR TO COMMENCING ANY EXCAVATION ON PUBLIC OR PRIVATE PROPERTY WITHIN 100 FEET OF UNDERGROUND UTILITIES. THE EXCAVATOR IS RESPONSIBLE TO MAINTAIN MARKS. DIG SAFE TICKETS EXPIRE IN THIRTY DAYS.
- 2) UNDERGROUND UTILITY LOCATIONS ARE BASED UPON BEST AVAILABLE EVIDENCE AND ARE NOT FIELD VERIFIED. LOCATING AND PROTECTING ANY ABOVEGROUND OR UNDERGROUND UTILITIES IS THE SOLE RESPONSIBILITY OF THE CONTRACTOR AND/OR THE OWNER. UTILITY CONFLICTS SHOULD BE REPORTED AT ONCE TO THE DESIGN ENGINEER.
- 3) CONTRACTOR SHALL INSTALL AND MAINTAIN EROSION CONTROL MEASURES IN ACCORDANCE WITH THE "NEW HAMPSHIRE STORMWATER MANUAL, VOLUME 3, EROSION AND SEDIMENT CONTROLS DURING CONSTRUCTION. (NHDES DECEMBER 2008).

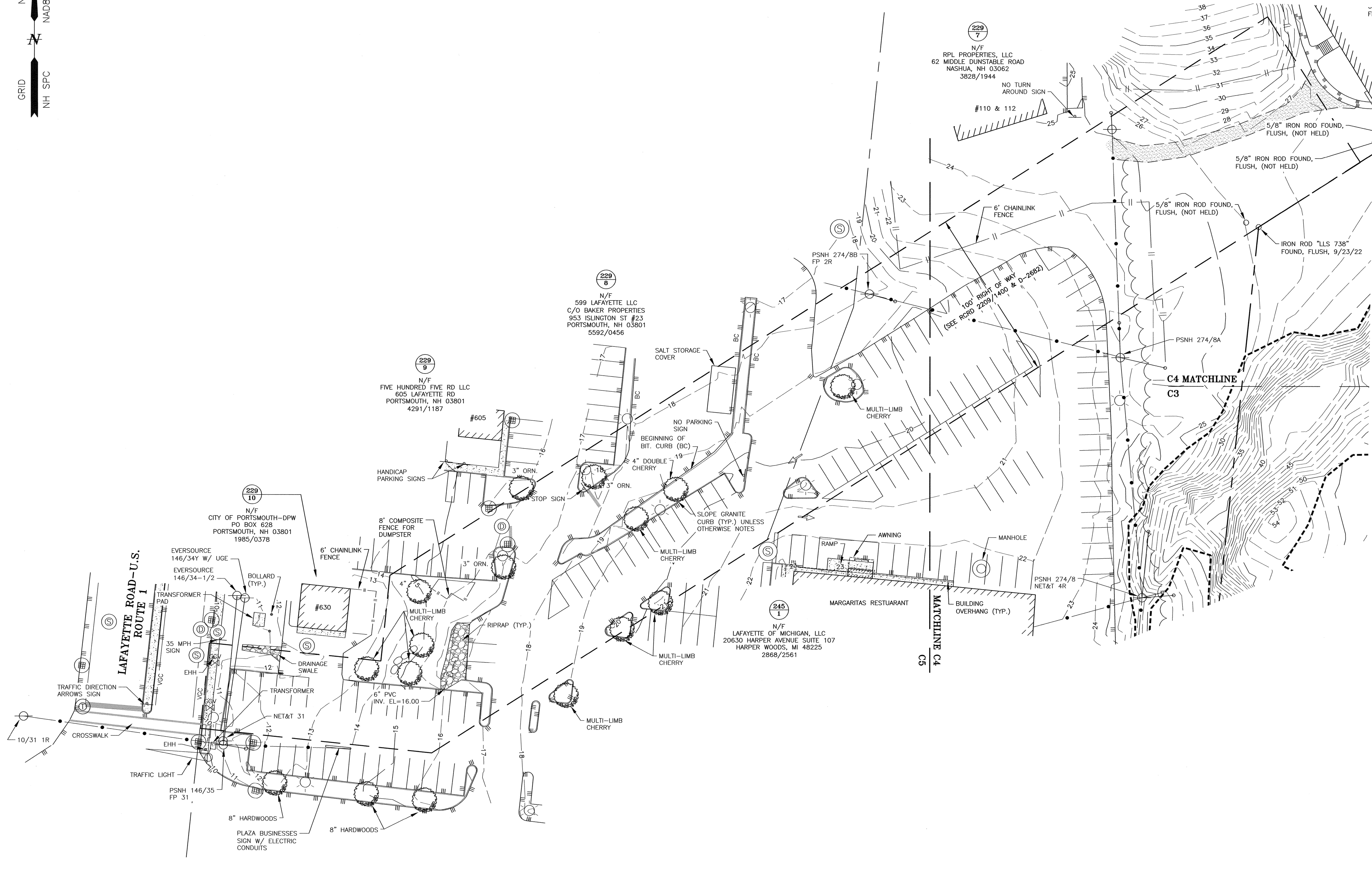

**SITE DEVELOPMENT
815 LAFAYETTE ROAD
PORTSMOUTH, N.H.**

NO.	DESCRIPTION	DATE
0	ISSUED FOR COMMENT	2/2/23
REVISIONS		

SCALE: 1" = 30' JANUARY 2023

EXISTING CONDITIONS PLAN **C5**

I CERTIFY THAT THIS PLAN WAS PREPARED UNDER MY DIRECT SUPERVISION, WHICH HAS AN ACCURACY OF THE CLOSED TRAVERSE THAT EXCEEDS THE PRECISION OF 1:15,000.

[Signature]
JOHN R. CHAGNON, LLS 738

2.17.23
DATE

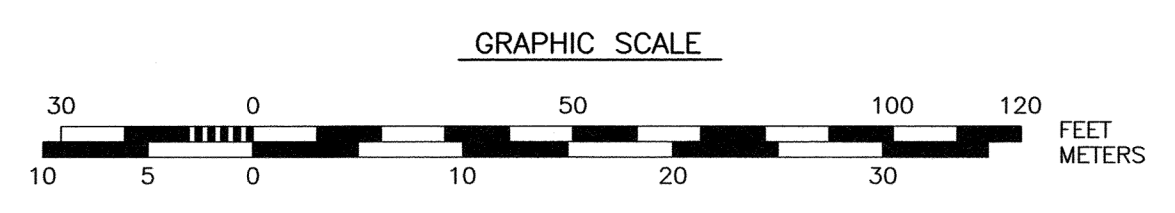
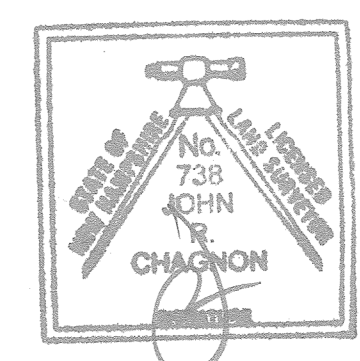

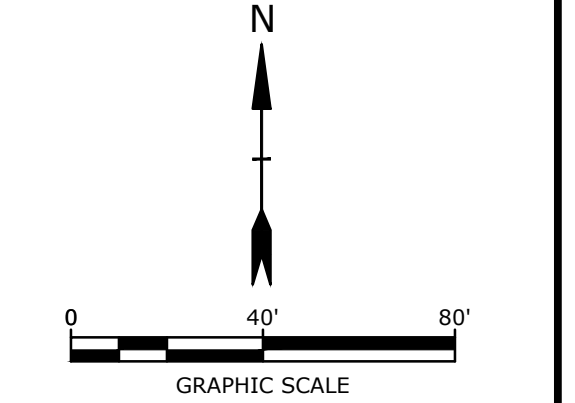

PROGRESS PRINT

SEE SHEET G-100 FOR SITE PLAN NOTES AND LEGEND

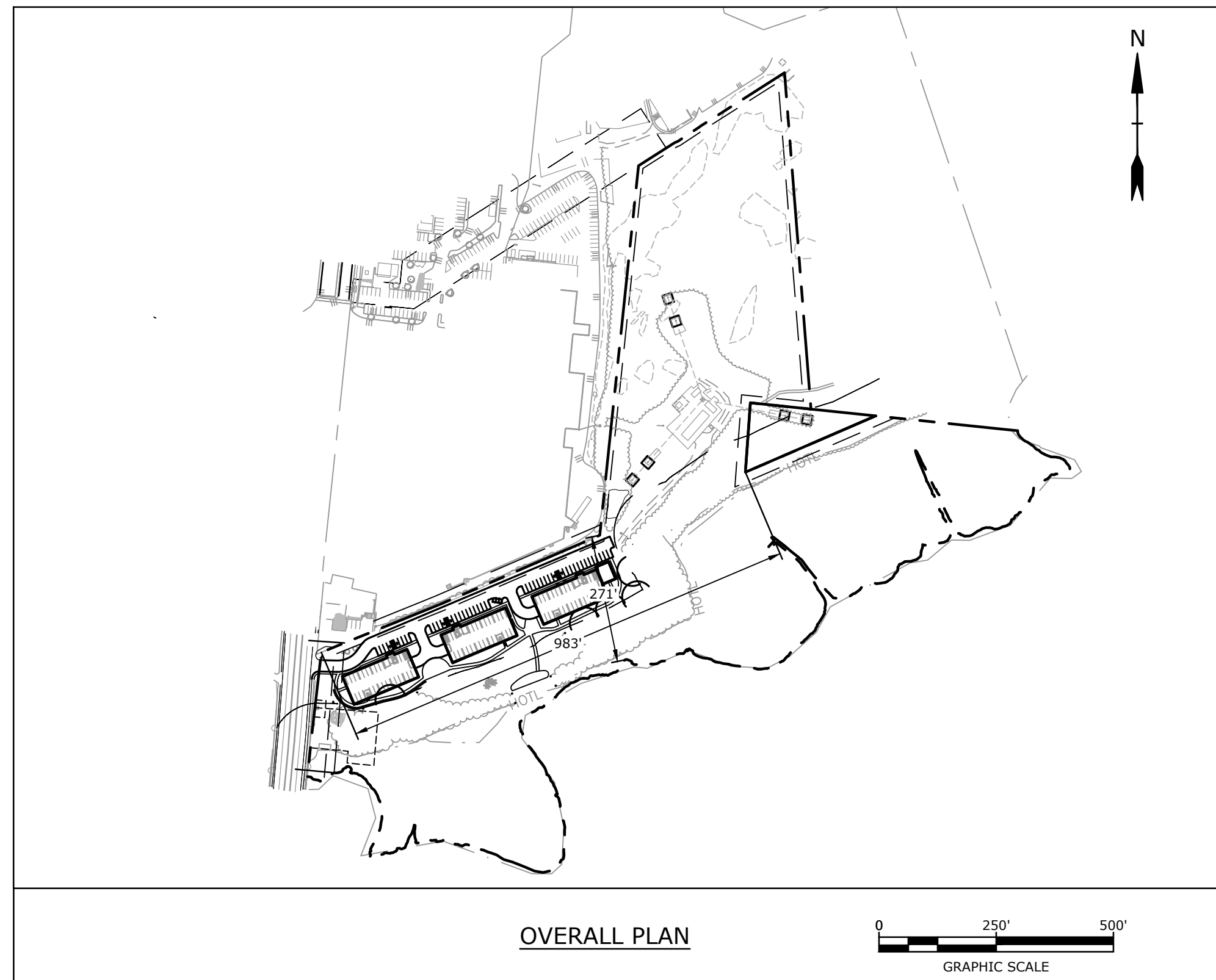

OVERALL PLAN

SITE DATA:
 LOCATION: TAX MAP 245, LOT 3
 815 LAFAYETTE ROAD
 PORTSMOUTH, NEW HAMPSHIRE

ZONING DISTRICT: GATEWAY DISTRICT (G1)

PROPOSED USE: MULTIFAMILY

DIMENSIONAL REQUIREMENTS:	REQUIRED	PROPOSED
MINIMUM LOT AREA:	10,000 SF	±855,567 SF

MINIMUM SITE WIDTH:	75 FT	±271 FT
---------------------	-------	---------

MINIMUM SITE LENGTH:	100 FT	±971 FT
----------------------	--------	---------

MINIMUM COMMUNITY SPACE:	10%	
--------------------------	-----	--

MINIMUM STREET FRONTAGE:		
APARTMENT BUILDING:	100 FT	±288 FT

FRONT YARD SETBACK:		
LAFAYETTE ROAD SETBACK	70-90 FT	90 FT

MIN. SIDE YARD SETBACK:		
APARTMENT BUILDING:	15 FT	±56 FT

MIN. REAR YARD SETBACK:		
APARTMENT BUILDING:	20 FT	±349 FT

MAXIMUM BUILDING HEIGHT:	50 FT	<50 FT
APARTMENT BUILDING:		

MAXIMUM BUILDING COVERAGE:	50%	±3.6%
----------------------------	-----	-------

FRONT LOT LINE BUILD OUT:	50%	±0% ⁽¹⁾
---------------------------	-----	--------------------

MINIMUM OPEN SPACE:	20%	±91%
---------------------	-----	------

PARKING REQUIREMENTS:	REQUIRED	PROPOSED
PARKING STALL LAYOUT:		
• STANDARD 90°	WIDTH: 8.5' MIN LENGTH: 19' MIN	8.5' MIN 19' MIN

DRIVE AISLE WIDTH:		
• 90° (2-WAY TRAFFIC)	24 FT	24 FT (MIN)

PARKING SPACE REQUIREMENTS:

MINIMUM APARTMENT PARKING
 1.3 SPACES PER UNIT x 72 UNITS = 94 SPACES
 +1 VISITOR PER 5 UNITS = 15 SPACES

TOTAL APARTMENT PARKING REQUIRED = 109 SPACES

ADA PARKING REQUIREMENTS:
 1 / 25 STANDARD PARKING STALLS

ADA SPACES REQUIRED = 5 SPACES
 ADA SPACES PROVIDED = 6 SPACES

PARKING REQUIRED	109 SPACES
PARKING PROVIDED	118 SPACES

NOTES:

(1) - ZONING VARIANCE REQUESTED FROM SECTION 10.5B33.20, 50% FRONT LOT LINE BUILD OUT, AND SECTION 10.5b33.30, PRIMARY FACADE BUILT PARALLEL TO A FRONT LOT LINE.

PROPOSED DEVELOPMENT

PROSPECT NORTH 815, LLC

815 LAFAYETTE ROAD
 PORTSMOUTH, NEW HAMPSHIRE

MARK	DATE	DESCRIPTION

PROJECT NO:	M5131-001
DATE:	9/5/2023
FILE:	M5131-001-DSGN.dwg
DRAWN BY:	NHW/CJK
DESIGNED/CHECKED BY:	NAH
APPROVED BY:	PMC

SITE PLAN

SCALE: AS SHOWN

Last Saved: 9/5/2023 11:14am By: Chrissie
 Plotted On: Sep 05 2023 11:14am By: Chrissie
 Tighe & Bond\3\105131\105131_102_Development, LLC\001_815 Lafayette Road\Drawings\AutoCAD\M5131_001_DSGN.dwg

SEE SHEET G-100 FOR UTILITY PLAN NOTES AND LEGEND

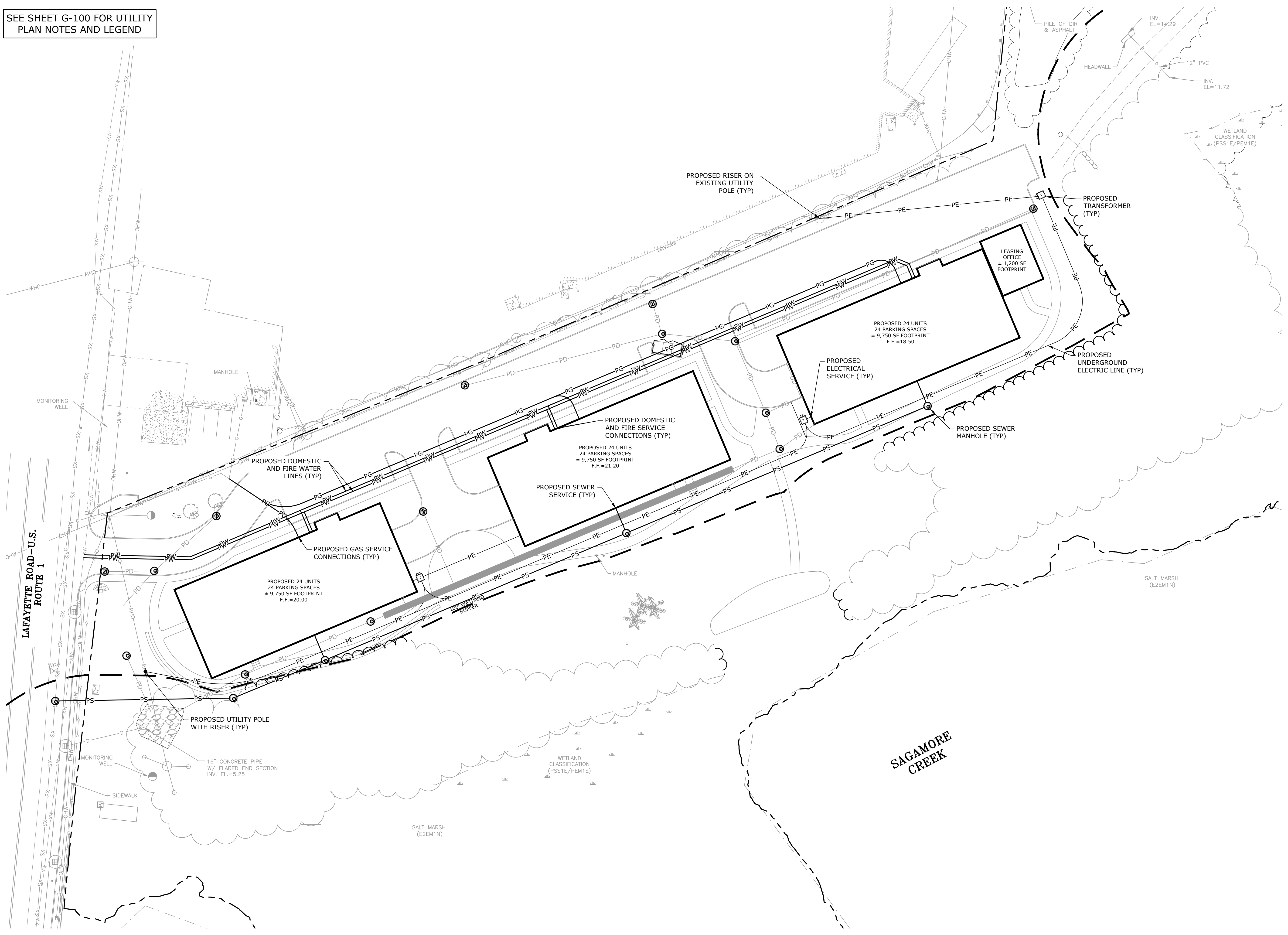

Tighe & Bond

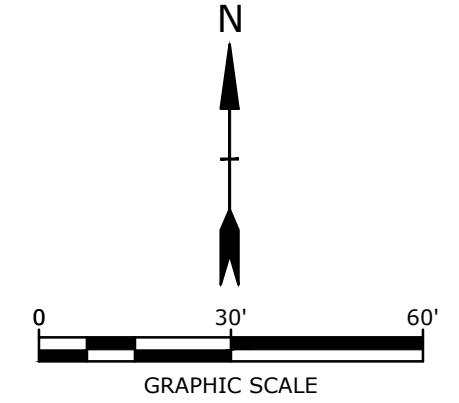

PROGRESS PRINT

PROPOSED DEVELOPMENT

PROSPECT NORTH 815, LLC

815 LAFAYETTE ROAD
PORTSMOUTH,
NEW HAMPSHIRE

MARK	DATE	DESCRIPTION

PROJECT NO:	M5131-001
DATE:	9/5/2023
FILE:	M5131-001-DSGN.dwg
DRAWN BY:	NHW/CLK
DESIGNED/CHECKED BY:	NAH
APPROVED BY:	PMC

UTILITY PLAN

SCALE: AS SHOWN

C-104

Last Saved: 9/5/2023 11:15am By: Chriscull
 Plotted On: Sep 05, 2023 11:15am
 Tighe & Bond\3\1\19531 1\2 Development, LLC\001 815 Lafayette Road\Drawings\AutoCAD\M5131_001-DSGN.dwg

GENERAL PROJECT INFORMATION

PROJECT APPLICANT: PROSPECT NORTH 815, LLC
 PROJECT NAME: PROPOSED DEVELOPMENT
 PROJECT ADDRESS: 815 LAFAYETTE ROAD, PORTSMOUTH NH
 PROJECT MAP / LOT: TAX MAP 314, LOT 2
 PROJECT LATITUDE: 43°-03'-06.32"N
 PROJECT LONGITUDE: 70°-46'-07.81"W

PROJECT DESCRIPTION

THE PROPOSED PROJECT CONSISTS OF REDEVELOPING THE EXISTING WHEB SITE TO A MULTI-FAMILY HOUSING SITE. THE SITE WILL CONSIST OF THREE PRIMARY BUILDING, ALL HAVING A SQUARE FOOTAGE 9,750 SF WITH 24 DWELLING UNITS IN EACH.

DISTURBED AREA

THE TOTAL AREA TO BE DISTURBED IS APPROXIMATELY 2.90 ACRES.

SOIL CHARACTERISTICS

BASED ON THE NRCS WEB SOIL SURVEY FOR STRAFFORD COUNTY - NEW HAMPSHIRE, THE SOILS ON SITE CONSIST OF URBAN LAND-CANTON GRAVELLY FINE SANDY LOAM SOILS WHICH HAVE A FAST INFILTRATION RATE WHEN THOROUGHLY WET. THESE SOILS HAVE A HYDROLOGIC SOIL GROUP RATING OF D.

NAME OF RECEIVING WATERS

THE STORM WATER RUNOFF WILL ULTIMATELY DISCHARGE INTO THE SAGAMORE CREEK TO THE SOUTH OF THE SITE.

CONSTRUCTION SEQUENCE OF MAJOR ACTIVITIES:

- CUT AND CLEAR TREES.
- CONSTRUCT TEMPORARY AND PERMANENT SEDIMENT, EROSION AND DETENTION CONTROL FACILITIES. EROSION, SEDIMENT AND DETENTION MEASURES SHALL BE INSTALLED PRIOR TO ANY EARTH MOVING OPERATIONS THAT WILL INFLUENCE STORMWATER RUNOFF SUCH AS:
 - NEW CONSTRUCTION
 - CONTROL OF DUST
 - NEARNESS OF CONSTRUCTION SITE TO RECEIVING WATERS
 - CONSTRUCTION DURING LATE WINTER AND EARLY SPRING
- ALL PERMANENT DITCHES, SWALES, DETENTION, RETENTION AND SEDIMENTATION BASINS TO BE STABILIZED USING THE VEGETATIVE AND NON-STRUCTURAL BMPS PRIOR TO DIRECTING RUNOFF TO THEM.
- CLEAR AND DISPOSE OF DEBRIS.
- CONSTRUCT TEMPORARY CULVERTS AND DIVERSION CHANNELS AS REQUIRED.
- GRADE AND GRAVEL ROADWAYS AND PARKING AREAS - ALL ROADS AND PARKING AREA SHALL BE STABILIZED WITHIN 72 HOURS OF ACHIEVING FINISHED GRADE.
- BEGIN PERMANENT AND TEMPORARY SEEDING AND MULCHING. ALL CUT AND FILL SLOPES SHALL BE SEEDED AND MULCHED WITHIN 72 HOURS OF ACHIEVING FINISHED GRADE.
- DAILY, OR AS REQUIRED, CONSTRUCT TEMPORARY BERMS, DRAINS, DITCHES, PERIMETER EROSION CONTROL MEASURES, SEDIMENT TRAPS, ETC., MULCH AND SEED AS REQUIRED.
- SEDIMENT TRAPS AND/OR BASINS SHALL BE USED AS NECESSARY TO CONTAIN RUNOFF UNTIL SOILS ARE STABILIZED.
- FINISH PAVING ALL ROADWAYS AND PARKING LOTS.
- INSPECT AND MAINTAIN ALL EROSION AND SEDIMENT CONTROL MEASURES.
- COMPLETE PERMANENT SEEDING AND LANDSCAPING.
- REMOVE TRAPPED SEDIMENTS FROM COLLECTOR DEVICES AS APPROPRIATE AND THEN REMOVE TEMPORARY EROSION CONTROL MEASURES.

SPECIAL CONSTRUCTION NOTES:

- THE CONSTRUCTION SEQUENCE MUST LIMIT THE DURATION AND AREA OF DISTURBANCE.
- THE PROJECT IS TO BE MANAGED IN A MANNER THAT MEETS THE REQUIREMENTS AND INTENT OF RSA 430:53 AND CHAPTER AGR 3800 RELATIVE TO INVASIVE SPECIES.

EROSION CONTROL NOTES:

- ALL EROSION CONTROL MEASURES AND PRACTICES SHALL CONFORM TO THE "NEW HAMPSHIRE STORMWATER MANUAL VOLUME 3: EROSION AND SEDIMENT CONTROLS DURING CONSTRUCTION" PREPARED BY THE NHDES.
- PRIOR TO ANY WORK OR SOIL DISTURBANCE, CONTRACTOR SHALL SUBMIT SHOP DRAWINGS FOR EROSION CONTROL MEASURES AS REQUIRED IN THE PROJECT MANUAL. CONTRACTOR SHALL INSTALL TEMPORARY EROSION CONTROL BARRIERS, INCLUDING HAY BALES, SILT FENCES, MULCH BERMS, SILT SACKS AND SILT SOCKS AS SHOWN IN THESE DRAWINGS AS THE FIRST ORDER OF WORK.
- SILT SACK INLET PROTECTION SHALL BE INSTALLED IN ALL EXISTING AND PROPOSED CATCH BASIN INLETS WITHIN THE WORK LIMITS AND BE MAINTAINED FOR THE DURATION OF THE PROJECT.
- PERIMETER CONTROLS INCLUDING SILT FENCES, MULCH BERM, SILT SOCK, AND/OR HAY BALE BARRIERS SHALL BE MAINTAINED FOR THE DURATION OF THE PROJECT UNTIL NON-PAVED AREAS HAVE BEEN STABILIZED.
- THE CONTRACTOR SHALL REMOVE AND PROPERLY DISPOSE OF ALL TEMPORARY EROSION CONTROL DEVICES UPON COMPLETION OF CONSTRUCTION.
- ALL DISTURBED AREAS NOT OTHERWISE BEING TREATED SHALL RECEIVE 6" LOAM, SEED AND FERTILIZER.
- INSPECT ALL INLET PROTECTION AND PERIMETER CONTROLS WEEKLY AND AFTER EACH RAIN STORM OF 0.25 INCH OR GREATER. REPAIR/MODIFY PROTECTION AS NECESSARY TO MAXIMIZE EFFICIENCY OF FILTER. REPLACE ALL FILTERS WHEN SEDIMENT IS 1/3 THE FILTER HEIGHT.
- CONSTRUCT EROSION CONTROL BLANKETS ON ALL SLOPES STEEPER THAN 3:1.

STABILIZATION:

- AN AREA SHALL BE CONSIDERED STABLE WHEN ONE OF THE FOLLOWING HAS OCCURRED:
 - BASE COURSE GRAVELS HAVE BEEN INSTALLED IN AREAS TO BE PAVED;
 - A MINIMUM OF 85% VEGETATED GROWTH HAS BEEN ESTABLISHED;
 - A MINIMUM OF 3" OF NON-EROSIVE MATERIAL SUCH AS STONE OR RIPRAP HAS BEEN INSTALLED;
 - EROSION CONTROL BLANKETS HAVE BEEN PROPERLY INSTALLED.;
 - IN AREAS TO BE PAVED, "STABLE" MEANS THAT BASE COURSE GRAVELS MEETING THE REQUIREMENTS OF NHDOT STANDARD FOR ROAD AND BRIDGE CONSTRUCTION, 2016, ITEM 304.2 HAVE BEEN INSTALLED.
- WINTER STABILIZATION PRACTICES:
 - ALL PROPOSED VEGETATED AREAS THAT DO NOT EXHIBIT A MINIMUM OF 85 PERCENT VEGETATIVE GROWTH BY OCTOBER 15, OR WHICH ARE DISTURBED AFTER OCTOBER 15, SHALL BE STABILIZED BY SEEDING AND INSTALLING EROSION CONTROL BLANKETS ON SLOPES GREATER THAN 3:1, AND SEEDING AND PLACING 3 TO 4 TONS OF MULCH PER ACRE, SECURED WITH ANCHORED NETTING, ELSEWHERE. THE INSTALLATION OF EROSION CONTROL BLANKETS OR MULCH AND NETTING SHALL NOT OCCUR OVER ACCUMULATED SNOW OR ON FROZEN GROUND AND SHALL BE COMPLETED IN ADVANCE OF THAW OR SPRING MELT EVENTS;
 - ALL DITCHES OR SWALES WHICH DO NOT EXHIBIT A MINIMUM OF 85 PERCENT VEGETATIVE GROWTH BY OCTOBER 15, OR WHICH ARE DISTURBED AFTER OCTOBER 15, SHALL BE STABILIZED TEMPORARILY WITH STONE OR EROSION CONTROL BLANKETS APPROPRIATE FOR THE DESIGN FLOW CONDITIONS;
 - AFTER OCTOBER 15, INCOMPLETE ROAD OR PARKING SURFACES, WHERE WORK HAS STOPPED FOR THE WINTER SEASON, SHALL BE PROTECTED WITH A MINIMUM OF 3 INCHES OF CRUSHED GRAVEL PER NHDOT ITEM 304.3, OR IF CONSTRUCTION IS TO CONTINUE THROUGH THE WINTER SEASON BE CLEARED OF ANY ACCUMULATED SNOW AFTER EACH STORM EVENT;
- STABILIZATION SHALL BE INITIATED ON ALL LOAM STOCKPILES, AND DISTURBED AREAS, WHERE CONSTRUCTION ACTIVITY SHALL NOT OCCUR FOR MORE THAN TWENTY-ONE (21) CALENDAR DAYS BY THE FOURTEENTH (14TH) DAY AFTER CONSTRUCTION ACTIVITY HAS PERMANENTLY OR TEMPORARILY CEASED IN THAT AREA. STABILIZATION MEASURES TO BE USED INCLUDE:
 - TEMPORARY SEEDING;
 - MULCHING.
- ALL AREAS SHALL BE STABILIZED WITHIN 45 DAYS OF INITIAL DISTURBANCE.

- WHEN CONSTRUCTION ACTIVITY PERMANENTLY OR TEMPORARILY CEASES WITHIN 100 FEET OF NEARBY SURFACE WATERS OR DELINEATED WETLANDS, THE AREA SHALL BE STABILIZED WITHIN SEVEN (7) DAYS OR PRIOR TO A RAIN EVENT. ONCE CONSTRUCTION ACTIVITY CEASES PERMANENTLY IN AN THESE AREAS, SILT FENCES, MULCH BERMS, HAY BALE BARRIERS AND ANY EARTH/DIKES SHALL BE REMOVED ONCE PERMANENT MEASURES ARE ESTABLISHED.
- DURING CONSTRUCTION, RUNOFF WILL BE DIVERTED AROUND THE SITE WITH EARTH DIKES, PIPING OR STABILIZED CHANNELS WHERE POSSIBLE. SHEET RUNOFF FROM THE SITE WILL BE FILTERED THROUGH SILT FENCES, MULCH BERMS, HAY BALE BARRIERS, OR SILT SOCKS. ALL STORM DRAIN BASIN INLETS SHALL BE PROVIDED WITH FLARED END SECTIONS AND TRASH RACKS. THE SITE SHALL BE STABILIZED FOR THE WINTER BY NOVEMBER 15.

DUST CONTROL:

- THE CONTRACTOR SHALL BE RESPONSIBLE TO CONTROL DUST THROUGHOUT THE CONSTRUCTION PERIOD.
- DUST CONTROL METHODS SHALL INCLUDE, BUT BE NOT LIMITED TO SPRINKLING WATER ON EXPOSED AREAS, COVERING LOADED DUMP TRUCKS LEAVING THE SITE, AND TEMPORARY MULCHING.
- DUST CONTROL MEASURES SHALL BE UTILIZED SO AS TO PREVENT THE MIGRATION OF DUST FROM THE SITE TO ADJUTING AREAS.

STOCKPILES:

- LOCATE STOCKPILES A MINIMUM OF 50 FEET AWAY FROM CATCH BASINS, SWALES, AND CULVERTS.
- ALL STOCKPILES SHOULD BE SURROUNDED WITH TEMPORARY EROSION CONTROL MEASURES PRIOR TO THE ONSET OF PRECIPITATION.
- PERIMETER BARRIERS SHOULD BE MAINTAINED AT ALL TIMES, AND ADJUSTED AS NEEDED TO ACCOMMODATE THE DELIVERY AND REMOVAL OF MATERIALS FROM THE STOCKPILE. THE INTEGRITY OF THE BARRIER SHOULD BE INSPECTED AT THE END OF EACH WORKING DAY.
- PROTECT ALL STOCKPILES FROM STORMWATER RUN-OFF USING TEMPORARY EROSION CONTROL MEASURES SUCH AS BERMS, SILT SOCK, OR OTHER APPROVED PRACTICE TO PREVENT MIGRATION OF MATERIAL BEYOND THE IMMEDIATE CONFINES OF THE STOCKPILES.

OFF SITE VEHICLE TRACKING:

- THE CONTRACTOR SHALL CONSTRUCT STABILIZED CONSTRUCTION ENTRANCE(S) PRIOR TO ANY EXCAVATION ACTIVITIES.

VEGETATION:

- TEMPORARY GRASS COVER:
 - SEEDBED PREPARATION:
 - APPLY FERTILIZER AT THE RATE OF 600 POUNDS PER ACRE OF 10-10-10. APPLY LIMESTONE (EQUIVALENT TO 50 PERCENT CALCIUM PLUS MAGNESIUM OXIDE) AT A RATE OF THREE (3) TONS PER ACRE;
 - SEEDING:
 - UTILIZE ANNUAL RYE GRASS AT A RATE OF 40 LBS/ACRE;
 - WHERE THE SOIL HAS BEEN COMPACTED BY CONSTRUCTION OPERATIONS, LOOSEN SOIL TO A DEPTH OF TWO (2) INCHES BEFORE APPLYING FERTILIZER, LIME AND SEED;
 - APPLY SEED UNIFORMLY BY HAND, CYCLONE SEEDER, OR HYDROSEEDER (SLURRY INCLUDING SEED AND FERTILIZER). HYDROSEEDINGS, WHICH INCLUDE MULCH, MAY BE LEFT ON SOIL SURFACE. SEEDING RATES MUST BE INCREASED 10% WHEN HYDROSEEDING;
 - MAINTENANCE:
 - TEMPORARY SEEDING SHALL BE PERIODICALLY INSPECTED. AT A MINIMUM, 95% OF THE SOIL SURFACE SHOULD BE COVERED BY VEGETATION. IF ANY EVIDENCE OF EROSION OR SEDIMENTATION IS APPARENT, REPAIRS SHALL BE MADE AND OTHER TEMPORARY MEASURES USED IN THE INTERIM (MULCH, FILTER BARRIERS, CHECK DAMS, ETC.)
- VEGETATIVE PRACTICE:
 - FOR PERMANENT MEASURES AND PLANTINGS:
 - LIMESTONE SHALL BE THOROUGHLY INCORPORATED INTO THE LOAM LAYER AT A RATE OF THREE (3) TONS PER ACRE IN ORDER TO PROVIDE A PH VALUE OF 5.5 TO 7.6;
 - FERTILIZER SHALL BE SPREAD ON THE TOP LAYER OF LOAM AND WORKED INTO THE SURFACE. FERTILIZER APPLICATION RATE SHALL BE 800 POUNDS PER ACRE OF 10-20-20 FERTILIZER;
 - SOIL CONDITIONERS AND FERTILIZER SHALL BE APPLIED AT THE RECOMMENDED RATES AND SHALL BE THOROUGHLY WORKED INTO THE LOAM. LOAM SHALL BE RAKED UNTIL THE SURFACE IS FINELY PULVERIZED, SMOOTH AND EVEN, AND THEN COMPACTED TO AN EVEN SURFACE CONFORMING TO THE REQUIRED LINES AND GRADES WITH APPROVED ROLLERS WEIGHING BETWEEN 4-1/2 POUNDS AND 5-1/2 POUNDS PER INCH OF WIDTH;
 - SEED SHALL BE SOWN AT THE RATE SHOWN BELOW. SOWING SHALL BE DONE ON A CALM, DRY DAY, PREFERABLY BY MACHINE, BUT IF BY HAND, ONLY BY EXPERIENCED WORKMEN. IMMEDIATELY BEFORE SEEDING, THE SOIL SHALL BE LIGHTLY RAKED. ONE HALF THE SEED SHALL BE SOWN IN ONE DIRECTION AND THE OTHER HALF AT RIGHT ANGLES TO THE ORIGINAL DIRECTION. IT SHALL BE LIGHTLY RAKED INTO THE SOIL TO A DEPTH NOT OVER 1/4 INCH AND ROLLED WITH A HAND ROLLER WEIGHING NOT OVER 100 POUNDS PER LINEAR FOOT OF WIDTH;
 - HAY MULCH SHALL BE APPLIED IMMEDIATELY AFTER SEEDING AS INDICATED ABOVE;
 - THE SURFACE SHALL BE WATERED AND KEPT MOIST WITH A FINE SPRAY AS REQUIRED, WITHOUT WASHING AWAY THE SOIL, UNTIL THE GRASS IS WELL ESTABLISHED. ANY AREAS WHICH ARE NOT SATISFACTORILY COVERED WITH GRASS SHALL BE RESEEDED, AND ALL NOXIOUS WEEDS REMOVED;
 - THE CONTRACTOR SHALL PROTECT AND MAINTAIN THE SEEDED AREAS UNTIL ACCEPTED;
 - A GRASS SEED MIXTURE CONTAINING THE FOLLOWING SEED REQUIREMENTS SHALL BE APPLIED AT THE INDICATED RATE:

SEED MIX	APPLICATION RATE
CREeping RED FESCUE	20 LBS/ACRE
TALL FESCUE	20 LBS/ACRE
REDTOP	2 LBS/ACRE

 IN NO CASE SHALL THE WEED CONTENT EXCEED ONE (1) PERCENT BY WEIGHT. ALL SEED SHALL COMPLY WITH STATE AND FEDERAL SEED LAWS. SEEDING SHALL BE DONE NO LATER THAN SEPTEMBER 15. IN NO CASE SHALL SEEDING TAKE PLACE OVER SNOW.
 - DORMANT SEEDING (SEPTEMBER 15 TO FIRST SNOWFALL):
 - FOLLOW PERMANENT MEASURES SLOPE, LIME, FERTILIZER AND GRADING REQUIREMENTS. APPLY SEED MIXTURE AT TWICE THE INDICATED RATE. APPLY MULCH AS INDICATED FOR PERMANENT MEASURES.

CONCRETE WASHOUT AREA:

- THE FOLLOWING ARE THE ONLY NON-STORMWATER DISCHARGES ALLOWED. ALL OTHER NON-STORMWATER DISCHARGES ARE PROHIBITED ON SITE:
 - THE CONCRETE DELIVERY TRUCKS SHALL, WHENEVER POSSIBLE, USE WASHOUT FACILITIES AT THEIR OWN PLANT OR DISPATCH FACILITY;
 - IF IT IS NECESSARY, SITE CONTRACTOR SHALL DESIGNATE SPECIFIC WASHOUT AREAS AND DESIGN FACILITIES TO HANDLE ANTICIPATED WASHOUT WATER;
 - CONTRACTOR SHALL LOCATE WASHOUT AREAS AT LEAST 150 FEET AWAY FROM STORM DRAINS, SWALES AND SURFACE WATERS OR DELINEATED WETLANDS;
 - INSPECT WASHOUT FACILITIES DAILY TO DETECT LEAKS OR TEARS AND TO IDENTIFY WHEN MATERIALS NEED TO BE REMOVED.

ALLOWABLE NON-STORMWATER DISCHARGES:

- FIRE-FIGHTING ACTIVITIES;
- FIRE HYDRANT FLUSHING;
- WATERS USED TO WASH VEHICLES WHERE DETERGENTS ARE NOT USED;
- WATER USED TO CONTROL DUST;
- POTABLE WATER INCLUDING UNCONTAMINATED WATER LINE FLUSHING;
- ROUTINE EXTERNAL BUILDING WASH DOWN WHERE DETERGENTS ARE NOT USED;
- PERMANENT WASH WATERS WHERE DETERGENTS ARE NOT USED;
- UNCONTAMINATED AIR CONDITIONING/COMPRESSOR CONDENSATION;
- UNCONTAMINATED GROUND WATER OR SPRING WATER;
- FOUNDATION OR FOOTING DRAINS WHICH ARE UNCONTAMINATED;
- LANDSCAPE IRRIGATION.

WASTE DISPOSAL:

- WASTE MATERIAL:
 - ALL WASTE MATERIALS SHALL BE COLLECTED AND STORED IN SECURELY LIDDED RECEPTACLES. ALL TRASH AND CONSTRUCTION DEBRIS FROM THE SITE SHALL BE DEPOSITED IN A DUMPSTER;
 - NO CONSTRUCTION WASTE MATERIALS SHALL BE BURIED ON SITE;
 - ALL PERSONNEL SHALL BE INSTRUCTED REGARDING THE CORRECT PROCEDURE FOR WASTE DISPOSAL BY THE SUPERINTENDENT.
- HAZARDOUS WASTE:
 - ALL HAZARDOUS WASTE MATERIALS SHALL BE DISPOSED OF IN THE MANNER SPECIFIED BY LOCAL OR STATE REGULATION OR BY THE MANUFACTURER;
 - SITE PERSONNEL SHALL BE INSTRUCTED IN THESE PRACTICES BY THE SUPERINTENDENT.
- SANITARY WASTE:
 - ALL SANITARY WASTE SHALL BE COLLECTED FROM THE PORTABLE UNITS A MINIMUM OF ONCE PER WEEK BY A LICENSED SANITARY WASTE MANAGEMENT CONTRACTOR.

SPILL PREVENTION:

- CONTRACTOR SHALL BE FAMILIAR WITH SPILL PREVENTION MEASURES REQUIRED BY LOCAL, STATE AND FEDERAL AGENCIES. AT A MINIMUM, CONTRACTOR SHALL FOLLOW THE BEST MANAGEMENT SPILL PREVENTION PRACTICES OUTLINED BELOW.
- THE FOLLOWING ARE THE MATERIAL MANAGEMENT PRACTICES THAT SHALL BE USED TO REDUCE THE RISK OF SPILLS OR OTHER ACCIDENTAL EXPOSURE OF MATERIALS AND SUBSTANCES DURING CONSTRUCTION TO STORMWATER RUNOFF:
 - GOOD HOUSEKEEPING - THE FOLLOWING GOOD HOUSEKEEPING PRACTICE SHALL BE FOLLOWED ON SITE DURING CONSTRUCTION:
 - ONLY SUFFICIENT AMOUNTS OF PRODUCTS TO DO THE JOB SHALL BE STORED ON SITE;
 - ALL MATERIALS STORED ON SITE SHALL BE STORED IN A NEAT, ORDERLY MANNER IN THEIR PROPER (ORIGINAL IF POSSIBLE) CONTAINERS AND, IF POSSIBLE, UNDER A ROOF OR OTHER ENCLOSURE;
 - MANUFACTURER'S RECOMMENDATIONS FOR PROPER USE AND DISPOSAL SHALL BE FOLLOWED;
 - THE SITE SUPERINTENDENT SHALL INSPECT DAILY TO ENSURE PROPER USE AND DISPOSAL OF MATERIALS;
 - SUBSTANCES SHALL NOT BE MIXED WITH ONE ANOTHER UNLESS RECOMMENDED BY THE MANUFACTURER;
 - WHENEVER POSSIBLE ALL OF A PRODUCT SHALL BE USED UP BEFORE DISPOSING OF THE CONTAINER.
 - HAZARDOUS PRODUCTS - THE FOLLOWING PRACTICES SHALL BE USED TO REDUCE THE RISKS ASSOCIATED WITH HAZARDOUS MATERIALS:
 - PRODUCTS SHALL BE KEPT IN THEIR ORIGINAL CONTAINERS UNLESS THEY ARE NOT RESEALABLE;
 - ORIGINAL LABELS AND MATERIAL SAFETY DATA SHALL BE RETAINED FOR IMPORTANT PRODUCT INFORMATION;
 - SURPLUS PRODUCT THAT MUST BE DISPOSED OF SHALL BE DISCARDED ACCORDING TO THE MANUFACTURER'S RECOMMENDED METHODS OF DISPOSAL.
 - PRODUCT SPECIFIC PRACTICES - THE FOLLOWING PRODUCT SPECIFIC PRACTICES SHALL BE FOLLOWED ON SITE:
 - PETROLEUM PRODUCTS:
 - ALL ON SITE VEHICLES SHALL BE MONITORED FOR LEAKS AND RECEIVE REGULAR PREVENTIVE MAINTENANCE TO REDUCE LEAKAGE;
 - PETROLEUM PRODUCTS SHALL BE STORED IN TIGHTLY SEALED CONTAINERS WHICH ARE CLEARLY LABELED. ANY ASPHALT BASED SUBSTANCES USED ON SITE SHALL BE APPLIED ACCORDING TO THE MANUFACTURER'S RECOMMENDATIONS.
 - FERTILIZERS:
 - FERTILIZERS USED SHALL BE APPLIED ONLY IN THE MINIMUM AMOUNTS DIRECTED BY THE SPECIFICATIONS;
 - ONCE APPLIED FERTILIZER SHALL BE WORKED INTO THE SOIL TO LIMIT EXPOSURE TO STORMWATER;
 - STORAGE SHALL BE IN A COVERED SHED OR ENCLOSED TRAILERS. THE CONTENTS OF ANY PARTIALLY USED BAGS OF FERTILIZER SHALL BE TRANSFERRED TO A SEALABLE PLASTIC BIN TO AVOID SPILLS.
 - PAINTS:
 - ALL CONTAINERS SHALL BE TIGHTLY SEALED AND STORED WHEN NOT REQUIRED FOR USE;
 - EXCESS PAINT SHALL NOT BE DISCHARGED TO THE STORM SEWER SYSTEM;
 - EXCESS PAINT SHALL BE DISPOSED OF PROPERLY ACCORDING TO MANUFACTURER'S INSTRUCTIONS OR STATE AND LOCAL REGULATIONS.
 - SPILL CONTROL PRACTICES - IN ADDITION TO GOOD HOUSEKEEPING AND MATERIAL MANAGEMENT PRACTICES DISCUSSED IN THE PREVIOUS SECTION, THE FOLLOWING PRACTICES SHALL BE FOLLOWED FOR SPILL PREVENTION AND CLEANUP:
 - MANUFACTURER'S RECOMMENDED METHODS FOR SPILL CLEANUP SHALL BE CLEARLY POSTED AND SITE PERSONNEL SHALL BE MADE AWARE OF THE PROCEDURES AND THE LOCATION OF THE INFORMATION AND CLEANUP SUPPLIES;
 - MATERIALS AND EQUIPMENT NECESSARY FOR SPILL CLEANUP SHALL BE KEPT IN THE MATERIAL STORAGE AREA ON SITE. EQUIPMENT AND MATERIALS SHALL INCLUDE BUT NOT BE LIMITED TO BROOMS, DUSTPANS, MOPS, RAGS, GLOVES, GOGGLES, KITTY LITTER, SAND, SAWDUST AND PLASTIC OR METAL TRASH CONTAINERS SPECIFICALLY FOR THIS PURPOSE;
 - ALL SPILLS SHALL BE CLEANED UP IMMEDIATELY AFTER DISCOVERY AND REPORTED TO PEASE DEVELOPMENT AUTHORITY;
 - THE SPILL AREA SHALL BE KEPT WELL VENTILATED AND PERSONNEL SHALL WEAR APPROPRIATE PROTECTIVE CLOTHING TO PREVENT INJURY FROM CONTACT WITH A HAZARDOUS SUBSTANCE;
 - SPILLS OF TOXIC OR HAZARDOUS MATERIAL SHALL BE REPORTED TO THE APPROPRIATE LOCAL, STATE OR FEDERAL AGENCIES AS REQUIRED;
 - THE SITE SUPERINTENDENT RESPONSIBLE FOR DAY-TO-DAY SITE OPERATIONS SHALL BE THE SPILL PREVENTION AND CLEANUP COORDINATOR.
 - VEHICLE FUELING AND MAINTENANCE PRACTICE:
 - CONTRACTOR SHALL MAKE AN EFFORT TO PERFORM EQUIPMENT/VEHICLE FUELING AND MAINTENANCE AT AN OFF-SITE FACILITY;
 - CONTRACTOR SHALL PROVIDE AN ON-SITE FUELING AND MAINTENANCE AREA THAT IS CLEAN AND DRY;
 - IF POSSIBLE THE CONTRACTOR SHALL KEEP AREA COVERED;
 - CONTRACTOR SHALL KEEP A SPILL KIT AT THE FUELING AND MAINTENANCE AREA;
 - CONTRACTOR SHALL REGULARLY INSPECT VEHICLES FOR LEAKS AND DAMAGE;
 - CONTRACTOR SHALL USE DRIP PANS, DRIP CLOTHS, OR ABSORBENT PADS WHEN REPLACING SPENT FLUID.

EROSION CONTROL OBSERVATIONS AND MAINTENANCE PRACTICES

THIS PROJECT EXCEEDS ONE (1) ACRE OF DISTURBANCE AND THUS REQUIRES A SWPPP.

THE FOLLOWING REPRESENTS THE GENERAL OBSERVATION AND REPORTING PRACTICES THAT SHALL BE FOLLOWED AS PART OF THIS PROJECT:

- AN OBSERVATION REPORT SHALL BE MADE AFTER EACH OBSERVATION AND DISTRIBUTED TO THE ENGINEER, THE OWNER, AND THE CONTRACTOR;
- A REPRESENTATIVE OF THE SITE CONTRACTOR, SHALL BE RESPONSIBLE FOR MAINTENANCE AND REPAIR ACTIVITIES;
- IF A REPAIR IS NECESSARY, IT SHALL BE INITIATED WITHIN 24 HOURS OF REPORT;
- AN NPDES NOTICE OF INTENT SHALL BE SUBMITTED.



- NOTES:
- CONCRETE WASHOUT SHALL BE "JESCRAFT" STACKABLE CONCRETE WASHOUT PAN (72"x72"x1.4") OR APPROVED EQUAL.
 - INSTALL AND MAINTAIN CONCRETE WASHOUT IN ACCORDANCE WITH MANUFACTURER'S SPECIFICATIONS.
 - CONCRETE WASHOUT SHALL NOT BE PLACED WITHIN 100' WETLAND BUFFER.

CONCRETE WASHOUT DETAIL
NO SCALE

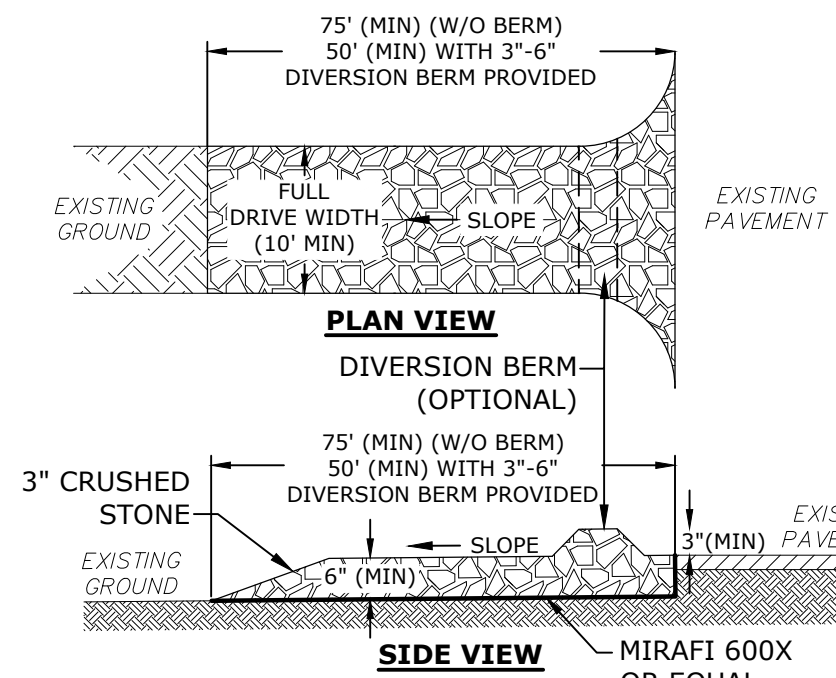

- NOTES:
- THE ENTRANCE SHALL BE MAINTAINED IN A CONDITION WHICH WILL PREVENT TRACKING OF SEDIMENT FROM THE SITE. WHEN WASHING IS REQUIRED, IT SHALL BE DONE SO RUNOFF DRAINS INTO AN APPROVED SEDIMENT TRAPPING DEVICE. ALL SEDIMENT SHALL BE PREVENTED FROM ENTERING STORM DRAINS, DITCHES, OR WATERWAYS

STABILIZED CONSTRUCTION EXIT
NO SCALE

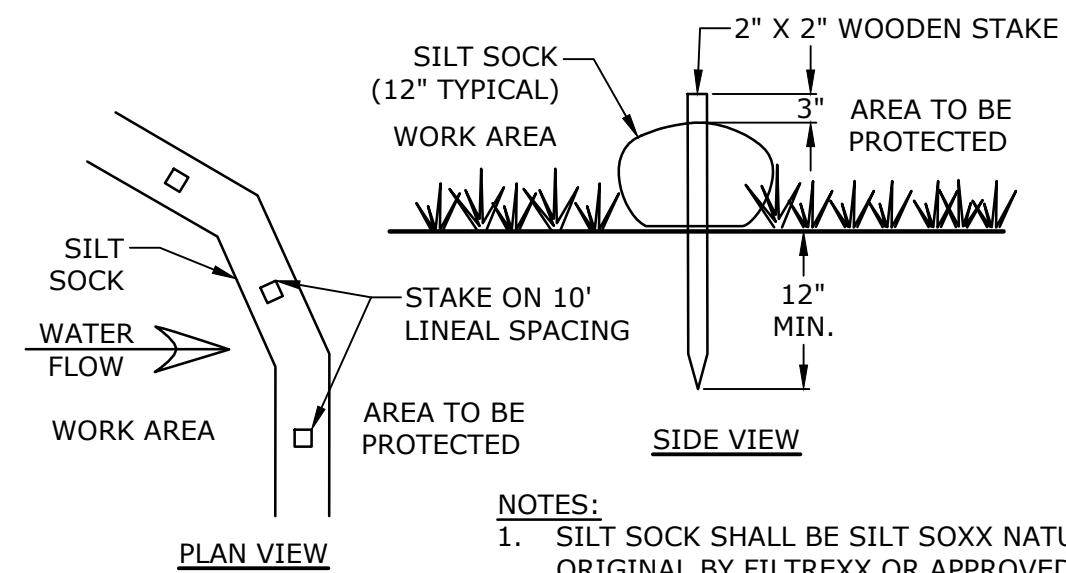

- NOTES:
- SILT SOCK SHALL BE SILT SOCK NATURAL ORIGINAL BY FILTREXX OR APPROVED EQUAL.
 - INSTALL SILT SOCK IN ACCORDANCE WITH MANUFACTURER'S SPECIFICATIONS.

SILT SOCK
NO SCALE

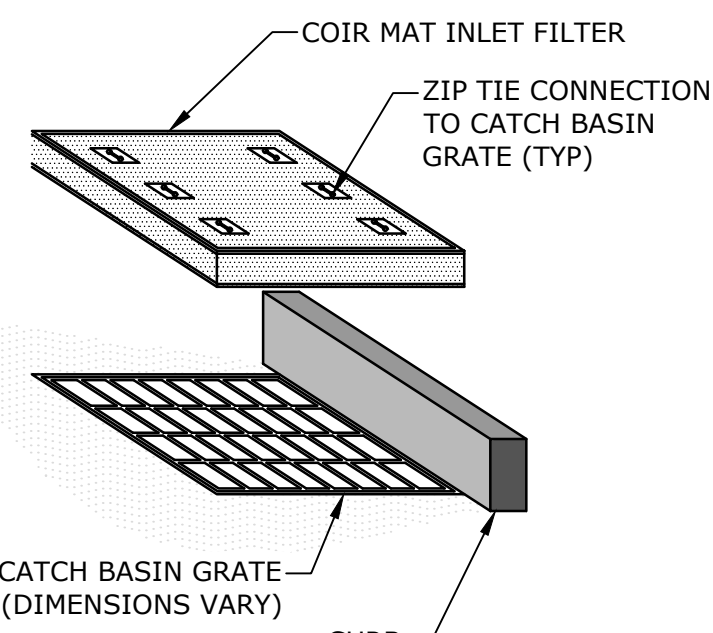

- NOTES:
- COIR MAT INLET FILTER SHALL BE STORM WATER INLET FILTER BY BLOCKSOM & CO. OR APPROVED EQUAL.
 - INSTALL AND MAINTAIN INLET PROTECTION IN ACCORDANCE WITH MANUFACTURER'S SPECIFICATIONS.

INLET PROTECTION
NO SCALE

PROPOSED DEVELOPMENT

PROSPECT NORTH 815, LLC

815 LAFAYETTE ROAD
PORTSMOUTH, NEW HAMPSHIRE

MARK	DATE	DESCRIPTION
PROJECT NO:	M5131-001	
DATE:	9/5/2023	
FILE:	M5131-001-DTLS.dwg	
DRAWN BY:	NHW/CLK	
DESIGNED/CHECKED BY:	NAH	
APPROVED BY:	PMC	

EROSION CONTROL NOTES & DETAILS

SCALE: AS SHOWN

MARK	DATE	DESCRIPTION
PROJECT NO:	M5131-001	
DATE:	9/5/2023	
FILE:	M5131-001-DTLS.dwg	
DRAWN BY:	NHW/CJK	
DESIGNED/CHECKED BY:	NAH	
APPROVED BY:	PMC	

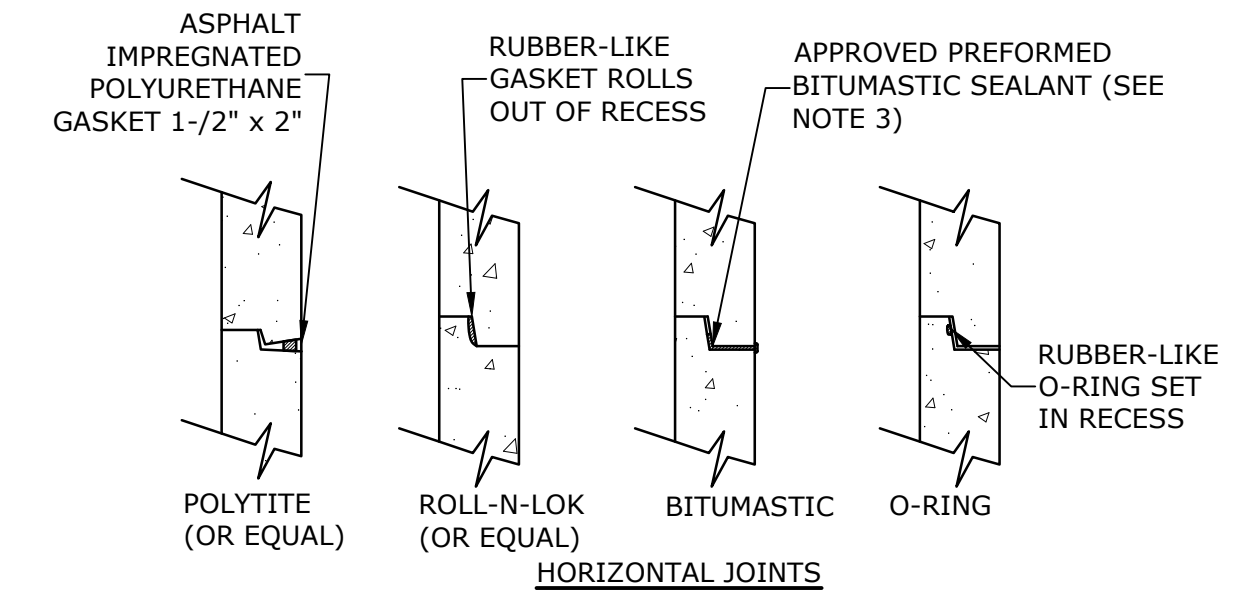
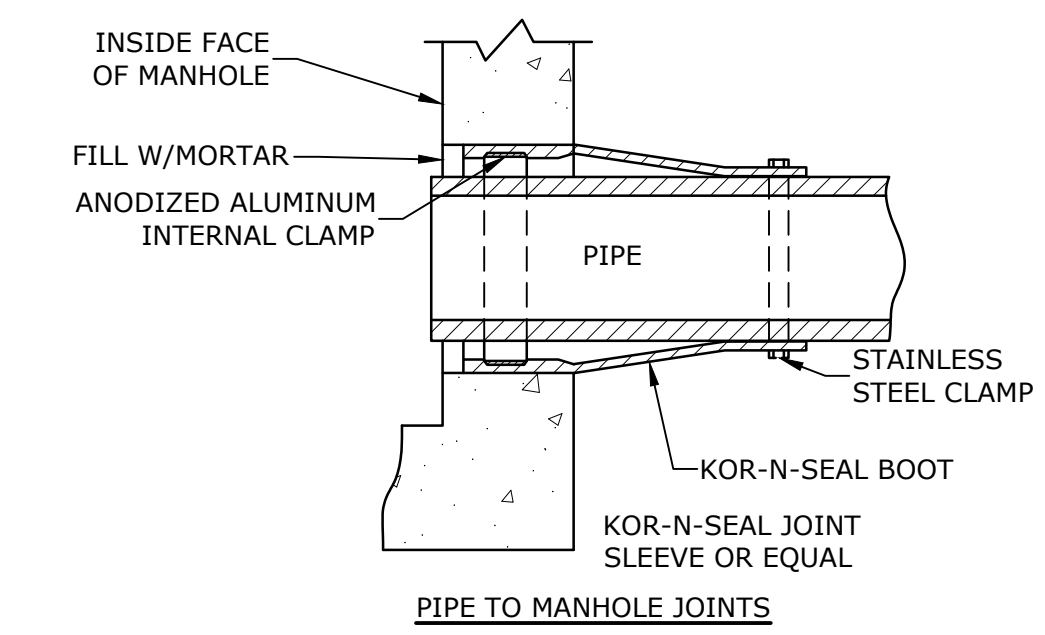

- NOTES:
- HORIZONTAL JOINTS BETWEEN THE SECTIONS OF PRECAST CONCRETE BARRELS SHALL BE PER CITY OF DOVER COMMUNITY DEVELOPMENT DEPARTMENT STANDARDS AND SHALL BE SEALED FOR WATERTIGHTNESS USING A DOUBLE ROW ELASTOMERIC OR MASTIC-LIKE GASKET.
 - PIPE TO MANHOLE JOINTS SHALL BE PER CITY OF DOVER STANDARDS.
 - FOR BITUMASTIC TYPE JOINTS THE AMOUNT OF SEALANT SHALL BE SUFFICIENT TO FILL AT LEAST 75% OF THE JOINT CAVITY.
 - ALL GASKETS, SEALANTS, MORTAR, ETC. SHALL BE INSTALLED IN ACCORDANCE WITH MANUFACTURERS' WRITTEN INSTRUCTIONS.

MANHOLE JOINTS
NO SCALE

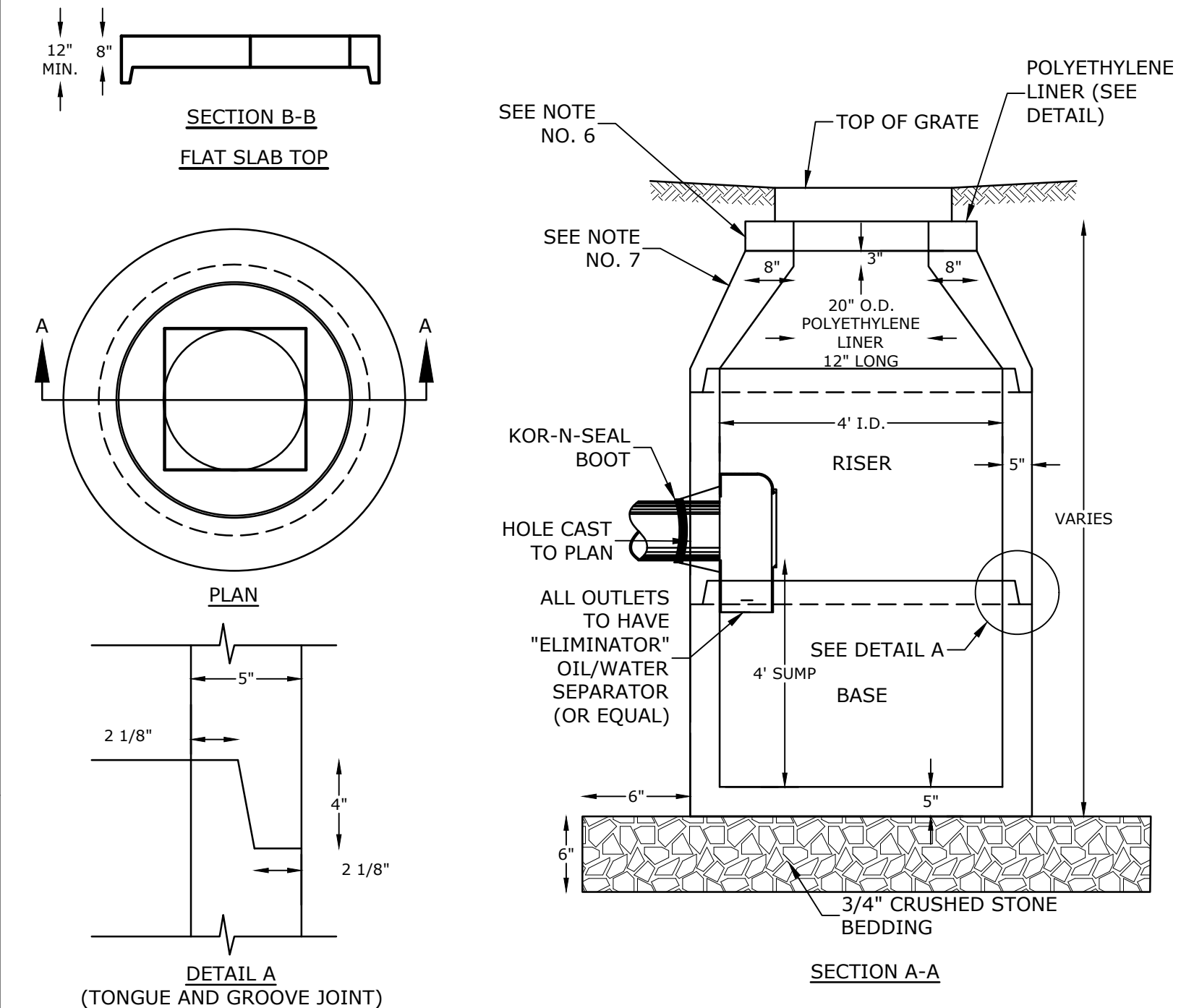

4' DIAMETER CATCHBASIN
NO SCALE

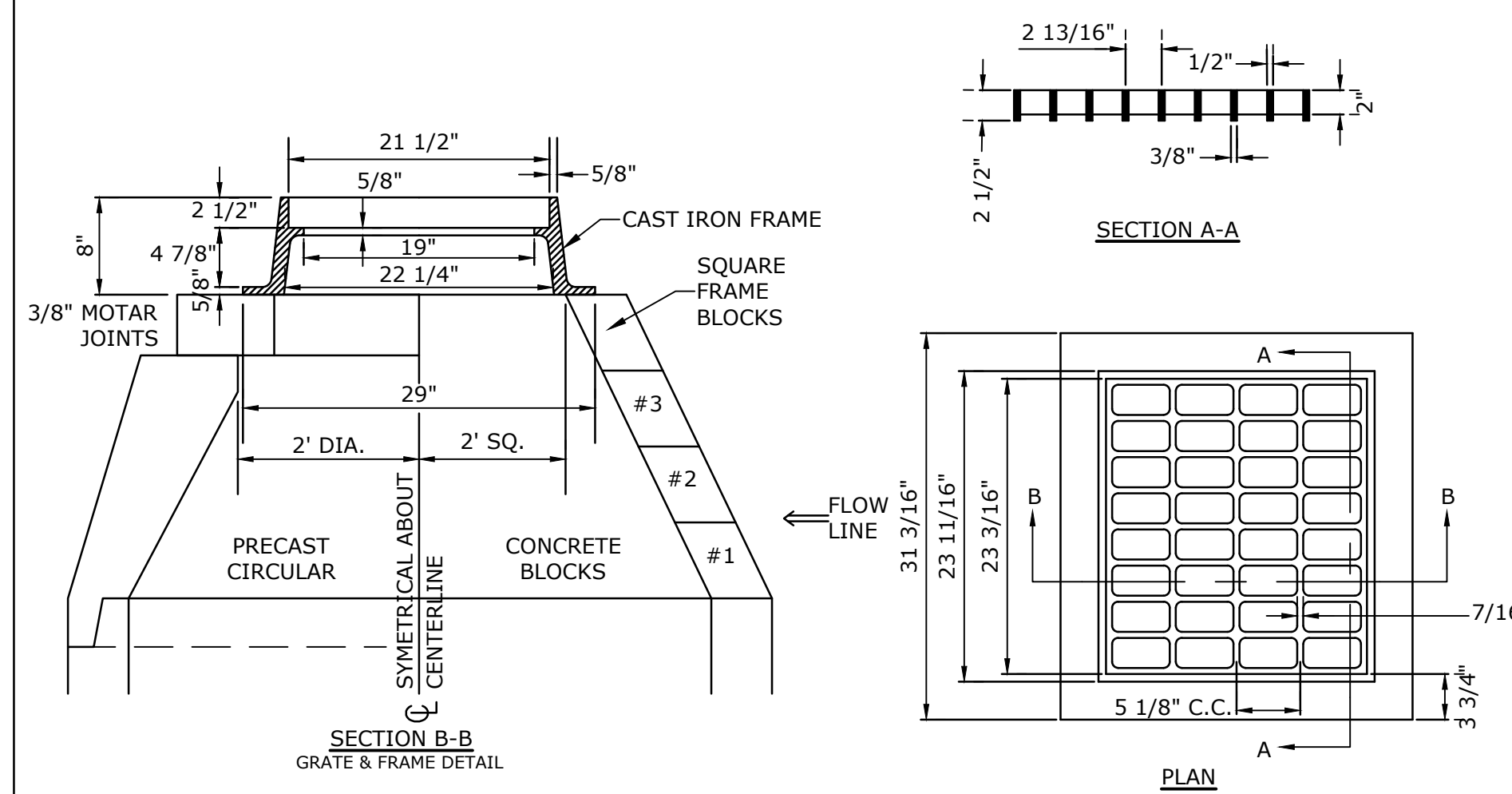

CATCH BASIN FRAME & GRATE
NO SCALE

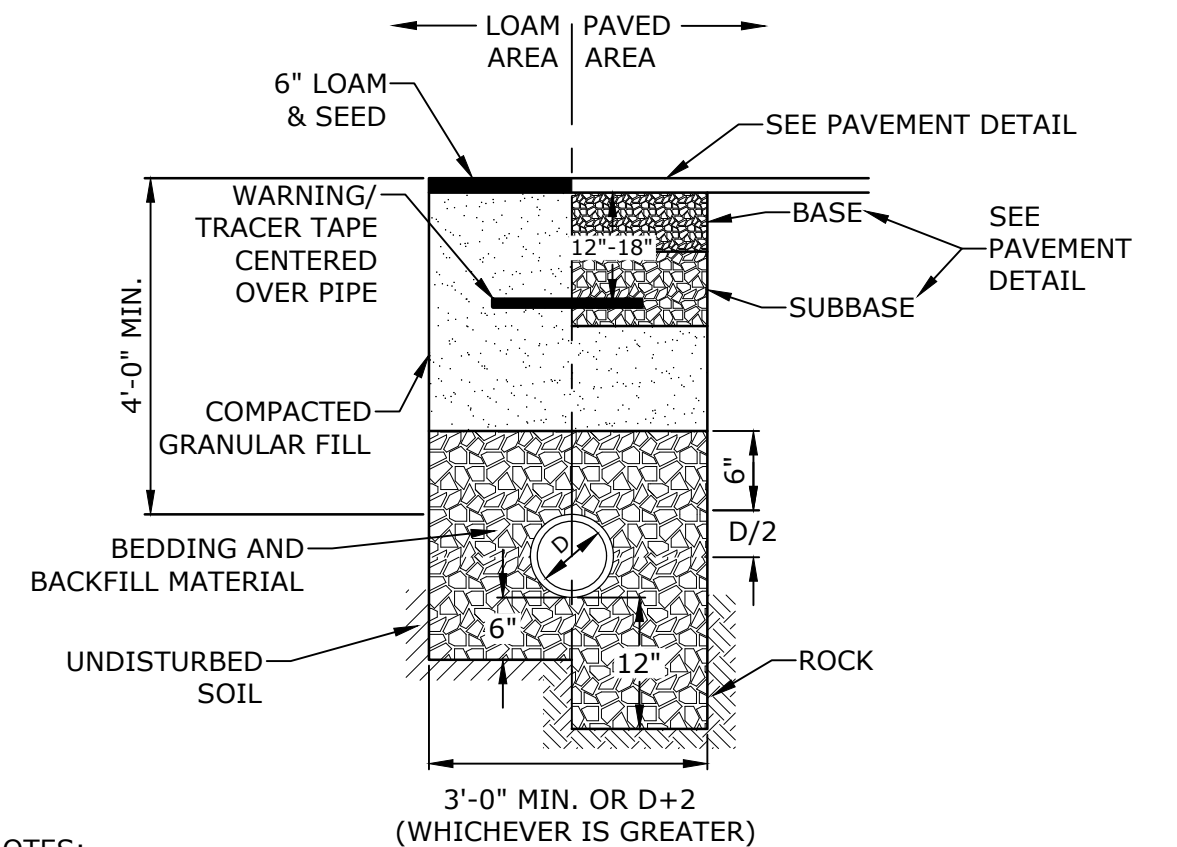

- NOTES:
- CRUSHED STONE BEDDING AND BACKFILL FOR FULL WIDTH OF THE TRENCH FROM 6" BELOW PIPE IN EARTH AND 12" BELOW PIPE IN ROCK UP TO 6" ABOVE TOP OF PIPE.
 - ALL UTILITIES SHALL BE INSTALLED PER THE INDIVIDUAL UTILITY COMPANY STANDARDS. COORDINATE ALL INSTALLATIONS WITH INDIVIDUAL UTILITY COMPANIES AND THE CITY OF PORTSMOUTH.
 - DRAIN LINE SHALL BE INSULATED WHERE THERE IS LESS THAN 6' OF COVER IN PAVED AREAS AND LESS THAN 4' OF COVER IN NON-PAVED AREAS.

STORM DRAIN TRENCH
NO SCALE

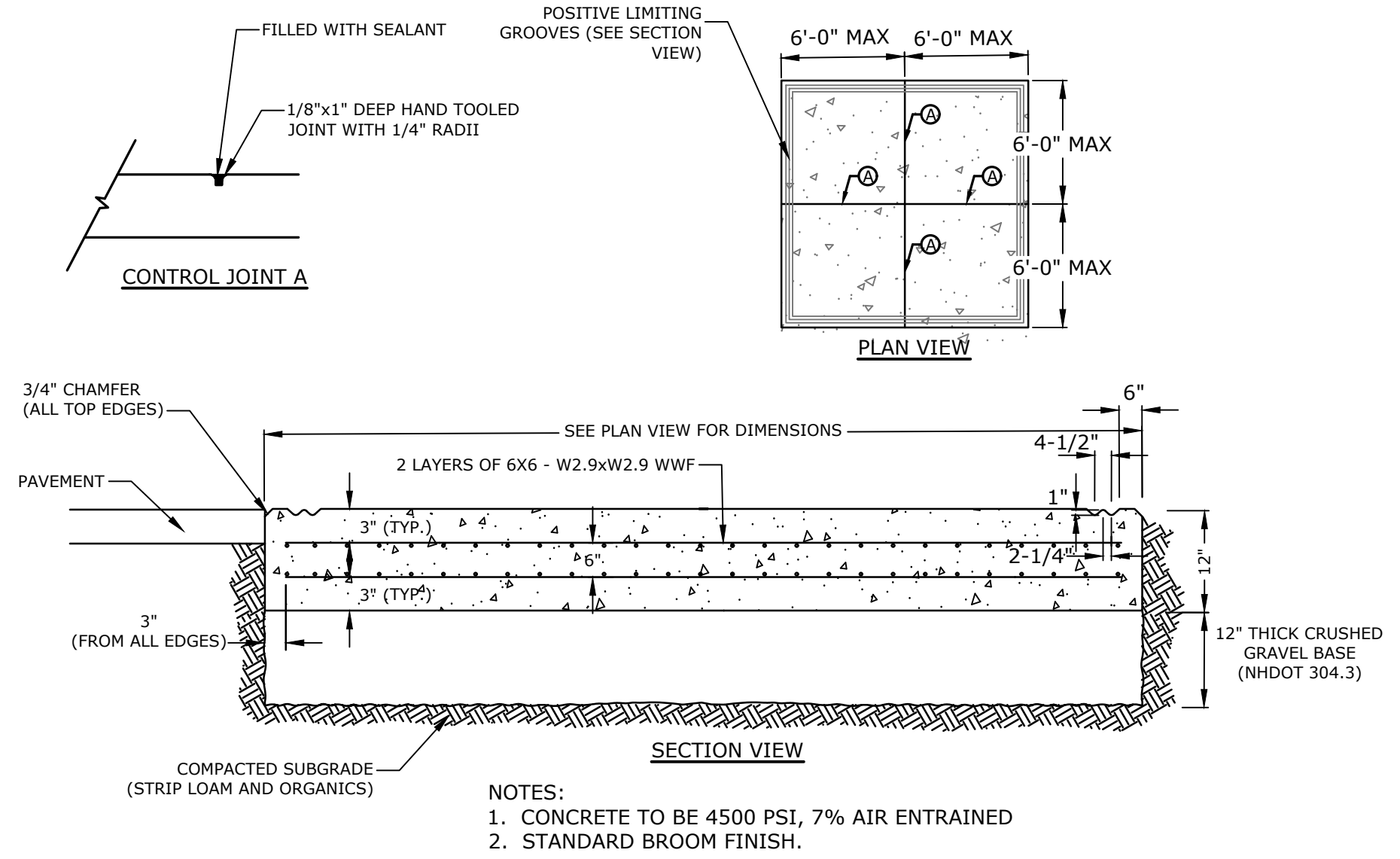

DUMPSTER PAD
NO SCALE

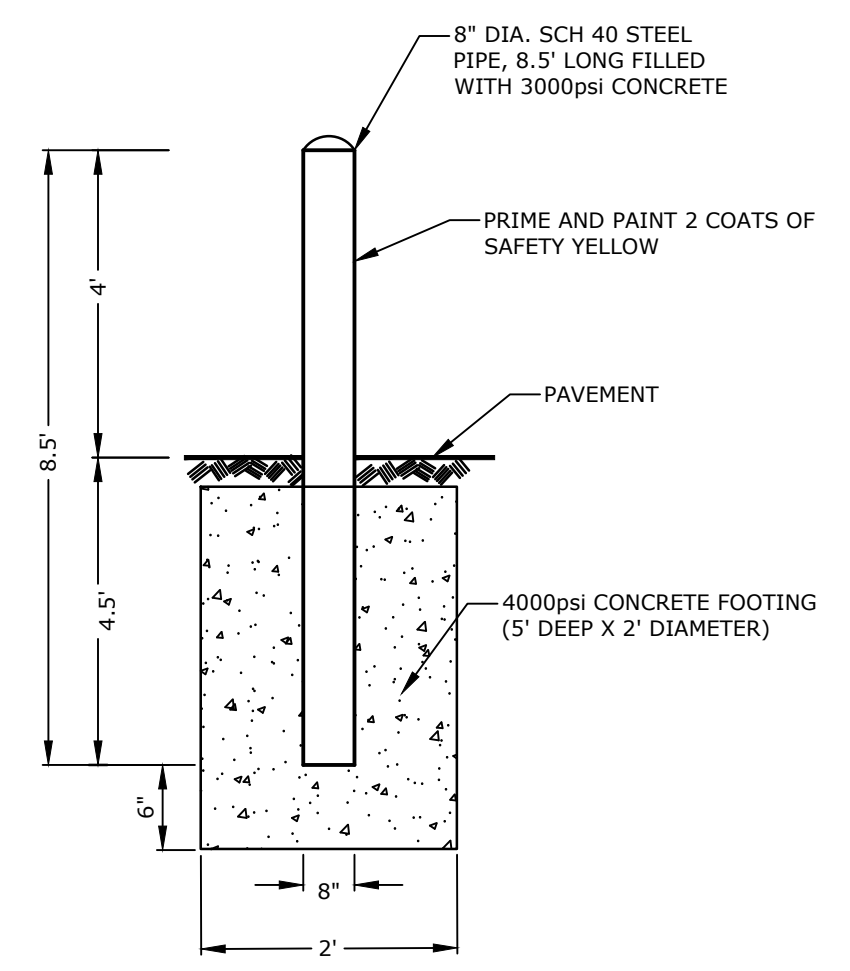

BOLLARD DETAIL
NO SCALE

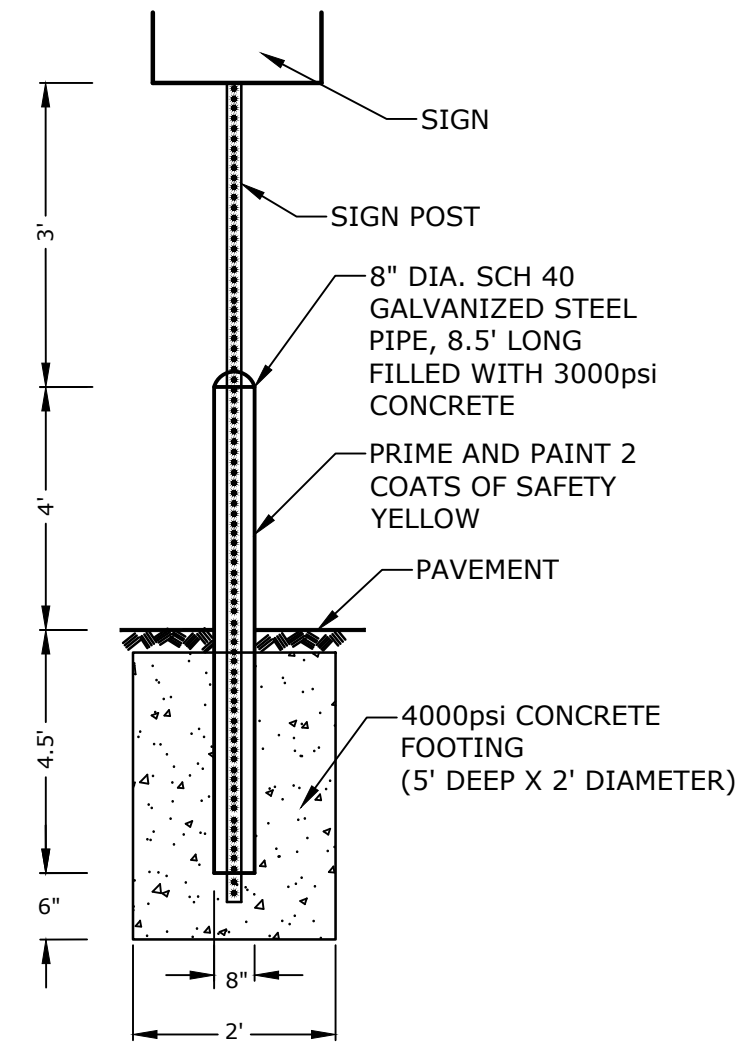

BOLLARD MOUNTED SIGN DETAIL
NO SCALE

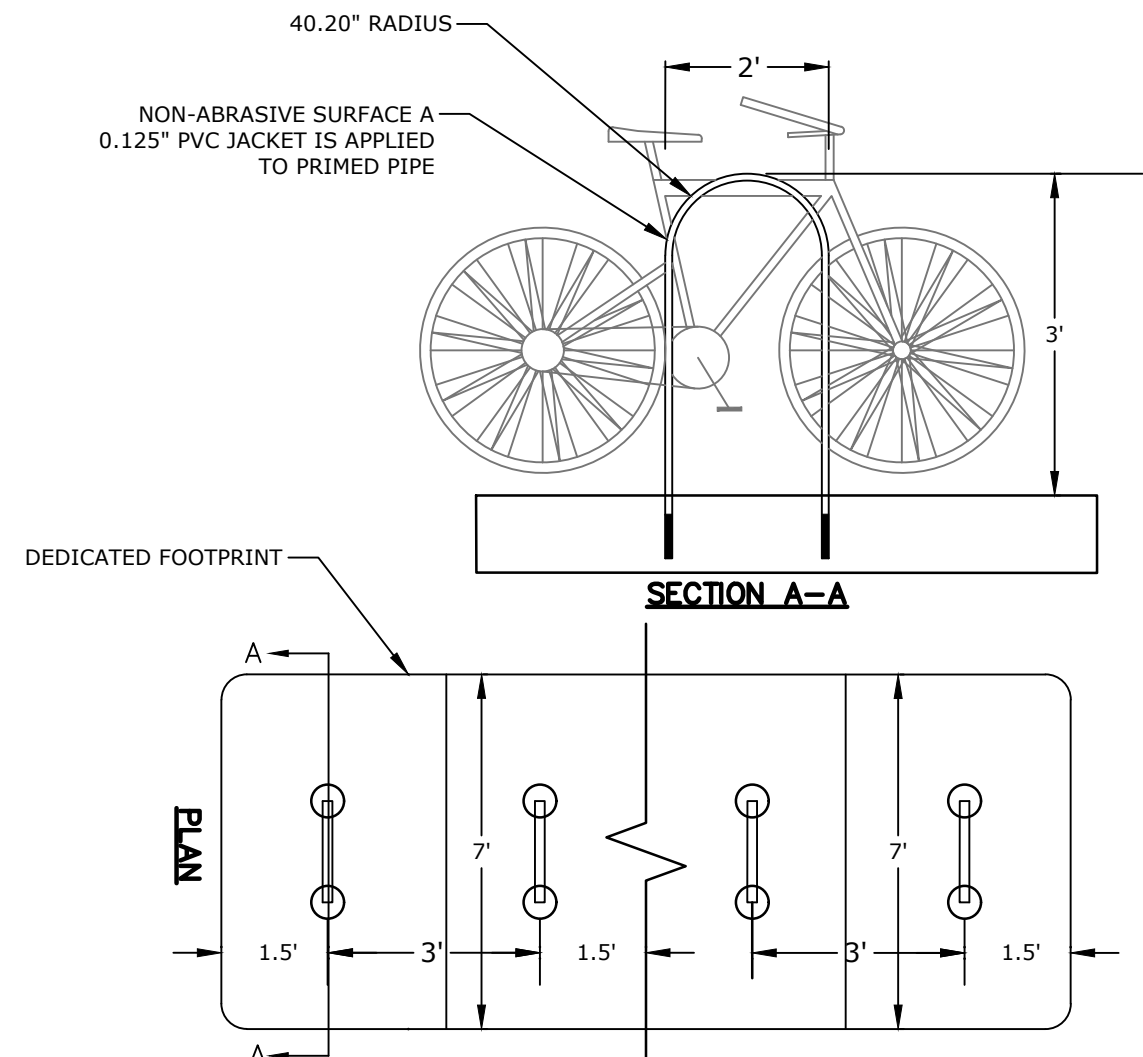

BIKE RACK
NO SCALE

Last Saved: 9/1/2023 8:04am By: Ckrzucik Plotted On: Sep 05, 2023 8:04am By: Ckrzucik Tighe & Bond 31.MW9331.HMZ Development, LLC 001 815 Lafayette Road Drawings\AutoCAD\M5131_001-DTLS.dwg

PROGRESS PRINT

PROPOSED DEVELOPMENT

PROSPECT NORTH 815, LLC

815 LAFAYETTE ROAD
PORTSMOUTH, NEW HAMPSHIRE

MARK	DATE	DESCRIPTION
PROJECT NO:	M5131-001	
DATE:	9/5/2023	
FILE:	M5131-001-DTLS.dwg	
DRAWN BY:	NHW/CJK	
DESIGNED/CHECKED BY:	NAH	
APPROVED BY:	PMC	

DETAILS

SCALE: AS SHOWN

C-504

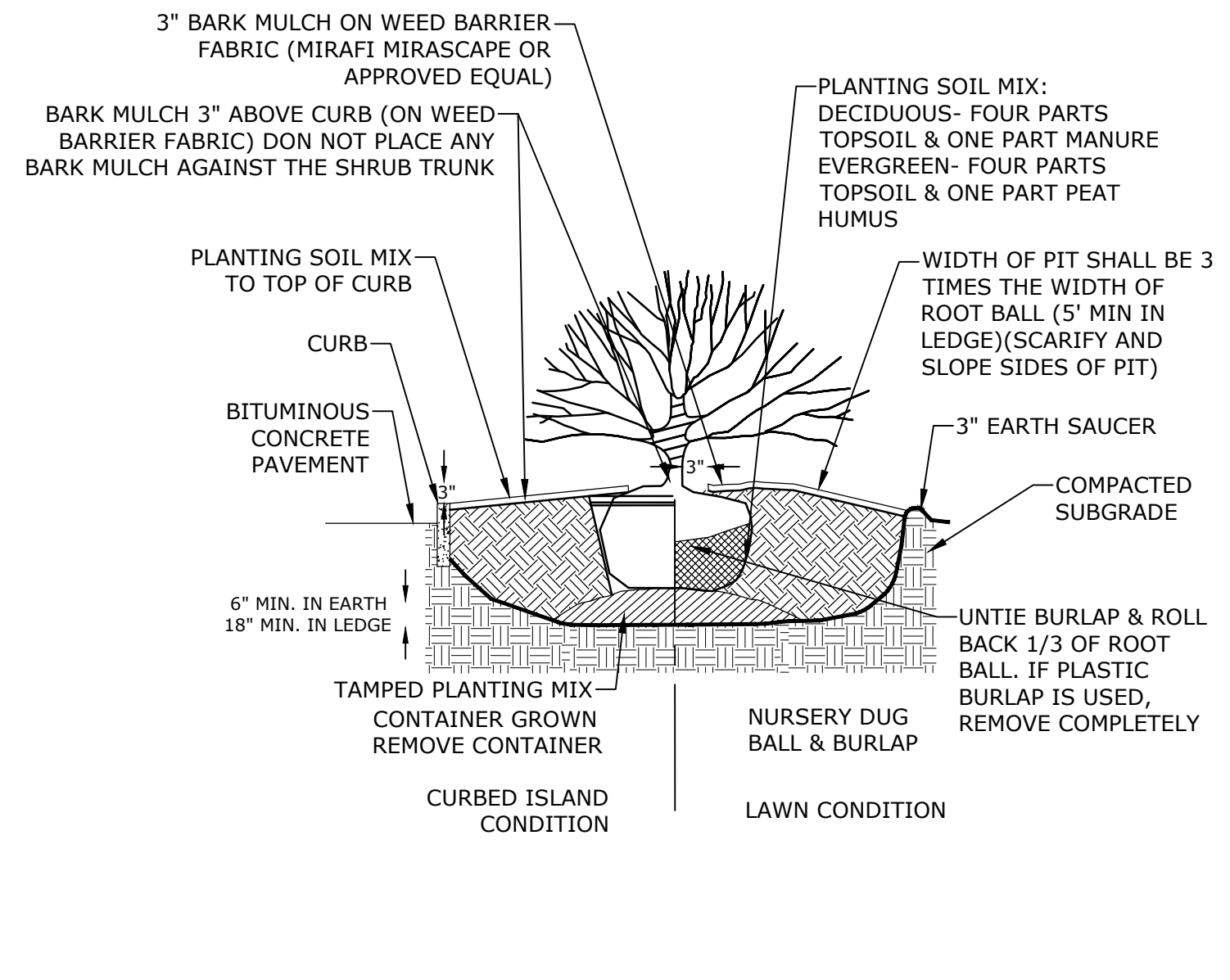

NOTE:
1. PLANT AT SAME DEPTH AS PREVIOUSLY PLANTED, OR WITHIN 2\"/>

SHRUB PLANTING
NO SCALE

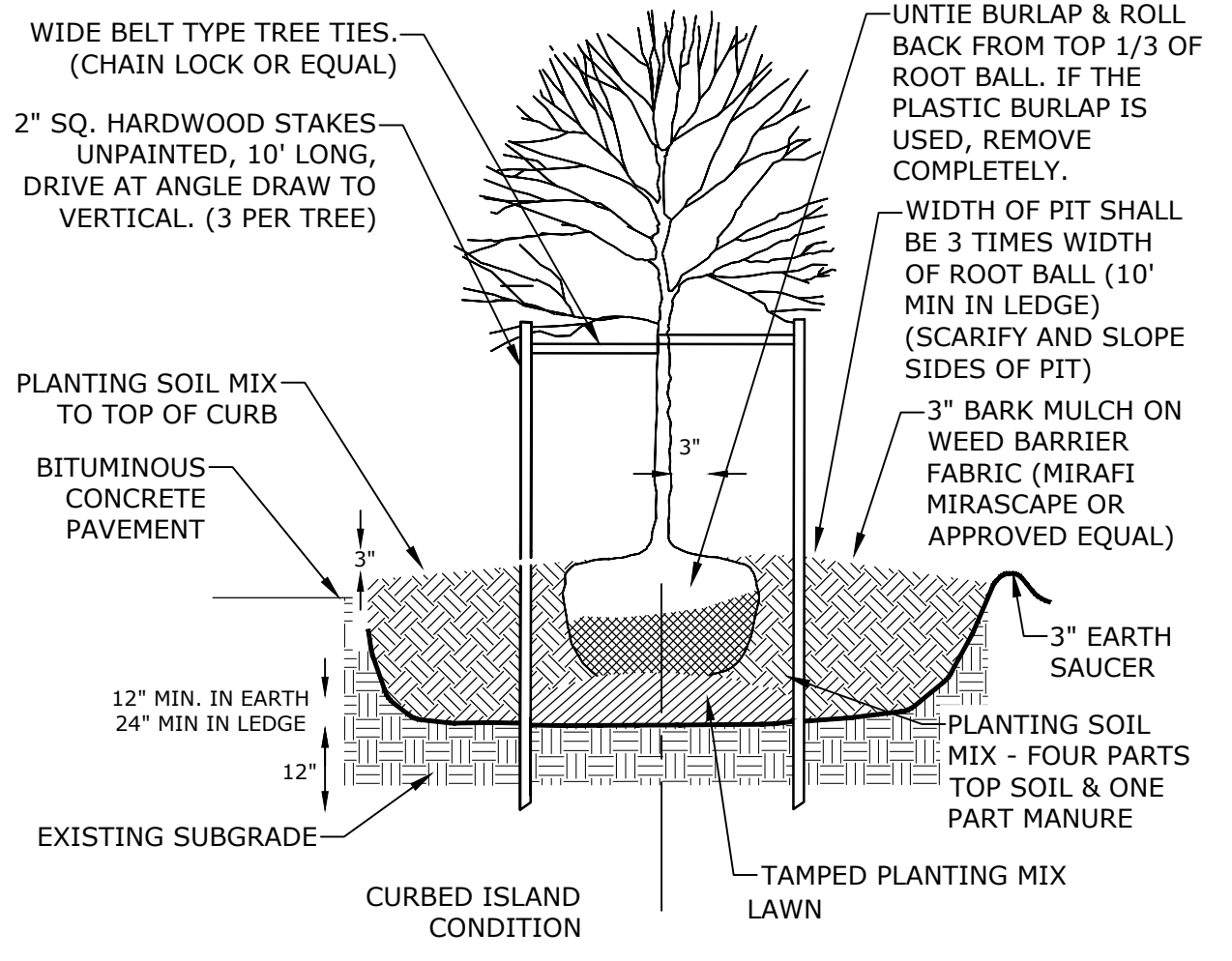

NOTES:
1. PLANT AT SAME DEPTH AS PREVIOUSLY PLANTED OR WITHIN 2\"/>

DECIDUOUS TREE PLANTING
NO SCALE

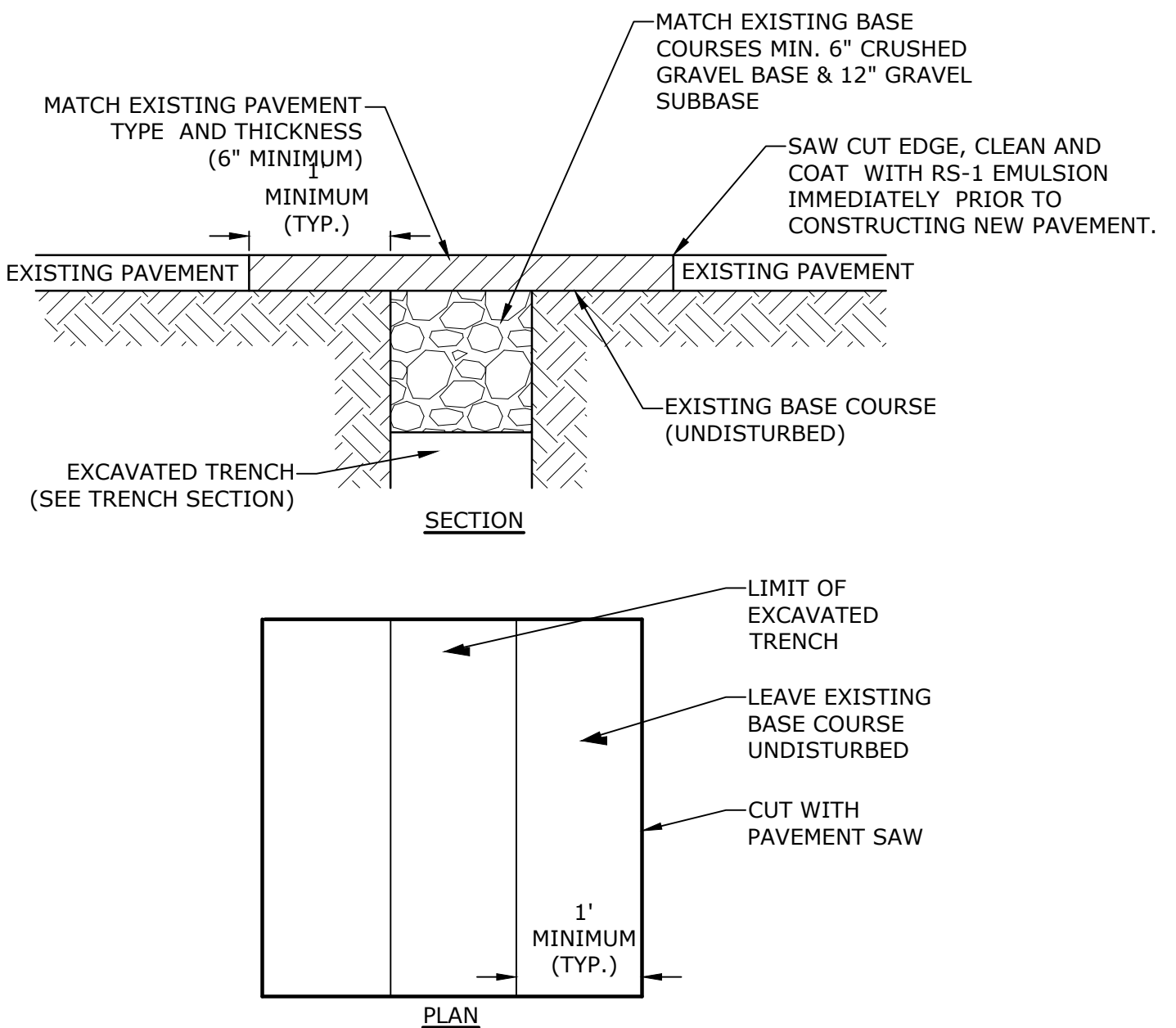

NOTE:
1. COORDINATE AND OBTAIN APPROVAL FOR ALL TRENCHING AND PATCHING WITHIN CITY RIGHT OF WAY WITH CITY OF PORTSMOUTH DPW PRIOR TO COMMENCING WORK.

ROADWAY TRENCH PATCH
NO SCALE

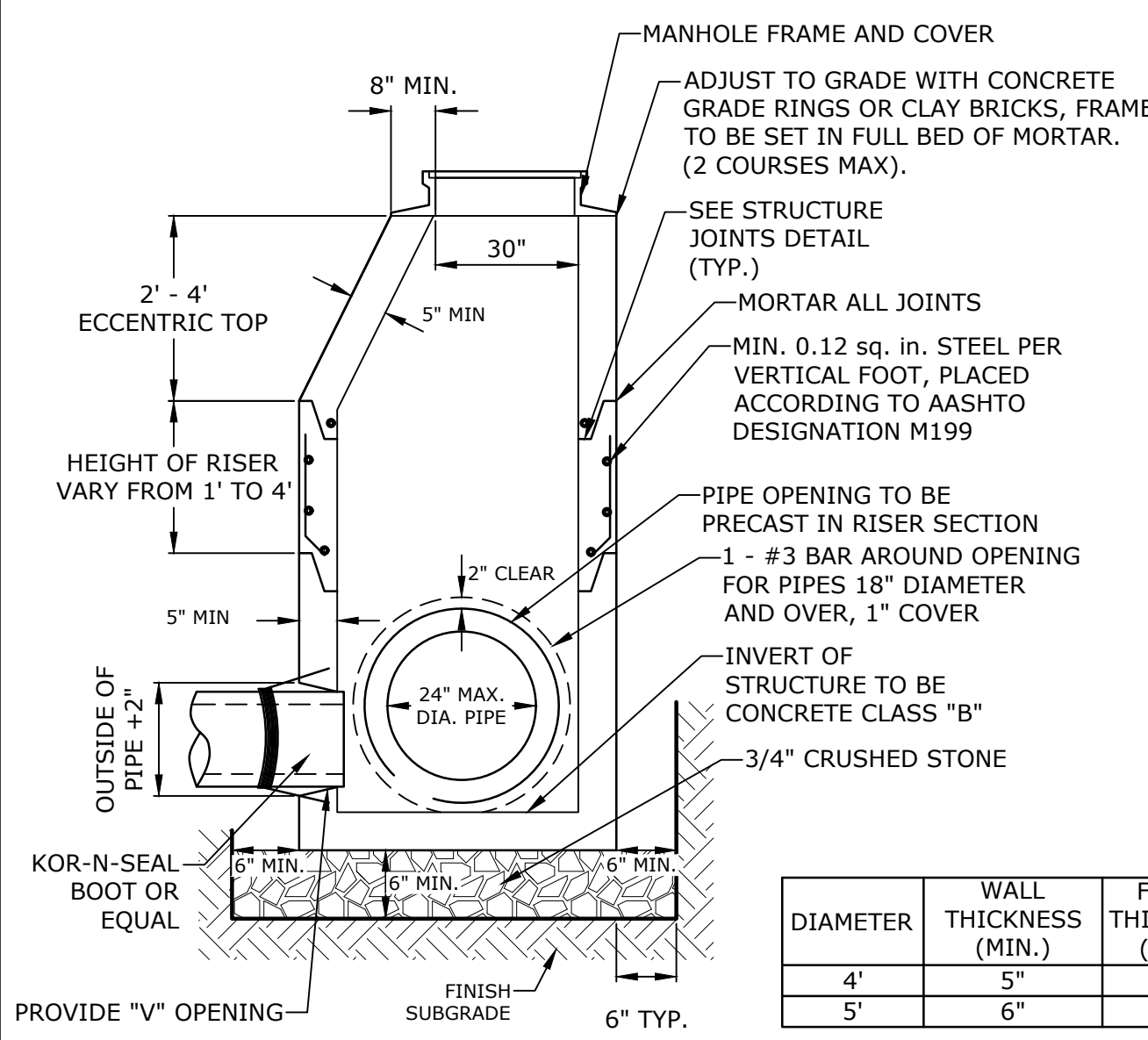

NOTES:
1. ALL SECTIONS SHALL BE 4,000 PSI CONCRETE.
2. CIRCUMFERENTIAL REINFORCEMENT SHALL BE 0.12 SQUARE INCHES PER LINEAR FOOT IN ALL SECTIONS AND SHALL BE PLACED IN THE CENTER THIRD OF THE WALL.
3. THE TONGUE AND GROOVE OF THE JOINT SHALL CONTAIN ONE LINE OF CIRCUMFERENTIAL REINFORCEMENT EQUAL TO 0.12 SQUARE INCHES PER LINEAR FOOT.
4. THE STRUCTURES SHALL BE DESIGNED FOR H20 LOADING.
5. CONSTRUCT CRUSHED STONE BEDDING AND BACKFILL UNDER (6\"/>

DIAMETER	WALL THICKNESS (MIN.)	FLOOR THICKNESS (MIN.)
4"	5"	6"
5"	6"	8"

CORE HOLE SIZE				
PIPE SIZE	RCP CORE HOLE DIA.		PLASTIC CORE HOLE DIA.	
	INCHES	FEET	INCHES	FEET
6	12	1.5	7	0.6
12	18	1.5	18	1.5
15	22	1.8	20	1.7
18	26	2.2	24	2.0
24	34	2.8	32	2.7
30	42	3.5	42	3.5

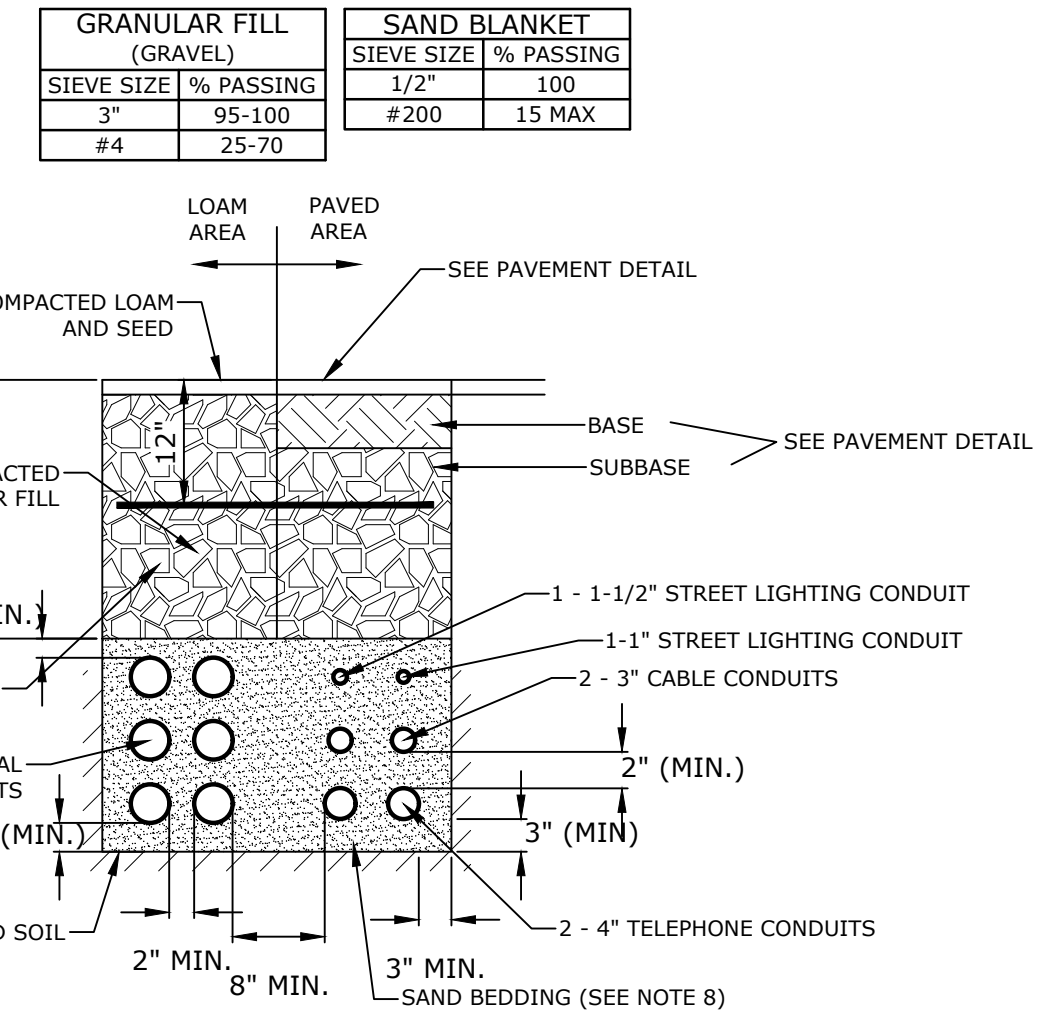

NOTE:
1. NUMBER, MATERIAL, AND SIZE OF UTILITY CONDUITS TO BE DETERMINED BY LOCAL UTILITY OR AS SHOWN ON ELECTRICAL DRAWINGS. CONTRACTOR TO PROVIDE ONE SPARE CONDUIT FOR EACH UTILITY TO BUILDING.
2. DIMENSIONS SHOWN REPRESENT OWNERS MINIMUM REQUIREMENTS. ACTUAL DIMENSIONS MAY BE GREATER BASED ON UTILITY COMPANY STANDARDS, BUT SHALL NOT BE LESS THAN THOSE SHOWN.
3. NO CONDUIT RUN SHALL EXCEED 360 DEGREES IN TOTAL BENDS.
4. A SUITABLE PULLING STRING, CAPABLE OF 200 POUNDS OF PULL, MUST BE INSTALLED IN THE CONDUIT BEFORE UTILITY COMPANY IS NOTIFIED TO INSTALL CABLE. THE STRING SHOULD BE BLOWN INTO THE CONDUIT AFTER THE RUN IS ASSEMBLED TO AVOID BONDING THE STRING TO THE CONDUIT.
5. UTILITY COMPANY MUST BE GIVEN THE OPPORTUNITY TO INSPECT THE CONDUIT PRIOR TO BACKFILL. THE CONTRACTOR IS RESPONSIBLE FOR ALL REPAIRS SHOULD THE UTILITY COMPANY BE UNABLE TO INSTALL ITS CABLE IN A SUITABLE MANNER.
6. ALL CONDUIT INSTALLATIONS MUST CONFORM TO THE CURRENT EDITION OF THE NATIONAL ELECTRIC SAFETY CODE, STATE AND LOCAL CODES AND ORDINANCES, AND, WHERE APPLICABLE, THE NATIONAL ELECTRIC CODE.
7. ALL 90° SWEEPS WILL BE MADE USING RIGID GALVANIZED STEEL SWEEPS WITH A 36 TO 48 INCH RADIUS.
8. SAND BEDDING TO BE REPLACED WITH CONCRETE ENCASEMENT WHERE COVER IS LESS THAN 3 FEET, WHEN LOCATED BELOW PAVEMENT, OR WHERE SHOWN ON THE UTILITIES PLAN.

ELECTRICAL AND COMMUNICATION CONDUIT
NO SCALE

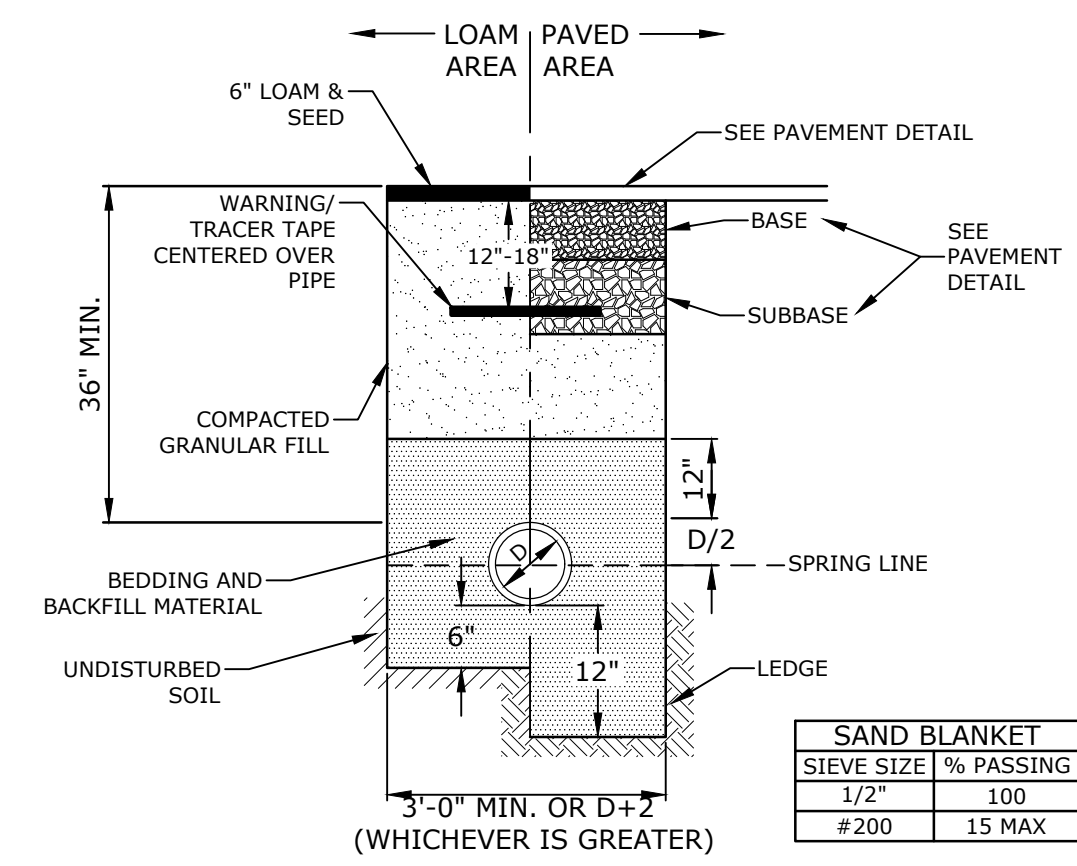

NOTE:
1. SAND BEDDING AND BACKFILL FOR FULL WIDTH OF THE TRENCH FROM 6\"/>

GAS TRENCH
NO SCALE

PROGRESS PRINT

PROPOSED DEVELOPMENT

PROSPECT NORTH 815, LLC

815 LAFAYETTE ROAD
PORTSMOUTH, NEW HAMPSHIRE

MARK	DATE	DESCRIPTION
PROJECT NO:	M5131-001	
DATE:	9/5/2023	
FILE:	M5131-001-DTLS.dwg	
DRAWN BY:	NHW/CJK	
DESIGNED/CHECKED BY:	NAH	
APPROVED BY:	PMC	

DETAILS

SCALE: AS SHOWN

C-505

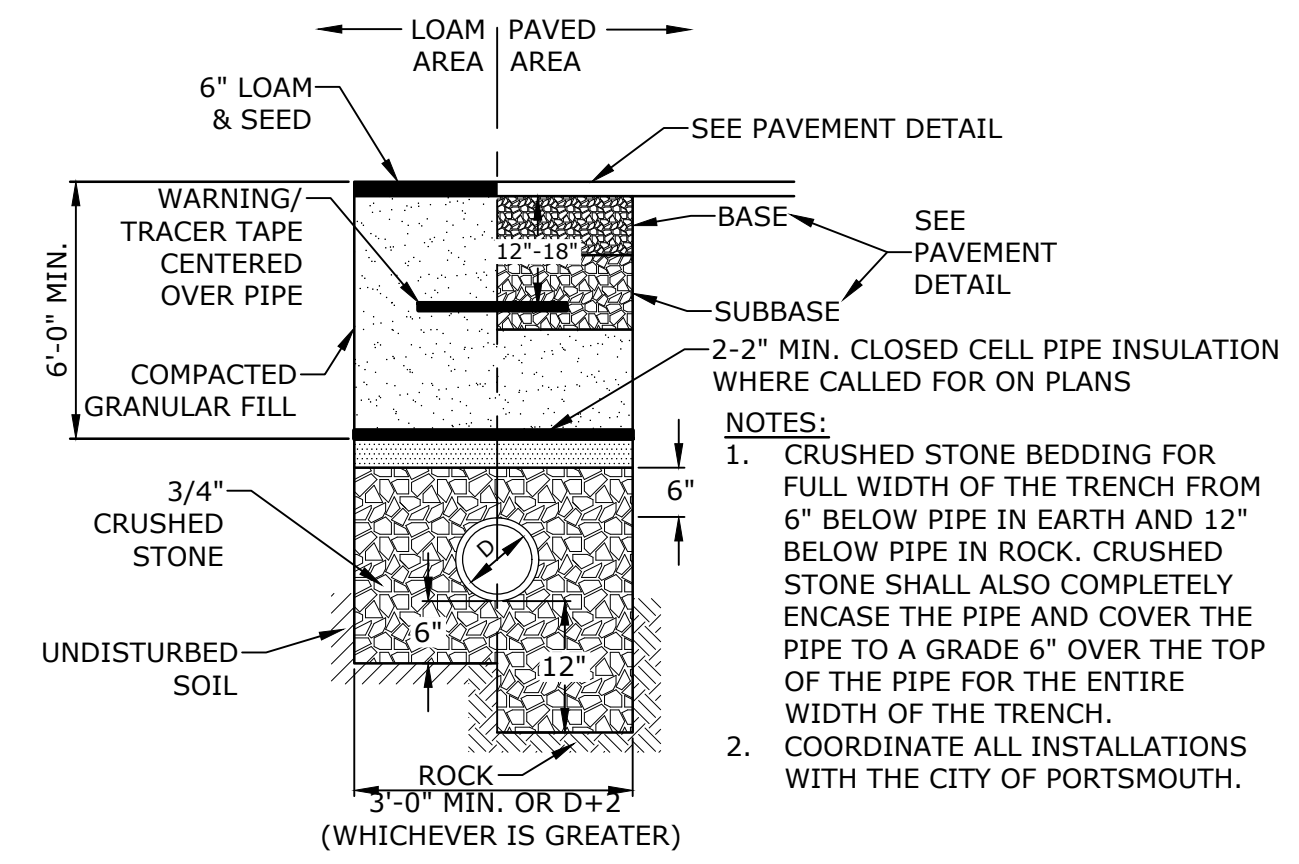

SEWER SERVICE TRENCH
NO SCALE

JELLYFISH DESIGN NOTES

JELLYFISH TREATMENT CAPACITY IS A FUNCTION OF THE CARTRIDGE LENGTH AND THE NUMBER OF CARTRIDGES. THE STANDARD SURFACE INLET STYLE WITH TRENCH GRATE AND COVER IS SHOWN. ALTERNATE CURB INLET OR PIPE INLET OPTIONS ARE AVAILABLE. PEAK CONVEYANCE CAPACITY TO BE DETERMINED BY ENGINEER OF RECORD.

CARTRIDGE SELECTION	54"	40"	27"	15"
CARTRIDGE LENGTH	54"	40"	27"	15"
OUTLET INVERT TO STRUCTURE INVERT (A)	6'-6"	5'-4"	4'-3"	3'-3"
FLOW RATE HIGH-FLO / DRAINDOWN (CFS) (PER CART)	0.178 / 0.089	0.133 / 0.067	0.089 / 0.045	0.049 / 0.025
MAX TREATMENT (CFS)	0.89	0.67	0.45	0.25
OUTLET INVERT TO RIM (MIN) (B)	3'-4"	3'-4"	3'-4"	3'-4"

STRUCTURE ID	01
WATER QUALITY FLOW RATE (cfs)	0.44
PEAK FLOW RATE (cfs)	3.57
RETURN PERIOD OF PEAK FLOW (yrs)	25
# OF CARTRIDGES REQUIRED (HF / DD)	2-1
CARTRIDGE LENGTH	54"

- GENERAL NOTES:**
- CONTECH TO PROVIDE ALL MATERIALS UNLESS NOTED OTHERWISE.
 - FOR SITE SPECIFIC DRAWINGS WITH DETAILED STRUCTURE DIMENSIONS AND WEIGHT, PLEASE CONTACT YOUR CONTECH ENGINEERED SOLUTIONS REPRESENTATIVE. www.ContechES.com
 - JELLYFISH WATER QUALITY STRUCTURE SHALL BE IN ACCORDANCE WITH ALL DESIGN DATA AND INFORMATION CONTAINED IN THIS DRAWING. CONTRACTOR TO CONFIRM STRUCTURE MEETS REQUIREMENTS OF PROJECT.
 - STRUCTURE SHALL MEET AASHTO HS-20 OR PER APPROVING JURISDICTION REQUIREMENTS, WHICHEVER IS MORE STRINGENT, ASSUMING EARTH COVER OF 7' AND GROUNDWATER ELEVATION AT OR BELOW THE OUTLET PIPE INVERT ELEVATION. ENGINEER OF RECORD TO CONFIRM ACTUAL GROUNDWATER ELEVATION. CASTINGS SHALL MEET AASHTO M306 LOAD RATING AND BE CAST WITH THE CONTECH LOGO.
 - STRUCTURE SHALL BE PRECAST CONCRETE CONFORMING TO ASTM C-857, ASTM C-918, AND AASHTO LOAD FACTOR DESIGN METHOD.
 - OUTLET PIPE INVERT IS EQUAL TO THE CARTRIDGE DECK ELEVATION.
 - THE OUTLET PIPE DIAMETER FOR NEW INSTALLATIONS IS RECOMMENDED TO BE ONE PIPE SIZE LARGER THAN THE INLET PIPE (WHERE APPLICABLE) AT EQUAL OR GREATER SLOPE.
 - NO PRODUCT SUBSTITUTIONS SHALL BE ACCEPTED UNLESS SUBMITTED 10 DAYS PRIOR TO PROJECT BID DATE, OR AS DIRECTED BY THE ENGINEER OF RECORD.

- INSTALLATION NOTES:**
- ANY SUB-BASE, BACKFILL DEPTH, AND/OR ANTI-FLOTATION PROVISIONS ARE SITE-SPECIFIC DESIGN CONSIDERATIONS AND SHALL BE SPECIFIED BY ENGINEER OF RECORD.
 - CONTRACTOR TO PROVIDE EQUIPMENT WITH SUFFICIENT LIFTING AND REACH CAPACITY TO LIFT AND SET THE STRUCTURE.
 - CONTRACTOR WILL INSTALL AND LEVEL THE STRUCTURE, SEALING THE JOINTS, LINE ENTRY AND EXIT POINTS (NON-SHRINK GROUT WITH APPROVED WATERSTOP OR FLEXIBLE BOOT).
 - CARTRIDGE INSTALLATION, BY CONTECH, SHALL OCCUR ONLY AFTER SITE HAS BEEN STABILIZED AND THE JELLYFISH UNIT IS CLEAN AND FREE OF DEBRIS. CONTACT CONTECH TO COORDINATE CARTRIDGE INSTALLATION WITH SITE STABILIZATION.

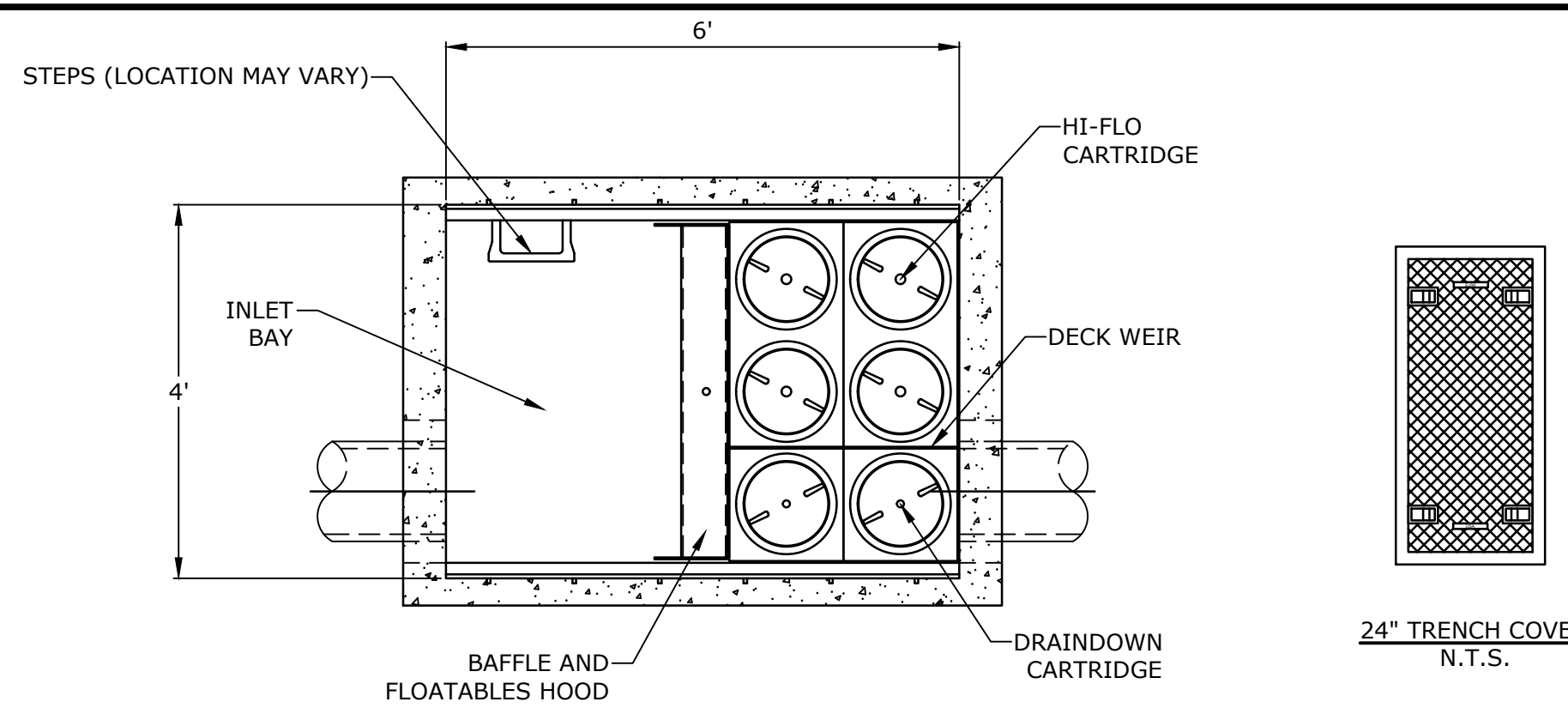

PLAN VIEW
(TOP SLAB SHOW FOR CLARITY)

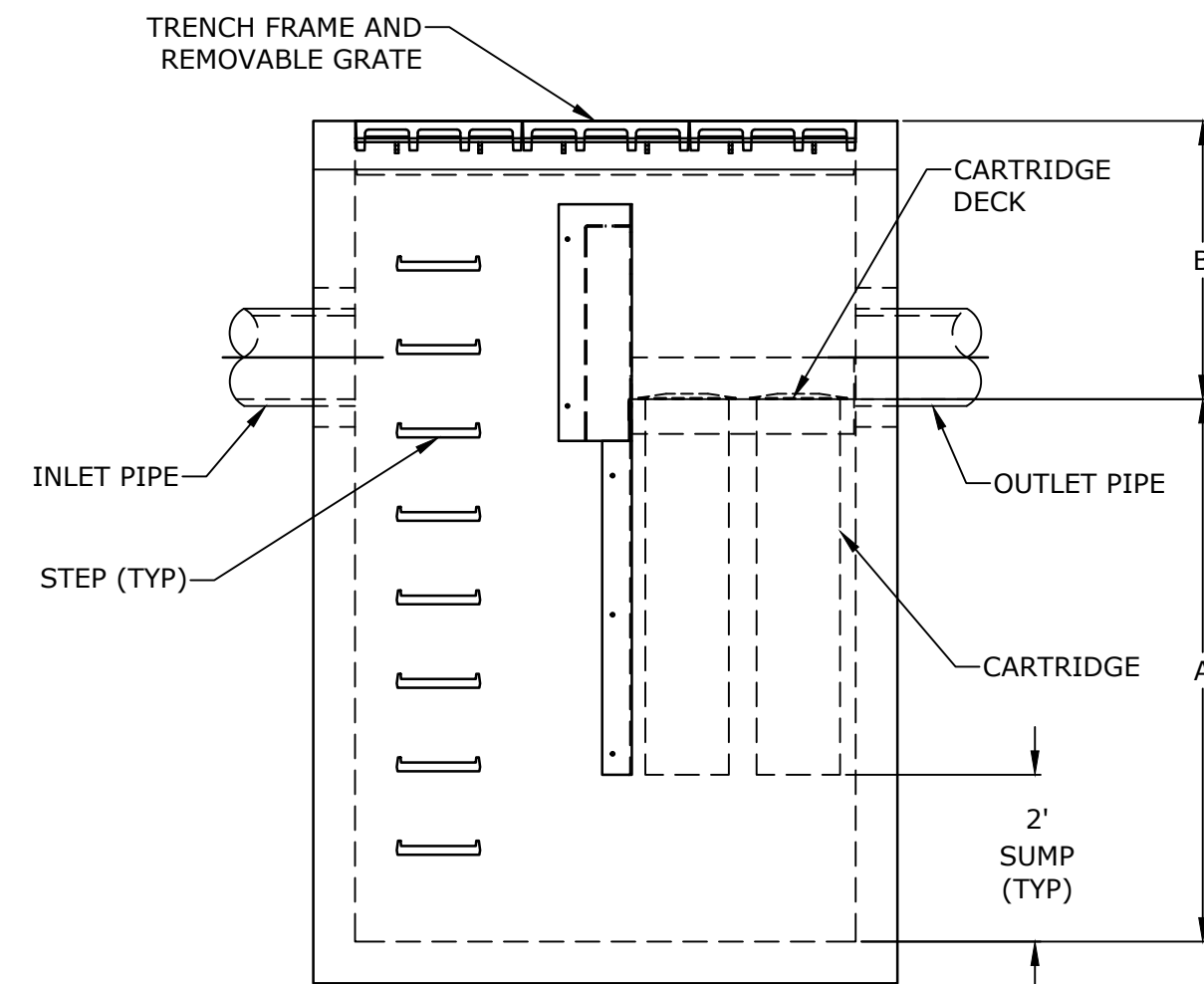

ELEVATION VIEW

JF0406 DETAIL
NO SCALE

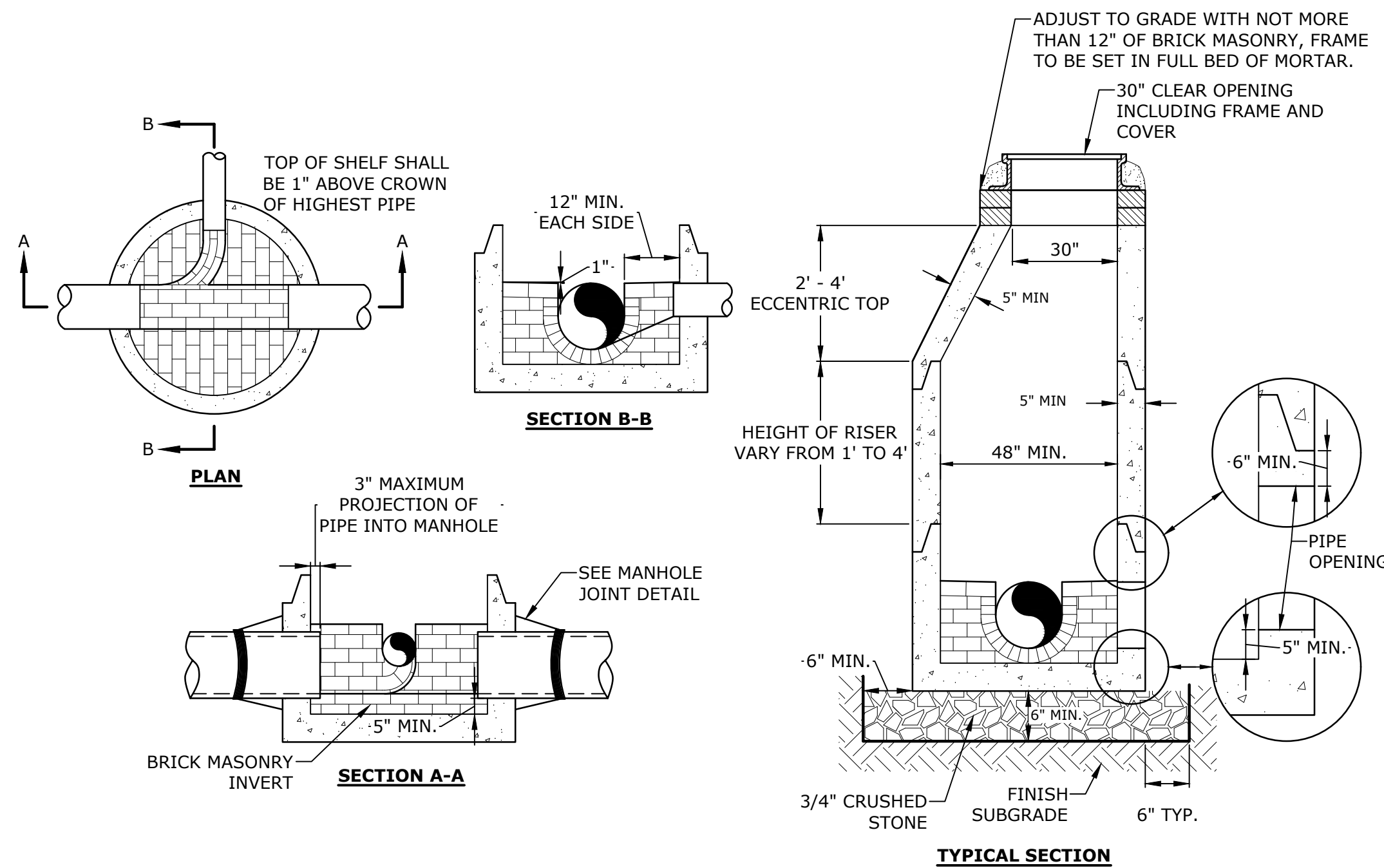

TYPICAL SECTION

- NOTES:**
- INVERT AND SHELF TO BE PLACED AFTER EACH LEAKAGE TEST.
 - CARE SHALL BE TAKEN TO INSURE THAT THE BRICK INVERT IS A SMOOTH CONTINUATION OF THE SEWER INVERT.
 - INVERT BRICKS SHALL BE LAID ON EDGE.
 - TWO (2) COATS OF BITUMINOUS WATERPROOF COATING SHALL BE APPLIED TO ENTIRE EXTERIOR OF MANHOLE.
 - FRAMES AND COVERS:** MANHOLE FRAMES AND COVERS WITHIN CITY RIGHT OF WAY SHALL BE CITY STANDARD HINGE COVERS MANUFACTURED BY EJ. FRAMES AND COVERS WILL BE PURCHASED FROM THE CITY OF PORTSMOUTH DEPARTMENT OF PUBLIC WORKS. ALL OTHER MANHOLE FRAMES AND COVERS SHALL BE OF HEAVY DUTY DESIGN AND PROVIDE A 30-INCH CLEAR OPENING. A 3-INCH (MINIMUM HEIGHT) WORD "SEWER" SHALL BE PLAINLY CAST INTO THE CENTER OF EACH COVER.
 - HORIZONTAL JOINTS SHALL BE SEALED FOR WATER TIGHTNESS USING A DOUBLE ROW OF ELASTOMERIC OR MASTIC-LIKE SEALANT.
 - BARREL AND CONE SECTIONS SHALL BE PRECAST REINFORCED CONCRETE DESIGNED FOR H20 LOADING, AND CONFORMING TO ASTM C478-06.

SEWER MANHOLE
NO SCALE

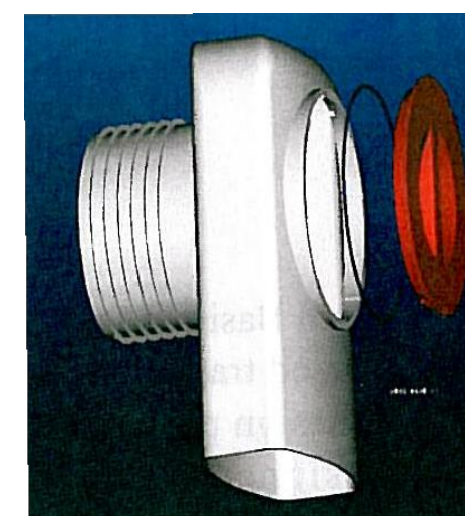

"ELIMINATOR" OIL FLOATING DEBRIS TRAP
NO SCALE

- NOTES:**
- ALL CATCH BASIN OUTLETS TO HAVE "ELIMINATOR" OIL AND FLOATING DEBRIS TRAP MANUFACTURED BY KLEANSTREAM (NO EQUAL).
 - INSTALL DEBRIS TRAP TIGHT TO INSIDE OF STRUCTURE.
 - 1/4" HOLE SHALL BE DRILLED IN TOP OF DEBRIS TRAP



SOUTH ELEVATION
SCALE: 1" = 10'-0"



WEST ELEVATION
SCALE: 1" = 10'-0"



NORTH ELEVATION
SCALE: 1" = 10'-0"



EAST ELEVATION
SCALE: 1" = 10'-0"



PROPOSED APARTMENT BUILDING - 815 LAFAYETTE ROAD
PORTSMOUTH, NEW HAMPSHIRE

BOA SUBMISSION

8/29/2023

mjk MICHAEL J. KEANE
ARCHITECTS, PLLC

101 KENT PLACE NEWMARKET, NH 03857 603.292.1400

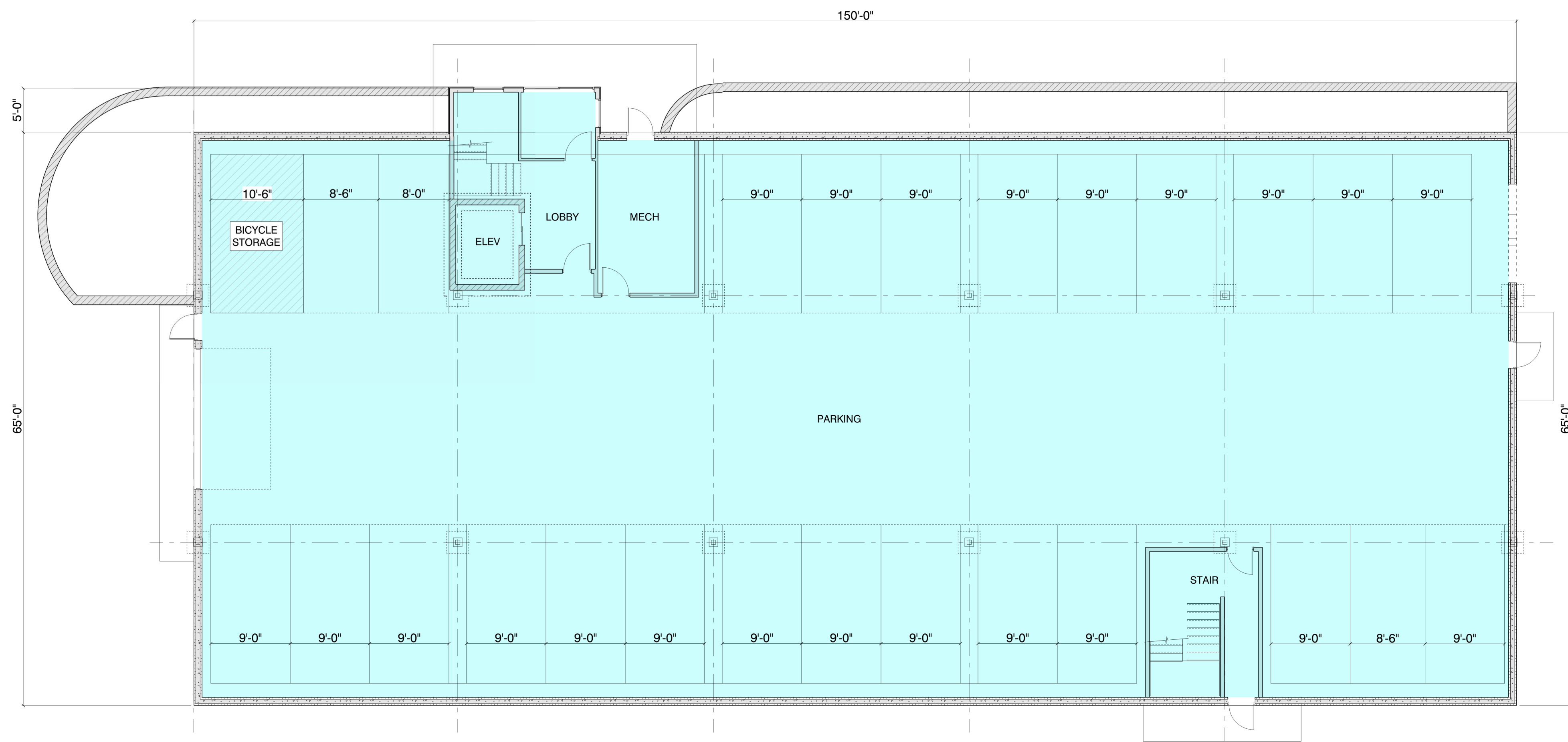

GARAGE LEVEL PLAN
SCALE: 1/8" = 1'-0"

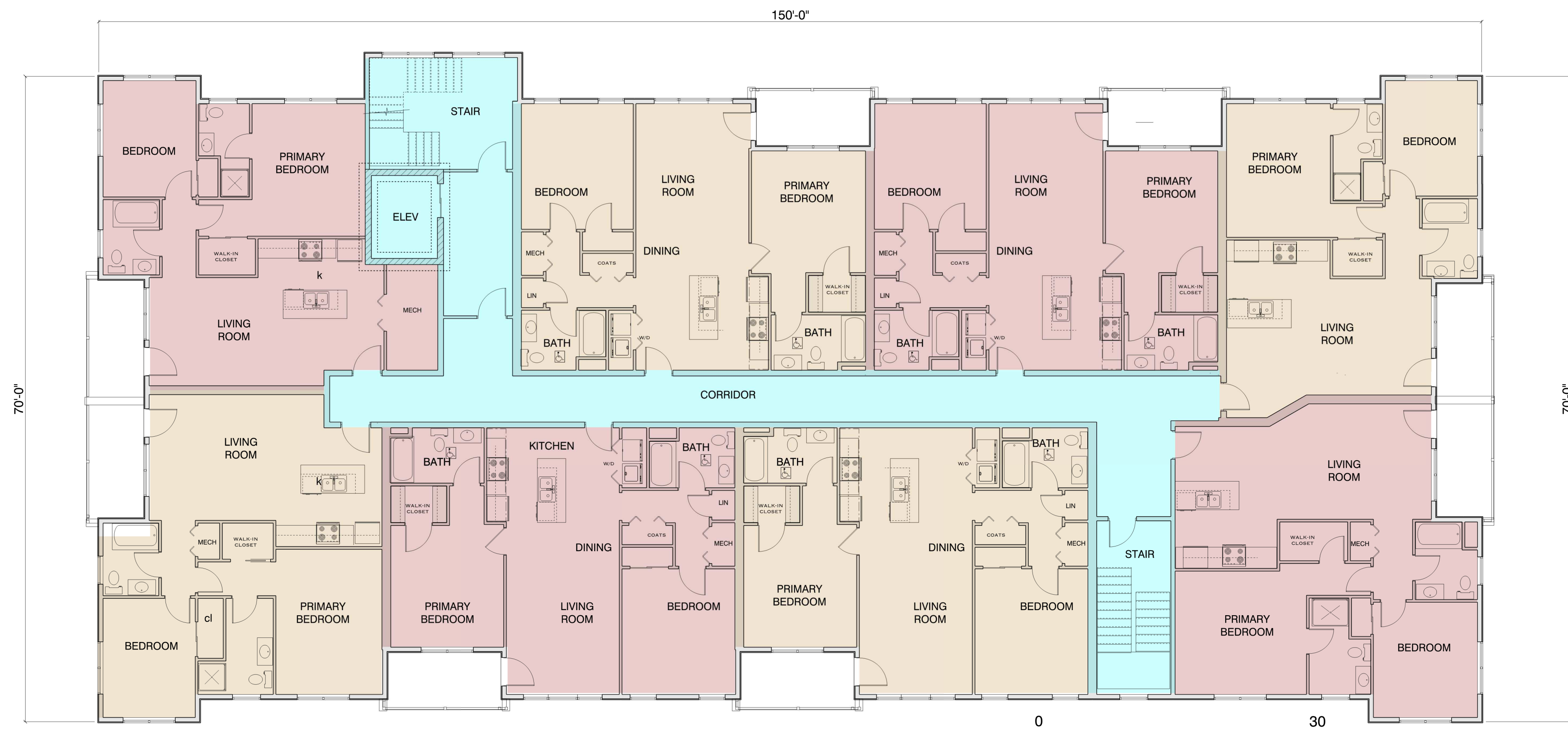

TYPICAL FLOOR PLAN 2-4
SCALE: 1/8" = 1'-0"

PROPOSED APARTMENT BUILDING - 815 LAFAYETTE ROAD
PORTSMOUTH, NEW HAMPSHIRE

BOA SUBMISSION

8/29/2023

mjk MICHAEL J. KEANE
ARCHITECTS, PLLC

101 KENT PLACE NEWMARKET, NH 03857 603.292.1400

2

PROPOSED MULTI-FAMILY DEVELOPMENT
815 LAFAYETTE RD
PORTSMOUTH, NEW HAMPSHIRE

WETLAND BUFFER IMPERVIOUS
SURFACE EXHIBIT



Local Wetland Buffer Setback	Impervious Surface	
	Existing Condition	Proposed Development
0 - 25 FT	218 SF	0 SF
25 - 50 FT	1,937 SF	1,536 SF
50 - 100 FT	9,583 SF	542 SF
Total Impervious Surface	11,738 SF	2,078 SF
Net Impervious Surface	-9,660 SF	

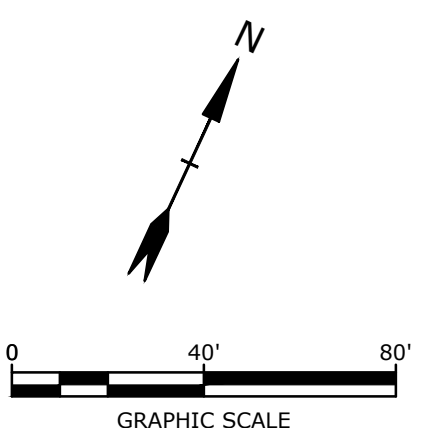
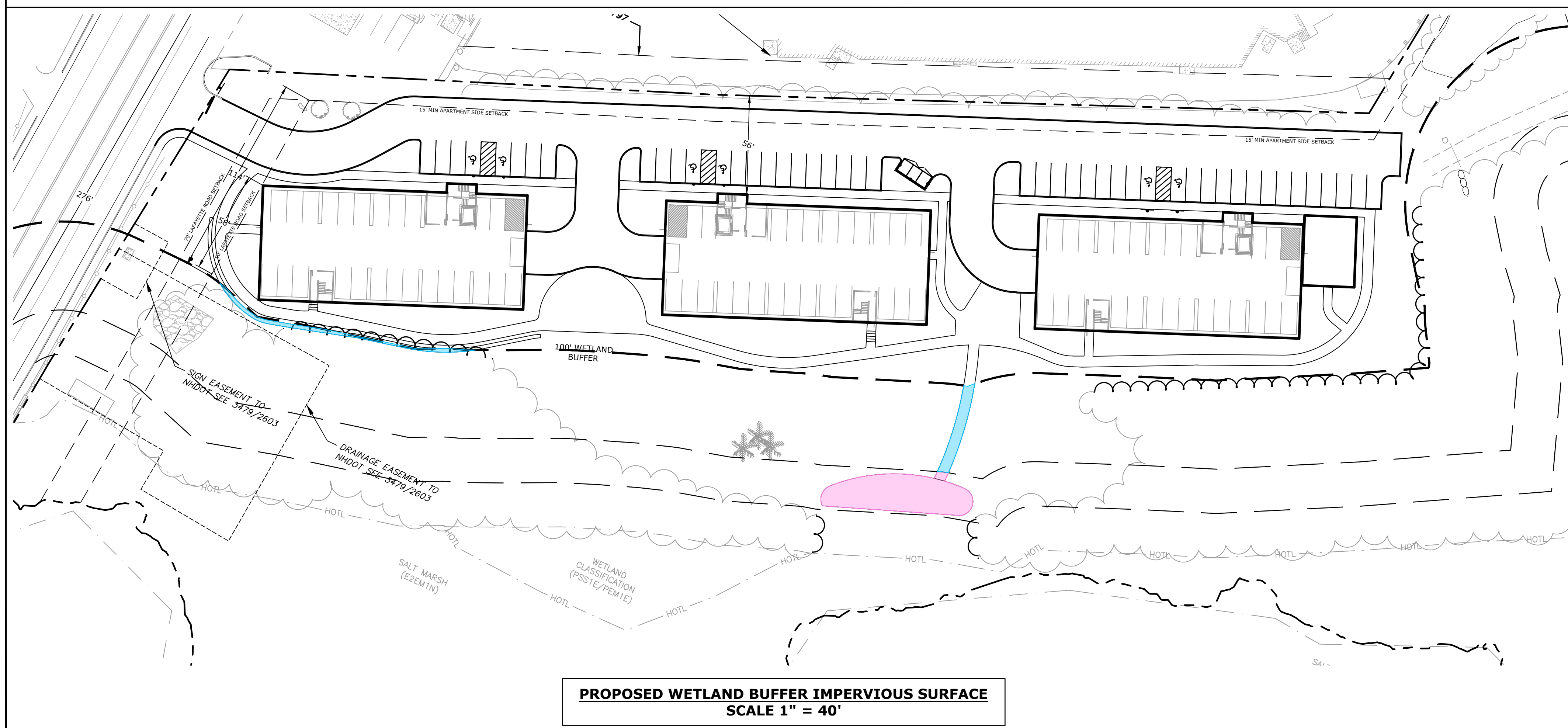



Tighe & Bond

Last Save Date: September 5, 2023 9:38 AM By: CKRZCUIK
 Plot Date: Tuesday, September 05, 2023 Plotted By: Collier Kzcuik
 TSS File Location: J:\M5131-001-DSGN.dwg

PROPOSED MULTI-FAMILY DEVELOPMENT
815 LAFAYETTE RD
PORTSMOUTH, NEW HAMPSHIRE

COMMUNITY SPACE EXHIBIT

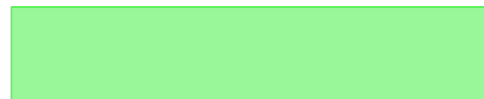
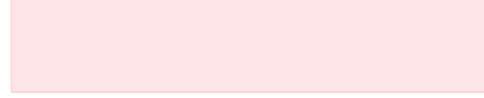

PROPOSED COMMUNITY SPACE:		REQUIRED	PROVIDED
	GREENWAY COMMUNITY SPACE		16,113 SF
	POCKET PARK COMMUNITY SPACE		2,523 SF
	PARK COMMUNITY SPACE		349,164 SF
	TOTAL DEVELOPMENT LOT	85,556 SF (10%)	855,562 SF
TOTAL COMMUNITY SPACE AREA		85,556 SF	367,800 SF

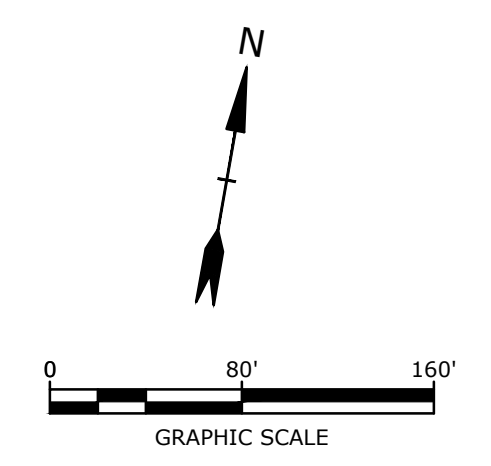

Last Save Date: September 5, 2023 9:38 AM By: CKRZCUIK
 Plot Date: Tuesday, September 05, 2023 Plotted By: Collier Kzcuik
 TSS File Location: J:\M5131-001-DSGN.dwg
 TSS File Location: J:\M5131-001-DSGN.dwg Layout Tab: COMM

Owner/Agent Letter of Authorization

This letter is to authorize Tighe & Bond, Inc. (Civil Engineer), to represent and submit on behalf of Prospect North 815, LLC (Owner/Applicant), applications and materials in all site design and permitting matters for the proposed development project located at 815 Lafayette Road in Portsmouth, New Hampshire on parcel of land identified as Map 245 Lot 3. This project includes the construction of multifamily buildings, an office building, and associated on-site improvements. This authorization shall relate to those activities that are required for local, state and federal permitting for the above project and include any required signatures for those applications.



Signature

Michael Brown

Print Name

6-1-23

Date



Witness

Jeffrey A. Philbrick

Print Name

6/1/23



Date

PROPOSED MULTI-FAMILY DEVELOPMENT
815 LAFAYETTE RD
PORTSMOUTH, NEW HAMPSHIRE

COMMUNITY SPACE EXHIBIT

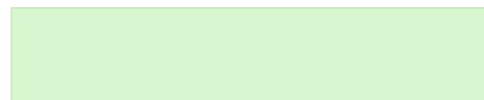

PROPOSED COMMUNITY SPACE:

	REQUIRED	PROVIDED
 GREENWAY COMMUNITY SPACE		86,720 SF
 TOTAL DEVELOPMENT LOT	85,556 SF (10%)	
	855,562 SF	
TOTAL COMMUNITY SPACE AREA	85,556 SF	86,720 SF (10.1%)

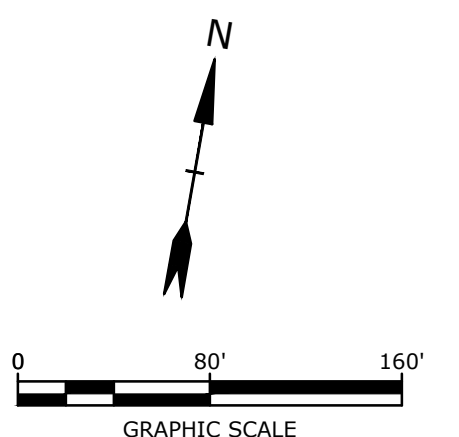



AERIAL OVERLAY EXHIBIT

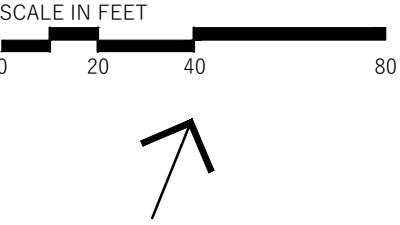



The State of New Hampshire
Department of Environmental Services



Robert R. Scott, Commissioner

September 13, 2023

PORTSMOUTH MUNICIPAL CLERK/CONSERVATION COMMISSION
1 JUNKINS AVE
PORTSMOUTH NH 03801



Re: Received Standard Dredge and Fill Wetlands Permit Application (RSA 482-A)
NHDES File Number: 2023-02503
Subject Property: Maplewood Ave, Portsmouth, Tax Map #123, Lot #ROW

Dear Sir or Madam:

On September 13, 2023, the New Hampshire Department of Environmental Services (NHDES) Wetlands Bureau received the above-referenced Standard Dredge and Fill Wetlands Permit Application (Application). On September 13, 2023, NHDES determined the Application was administratively complete in accordance with RSA 482-A:3, XIV. *Please note this letter is **not** a permit or authorization to begin work.*

Pursuant to RSA 482-A:11, III, if notification by a local conservation commission, local river management advisory committee, or the New Hampshire Rivers Council pursuant to this paragraph is not received by the department within 14 days (**September 25, 2023**) following the date the notice is filed with the municipal clerk, the department shall not suspend its normal action, but shall proceed as if no notification has been made. Please include the NHDES file number on the written notification.

Please provide a copy of this letter to all local level departments, boards, and commissions. Pursuant to current state laws and regulations, NHDES is not authorized to consider local zoning and regulatory issues pertaining to a project. These issues must be addressed at the local level.

If you have any questions, please contact the Wetlands Bureau at (603) 271-2147.

Sincerely,

Brandy Holmes
Application Receipt Center, Wetlands Bureau
Land Resources Management, Water Division

www.des.nh.gov

29 Hazen Drive • PO Box 95 • Concord, NH 03302-0095
NHDES Main Line: (603) 271-3503 • Subsurface Fax: (603) 271-6683 • Wetlands Fax: (603) 271-6588
TDD Access: Relay NH 1 (800) 735-2964



The State of New Hampshire
Department of Environmental Services



Robert R. Scott, Commissioner

September 06, 2023

PEASE DEVELOPMENT AUTHORITY
NH DIVISION OF PORTS AND HARBOR
C/O GENO MARCONI
555 MARKET ST
PORTSMOUTH NH 03801



Re: Approved Standard Dredge and Fill Wetlands Permit Application (RSA 482-A)
NHDES File Number: 2022-00429
Subject Property: Market Street Marine Terminal, Portsmouth, Tax Map #119, Lot #5

Dear Owner:

On September 06, 2023, the New Hampshire Department of Environmental Services (NHDES) Wetlands Bureau approved the above-referenced application to Impact 130,520 square feet within the bed, banks, and tidal buffer zone of the Piscataqua River to complete the following activities in order to provide for safe docking and freight discharge of cargo vessels at Division of Ports and Harbors Port facility:

1. Relocate an existing floating dock to the west.
2. Dredge approximately 16,000 cubic yards of material from 61,450 square feet of tidal riverbed.
3. Extend the Main Wharf 145 feet to the northwest.
4. Extend the Main Wharf 60 feet to the southeast and then 120 feet to the southwest to tie into the shore.
5. Install 600 square feet of riprap where the extended wharf meets the shore.
6. Add a new fender system to the Main Wharf.
7. Regrade, pave, and install drainage improvements within 46,840 square feet of developed upland tidal buffer zone.

Compensatory mitigation shall consist of a one-time payment of \$1,004,210.24 into the Aquatic Resource Mitigation (ARM) Fund for the permanent impacts to the bed and banks of the Piscataqua River to be deposited within the Salmon Falls - Piscataqua Rivers Watershed account.

In accordance with RSA 482-A:10, RSA 21-O:14, and Rules Env-WtC 100-200, **any person aggrieved by this decision may file a Notice of Appeal directly with the NH Wetlands Council (Council) within 30 days of the decision date, September 06, 2023.** Every ground claiming the decision is unlawful or unreasonable must be fully set forth in the Notice of Appeal. Only the grounds set forth in the Notice of Appeal are considered by the Council. Information about the Council, including Council Rules, is available at <https://www.nhec.nh.gov/wetlands-council/about>. For appeal related issues, contact the Council Appeals Clerk at (603) 271-6072.

In accordance with RSA 482-A:3, II(a) and Env-Wt 313.02(b), as your project is a major project located in a great pond or in public waters of the state, your application must also be approved by the Governor and the Executive Council. Upon expiration of the appeal period, a redacted copy of the file is submitted to the Governor and the Executive Council for their consideration. Information about the Governor and the Executive Council is available at <https://www.nh.gov/council/>.

www.des.nh.gov

29 Hazen Drive • PO Box 95 • Concord, NH 03302-0095
NHDES Main Line: (603) 271-3503 • Subsurface Fax: (603) 271-6683 • Wetlands Fax: (603) 271-6588
TDD Access: Relay NH 1 (800) 735-2964

Sincerely,



Philip Trowbridge, P.E., Manager
Land Resources Management, Water Division

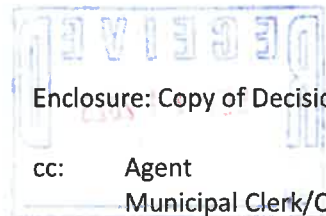

Enclosure: Copy of Decision

cc: Agent
Municipal Clerk/Conservation Commission
Abutters
ec: Assistant Administrator, Wetlands Bureau

DECISION DATE:
September 06, 2023

DECISION:

Impact 130,520 square feet within the bed, banks, and tidal buffer zone of the Piscataqua River to complete the following activities in order to provide for safe docking and freight discharge of cargo vessels at Division of Ports and Harbors Port facility:

1. Relocate an existing floating dock to the west.
2. Dredge approximately 16,000 cubic yards of material from 61,450 square feet of tidal riverbed.
3. Extend the Main Wharf 145 feet to the northwest.
4. Extend the Main Wharf 60 feet to the southeast and then 120 feet to the southwest to tie into the shore.
5. Install 600 square feet of riprap where the extended wharf meets the shore.
6. Add a new fender system to the Main Wharf.
7. Regrade, pave, and install drainage improvements within 46,840 square feet of developed upland tidal buffer zone.

Compensatory mitigation shall consist of a one-time payment of \$1,004,210.24 into the Aquatic Resource Mitigation (ARM) Fund for the permanent impacts to the bed and banks of the Piscataqua River to be deposited within the Salmon Falls - Piscataqua Rivers Watershed account.

CONDITIONS:

1. All work shall be completed in accordance with plans titled "Market Street Marine Terminal Functional Replacement Barge Dock Environmental Impact Plans" by Appledore Marine Engineering, LLC dated July 2023, as received by the NH Department of Environmental Services (NHDES) on July 13, 2023.
2. This permit is not valid and effective until the permittee records this permit at the Rockingham County Registry of Deeds as required by RSA 482-A:3, VI. Any limitations or conditions in the permit so recorded shall run with the land beyond the expiration of the permit. Prior to starting work under this permit, the permittee shall submit a copy of the recorded permit stamped by the registry with the book and page and date of receipt to the NHDES Wetlands Program by certified mail, return receipt requested.
3. This approval is contingent upon the receipt of a one-time in lieu fee payment not to exceed \$1,004,210.24 to the NHDES Aquatic Resource Mitigation (ARM) Fund. The applicant shall remit payment payable to "Treasurer- State of NH" and mailed to NHDES Wetlands Bureau, 29 Hazen Drive, PO Box 95, Concord, NH 03302-0095. NHDES shall not release the permit until such time as the full amount of the in-lieu fee payment is received.
4. The permittee shall implement the Turbidity Control and Monitoring Plan received by NHDES on April 17, 2023, and approved and conditioned by the NHDES Watershed Management Bureau Water Quality Planning Section on August 10, 2023.
5. Not less than five (5) state business days prior to starting work authorized by this permit, the permittee shall notify the NHDES Wetlands Program and the local conservation commission in writing of the date on which work under this permit is expected to start.
6. All in water activities including but not limited to blasting, dredging, and pile installation, with the exception of pile installation that complies with Conditions #7 - #9 below, shall occur between November 15 and March 15 to protect anadromous fish as required to maintain compliance with RSA 212-A.
7. Per recommendations of the NH Fish and Game Department (NHF&G) to protect anadromous fish, a safe unimpacted zone of passage of approximately 1,000 feet in width shall be maintained throughout the duration of the project for any sensitive species that may be foraging or migrating in the river during construction as required to maintain compliance with RSA 212-A.

8. Per recommendations of the NH Fish and Game Department (NHF&G) to protect anadromous fish, directly prior to installing the piles, the contractor shall create a deterrent noise that will initiate a startle response for any anadromous fish species that may be in the immediate vicinity. This can be accomplished by loudly banging on the piles and waiting 5 to 10 minutes to allow sufficient time for any fish to vacate the location of the sound to avoid any further conflict with construction equipment as required to maintain compliance with RSA 212-A.
9. Per recommendations of the NH Fish and Game Department (NHF&G) to protect anadromous fish, where applicable piles will be installed using a vibratory hammer as much as possible and then impact driven using a cushion block as required to maintain compliance with RSA 212-A.
10. Work shall be carried out in a time and manner to avoid disturbances to migratory waterfowl breeding and nesting areas as required to maintain compliance with Env-Wt 304.06.
11. Work authorized shall be carried out such that there are no discharges in or to spawning or nursery areas during spawning seasons. Impacts to such areas shall be avoided or minimized to the maximum extent practicable during all other times of the year as required to maintain compliance with Env-Wt 304.06.
12. No person undertaking any activity shall cause or contribute to, or allow the activity to cause or contribute to, any violations of the surface water quality standards in RSA 485-A and Env-Wq 1700 as required to maintain compliance with Env-Wt 304.06.
13. Work shall be conducted in a manner so as to minimize turbidity and sedimentation to surface waters and wetlands as required to maintain compliance with Env-Wt 304.06.
14. Appropriate siltation and erosion controls shall be in place prior to construction, shall be maintained during construction, and shall remain until the area is stabilized. Temporary controls shall be removed once the area has been stabilized as required to maintain compliance with Env-Wt 304.06.
15. Erosion, siltation, and turbidity control products shall be installed per manufacturers recommended specifications as required to maintain compliance with Env-Wt 304.06.
16. A certified wetlands scientist or qualified professional, as applicable, shall monitor the project during construction to verify that all work is done in accordance with the approved plans and narratives, adequate siltation and erosion controls are properly implemented, and no water quality violations occur as required to maintain compliance with Env-Wt 304.06. Weekly construction monitoring reports shall be provided to NHDES through the duration of the project and a follow-up report including photographs of all stages of construction shall be submitted to the NHDES Wetlands Program within 60 days of final site stabilization.
17. Dredging shall not disturb contaminated layers of sediment. If the permittee/permittee's contractor suspects that contaminated sediment has been disturbed, they shall cease operation and contact the NHDES Hazardous Waste Remediation Bureau immediately.
18. No dredged or excavated material removed from the bed of the Piscataqua River to construct the proposed navigation channel shall be disposed of at an approved offshore disposal site until the appropriate Federal approval has been obtained.
19. Excavated material and construction-related debris within the tidal buffer zone shall be placed outside of the areas subject to RSA 482-A. Any material deposited within 250 feet of any surface water shall comply with RSA 483-B.
20. Construction of the wharf shall occur from land, or from a barge and crane if land-based construction is not feasible, to reduce potential impacts to the intertidal zone.
21. Any fill used shall be clean sand, gravel, rock, or other suitable material.
22. No concrete is to be used anywhere in the construction of the stone riprap revetment. All stone shall be dry laid or placed stone underlain with filter fabric.
23. Any stone used in the construction or repair of a revetment shall be of suitable size and weight to assure that the structure is stable and will withstand ocean storm wave energy anticipated at this location.
24. The permittee shall monitor the area surrounding the permitted structure for the occurrence of special aquatic sites (SAS) or submerged aquatic vegetation (SAV) such as Eelgrass (*Zostera marina*) and assure that continued use of the permitted structure will not adversely impact aquatic resources.

FINDINGS:

1. This project has been reviewed for compliance with the NH Wetlands Bureau Administrative Rules as in effect prior to December 15, 2019, in accordance with the Memorandum of Agreement (MoA) between the Department of Environmental Services and the Department of Transportation Regarding Wetlands Rules Applicability for Projects Initiated Prior to December 15, 2019, as executed on October 15, 2020.
2. This project is classified as a Major Project per NH Administrative Rule Env-Wt 303.02(a), projects located tidal wetlands, except for repair of existing structures, Rule Env-Wt 303.02(d), construction or modification of major docking system defined by Env-Wt 101.56, and any dock adjacent or attached to a breakwater, and Rule Env-Wt 303.02(g), removal of more than 20 cubic yards of rock, gravel, sand, mud, or other material from public waters.
3. On February 24, 2022, the Department received correspondence from the NH Fish and Game Department (NHF&G) dated June 13, 2019, stating that the NHF&G Nongame and Endangered Wildlife Program did not expect impacts to non-aquatic protected wildlife species as a result of the proposed work.
4. On April 17, 2023, the Department received correspondence from the NH Fish and Game Department (NHF&G) dated February 8, 2023, and December 20, 2022, stating that the NHF&G had "no new comments and will not require further consultation prior to submitting permit applications" and included a list of four avoidance and minimization measures to be followed during pile driving activities to minimize impacts to anadromous fish species. NHF&G recommendations have been included as conditions in the permit.
5. NHDES finds that the project as approved and conditioned will not have an unreasonable adverse impact on the value of such areas as sources of nutrients for finfish, crustacea, shellfish and wildlife of significant value, nor will it damage or destroy habitats and reproduction areas for plants, fish and wildlife of importance.
6. On April 4, 2022, NHDES received comments from the Portsmouth Conservation Commission dated March 24, 2022, stating that the commission recommend approval of the project provided the applicant "fulfill[s] the recommendations of the National Marine Fisheries Service."
7. On February 9, 2023, the applicant obtained a statement from the Pease Development Authority, Division of Ports and Harbors regarding the projects impact on navigation and passage stating, "[w]e examined the proposed site and found that the structure will have no negative effect on navigation in the channel," per Rule Env-Wt 302.04(a)(8).
8. Pursuant to Env-Wt 302.03(b), compensatory mitigation is required as the project impacts tidal wetlands that are intended to remain when the proposed project is completed.
9. NHDES has determined that an in-lieu mitigation payment of \$1,004,210.24 pursuant to Per Rule Env-Wt 803.10(e), to be deposited in the ARM fund for the Salmon Falls - Piscataqua Rivers watershed per RSA 482-A:29 as mitigation to offset the impacts associated with the approved permanent impacts to the bed and bank tidal waters.
10. On April 17, 2023, NHDES received a request to waive Rule Env-Wt 402.21, to relieve the applicant from the requirement to demonstrate that the modification of the existing docking structure is less environmentally-impacting or provides for fewer boat slips and less construction surface area over public submerged lands than the current configuration to modify the existing docking structures.
11. On April 17, 2023, NHDES received a request to waive Rule Env-Wt 606.03(c), to relieve the applicant from design criteria requiring that superstructures shall not completely shield the underlying area from direct sunlight.
12. The department finds that the documentation provided by the applicant provides clear and convincing evidence that granting the waivers will not result in either an avoidable adverse impact on the environment or natural resources of the state; an avoidable adverse impact on public health or public safety; nor any impact on abutting properties that is more significant than that which would result from complying with the rule; or a statutory requirement being waived; and any benefit to the public or the environment from complying with the rule is outweighed by the operational or economic costs to the applicant, and thus, that the requirements of Env-Wt 204.05 have been met.



The State of New Hampshire
Department of Environmental Services



Robert R. Scott, Commissioner

WETLANDS AND NON-SITE SPECIFIC PERMIT 2022-02721

NOTE CONDITIONS

PERMITTEE: KATARA LLC
274 MILLER AVE
PORTSMOUTH NH 03801

PROJECT LOCATION: 70 PLEASANT POINT DR, PORTSMOUTH
TAX MAP #207, LOT #15

WATERBODY: PISCATAQUA RIVER

APPROVAL DATE: JULY 03, 2023

EXPIRATION DATE: JULY 03, 2028

Based upon review of permit application 2022-02721 in accordance with RSA 482-A and RSA 485-A:17, the New Hampshire Department of Environmental Services (NHDES) hereby issues this Wetlands and Non-Site Specific Permit. To validate this Permit, signatures of the Permittee and the Principal Contractor are required.

PERMIT DESCRIPTION:

Impact 96 square feet (SF) of previously developed upland tidal buffer zone and 906 SF of tidal wetland to construct a tidal docking structure consisting of a 5 foot by 6 foot access stairs connected to a 6 foot by 72 foot fixed pier connected to a 4 foot by 30 foot ramp connected to a 10 foot by 40 foot float with associated piles and float stops. The overall length of this docking structure, seaward of the highest observable tide line, is 101 feet, on approximately 360 feet of frontage along the Piscataqua River in Portsmouth.

THIS PERMIT IS SUBJECT TO THE FOLLOWING PROJECT-SPECIFIC CONDITIONS:

1. All work shall be done in accordance with the approved plans dated June 27, 2022, and revised through March 6, 2023, by TF Moran, Inc., and last received by the NH Department of Environmental Services (NHDES) on April 4, 2023, in accordance with Env-Wt 307.16
2. This permit shall not be effective until the permittee records this permit at the Rockingham County Registry of Deeds. Any limitations or conditions in the permit so recorded shall run with the land beyond the expiration of the permit. The permittee shall provide the NHDES with a copy of the permit stamped by the registry with the book and page and date of receipt, in accordance with New Hampshire Administrative Rule Env-Wt 314.02(b) and (c).
3. Pile installation shall occur between November 15 and March 15, to protect anadromous fish as required by Env-Wt 307.06.
4. The ramp and float portions of residential tidal docks shall be seasonal and removed from the water during the non-boating season, in accordance with Env-Wt 606.06(b).
5. Tidal docking installation shall be done by barge or upland to prevent the driving of construction equipment in or through tidal waters/wetlands or on the bottom of the inter-tidal zone, in accordance with Env-Wt 606.05(b).
6. Tidal docking construction shall be done in accordance with the standard conditions in Env-Wt 307.
7. Heavy equipment shall not be operated in any jurisdictional area unless specifically authorized by this permit, in accordance with Env-Wt 307.15(a).
8. In accordance with Env-Wt 307.03(h), equipment shall be staged and refueled outside of jurisdictional areas and in accordance with Env-Wt 307.15.

www.des.nh.gov

29 Hazen Drive • PO Box 95 • Concord, NH 03302-0095

NHDES Main Line: (603) 271-3503 • Subsurface Fax: (603) 271-6683 • Wetlands Fax: (603) 271-6588

TDD Access: Relay NH 1 (800) 735-2964

9. In accordance with Env-Wt 307.03(g)(2), the person in charge of construction equipment shall repair any leaks prior to using the equipment in an area where such fluids could reach groundwater, surface waters, or wetlands.
10. In accordance with Env-Wt 307.03(g)(3) and (4), the person in charge of construction equipment shall maintain oil spill kits and diesel fuel spill kits, as applicable to the type(s) and amount(s) of oil and diesel fuel used, on site so as to be readily accessible at all times during construction; and train each equipment operator in the use of the spill kits.

THIS PERMIT IS SUBJECT TO THE FOLLOWING GENERAL CONDITIONS:

1. Pursuant to RSA 482-A:12, a copy of this permit shall be posted in a secure manner in a prominent place at the site of the approved project.
2. In accordance with Env-Wt 313.01(a)(5), and as required by RSA 482-A:11, II, work shall not infringe on the property rights or unreasonably affect the value or enjoyment of property of abutting owners.
3. In accordance with Env-Wt 314.01, a standard permit shall be signed by the permittee, and the principal contractor who will build or install the project prior to start of construction, and will not be valid until signed.
4. In accordance with Env-Wt 314.03(a), the permittee shall notify the department in writing at least one week prior to commencing any work under this permit.
5. In accordance with Env-Wt 314.08(a), the permittee shall file a completed notice of completion of work and certificate of compliance with the department within 10 working days of completing the work authorized by this permit.
6. In accordance with Env-Wt 314.06, transfer of this permit to a new owner shall require notification to, and approval of, the NHDES.
7. The permit holder shall ensure that work is done in a way that protects water quality per Env-Wt 307.03; protects fisheries and breeding areas per Env-Wt 307.04; protects against invasive species per Env-Wt 307.05; meets dredging activity conditions in Env-Wt 307.10; and meets filling activity conditions in Env-Wt 307.11.
8. This project has been screened for potential impact to known occurrences of protected species and exemplary natural communities in the immediate area. Since many areas have never been surveyed, or only cursory surveys have been performed, unidentified sensitive species or communities may be present. This permit does not absolve the permittee from due diligence in regard to state, local or federal laws regarding such communities or species. This permit does not authorize in any way the take of threatened or endangered species, as defined by RSA 212-A:2, or of any protected species or exemplary natural communities, as defined in RSA 217-A:3.
9. In accordance with Env-Wt 307.06(a) through (c), no activity shall jeopardize the continued existence of a threatened or endangered species, a species proposed for listing as threatened or endangered, or a designated or proposed critical habitat under the Federal Endangered Species Act, 16 U.S.C. §1531 et seq.; State Endangered Species Conservation Act, RSA 212-A; or New Hampshire Native Plant Protection Act, RSA 217-A.
10. In accordance with Env-Wt 307.02, and in accordance with federal requirements, all work in areas under the jurisdiction of the U.S. Army Corps of Engineers (USACE) shall comply with all conditions of the applicable state general permit.

APPROVED:



Kristin L. Duclos
Wetlands Specialist, Wetlands Bureau
Land Resources Management, Water Division

THE SIGNATURES BELOW ARE REQUIRED TO VALIDATE THIS PERMIT (Env-Wt 314.01).

PERMITTEE SIGNATURE (required)

PRINCIPAL CONTRACTOR SIGNATURE (required)

**NEW HAMPSHIRE
DEPARTMENT OF STATE**



I, *David M. Scanton*, Secretary Of State, of the State of New Hampshire, do hereby certify that the Governor and Executive Council, at their meeting on August approved ITEM #131 authorized Katara LLC's request to perform work on Piscataqua River in Portsmouth, NH.



In Testimony Whereof, I have set my hand and cause to be affixed the Seal of the State of New Hampshire, this twenty-third day of August, in the year of Our Lord, two thousand and twenty-three.

A handwritten signature in black ink, appearing to read "D. Scanton".

Secretary of State



The State of New Hampshire
Department of Environmental Services



Robert R. Scott, Commissioner

WETLANDS AND NON-SITE SPECIFIC PERMIT 2023-00232

NOTE CONDITIONS

PERMITTEE: 227 MARKET STREET LLC
JAQUELINE MAHONEY
27 AUSTIN ST
PORTSMOUTH NH 03801

NH STATE PORT AUTHORITY
C/O GENO MARCONI
555 MARKET ST
PORTSMOUTH NH 03801

PROJECT LOCATION: 227 & 555 MARKET ST, PORTSMOUTH
TAX MAP #119, LOT #5 & 6

WATERBODY: PISCATAQUA RIVER

APPROVAL DATE: JUNE 14, 2023

EXPIRATION DATE: JUNE 14, 2028

Based upon review of permit application 2023-00232 in accordance with RSA 482-A and RSA 485-A:17, the New Hampshire Department of Environmental Services (NHDES) hereby issues this Wetlands and Non-Site Specific Permit. To validate this Permit, signatures of the Permittee and the Principal Contractor are required.

PERMIT DESCRIPTION:

Impact 1,201 square feet (SF) within the previously developed upland tidal buffer zone to install two replacement bollard moorings and impact 2,428 SF within the previously developed upland tidal buffer zone for site regrading. Temporarily impact 2,206 SF within the previously developed upland tidal buffer to install a subsurface stormwater treatment system, construction access, and erosion and sedimentation controls. Dredge and fill 26 SF within the bank and channel of the Piscataqua River to construct the discharge outfall for the stormwater treatment system and temporarily impact 25 SF within the bank and channel of the Piscataqua River for construction access and erosion and sedimentation controls.

Compensatory mitigation for 26 SF of permanent impacts to tidal waters consists of a one-time payment of \$334.61 into the Aquatic Resource Mitigation (ARM) Fund, within the Salmon Falls - Piscataqua Rivers Watershed account.

THIS PERMIT IS SUBJECT TO THE FOLLOWING PROJECT-SPECIFIC CONDITIONS:

1. All work shall be done in accordance with the approved plans dated December 29, 2022, and revised through May 5, 2023, by Tighe & Bond, Inc., and received by the NH Department of Environmental Services (NHDES) on May 10, 2023, in accordance with Env-Wt 307.16.
2. In accordance with Env-Wt 314.02(b) and (c), for projects in the coastal area, the permittee shall record any permit issued for shoreline stabilization and any work in the tidal buffer zone and tidal wetlands at the Rockingham County Registry of Deeds. Any limitations or conditions in the permit so recorded shall run with the land beyond the expiration of the permit. The permittee shall provide the department with a copy of the permit stamped by the registry with the book and page and date of receipt.

www.des.nh.gov

29 Hazen Drive • PO Box 95 • Concord, NH 03302-0095
NHDES Main Line: (603) 271-3503 • Subsurface Fax: (603) 271-6683 • Wetlands Fax: (603) 271-6588
TDD Access: Relay NH 1 (800) 735-2964

3. Permit issuance is contingent on submittal of a check in the amount of \$334.61 to the Aquatic Resource Mitigation Fund by the applicant as calculated per Env-Wt 803.07 and RSA 482-A:30.
4. In accordance with Env-Wt 807.01(b), the payment shall be received by NHDES within 120 days from the approval decision or NHDES will deny the application.
5. All development activities associated with any project shall be conducted in compliance with applicable requirements of RSA 483-B and Env-Wq 1400 during and after construction in accordance with Env-Wt 307.07.
6. All work associated with the construction of the stormwater outfall shall be done at low tide when the work area is fully exposed in accordance with Env-Wt 609.10(b)(4).
7. No activity shall be conducted in such a way as to cause or contribute to any violation of surface water quality standards per Env-Wt 307.03(a).
8. All work including management of soil stockpiles, shall be conducted so as to minimize erosion, minimize sediment transfer to surface waters or wetlands, and minimize turbidity in surface waters and wetlands per Env-Wt 307.03(b).
9. In accordance with Env-Wt 307.03(c)(3), water quality control measures shall be installed prior to start of work and in accordance with the manufacturer's recommended specifications or, if none, the applicable requirements of Env-Wq 1506 or Env-Wq 1508.
10. In accordance with Env-Wt 307.03(c)(1), water quality control measures shall be selected and implemented based on the size and nature of the project and the physical characteristics of the site, including slope, soil type, vegetative cover, and proximity to jurisdictional areas.
11. In accordance with Env-Wt 307.03(c)(5), water quality control measures shall be maintained so as to ensure continued effectiveness in minimizing erosion and retaining sediment on-site during and after construction.
12. In accordance with Env-Wt 307.03(c)(6), water quality control measures shall remain in place until all disturbed surfaces are stabilized to a condition in which soils on the site will not experience accelerated or unnatural erosion by achieving and maintaining a minimum of 85% vegetative cover using an erosion control seed mix, whether applied in a blanket or otherwise, that is certified by its manufacturer as not containing any invasive species; or placing and maintaining a minimum of 3 inches of non-erosive material such as stone.
13. In accordance with Env-Wt 307.03(c)(7), temporary water quality control methods shall be removed upon completion of work when compliance with Env-Wt 307.03(c)(6) is achieved.
14. Heavy equipment shall not be operated in any jurisdictional area unless specifically authorized by this permit, in accordance with Env-Wt 307.15(a).
15. In accordance with Env-Wt 307.03(h), equipment shall be staged and refueled outside of jurisdictional areas and in accordance with Env-Wt 307.15.
16. In accordance with Env-Wt 307.03(g)(1), the person in charge of construction equipment shall inspect such equipment for leaking fuel, oil, and hydraulic fluid each day prior to entering surface waters or wetlands or operating in an area where such fluids could reach groundwater, surface waters, or wetlands.
17. In accordance with Env-Wt 307.03(g)(2), the person in charge of construction equipment shall repair any leaks prior to using the equipment in an area where such fluids could reach groundwater, surface waters, or wetlands.
18. In accordance with Env-Wt 307.03(g)(3) and (4), the person in charge of construction equipment shall maintain oil spill kits and diesel fuel spill kits, as applicable to the type(s) and amount(s) of oil and diesel fuel used, on site so as to be readily accessible at all times during construction; and train each equipment operator in the use of the spill kits.
19. In accordance with Env-Wt 307.11(b), limits of fill shall be clearly identified prior to commencement of work and controlled in accordance with Env-Wt 307.03 to ensure that fill does not spill over or erode into any area where filling is not authorized.

20. In accordance with Env-Wt 307.11(a), fill shall be clean sand, gravel, rock, or other material that meets the project's specifications for its use; and does not contain any material that could contaminate surface or groundwater or otherwise adversely affect the ecosystem in which it is used.
21. In accordance with Env-Wt 307.12(i), wetland areas where permanent impacts are not authorized shall be restored to their pre-impact conditions and elevation by replacing the removed soil and vegetation in their pre-construction location and elevation such that post-construction soil layering and vegetation schemes are as close as practicable to pre-construction conditions.
22. In accordance with Env-Wt 307.03(e), all exposed soils and other fills shall be permanently stabilized within 3 days following final grading.
23. In accordance with Env-Wt 307.11(c), slopes shall be immediately stabilized by a method specified in Env-Wq 1506 or Env-Wq 1508, as applicable, to prevent erosion into adjacent wetlands or surface waters.

THIS PERMIT IS SUBJECT TO THE FOLLOWING GENERAL CONDITIONS:

1. Pursuant to RSA 482-A:12, a copy of this permit shall be posted in a secure manner in a prominent place at the site of the approved project.
2. In accordance with Env-Wt 313.01(a)(5), and as required by RSA 482-A:11, II, work shall not infringe on the property rights or unreasonably affect the value or enjoyment of property of abutting owners.
3. In accordance with Env-Wt 314.01, a standard permit shall be signed by the permittee, and the principal contractor who will build or install the project prior to start of construction, and will not be valid until signed.
4. In accordance with Env-Wt 314.03(a), the permittee shall notify the department in writing at least one week prior to commencing any work under this permit.
5. In accordance with Env-Wt 314.08(a), the permittee shall file a completed notice of completion of work and certificate of compliance with the department within 10 working days of completing the work authorized by this permit.
6. In accordance with Env-Wt 314.06, transfer of this permit to a new owner shall require notification to, and approval of, the NHDES.
7. The permit holder shall ensure that work is done in a way that protects water quality per Env-Wt 307.03; protects fisheries and breeding areas per Env-Wt 307.04; protects against invasive species per Env-Wt 307.05; meets dredging activity conditions in Env-Wt 307.10; and meets filling activity conditions in Env-Wt 307.11.
8. This project has been screened for potential impact to known occurrences of protected species and exemplary natural communities in the immediate area. Since many areas have never been surveyed, or only cursory surveys have been performed, unidentified sensitive species or communities may be present. This permit does not absolve the permittee from due diligence in regard to state, local or federal laws regarding such communities or species. This permit does not authorize in any way the take of threatened or endangered species, as defined by RSA 212-A:2, or of any protected species or exemplary natural communities, as defined in RSA 217-A:3.
9. In accordance with Env-Wt 307.06(a) through (c), no activity shall jeopardize the continued existence of a threatened or endangered species, a species proposed for listing as threatened or endangered, or a designated or proposed critical habitat under the Federal Endangered Species Act, 16 U.S.C. §1531 et seq.; State Endangered Species Conservation Act, RSA 212-A; or New Hampshire Native Plant Protection Act, RSA 217-A.
10. In accordance with Env-Wt 307.02, and in accordance with federal requirements, all work in areas under the jurisdiction of the U.S. Army Corps of Engineers (USACE) shall comply with all conditions of the applicable state general permit.

APPROVED:



Kristin L. Duclos
Wetlands Specialist, Wetlands Bureau
Land Resources Management, Water Division

THE SIGNATURES BELOW ARE REQUIRED TO VALIDATE THIS PERMIT (Env-Wt 314.01).

PERMITTEE SIGNATURE (required)

PRINCIPAL CONTRACTOR SIGNATURE (required)

**NEW HAMPSHIRE
DEPARTMENT OF STATE**



I, David M. Scanlan, Secretary Of State, of the State of New Hampshire, do hereby certify that the Governor and Executive Council, at their meeting on August approved ITEM #133 authorized 227 Market Street, LLC and NH State Port Authority's request to perform work on Piscataqua River in Portsmouth, NH.



In Testimony Whereof, I hereto set my hand and cause to be affixed the Seal of the State of New Hampshire, this twenty-third day of August, in the year of Our Lord, two thousand and twenty-three.

A handwritten signature in cursive script, appearing to read "D. Scanlan".

Secretary of State



The State of New Hampshire
Department of Environmental Services

Robert R. Scott, Commissioner



August 29, 2023



ADL 325 LITTLE HARBOR ROAD TRUST
C/O STEPHEN H ROBERTS ESQ
127 PARROTT AVE
PORTSMOUTH NH 03801

Re: Approved Standard Dredge and Fill Wetlands Permit Application (RSA 482-A)
NHDES File Number: 2022-00789
Subject Property: 325 Little Harbor Rd, Portsmouth, Tax Map #205, Lot #2

Dear Owner:

On August 29, 2023, the New Hampshire Department of Environmental Services (NHDES) Wetlands Bureau approved the above-referenced application to impact 40 square feet (SF) of previously developed upland tidal buffer zone and 949 SF of tidal wetland to remove an existing tidal docking structure and construct a new tidal docking structure consisting of a 6 foot by 65 foot fixed pier connected to a 4 foot by 50 foot ramp connected to a 16 foot by 25 foot float with associated piles. The overall length of this docking structure, seaward of the highest observable tide line, is 123.8 feet, on approximately 3,800 feet of frontage on Lady Isle (Belle Isle) along the Piscataqua River in Portsmouth.

In accordance with RSA 482-A:10, RSA 21-O:14, and Rules Env-WtC 100-200, **any person aggrieved by this decision may file a Notice of Appeal directly with the NH Wetlands Council (Council) within 30 days of the decision date, August 29, 2023.** Every ground claiming the decision is unlawful or unreasonable must be fully set forth in the Notice of Appeal. Only the grounds set forth in the Notice of Appeal are considered by the Council. Information about the Council, including Council Rules, is available at <https://www.nhec.nh.gov/wetlands-council/about>. For appeal related issues, contact the Council Appeals Clerk at (603) 271-6072.

In accordance with RSA 482-A:3, II(a) and Env-Wt 313.02(b), as your project is a major project located in a great pond or in public waters of the state, your application must also be approved by the Governor and the Executive Council. Upon expiration of the appeal period, a redacted copy of the file is submitted to the Governor and the Executive Council for their consideration. Information about the Governor and the Executive Council is available at <https://www.nh.gov/council/>.

Sincerely,

Philip Trowbridge, P.E., Manager
Land Resources Management, Water Division

Enclosure: Copy of Decision

cc: Agent
Municipal Clerk/Conservation Commission
ec: Assistant Administrator, Wetlands Bureau

www.des.nh.gov

29 Hazen Drive • PO Box 95 • Concord, NH 03302-0095
NHDES Main Line: (603) 271-3503 • Subsurface Fax: (603) 271-6683 • Wetlands Fax: (603) 271-6588
TDD Access: Relay NH 1 (800) 735-2964

FILE #2022-00789
ADL 325 LITTLE HARBOR ROAD TRUST
PORTSMOUTH

DECISION DATE:

August 29, 2023

DECISION:

Impact 40 square feet (SF) of previously developed upland tidal buffer zone and 949 SF of tidal wetland to remove an existing tidal docking structure and construct a new tidal docking structure consisting of a 6 foot by 65 foot fixed pier connected to a 4 foot by 50 foot ramp connected to a 16 foot by 25 foot float with associated piles. The overall length of this docking structure, seaward of the highest observable tide line, is 123.8 feet, on approximately 3,800 feet of frontage on Lady Isle (Belle Isle) along the Piscataqua River in Portsmouth.

CONDITIONS:

1. All work shall be done in accordance with the approved plans dated March 7, 2022, and revised through April 7, 2023, by TF Moran, Inc., and last received by the NH Department of Environmental Services (NHDES) on April 28, 2023, in accordance with Env-Wt 307.16.
2. This permit shall not be effective until the permittee records this permit at the Rockingham County Registry of Deeds. Any limitations or conditions in the permit so recorded shall run with the land beyond the expiration of the permit. The permittee shall provide the NHDES with a copy of the permit stamped by the registry with the book and page and date of receipt, in accordance with New Hampshire Administrative Rule Env-Wt 314.02(b) and (c).
3. Pile installation shall occur between November 15 and March 15, to protect anadromous fish as required by Env-Wt 307.06.
4. The ramp and float portions of residential tidal docks shall be seasonal and removed from the water during the non-boating season, in accordance with Env-Wt 606.06(b).
5. Tidal docking installation shall be done by barge or upland to prevent the driving of construction equipment in or through tidal waters/wetlands or on the bottom of the inter-tidal zone, in accordance with Env-Wt 606.05(b).
6. Tidal docking construction shall be done in accordance with the standard conditions in Env-Wt 307.
7. Heavy equipment shall not be operated in any jurisdictional area unless specifically authorized by this permit, in accordance with Env-Wt 307.15(a).
8. In accordance with Env-Wt 307.03(h), equipment shall be staged and refueled outside of jurisdictional areas and in accordance with Env-Wt 307.15.
9. In accordance with Env-Wt 307.03(g)(1), the person in charge of construction equipment shall inspect such equipment for leaking fuel, oil, and hydraulic fluid each day prior to entering surface waters or wetlands or operating in an area where such fluids could reach groundwater, surface waters, or wetlands.
10. In accordance with Env-Wt 307.03(g)(2), the person in charge of construction equipment shall repair any leaks prior to using the equipment in an area where such fluids could reach groundwater, surface waters, or wetlands.
11. In accordance with Env-Wt 307.03(g)(3) and (4), the person in charge of construction equipment shall maintain oil spill kits and diesel fuel spill kits, as applicable to the type(s) and amount(s) of oil and diesel fuel used, on site so as to be readily accessible at all times during construction; and train each equipment operator in the use of the spill kits.

FINDINGS:

1. This project is classified as a major project per Rule Env-Wt 606.17(a)(1), for all new overwater structure construction in tidal waters/wetlands.
2. On April 28, 2023, the Department received correspondence from the NH Fish and Game Department (NHF&G) dated July 21, 2022, and February 24, 2022, stating that provided the proposed work is performed after November 15th and best management practices are utilized, the NHF&G Marine Division "confirms that this project will not adversely affect [the protected anadromous fish species]."

3. NHDES finds that the project as approved and conditioned will not have an unreasonable adverse impact on the value of such areas as sources of nutrients for finfish, crustacea, shellfish and wildlife of significant value, nor will it damage or destroy habitats and reproduction areas for plants, fish and wildlife of importance.
4. On May 3, 2022, the Department received correspondence from the Portsmouth Conservation Commission stating that the Commission recommended the approval of the project.
5. On February 24, 2022, the applicant obtained a statement from the Pease Development Authority, Division of Ports and Harbors regarding the projects impact on navigation and passage stating, "[w]e examined the proposed site and found that the structure will have no negative effect on navigation in the channel," per Rule Env-Wt 603.09.
6. The Department finds that this permit for work to dredge or fill will not 'infringe on the property rights or unreasonably affect the vale or enjoyment of property of abutting owners' and thus meets Rule Env-Wt 313.01(a)(5), and RSA 482-A:11, II.
7. On April 28, 2023, NHDES received a request to waive Rule Env-Wt 606.06(d), to relieve the applicant from the requirement to demonstrate that a proposed residential tidal dock is the least impacting alternative by showing that the subject property is not already served by an existing residential tidal dock at the property.
8. On July 21, 2023, NHDES received a request to waive Rule Env-Wt 606.06(k)(1), to relieve the applicant from the requirement to limit the density of residential tidal docks on the frontage to one structure that meets the property line setback established in RSA 482-A:3, XIII(a) on each frontage.
9. The department finds that the documentation provided by the applicant provides clear and convincing evidence that granting the waivers will not result in either an avoidable adverse impact on the environment or natural resources of the state; an avoidable adverse impact on public health or public safety; nor any impact on abutting properties that is more significant than that which would result from complying with the rule; or a statutory requirement being waived; and any benefit to the public or the environment from complying with the rule is outweighed by the operational or economic costs to the applicant, and thus, that the requirements of Env-Wt 204.05 have been met, and therefore, the requested waivers are granted.
10. NHDES finds that the requirements for a public hearing, as established in RSA 482-A, do not apply as the project will not have a significant environmental impact, as defined in New Hampshire Administrative Rule Env-Wt 104.19, on the resources protected by RSA 482-A, and, is not of substantial public interest, as defined in New Hampshire Administrative Rule Env-Wt 104.32.
11. The Department finds that the project as proposed and conditioned meets the requirements of RSA 482-A and the Wetlands Program Code of Administrative Rules Chapters Env-Wt 100-1000.



The State of New Hampshire
Department of Environmental Services



Robert R. Scott, Commissioner

August 11, 2023

PORTSMOUTH MUNICIPAL CLERK/CONSERVATION COMMISSION
1 JUNKINS AVE
PORTSMOUTH NH 03801



Re: Received Standard Dredge and Fill Wetlands Permit Application (RSA 482-A)
NHDES File Number: 2023-02040
Subject Property: Corporate Drive, Portsmouth, Tax Map #MDL-94 901C, Lot #0303-0006-0000

Dear Sir or Madam:

On July 26, 2023, the New Hampshire Department of Environmental Services (NHDES) Wetlands Bureau received the above-referenced Standard Dredge and Fill Wetlands Permit Application (Application). On August 11, 2023, NHDES determined the Application was administratively complete in accordance with RSA 482-A:3, XIV. *Please note this letter is not a permit or authorization to begin work.*

Pursuant to RSA 482-A:11, III, if notification by a local conservation commission, local river management advisory committee, or the New Hampshire Rivers Council pursuant to this paragraph is not received by the department within 14 days (**August 8, 2023**) following the date the notice is filed with the municipal clerk, the department shall not suspend its normal action, but shall proceed as if no notification has been made.

Please provide a copy of this letter to all local level departments, boards, and commissions. Pursuant to current state laws and regulations, NHDES is not authorized to consider local zoning and regulatory issues pertaining to a project. These issues must be addressed at the local level.

If you have any questions, please contact the Wetlands Bureau at (603) 271-2147.

Sincerely,

Melissa F. Rusinski
Application Receipt Center, Wetlands Bureau
Land Resources Management, Water Division

www.des.nh.gov

RECEIVED
AUG 2 1963
BY _____



The State of New Hampshire
Department of Environmental Services



Robert R. Scott, Commissioner



July 29, 2023

Eversource Energy
Attn: Ashley Friend
13 Legends Drive
Hooksett, New Hampshire 03106

RE: E194 & U181 Structure Replacement Project
Portsmouth & Newington, NH

Permit: AoT-2427

Dear Applicant:

Based upon the plans and application, approved on July 29, 2023, we are hereby issuing RSA 485-A:17 Alteration of Terrain Permit AoT-2427. As part of the processing of this application, DES granted approval to waiving specific requirements of Env-Wq 1503.12(d), Env-Wq 1503.21(d)(6 & 7) and Env-Wq 1504.09, finding that granting the waivers would not have an adverse impact on the environment, public health, public safety, or abutting properties, and that granting the requests is consistent with the intent and purpose of the rules waived. Additional documentation relative to the waivers requested is contained within the file. This permit is subject to the following conditions:

PROJECT SPECIFIC CONDITIONS:

1. Plans by Tighe & Bond, Inc., entitled "Line E194 and U181 Structure Replacement Project", dated July 10, 2023, Notes & Details sheet (Figure: Page 1), dated July 12, 2023, and supporting documentation in the permit file are a part of this approval.
2. **This permit expires on July 29, 2028.** No earth moving activities shall occur on the project after this expiration date unless the permit has been extended by the Department. If an extension is required, the request must be received by the department before the permit expires. The Amendment Request form is available at: <https://www.des.nh.gov/land/land-development>

GENERAL CONDITIONS:

1. Activities shall not cause or contribute to any violations of the surface water quality standards established in Administrative Rule Env-Wq 1700.
2. You must submit revised plans for permit amendment prior to any changes in construction details or sequences. You must notify the Department in writing within ten days of a change in ownership.
3. You must notify the Department in writing prior to the start of construction and upon completion of construction. Forms can be submitted electronically at: <https://www.des.nh.gov/land/land-development>. Paper forms are available at the referenced web address.
4. This permit does not relieve the applicant from the obligation to obtain other local, state or federal permits that may be required (e.g., from US EPA, US Army Corps of Engineers, etc.). Projects disturbing over 1 acre may require a federal stormwater permit from EPA. Information regarding this permitting process can be obtained at: <https://www.epa.gov/npdes/2022-construction-general-permit-cgp>.
5. **Upon completion of construction, a written notice signed by the permit holder and a qualified engineer shall be submitted to the Department, in accordance with Env-Wq 1503.21(c)(1), stating that**

the project was completed in accordance with the approved plans and specifications. If deviations were made, the permit holder shall review the requirements in Env-Wq 1503.21(c)(2).

6. No activity shall occur in wetland areas until the applicable permit is obtained from the Department. Issuance of this permit does not obligate the Department to approve a Wetlands Permit for this project

7. This project has been screened for potential impact to known occurrences of protected species and exemplary natural communities in the immediate area. Since many areas have never been surveyed, or only cursory surveys have been performed, unidentified sensitive species or communities may be present. This permit does not absolve the permittee from due diligence in regard to state, local or federal laws regarding such communities or species. This permit does not authorize in any way the take of threatened or endangered species, as defined by RSA 212-A:2, or of any protected species or exemplary natural communities, as defined in RSA 217-A:3

Sincerely,



Ridgely Mauck, P.E.
Alteration of Terrain Bureau

cc: Portsmouth Planning Board ✓
Newington Planning Board

ec: Tighe & Bond, Inc.



The State of New Hampshire
Department of Environmental Services



Robert R. Scott, Commissioner

July 26, 2023

UNITIL
325 WEST ROAD
PORTSMOUTH NH 03801

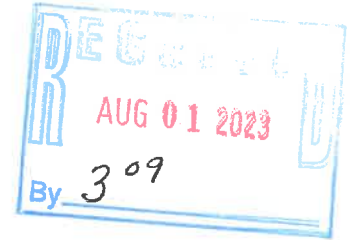

Re: Administratively Incomplete Standard Dredge and Fill Wetlands Permit Application (RSA 482-A)
NHDES File Number: 2023-02040
Subject Property: Corporate Drive, Portsmouth, Tax Map #MDL-94 901C, Lot #0303-0006-0000

Dear Applicant:

On July 26, 2023, the New Hampshire Department of Environmental Services (NHDES) Wetlands Bureau received the above-referenced Standard Dredge and Fill Wetlands Permit Application (Application). On July 26, 2023, the NHDES Wetlands Bureau determined the Application was administratively incomplete, as it did not include the minimum information required under Env-Wt 312.02 for technical review. The following information was missing:

- Copies of certified postal receipts or other proof of receipt of the notices that are required by RSA 482-A:3, I(d) 311.03(b)(13) to the abutter(s).

Please submit all required information to the NHDES Wetlands Bureau within 60 days of the date of this notice to file an administratively complete Application. In accordance with applicable statutes and regulations, a copy of the required information or modified elements of the Application must be provided to the municipal clerk and all other interested parties. If the required information is not received by September 26, 2023, the Application will be denied in accordance with RSA 482-A:3, XIV(a)(1). Please include NHDES Wetlands Bureau file number 2023-02040 with your submission.

If you have any questions, please contact the Wetlands Bureau at (603) 271-2147.

Sincerely,

Melissa F. Rusinski
Program Assistant I, Wetlands Bureau
Land Resources Management, Water Division

cc: UNITIL Property Owner
PROCESS PIPELINE SERVICES Agent
Municipal Clerk/Conservation Commission

www.des.nh.gov

29 Hazen Drive • PO Box 95 • Concord, NH 03302-0095
NHDES Main Line: (603) 271-3503 • Subsurface Fax: (603) 271-6683 • Wetlands Fax: (603) 271-6588
TDD Access: Relay NH 1 (800) 735-2964



The State of New Hampshire
Department of Environmental Services



Robert R. Scott, Commissioner

July 26, 2023

PORTSMOUTH MUNICIPAL CLERK/CONSERVATION COMMISSION
1 JUNKINS AVE
PORTSMOUTH NH 03801

**Re: Received Administratively Incomplete Standard Dredge and Fill Wetlands Permit Application (RSA 482-A)
NHDES File Number: 2023-02040
Subject Property: Corporate Drive, Portsmouth, Tax Map #MDL-94 901C, Lot #0303-0006-0000**

Dear Sir or Madam:

On July 26, 2023, the New Hampshire Department of Environmental Services (NHDES) Wetlands Bureau received the above-referenced Standard Dredge and Fill Wetlands Permit Application (Application). On July 26, 2023, the NHDES determined the Application was administratively incomplete in accordance with RSA 482-A:3, XIV.

Pursuant to RSA 482-A:11, III, if notification by a local conservation commission, local river management advisory committee, or the New Hampshire Rivers Council pursuant to this paragraph is not received by the department within 14 days (**August 8, 2023**) following the date the notice is filed with the municipal clerk, the department shall not suspend its normal action, but shall proceed as if no notification has been made. Please include the NHDES file number on the written notification.

Please provide a copy of this letter to all local level departments, boards, and commissions. Pursuant to current state laws and regulations, the NHDES is not authorized to consider local zoning and regulatory issues pertaining to a project. These issues must be addressed at the local level.

If you have any questions, please contact the Wetlands Bureau at (603) 271-2147.

Sincerely,

Melissa F. Rusinski
Application Receipt Center, Wetlands Bureau
Land Resources Management, Water Division

www.des.nh.gov

29 Hazen Drive • PO Box 95 • Concord, NH 03302-0095
NHDES Main Line: (603) 271-3503 • Subsurface Fax: (603) 271-6683 • Wetlands Fax: (603) 271-6588
TDD Access: Relay NH 1 (800) 735-2964



The State of New Hampshire
Department of Environmental Services



Robert R. Scott, Commissioner

July 14, 2023

CITY OF PORTSMOUTH
680 PEVERLY HILL RD
PORTSMOUTH NH 03801



Re: Approved Standard Dredge and Fill Wetlands Permit Application (RSA 482-A)
NHDES File Number: 2020-02959; Subject Property: 180 Piscataqua Rd, Durham, Tax Map #12, Lot #5-2

Dear Owner:

On July 14, 2023, the New Hampshire Department of Environmental Services (NHDES) Wetlands Bureau approved the above-referenced application to dredge and fill 5,400 square feet within tidal waters and tidal wetlands to replace the subaqueous drinking water transmission line across Little Bay, from Durham to Newington. The project will temporarily impact a total of 78,460 square feet of jurisdictional area during construction, including 2,995 square feet within palustrine emergent wetlands, 26,595 square feet within the tidal buffer zone, 2,120 square feet within tidal marsh, and 46,750 square feet within tidal waters.

Compensatory mitigation is provided for permanent impacts to tidal surface waters as a one-time payment of \$60,839.03 into the Aquatic Resource Mitigation (ARM) Fund within the Salmon Falls - Piscataqua River Watershed account.

In accordance with RSA 482-A:10, RSA 21-O:14, and Rules Env-WtC 100-200, **any person aggrieved by this decision may file a Notice of Appeal directly with the NH Wetlands Council (Council) within 30 days of the decision date, July 14, 2023.** Every ground claiming the decision is unlawful or unreasonable must be fully set forth in the Notice of Appeal. Only the grounds set forth in the Notice of Appeal are considered by the Council. Information about the Council, including Council Rules, is available at <https://www.nhec.nh.gov/wetlands-council/about>. For appeal related issues, contact the Council Appeals Clerk at (603) 271-6072.

In accordance with RSA 482-A:3, II(a) and Env-Wt 313.02(b), as your project is a major project located in a great pond or in public waters of the state, your application must also be approved by the Governor and the Executive Council. Upon expiration of the appeal period, a redacted copy of the file is submitted to the Governor and the Executive Council for their consideration. Information about the Governor and the Executive Council is available at <https://www.nh.gov/council/>.

Sincerely,

Philip Trowbridge, P.E., Manager
Land Resources Management, Water Division

Enclosure: Copy of Decision

cc: Agent
Portsmouth Municipal Clerk/Conservation Commission
Durham Municipal Clerk/Conservation Commission
Newington Municipal Clerk/Conservation Commission
Abutters
ec: Assistant Administrator, Wetlands Bureau

www.des.nh.gov

29 Hazen Drive • PO Box 95 • Concord, NH 03302-0095
NHDES Main Line: (603) 271-3503 • Subsurface Fax: (603) 271-6683 • Wetlands Fax: (603) 271-6588
TDD Access: Relay NH 1 (800) 735-2964

DECISION:

Dredge and fill 5,400 square feet within tidal waters and tidal wetlands to replace the subaqueous drinking water transmission line across Little Bay, from Durham to Newington. The project will temporarily impact a total of 78,460 square feet of jurisdictional area during construction, including 2,995 square feet within palustrine emergent wetlands, 26,595 square feet within the tidal buffer zone, 2,120 square feet within tidal marsh, and 46,750 square feet within tidal waters.

Compensatory mitigation is provided for permanent impacts to tidal surface waters as a one-time payment of \$60,839.03 into the Aquatic Resource Mitigation (ARM) Fund within the Salmon Falls - Piscataqua River Watershed account.

CONDITIONS:

1. All work shall be done in accordance with City of Portsmouth Little Bay Subaqueous Water Transmission Main Permit Drawing plans dated May 2023, by Wright-Pierce, last received by the NH Department of Environmental Services (NHDES) on May 18, 2023; and, in accordance with the Salt Marsh Restoration Plan and narrative dated July 2021, received by NHDES on July 23, 2021, per Env-Wt 307.16.
2. This permit is contingent on the permittee obtaining ownership, construction easements, or written permission from affected property owners to authorize any work outside of the existing right-of-way, per RSA 482-A:11, II and Env-Wt 311.11(d).
3. This permit is contingent on the permittee providing a final planting plan for review and approval by NHDES and the NH Natural Heritage Bureau (NHB), reflecting the recommendations provided by the NHB relative to NHB Datacheck #NHB20-2107. Selected plant species shall be common coastal species, native to NH and suitable to the appropriate habitat (salt tolerant, where specified).
4. Within 30 days of the start of construction sufficient notice shall be provided to affected abutters and property owners, the NHDES Spill Response Section Planning and Preparedness Manager, the NHDES Shellfish Program Manager, local commercial shellfish harvesters, the NH Commercial Fisherman's Association, the Pease Development Authority Division of Ports and Harbors Chief Harbormaster, and any other parties who may be affected by the construction activities, per RSA 482-A:11, II.
5. Work in tidal waters shall occur between November 15 and March 15, to protect fish migration and larval setting stage of fish and shellfish, per Env-Wt 307.10(i).
6. Tidal docking installation shall be done by barge or upland to prevent the driving of construction equipment in or through tidal waters or tidal wetlands, per Env-Wt 606.05(b).
7. No activity shall be conducted in such a way as to cause or contribute to any violation of surface water quality standards, per Env-Wt 307.03(a).
8. All work including management of soil stockpiles, shall be conducted so as to minimize erosion, minimize sediment transfer to surface waters or wetlands, and minimize turbidity in surface waters and wetlands, per Env-Wt 307.03(b).
9. All activities associated with the project shall be conducted in compliance with applicable requirements of RSA 483-B and Env-Wq 1400, the Protected Shoreland, during and after construction, per Env-Wt 307.07.
10. Heavy equipment shall not be operated in any jurisdictional area unless specifically authorized by this permit, per Env-Wt 307.15(a).
11. Equipment shall be staged and refueled outside of jurisdictional areas, per Env-Wt 307.15
12. The person in charge of construction equipment shall: inspect such equipment for leaking fuel, oil, and hydraulic fluid each day prior to entering surface waters or wetlands or operating in an area where such fluids could reach groundwater, surface waters, or wetlands; repair any leaks prior to using the equipment in such areas; maintain oil spill kits and diesel fuel spill kits, as applicable, on site so as to be readily accessible at all times during construction; and, train each equipment operator in the use of the spill kits, per Env-Wt 307.03(g).

MITIGATION:

13. The permit is contingent on submittal of a check for cleared payment in the amount of \$60,839.03 to the Aquatic Resource Mitigation Fund, within the Salmon Falls - Piscataqua River Watershed Account, by the applicant as calculated per Env-Wt 803.07 and RSA 482-A:30. No work is authorized under this approval until the ARM payment is received.
14. In accordance with Env-Wt 807.01(b), the payment shall be received by NHDES within 120 days from the approval decision or NHDES will deny the application.

CONSTRUCTION MONITORING:

15. The project shall be monitored during construction by an on-site certified wetland scientist, or qualified professional, in accordance with the Turbidity Monitoring Plan dated July 2021, received by NHDES on July 23, 2021; and weekly construction monitoring reports shall be provided to NHDES through the duration of the project, per Env-Wt 307.16 and Env-Wt 307.18.
16. The permittee shall submit a report to NHDES within 60-days following completion of the project, that has been prepared by a certified wetland scientist, or qualified professional, containing narrative, exhibits, and photographs, as necessary to report the status of the project area and that describes the stability of and status of impacted jurisdictional areas and including a description of any necessary adjustments; monitoring of erosion, sedimentation and turbidity controls, per Env-Wt 307.18.

POST-CONSTRUCTION MONITORING:

17. The qualified professional shall monitor the restored salt marsh areas for five growing seasons following the completion of the project to ensure that post-construction substrate and vegetation schemes are as close as practicable to pre-construction conditions and the area has been fully restored in accordance with Env-Wt 307.12, per Env-Wt 307.16 and the Salt Marsh Restoration Plan dated July 2021, received by NHDES on July 23, 2021.
18. The qualified professional shall submit annual monitoring reports to NHDES by December 31 of each year for five growing seasons following the completion of the project, per Env-Wt 307.16 and Env-Wt 307.18.
19. The permittee, qualified professional(s), and permittee's contractor(s) shall coordinate with NHDES to adaptively manage the Salt Marsh Restoration plan and to take remedial actions as may be necessary to optimize restoration potential of impacted salt marsh areas. Adaptive management/remedial actions may include, though not be limited to, modifying the hydraulic regime, modifying material gradation and depth, or removal of invasive species, per Env-Wt 307.12.
20. If determined necessary by the permittee, qualified professional(s), the permittee's contractor(s) and NHDES, adaptive management and remedial actions shall only commence after obtaining written approval from the NHDES Wetlands Bureau, per Env-Wt 307.12.

FINDINGS:

1. This project is classified as a major project per Rule Env-Wt 407.02(a), for impacts to tidal waters and tidal wetlands (priority resource areas as defined by Env-Wt 103.66(f)).
2. On September 23, 2021, the department received correspondence from the NH Fish & Game Department, indicating that, based on the proposed plans and information provided, the NHFG Marine Division had no further comments or concerns with the project (NHB identification number: NHB20-2107).
3. On August 23, 2021, the permittee received correspondence from the NH Natural Heritage Bureau (NHB; relative to NHB datacheck #NHB20-2107), indicating that NHB understands "that the cofferdams are temporary and that any resulting impacts to sheet flow of tidal water across the intertidal system will be temporary as well." NHB requested explanation of the constraints that prevented the use of a turbidity curtain in lieu of the temporary cofferdam and trestle system. NHB also provided recommendations related to the final planting plan for restoration of temporary impacts.
4. NHDES finds that, based on site-specific challenges and limitations of effectively implementing a turbidity curtain (anticipated current velocity and water depth) in the areas subject to trench excavation, the approved coffer dam and trestle system are a less impacting alternative. Minimal sediment suspension is expected during trestle and cofferdam installation and removal; and, during excavation of the pipe trench, the coffer dam is expected to retain turbidity and suspended sediments.

5. NHDES finds that this permit is contingent upon the permittee providing a final planting plan for review and approval by NHDES and the NH Natural Heritage Bureau (NHB), reflecting the recommendations provided by the NHB relative to NHB Datacheck #NHB20-2107. Based on local availability, selected plant species will be common coastal species, native to NH and suitable to the appropriate habitat (salt tolerant, where specified).
6. No comments were received by NHDES from the Durham or Newington Conservation Commissions about this application. In correspondence dated July 23, 2021, and throughout the technical review process, the permittee indicated to NHDES that coordination with each municipality was on-going and changes were incorporated to the extent possible.
7. On June 07, 2023, the applicant obtained a statement from the Pease Development Authority, Division of Ports and Harbors regarding the projects impact on navigation and passage stating, "[w]e examined the proposed site and found that the structure will have no negative effect on navigation in the channel," per Rule Env-Wt 603.09.
8. In correspondence dated February 02, 2021, the NH Shellfish Initiative expressed concerned about potential closure of shellfish farms and how farmers will be notified.
9. NHDES finds that the project as approved and conditioned will not have an unreasonable adverse impact on local shellfish harvesters. Harvesters will be provided notice prior to the start of construction to adequately manage their operations accordingly and turbidity will be contained within the approved cofferdam, reducing the risk of sedimentation over nearby shellfish farms.
10. In correspondence dated February 15, 2021, the NH Commercial Fisherman's Association stated that "...without being trenched [the new watermain] would create a 24" wall in its underwater route that could create obstruction to benthic species moving through this area with unknown consequences to these species and related habitat."
11. NHDES finds that the project as approved and conditioned will not have an unreasonable adverse impact on the movement of benthic invertebrates. The existing 20-inch watermains currently rest on the bed of Little Bay. The new 24-inch watermain will be located between the two existing mains. The landward extents of the new watermain on either shoreline will be buried within the intertidal zone.
12. In correspondence dated February 11, 2021, Virgin Oyster Company LLC stated that "...on incoming tides a large eddy forms over the entire farm and it may concentrate any suspended solids produced in dredging on the shoreline."
13. NHDES finds that the project as approved and conditioned, will not have an unreasonable adverse impact on water quality or aquatic habitats. The approved plans include measures to contain turbidity and suspended sediments within the constructed cofferdam, reducing the risk of sedimentation over nearby wetland and tidal habitats, and to actively monitor turbidity outside of the cofferdams to ensure that water quality standards are maintained throughout the duration of work. The project is also subject to review and authorization under the applicable standards of the Section 401 Water Quality Certification program.
14. In correspondence dated April 08, 2021, an attorney on behalf of an abutter to the project asked several clarifying questions about the proposed design, construction methods, jurisdictional boundary delineations, construction easements and appropriate authorization for work outside of existing easements, restoration and stabilization of salt marsh and shoreline impacts.
15. NHDES finds that the requisite construction sequencing details pursuant to RSA 482-A and Env-Wt Chapter 300 and 600 have been included in the approved plans and application materials; and, that the proposed cofferdam and temporary trestle system has been designed to achieve the least environmentally impacting practicable method for installing the new HDPE drinking water main.
16. NHDES finds that the limits of jurisdictional areas have been delineated by a NH Certified Wetland Scientist, as required by Env-Wt 306.05(a)(1).
17. NHDES finds that the project as approved and conditioned will obtain all necessary authorizations from affected property owners to conduct any work in jurisdictional areas outside of the existing right-of-way, per RSA 482-A:11, II and Env-Wt 311.11(d).
18. NHDES finds that the project as approved and conditioned will not have an unreasonable adverse impact on salt marsh. Per the approved Salt Marsh Restoration Plan, existing salt marsh will be removed and preserved during construction. Upon completion of construction, salt marsh will be replaced and monitored for five growing seasons to ensure long term restoration and stabilization of temporarily impacted salt marsh and tidal shoreline.
19. On June 01, 2023, NHDES held a public hearing on the proposed project. Two individuals testified at the hearing. Testimony included comments pertaining to alternative construction methods (i.e., jet plowing) and alteration of tidal currents and local sediment transport processes.

20. NHDES finds that the requisite construction sequencing details pursuant to RSA 482-A and Env-Wt Chapter 300 and 600 have been included in the approved plans and application materials; and, that the proposed cofferdam and temporary trestle system has been designed to achieve the least environmentally impacting practicable method for installing the new HDPE drinking water main. Alternative methods, such as "jet plowing" were previously approved in a different location, subject to different tidal conditions and depths, and for different material/utility types than the subject 24-inch HDPE watermain. The approved construction method is expected to contain turbidity and suspended sediments within the constructed cofferdam, reducing the risk of sedimentation over nearby wetland and tidal habitats, and the permittee will actively monitor turbidity outside of the cofferdams to ensure that water quality standards are maintained throughout the duration of work.
21. NHDES finds that the project as approved and conditioned will not alter tidal currents and sediment transport processes in the vicinity of the project. Native substrate side casted from the trench, within the coffer dam, will be used to backfill the pipeline trench to restore exiting grades. A diver will be deployed to inspect that existing grades are properly restored.
22. NHDES finds that the project as approved and conditioned will not have an unreasonable adverse impact on the value of such areas as sources of nutrients for finfish, crustacea, shellfish and wildlife of significant value, nor will it damage or destroy habitats and reproduction areas for plants, fish and wildlife of importance.
23. The Department finds that the project as proposed and conditioned meets the requirements of RSA 482-A and the Wetlands Program Code of Administrative Rules Chapters Env-Wt 100-1000. No waivers of RSA 482-A or the Wetlands Program Code of Administrative Rules Chapters Env-Wt 100-1000 were requested or approved under this permit action.
24. Per Rule Env-Wt 313.04(a) and Env-Wt 605.03(a), compensatory mitigation is required as this project will result in 5,400 square feet of permanent impact to tidal surface waters.
25. Per Rule Env-Wt 801.03(b), the applicant is offering an in-lieu mitigation payment as specified in RSA 482-A:30, as permittee-responsible compensatory mitigation is not practicable.
26. The payment into the ARM fund shall be deposited in the NHDES fund for the Salmon Falls - Piscataqua Rivers watershed per RSA 482-A:29.
27. The Department decision is issued in letter form and upon receipt of the ARM fund payment, the Department shall issue a posting permit in accordance with Env-Wt 803.11(c). Work under this approval is not authorized until the ARM payment is received.
28. Per Rule Env-Wt 803.10(e), the department has accepted the proposal for an in-lieu mitigation payment as the proposal meets the requirements of Env-Wt 803.10(b), and of Env-Wt 803.10(c), and the mitigation type or combination of mitigation types listed in Rule Env-Wt 803.08(a) Table 800-1 that are available in the same watershed as the impacts for compensating jurisdictional area losses are not practicable.



The State of New Hampshire
Department of Environmental Services

Robert R. Scott, Commissioner



July 12, 2023



ADL 325 LITTLE HARBOR ROAD TRUST
C/O STEPHEN H ROBERTS ESQ
127 PARROTT AVE
PORTSMOUTH NH 03801

Re: Request for More Information – Standard Dredge and Fill Wetlands Permit Application (RSA 482-A)
NHDES File Number: 2023-01406
Subject Property: 325 Little Harbor Rd, Portsmouth, Tax Map #204, Lot #5

Dear Applicant:

On July 12, 2023, the New Hampshire Department of Environmental Services (NHDES) Wetlands Bureau reviewed the above-referenced Standard Dredge and Fill Wetlands Permit Application (Application). Pursuant to RSA 482-A:3, XIV(a)(2) and Rules Env-Wt 100 through 900, NHDES Wetlands Bureau determined the following additional information is required to complete its evaluation of the Application:

Property Owner:

1. The plans indicate that impacts will occur outside of the limits of the applicant's property interest on Portsmouth Tax Map #204, Lot #5, a parcel owned by Lisa A. Grondhal Revocable Trust as indicated on the provided abutters list. Please include the following as a part of the response to this letter:
 - a. Provide a revised application form that includes the information for the affected property owner where impacts are proposed as required in Section 6 of the application form in accordance with Env-Wt 311.04(b).
 - b. Provide a copy of the recorded deed for subject property at Portsmouth Tax Map 204, Lot #5 with the associated book and page numbers as recorded in the Rockingham County Registry of Deeds in accordance with Env-Wt 311.06(e).
 - c. In accordance with Env-Wt 311.11(d), because the applicant is not the owner of the property where these impacts are proposed, the affected property owner must also sign and date the application:

Grant of Right:

2. As this project will require fill within public waters for the purpose of creating land, this project will require Grant of Right in accordance with RSA 482-A:17. Please provide all information and documentation necessary to petition the Governor and Executive Council for Grant of Right. Additionally, please note that this project will require a public hearing in accordance with RSA 482-A:17.

Chapter Env-Wt 900:

3. As this project involves a crossing on a tidal watercourse, it is considered a tier 4 stream crossing in accordance with Env-Wt 904.06(a). Please revise provide all required supplementary information required for a tier 4 stream crossing replacement and make all necessary plan revisions in accordance with Env-Wt 900.

Please note that the proposed tier 4 stream crossing does not meet the definition of a span structure as required in accordance with Env-Wt 904.06(b). Please either redesign the project in accordance with the design criteria in Env-Wt 904.06 and Env-Wt 904.07 or submit an alternative design request as specified in Env-Wt 904.10 as part of the response to this letter.

www.des.nh.gov

29 Hazen Drive • PO Box 95 • Concord, NH 03302-0095
NHDES Main Line: (603) 271-3503 • Subsurface Fax: (603) 271-6683 • Wetlands Fax: (603) 271-6588
TDD Access: Relay NH 1 (800) 735-2964

4. Plans for a tier 4 stream crossing must be dated and bear the signature and seal of the professional engineer who prepared or had responsibility for and approved them, as required by RSA 310-A:18 in accordance with Env-Wt 904.06(e).

Mitigation:

5. The permanent impacts to the designated prime wetland (Prime Wetland 61B) and the duly-designated 100-foot prime wetland buffer are considered permanent impacts to priority resource areas (PRAs) in accordance with Env-Wt 103.66, Env-Wt 306.05(a)(2)d., and Env-Wt 306.05(a)(2)e., therefore compensatory mitigation is required for these impacts in accordance with Env-Wt 311.01(c)(2), Env-Wt 313.04(a)(1), and Env-Wt 605.03(a). Please submit a complete compensatory mitigation proposal that includes all information required in accordance with Env-Wt 312.04 as a part of the response to this letter:
6. Records indicate that a mitigation pre-application meeting for this project was held on January 17, 2023, while the application was received 129 days later by NHDES on May 26, 2023. Applicants must attend a pre-application meeting with the department to discuss the proposed project and all applicable requirements and to coordinate the review of the compensatory mitigation proposal at least 30 days but not more than 90 days before submitting the application in accordance with Env-Wt 311.02(d). Please contact me at Kristin.Duclos@des.nh.gov or (603) 559-1516 to schedule another mitigation pre-application meeting to discuss the mitigation proposal for this project.

Natural Heritage Bureau (NHB) Datacheck:

7. The Natural Heritage Bureau (NHB) Datacheck (NHB23-0723) identified sensitive plant species on the site. Please finalize coordination with the NHB and provide a copy of the transplanting and monitoring plan that has been approved by NHB as a part of the response to this letter in accordance with Env-Wt 311.06(g).

Plans:

8. Please show the following on all existing and proposed plan sheets:
 - a. The limits of Portsmouth Prime Wetland 61B and the duly-established 100-foot prime wetland buffer in accordance with Env-Wt 311.05(a)(13) and identify the square footage of any permanent impacts taking place within these resources.
 - b. The location of the 100-year flood boundary zone and water elevation as shown on the applicable FEMA Flood Insurance Rate Map in accordance with Env-Wt 311.05(a)(16) and Env-Wt 610.04(b).
 - c. The tidal water depths depicted as a line with associated elevation at highest observable tide, mean high tide, and mean low tide, and the date and tide height when the depths were measured on all plan and elevation views in accordance with Env-Wt 603.07(b)(2) and Env-Wt 603.07(c)(3).
9. The certified wetland scientist that stamped the plans is different from the certified wetland scientist that is identified in plan note #7 on the Existing Conditions Plan Sheet S-01. Please address this discrepancy.

Please submit the required information as soon as practicable. Pursuant to RSA 482-A:3, XIV(a)(2), **the required information must be received by NHDES Wetlands Bureau within 60 days of the date of this request (no later than September 10, 2023), or the Application will be denied.** Should additional time be necessary to submit the required information, an extension of the 60-day time period may be requested. Requests for additional time must be received prior to the deadline in order to be approved. In accordance with applicable statutes and regulations, the applicant is also expected to provide copies of the required information to the municipal clerk and all other interested parties.

Pursuant to RSA 482-A:3, XIV(a)(3), NHDES Wetlands Bureau will approve or deny the Application within 30 days of receipt of all required information, or schedule a public hearing, if required by RSA 482-A or associated rules.

www.des.nh.gov

29 Hazen Drive • PO Box 95 • Concord, NH 03302-0095

NHDES Main Line: (603) 271-3503 • Subsurface Fax: (603) 271-6683 • Wetlands Fax: (603) 271-6588

TDD Access: Relay NH 1 (800) 735-2964

File Number: 2023-01406

July 12, 2023

Page 3 of 3

If you have any questions, please contact me at Kristin.Duclos@des.nh.gov or (603) 559-1516.

Sincerely,



Kristin L. Duclos
Wetlands Specialist, Wetlands Bureau
Land Resources Management, Water Division

cc: Portsmouth Municipal Clerk/Conservation Commission
TFMoran, Inc., c/o Jason R. Aube



The State of New Hampshire
Department of Environmental Services



Robert R. Scott, Commissioner

July 3, 2023

KATARA LLC
274 MILLER AVE
PORTSMOUTH NH 03801

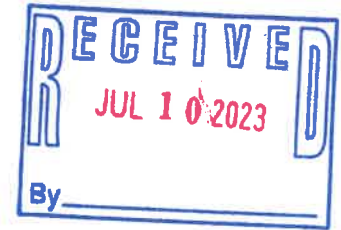

Re: Approved Standard Dredge and Fill Wetlands Permit Application (RSA 482-A)
NHDES File Number: 2022-02721
Subject Property: 70 Pleasant Point Dr, Portsmouth, Tax Map #207, Lot #15

Dear Owner:

On July 03, 2023, the New Hampshire Department of Environmental Services (NHDES) Wetlands Bureau approved the above-referenced application to impact 96 square feet (SF) of previously developed upland tidal buffer zone and 906 SF of tidal wetland to construct a tidal docking structure consisting of a 5 foot by 6 foot access stairs connected to a 6 foot by 72 foot fixed pier connected to a 4 foot by 30 foot ramp connected to a 10 foot by 40 foot float with associated piles and float stops. The overall length of this docking structure, seaward of the highest observable tide line, is 101 feet, on approximately 360 feet of frontage along the Piscataqua River in Portsmouth.

In accordance with RSA 482-A:10, RSA 21-O:14, and Rules Env-WtC 100-200, **any person aggrieved by this decision may file a Notice of Appeal directly with the NH Wetlands Council (Council) within 30 days of the decision date, July 03, 2023.** Every ground claiming the decision is unlawful or unreasonable must be fully set forth in the Notice of Appeal. Only the grounds set forth in the Notice of Appeal are considered by the Council. Information about the Council, including Council Rules, is available at <https://www.nhec.nh.gov/wetlands-council/about>. For appeal related issues, contact the Council Appeals Clerk at (603) 271-6072.

In accordance with RSA 482-A:3, II(a) and Env-Wt 313.02(b), as your project is a major project located in a great pond or in public waters of the state, your application must also be approved by the Governor and the Executive Council. Upon expiration of the appeal period, a redacted copy of the file is submitted to the Governor and the Executive Council for their consideration. Information about the Governor and the Executive Council is available at <https://www.nh.gov/council/>.

Sincerely,

Philip Trowbridge, P.E., Manager
Land Resources Management, Water Division

Enclosure: Copy of Decision

cc: Agent
Municipal Clerk/Conservation Commission
Abutters
ec: Assistant Administrator, Wetlands Bureau

www.des.nh.gov

29 Hazen Drive • PO Box 95 • Concord, NH 03302-0095
NHDES Main Line: (603) 271-3503 • Subsurface Fax: (603) 271-6683 • Wetlands Fax: (603) 271-6588
TDD Access: Relay NH 1 (800) 735-2964

FILE #2022-02721
KATARA LLC
PORTSMOUTH

DECISION DATE:
July 03, 2023

DECISION:

Impact 96 square feet (SF) of previously developed upland tidal buffer zone and 906 SF of tidal wetland to construct a tidal docking structure consisting of a 5 foot by 6 foot access stairs connected to a 6 foot by 72 foot fixed pier connected to a 4 foot by 30 foot ramp connected to a 10 foot by 40 foot float with associated piles and float stops. The overall length of this docking structure, seaward of the highest observable tide line, is 101 feet, on approximately 360 feet of frontage along the Piscataqua River in Portsmouth.

CONDITIONS:

1. All work shall be done in accordance with the approved plans dated June 27, 2022, and revised through March 6, 2023, by TF Moran, Inc., and last received by the NH Department of Environmental Services (NHDES) on April 4, 2023, in accordance with Env-Wt 307.16
2. This permit shall not be effective until the permittee records this permit at the Rockingham County Registry of Deeds. Any limitations or conditions in the permit so recorded shall run with the land beyond the expiration of the permit. The permittee shall provide the NHDES with a copy of the permit stamped by the registry with the book and page and date of receipt, in accordance with New Hampshire Administrative Rule Env-Wt 314.02(b) and (c).
3. Pile installation shall occur between November 15 and March 15, to protect anadromous fish as required by Env-Wt 307.06.
4. The ramp and float portions of residential tidal docks shall be seasonal and removed from the water during the non-boating season, in accordance with Env-Wt 606.06(b).
5. Tidal docking installation shall be done by barge or upland to prevent the driving of construction equipment in or through tidal waters/wetlands or on the bottom of the inter-tidal zone, in accordance with Env-Wt 606.05(b).
6. Tidal docking construction shall be done in accordance with the standard conditions in Env-Wt 307.
7. Heavy equipment shall not be operated in any jurisdictional area unless specifically authorized by this permit, in accordance with Env-Wt 307.15(a).
8. In accordance with Env-Wt 307.03(h), equipment shall be staged and refueled outside of jurisdictional areas and in accordance with Env-Wt 307.15.
9. In accordance with Env-Wt 307.03(g)(1), the person in charge of construction equipment shall inspect such equipment for leaking fuel, oil, and hydraulic fluid each day prior to entering surface waters or wetlands or operating in an area where such fluids could reach groundwater, surface waters, or wetlands.
10. In accordance with Env-Wt 307.03(g)(2), the person in charge of construction equipment shall repair any leaks prior to using the equipment in an area where such fluids could reach groundwater, surface waters, or wetlands.
11. In accordance with Env-Wt 307.03(g)(3) and (4), the person in charge of construction equipment shall maintain oil spill kits and diesel fuel spill kits, as applicable to the type(s) and amount(s) of oil and diesel fuel used, on site so as to be readily accessible at all times during construction; and train each equipment operator in the use of the spill kits.

FINDINGS:

1. This project is classified as a major project per Rule Env-Wt 606.17(a)(1), for all new overwater structure construction in tidal waters/wetlands.
2. On May 5, 2023, the Department received correspondence from the Natural Heritage Bureau (NHB) dated May 5, 2023, stating that "NHB has no further concerns regarding this project."
3. On September 20, 2022, the Department received correspondence from the NH Fish and Game Department (NHFG&G) dated July 12, 2022, stating that "[w]ith construction occurring during the normal [November 15- March 15 federal] dredge window we feel there will be no impacts to [the protected anadromous fish species]."

4. NHDES finds that the project as approved and conditioned will not have an unreasonable adverse impact on the value of such areas as sources of nutrients for finfish, crustacea, shellfish and wildlife of significant value, nor will it damage or destroy habitats and reproduction areas for plants, fish and wildlife of importance.
5. On October 3, 2022, the Department received correspondence from the Portsmouth Conservation Commission stating that the Commission recommended the approval of the project provided "the applicant will ensure that gangway and float storage be off site" and "Kayak storage should be moved to the float or pier to be away from the protected salt marsh habitat and to decrease foot traffic within that area."
6. On June 29, 2022, the applicant obtained a statement from the Pease Development Authority, Division of Ports and Harbors regarding the projects impact on navigation and passage stating, "[w]e examined the proposed site and found that the structure will have no negative effect on navigation in the channel," per Rule Env-Wt 603.09.
7. The Department finds that the project as proposed would not 'infringe on the property rights or unreasonably affect the value or enjoyment of property of abutting owners' and thus, would not be prohibited by RSA 482-A:11,II.
8. NHDES finds that the requirements for a public hearing, as established in RSA 482-A, do not apply as the project will not have a significant environmental impact, as defined in New Hampshire Administrative Rule Env-Wt 104.19, on the resources protected by RSA 482-A, and, is not of substantial public interest, as defined in New Hampshire Administrative Rule Env-Wt 104.32.
9. The Department finds that the project as proposed and conditioned meets the requirements of RSA 482-A and the Wetlands Program Code of Administrative Rules Chapters Env-Wt 100-1000. No waivers of RSA 482-A or the Wetlands Program Code of Administrative Rules Chapters Env-Wt 100-1000 were requested or approved under this permit action.

