

HDC

ADMINISTRATIVE APPROVALS

June 14, 2023

- | | | |
|----|------------------------------|------|
| 1. | 135 Daniel Street, Unit A102 | -TBD |
| 2. | 18 Walden Street | -TBD |
| 3. | 46-64 Maplewood Avenue | -TBD |
| 4. | 17 Pray Street | -TBD |

1. 135 Daniel Street, Unit A102 - TBD

Background: The applicant is seeking approval for the installation of a vent terminal on the side of the structure (where other pipes and venting exist).

Staff Comment: TBD

Stipulations:

1. _____
2. _____
3. _____

135 Daniel Street

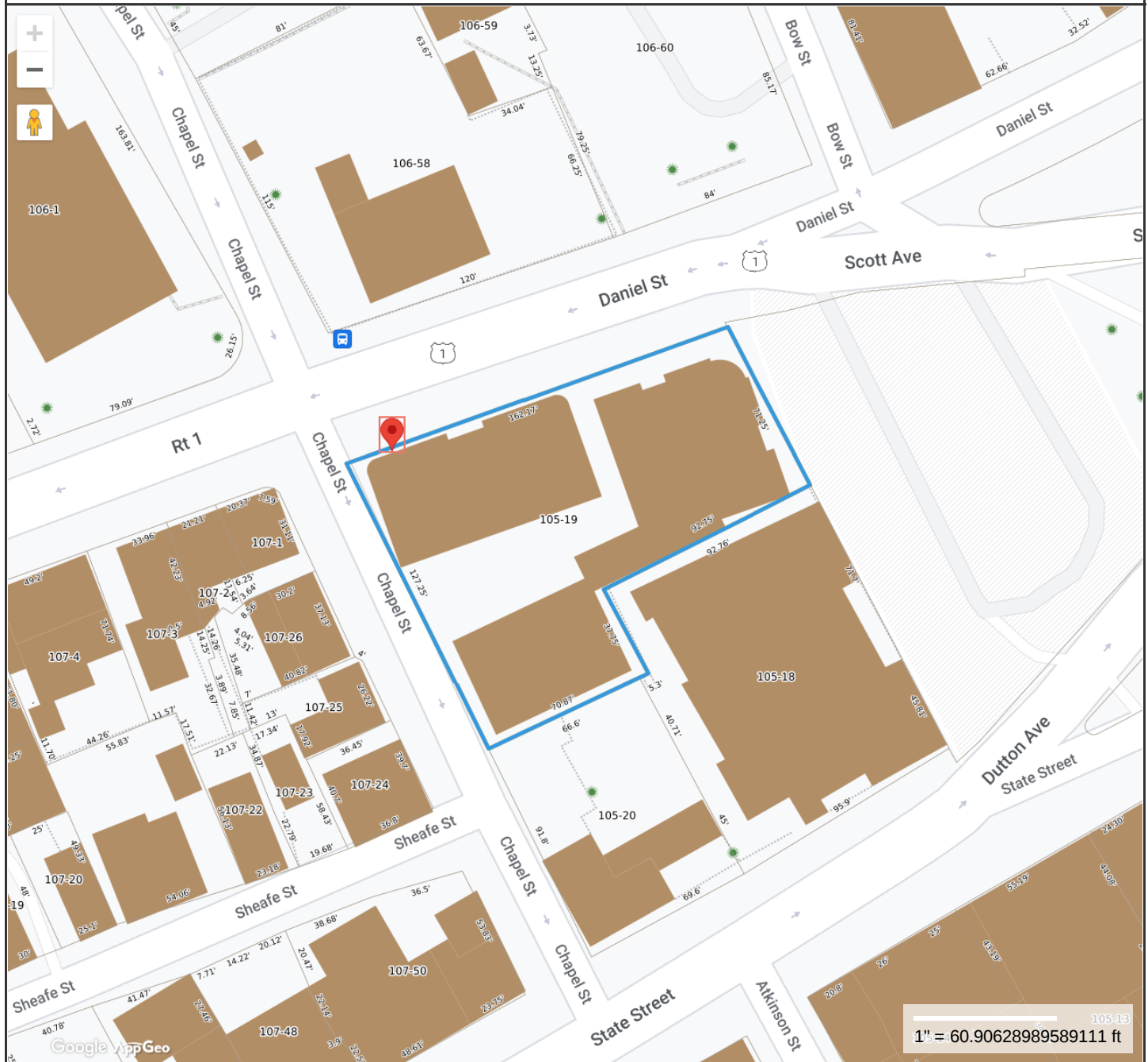

Property Information

Property ID 0105-0019-A102
Location 135 DANIEL ST #A102
Owner BADAMI FAMILY TRUST



MAP FOR REFERENCE ONLY NOT A LEGAL DOCUMENT

City of Portsmouth, NH makes no claims and no warranties, expressed or implied, concerning the validity or accuracy of the GIS data presented on this map.

Geometry updated 09/21/2022
 Data updated 3/9/2022

Print map scale is approximate. Critical layout or measurement activities should not be done using this resource.



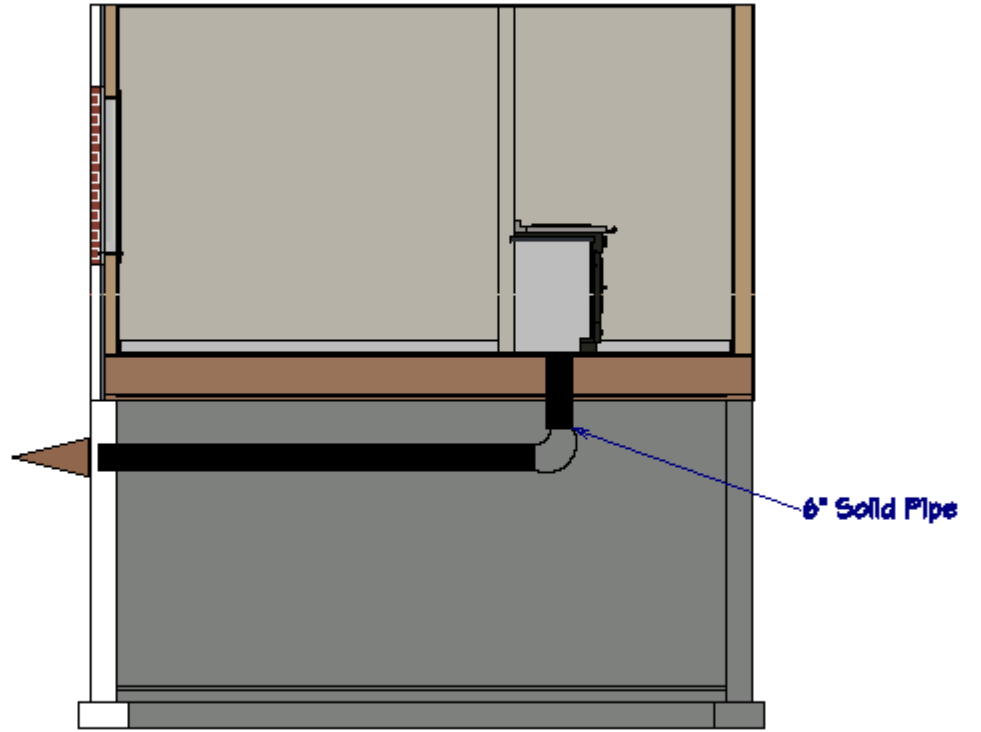

2. 18 Walden Street

- TBD

Background: The applicant is seeking approval for the installation of a condenser. The Commission requested the applicant return with a screening option.

Staff Comment: TBD

Stipulations:

1. _____
2. _____
3. _____

Proposal from contractor:

4/11/23, 8:07 PM

Proposal

 East Coast HVAC

CALL US TODAY
(603) 430-9414

Your Proposal Option 1

Scott Day

Address: 18 Walden Street Portsmouth, NH 03801

Phone: (303) 818-2323

Email: scottday1033@gmail.com

Consultation Code: ENGVACGRL

Date Presented: Mar 8, 2023

Date Accepted: Mar 15, 2023

Presented by: Josh Davis

Phone: (603) 430-9414

Email: joshd@eastcoasthvac.com

About Us

We are a family-owned and operated company that was established in 1986. We specialize in the sales, service and installation of residential and light commercial heating and air conditioning systems including Mitsubishi Electric Ductless (<https://eastcoasthvac.com/ductless-heating-air-conditioning/>). Our technicians are factory trained and certified specialists in the HVAC field and specialists with a variety of furnace and boiler repair experience. We stand behind everything we do with warranties to ensure that you're never left without assistance. Our promise is to provide you with the highest quality service and installation at guaranteed competitive prices with superior post-project service. That's why we are one of the most recognized HVAC companies in the Greater Seacoast area of New Hampshire and Southern Maine. Don't pay more than necessary for your heating and air conditioning needs, call East Coast and Pay Fair.



Fully licensed, insured, and here for you 24/7!!

PROPOSAL NOTE

****EXCLUDES ELECTRICAL UPGRADE PRICING****

Our electrician would need to be involved on the proper set up that will allow you to power this equipment safely. I do not know what the overall final pricing will be, on top of this cost. let me be clear again, i do not think changing the panel to one with more space solves your electrical issues. I think this stems from not having a large enough

service to the home. Adding in another double pole 25amp breaker (this system) will cause even more issues without some sort of change.

Master bedroom: 6,000 btu wall mount

Nursery: 6,000 btu wall mount

First Floor: 12,000 btu wall mount

System

Mitsubishi MXZ Ductless 2 Ton

Subtotal: **\$14,300.00**
See total investment below

EQUIPMENT

1 ITEMS



Category: Outdoor Unit

Name: Mitsubishi Ductless M-Series Multi-Zone (3) Outdoor Heat Pump Unit 24K BTU

Number:

INCLUDES

4 ITEMS



Category: Mitsubishi Wall Mounted M-Series GL Models (Heat Pump) / Quantity: 1

Name: Mitsubishi Ductless M-Series 12000 Btu Heat Pump Wall Mounted (Matches MUZ-GL)

Number:



Category: Mitsubishi Wall Mounted M-Series GL Models (Heat Pump) / Quantity: 2

Name: Mitsubishi Ductless M-Series 6000 Btu Heat Pump Wall Mounted (Matches MUZ-GL)

Number:



Category: Services / Quantity: 1

Name: 100% Satisfaction Guarantee

Number:



Category: Services / Quantity: 1

Name: Mitsubishi Elite Diamond Contractor & 12-Year Warranty

Number:

WHAT YOU'LL GET

31 ITEMS

2.5 Day Installation - Your system will take us roughly 2.5 days to complete!

Condenser Mount: We will help you choose the best mounting option for the outdoor unit. The two most commonly used are a foundation wall mount, or a pad and stand set on crushed stone. Either way, our main goal is to make the outdoor installation professional and clean.

Ductless (Small AMP) Power Up Level 1 - Our licensed electricians will run a new and complete line voltage feed from your existing electrical panel, to your new outdoor unit. This includes everything needed, right from the breaker, to an outdoor rated disconnect switch, and into the unit itself. BONUS! We include a surge protector with every installation, to protect your Mitsubishi investment during power spikes or outages. This line item DOES NOT include any upgrades to your existing electrical services, or existing electrical panel(s). Any service upgrades or sub-panels that are including in your pricing, will be included as a separate line item in the installation items. **Please note that ALL Ductless installations in the State of NH require switches at the indoor unit!!**

Ductless Drainage: Your system will produce water in the summer, as it dehumidifies and cools off the home. Each one of your indoor heads comes equipped with the proper drainage, which is generally a combination of plastic corrugated and PVC piping.

Quantity: 3

Ductless Unit Line Set Installation Per 10FT

Quantity: 16

Our Installations always include the required town permitting and inspection fees, so you can rest assured that you are safe and compliant.

System Pressure Testing & Evac Pump Down - We take our AC lines seriously! Your pricing includes an industry standard dry nitrogen pressure-test of the line sets, and an evacuation and pump down process that will leave your lines as clean and dry as physically possible. This sets your system up for success in the long-term, with lines that are tight and free of refrigerant leaks.

White Fortress Enclosure 3.5" (Per 10FT) - To keep the exterior impact to a minimum, we will hide your lines in a decorative enclosure, that can also be painted to match the home. Our installers are always as creative as possible, to keep these lines neat and clean.

Quantity: 7

INVESTMENT DETAILS

Nursery line set run to be as close to the side to hide as much as possible, can be painted to match.



Bathroom unit on second floor

Living room unit on the first floor

Master Bedroom Line run
Can be painted to match color.

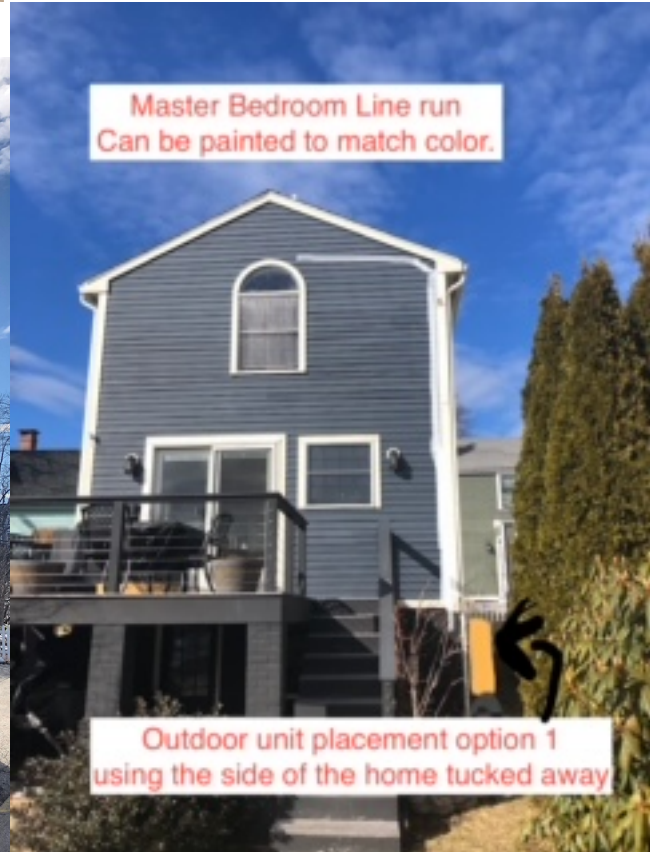

Outdoor unit placement option 1
using the side of the home tucked away

*Bathroom unit will not be installed. Contactor drew this to show what it would look like.

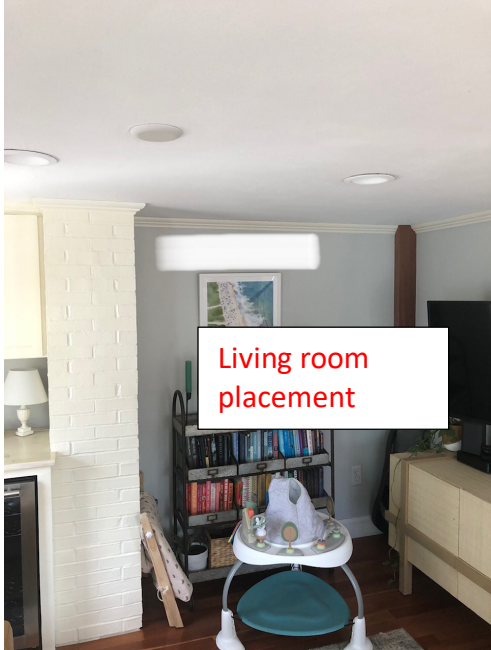

Living room placement

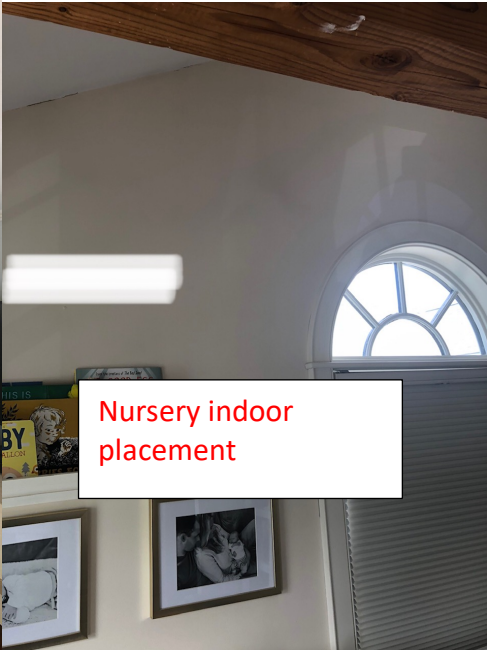

Nursery indoor placement



Living room exterior piping

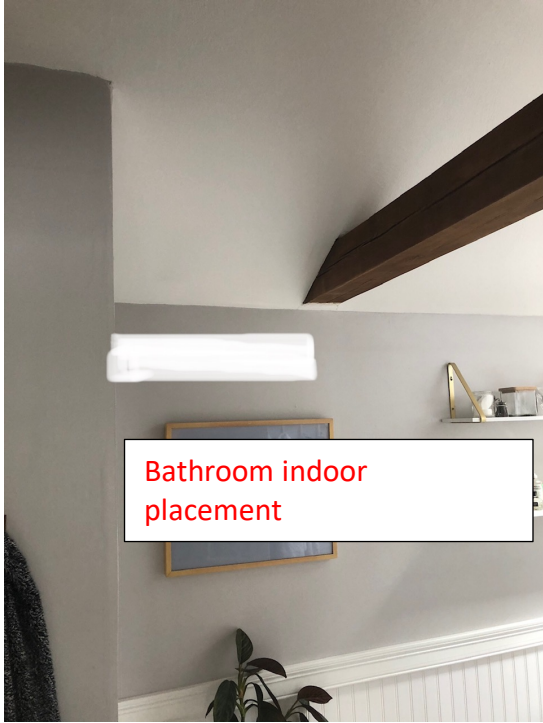

Bathroom indoor placement

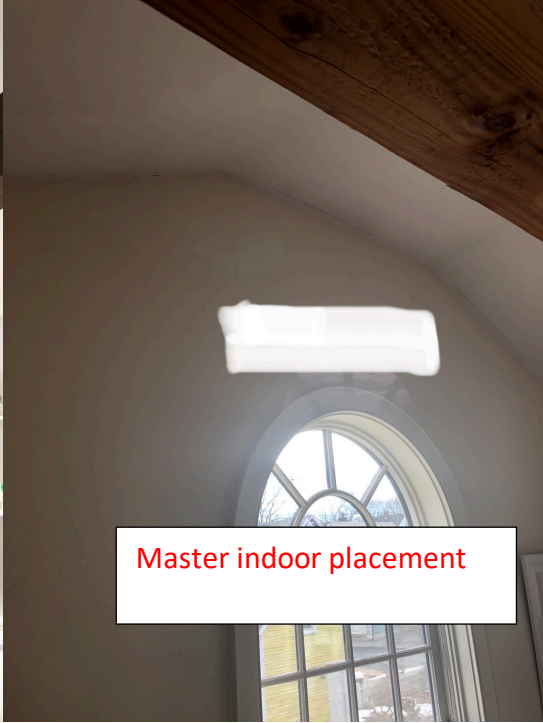

Master indoor placement



Example of proposed lattice style screening.

18 Walden Street

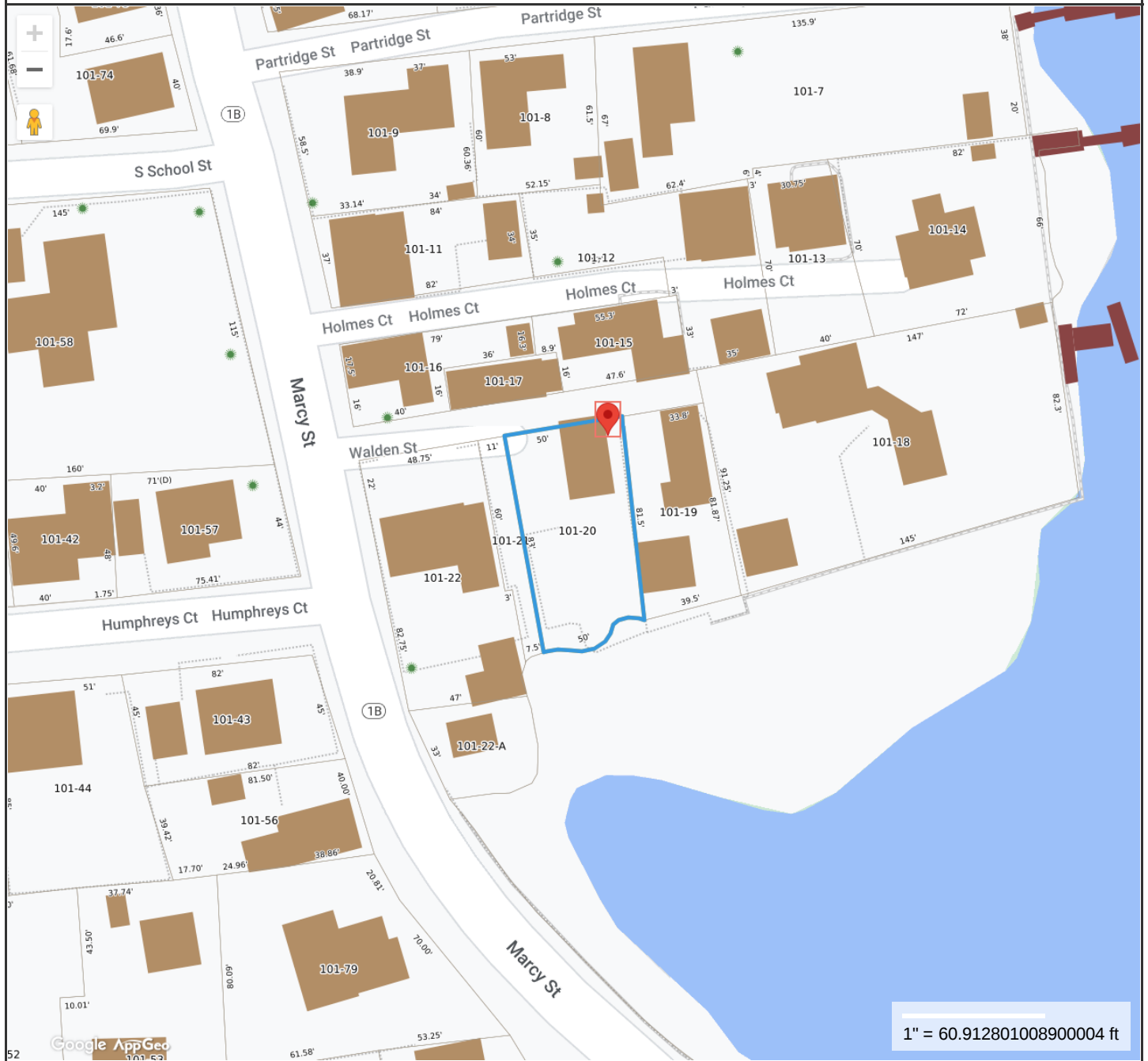

Property Information

Property ID 0101-0020-0000
Location 18 WALDEN ST
Owner ROBINSON ELISABETH S K REVOCABLE TRUST



**MAP FOR REFERENCE ONLY
NOT A LEGAL DOCUMENT**

City of Portsmouth, NH makes no claims and no warranties, expressed or implied, concerning the validity or accuracy of the GIS data presented on this map.

Geometry updated 09/21/2022
Data updated 3/9/2022

Print map scale is approximate. Critical layout or measurement activities should not be done using this resource.

3. 46-64 Maplewood Avenue - TBD

Background: The applicant is seeking approval for the installation of multiple HVAC condensers with screening.

Staff Comment: TBD

Stipulations:

1. _____
2. _____
3. _____

46-64 Maplewood Avenue



Property Information

Property ID 0125-0002-000A
Location 46 MAPLEWOOD AVE
Owner THIRTY MAPLEWOOD LLC



**MAP FOR REFERENCE ONLY
NOT A LEGAL DOCUMENT**

City of Portsmouth, NH makes no claims and no warranties, expressed or implied, concerning the validity or accuracy of the GIS data presented on this map.

Geometry updated 09/21/2022
Data updated 3/9/2022

Print map scale is approximate. Critical layout or measurement activities should not be done using this resource.

1. HVAC Screening (similar to proposed style).







4. 17 Pray Street

- TBD

Background: The applicant is seeking approval for exterior roof/wall repairs.

Staff Comment: TBD

Stipulations:

1. _____
2. _____
3. _____