

C0960-006
April 7, 2021

Mr. Dexter Legg, Chair
City of Portsmouth Planning Board
1 Junkins Avenue
Portsmouth, New Hampshire 03801

**Re: Request for Site Review, Conditional Use & Amended Subdivision Permits
Proposed Multi-Family Development, 105 Bartlett Street, Portsmouth, NH**

Dear Chairman Legg:

On behalf of Iron Horse Properties, LLC, we are pleased to submit one (1) set of hard copies and one electronic file (.pdf) of the following information to support a request for a Site Review Permit, Lot Line Revision Permit, Conditional Use Permit for Shared Parking, and a Wetland Conditional Use Permit for the above referenced project:

- Site Plan Set (full size) last revised March 10, 2021;
- TAC & CC Stipulation Response Report, dated March 10, 2021;
- Site Plan Application Checklist, dated March 10, 2021
- Subdivision Application Checklist, dated March 10, 2021
- Drainage Analysis, last revised March 10, 2021;
- Building Renderings, last revised April 7, 2021;
- Constraints Exhibit, last revised January 20, 2021;
- Buffer Impact Exhibit, last revised March 10, 2021;
- Public Open Space Exhibit, dated March 10, 2021;
- Site Plan Comparison Exhibit March 10, 2021;
- Grade Plane Exhibit, last revised March 10, 2021;
- Truck Turning Exhibits, last revised March 10, 2021;
- Subdivision Exhibit, last revised January 20, 2021;
- Bartlett Street Water Main Abandonment Plan, dated March 8, 2021;
- Trip Generation Memorandum last revised December 23, 2020;
- Wetland Delineation and Functions & Values Report last revised March 10, 2021;
- Photo Log of Existing Buffer Vegetation & Invasive Species dated January 19, 2021;
- Environmental Summary Memorandum, dated November 4, 2020;
- Estimated Water Demand Summary, dated January 20, 2021;
- Eversource Will Serve Letter, dated May 20, 2020;
- Until Will Serve Letter, dated April 17, 2020;
- Waste Management Letter, dated February 9, 2021;
- Green Building Statement, dated March 10, 2021;
- Site Lighting Fixture Cut Sheets

PROJECT SUMMARY

Existing Conditions

The project is located at 105 Bartlett Street consisting of properties identified as Map 157 Lots 1 & 2, Map 164 Lots 1 & 4-2, and a private roadway lot. The properties are bound by



Bartlett Street, the railroad and the North Mill Pond. The properties include 2,000+/- linear feet of tidal wetlands and buffers along the North Mill Pond. The limited functions and values of these areas are described in the enclosed Wetland Delineation Assessment and Functions and Values Report and the existing vegetation and invasive species of these areas are located in the enclosed Photograph Log.

The urban site has history of railroad and industrial use. The front portions of the site closest to Bartlett Street currently include the Ricci Supply buildings with paved parking areas and a private roadway that extend up the top of bank along the North Mill Pond. Currently, the stormwater for these paved areas either sheet flow directly into the North Mill Pond with no treatment or is collected in an old combined sewer overflow (CSO) system contributing burden to the City's sewer collection and treatment systems during rainfall events.

The rear portion of the site, which includes the proposed development area, consists of an industrial building converted to a brewery & a dog daycare. A vacant machine shop with paving, compacted gravel and building also are located in close proximity to the top of the North Mill Pond bank. The rear of the site includes derelict railroad structures that pose a safety hazard. The 100-foot tidal wetland buffer is almost entirely previously disturbed urban upland which has been neglected, fallen into disrepair, and overgrown with invasive species. The existing condition in the rear of the site has long been an attractive nuisance with a history of debris, homeless encampments, and crime.

The properties in question include a significant portion of the City of Portsmouth's long planned improvements to the shoreline of the North Mill Pond, the concept of which has been a focus of the City's planning for years. It was included in the Portsmouth Bicycle and Pedestrian Plan in 2014 and the North End Vision Plan in 2015. Many of the stated goals set forth in the City's Master Plan in 2016 called for its creation. The Final Report on the North Mill Pond Greenway and Community Park was issued in 2019.

The Final Plan calls for "a linear greenway and community park along the North Mill Pond which will create a new north-south pedestrian and bicycle connection from Bartlett Street to Market Street. This multi-use public path with civic amenities in envisioned to be constructed along the southeast shoreline of the pond, will include wetland restoration and pond edge stabilization and is anticipated and constructed through a series of public-private partnerships with private landowners."

The City's Zoning Ordinance was amended in 2016 to create an overlay district specifically allowing the construction of taller buildings in the area as incentive for real estate developers to join in these important public private partnerships.

Proposed Redevelopment

In 2018, a proposed subdivision was granted for the subject parcels and included a private road lot with cul-de-sac. The proposed project will revise the prior approved lot lines by relocating the cul-de-sac closer to Bartlett Street in a location that is currently an existing parking area for the brewery/dog daycare building. The amended subdivision will result in a 4.72-acre property where the existing brewery/dog day care building and vacant machine shop currently are located. This 4.72-acre property will be the location of the proposed multi-family development and, along the shore of North Mill Pond, will be the construction of the long planned public bicycle and pedestrian path as well as valuable new accessible open space along the water's edge.

Commercial Area

The front portion of the site will continue to be an existing commercial area that consists of the Ricci Supply buildings with associated parking improvements and a private road. This

portion of the site will be improved by pulling the private road further away from the top of North Mill Pond bank, implementing traffic and pedestrian improvements to the private road and adding landscape areas to reduce impervious surface. In addition, new stormwater management improvements will be constructed on this portion of the site. New stormwater collection systems will include deep sump catch basins with oil separator hoods and stormwater treatment units. The new systems will eliminate the existing CSO which has long been an initiative of the Department of Public Works across the City and will provide stormwater treatment where none is provided in the existing condition.

Multi-family Development Area

The proposed development area consists of three (3) multi-family apartment buildings depicted as Building A, B and C on the Site Plan. The three (3) buildings will include a total of 152 dwelling units with parking below Buildings A and B. The project includes associated site improvements that consist of the private road cul-de-sac adjacent to Building C, surface parking, pedestrian access, utilities, dark-sky friendly lighting, landscaping and stormwater management systems that provide treatment for runoff. The three (3) proposed buildings will provide additional housing stock to the City that is walkable to downtown, a theme that is consistent throughout the Master Plan.

The proposed development area has unique site conditions that include close proximity to the North Mill Pond; no build view corridors required by zoning that extend from perpendicular City streets located across the railroad; 15-foot side yard setback due to the adjacent railroad where none is typically required in the CD-4W district; and a 25-foot municipal sewer easement for a large sewer pipe that conveys wastewater flow for the City's west end to the Deer Street pump station. These unique conditions put constraints on the applicant's ability to locate buildings within the developable upland area. As shown in the enclosed Constraints Exhibit, the applicant has located the three (3) proposed buildings within the site constraints. The buildings are located in a manner that still pulls the building footprints further back from existing condition, locates surface parking away from the pond along the railroad and creates expansive public open space in an urban setting along the North Mill Pond.

The existing condition of the development property does not provide any stormwater treatment. The proposed development will provide stormwater management improvements which are described in further detail in the enclosed Drainage Analysis. The following is a summary:

- Proposed treatment to runoff from the new buildings and surface parking will be provided via stormwater treatment units. In addition, an underground detention system has been incorporated into the design to address concerns raised by the Conservation Commission regarding temperature of the runoff from the surface parking area. The underground detention system will detain and slowly release runoff for a 24-hour draw down time in order regulate temperature of runoff before discharging it to the North Mill Pond. An additional benefit of the underground detention system is that it will also reduce peak rates of runoff to the North Mill Pond even though peak rate reduction is not required for direct discharges to tidal waters.
- Stormwater treatment measures have been implemented in the rear of the buildings where the public park and trail will be located. Yard drains in the open space between building B & C and along portions of the trail will capture runoff and put them thru a treatment unit. Runoff from the public park area had been designed to flow to a rain garden. The rain garden will not only serve as stormwater treatment but also will be planted as an aesthetically pleasing central feature in the public park and will provide pollinator habitat.
- Porous asphalt has been incorporated into North Mill Pond trail design as requested by the Conservation Commission and City Staff.

As part of the original 2018 Subdivision Approval for these lots, a Traffic Study was prepared by Pernaw, Inc. and peer reviewed by the City's consultant who confirmed the results. This original study included projections for future multi-family development on this parcel. Enclosed with this package is an updated Trip Generation Memorandum prepared by Pernaw, Inc. dated December 23, 2020 for the latest 152-unit program. The memorandum provides a comparison of the trip generation for the program included in the 2018 Subdivision Approval and the current Site Plan. The memorandum demonstrates that the current development proposal will generate less vehicle-trips during the peak hour periods than the program studied as part of the 2018 Subdivision Approval. In addition, the traffic generation contemplated in the 2018 approval was used as background for the Traffic Analysis that was prepared for the West End Yards project. The West End Yards project resulted in traffic improvements to Bartlett Street and Cate Street that will direct traffic to the Route 1 By-Pass via the extension of Cate Street to the Borthwick Avenue intersection. Thus, off-site traffic improvements that would support this project have already been approved by the Planning Board and currently being constructed.

Open Space & Buffer Enhancement

The project is located in the West End Incentive Overlay District. The applicant will be providing 47,703 SF of Greenway Community Space which will be located from the North Mill Pond mean high water line to the 50-foot wetland buffer setback. Providing this community space will contribute towards the City realizing a goal of the Master Plan to create public access along the North Mill pond with a multi-use trail. This Greenway Community Space is 23.2% of the development parcel, exceeding the 20% required by the Zoning Ordinance. In addition to the community space, the applicant is also proposing a 23,552 SF public park adjacent the Greenway Community Space. The total public open space the project will create is 71,255 SF which is 35% of the development parcel area as shown in the enclosed Public Open Space Exhibit. Overall, the project will be providing 58.1% open space on the development lot where only 15% is required by zoning.

The project is providing buffer enhancement with the removal of invasive species and proposed plantings. The 100-foot tidal buffer zone currently consists of the existing buildings, paved roadway and parking areas, large compacted gravel areas, two small second growth wooded areas, and a 25-foot vegetated buffer zone. Much of the existing vegetation on the site consists of invasive species including Norway Maples, Buckthorn, Autumn Olive, Multiflora Rose and some Bittersweet. With the exception of the Norway Maples, which provide valuable canopy cover and screening, invasive species in the areas of construction and within the 25-foot vegetated buffer will be removed. Disturbed areas will be planted with either a native fescue grass mix (Areas shown as lawn on the Landscape Plan) or a New England Wildlife Conservation Seed Mix (Areas within the 25-foot vegetated buffer). The proposed development area will be planted with a mixed buffer of native trees, and drifts of a mix of native and ornamental (not native) shrubs and groundcovers. The majority of the proposed buffer plantings that are within the 100-foot buffer are native. In addition, a centrally located rain garden provides additional pollinator habitat with 90% of its plantings being native.

The project will provide an overall improvement in the 100-foot tidal wetland buffer by pulling parking and building further away from the North Mill Pond and by reducing overall impervious surface as summarized in Table 1 below. In addition to the summary in Table 1 below, detailed calculations of buffer impacts for the existing and proposed condition are depicted in the enclosed Buffer Impact Exhibit by both individual lot and overall project.

Table 1 - 100-Foot Tidal Buffer Impacts

Overall Buffer Impact Area		
Wetland Buffer Setback	Existing Impact	Proposed Impact
0 - 25 FT	12,788 SF	6,788 SF
25 - 50 FT	30,478 SF	22,394 SF
50 - 100 FT	66,844 SF	52,543 SF
Total Impact	110,110 SF	81,725 SF
NET BUFFER IMPROVEMENT		28,385 SF

Section 10.1017.24 of the Zoning Ordinance which indicates “Where feasible, the application shall include removal of impervious surfaces at least equal in area to the area of impervious surface impact. The intent of this provision is that the project will not result in a net loss of pervious surface within a jurisdictional wetland buffer.” As shown in Table 1, the proposed project far exceeds this requirement by providing a 0.65-acre reduction in impervious surface.

Land-Use Permit Applications

Permitting Timeline

The applicant is pleased to provide the enclosed information to support requests to the Planning Board to grant the following land-use permits:

- Site Plan Review
- Lot Line Revision
- Conditional Use Permit for Shared Parking
- Wetland Conditional Use Permit

The enclosed information has been prepared and/or revised in response to comments and feedback received over the past 19 months from the Planning Board, Technical Advisory Committee (TAC), Conservation Commission and public comment during the local land-use permitting process. The following is a summary of meetings with the various land use-boards and public:

1. September 4, 2019 – Meeting with the neighborhood
2. September 10, 2019 – TAC Work Session
3. September 11, 2019 – CC Work Session
4. September 19, 2019 – PB Conceptual Consultation
5. February 20, 2020 – PB Conceptual Consultation
6. March 19, 2020 – PB Design Review
7. May 5, 2020 – TAC Meeting
8. May 13, 2020 – CC Regular Meeting
9. June 2, 2020 – TAC Meeting
10. November 4, 2020 – CC Regular Meeting
11. December 1, 2020 – TAC Meeting
12. December 7, 2020 – CC Site Walk



13. February 2, 2021 – TAC Meeting

14. February 10, 2021 – CC Regular Meeting

In addition to the local land-use permits, the project will also require the following approvals from the New Hampshire Department of Environmental Services (NHDES):

- Alteration of Terrain Permit
- Shoreland Protection Permit
- Wetland Impact Permit

The applicant is in the process of working with NHDES to obtain these approvals. On April 15, 2020, the applicant had an initial Wetland Permit pre-application design meeting with NHDES to review the project. Given the number of plan revisions and improvements that have occurred in response to City and public feedback since the original meeting on April 15, 2020, the applicant recently had a second pre-application design meeting to review the project updates. The applicant has one more pre-application meeting scheduled for March 18, 2021 with NHDES to review the project's mitigation proposal. Following this last pre-application meeting, the applicant will formally file the NHDES permit applications.

Response to Land-Use Board & Public Comments

As noted above, the last time the project was before the Planning Board was on March 19, 2020 for Preliminary Design Review. The following is summary of improvements to design made in response to feedback from the various land-use boards and public since that time:

- Reduced density from 174 dwelling units to 152 dwelling units.
- Eliminated the two (2) story portion of Building A from the CD4-L1 district, further reducing buffer impact and shifting density away from the McDonough Street neighborhood. In doing so, a view corridor for Salem Street has essentially been created for the abutting neighbors and neighborhood, though not required by zoning.
- Revised the shape and reduced the footprint for Building C. The prior footprint mirrored the existing brewery/dog daycare building. This revision eliminates footprint in the buffer and creates an open space courtyard between Building B and C.
- Reduced surface parking on the development lot from 134 to 95 spaces. This further reduces buffer impact and avoids disturbance to the wooded area located in the vicinity of the Cabot Street view corridor.
- Re-aligned the path around the building by pulling it away from the North Mill Pond and into public park further reducing buffer impact. The path has been designed in a manner that minimizes asphalt to the extent feasible while addressing fire department comments to provide safe emergency access around the buildings. In addition, the path has been designed as porous asphalt to provide stormwater treatment to runoff on the path.
- Provided additional buffer enhancement measures with additional native plantings and groundcovers, incorporated invasive species removal measures and planted the 25-foot vegetated buffer along the North Mill Pond with a conservation seed mix that is only mowed periodically. The locations and types of invasive species have been identified in the plan set and bank stabilization measures have been incorporated where disturbance will occur for the invasive species removal and construction of the stormwater outfalls.
- An updated Trip Generation Memorandum prepared by Pernaw, Inc. dated December 23, 2020 was submitted to the City for peer review for the latest 152-unit program. The memorandum included a comparison of the trip generation for the program

included in the 2018 Subdivision Approval and the current Site Plan. The memorandum demonstrates that the current development proposal will generate approximately -39 (AM) and -52 (PM) fewer vehicle-trips during the peak hour periods than the program studied as part of the 2018 Subdivision Approval. The City's peer reviewer concurred with these results in a January 12, 2021 peer review letter.

Lot Line Revision Permit

The project is located at 105 Bartlett Street consisting of properties identified as Map 157 Lots 1 & 2, Map 164 Lots 1 & 4-2, and a private roadway lot. In 2018, a proposed subdivision was granted for the subject parcels and included a private road lot with cul-de-sac. The proposed project will modify the private road lot by relocating the cul-de-sac closer to Bartlett Street in a location that is currently the existing parking area for the brewery/dog daycare building. The front commercial parcels where the Ricci Supply buildings are located (Map 164 Lot 1 & Map 157 Lot 2) will be largely unchanged with only slight modifications resulting from the revisions to the private road lot. The lot line revisions will result in a 4.72-acre property where the existing brewery/dog day care building and vacant machine shop are currently located. This 4.72-acre parcel (Map 157 Lot 1) will be the location of the proposed multi-family development. A 2.75-acre parcel of land (Map 164 Lot 4-2) will remain undeveloped to the north of the multi-family development parcel.

Site Plan Review Permit

The project will require a Site Plan Review Permit for the site improvements described above in the project summary. The project has previously been before the Planning Board three (3) times for Conceptual Consultation and Preliminary Design Review. In addition, the project has been before the Technical Advisory Committee (TAC) five (5) times. On February 2, 2021, TAC recommended to the Planning Board that a Site Plan Review Permit be granted with stipulations. Enclosed with this package is a Stipulation Report addressing each of the TAC stipulations of approval.

Conditional Use Permit for Shared Parking

A Conditional Use Permit for parking on a separate lot is requested for the project. The project meets the parking requirements by sharing parking between the two (2) lots as shown on the enclosed Site Plans. A total of 210 parking spaces are required to meet the Zoning requirements.

190 of the proposed parking spaces are located on the development lot. 95 of those spaces are provided in the surface parking lot that will be located outside the 100-foot buffer between the proposed buildings and the railroad. In addition, the project will construct 95 spaces under Buildings A & B in effort to reduce impervious surface and reduce buffer impact.

The private road will be improved with traffic, pedestrian, and bicycle improvements. The road will include parking along the road and cul-de-sac. The cul-de-sac which is adjacent to Building C includes 8 parking spaces that will be designated as visitor spaces for the project. In addition, the portion road immediately south of the cul-de-sac will include 12 parallel parking spaces. These 20 proposed spaces on the private road that are in close proximity to the development parcel are included in the project's total parking count of 210 spaces provided. A Conditional Use Permit is required to include these spaces in the total count because the private road is a separate lot form the development parcel.

Conditional Use Permit of Wetland Buffer

Through the course of the land-use permitting process, the applicant has continued to be responsive to comments regarding buffer impact and concerns with density. The applicant

has submitted five (5) versions of the Site Plan to the Conservation Commission for review from the Conceptual Site Plan reviewed at the September 2019 Work Session through the last Conservation Commission meeting on February 9, 2021, in which the commission voted to recommend approval to the Planning Board for Wetland Conditional Use Permit.

The following includes a summary of four prior (4) iterations of the Site Plan previously submitted to the Conservation Commission and the latest enclosed package as it relates to improvement in the buffer and reduction in density.

Table 2 – Overall Project Buffer Impact Reduction

Submission Date	Existing Condition Buffer Impact (SF)	Overall Project Buffer Impact (SF)	Net Buffer Impact (SF)	Density (# of dwelling units)
09/11/2019	119,808	146,157	26,349	272
04/29/2020	110,110	95,121	(14,989)	174
05/27/2020	110,110	97,739	(12,371)	174
10/28/2020	110,110	89,170	(20,940)	170
03/10/2021	110,110	81,725	(28,385)	152

As depicted in Table 2, the applicant has continued to make a good faith effort to be responsive to comments from the local land-use boards and public by conceding allowed density and further improving buffer impact for the overall project that far exceeds the net zero requirements of Section 10.1017.24.

Based on the above described and enclosed materials, the following addresses how the proposed project warrants the granting of a Wetland Conditional Use Permit by satisfying the following six (6) criteria for approval in Section 10.1017.50 of the Zoning Ordinance:

(1) The land is reasonably suited to the use, activity or alteration.

The subject properties are within the CD4-W and CD4-L1 Zoning Districts (Character Districts). The proposed development parcel meets the requirements of the Zoning Ordinance and does not require any relief. The urban site is largely previously disturbed in the 100-foot tidal wetland buffer. The existing condition of the development includes large amounts of debris, a great deal of invasive species and derelict structures that pose a safety hazard. This area of the site has long been an attractive nuisance with a history of homeless encampments and crime. The proposed project will result in impervious surface reduction in the buffer, buffer enhancement, and will provide public access along North Mill Pond which is a goal of the City’s Master Plan.

(2) There is no alternative location outside the wetland buffer that is feasible and reasonable for the proposed use, activity or alteration.

The proposed development area has unique site conditions that include close proximity to the North Mill Pond; no build view corridors required by zoning that extend from perpendicular City streets located across the railroad; 15-foot side yard setback due to the adjacent railroad where none is required in the CD-4W district; and a 25-foot municipal sewer easement for large sewer pipe that conveys wastewater flow for the City’s west end to the Deer Street pump station. These unique conditions put constraints



on the applicant's ability to locate buildings within the developable upland area. The redevelopment is located within a feasible and reasonable manner that pulls the building footprints further back from existing condition, locates surface parking away from the pond along the railroad and creates expansive public open space in an urban setting along the North Mill Pond. As described above, the applicant has made a continued effort to reduce buffer impact and density in response to feedback from the local land-use boards and public during the local land-use permitting process.

(3) *There will be no adverse impact on the wetland functional values of the site or surrounding properties.*

There will be no adverse impact to surrounding properties as this property has long been an urban site with a history of railroad, industrial and commercial uses. The project has been designed in a manner that conforms with the requirements of the Zoning Ordinance. The project will reduce traffic from the original 2018 Subdivision approval. The project will provide public access to the North Mill Pond for the surrounding properties where none currently exists which is a goal of the City's Master Plan.

There will be no adverse impact on the wetland functional values of the site as the existing condition is largely previously disturbed upland riddled with debris and derelict structures that pose a safety hazard. The existing condition includes impervious surfaces near or at the top of North Mill Pond bank throughout much of the 100-foot tidal buffer. The proposed project will reduce buffer impact, remove invasive species in the 25-foot buffer and construction areas, and provide added value by creating public open space for recreation along the North Mill Pond.

(4) *Alteration of the natural vegetative state or managed woodland will occur only to the extent necessary to achieve construction goals.*

The proposed project is only altering the natural vegetated state to the extent necessary. The project will be removing invasive species in the locations of construction and in the 25-foot vegetated except for the Norway Maple, which provide valuable canopy cover and screening. As described above, the enclosed supplemental information identifies the location of these invasive species and includes stabilization practices for their removal and for the construction of the stormwater outfalls.

(5) *The proposal is the alternative with the least adverse impact to areas and environments under the jurisdiction of this Section.*

The applicant has continuously worked to reduce 100-foot tidal wetland buffer impacts in response to feedback received throughout the permitting process. The project will reduce buffer impact by conceding allowed density and by pulling footprints away from the North Mill Pond to the extent feasible given the site constraints. The project includes underground parking and creates 1.63-acres of public open space area along the North Mill Pond which contribute toward a 0.65-acre net reduction in impervious surface within the buffer. Also, the applicant has conducted environmental studies on the property which are summarized in the enclosed Environmental Summary Memorandum previously submitted to and reviewed with the Conservation Commission. The applicant will remediate all identified recognized environmental conditions in accordance with applicable law.

(6) *Any area within the vegetated buffer strip will be returned to a natural state to the extent feasible.*

The project is providing buffer enhancement with the removal of invasive species and installation of plantings around the buildings and within the 100-foot tidal wetland buffer.

The only other disturbance within the 0ft to 25ft buffer setback is for the construction of the three (3) stormwater outfalls. These outfalls will discharge treated stormwater to the North Mill Pond where no treatment currently exists. Stabilization practices have been included in the enclosed plans for of removal invasive species and construction of the outfalls.

Conclusion

We trust the above described and enclosed materials address the criteria and requirements for the Planning Board to grant a Site Plan Review Permit, Lot Line Revision Permit, Conditional Use Permit for Shared Parking and Wetland Conditional Use Permit for the proposed project. The proposed project meets requirements of the Zoning Ordinance. The proposed project achieves the goals of City's Master Plan to provide public access along the North Mill Pond with a Greenway Community Space and to provide buffer enhancement. In addition, the proposed buildings have been located in a manner within the unique site constraints to provide additional public benefit with an urban public park located along the Community Space Greenway in the rear of Building A and B.

In the past 19 months, the applicant has in good faith, continued to respond to feedback from the community and local land-use boards. As shown in the enclosed information, the latest proposal will provide additional housing stock for the City but will reduce density from earlier proposals, reduce traffic generation from the prior 2018 approvals, reduce buffer area impacts, improve stormwater management, enhance the North Mill Pond tidal wetland buffer and provide public benefit in the form of open space along the North Mill Pond. Based on this, the applicant respectfully requests approval for the various land-use permits noted above.

We respectfully request to be placed on the Planning Board agenda for March 18, 2021. If you have any questions or need any additional information, please contact Patrick Crimmins by phone at (603) 988-8066 or by email at pmcrimmins@tighebond.com.

Sincerely,
TIGHE & BOND, INC.



Patrick M. Crimmins, PE
Senior Project Manager

Enclosures

Copy: Clipper Traders, LLC (via E-mail)
Iron Horse Properties, LLC (via E-mail)
Portsmouth Lumber & Hardware, LLC (via E-mail)

PROPOSED MULTI-FAMILY DEVELOPMENT

105 BARTLETT STREET PORTSMOUTH, NEW HAMPSHIRE

JANUARY 2, 2020

LAST REVISED: MARCH 10, 2021

LIST OF DRAWINGS		
SHEET NO.	SHEET TITLE	LAST REVISED
	COVER SHEET	03/10/2021
1 OF 5	LOT LINE RELOCATION PLAN	01/19/2021
2 OF 5	LOT LINE RELOCATION PLAN	01/19/2021
3 OF 5	LOT LINE RELOCATION PLAN	01/19/2021
4 OF 5	LOT LINE RELOCATION PLAN	01/19/2021
5 OF 5	LOT LINE RELOCATION PLAN	01/19/2021
C-101	OVERALL EXISTING CONDITIONS AND DEMOLITION PLAN	03/10/2021
C-101.1	EXISTING CONDITIONS AND DEMOLITION PLAN	03/10/2021
C-101.2	EXISTING CONDITIONS AND DEMOLITION PLAN	03/10/2021
C-102	OVERALL SITE PLAN	03/10/2021
C-102.1	SITE PLAN	03/10/2021
C-102.2	SITE PLAN	03/10/2021
C-102.3	BASEMENT LEVEL SITE PLAN	03/10/2021
C-103.1	GRADING, DRAINAGE, AND EROSION CONTROL PLAN	03/10/2021
C-103.2	GRADING, DRAINAGE, AND EROSION CONTROL PLAN	03/10/2021
C-104.1	UTILITIES PLAN	03/10/2021
C-104.2	UTILITIES PLAN	03/10/2021
C-105.1	PHOTOMETRIC PLAN	03/10/2021
C-105.2	PHOTOMETRIC PLAN	03/10/2021
C-201.1	ROADWAY PLAN & PROFILE	03/10/2021
C-201.2	ROADWAY PLAN & PROFILE	03/10/2021
C-301.1	UTILITY EASEMENT PLAN	03/10/2021
C-301.2	UTILITY EASEMENT PLAN	03/10/2021
C-302	ACCESS EASEMENT PLAN	03/10/2021
C-501	EROSION CONTROL NOTES AND DETAILS SHEET	03/10/2021
C-502	DETAILS SHEET	03/10/2021
C-503	DETAILS SHEET	03/10/2021
C-504	DETAILS SHEET	03/10/2021
C-505	DETAILS SHEET	03/10/2021
C-506	DETAILS SHEET	03/10/2021
C-507	DETAILS SHEET	03/10/2021
C-508	DETAILS SHEET	03/10/2021
C-509	DETAILS SHEET	03/10/2021
L-1	SITE LANDSCAPE PLAN	01/20/2021
L-2	FOUNDATION PLANTING PLAN	01/20/2021
1 OF 3	BUILDING ELEVATION PLAN	03/10/2021
2 OF 3	BUILDING ELEVATION PLAN	03/10/2021
3 OF 3	BUILDING ELEVATION PLAN	03/10/2021

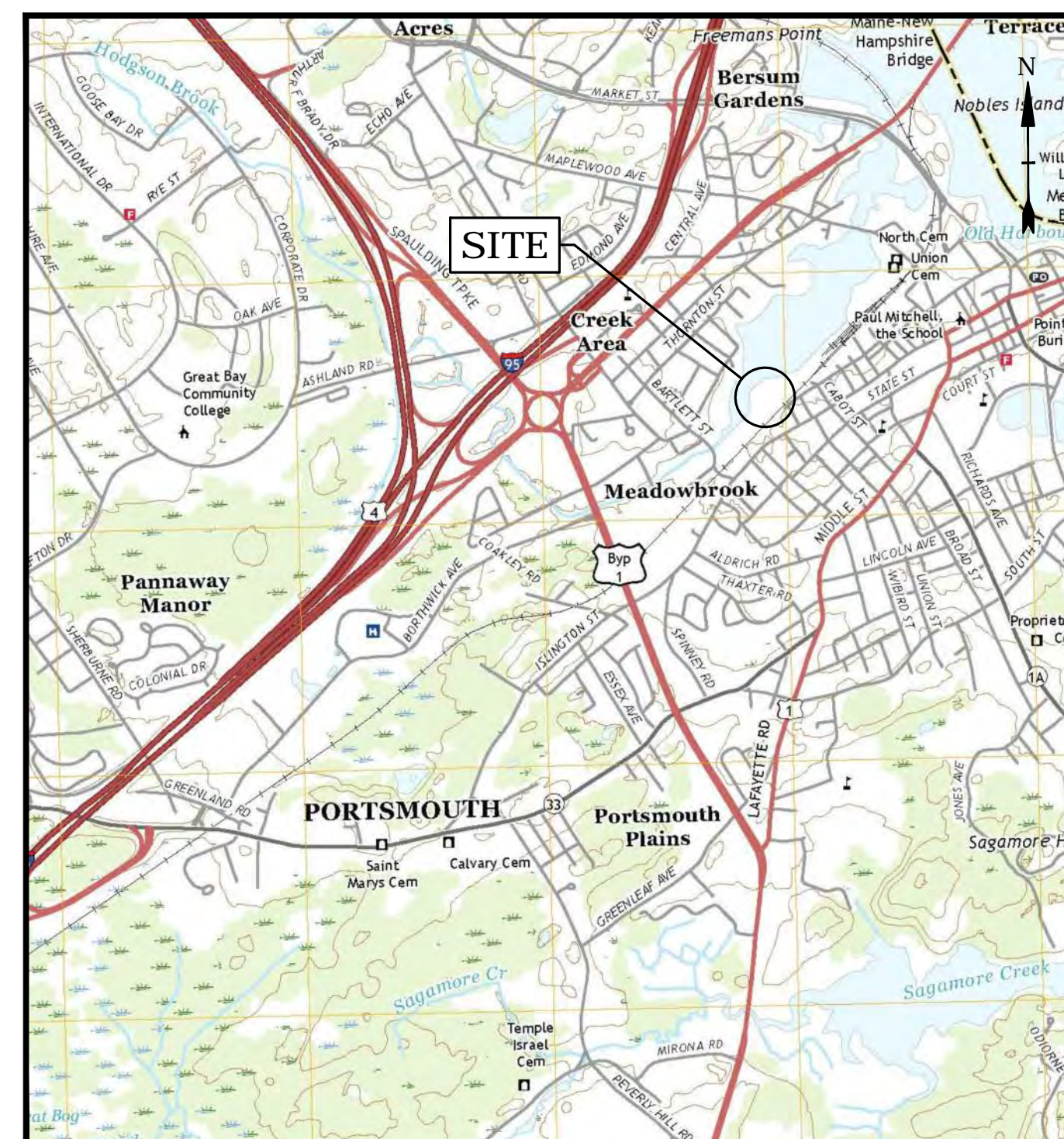

LOCATION MAP
SCALE: 1" = 2000'

PREPARED BY:

Tighe & Bond

177 CORPORATE DRIVE
PORTSMOUTH, NEW HAMPSHIRE 03801
603-433-8818

APPLICANT:

IRON HORSE PROPERTIES, LLC
105 BARTLETT STREET
PORTSMOUTH, NEW HAMPSHIRE 03801

OWNERS:

TAX MAP 157, LOT 1
CLIPPER TRADERS, LLC
105 BARTLETT STREET
PORTSMOUTH, NEW HAMPSHIRE 03801

TAX MAP 164, LOT 4-2
IRON HORSE PROPERTIES, LLC
105 BARTLETT STREET
PORTSMOUTH, NH 03801

TAX MAP 157 LOT 2
TAX MAP 164, LOT 1
PORTSMOUTH HARDWARE & LUMBER, LLC
105 BARTLETT STREET
PORTSMOUTH, NH 03801

SURVEYOR:

AMBIT ENGINEERING, INC.
200 GRIFFIN ROAD - UNIT 3
PORTSMOUTH, NEW HAMPSHIRE 03801

LIST OF PERMITS		
LOCAL	STATUS	DATE
SITE PLAN REVIEW PERMIT	PENDING	
LOT LINE REVISION PERMIT	PENDING	
CONDITIONAL USE PERMIT - SHARED PARKING	PENDING	
CONDITIONAL USE PERMIT - WETLAND BUFFER	PENDING	
STATE		
NHDES - ALTERATION OF TERRAIN PERMIT	PENDING	
NHDES - WETLAND PERMIT	PENDING	
NHDES - SHORELAND PERMIT	PENDING	
NHDES - SEWER CONNECTION PERMIT	PENDING	
FEDERAL		
EPA - NPDES CGP	PENDING	

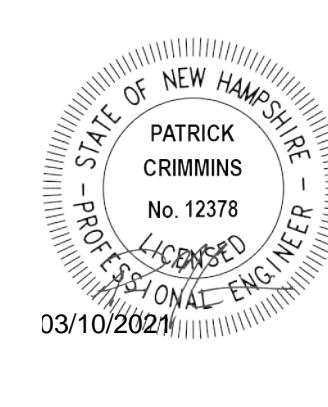
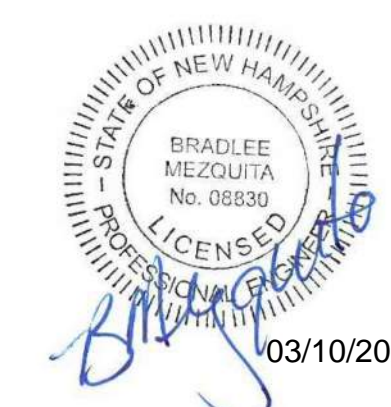

PLANNING BOARD SUBMISSION
COMPLETE SET 38 SHEETS

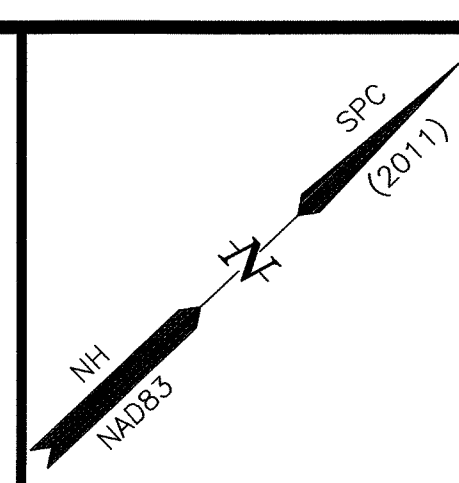
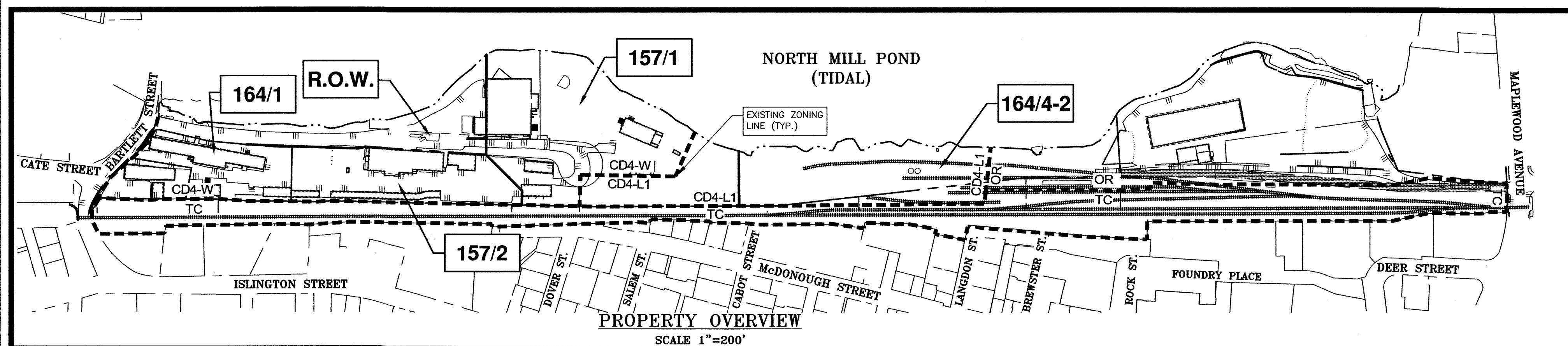

NOTES:

- 1) PARCELS ARE SHOWN ON THE CITY OF PORTSMOUTH ASSESSOR'S MAP 157 LOTS 1 & 2, MAP 164 AS LOTS 1 & 4-2, AND A RIGHT-OF-WAY WITH NO ASSESSOR'S MAP DESIGNATION.
- 2) OWNERS OF RECORD:
 - MAP 157 LOT 1
CLIPPER TRADERS, LLC
105 BARTLETT STREET
PORTSMOUTH, NH 03801
5598/2725 & 5970/1701
 - MAP 157 LOT 2 & MAP 164 LOT 1
PORTSMOUTH LUMBER & HARDWARE, LLC
105 BARTLETT STREET
PORTSMOUTH, NH 03801
5372/2606, 5808/1379, 5540/2567, & 5970/1693
 - MAP 164 LOT 4-2
IRON HORSE PROPERTIES, LLC
105 BARTLETT STREET
PORTSMOUTH, NH 03801
5970/1686 & 6012/2502
- 3) PORTIONS OF THE SUBJECT PARCELS ARE IN A SPECIAL FLOOD HAZARD AREA ZONE AE (EL.9) AS SHOWN ON FIRM PANEL 33015C0259E. EFFECTIVE DATE MAY 17, 2005.
- 4) PARCELS ARE LOCATED IN CHARACTER DISTRICT 4W (CD4-W), CHARACTER DISTRICT 4-L1 (CD4-L1), AND OFFICE RESEARCH (OR) ZONING DISTRICTS.
- 5) THE PURPOSE OF THIS PLAN IS TO SHOW A LOT LINE RELOCATION BETWEEN THE SUBJECT PARCELS IN THE CITY OF PORTSMOUTH.
- 6) VERTICAL DATUM IS MEAN SEA LEVEL NAVD88. BASIS OF VERTICAL DATUM IS REDUNDANT RTN GPS OBSERVATIONS (±0.3').
- 7) HORIZONTAL DATUM AND BASIS OF BEARINGS IS THE NH STATE PLANE COORDINATE SYSTEM NAD 83 (2011). BASIS OF HORIZONTAL DATUM IS REDUNDANT RTN GPS OBSERVATIONS.

EXISTING & PROPOSED LOT AREAS:

MAP 157 LOT 1 EXISTING 61,781± S.F. 1.4183± ACRES	PROPOSED 205,804± S.F. 4.7246± ACRES
MAP 157 LOT 2 EXISTING 102,003 S.F. 2.3417 ACRES	PROPOSED 81,645 S.F. 1.8743 ACRES
MAP 164 LOT 1 EXISTING 51,952 S.F. 1.1927 ACRES	PROPOSED 52,289 S.F. 1.2004 ACRES
MAP 164 LOT 4-2 EXISTING 249,771± S.F. 5.7340± ACRES	PROPOSED 119,519± S.F. 2.7454± ACRES
RIGHT-OF-WAY EXISTING 69,624± S.F. 1.5980± ACRES	PROPOSED 75,792± S.F. 1.7399± ACRES

ZONING DISTRICT DIMENSIONAL REQUIREMENTS:

OFFICE RESEARCH (OR)*:
 *PARCELS ARE SUBJECT TO EXCEPTIONS TO DIMENSIONAL STANDARDS AS OUTLINED IN CITY OF PORTSMOUTH ZONING ORDINANCE SECTION 10.532.10 & 10.532.20, MODIFIED DIMENSIONS LISTED BELOW

MIN. LOT AREA: 2 ACRES
 FRONTAGE: 200 FEET
 SETBACKS:
 FRONT 70 FEET
 SIDE 50 FEET
 REAR 50 FEET
 MAXIMUM STRUCTURE HEIGHT: 70 FEET
 (45 FEET WITHIN 200 FEET OF NORTH MILL POND)
 MAXIMUM STRUCTURE COVERAGE: 50%
 MINIMUM OPEN SPACE: 20%

CHARACTER DISTRICT CD4-L1:

MIN. LOT AREA: 3,000 S.F.
 FRONTAGE: NO REQUIREMENT
 SETBACKS:
 FRONT (MAX.) 15 FEET (PRIMARY)
 FRONT (MAX.) 12 FEET (SECONDARY)
 SIDE 5-20 FEET
 REAR 5 FEET
 MAXIMUM STRUCTURE HEIGHT: 20-30 FEET
 MAXIMUM STRUCTURE COVERAGE: 60%
 MAXIMUM BUILDING FOOTPRINT: 2,500-3,500 S.F.
 MINIMUM OPEN SPACE: 25%
 MAXIMUM BLOCK LENGTH: 80-100 FEET
 BUILDING SEPARATION: 15-30 FEET
 VIEW CORRIDORS: SEE ZONING ORDINANCE

CHARACTER DISTRICT CD4-W:

MIN. LOT AREA: 5,000 S.F.
 FRONTAGE: NO REQUIREMENT
 SETBACKS:
 FRONT (MAX.) 10 FEET (PRIMARY)
 FRONT (MAX.) 15 FEET (SECONDARY)
 SIDE NO REQUIREMENT
 REAR 5 FEET
 MAXIMUM STRUCTURE HEIGHT: 45 FEET
 MAXIMUM STRUCTURE COVERAGE: 60%
 MAXIMUM BUILDING FOOTPRINT: 15,000-20,000 S.F.
 MINIMUM OPEN SPACE: 15%
 MINIMUM FRONT LOT LINE BUILDOUT: 50%

TRANSPORTATION CORRIDOR (TC):
 NO DIMENSIONAL OR USE REQUIREMENTS DEFINED IN ORDINANCE

PLAN REFERENCES:

- 1) LAND IN PORTSMOUTH, N.H. BOSTON AND MAINE RAILROAD TO ERMINIO A.RICCI, SCALE: 1" = 40', APRIL 1960 RCRD 1595/091.
- 2) LAND IN PORTSMOUTH, N.H. BOSTON AND MAINE RAILROAD TO ERMINIO A.RICCI, SCALE: 1" = 40', MAY 1957 RCRD 02612.
- 3) EASEMENT OF LAND IN PORTSMOUTH, N.H. BOSTON AND MAINE RAILROAD TO UNITED STATES OF AMERICA, SCALE 1" = 20', MAY 1957, RCRD 02633.
- 4) LAND IN PORTSMOUTH, N.H. VITO P. MASSARO TO PORT CITY BEVERAGE CO, SCALE 1" = 40', APRIL 1949, RCRD 01448.
- 5) LAND IN PORTSMOUTH, N.H. MARY E. MORAN TO BOSTON AND MAINE RAILROAD, SCALE 1" = 40', MARCH 1920, RCRD 00540.
- 6) PLAN OF LAND OF MARY E. MORAN ON BARTLETT AND ISLINGTON STREETS PORTSMOUTH, N.H., PREPARED BY JOHN W. DURGIN, SCALE 1" = 20', MAY 1920, RCRD 08.
- 7) DRAINAGE EASEMENT GEORGE E. FRISBEE TO THE CITY OF PORTSMOUTH, N.H., PREPARED BY RICHARD P. MILLETTE AND ASSOCIATES, SCALE: 1" = 20', JUNE 1981, RCRD B-10456.
- 8) LAND IN PORTSMOUTH, N.H. BOSTON AND MAINE RAILROAD TO PORTSMOUTH FACTORY BUILDING ASSOCIATION, SCALE 1" = 20' OCTOBER 1923, RCRD 00356.
- 9) NH ELECTRIC CO. PLAN SHOWING AREA RESERVED FOR TRANSFORMER SUBSTATION ON PROPERTY OF CONTINENTAL SHOE CORP. PORTSMOUTH, N.H., SCALE 1" = 30', 11-27-53, RCRD 1303/378.
- 10) BOSTON AND MAINE RAILROAD PLAN TO ACCOMPANY AGREEMENT BETWEEN BOSTON AND MAINE RAILROAD AND PORTSMOUTH RAILROAD COVERING RELOCATION OF TRACKS OF CONCORD AND PORTSMOUTH RAILROAD IN PORTSMOUTH, N.H. OCCASIONED BY CONSTRUCTION OF NEW HIGHWAY AND BRIDGE BY MAINE - NEW HAMPSHIRE INTERSTATE BRIDGE AUTHORITY, SCALE 1" = 500', DECEMBER 1936, RCRD 0934.
- 11) LAND IN PORTSMOUTH, N.H. BOSTON AND MAINE RAILROAD TO CITY CONCRETE CO., INC., SCALE 1" = 80', JANUARY 1955, RCRD 02897.
- 12) LAND IN PORTSMOUTH, N.H. BOSTON AND MAIN RAILROAD TO ALL STATE REALTY CORPORATION, SCALE 1" = 50', FEBRUARY 1961, RCRD 160.
- 13) LAND IN PORTSMOUTH, N.H. BOSTON AND MAINE RAILROAD TO VITO P. MASSARO, SCALE 1" = 40', APRIL 1949, RCRD 01450.
- 14) DRAINAGE EASEMENT STUART AND PAULA BOXER AND ARANSIAN OIL COMPANY TO THE CITY OF PORTSMOUTH, N.H., PREPARED BY RICHARD P. MILLETTE AND ASSOCIATES, SCALE: 1" = 20', JUNE 1981, RCRD B-10455.
- 15) CONDOMINIUM PLAN ISLINGTON PLACE PREPARED FOR ANCHOR BUILDING ASSOCIATES, PREPARED BY KIMBALL CHASE COMPANY, INC., SCALE 1" = 20', 12-10-86, RCRD D-15826.
- 16) PLAN OF LOT 565-581 ISLINGTON STREET PORTSMOUTH, N.H., PREPARED BY JOHN W. DURGIN CIVIL ENGINEERS, SCALE 1" = 10', DECEMBER 1949 REVISED JANUARY 1963, RCRD B28.
- 17) SUBDIVISION OF LAND PORTSMOUTH, N.H. FOR GEORGE AND PAULINE J. FRISBEE, PREPARED BY JOHN W. DURGIN CIVIL ENGINEERS PROFESSIONAL ASSOCIATION, SCALE 1" = 30', DECEMBER 1976, RCRD C-6587.
- 18) RIGHT OF WAY AND TRACK MAP BOSTON AND MAINE R.R. OPERATED BY THE BOSTON AND MAINE R.R. STATION 2966+20 TO STATION 3019+0, SCALE 1" = 100', JUNE 30, 1914, VAL V3NH 55.
- 19) PLAN OF LAND FOR DEER STREET ASSOCIATES DEER AND BRIDGE STREETS AND MAPLEWOOD AVENUE PORTSMOUTH, N.H. COUNTY OF ROCKINGHAM, PREPARED BY AMBIT SURVEY, SCALE: 1" = 30', SEPTEMBER 1993.
- 20) PROPOSED EASEMENTS-- BARTLETT STREET BARTLETT SEWER SEPERATION PROJECT OVER LAND OF PAN AM RAILWAYS PORTSMOUTH, NEW HAMPSHIRE FOR CITY OF PORTSMOUTH, PREPARED BY JAMES VERRA AND ASSOCIATES, INC., SCALE: 1" = 20', DATED 10-01-2007 RCRD D-35477.
- 21) SEWER AND STORM DRAIN EASEMENT PLAN 105 BARTLETT STREET PORTSMOUTH, NEW HAMPSHIRE ASSESSOR'S PARCEL 164-001 & 164-003 EASEMENT OWNER CITY OF PORTSMOUTH, PREPARED BY JAMES VERRA AND ASSOCIATES, INC., SCALE 1" = 20', DATED 01/05/2012, RCRD D-37763.
- 22) EASEMENT PLAN TAX MAP 164 - LOT 4 BOSTON & MAINE CORPORATION TO THE CITY OF PORTSMOUTH OFF BREWSTER STREET CITY OF PORTSMOUTH COUNTY OF ROCKINGHAM STATE OF NEW HAMPSHIRE, PREPARED BY AMBIT ENGINEERING, INC. SCALE: 1" = 30', DATED SEPTEMBER 2012, RCRD D-37720.
- 23) STANDARD BOUNDARY SURVEY TAX MAP 157 - LOTS 7,8,10,11,12,13,14 AND 15 WASHBURN REALTY, INC. AND WASHBURN PLUMBING AND HEATING SUPPLY COMPANY, INC. FOR JAY McSHARRY 449 & 459 ISLINGTON STREET AND 18, 30, 40, & 46 DOVER STREET AND 268 & 280 MCDONOUGH STREET CITY OF PORTSMOUTH, COUNTY OF ROCKINGHAM STATE OF NEW HAMPSHIRE, PREPARED BY AMBIT ENGINEERING, INC., SCALE 1" = 20', DATED JANUARY 2012, NOT RECORDED.
- 24) SITE REDEVELOPMENT NED & BILL PROPERTIES 621-627 ISLINGTON STREET PORTSMOUTH, N.H., PREPARED BY AMBIT ENGINEERING, INC., SCALE 1" = 10', DATED MARCH 2006, NOT RECORDED.
- 25) PLAN OF LAND FOR SAGAMORE ENTERPRISES 653 ISLINGTON STREET COUNTY OF ROCKINGHAM PORTSMOUTH N.H., PREPARED BY RICHARD P. MILLETTE AND ASSOCIATES, SCALE 1" = 10', DATED SEPTEMBER 21, 1988, RCRD D-18742.
- 26) STATION MAP - LANDS BOSTON AND MAINE R.R. OPERATED BY THE BOSTON AND MAINE R.R. STATION 2966+20 TO STATION 3019+0, OFFICE OF VALUATION ENGINEER. BOSTON, MASS, SCALE 1" = 100', JUNE 30, 1914 VAL V3NH SL55.
- 27) STATION MAP - LANDS CONCORD AND PORTSMOUTH R.R. OPERATED BY THE BOSTON AND MAINE R.R. STATION 0+0 TO STATION 33+0, OFFICE OF VALUATION ENGINEER. BOSTON, MASS, SCALE 1" = 100', JUNE 30, 1914 VAL V3NH SL55A.
- 28) SUBDIVISION PLAN TAX MAP 157 - LOTS 1 & 2 TAX MAP 164 - LOTS 1, 2, 3, & 4 OWNER OF RECORD TAX MAP 157, LOT 2 & TAX MAP 164, LOTS 1, 2, & 3: PORTSMOUTH LUMBER AND HARDWARE, LLC OWNER OF RECORD TAX MAP 157, LOT 1: CLIPPER TRADERS, LLC OWNER OF RECORD TAX MAP 164, LOT 4: BOSTON AND MAINE CORPORATION PROPERTY LOCATED AT: 105 BARTLETT STREET, CITY OF PORTSMOUTH, COUNTY OF ROCKINGHAM, STATE OF NEW HAMPSHIRE. PREPARED BY AMBIT ENGINEERING, INC. DATED FEBRUARY 2018, FINAL REVISION DATE DECEMBER 14, 2018. R.C.R.D. PLAN D-41241.
- 29) LAND TRANSFER PLAN TAX MAP 164 - LOT 4 LAND OF: BOSTON AND MAINE CORPORATION TO BE CONVEYED TO: PORTSMOUTH LUMBER AND HARDWARE, LLC & CLIPPER TRADERS, LLC PROPERTY LOCATED AT 105 BARTLETT STREET, CITY OF PORTSMOUTH, COUNTY OF ROCKINGHAM, STATE OF NEW HAMPSHIRE. PREPARED BY AMBIT ENGINEERING, INC. DATED DECEMBER 2018, FINAL REVISION DATE DECEMBER 13, 2018. R.C.R.D. PLAN D-41242.
- 30) WATERLINE EASEMENT PLAN OVER TAX MAP 164 - LOT 4 LAND OF BOSTON AND MAINE CORPORATION FOR BENEFIT OF PORTSMOUTH LUMBER AND HARDWARE, LLC & CLIPPER TRADERS, LLC. OFF MCDONOUGH STREET, CITY OF PORTSMOUTH, COUNTY OF ROCKINGHAM, STATE OF NEW HAMPSHIRE. PREPARED BY AMBIT ENGINEERING, INC. DATED DECEMBER 2018, FINAL REVISION DATE DECEMBER 19, 2018. R.C.R.D. PLAN B-41243.
- 31) LOT LINE RELOCATION PLAN TAX MAP 164 - LOTS 4 & 4-2 OWNERS OF RECORD TAX MAP 164 LOT 4: BOSTON AND MAINE CORPORATION, OWNER OF RECORD TAX MAP 164 LOT 4-2: IRON HORSE PROPERTIES, LLC, PROPERTY LOCATED BETWEEN BARTLETT STREET & MAPLEWOOD AVENUE, CITY OF PORTSMOUTH, COUNTY OF ROCKINGHAM, STATE OF NEW HAMPSHIRE. PREPARED BY AMBIT ENGINEERING, INC. DATED APRIL 2019, FINAL REVISION DATE MAY 30, 2019. R.C.R.D. PLAN D-41570.
- 32) PROPOSED EASEMENT PLAN TAX MAP 164 - LOT 4 OWNER OF RECORD BOSTON AND MAINE CORPORATION TO BENEFIT IRON HORSE PROPERTIES, LLC, PROPERTY LOCATED BETWEEN BARTLETT STREET & MAPLEWOOD AVENUE, CITY OF PORTSMOUTH, COUNTY OF ROCKINGHAM, STATE OF NEW HAMPSHIRE. PREPARED BY AMBIT ENGINEERING, INC. DATED JUNE 2019, FINAL REVISION DATE JUNE 27, 2019. R.C.R.D. PLAN D-41578.

APPROVED BY THE PORTSMOUTH PLANNING BOARD

CHAIRMAN _____ DATE _____

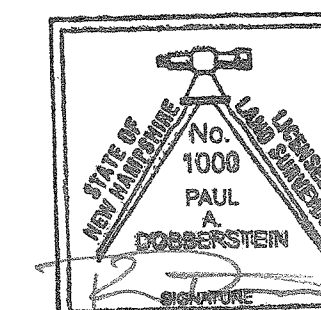

"I CERTIFY THAT THIS PLAN WAS PREPARED UNDER MY DIRECT SUPERVISION, THAT IT IS THE RESULT OF A FIELD SURVEY BY THIS OFFICE AND HAS AN ACCURACY OF THE CLOSED TRAVERSE THAT EXCEEDS THE PRECISION OF 1:15,000."

PAUL A. DOBBERSTEIN, LLS DATE 1/20/2021

**LOT LINE RELOCATION PLAN
 TAX MAP 157 - LOTS 1 & 2
 TAX MAP 164 - LOTS 1 & 4-2**

TAX MAP 157 LOT 1:
CLIPPER TRADERS, LLC
 OWNER OF RECORD

TAX MAP 157 LOT 2 & TAX MAP 164 LOT 1:
PORTSMOUTH LUMBER & HARDWARE, LLC
 OWNER OF RECORD

TAX MAP 164 LOT 4-2:
IRON HORSE PROPERTIES, LLC
 OWNER OF RECORD

RIGHT-OF-WAY (NO TAX MAP DESIGNATION):
**IRON HORSE PROPERTIES, LLC,
 PORTSMOUTH LUMBER & HARDWARE, LLC,
 & CLIPPER TRADERS, LLC**
 PROPERTY LOCATED BETWEEN:
**BARTLETT STREET & MAPLEWOOD AVENUE
 CITY OF PORTSMOUTH
 COUNTY OF ROCKINGHAM
 STATE OF NEW HAMPSHIRE**

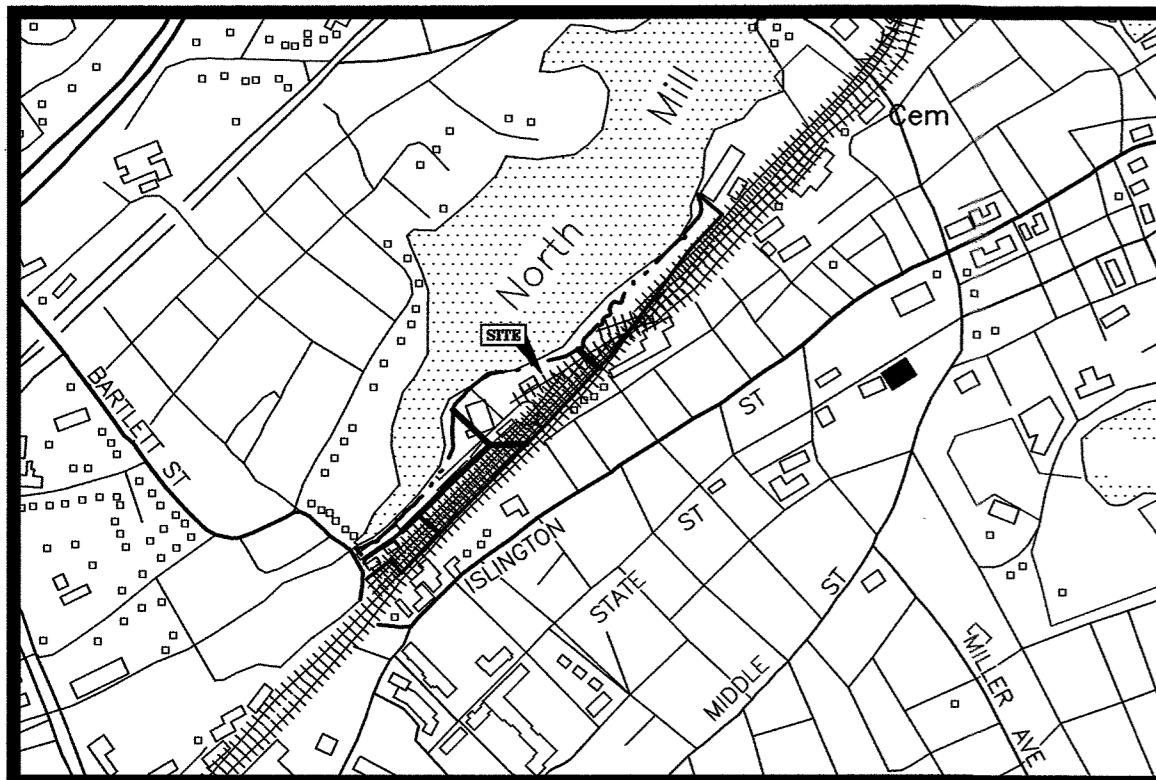

LOCATION MAP SCALE 1"=1,000'

LENGTH TABLE

LINE	BEARING	DISTANCE
L3	N59°39'51"E	2'±

CURVE TABLE

CURVE	RADIUS	ARC LENGTH	CHORD LENGTH	CHORD BEARING	DELTA ANGLE
C5	150.00'	38.24'	38.14'	S39°30'52"W	14°36'24"
C6	200.00'	42.87'	42.79'	S38°21'07"W	12°16'55"
C7	25.00'	31.80'	29.70'	S19°56'09"W	72°52'42"
C8	288.61'	48.94'	48.88'	N21°21'40"W	9°42'56"
C10	288.61'	80.91'	80.65'	N08°28'19"W	16°03'46"

LEGEND:

- N/F NOW OR FORMERLY
- RP RECORD OF PROBATE
- RCRD ROCKINGHAM COUNTY
- REGISTRY OF DEEDS
- (11/21) MAP 11/LOT 21
- IR FND IRON ROD FOUND
- IP FND IRON PIPE FOUND
- IR SET IRON ROD SET
- DH FND DRILL HOLE FOUND
- DH SET DRILL HOLE SET
- △ MN FND MAG NAIL FOUND
- ▲ MN SET MAG NAIL SET
- BND w/DH BOUND WITH DRILL HOLE
- PROPERTY LINE
- - - PROPERTY LINE TO BE ABANDONED
- · - · - PROPOSED PROPERTY LINE
- · - · - MEAN HIGH WATER LINE

N/F
 M & B PROPERTIES, LLC
 54 BARTLETT STREET
 PORTSMOUTH, NH 03801
 5794/996

N/F
 SLATTERY & DUMONT, LLC
 66 OLD CONCORD TURNPIKE #10
 BARRINGTON, NH 03825
 3471/196

NORTH MILL POND (TIDAL)

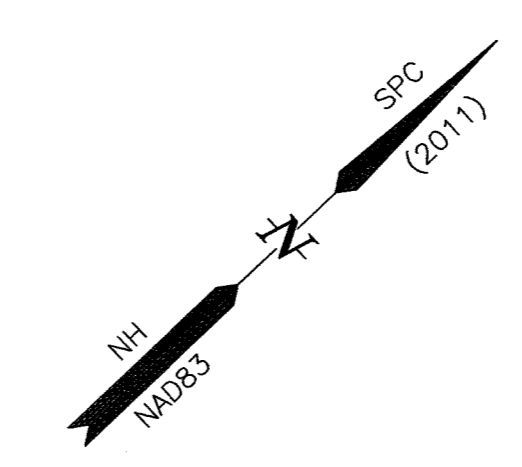
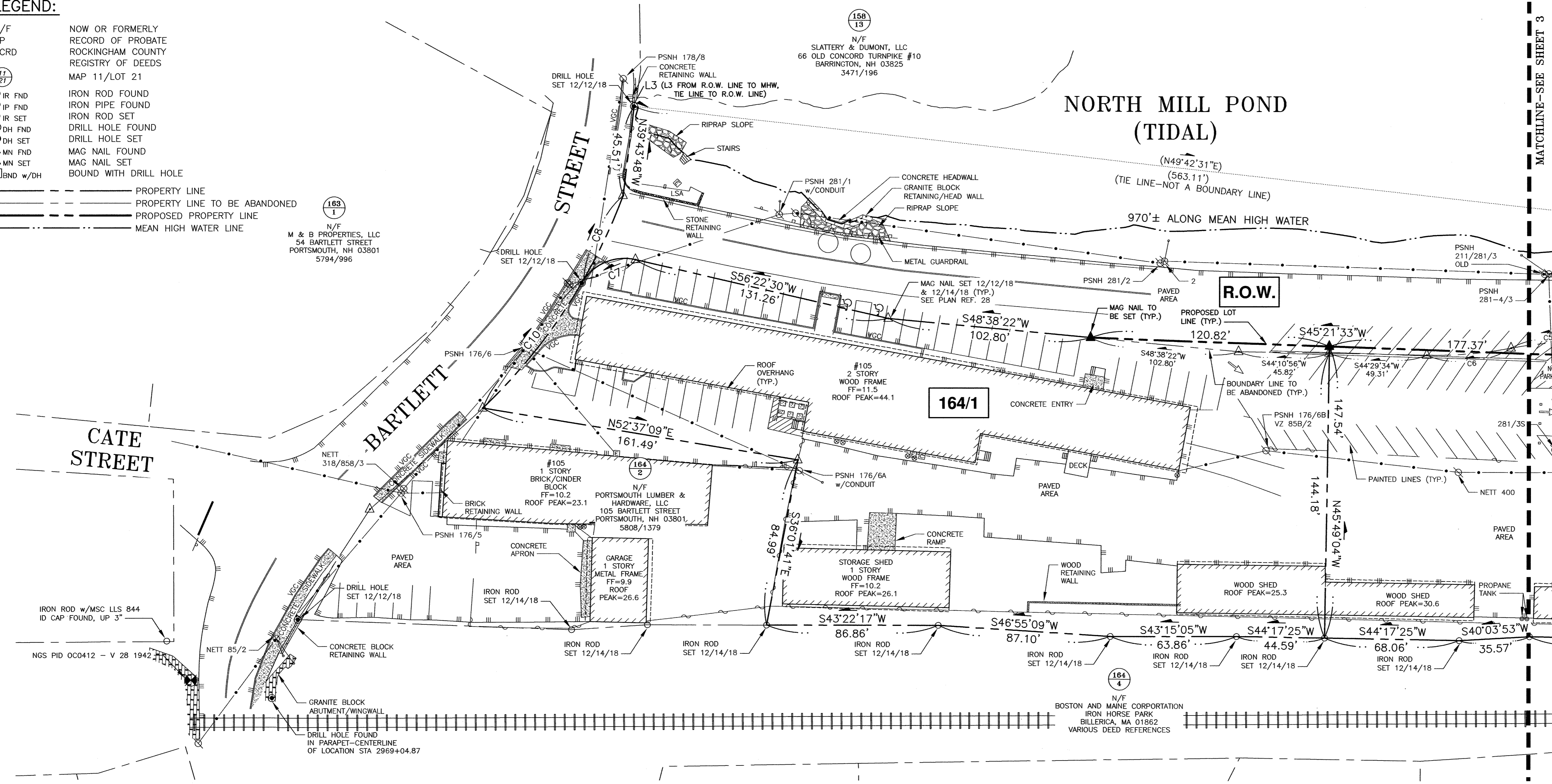

MATCHLINE-SEE SHEET 3

NOTES:

- 1) PARCELS ARE SHOWN ON THE CITY OF PORTSMOUTH ASSESSOR'S MAP 157 LOTS 1 & 2, MAP 164 AS LOTS 1 & 4-2, AND A RIGHT-OF-WAY WITH NO ASSESSOR'S MAP DESIGNATION.
- 2) OWNERS OF RECORD:
 MAP 157 LOT 1
 CLIPPER TRADERS, LLC
 105 BARTLETT STREET
 PORTSMOUTH, NH 03801
 5598/2725 & 5970/1701

 MAP 157 LOT 2 & MAP 164 LOT 1
 PORTSMOUTH LUMBER & HARDWARE, LLC
 105 BARTLETT STREET
 PORTSMOUTH, NH 03801
 5372/2606, 5808/1379, 5540/2567, & 5970/1693

 MAP 164 LOT 4-2
 IRON HORSE PROPERTIES, LLC
 105 BARTLETT STREET
 PORTSMOUTH, NH 03801
 5970/1686 & 6012/2502

 RIGHT-OF-WAY
 CLIPPER TRADERS, LLC, PORTSMOUTH LUMBER & HARDWARE, LLC, & IRON HORSE PROPERTIES, LLC
 5970/1708
- 3) PORTIONS OF THE SUBJECT PARCELS ARE IN A SPECIAL FLOOD HAZARD AREA ZONE AE (EL.9) AS SHOWN ON FIRM PANEL 33015C0259E. EFFECTIVE DATE MAY 17, 2005.
- 4) PARCELS ARE LOCATED IN CHARACTER DISTRICT 4W (CD4-W), CHARACTER DISTRICT 4-L1 (CD4-L1), AND OFFICE RESEARCH (OR) ZONING DISTRICTS.
- 5) THE PURPOSE OF THIS PLAN IS TO SHOW A LOT LINE RELOCATION BETWEEN THE SUBJECT PARCELS IN THE CITY OF PORTSMOUTH.
- 6) VERTICAL DATUM IS MEAN SEA LEVEL NAVD88. BASIS OF VERTICAL DATUM IS REDUNDANT RTN GPS OBSERVATIONS (±0.3').
- 7) HORIZONTAL DATUM AND BASIS OF BEARINGS IS THE NH STATE PLANE COORDINATE SYSTEM NAD 83 (2011). BASIS OF HORIZONTAL DATUM IS REDUNDANT RTN GPS OBSERVATIONS.
- 8) SEE SHEET 1 OF 5 FOR OVERALL PROPERTY VIEW, EXISTING AND PROPOSED LOT AREAS, PLAN REFERENCES, AND DIMENSIONAL REQUIREMENTS.

NO.	DESCRIPTION	DATE
1	REVISE PROPOSED LOT LINE	1/19/21
0	ISSUED FOR COMMENT	6/22/20

LOT LINE RELOCATION PLAN
 TAX MAP 157 - LOTS 1 & 2
 TAX MAP 164 - LOTS 1 & 4-2

TAX MAP 157 LOT 1:
CLIPPER TRADERS, LLC
 OWNER OF RECORD

 TAX MAP 157 LOT 2 & TAX MAP 164 LOT 1:
PORTSMOUTH LUMBER & HARDWARE, LLC
 OWNER OF RECORD

 TAX MAP 164 LOT 4-2:
IRON HORSE PROPERTIES, LLC
 OWNER OF RECORD

RIGHT-OF-WAY (NO TAX MAP DESIGNATION):
IRON HORSE PROPERTIES, LLC,
PORTSMOUTH LUMBER & HARDWARE, LLC,
& CLIPPER TRADERS, LLC
 PROPERTY LOCATED BETWEEN:
BARTLETT STREET & MAPLEWOOD AVENUE
 CITY OF PORTSMOUTH
 COUNTY OF ROCKINGHAM
 STATE OF NEW HAMPSHIRE

APPROVED BY THE PORTSMOUTH PLANNING BOARD

CHAIRMAN _____ DATE _____

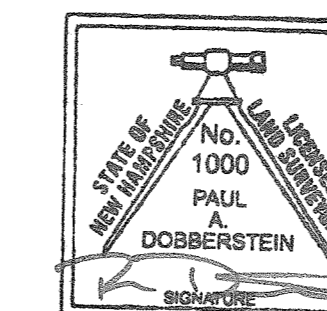
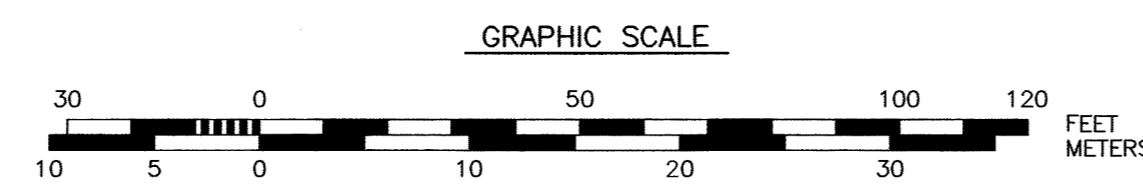

"I CERTIFY THAT THIS PLAN WAS PREPARED UNDER MY DIRECT SUPERVISION, THAT IT IS THE RESULT OF A FIELD SURVEY BY THIS OFFICE AND HAS AN ACCURACY OF THE CLOSED TRAVERSE THAT EXCEEDS THE PRECISION OF 1:15,000."

PAUL A DOBBERSTEIN, LLS DATE 1/20/2021

LEGEND:

- N/F NOW OR FORMERLY
- RP RECORD OF PROBATE
- RCRD ROCKINGHAM COUNTY
- REGISTRY OF DEEDS
- MAP 11/LOT 21
- IR FND IRON ROD FOUND
- IP FND IRON PIPE FOUND
- IR SET IRON ROD SET
- DH FND DRILL HOLE FOUND
- DH SET DRILL HOLE SET
- MN SET MAG NAIL SET
- BND w/DH BOUND WITH DRILL HOLE
- PROPERTY LINE
- PROPERTY LINE TO BE ABANDONED
- PROPOSED PROPERTY LINE
- MEAN HIGH WATER LINE

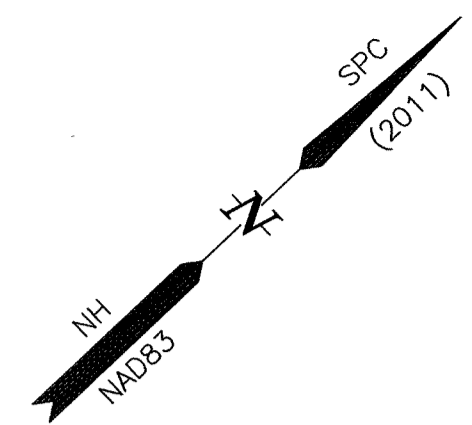

NORTH MILL POND (TIDAL)

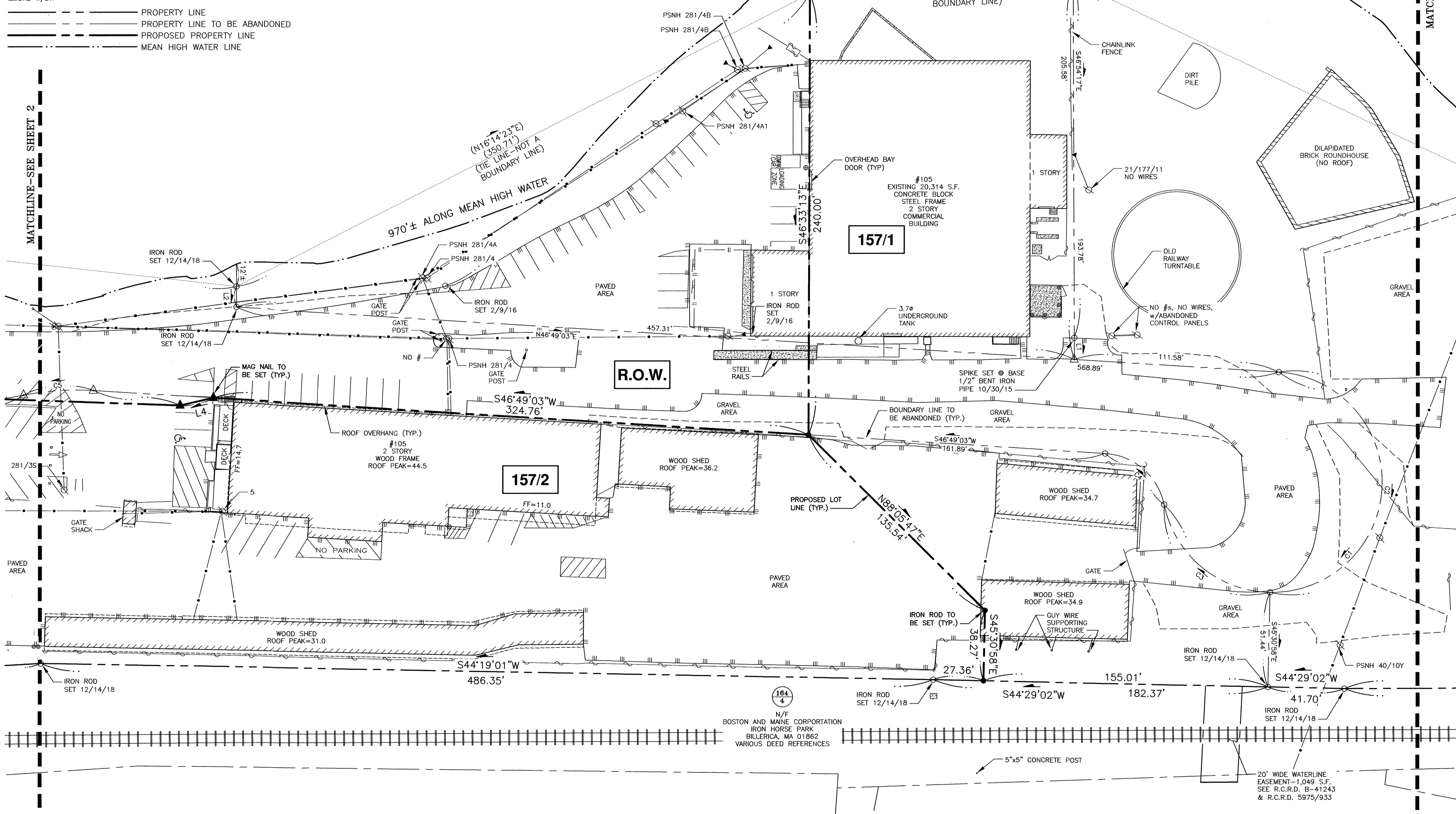

LENGTH TABLE

LINE	BEARING	DISTANCE
L1	S46°54'17"E	11.80'
L2	S46°49'43"E	11.20'
L3	N59°39'51"E	2'±
L4	S30°20'37"W	18.60'

CURVE TABLE

CURVE	RADIUS	ARC LENGTH	CHORD LENGTH	CHORD BEARING	DELTA ANGLE
C1	60.00'	266.77'	95.37'	S05°48'40"E	254°44'33"
C2	60.00'	185.84'	119.97'	S44°26'53"E	177°28'07"
C3	60.00'	80.92'	74.93'	S82°55'23"W	77°16'26"

GRAPHIC SCALE

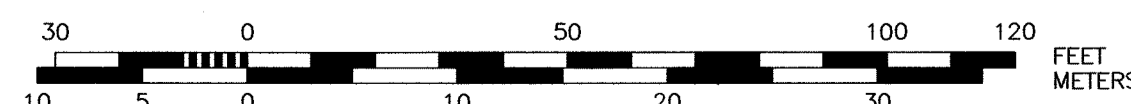

APPROVED BY THE PORTSMOUTH PLANNING BOARD

CHAIRMAN _____

DATE _____

AMBIT ENGINEERING, INC.
 Civil Engineers & Land Surveyors
 200 Griffin Road - Unit 3
 Portsmouth, N.H. 03801-7114
 Tel (603) 430-9282
 Fax (603) 436-2815

NOTES:

- PARCELS ARE SHOWN ON THE CITY OF PORTSMOUTH ASSESSOR'S MAP 157 LOTS 1 & 2, MAP 164 AS LOTS 1 & 4-2, AND A RIGHT-OF-WAY WITH NO ASSESSOR'S MAP DESIGNATION.
- OWNERS OF RECORD:
 MAP 157 LOT 1
 CLIPPER TRADERS, LLC
 105 BARTLETT STREET
 PORTSMOUTH, NH 03801
 5598/2725 & 5970/1701

 MAP 157 LOT 2 & MAP 164 LOT 1
 PORTSMOUTH LUMBER & HARDWARE, LLC
 105 BARTLETT STREET
 PORTSMOUTH, NH 03801
 5372/2606, 5808/1379, 5540/2567, & 5970/1693

 MAP 164 LOT 4-2
 IRON HORSE PROPERTIES, LLC
 105 BARTLETT STREET
 PORTSMOUTH, NH 03801
 5970/1686 & 6012/2502

 RIGHT-OF-WAY
 CLIPPER TRADERS, LLC, PORTSMOUTH LUMBER & HARDWARE, LLC, & IRON HORSE PROPERTIES, LLC
 5970/1708
- PORTIONS OF THE SUBJECT PARCELS ARE IN A SPECIAL FLOOD HAZARD AREA ZONE AE (EL.9) AS SHOWN ON FIRM PANEL 33015C0259E. EFFECTIVE DATE MAY 17, 2005.
- PARCELS ARE LOCATED IN CHARACTER DISTRICT 4W (CD4-W), CHARACTER DISTRICT 4-L1 (CD4-L1), AND OFFICE RESEARCH (OR) ZONING DISTRICTS.
- THE PURPOSE OF THIS PLAN IS TO SHOW A LOT LINE RELOCATION BETWEEN THE SUBJECT PARCELS IN THE CITY OF PORTSMOUTH.
- VERTICAL DATUM IS MEAN SEA LEVEL NAVD88. BASIS OF VERTICAL DATUM IS REDUNDANT RTN GPS OBSERVATIONS (±0.3").
- HORIZONTAL DATUM AND BASIS OF BEARINGS IS THE NH STATE PLANE COORDINATE SYSTEM NAD 83 (2011). BASIS OF HORIZONTAL DATUM IS REDUNDANT RTN GPS OBSERVATIONS.
- SEE SHEET 1 OF 5 FOR OVERALL PROPERTY VIEW, EXISTING AND PROPOSED LOT AREAS, PLAN REFERENCES, AND DIMENSIONAL REQUIREMENTS.

NO.	DESCRIPTION	DATE
1	REVISE PROPOSED LOT LINE	1/19/21
0	ISSUED FOR COMMENT	6/22/20

**LOT LINE RELOCATION PLAN
 TAX MAP 157 - LOTS 1 & 2
 TAX MAP 164 - LOTS 1 & 4-2**

TAX MAP 157 LOT 1:
CLIPPER TRADERS, LLC
 OWNER OF RECORD
 TAX MAP 157 LOT 2 & TAX MAP 164 LOT 1:
PORTSMOUTH LUMBER & HARDWARE, LLC
 OWNER OF RECORD
 TAX MAP 164 LOT 4-2:
IRON HORSE PROPERTIES, LLC
 OWNER OF RECORD
 RIGHT-OF-WAY (NO TAX MAP DESIGNATION):
**IRON HORSE PROPERTIES, LLC,
 PORTSMOUTH LUMBER & HARDWARE, LLC,
 & CLIPPER TRADERS, LLC**
 PROPERTY LOCATED BETWEEN:
BARTLETT STREET & MAPLEWOOD AVENUE
 CITY OF PORTSMOUTH
 COUNTY OF ROCKINGHAM
 STATE OF NEW HAMPSHIRE

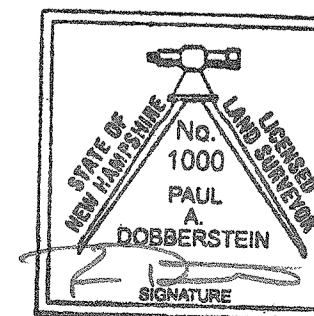

"I CERTIFY THAT THIS PLAN WAS PREPARED UNDER MY DIRECT SUPERVISION, THAT IT IS THE RESULT OF A FIELD SURVEY BY THIS OFFICE AND HAS AN ACCURACY OF THE CLOSED TRAVERSE THAT EXCEEDS THE PRECISION OF 1:15,000."

PAUL A DOBBERSTEIN, LLS
 DATE 1/20/2021

LEGEND:

- | | |
|------------|--|
| N/F | NOW OR FORMERLY |
| RP | RECORD OF PROBATE |
| RCRD | ROCKINGHAM COUNTY
REGISTRY OF DEEDS |
| (11/21) | MAP 11/LOT 21 |
| ○ IR FND | IRON ROD FOUND |
| ○ IP FND | IRON PIPE FOUND |
| ● IR SET | IRON ROD SET |
| ● DH FND | DRILL HOLE FOUND |
| ● DH SET | DRILL HOLE SET |
| △ MN FND | MAG NAIL FOUND |
| △ MN SET | MAG NAIL SET |
| ▣ BND w/DH | BOUND WITH DRILL HOLE |
| --- | PROPERTY LINE |
| - - - - | PROPERTY LINE TO BE ABANDONED |
| - · - · - | PROPOSED PROPERTY LINE |
| --- | MEAN HIGH WATER LINE |

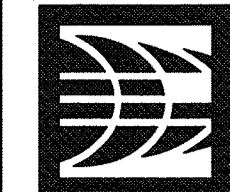
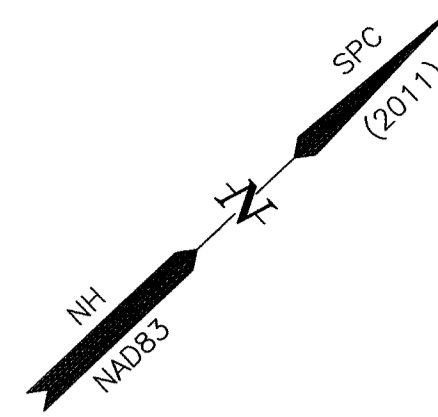

AMBIT ENGINEERING, INC.
Civil Engineers & Land Surveyors
200 Griffin Road - Unit 3
Portsmouth, N.H. 03801-7114
Tel (603) 430-9282
Fax (603) 436-2915

NOTES:

- PARCELS ARE SHOWN ON THE CITY OF PORTSMOUTH ASSESSOR'S MAP 157 LOTS 1 & 2, MAP 164 AS LOTS 1 & 4-2, AND A RIGHT-OF-WAY WITH NO ASSESSOR'S MAP DESIGNATION.
- OWNERS OF RECORD:
 MAP 157 LOT 1
 CLIPPER TRADERS, LLC
 105 BARTLETT STREET
 PORTSMOUTH, NH 03801
 5598/2725 & 5970/1701

 MAP 157 LOT 2 & MAP 164 LOT 1
 PORTSMOUTH LUMBER & HARDWARE, LLC
 105 BARTLETT STREET
 PORTSMOUTH, NH 03801
 5372/2606, 5808/1379, 5540/2567, & 5970/1693

 MAP 164 LOT 4-2
 IRON HORSE PROPERTIES, LLC
 105 BARTLETT STREET
 PORTSMOUTH, NH 03801
 5970/1686 & 6012/2502

 RIGHT-OF-WAY
 CLIPPER TRADERS, LLC, PORTSMOUTH LUMBER & HARDWARE, LLC, & IRON HORSE PROPERTIES, LLC
 5970/1708
- PORTIONS OF THE SUBJECT PARCELS ARE IN A SPECIAL FLOOD HAZARD AREA ZONE AE (EL.9) AS SHOWN ON FIRM PANEL 33015C0259E. EFFECTIVE DATE MAY 17, 2005.
- PARCELS ARE LOCATED IN CHARACTER DISTRICT 4W (CD4-W), CHARACTER DISTRICT 4-L1 (CD4-L1), AND OFFICE RESEARCH (OR) ZONING DISTRICTS.
- THE PURPOSE OF THIS PLAN IS TO SHOW A LOT LINE RELOCATION BETWEEN THE SUBJECT PARCELS IN THE CITY OF PORTSMOUTH.
- VERTICAL DATUM IS MEAN SEA LEVEL NAVD88. BASIS OF VERTICAL DATUM IS REDUNDANT RTN GPS OBSERVATIONS (±0.3').
- HORIZONTAL DATUM AND BASIS OF BEARINGS IS THE NH STATE PLANE COORDINATE SYSTEM NAD 83 (2011). BASIS OF HORIZONTAL DATUM IS REDUNDANT RTN GPS OBSERVATIONS.
- SEE SHEET 1 OF 5 FOR OVERALL PROPERTY VIEW, EXISTING AND PROPOSED LOT AREAS, PLAN REFERENCES, AND DIMENSIONAL REQUIREMENTS.

NO.	DESCRIPTION	DATE
1	REVISE PROPOSED LOT LINE	1/19/21
0	ISSUED FOR COMMENT	6/22/20

LOT LINE RELOCATION PLAN
TAX MAP 157 - LOTS 1 & 2
TAX MAP 164 - LOTS 1 & 4-2
 TAX MAP 157 LOT 1:
CLIPPER TRADERS, LLC
 OWNER OF RECORD
 TAX MAP 157 LOT 2 & TAX MAP 164 LOT 1:
PORTSMOUTH LUMBER & HARDWARE, LLC
 OWNER OF RECORD
 TAX MAP 164 LOT 4-2:
IRON HORSE PROPERTIES, LLC
 OWNER OF RECORD
 RIGHT-OF-WAY (NO TAX MAP DESIGNATION):
IRON HORSE PROPERTIES, LLC,
PORTSMOUTH LUMBER & HARDWARE, LLC,
& CLIPPER TRADERS, LLC
 PROPERTY LOCATED BETWEEN:
BARTLETT STREET & MAPLEWOOD AVENUE
 CITY OF PORTSMOUTH
 COUNTY OF ROCKINGHAM
 STATE OF NEW HAMPSHIRE

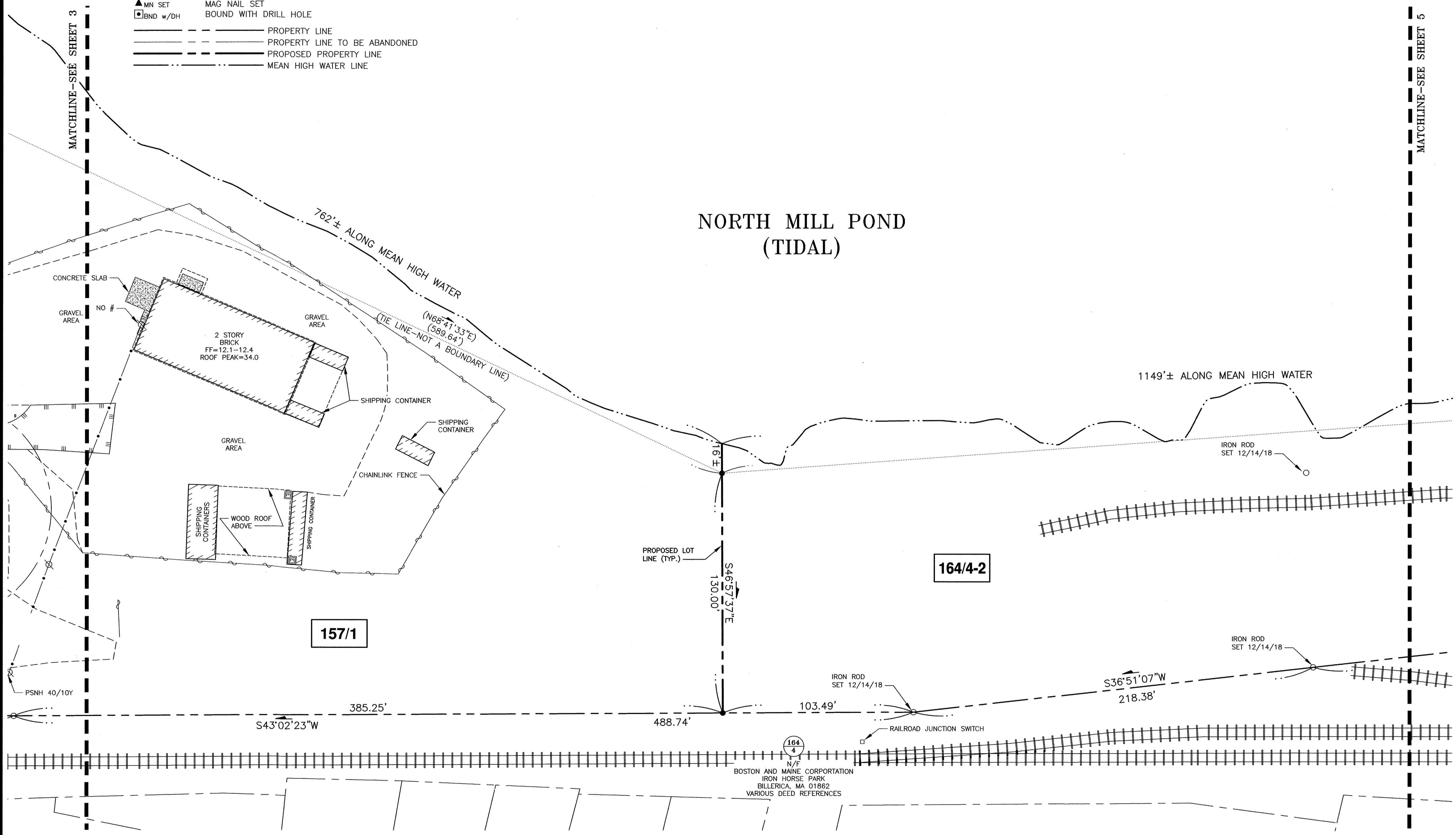

APPROVED BY THE PORTSMOUTH PLANNING BOARD

CHAIRMAN _____ DATE _____

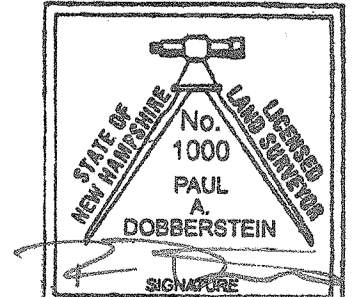
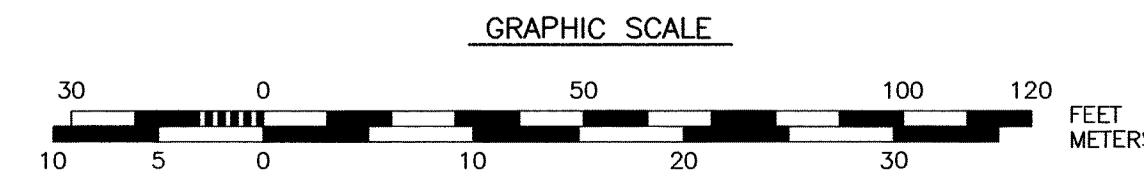

"I CERTIFY THAT THIS PLAN WAS PREPARED UNDER MY DIRECT SUPERVISION, THAT IT IS THE RESULT OF A FIELD SURVEY BY THIS OFFICE AND HAS AN ACCURACY OF THE CLOSED TRAVERSE THAT EXCEEDS THE PRECISION OF 1:15,000."
 PAUL A. DOBBERSTEIN, LLS
 DATE 1/20/2021

NOTES:

- 1) PARCELS ARE SHOWN ON THE CITY OF PORTSMOUTH ASSESSOR'S MAP 157 LOTS 1 & 2, MAP 164 AS LOTS 1 & 4-2, AND A RIGHT-OF-WAY WITH NO ASSESSOR'S MAP DESIGNATION.
- 2) OWNERS OF RECORD:
 MAP 157 LOT 1
 CLIPPER TRADERS, LLC
 105 BARTLETT STREET
 PORTSMOUTH, NH 03801
 5598/2725 & 5970/1701

 MAP 157 LOT 2 & MAP 164 LOT 1
 PORTSMOUTH LUMBER & HARDWARE, LLC
 105 BARTLETT STREET
 PORTSMOUTH, NH 03801
 5372/2606, 5808/1379, 5540/2567, & 5970/1693

 MAP 164 LOT 4-2
 IRON HORSE PROPERTIES, LLC
 105 BARTLETT STREET
 PORTSMOUTH, NH 03801
 5970/1686 & 6012/2502

 RIGHT-OF-WAY
 CLIPPER TRADERS, LLC, PORTSMOUTH LUMBER & HARDWARE, LLC, & IRON HORSE PROPERTIES, LLC
 5970/1708
- 3) PORTIONS OF THE SUBJECT PARCELS ARE IN A SPECIAL FLOOD HAZARD AREA ZONE AE (EL.9) AS SHOWN ON FIRM PANEL 33015C0259E. EFFECTIVE DATE MAY 17, 2005.
- 4) PARCELS ARE LOCATED IN CHARACTER DISTRICT 4W (CD4-W), CHARACTER DISTRICT 4-L1 (CD4-L1), AND OFFICE RESEARCH (OR) ZONING DISTRICTS.
- 5) THE PURPOSE OF THIS PLAN IS TO SHOW A LOT LINE RELOCATION BETWEEN THE SUBJECT PARCELS IN THE CITY OF PORTSMOUTH.
- 6) VERTICAL DATUM IS MEAN SEA LEVEL NAVD88. BASIS OF VERTICAL DATUM IS REDUNDANT RTN GPS OBSERVATIONS (±0.3").
- 7) HORIZONTAL DATUM AND BASIS OF BEARINGS IS THE NH STATE PLANE COORDINATE SYSTEM NAD 83 (2011). BASIS OF HORIZONTAL DATUM IS REDUNDANT RTN GPS OBSERVATIONS.
- 8) SEE SHEET 1 OF 5 FOR OVERALL PROPERTY VIEW, EXISTING AND PROPOSED LOT AREAS, PLAN REFERENCES, AND DIMENSIONAL REQUIREMENTS.

NO.	DESCRIPTION	DATE
1	REVISE PROPOSED LOT LINE	1/19/21
0	ISSUED FOR COMMENT	6/22/20
REVISIONS		

LOT LINE RELOCATION PLAN
TAX MAP 157 - LOTS 1 & 2
TAX MAP 164 - LOTS 1 & 4-2
 TAX MAP 157 LOT 1:
CLIPPER TRADERS, LLC
 OWNER OF RECORD
 TAX MAP 157 LOT 2 & TAX MAP 164 LOT 1:
PORTSMOUTH LUMBER & HARDWARE, LLC
 OWNER OF RECORD
 TAX MAP 164 LOT 4-2:
IRON HORSE PROPERTIES, LLC
 OWNER OF RECORD
 RIGHT-OF-WAY (NO TAX MAP DESIGNATION):
IRON HORSE PROPERTIES, LLC,
PORTSMOUTH LUMBER & HARDWARE, LLC,
& CLIPPER TRADERS, LLC
 PROPERTY LOCATED BETWEEN:
BARTLETT STREET & MAPLEWOOD AVENUE
CITY OF PORTSMOUTH
COUNTY OF ROCKINGHAM
STATE OF NEW HAMPSHIRE

LEGEND:

- | | | | |
|------------|-----------------------|-----|-------------------------------|
| N/F | NOW OR FORMERLY | --- | PROPERTY LINE |
| RP | RECORD OF PROBATE | --- | PROPERTY LINE TO BE ABANDONED |
| RCD | ROCKINGHAM COUNTY | --- | PROPOSED PROPERTY LINE |
| | REGISTRY OF DEEDS | --- | MEAN HIGH WATER LINE |
| (11/21) | MAP 11/LOT 21 | | |
| ○ IR FND | IRON ROD FOUND | | |
| ○ IP FND | IRON PIPE FOUND | | |
| ● IR SET | IRON ROD SET | | |
| ⊙ DH FND | DRILL HOLE FOUND | | |
| ⊙ DH SET | DRILL HOLE SET | | |
| ▲ MN FND | MAG NAIL FOUND | | |
| ▲ MN SET | MAG NAIL SET | | |
| □ BND w/DH | BOUND WITH DRILL HOLE | | |

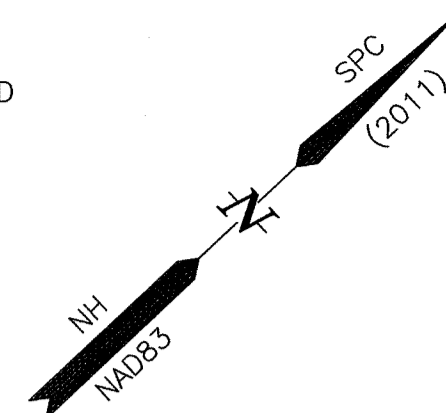

NORTH MILL POND (TIDAL)

LENGTH TABLE

LINE	BEARING	DISTANCE
L5	S46°57'07"E	20.00'

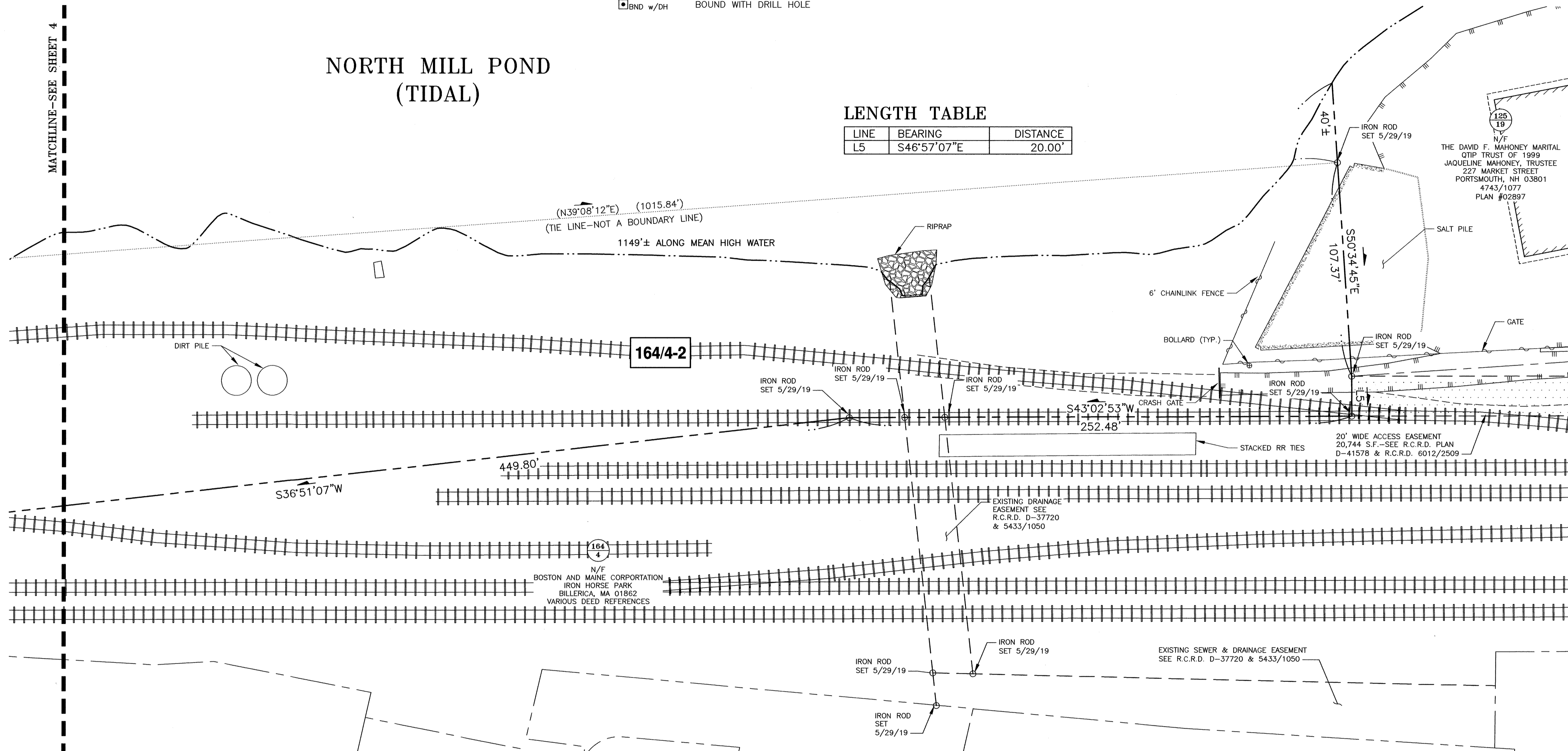

APPROVED BY THE PORTSMOUTH PLANNING BOARD

CHAIRMAN _____ DATE _____

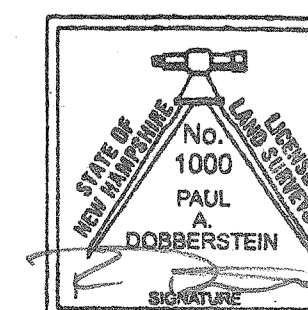
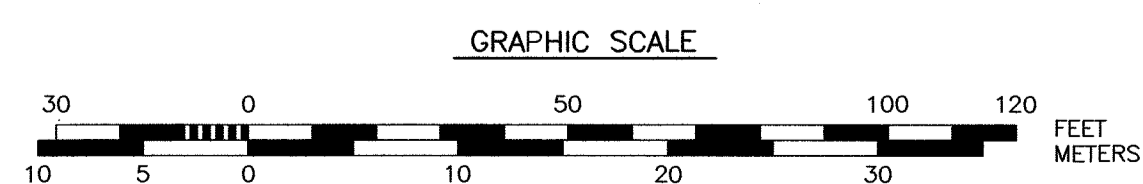

I CERTIFY THAT THIS PLAN WAS PREPARED UNDER MY DIRECT SUPERVISION, THAT IT IS THE RESULT OF A FIELD SURVEY BY THIS OFFICE AND HAS AN ACCURACY OF THE CLOSED TRAVERSE THAT EXCEEDS THE PRECISION OF 1:15,000."

PAUL A. DOBBERSTEIN, LLS DATE 1/20/2021

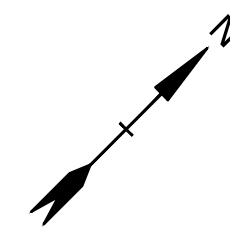

LEGEND

- BUILDING
- BUILDING OVERHANG
- BUILDING HATCH/TEXT
- CURB
- EDGE OF PAVEMENT
- RETAINING WALL
- STONE WALL
- CHAIN LINK FENCE
- FENCE LINE
- TREELINE
- PAVEMENT MARKING
- TRAFFIC SIGN
- MAJOR CONTOURS
- MINOR CONTOURS
- STORM DRAIN LINE
- SANITARY SEWER LINE
- WATER LINE
- UNDERGROUND ELECTRIC LINE
- OVERHEAD ELECTRIC LINE
- UNDERGROUND GAS LINE
- DRAIN MANHOLE
- CATCH BASIN
- SEWER MANHOLE
- HYDRANT
- WATER GATE VALVE
- UTILITY POLE
- TELEPHONE STRUCTURE
- GAS GATE VALVE
- BOLLARD
- GAS SHUTOFF
- WATER SHUTOFF

- EXISTING CONDITIONS PLAN NOTES:**
1. EXISTING CONDITIONS ARE BASED ON A FIELD SURVEY BY AMBIT ENGINEERING, INC., DATED 3/5/2018.
 2. WETLAND DELINEATION BY STEVEN D. RIKER, CWS, ON 8/8/2017, AND FIELD LOCATED BY AMBIT ENGINEERING, INC. ON 8/9/2017
 3. FLOOD HAZARD ZONES: "AE ELEV. 9" (SPECIAL FLOOD HAZARD AREA) AND "X" (NOT A SPECIAL FLOOD HAZARD AREA), PER FIRM MAP #33015C0259E, DATED 5/17/05.
- REFERENCE PLANS:**
1. "PROPOSED SUBDIVISION PLANS, CLIPPER TRADERS, LLC" PREPARED BY AMBIT ENGINEERING, INC., DATED DECEMBER 14, 2018.

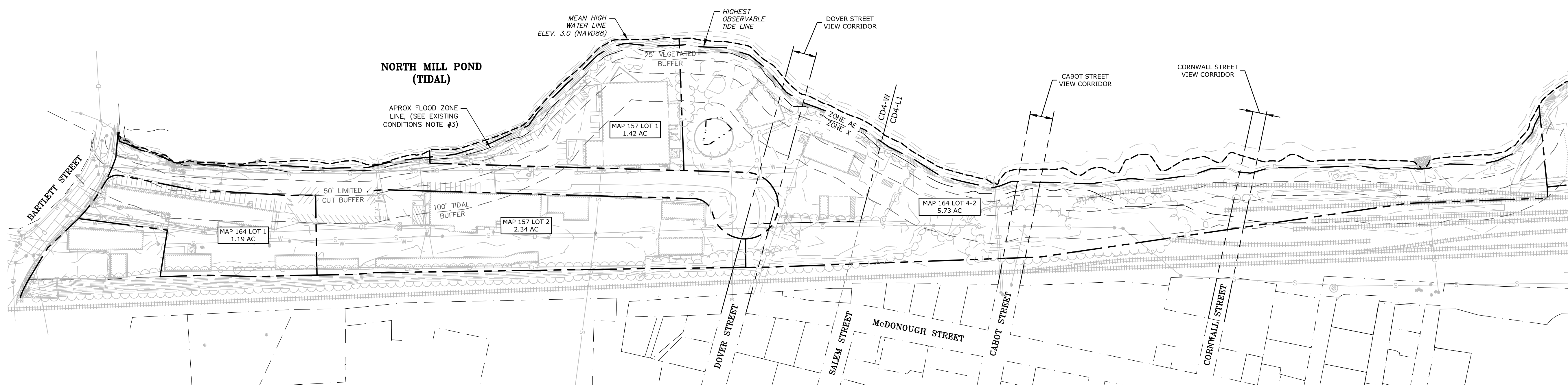
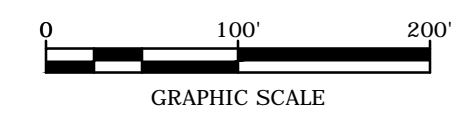

Proposed Multi-Family Development

Iron Horse Properties, LLC

105 Bartlett Street
Portsmouth,
New Hampshire

MARK	DATE	DESCRIPTION
I	3/10/2021	PB Submission
H	1/20/2021	TAC Resubmission
G	11/18/2020	TAC Resubmission
F	10/28/2020	Wetland CUP Resubmission
E	5/20/2020	TAC Resubmission
D	4/29/2020	Wetland CUP Submission
C	4/20/2020	TAC Submission
B	2/6/2020	Design Review Submission
A	1/2/2020	ZBA Submission

PROJECT NO:	C-0960-006
DATE:	April 20, 2020
FILE:	C-0960-006_C-SITE.DWG
DRAWN BY:	NAH
CHECKED:	PMC
APPROVED:	BML

OVERALL EXISTING CONDITIONS PLAN

SCALE: AS SHOWN

Last Saved: 3/10/2021
 Plotted On: Mar 10, 2021 1:58:48pm By: N.Hansens
 Tighe & Bond, F.C. Collins, C. Calhoun, C. 0960-006 105 Bartlett Street Drawings, Figures AutoCAD Sheet C-0960-006 C-SITE.dwg

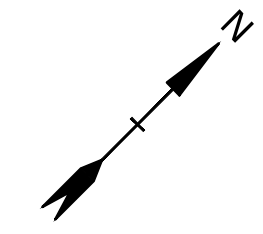

DEMOLITION NOTES:

1. THE LOCATIONS OF UNDERGROUND UTILITIES ARE APPROXIMATE AND THE LOCATIONS ARE NOT GUARANTEED BY THE OWNER OR THE ENGINEER. IT IS THE CONTRACTOR'S RESPONSIBILITY TO LOCATE ALL UTILITIES, ANTICIPATE CONFLICTS, REPAIR EXISTING UTILITIES AND RELOCATE EXISTING UTILITIES REQUIRED TO COMPLETE THE WORK.
2. THE CONTRACTOR SHALL VERIFY LOCATION OF ALL EXISTING UTILITIES. CALL DIG SAFE AT LEAST 72 HOURS PRIOR TO THE COMMENCEMENT OF ANY DEMOLITION/CONSTRUCTION ACTIVITIES.
3. ALL MATERIALS SCHEDULED TO BE REMOVED SHALL BECOME THE PROPERTY OF THE CONTRACTOR UNLESS OTHERWISE SPECIFIED. THE CONTRACTOR SHALL DISPOSE OF ALL MATERIALS OFF-SITE IN ACCORDANCE WITH ALL FEDERAL, STATE, AND LOCAL REGULATIONS, ORDINANCES AND CODES.
4. COORDINATE REMOVAL, RELOCATION, DISPOSAL OR SALVAGE OF UTILITIES WITH THE OWNER AND APPROPRIATE UTILITY COMPANY.
5. ANY EXISTING WORK OR PROPERTY DAMAGED OR DISRUPTED BY CONSTRUCTION/ DEMOLITION ACTIVITIES SHALL BE REPLACED OR REPAIRED TO MATCH ORIGINAL EXISTING CONDITIONS BY THE CONTRACTOR AT NO ADDITIONAL COST TO THE OWNER.
6. SAW CUT AND REMOVE PAVEMENT ONE (1) FOOT OFF PROPOSED EDGE OF PAVEMENT OR EXISTING CURB LINE IN ALL AREAS WHERE PAVEMENT TO BE REMOVED ABUTS EXISTING PAVEMENT OR CONCRETE TO REMAIN.
7. IT IS THE CONTRACTOR'S RESPONSIBILITY TO FAMILIARIZE THEMSELVES WITH THE CONDITIONS OF ALL OF THE PERMIT APPROVALS.
8. THE CONTRACTOR SHALL OBTAIN AND PAY FOR ADDITIONAL PERMITS, NOTICES AND FEES NECESSARY TO COMPLETE THE WORK AND ARRANGE FOR AND PAY FOR NECESSARY INSPECTIONS AND APPROVALS FROM THE AUTHORITIES HAVING JURISDICTION.
9. THE CONTRACTOR SHALL BE RESPONSIBLE FOR ALL DEMOLITION AND OFF-SITE DISPOSAL OF MATERIALS REQUIRED TO COMPLETE THE WORK, EXCEPT FOR WORK NOTED TO BE COMPLETED BY OTHERS.
10. UTILITIES SHALL BE TERMINATED AT THE MAIN LINE PER UTILITY COMPANY STANDARDS. THE CONTRACTOR SHALL REMOVE ALL ABANDONED UTILITIES LOCATED WITHIN THE LIMITS OF WORK.
11. CONTRACTOR SHALL VERIFY ORIGIN OF ALL DRAINS AND UTILITIES PRIOR TO REMOVAL/TERMINATION TO DETERMINE IF DRAINS OR UTILITY IS ACTIVE, AND SERVICES ANY ON OR OFF-SITE STRUCTURE TO REMAIN. THE CONTRACTOR SHALL NOTIFY ENGINEER IMMEDIATELY OF ANY SUCH UTILITY FOUND AND SHALL MAINTAIN THESE UTILITIES UNTIL PERMANENT SOLUTION IS IN PLACE.
12. PAVEMENT REMOVAL LIMITS ARE SHOWN FOR CONTRACTOR'S CONVENIENCE. ADDITIONAL PAVEMENT REMOVAL MAY BE REQUIRED DEPENDING ON THE CONTRACTOR'S OPERATION. CONTRACTOR TO VERIFY FULL LIMITS OF PAVEMENT REMOVAL PRIOR TO BID.
13. ALL ITEMS WITHIN THE LIMIT OF WORK ARE TO REMAIN UNLESS SPECIFICALLY IDENTIFIED TO BE REMOVED OR OTHERWISE ALTERED BY THE CONTRACTOR. ITEMS TO BE REMOVED INCLUDE, BUT ARE NOT LIMITED TO: CONCRETE, PAVEMENT, MANHOLES, CATCH BASINS, UNDERGROUND PIPING & UTILITIES, POLES, STAIRS, STRUCTURES, FENCES, RAMPS, BUILDING FOUNDATIONS, TREES, AND LANDSCAPING. THE CONTRACTOR SHALL CONFIRM WITH THE ENGINEER IF THE TREATMENT OF CERTAIN ITEMS IS UNCLEAR.
14. COORDINATE ALL WORK WITHIN THE PUBLIC RIGHT OF WAYS WITH THE CITY OF PORTSMOUTH.
15. REMOVE TREES AND BRUSH AS REQUIRED FOR COMPLETION OF WORK. CONTRACTOR SHALL GRUB AND REMOVE ALL STUMPS WITHIN LIMITS OF WORK AND DISPOSE OF OFF SITE IN ACCORDANCE WITH FEDERAL, STATE, AND LOCAL LAWS AND REGULATIONS.
16. CONTRACTOR SHALL PROTECT ALL PROPERTY MONUMENTATION THROUGHOUT DEMOLITION AND CONSTRUCTION OPERATIONS. SHOULD ANY MONUMENTATION BE DISTURBED BY THE CONTRACTOR, THE CONTRACTOR SHALL EMPLOY A NEW HAMPSHIRE LICENSED SURVEYOR TO REPLACE DISTURBED MONUMENTS.
17. PROVIDE INLET PROTECTION BARRIERS AT ALL CATCH BASINS/CURB INLETS WITHIN CONSTRUCTION LIMITS AS WELL AS CATCH BASINS/CURB INLETS THAT RECEIVE RUNOFF FROM CONSTRUCTION ACTIVITIES. INLET PROTECTION BARRIERS SHALL BE MAINTAINED FOR THE DURATION OF THE PROJECT. INLET PROTECTION BARRIERS SHALL BE "HIGH FLOW SILT SACK" BY ACF ENVIRONMENTAL OR EQUAL. INSPECT BARRIERS WEEKLY AND AFTER EACH RAIN EVENT OF 0.25 INCHES OR GREATER. CONTRACTOR SHALL COMPLETE A MAINTENANCE INSPECTION REPORT AFTER EACH INSPECTION. SEDIMENT DEPOSITS SHALL BE REMOVED AFTER EACH STORM EVENT OR MORE OFTEN IF THE FABRIC BECOMES CLOGGED OR SEDIMENT HAS ACCUMULATED TO 1/3 THE DESIGN DEPTH OF THE BARRIER.
18. THE CONTRACTOR SHALL PHASE DEMOLITION AND CONSTRUCTION AS REQUIRED TO PROVIDE CONTINUOUS SERVICE TO EXISTING BUSINESSES AND HOMES THROUGHOUT THE CONSTRUCTION PERIOD. EXISTING BUSINESS AND HOME SERVICES INCLUDE, BUT ARE NOT LIMITED TO ELECTRICAL, COMMUNICATION, FIRE PROTECTION, DOMESTIC WATER AND SEWER SERVICES. TEMPORARY SERVICES, IF REQUIRED, SHALL COMPLY WITH ALL FEDERAL, STATE, LOCAL AND UTILITY COMPANY STANDARDS. CONTRACTOR SHALL PROVIDE DETAILED CONSTRUCTION SCHEDULE TO OWNER PRIOR TO ANY DEMOLITION/CONSTRUCTION ACTIVITIES AND SHALL COORDINATE TEMPORARY SERVICES TO ABUTERS WITH THE UTILITY COMPANY AND AFFECTED ABUTTER.
19. EROSION CONTROL MEASURES SHALL BE INSTALLED PRIOR TO THE START OF ANY CLEARING OR DEMOLITION ACTIVITIES.
20. THE CONTRACTOR SHALL PAY ALL COSTS NECESSARY FOR TEMPORARY PARTITIONING, BARRICADING, FENCING, SECURITY AND SAFETY DEVICES REQUIRED FOR THE MAINTENANCE OF A CLEAN AND SAFE CONSTRUCTION SITE.
21. SAW CUT AND REMOVE PAVEMENT AND CONSTRUCT PAVEMENT TRENCH PATCH FOR ALL UTILITIES TO BE REMOVED AND PROPOSED UTILITIES LOCATED IN EXISTING PAVEMENT AREAS TO REMAIN.
22. ALL CONDITIONS ON THIS PLAN SHALL REMAIN IN EFFECT IN PERPETUITY PURSUANT TO THE REQUIREMENTS OF THE SITE PLAN REVIEW REGULATIONS.
23. WITH THE EXCEPTION OF THE NORWAY MAPLES IN THE 25' VEGETATED BUFFER, WHICH ARE TO REMAIN, INVASIVE SPECIES WITHIN THE 100' SHORELAND SETBACK WILL BE REMOVED. INVASIVE SPECIES WITHIN THE 25' VEGETATED BUFFER WILL BE FLAGGED IN FIELD BY THE LANDSCAPE ARCHITECT OR CERTIFIED ARBORIST TO BE REMOVED. INVASIVE SHRUBS WITHIN THE 25' VEGETATED BUFFER WITH CALIPER MEASURING GREATER THAN 3" SUCH AS BUCKTHORN AND AUTUMN OLIVE WILL BE FLUSH CUT REPEATEDLY TO KILL THE PLANT, LEAVING THE STUMPS IN PLACE. WOODY INVASIVES SMALLER THAN 3" CALIPER SHALL BE REMOVED WITH HAND TOOLS. AREAS OF SOIL DISTURBANCE FROM SUCH REMOVALS WILL BE LIMITED TO THE IMMEDIATE ROOT AREA SURROUNDING EACH PLANT, DRESSED WITH LOAM, REPLANTED WITH NEW ENGLAND WILDLIFE AND CONSERVATION SEED MIX AND STABILIZED WITH JUTE MESH STAKED IN PLACE. ALL OTHER AREAS DISTURBED BY HEADWALLS AND CULVERTS SHALL BE LOAMED, SEEDED WITH NEW ENGLAND WILDLIFE AND CONSERVATION SEED MIX AND STABILIZED WITH JUTE MESH.

LEGEND

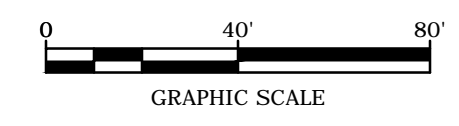
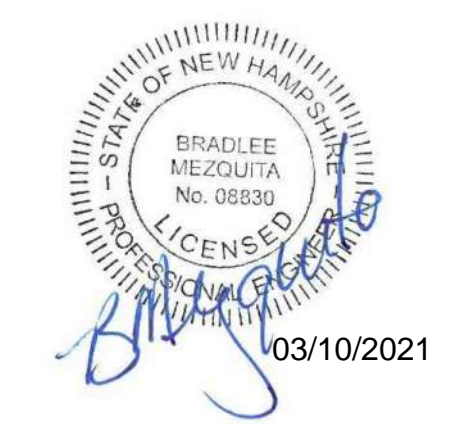
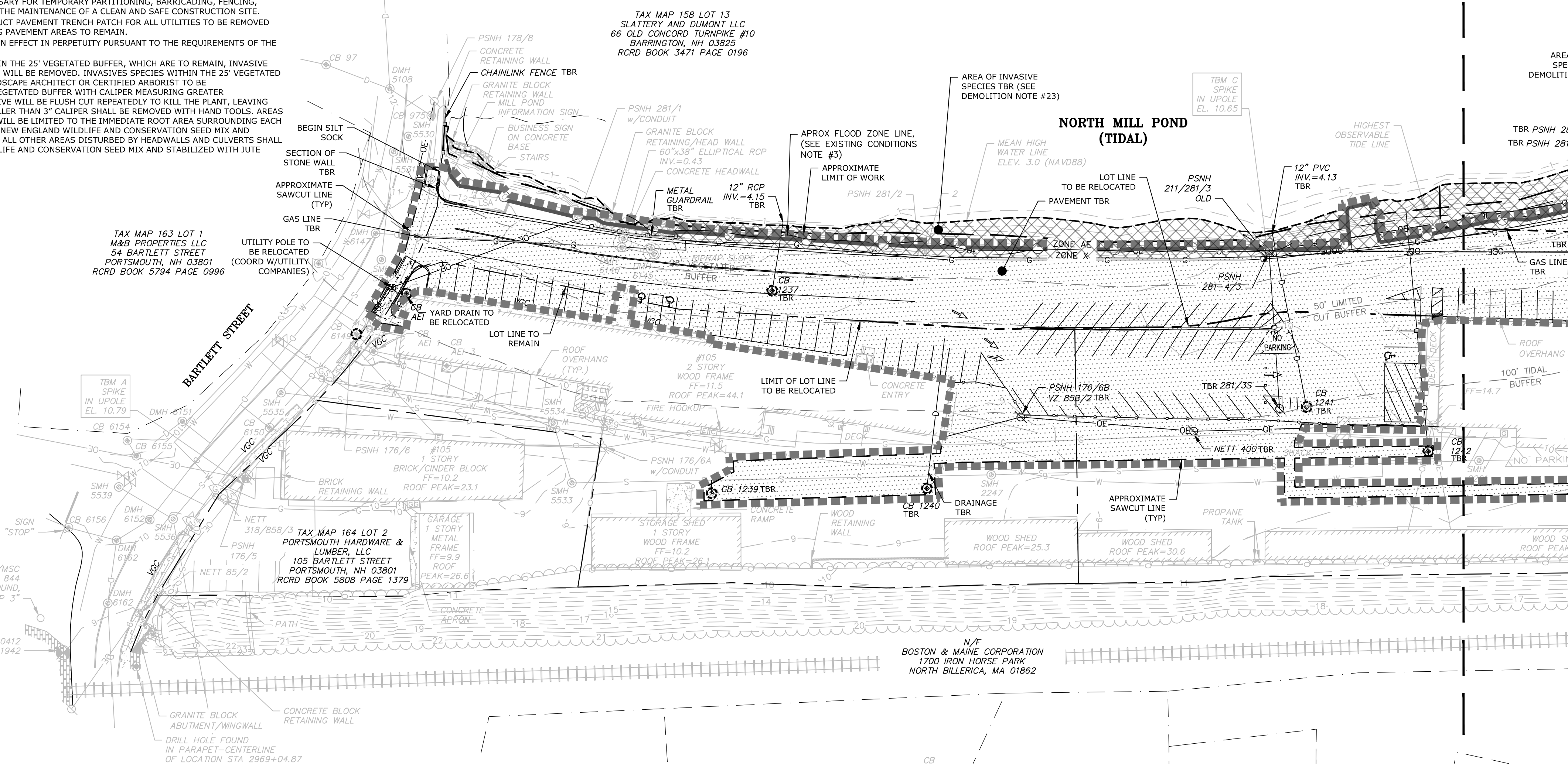
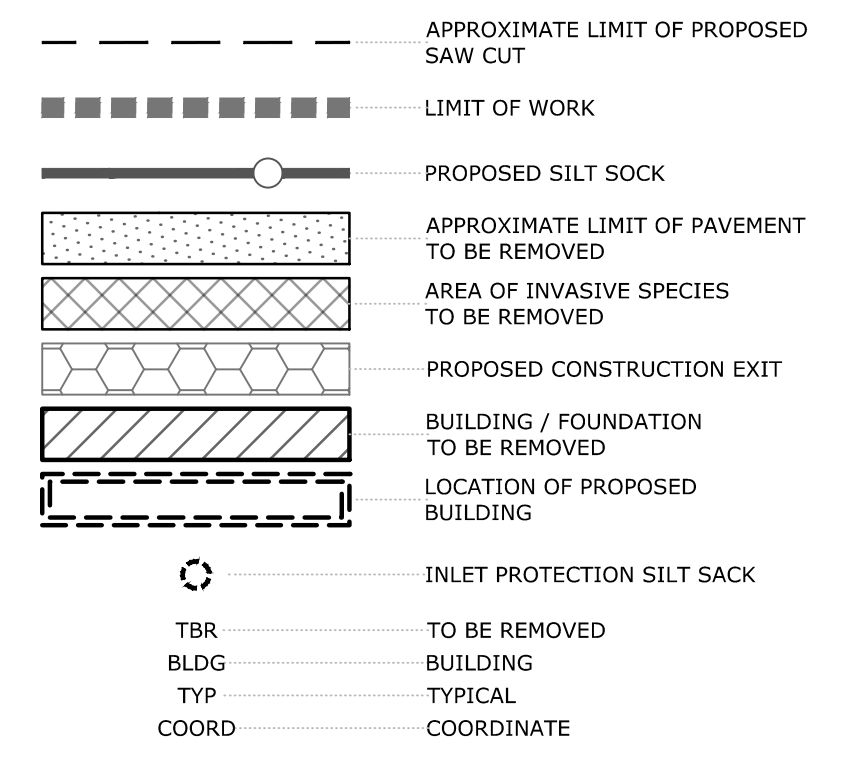

Proposed Multi-Family Development

Iron Horse Properties, LLC

105 Bartlett Street
Portsmouth,
New Hampshire

MARK	DATE	DESCRIPTION
I	3/10/2021	PB Submission
H	1/20/2021	TAC Resubmission
G	11/18/2020	TAC Resubmission
F	10/28/2020	Wetland CUP Resubmission
E	5/20/2020	TAC Resubmission
D	4/29/2020	Wetland CUP Submission
C	4/20/2020	TAC Submission
B	2/6/2020	Design Review Submission
A	1/2/2020	ZBA Submission

PROJECT NO:	C-0960-006
DATE:	April 20, 2020
FILE:	C-0960-006_C-SITE.DWG
DRAWN BY:	NAH
CHECKED:	PMC
APPROVED:	BML

EXISTING CONDITIONS AND DEMOLITION PLAN

SCALE: AS SHOWN

Last Saved: 3/10/2021 10:47:44 AM By: N.H. Manion
Plotted On: Mar 10, 2021 1:48:47 PM
Tighe & Bond, Inc. C:\Users\N.H. Manion\OneDrive\Documents\C-0960-006_105 Bartlett Street Drawings - Figures\AutoCAD\Sheet\C-0960-006_C-SITE.dwg

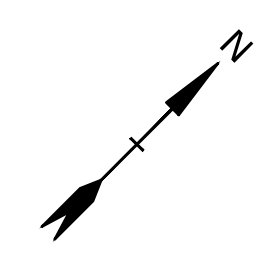

LEGEND

- APPROXIMATE LIMIT OF PROPOSED SAW CUT
- LIMIT OF WORK
- PROPOSED SILT SOCK
- APPROXIMATE LIMIT OF PAVEMENT TO BE REMOVED
- AREA OF INVASIVE SPECIES TO BE REMOVED
- PROPOSED CONSTRUCTION EXIT
- BUILDING / FOUNDATION TO BE REMOVED
- LOCATION OF PROPOSED BUILDING
- INLET PROTECTION SILT SACK
- TBR --- TO BE REMOVED
- BLDG --- BUILDING
- TYP --- TYPICAL
- COORD --- COORDINATE

- DEMOLITION NOTES:**
1. THE LOCATIONS OF UNDERGROUND UTILITIES ARE APPROXIMATE AND THE LOCATIONS ARE NOT GUARANTEED BY THE OWNER OR THE ENGINEER. IT IS THE CONTRACTOR'S RESPONSIBILITY TO LOCATE ALL UTILITIES, ANTICIPATE CONFLICTS, REPAIR EXISTING UTILITIES AND RELOCATE EXISTING UTILITIES REQUIRED TO COMPLETE THE WORK.
 2. THE CONTRACTOR SHALL VERIFY LOCATION OF ALL EXISTING UTILITIES. CALL DIG SAFE AT LEAST 72 HOURS PRIOR TO THE COMMENCEMENT OF ANY DEMOLITION/CONSTRUCTION ACTIVITIES.
 3. ALL MATERIALS SCHEDULED TO BE REMOVED SHALL BECOME THE PROPERTY OF THE CONTRACTOR UNLESS OTHERWISE SPECIFIED. THE CONTRACTOR SHALL DISPOSE OF ALL MATERIALS OFF-SITE IN ACCORDANCE WITH ALL FEDERAL, STATE, AND LOCAL REGULATIONS, ORDINANCES AND CODES.
 4. COORDINATE REMOVAL, RELOCATION, DISPOSAL OR SALVAGE OF UTILITIES WITH THE OWNER AND APPROPRIATE UTILITY COMPANY.
 5. ANY EXISTING WORK OR PROPERTY DAMAGED OR DISRUPTED BY CONSTRUCTION/ DEMOLITION ACTIVITIES SHALL BE REPLACED OR REPAIRED TO MATCH ORIGINAL EXISTING CONDITIONS BY THE CONTRACTOR AT NO ADDITIONAL COST TO THE OWNER.
 6. SAW CUT AND REMOVE PAVEMENT ONE (1) FOOT OFF PROPOSED EDGE OF PAVEMENT OR EXISTING CURB LINE IN ALL AREAS WHERE PAVEMENT TO BE REMOVED ABUTS EXISTING PAVEMENT OR CONCRETE TO REMAIN.
 7. IT IS THE CONTRACTOR'S RESPONSIBILITY TO FAMILIARIZE THEMSELVES WITH THE CONDITIONS OF ALL OF THE PERMIT APPROVALS.
 8. THE CONTRACTOR SHALL OBTAIN AND PAY FOR ADDITIONAL PERMITS, NOTICES AND FEES NECESSARY TO COMPLETE THE WORK AND ARRANGE FOR AND PAY FOR NECESSARY INSPECTIONS AND APPROVALS FROM THE AUTHORITIES HAVING JURISDICTION.
 9. THE CONTRACTOR SHALL BE RESPONSIBLE FOR ALL DEMOLITION AND OFF-SITE DISPOSAL OF MATERIALS REQUIRED TO COMPLETE THE WORK, EXCEPT FOR WORK NOTED TO BE COMPLETED BY OTHERS.
 10. UTILITIES SHALL BE TERMINATED AT THE MAIN LINE PER UTILITY COMPANY STANDARDS. THE CONTRACTOR SHALL REMOVE ALL ABANDONED UTILITIES LOCATED WITHIN THE LIMITS OF WORK.
 11. CONTRACTOR SHALL VERIFY ORIGIN OF ALL DRAINS AND UTILITIES PRIOR TO REMOVAL/TERMINATION TO DETERMINE IF DRAINS OR UTILITY IS ACTIVE, AND SERVICES ANY ON OR OFF-SITE STRUCTURE TO REMAIN. THE CONTRACTOR SHALL NOTIFY ENGINEER IMMEDIATELY OF ANY SUCH UTILITY FOUND AND SHALL MAINTAIN THESE UTILITIES UNTIL PERMANENT SOLUTION IS IN PLACE.
 12. PAVEMENT REMOVAL LIMITS ARE SHOWN FOR CONTRACTOR'S CONVENIENCE. ADDITIONAL PAVEMENT REMOVAL MAY BE REQUIRED DEPENDING ON THE CONTRACTOR'S OPERATION. CONTRACTOR TO VERIFY FULL LIMITS OF PAVEMENT REMOVAL PRIOR TO BID.

13. ALL ITEMS WITHIN THE LIMIT OF WORK ARE TO REMAIN UNLESS SPECIFICALLY IDENTIFIED TO BE REMOVED OR OTHERWISE ALTERED BY THE CONTRACTOR. ITEMS TO BE REMOVED INCLUDE, BUT ARE NOT LIMITED TO: CONCRETE, PAVEMENT, MANHOLES, CATCH BASINS, UNDERGROUND PIPING & UTILITIES, POLES, STAIRS, STRUCTURES, FENCES, RAMPS, BUILDING FOUNDATIONS, TREES, AND LANDSCAPING. THE CONTRACTOR SHALL CONFIRM WITH THE ENGINEER IF THE TREATMENT OF CERTAIN ITEMS IS UNCLEAR.
14. COORDINATE ALL WORK WITHIN THE PUBLIC RIGHT OF WAYS WITH THE CITY OF PORTSMOUTH.
15. REMOVE TREES AND BRUSH AS REQUIRED FOR COMPLETION OF WORK. CONTRACTOR SHALL GRUB AND REMOVE ALL STUMPS WITHIN LIMITS OF WORK AND DISPOSE OF OFF SITE IN ACCORDANCE WITH FEDERAL, STATE, AND LOCAL LAWS AND REGULATIONS.
16. CONTRACTOR SHALL PROTECT ALL PROPERTY MONUMENTATION THROUGHOUT DEMOLITION AND CONSTRUCTION OPERATIONS. SHOULD ANY MONUMENTATION BE DISTURBED BY THE CONTRACTOR, THE CONTRACTOR SHALL EMPLOY A NEW HAMPSHIRE LICENSED SURVEYOR TO REPLACE DISTURBED MONUMENTS.
17. PROVIDE INLET PROTECTION BARRIERS AT ALL CATCH BASINS/CURB INLETS WITHIN CONSTRUCTION LIMITS AS WELL AS CATCH BASINS/CURB INLETS THAT RECEIVE RUNOFF FROM CONSTRUCTION ACTIVITIES. INLET PROTECTION BARRIERS SHALL BE MAINTAINED FOR THE DURATION OF THE PROJECT. INLET PROTECTION BARRIERS SHALL BE "HIGH FLOW SILT SACK" BY ACF ENVIRONMENTAL OR EQUAL. INSPECT BARRIERS WEEKLY AND AFTER EACH RAIN EVENT OF 0.25 INCHES OR GREATER. CONTRACTOR SHALL COMPLETE A MAINTENANCE INSPECTION REPORT AFTER EACH INSPECTION. SEDIMENT DEPOSITS SHALL BE REMOVED AFTER EACH STORM EVENT OR MORE OFTEN IF THE FABRIC BECOMES CLOGGED OR SEDIMENT HAS ACCUMULATED TO 1/3 THE DESIGN DEPTH OF THE BARRIER.
18. THE CONTRACTOR SHALL PHASE DEMOLITION AND CONSTRUCTION AS REQUIRED TO PROVIDE CONTINUOUS SERVICE TO EXISTING BUSINESSES AND HOMES THROUGHOUT THE CONSTRUCTION PERIOD. EXISTING BUSINESS AND HOME SERVICES INCLUDE, BUT ARE NOT LIMITED TO ELECTRICAL, COMMUNICATION, FIRE PROTECTION, DOMESTIC WATER AND SEWER SERVICES. TEMPORARY SERVICES, IF REQUIRED, SHALL COMPLY WITH ALL FEDERAL, STATE, LOCAL AND UTILITY COMPANY STANDARDS. CONTRACTOR SHALL PROVIDE DETAILED CONSTRUCTION SCHEDULE TO OWNER PRIOR TO ANY DEMOLITION/CONSTRUCTION ACTIVITIES AND SHALL COORDINATE TEMPORARY SERVICES TO ABUTTERS WITH THE UTILITY COMPANY AND AFFECTED ABUTTER.
19. EROSION CONTROL MEASURES SHALL BE INSTALLED PRIOR TO THE START OF ANY CLEARING OR DEMOLITION ACTIVITIES.
20. THE CONTRACTOR SHALL PAY ALL COSTS NECESSARY FOR TEMPORARY PARTITIONING, BARRICADING, FENCING, SECURITY AND SAFETY DEVICES REQUIRED FOR THE MAINTENANCE OF A CLEAN AND SAFE CONSTRUCTION SITE.
21. SAW CUT AND REMOVE PAVEMENT AND CONSTRUCT PAVEMENT TRENCH PATCH FOR ALL UTILITIES TO BE REMOVED AND PROPOSED UTILITIES LOCATED IN EXISTING PAVEMENT AREAS TO REMAIN.
22. ALL CONDITIONS ON THIS PLAN SHALL REMAIN IN EFFECT IN PERPETUITY PURSUANT TO THE REQUIREMENTS OF THE SITE PLAN REVIEW REGULATIONS.
23. WITH THE EXCEPTION OF THE NORWAY MAPLES IN THE 25' VEGETATED BUFFER, WHICH ARE TO REMAIN, INVASIVE SPECIES WITHIN THE 100' SHORELAND SETBACK WILL BE REMOVED. INVASIVE SPECIES WITHIN THE 25' VEGETATED BUFFER WILL BE FLAGGED IN FIELD BY THE LANDSCAPE ARCHITECT OR CERTIFIED ARBORIST TO BE REMOVED. INVASIVE SHRUBS WITHIN THE 25' VEGETATED BUFFER WITH CALIPER MEASURING GREATER THAN 3" SUCH AS BUCKTHORN AND AUTUMN OLIVE WILL BE FLUSH CUT REPEATEDLY TO KILL THE PLANT, LEAVING THE STUMPS IN PLACE. WOODY INVASIVES SMALLER THAN 3" CALIPER SHALL BE REMOVED WITH HAND TOOLS. AREAS OF SOIL DISTURBANCE FROM SUCH REMOVALS WILL BE LIMITED TO THE IMMEDIATE ROOT AREA SURROUNDING EACH PLANT, DRESSED WITH LOAM, REPLANTED WITH NEW ENGLAND WILDLIFE AND CONSERVATION SEED MIX AND STABILIZED WITH JUTE MESH STAKED IN PLACE. ALL OTHER AREAS DISTURBED BY HEADWALLS AND CULVERTS SHALL BE LOAMED, SEEDDED WITH NEW ENGLAND WILDLIFE AND CONSERVATION SEED MIX AND STABILIZED WITH JUTE MESH.

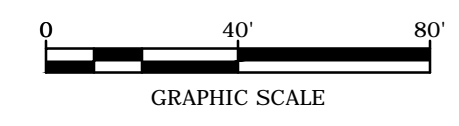
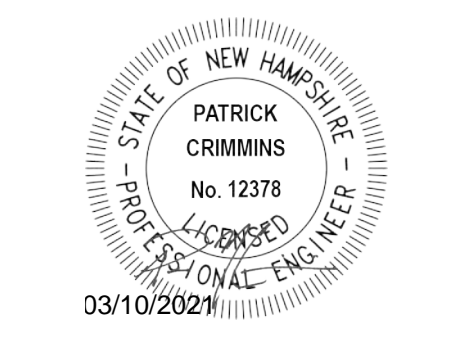
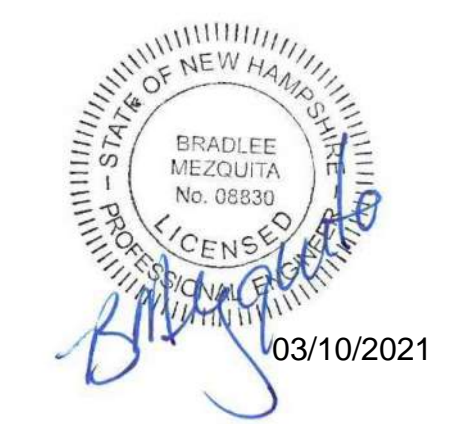

NORTH MILL POND (TIDAL)

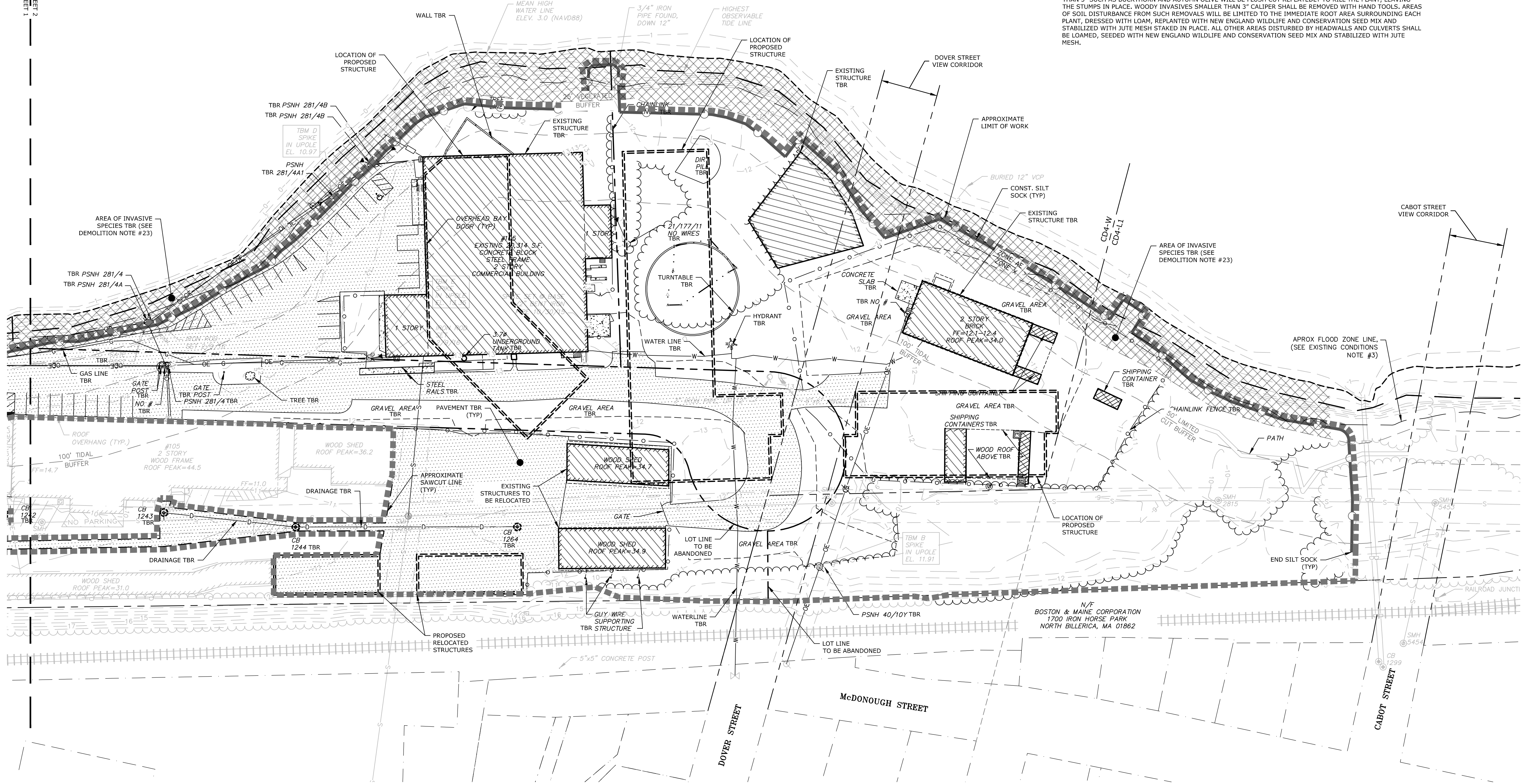

Proposed Multi-Family Development

Iron Horse Properties, LLC

**105 Bartlett Street
Portsmouth,
New Hampshire**

MARK	DATE	DESCRIPTION
I	3/10/2021	PB Submission
H	1/20/2021	TAC Resubmission
G	11/18/2020	TAC Resubmission
F	10/28/2020	Wetland CUP Resubmission
E	5/20/2020	TAC Resubmission
D	4/29/2020	Wetland CUP Submission
C	4/20/2020	TAC Submission
B	2/6/2020	Design Review Submission
A	1/2/2020	ZBA Submission

PROJECT NO:	C-0960-006
DATE:	April 20, 2020
FILE:	C-0960-006_C-SITE.DWG
DRAWN BY:	NAH
CHECKED:	PMC
APPROVED:	BML

EXISTING CONDITIONS AND DEMOLITION PLAN

SCALE: AS SHOWN

C-101.2

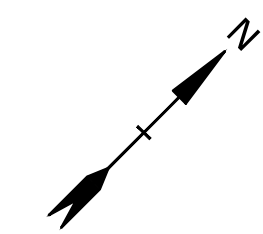

SITE DATA:
 PROJECT LOCATION: TAX MAP 157, LOT 1
 TAX MAP 157, LOT 2
 TAX MAP 164, LOT 1
 TAX MAP 164, LOT 4-2

SITE ZONING DISTRICT: 105 BARTLETT STREET
 PORTSMOUTH, NEW HAMPSHIRE
 CHARACTER DISTRICT 4 (CD4-W)
 CHARACTER DISTRICT 4 (CD4-L1)
 WEST END INCENTIVE OVERLAY DISTRICT

ALLOWED USE ON SITE: PROFESSIONAL OFFICE, BUSINESS OFFICE, MULTIFAMILY DWELLING

PROPOSED GROUND FLOOR USES:
 BUILDING A & B: RESIDENTIAL
 BUILDING C: RESIDENTIAL & AMENITY SPACE

DEVELOPMENT STANDARDS

BUILDING PLACEMENT (PRINCIPAL BUILDING):	REQUIRED (CD4-W)	PROPOSED (CD4-W)
MAX PRINCIPAL FRONT YARD:	10 FT	0 FT
MINIMUM SIDE YARD:	15 FT ⁽¹⁾	<6 FT ⁽²⁾
MINIMUM REAR YARD:	5 FT	214.54 FT
FRONT LOT LINE BUILDOUT:	50% MIN	54%

BUILDING AND LOT OCCUPATION:	REQUIRED (CD4-W)	PROPOSED (CD4-W)
MAXIMUM BUILDING BLOCK LENGTH:	200 FT	185 FT
MAXIMUM FAÇADE MODULATION LENGTH:	80 FT	<80 FT
MAXIMUM ENTRANCE SPACING:	50 FT	<50 FT
MAXIMUM BUILDING COVERAGE:	80% ⁽³⁾	±20.9%
MAXIMUM BUILDING FOOTPRINT:	20,000 SF ⁽⁴⁾	19,214 SF
MINIMUM LOT AREA:	5,000 SF	205,804 SF
MINIMUM LOT AREA PER DWELLING UNIT:	NR ⁽⁵⁾	58.1%
MINIMUM OPEN SPACE:	15%	14,300 SF
MAXIMUM GROUND FLOOR GFA PER USE:	15,000 SF	

- (1) - PER 10.516.20, MINIMUM SIDE YARD SETBACK ADJOINING A RAILROAD ADJOINING A RAILROAD RIGHT OF WAY SHALL BE 15FT
- (2) - VARIANCE GRANTED BY ZONING BOARD OF ADJUSTMENT ON JANUARY 22, 2020
- (3) - MAXIMUM BUILDING COVERAGE ALLOWED IN THE WEST END INCENTIVE OVERLAY DISTRICT FOR PROVIDING AT LEAST 20% OF THE SITE TO BE ASSIGNED AS COMMUNITY SPACE.
- (4) - ADDITIONAL 5,000 SF OF GFA (INCREASED FROM 15,000 SF) ALLOWED FOR PROVIDING AT LEAST 20% OF THE SITE TO BE ASSIGNED AS COMMUNITY SPACE.
- (5) - NO MINIMUM LOT AREA PER DWELLING UNIT REQUIRED IN THE WEST END INCENTIVE OVERLAY DISTRICT FOR PROVIDING AT LEAST 20% OF THE SITE TO BE ASSIGNED AS COMMUNITY SPACE.

BUILDING FORM (PRINCIPAL BUILDING):	REQUIRED (CD4-W)	PROPOSED (CD4-W)
BUILDING HEIGHT:	4 STORIES ⁽¹⁾ 50' MAX ⁽²⁾	4 STORIES, 49'-2"
MAXIMUM FINISHED FLOOR SURFACE OF GROUND FLOOR ABOVE SIDEWALK GRADE:	36 IN	<36 IN
MINIMUM GROUND STORY HEIGHT:	9 FT ⁽³⁾	12 FT
MINIMUM SECOND STORY HEIGHT:	N/A	
FAÇADE GLAZING:		
SHOPFRONT FAÇADE:	70% MIN	>70%
OTHER FAÇADE TYPES:	20% TO 50%	
ALLOWED ROOF TYPES:	FLAT, GABLE, HIP, GAMBREL, OR MANSARD	FLAT
ROOF PITCH, IF ANY:		
GABLE:	6:12 - 12:12	
HIP:	3:12 MIN	
MANSARD/GAMBREL:	6:12 - 30:12	
ALLOWED BUILDING TYPES:	APARTMENT BUILDING	APARTMENT BUILDING

- (1) - ADDITIONAL 1 STORY (INCREASED FROM 1 AND 3 RESPECTIVELY) ALLOWED FOR PROVIDING AT LEAST 20% OF THE SITE TO BE ASSIGNED AS COMMUNITY SPACE.
- (2) - ADDITIONAL 10' OF BUILDING HEIGHT (INCREASED FROM 20' AND 40' RESPECTIVELY) ALLOWED FOR PROVIDING AT LEAST 20% OF THE SITE TO BE ASSIGNED AS COMMUNITY SPACE.
- (3) - MINIMUM GROUND STORY HEIGHT ALLOWED IN WEST END INCENTIVE OVERLAY DISTRICT FOR PROVIDING AT LEAST 20% OF THE SITE TO BE ASSIGNED AS COMMUNITY SPACE.

COMMUNITY SPACE:	REQUIRED (CD4-W)	PROPOSED (CD4-W)
	44,154 SF	47,703 SF
	20%	23%

ZONING VARIANCES:

REQUIREMENT:	SECTION:	GRANTED:
(1) - MINIMUM SIDE YARD SETBACK FROM RAILROAD:	10.516.20	1/22/2020

OFF-STREET PARKING REQUIREMENTS:

PARKING SPACES REQUIRED:

DWELLING UNITS:	BUILDING A, 16 UNITS	16 SPACES
500 SF TO 750 SF 1.0 SPACES PER UNIT	BUILDING B, 31 UNITS	31 SPACES
	BUILDING C, 17 UNITS	17 SPACES
TOTAL MINIMUM PARKING SPACES REQUIRED =		64 SPACES

OVER 750 SF 1.3 SPACES PER UNIT	BUILDING A, 20 UNITS	26.0 SPACES
	BUILDING B, 39 UNITS <td>50.7 SPACES </td>	50.7 SPACES
	BUILDING C, 29 UNITS <td>37.7 SPACES </td>	37.7 SPACES
TOTAL MINIMUM PARKING SPACES REQUIRED =		114.4 SPACES

VISITORS:	152 UNITS	31 SPACES
1 SPACE FOR EVERY 5 DWELLING UNITS		
TOTAL MINIMUM PARKING SPACES REQUIRED =		210 SPACES

TOTAL PARKING SPACES PROVIDED:

TOTAL PARKING SPACES PROVIDED =	95 SPACES (SURFACE PARKING)
	53 SPACES (BUILDING A, UNDERGROUND)
	42 SPACES (BUILDING B, UNDERGROUND)
	20 SPACES (PRIVATE ROADWAY) ⁽¹⁾
	210 SPACES

ADA SPACES REQUIRED=	9 SPACES
ADA SPACES PROVIDED=	9 SPACES (4 SPACES INCLUDED IN SURFACE PARKING COUNT OF 95, 4 SPACES INCLUDED IN BASEMENT PARKING COUNT OF 95, 1 SPACE INCLUDED IN PRIVATE ROADWAY COUNT OF 20)

(1) - CONDITIONAL USE PERMIT REQUIRED FOR SHARED PARKING ON SEPARATE LOT

PARKING STALL LAYOUT:	REQUIRED	PROPOSED
DRIVE AISLE WIDTH:	8.5' X 19' 24 FT	8.5' X 19' 24 FT

BIKE SPACES REQUIRED:

1 BIKE SPACE / 5 DWELLING UNITS, MAXIMUM OF 30 SPACES	30 SPACES	30 SPACES*
---	-----------	------------

*INDOOR BIKE STORAGE WILL BE PROVIDED THAT MEETS OR EXCEEDS THE REQUIREMENT.

LEGEND

	PROPERTY LINE
	PROPOSED PROPERTY LINE
	PROPOSED EDGE OF PAVEMENT
	PROPOSED CURB
	PROPOSED BUILDING
	PROPOSED PAVEMENT SECTION
	PROPOSED POROUS PAVEMENT SECTION
	PROPOSED CONCRETE SIDEWALK
	PROPOSED BOLLARD
	BUILDING TYPING
	COORDINATE
	30'R
	VGC
	SGC
	MVGC

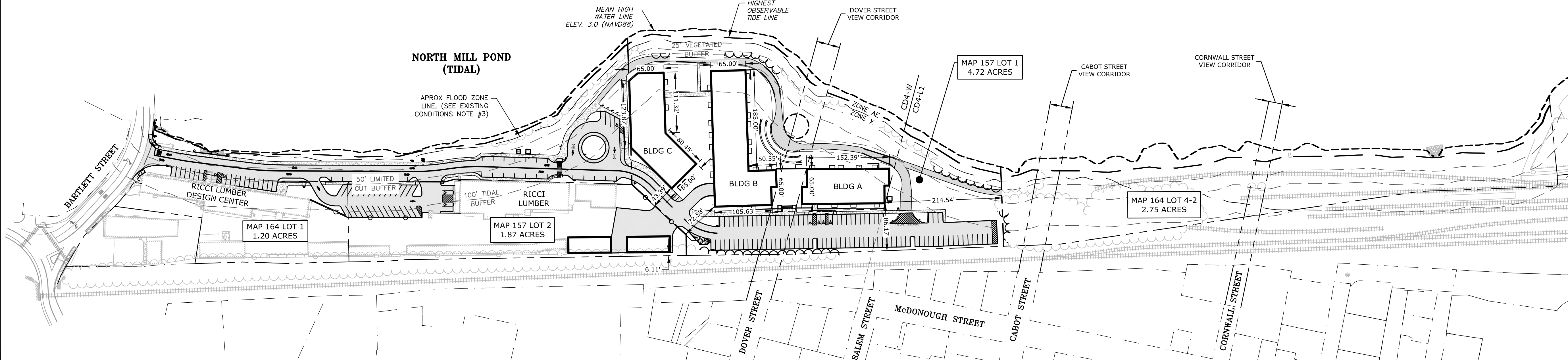
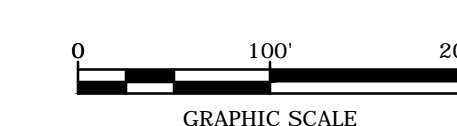
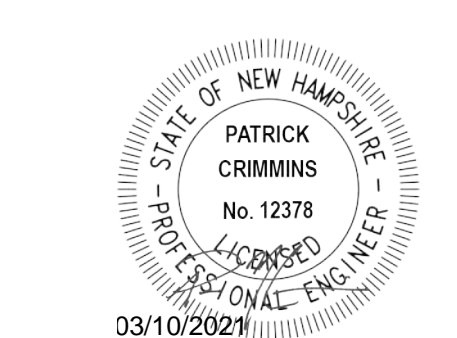
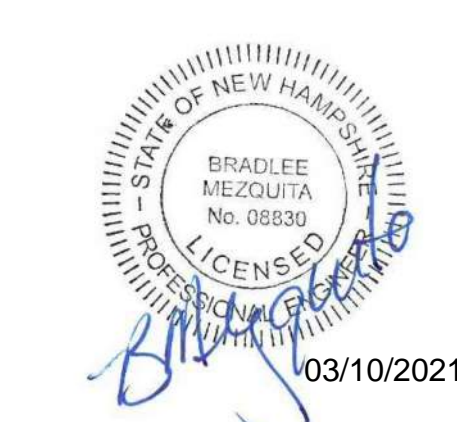

Proposed Multi-Family Development

Iron Horse Properties, LLC

105 Bartlett Street
 Portsmouth,
 New Hampshire

MARK	DATE	DESCRIPTION
I	3/10/2021	PB Submission
H	1/20/2021	TAC Resubmission
G	11/18/2020	TAC Resubmission
F	10/28/2020	Wetland CUP Resubmission
E	5/20/2020	TAC Resubmission
D	4/29/2020	Wetland CUP Submission
C	4/20/2020	TAC Submission
B	2/6/2020	Design Review Submission
A	1/2/2020	ZBA Submission

PROJECT NO:	C-0960-006
DATE:	April 20, 2020
FILE:	C-0960-006_C-SITE.DWG
DRAWN BY:	NAH
CHECKED:	PMC
APPROVED:	BML

OVERALL SITE PLAN

SCALE: AS SHOWN

Last Saved: 3/10/2021 1:48:47pm By: N.H. Hansen
 Plotted On: Mar 10, 2021 1:58:47pm By: Tighe & Bond
 Figures: AutoCAD, Sheet: C-0960-006_C-SITE.dwg

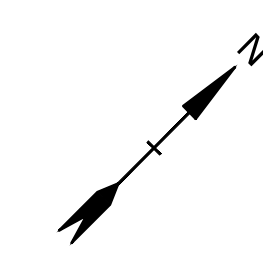

SITE NOTES:

1. STRIPE PARKING AREAS AS SHOWN, INCLUDING PARKING SPACES, STOP BARS, ADA SYMBOLS, PAINTED ISLANDS, CROSS WALKS, ARROWS, LEGENDS AND CENTERLINES SHALL BE THERMOPLASTIC MATERIAL. THERMOPLASTIC MATERIAL SHALL MEET THE REQUIREMENTS OF AASHTO M249. (ALL MARKINGS EXCEPT CENTERLINE AND MEDIAN ISLANDS TO BE CONSTRUCTED USING WHITE TRAFFIC PAINT. CENTERLINE AND MEDIAN ISLANDS TO BE CONSTRUCTED USING YELLOW TRAFFIC PAINT. ALL TRAFFIC PAINT SHALL MEET THE REQUIREMENTS OF AASHTO M248 TYPE "F").
2. ALL PAVEMENT MARKINGS AND SIGNS TO CONFORM TO "MANUAL ON UNIFORM TRAFFIC CONTROL DEVICES", "STANDARD ALPHABETS FOR HIGHWAY SIGNS AND PAVEMENT MARKINGS", AND THE AMERICANS WITH DISABILITIES ACT REQUIREMENTS, LATEST EDITIONS.
3. SEE DETAILS FOR PARKING STALL MARKINGS, ADA SYMBOLS, SIGNS AND SIGN POSTS.
4. CENTERLINES SHALL BE FOUR (4) INCH WIDE YELLOW LINES. STOP BARS SHALL BE EIGHTEEN (18) INCHES WIDE.
5. PAINTED ISLANDS SHALL BE FOUR (4) INCH WIDE DIAGONAL LINES AT 3'-0" O.C. BORDERED BY FOUR (4) INCH WIDE LINES.
6. THE CONTRACTOR SHALL EMPLOY A NEW HAMPSHIRE LICENSED LAND SURVEYOR TO DETERMINE ALL LINES AND GRADES.
7. CLEAN AND COAT VERTICAL FACE OF EXISTING PAVEMENT AT SAW CUT LINE WITH RS-1 EMULSION IMMEDIATELY PRIOR TO PLACING NEW BITUMINOUS CONCRETE.
8. ALL MATERIALS AND CONSTRUCTION SHALL CONFORM WITH APPLICABLE FEDERAL, STATE, AND LOCAL CODES & SPECIFICATIONS.
9. COORDINATE ALL WORK WITHIN PUBLIC RIGHT OF WAY WITH THE CITY OF PORTSMOUTH.
10. CONTRACTOR TO SUBMIT AS-BUILT PLANS IN DIGITAL FORMAT (.DWG AND .PDF FILES) ON DISK TO THE OWNER AND ENGINEER UPON COMPLETION OF THE PROJECT. AS-BUILTS SHALL BE PREPARED AND CERTIFIED BY A NEW HAMPSHIRE LICENSED LAND SURVEYOR.
11. SEE BUILDING DRAWINGS FOR ALL CONCRETE PADS & SIDEWALKS ADJACENT TO BUILDING.
12. ALL WORK SHALL CONFORM TO THE CITY OF PORTSMOUTH DEPARTMENT OF PUBLIC WORKS, STANDARD SPECIFICATIONS.
13. CONTRACTOR TO PROVIDE BACKFILL AND COMPACTION AT CURB LINE AFTER CONCRETE FORMS FOR SIDEWALKS AND PADS HAVE BEEN STRIPPED. COORDINATE WITH BUILDING CONTRACTOR.
14. COORDINATE ALL WORK ADJACENT TO BUILDING WITH BUILDING CONTRACTOR.
15. THE PROPERTY MANAGER WILL BE RESPONSIBLE FOR TIMELY SNOW REMOVAL FROM ALL PRIVATE SIDEWALKS, DRIVEWAYS, AND PARKING AREAS. SNOW REMOVAL WILL BE HAULED OFF-SITE AND LEGALLY DISPOSED OF WHEN SNOW BANKS EXCEED 3 FEET IN HEIGHT.
16. ALL DIMENSIONS ARE TO THE FACE OF CURB UNLESS OTHERWISE NOTED.
17. ALL CONDITIONS ON THIS PLAN SHALL REMAIN IN EFFECT IN PERPETUITY PURSUANT TO THE REQUIREMENTS OF THE SITE PLAN REVIEW REGULATIONS.
18. THIS SITE PLAN SHALL BE RECORDED IN THE ROCKINGHAM COUNTY REGISTRY OF DEEDS. ALL IMPROVEMENTS SHOWN ON THIS SITE PLAN SHALL BE CONSTRUCTED AND MAINTAINED IN ACCORDANCE WITH THE PLAN BY THE PROPERTY OWNER AND ALL FUTURE PROPERTY OWNERS. NO CHANGES SHALL BE MADE TO THIS SITE PLAN WITHOUT THE EXPRESS APPROVAL OF THE PORTSMOUTH PLANNING DIRECTOR.
19. THE APPLICANT SHALL HAVE A SITE SURVEY CONDUCTED BY A RADIO COMMUNICATIONS CARRIER APPROVED BY THE CITY'S COMMUNICATIONS DIVISION. THE RADIO COMMUNICATIONS CARRIER MUST BE FAMILIAR AND CONVERSANT WITH THE POLICE AND RADIO CONFIGURATION. IF THE SITE SURVEY INDICATES THAT IT IS NECESSARY TO INSTALL A SIGNAL REPEATER EITHER ON OR NEAR THE PROPOSED PROJECT, THOSE COSTS SHALL BE THE RESPONSIBILITY OF THE PROPERTY OWNER. THE OWNER SHALL COORDINATE WITH THE SUPERVISOR OF RADIO COMMUNICATIONS FOR THE CITY.
20. ALL TREES TO BE PLANTED ARE TO BE INSTALLED UNDER THE SUPERVISION OF THE CITY OF PORTSMOUTH DPW USING STANDARD INSTALLATION METHODS.
21. THE APPLICATION SHALL PREPARE A CONSTRUCTION MITIGATION AND MANAGEMENT PLAN (CMMP) FOR REVIEW AND APPROVAL BY THE CITY'S LEGAL AND PLANNING DEPARTMENTS.

LEGEND

- PROPERTY LINE
- - - PROPOSED PROPERTY LINE
- ===== PROPOSED EDGE OF PAVEMENT
- ===== PROPOSED CURB
- ▭ PROPOSED BUILDING
- ▭ PROPOSED PAVEMENT SECTION
- ▭ PROPOSED POROUS PAVEMENT SECTION
- ▭ PROPOSED CONCRETE SIDEWALK
- PROPOSED BOLLARD
- BLDG BUILDING
- TYP TYPICAL
- COORD COORDINATE
- 30'R PROPOSED CURB RADIUS
- VGC PROPOSED VERTICAL GRANITE CURB
- SGC PROPOSED SLOPED GRANITE CURB
- MVGC PROPOSED MOUNTABLE VERTICAL GRANITE CURB

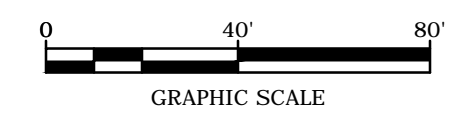
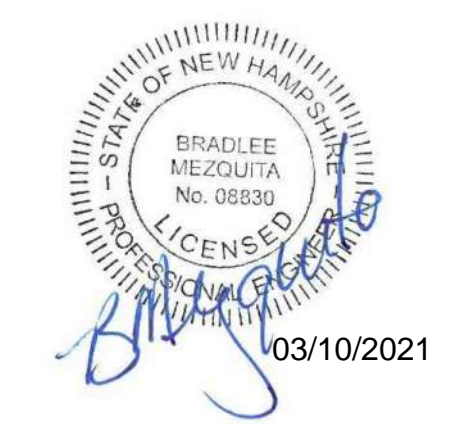
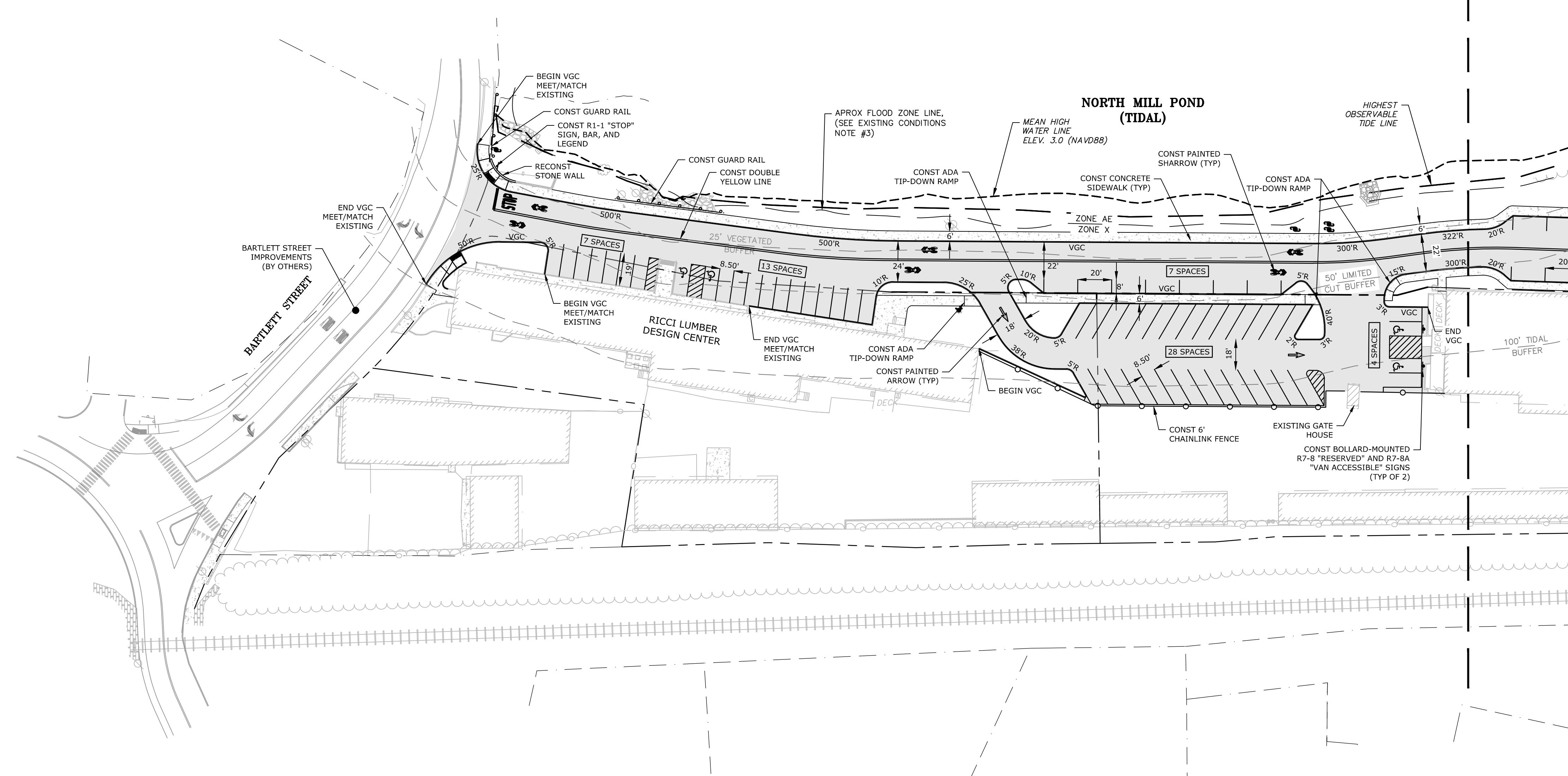

Proposed Multi-Family Development

Iron Horse Properties, LLC

**105 Bartlett Street
Portsmouth,
New Hampshire**

I	3/10/2021	PB Submission
H	1/20/2021	TAC Resubmission
G	11/18/2020	TAC Resubmission
F	10/28/2020	Wetland CUP Resubmission
E	5/20/2020	TAC Resubmission
D	4/29/2020	Wetland CUP Submission
C	4/20/2020	TAC Submission
B	2/6/2020	Design Review Submission
A	1/2/2020	ZBA Submission

PROJECT NO:	C-0960-006
DATE:	April 20, 2020
FILE:	C-0960-006_C-SITE.DWG
DRAWN BY:	NAH
CHECKED:	PMC
APPROVED:	BML

SITE PLAN

SCALE: AS SHOWN

C-102.1

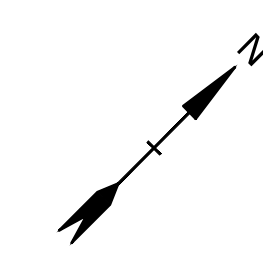

LEGEND

- PROPERTY LINE
- - - PROPOSED PROPERTY LINE
- ==== PROPOSED EDGE OF PAVEMENT
- ===== PROPOSED CURB
- [] PROPOSED BUILDING
- [] PROPOSED PAVEMENT SECTION
- [] PROPOSED POROUS PAVEMENT SECTION
- [] PROPOSED CONCRETE SIDEWALK
- BLDG
- TYP
- COORD
- 30'R
- VGC
- SGC
- MVGC
- PROPOSED BOLLARD
- BUILDING
- TYPICAL
- COORDINATE
- PROPOSED CURB RADIUS
- PROPOSED VERTICAL GRANITE CURB
- PROPOSED SLOPED GRANITE CURB
- PROPOSED MOUNTABLE VERTICAL GRANITE CURB

SITE NOTES:

1. STRIPE PARKING AREAS AS SHOWN, INCLUDING PARKING SPACES, STOP BARS, ADA SYMBOLS, PAINTED ISLANDS, CROSS WALKS, ARROWS, LEGENDS AND CENTERLINES SHALL BE THERMOPLASTIC MATERIAL. THERMOPLASTIC MATERIAL SHALL MEET THE REQUIREMENTS OF AASHTO M249. (ALL MARKINGS EXCEPT CENTERLINE AND MEDIAN ISLANDS TO BE CONSTRUCTED USING WHITE TRAFFIC PAINT. CENTERLINE AND MEDIAN ISLANDS TO BE CONSTRUCTED USING YELLOW TRAFFIC PAINT. ALL TRAFFIC PAINT SHALL MEET THE REQUIREMENTS OF AASHTO M248 TYPE "F").
2. ALL PAVEMENT MARKINGS AND SIGNS TO CONFORM TO "MANUAL ON UNIFORM TRAFFIC CONTROL DEVICES", "STANDARD ALPHABETS FOR HIGHWAY SIGNS AND PAVEMENT MARKINGS", AND THE AMERICANS WITH DISABILITIES ACT REQUIREMENTS, LATEST EDITIONS.
3. SEE DETAILS FOR PARKING STALL MARKINGS, ADA SYMBOLS, SIGNS AND SIGN POSTS.
4. CENTERLINES SHALL BE FOUR (4) INCH WIDE YELLOW LINES. STOP BARS SHALL BE EIGHTEEN (18) INCHES WIDE.
5. PAINTED ISLANDS SHALL BE FOUR (4) INCH WIDE DIAGONAL LINES AT 3'-0" O.C. BORDERED BY FOUR (4) INCH WIDE LINES.
6. THE CONTRACTOR SHALL EMPLOY A NEW HAMPSHIRE LICENSED LAND SURVEYOR TO DETERMINE ALL LINES AND GRADES.
7. CLEAN AND COAT VERTICAL FACE OF EXISTING PAVEMENT AT SAW CUT LINE WITH RS-1 EMULSION IMMEDIATELY PRIOR TO PLACING NEW BITUMINOUS CONCRETE.
8. ALL MATERIALS AND CONSTRUCTION SHALL CONFORM WITH APPLICABLE FEDERAL, STATE, AND LOCAL CODES & SPECIFICATIONS.
9. COORDINATE ALL WORK WITHIN PUBLIC RIGHT OF WAY WITH THE CITY OF PORTSMOUTH.
10. CONTRACTOR TO SUBMIT AS-BUILT PLANS IN DIGITAL FORMAT (.DWG AND .PDF FILES) ON DISK TO THE OWNER AND ENGINEER UPON COMPLETION OF THE PROJECT. AS-BUILTS SHALL BE PREPARED AND CERTIFIED BY A NEW HAMPSHIRE LICENSED LAND SURVEYOR.
11. SEE BUILDING DRAWINGS FOR ALL CONCRETE PADS & SIDEWALKS ADJACENT TO BUILDING.
12. ALL WORK SHALL CONFORM TO THE CITY OF PORTSMOUTH DEPARTMENT OF PUBLIC WORKS, STANDARD SPECIFICATIONS.
13. CONTRACTOR TO PROVIDE BACKFILL AND COMPACTION AT CURB LINE AFTER CONCRETE FORMS FOR SIDEWALKS AND PADS HAVE BEEN STRIPPED. COORDINATE WITH BUILDING CONTRACTOR.
14. COORDINATE ALL WORK ADJACENT TO BUILDING WITH BUILDING CONTRACTOR.
15. THE PROPERTY MANAGER WILL BE RESPONSIBLE FOR TIMELY SNOW REMOVAL FROM ALL PRIVATE SIDEWALKS, DRIVEWAYS, AND PARKING AREAS. SNOW REMOVAL WILL BE HAULED OFF-SITE AND LEGALLY DISPOSED OF WHEN SNOW BANKS EXCEED 3 FEET IN HEIGHT.
16. ALL DIMENSIONS ARE TO THE FACE OF CURB UNLESS OTHERWISE NOTED.
17. ALL CONDITIONS ON THIS PLAN SHALL REMAIN IN EFFECT IN PERPETUITY PURSUANT TO THE REQUIREMENTS OF THE SITE PLAN REVIEW REGULATIONS.
18. THIS SITE PLAN SHALL BE RECORDED IN THE ROCKINGHAM COUNTY REGISTRY OF DEEDS. ALL IMPROVEMENTS SHOWN ON THIS SITE PLAN SHALL BE CONSTRUCTED AND MAINTAINED IN ACCORDANCE WITH THE PLAN BY THE PROPERTY OWNER AND ALL FUTURE PROPERTY OWNERS. NO CHANGES SHALL BE MADE TO THIS SITE PLAN WITHOUT THE EXPRESS APPROVAL OF THE PORTSMOUTH PLANNING DIRECTOR.
19. THE APPLICANT SHALL HAVE A SITE SURVEY CONDUCTED BY A RADIO COMMUNICATIONS CARRIER APPROVED BY THE CITY'S COMMUNICATIONS DIVISION. THE RADIO COMMUNICATIONS CARRIER MUST BE FAMILIAR AND CONVERSANT WITH THE POLICE AND RADIO CONFIGURATION. IF THE SITE SURVEY INDICATES THAT IT IS NECESSARY TO INSTALL A SIGNAL REPEATER EITHER ON OR NEAR THE PROPOSED PROJECT, THOSE COSTS SHALL BE THE RESPONSIBILITY OF THE PROPERTY OWNER. THE OWNER SHALL COORDINATE WITH THE SUPERVISOR OF RADIO COMMUNICATIONS FOR THE CITY.
20. ALL TREES TO BE PLANTED ARE TO BE INSTALLED UNDER THE SUPERVISION OF THE CITY OF PORTSMOUTH DPW USING STANDARD INSTALLATION METHODS.
21. THE APPLICATION SHALL PREPARE A CONSTRUCTION MITIGATION AND MANAGEMENT PLAN (CMMP) FOR REVIEW AND APPROVAL BY THE CITY'S LEGAL AND PLANNING DEPARTMENTS.

NORTH MILL POND (TIDAL)

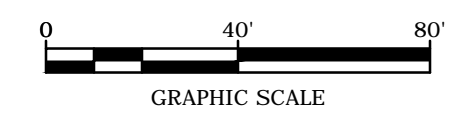
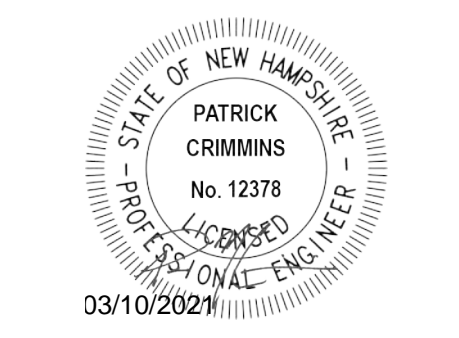
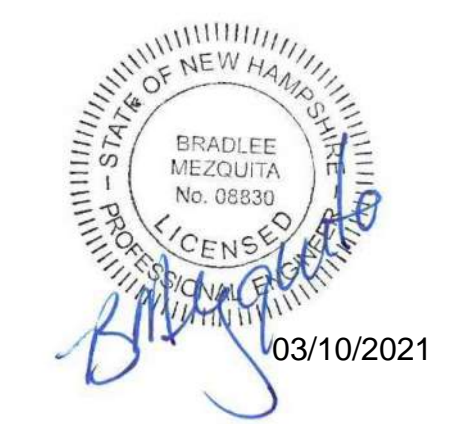
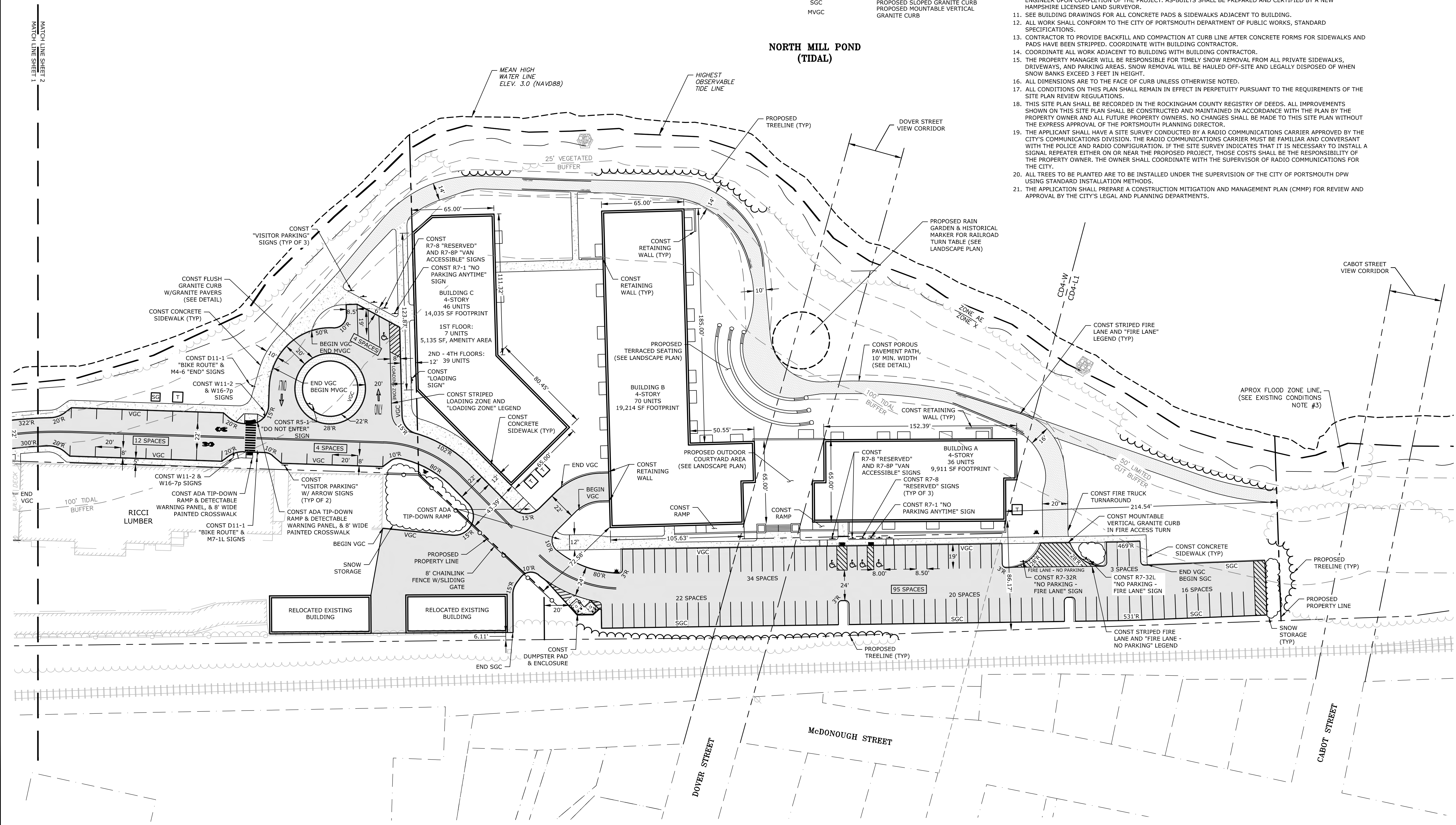

Proposed Multi-Family Development

Iron Horse Properties, LLC

105 Bartlett Street
Portsmouth,
New Hampshire

MARK	DATE	DESCRIPTION
I	3/10/2021	PB Submission
H	1/20/2021	TAC Resubmission
G	11/18/2020	TAC Resubmission
F	10/28/2020	Wetland CUP Resubmission
E	5/20/2020	TAC Resubmission
D	4/29/2020	Wetland CUP Submission
C	4/20/2020	TAC Submission
B	2/6/2020	Design Review Submission
A	1/2/2020	ZBA Submission

PROJECT NO:	C-0960-006
DATE:	April 20, 2020
FILE:	C-0960-006_C-SITE.DWG
DRAWN BY:	NAH
CHECKED:	PMC
APPROVED:	BML

SITE PLAN

SCALE: AS SHOWN

C-102.2

Last Saved: 3/10/2021
 Plotted On: Mar 10, 2021 1:58:48pm By: NAlamena
 Tighe & Bond, P.C. 105 Bartlett Street, Portsmouth, NH 03801-0006
 Figures Auto-CAD Sheet C-0960-006_C-SITE.dwg

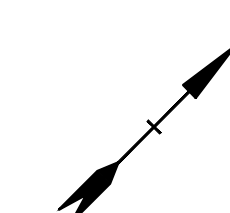

LEGEND

- PROPERTY LINE
- PROPOSED PROPERTY LINE
- PROPOSED EDGE OF PAVEMENT
- PROPOSED CURB
- PROPOSED BUILDING
- PROPOSED PAVEMENT SECTION
- PROPOSED POROUS PAVEMENT SECTION
- PROPOSED CONCRETE SIDEWALK
- PROPOSED BOLLARD
- BUILDING TYP
- COORD
- 30'R
- VGC
- SGC
- MVGC
- TYPICAL
- PROPOSED CURB RADIUS
- PROPOSED VERTICAL GRANITE CURB
- PROPOSED SLOPED GRANITE CURB
- PROPOSED MOUNTABLE VERTICAL GRANITE CURB

SITE NOTES:

1. STRIPE PARKING AREAS AS SHOWN, INCLUDING PARKING SPACES, STOP BARS, ADA SYMBOLS, PAINTED ISLANDS, CROSS WALKS, ARROWS, LEGENDS AND CENTERLINES SHALL BE THERMOPLASTIC MATERIAL. THERMOPLASTIC MATERIAL SHALL MEET THE REQUIREMENTS OF AASHTO M249. (ALL MARKINGS EXCEPT CENTERLINE AND MEDIAN ISLANDS TO BE CONSTRUCTED USING WHITE TRAFFIC PAINT. CENTERLINE AND MEDIAN ISLANDS TO BE CONSTRUCTED USING YELLOW TRAFFIC PAINT. ALL TRAFFIC PAINT SHALL MEET THE REQUIREMENTS OF AASHTO M248 TYPE "F").
2. ALL PAVEMENT MARKINGS AND SIGNS TO CONFORM TO "MANUAL ON UNIFORM TRAFFIC CONTROL DEVICES", "STANDARD ALPHABETS FOR HIGHWAY SIGNS AND PAVEMENT MARKINGS", AND THE AMERICANS WITH DISABILITIES ACT REQUIREMENTS, LATEST EDITIONS.
3. SEE DETAILS FOR PARKING STALL MARKINGS, ADA SYMBOLS, SIGNS AND SIGN POSTS.
4. CENTERLINES SHALL BE FOUR (4) INCH WIDE YELLOW LINES. STOP BARS SHALL BE EIGHTEEN (18) INCHES WIDE.
5. PAINTED ISLANDS SHALL BE FOUR (4) INCH WIDE DIAGONAL LINES AT 3'-0" O.C. BORDERED BY FOUR (4) INCH WIDE LINES.
6. THE CONTRACTOR SHALL EMPLOY A NEW HAMPSHIRE LICENSED LAND SURVEYOR TO DETERMINE ALL LINES AND GRADES.
7. CLEAN AND COAT VERTICAL FACE OF EXISTING PAVEMENT AT SAW CUT LINE WITH RS-1 EMULSION IMMEDIATELY PRIOR TO PLACING NEW BITUMINOUS CONCRETE.
8. ALL MATERIALS AND CONSTRUCTION SHALL CONFORM WITH APPLICABLE FEDERAL, STATE, AND LOCAL CODES & SPECIFICATIONS.
9. COORDINATE ALL WORK WITHIN PUBLIC RIGHT OF WAY WITH THE CITY OF PORTSMOUTH.
10. CONTRACTOR TO SUBMIT AS-BUILT PLANS IN DIGITAL FORMAT (.DWG AND .PDF FILES) ON DISK TO THE OWNER AND ENGINEER UPON COMPLETION OF THE PROJECT. AS-BUILTS SHALL BE PREPARED AND CERTIFIED BY A NEW HAMPSHIRE LICENSED LAND SURVEYOR.
11. SEE BUILDING DRAWINGS FOR ALL CONCRETE PADS & SIDEWALKS ADJACENT TO BUILDING.
12. ALL WORK SHALL CONFORM TO THE CITY OF PORTSMOUTH DEPARTMENT OF PUBLIC WORKS, STANDARD SPECIFICATIONS.
13. CONTRACTOR TO PROVIDE BACKFILL AND COMPACTION AT CURB LINE AFTER CONCRETE FORMS FOR SIDEWALKS AND PADS HAVE BEEN STRIPPED. COORDINATE WITH BUILDING CONTRACTOR.
14. COORDINATE ALL WORK ADJACENT TO BUILDING WITH BUILDING CONTRACTOR.
15. THE PROPERTY MANAGER WILL BE RESPONSIBLE FOR TIMELY SNOW REMOVAL FROM ALL PRIVATE SIDEWALKS, DRIVEWAYS, AND PARKING AREAS. SNOW REMOVAL WILL BE HAULED OFF-SITE AND LEGALLY DISPOSED OF WHEN SNOW BANKS EXCEED 3 FEET IN HEIGHT.
16. ALL DIMENSIONS ARE TO THE FACE OF CURB UNLESS OTHERWISE NOTED.
17. ALL CONDITIONS ON THIS PLAN SHALL REMAIN IN EFFECT IN PERPETUITY PURSUANT TO THE REQUIREMENTS OF THE SITE PLAN REVIEW REGULATIONS.
18. THIS SITE PLAN SHALL BE RECORDED IN THE ROCKINGHAM COUNTY REGISTRY OF DEEDS. ALL IMPROVEMENTS SHOWN ON THIS SITE PLAN SHALL BE CONSTRUCTED AND MAINTAINED IN ACCORDANCE WITH THE PLAN BY THE PROPERTY OWNER AND ALL FUTURE PROPERTY OWNERS. NO CHANGES SHALL BE MADE TO THIS SITE PLAN WITHOUT THE EXPRESS APPROVAL OF THE PORTSMOUTH PLANNING DIRECTOR.
19. THE APPLICANT SHALL HAVE A SITE SURVEY CONDUCTED BY A RADIO COMMUNICATIONS CARRIER APPROVED BY THE CITY'S COMMUNICATIONS DIVISION. THE RADIO COMMUNICATIONS CARRIER MUST BE FAMILIAR AND CONVERSANT WITH THE POLICE AND RADIO CONFIGURATION. IF THE SITE SURVEY INDICATES THAT IT IS NECESSARY TO INSTALL A SIGNAL REPEATER EITHER ON OR NEAR THE PROPOSED PROJECT, THESE COSTS SHALL BE THE RESPONSIBILITY OF THE PROPERTY OWNER. THE OWNER SHALL COORDINATE WITH THE SUPERVISOR OF RADIO COMMUNICATIONS FOR THE CITY.
20. ALL TREES TO BE PLANTED ARE TO BE INSTALLED UNDER THE SUPERVISION OF THE CITY OF PORTSMOUTH DPW USING STANDARD INSTALLATION METHODS.
21. THE APPLICATION SHALL PREPARE A CONSTRUCTION MITIGATION AND MANAGEMENT PLAN (CMMP) FOR REVIEW AND APPROVAL BY THE CITY'S LEGAL AND PLANNING DEPARTMENTS.

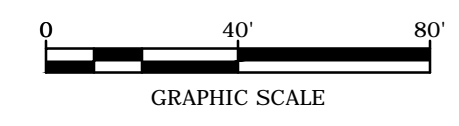
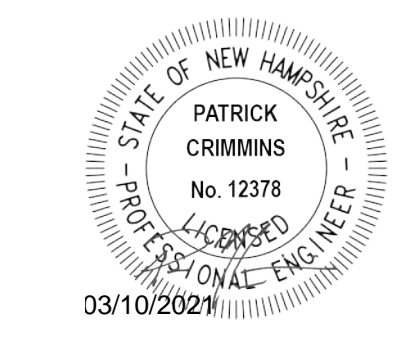
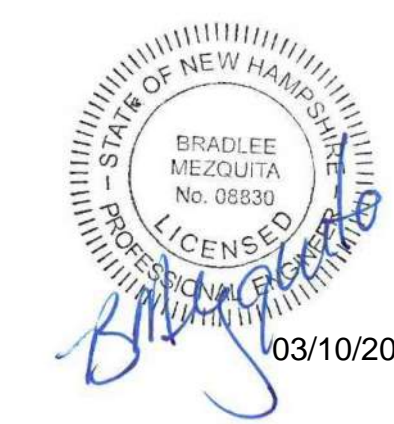

NORTH MILL POND (TIDAL)

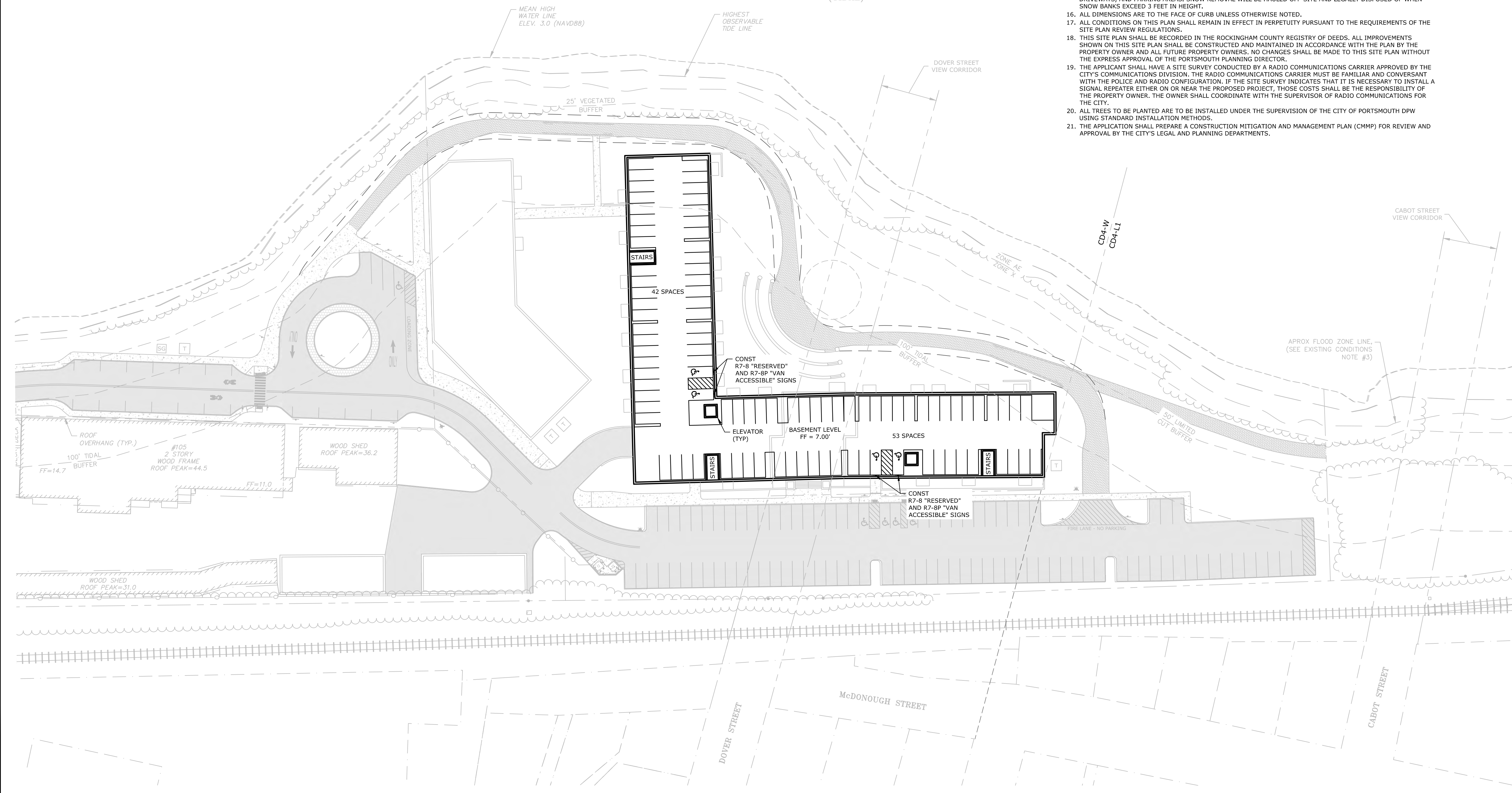

Proposed Multi-Family Development

Iron Horse Properties, LLC

105 Bartlett Street
Portsmouth,
New Hampshire

I	3/10/2021	PB Submission
H	1/20/2021	TAC Resubmission
G	11/18/2020	TAC Resubmission
F	10/28/2020	Wetland CUP Resubmission
E	5/20/2020	TAC Resubmission
D	4/29/2020	Wetland CUP Submission
C	4/20/2020	TAC Submission
B	2/6/2020	Design Review Submission
A	1/2/2020	ZBA Submission
MARK	DATE	DESCRIPTION

PROJECT NO:	C-0960-006
DATE:	April 20, 2020
FILE:	C-0960-006_C-SITE.DWG
DRAWN BY:	NAH
CHECKED:	PMC
APPROVED:	BML

BASEMENT LEVEL SITE PLAN

SCALE: AS SHOWN

C-102.3

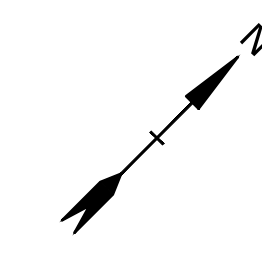

GRADING AND DRAINAGE NOTES:

1. COMPACTION REQUIREMENTS:
BELOW PAVED OR CONCRETE AREAS 95%
TRENCH BEDDING MATERIAL AND SAND BLANKET BACKFILL 95%
BELOW LOAM AND SEED AREAS 90%
2. ALL PERCENTAGES OF COMPACTION SHALL BE OF THE MAXIMUM DRY DENSITY AT THE OPTIMUM MOISTURE CONTENT AS DETERMINED AND CONTROLLED IN ACCORDANCE WITH ASTM D-1557, METHOD C FIELD DENSITY TESTS SHALL BE MADE IN ACCORDANCE WITH ASTM D-1556 OR ASTM-2922.
3. ALL STORM DRAINAGE PIPES SHALL BE HIGH DENSITY POLYETHYLENE (HANCOR HI-Q, ADS N-12 OR EQUAL), UNLESS OTHERWISE SPECIFIED.
4. SEE UTILITY PLAN FOR ALL SITE UTILITY INFORMATION.
5. ADJUST ALL MANHOLES, CATCH BASINS, CURB BOXES, ETC. WITHIN LIMITS OF WORK TO FINISH GRADE.
6. CONTRACTOR SHALL PROVIDE A FINISH PAVEMENT SURFACE AND LAWN AREAS FREE OF LOW SPOTS AND PONDING AREAS. CRITICAL AREAS INCLUDE BUILDING ENTRANCES, EXITS, RAMPS AND LOADING DOCK AREAS ADJACENT TO THE BUILDING.
7. CONTRACTOR SHALL THOROUGHLY CLEAN ALL CATCH BASINS AND DRAIN LINES, WITHIN THE LIMIT OF WORK, OF SEDIMENT IMMEDIATELY UPON COMPLETION OF CONSTRUCTION.
8. ALL MATERIALS AND CONSTRUCTION SHALL CONFORM WITH APPLICABLE FEDERAL, STATE AND LOCAL CODES.
9. ALL DISTURBED AREAS NOT TO BE PAVED OR OTHERWISE TREATED SHALL RECEIVE 6" LOAM, SEED FERTILIZER AND MULCH.
10. ALL STORM DRAIN CONSTRUCTION SHALL BE IN ACCORDANCE WITH THE NHDOT STANDARD SPECIFICATIONS FOR HIGHWAYS AND BRIDGES, LATEST EDITION.
11. ALL PROPOSED CATCH BASINS SHALL BE EQUIPPED WITH OIL/GAS SEPARATOR HOODS AND 4' SUMPS.
12. ALL WORK SHALL CONFORM TO THE CITY OF PORTSMOUTH DEPARTMENT OF PUBLIC WORKS, STANDARD SPECIFICATIONS AND WITH THE STATE OF NEW HAMPSHIRE DEPARTMENT OF TRANSPORTATION, "STANDARD SPECIFICATIONS OF ROAD AND BRIDGE CONSTRUCTION", CURRENT EDITION.
13. CONTRACTOR TO SUBMIT AS-BUILT PLANS IN DIGITAL FORMAT (.DWG AND .PDF FILES) ON DISK TO THE OWNER AND ENGINEER UPON COMPLETION OF THE PROJECT. AS-BUILTS SHALL BE PREPARED AND CERTIFIED BY A NEW HAMPSHIRE LICENSED LAND SURVEYOR.
14. SEE EXISTING CONDITIONS PLAN FOR BENCH MARK INFORMATION.
15. AREAS DISTURBED WITHIN THE 25' VEGETATED BUFFER BY HEADWALLS AND CULVERT CONSTRUCTION SHALL BE LOAMED, SEEDED WITH NEW ENGLAND WILDLIFE AND CONSERVATION SEED MIX AND STABILIZED WITH JUTE MESH.

LEGEND

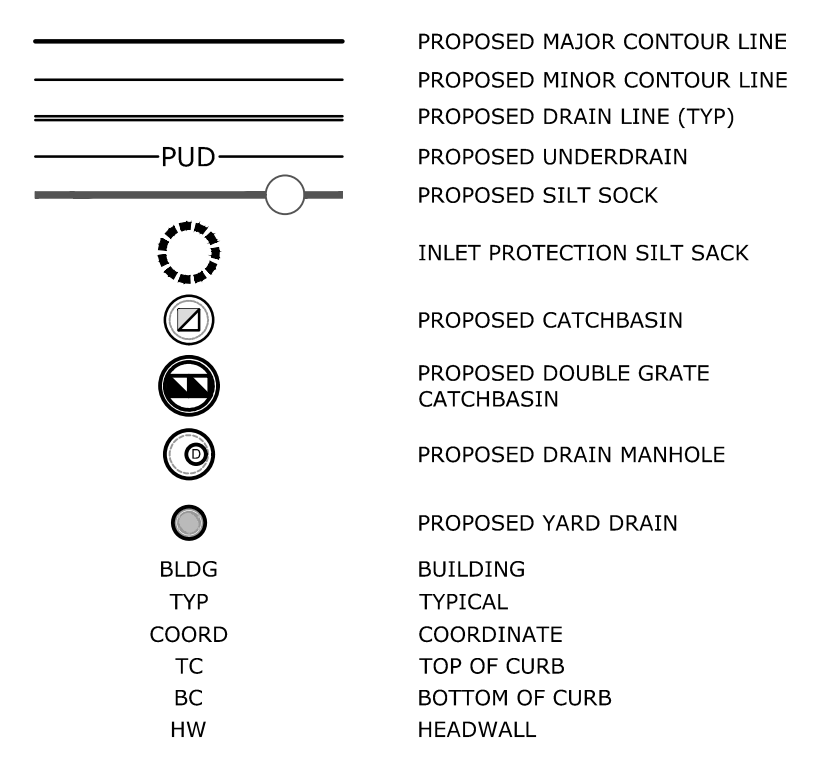

DRAINAGE STRUCTURE TABLE

CB1242 RIM=9.30 INV.OUT=5.80 SW	PCB3 RIM=8.40 INV.OUT=5.50 NW	PCB9 RIM=12.65 INV.OUT=8.65 NW	PDMH3 RIM=10.65 INV.IN=4.30 SE INV.OUT=4.20 NE	PDMH9 RIM=14.05 INV.IN=4.60 SE INV.OUT=4.60 NW	PDMH15 RIM=9.70 INV.IN=5.60 NE INV.OUT=5.50 NW	PYD1 RIM=12.50 INV.OUT=7.70 N
CB1243 RIM=9.55 INV.IN=6.65 NW INV.OUT=6.55 SE	PCB4 RIM=8.55 INV.OUT=6.10 NW	PCB10 RIM=12.15 INV.OUT=8.60 NW	PDMH4 RIM=11.70 INV.IN=3.45 SW INV.IN=4.30 NE INV.OUT=3.35 NW	PDMH10 RIM=13.00 INV.IN=6.10 E INV.IN=5.00 W INV.IN=3.80 SE INV.OUT=3.70 N	PDMH16 RIM=15.50 INV.IN=10.10 SW INV.IN=11.50 NE INV.OUT=10.00 NW	PYD2 RIM=12.30 INV.IN=7.50 S INV.OUT=7.40 NE
CB1244 RIM=10.00 INV.OUT=6.85 SW	PCB5 RIM=9.60 INV.OUT=6.10 NW	PCB11 RIM=8.60 INV.OUT=5.80 NE	PDMH5 RIM=11.30 INV.IN=5.05 NE INV.OUT=4.95 SW	PDMH11 RIM=8.75 INV.IN=5.35 SW INV.IN=5.35 N INV.OUT=5.35 NE	PDMH17 RIM=16.30 INV.IN=9.00 SE INV.IN=6.00 SW INV.OUT=5.80 NW	PYD3 RIM=11.00 INV.IN=7.10 SW INV.IN=8.00 NW INV.OUT=7.00 NE
CB1264 RIM=9.50 INV.OUT=6.50 NE	PCB6 RIM=9.80 INV.OUT=6.30 SW	PCB12 RIM=8.60 INV.OUT=5.45 S	PDMH6 RIM=9.85 INV.IN=6.00 NE INV.IN=5.20 S INV.IN=5.20 SE INV.OUT=5.10 NE	PDMH12 RIM=9.60 INV.IN=5.40 SE INV.IN=5.40 NE INV.IN=4.70 SW INV.OUT=4.65 NW	PDMH18 RIM=11.80 INV.OUT=8.88 SE	PYD4 RIM=13.00 INV.OUT=10.70 SE
PCB1 RIM=8.50 INV.OUT=5.30 E	PCB7 RIM=10.00 INV.OUT=7.00 NE	PDMH1 RIM=8.75 INV.IN=5.20 W INV.IN=5.20 S INV.IN=5.20 SE INV.OUT=5.10 NE	PDMH7 RIM=12.37 INV.IN=6.60 NW INV.IN=5.00 SW INV.IN=6.60 W INV.OUT=6.50 SE	PDMH13 RIM=10.00 INV.IN=6.45 NE INV.IN=6.45 NW INV.OUT=6.35 SW	PDMH19 RIM=11.90 INV.OUT=8.88 N	PYD5 RIM=11.50 INV.IN=7.00 W INV.IN=7.15 S INV.OUT=7.05 E
PCB2 RIM=8.45 INV.OUT=5.30 N	PCB8 RIM=10.75 INV.OUT=7.50 NW	PDMH2 RIM=9.90 INV.IN=5.00 SW INV.IN=5.00 SE INV.OUT=4.90 NE	PDMH8 RIM=11.35 INV.IN=6.25 NW INV.IN=6.25 SE INV.IN=10.50 SW INV.IN=10.50 NW INV.OUT=6.00 NE	PDMH14 RIM=13.50 INV.IN=10.50 SW INV.IN=10.50 NW INV.OUT=10.40 NE	POS1 RIM=10.50 INV.OUT=7.15 E	

EROSION CONTROL NOTES:

1. INSTALL EROSION CONTROL BARRIERS AS SHOWN AS FIRST ORDER OF WORK.
2. SEE GENERAL EROSION CONTROL NOTES ON "EROSION CONTROL NOTES & DETAILS SHEET".
3. PROVIDE INLET PROTECTION AROUND ALL EXISTING AND PROPOSED CATCH BASIN INLETS WITHIN THE WORK LIMITS AS WELL AS CATCH BASINS/CURB INLETS THAT RECEIVE RUNOFF FROM CONSTRUCTION ACTIVITIES. MAINTAIN FOR THE DURATION OF THE PROJECT.
4. INSTALL STABILIZED CONSTRUCTION EXIT(S).
5. INSPECT INLET PROTECTION AND PERIMETER EROSION CONTROL MEASURES DAILY AND AFTER EACH RAIN STORM OF 0.25 INCH OR GREATER. REPAIR/MODIFY PROTECTION AS NECESSARY TO MAXIMIZE EFFICIENCY OF FILTER. REPLACE ALL FILTERS WHEN SEDIMENT IS 1/3 THE FILTER HEIGHT.
6. ALL DISTURBED AREAS NOT TO BE PAVED OR OTHERWISE TREATED SHALL RECEIVE 6" LOAM, SEED, FERTILIZER AND MULCH.
7. CONSTRUCT EROSION CONTROL BLANKET ON ALL SLOPES STEEPER THAN 3:1.
8. PRIOR TO ANY WORK OR SOIL DISTURBANCE COMMENCING ON THE SUBJECT PROPERTY, INCLUDING MOVING OF EARTH, THE APPLICANT SHALL INSTALL ALL EROSION AND SILTATION MITIGATION AND CONTROL MEASURES AS REQUIRED BY STATE AND LOCAL PERMITS AND APPROVALS.
9. CONTRACTOR SHALL BE RESPONSIBLE TO CONTROL DUST AND WIND EROSION THROUGHOUT THE CONSTRUCTION PERIOD. DUST CONTROL MEASURES SHALL INCLUDE, BUT ARE NOT LIMITED TO, SPRINKLING WATER ON UNSTABLE SOILS SUBJECT TO ARID CONDITIONS.
10. THE CONTRACTOR SHALL REMOVE AND PROPERLY DISPOSE OF ALL TEMPORARY EROSION CONTROL DEVICES UPON COMPLETION OF CONSTRUCTION.
11. ALL CATCH BASIN SUMPS AND PIPING SHALL BE THOROUGHLY CLEANED TO REMOVE ALL SEDIMENT AND DEBRIS AFTER THE PROJECT HAS BEEN FULLY PAVED.
12. TEMPORARY SOIL STOCKPILE SHALL BE SURROUNDED WITH PERIMETER CONTROLS AND SHALL BE STABILIZED BY TEMPORARY EROSION CONTROL SEEDING. STOCKPILE AREAS TO BE LOCATED AS FAR AS POSSIBLE FROM THE DELINEATED EDGE OF WETLANDS.
13. SAFETY FENCING SHALL BE PROVIDED AROUND STOCKPILES OVER 10 FT.
14. CONCRETE TRUCKS WILL BE REQUIRED TO WASH OUT (IF NECESSARY) SHOOTS ONLY WITHIN AREAS WHERE CONCRETE HAS BEEN PLACED. NO OTHER WASH OUT WILL BE ALLOWED.
15. ALL CONDITIONS ON THIS PLAN SHALL REMAIN IN EFFECT IN PERPETUITY PURSUANT TO THE REQUIREMENTS OF THE SITE PLAN REVIEW REGULATIONS.

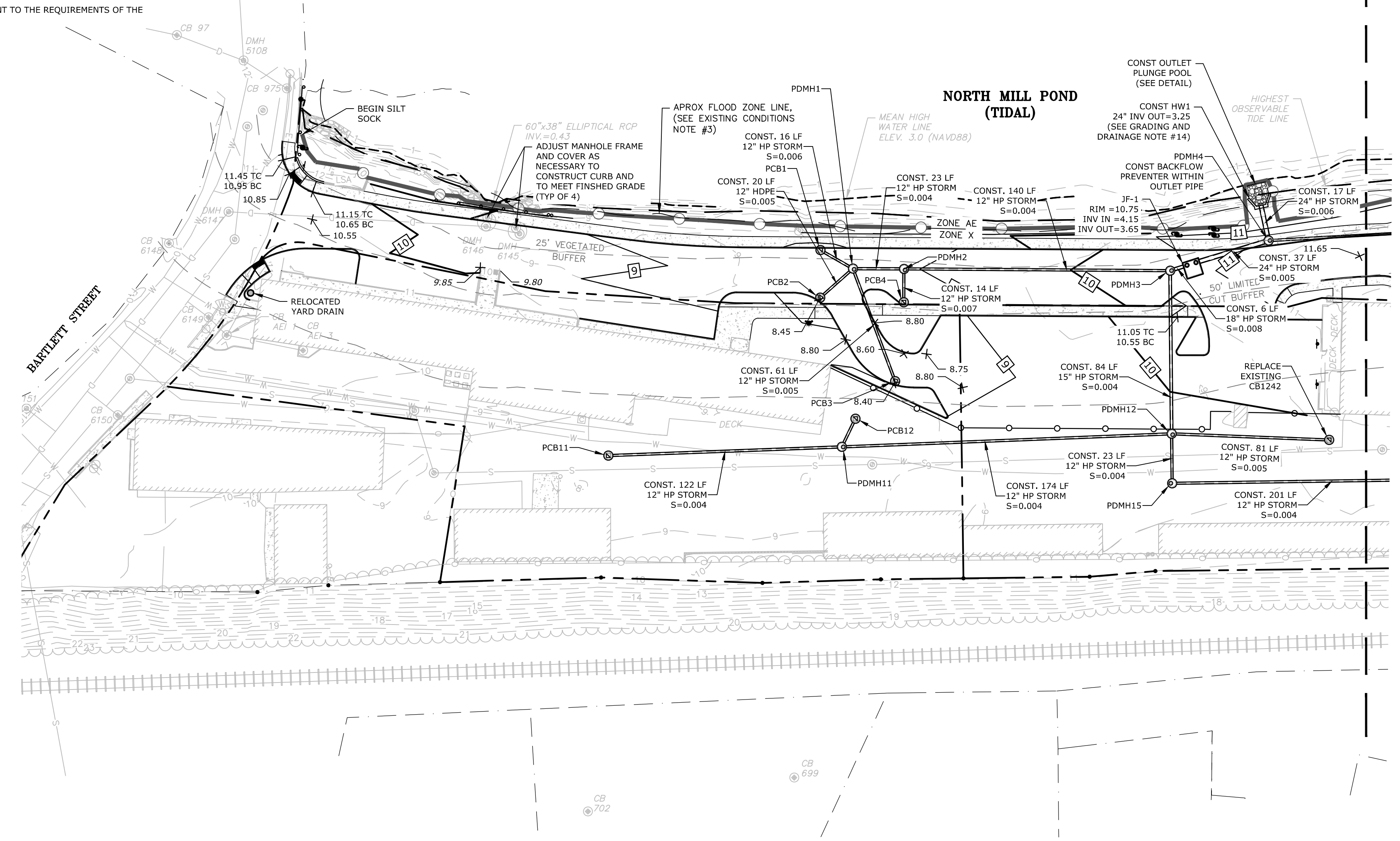

MATCH LINE SHEET 2

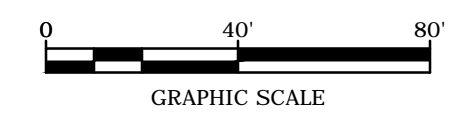
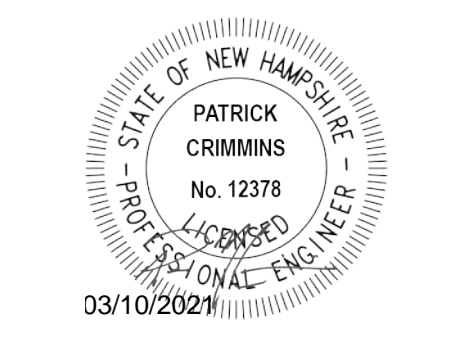
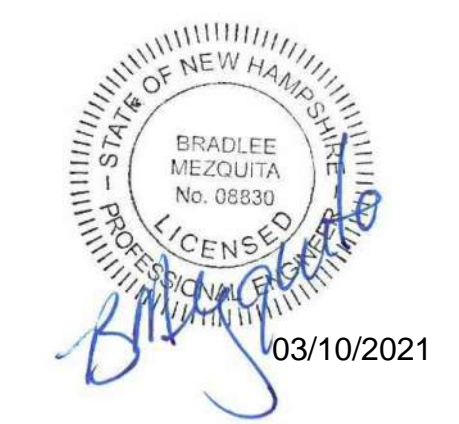

Proposed Multi-Family Development

Iron Horse Properties, LLC

**105 Bartlett Street
Portsmouth,
New Hampshire**

I	3/10/2021	PB Submission
H	1/20/2021	TAC Resubmission
G	11/18/2020	TAC Resubmission
F	10/28/2020	Wetland CUP Resubmission
E	5/20/2020	TAC Resubmission
D	4/29/2020	Wetland CUP Submission
C	4/20/2020	TAC Submission
B	2/6/2020	Design Review Submission
A	1/2/2020	ZBA Submission
MARK	DATE	DESCRIPTION

PROJECT NO:	C-0960-006
DATE:	April 20, 2020
FILE:	C-0960-006_C-SITE.DWG
DRAWN BY:	NAH
CHECKED:	PMC
APPROVED:	BML

GRADING, DRAINAGE, AND EROSION CONTROL PLAN

SCALE: AS SHOWN

C-103.1

Last Saved: 3/10/2021
Plotted On: Mar 10, 2021 1:48:48pm By: N.Hansman
Tighe & Bond, Inc. C:\p0960-006 105 Bartlett Street Drawings - Figures AutoCAD Sheet C-0960-006 C-SITE.dwg

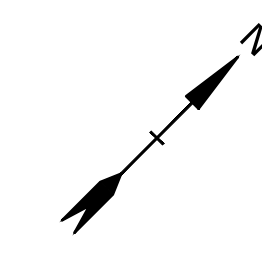

UTILITY NOTES:

- THE LOCATIONS OF EXISTING UNDERGROUND UTILITIES ARE APPROXIMATE AND THE LOCATIONS ARE NOT GUARANTEED BY THE OWNER OR ENGINEER. IT IS THE CONTRACTOR'S RESPONSIBILITY TO LOCATE ALL UTILITIES, ANTICIPATE CONFLICTS, REPAIR EXISTING UTILITIES, AND RELOCATE EXISTING UTILITIES TO COMPLETE THE WORK AT NO ADDITIONAL COST TO THE OWNER.
- COORDINATE ALL UTILITY WORK WITH APPROPRIATE UTILITY COMPANY.
 - NATURAL GAS - UNITIL
 - WATER/SEWER - CITY OF PORTSMOUTH
 - ELECTRIC - EVERSOURCE
 - COMMUNICATIONS - CONSOLIDATED COMMUNICATIONS & COMCAST
- SEE EXISTING CONDITIONS PLAN FOR BENCHMARK INFORMATION.
- SEE GRADING, DRAINAGE & EROSION CONTROL PLAN FOR PROPOSED GRADING AND EROSION CONTROL MEASURES.
- THE APPLICANT SHALL COORDINATE WITH THE CITY'S CONSULTANT TO COMPLETE A WATER CAPACITY ANALYSIS USING THE CITY'S CAPACITY MODELING AND SHALL MODIFY THE WATER SERVICE DESIGN AS REQUIRED. THE PRIVATE WATER LINE THAT CURRENTLY FEEDS THE DEVELOPMENT LOT SHALL BE EITHER REPLACED OR ABANDONED DEPENDING ON THE OUTCOME OF THE STUDY. ALL MODIFICATIONS SHALL BE REVIEWED AND APPROVED BY THE DPW AND THE FIRE DEPARTMENT.
- PROPOSED WATER MAIN WILL REMAIN PRIVATE AND A PRIVATE WATER MAIN MAINTENANCE AGREEMENT WITH THE CITY IS REQUIRED.
- ALL WATER MAIN INSTALLATIONS SHALL BE CLASS 52, CEMENT LINED DUCTILE IRON PIPE.
- ALL WATER MAIN INSTALLATIONS SHALL BE PRESSURE TESTED AND CHLORINATED AFTER CONSTRUCTION PRIOR TO ACTIVATING THE SYSTEM. CONTRACTOR SHALL COORDINATE CHLORINATION AND TESTING WITH THE CITY OF PORTSMOUTH WATER DEPARTMENT.
- ALL SEWER PIPE SHALL BE PVC SDR 35 UNLESS OTHERWISE STATED.
- COORDINATE ALL WORK WITHIN PUBLIC RIGHT OF WAYS WITH THE CITY OF PORTSMOUTH.
- CONTRACTOR SHALL MAINTAIN UTILITY SERVICES TO ABUTTING PROPERTIES THROUGHOUT CONSTRUCTION.
- CONNECTION TO EXISTING WATER MAIN SHALL BE CONSTRUCTED TO CITY OF PORTSMOUTH STANDARDS.
- EXISTING UTILITIES TO BE REMOVED SHALL BE CAPPED AT THE MAIN AND MEET THE DEPARTMENT OF PUBLIC WORKS STANDARDS FOR CAPPING OF WATER AND SEWER SERVICES.
- ALL ELECTRICAL MATERIAL WORKMANSHIP SHALL CONFORM TO THE NATIONAL ELECTRIC CODE, LATEST EDITION, AND ALL APPLICABLE STATE AND LOCAL CODES.
- THE EXACT LOCATION OF NEW UTILITY SERVICES AND CONNECTIONS SHALL BE COORDINATED WITH THE BUILDING DRAWINGS AND THE APPLICABLE UTILITY COMPANIES.
- ADJUST ALL MANHOLES, CATCH BASINS, CURB BOXES, ETC. WITHIN LIMITS OF WORK TO FINISH GRADE.
- ALL UNDERGROUND CONDUITS SHALL HAVE NYLON PULL ROPES TO FACILITATE PULLING CABLES.
- THE CONTRACTOR SHALL OBTAIN, PAY FOR, AND COMPLY WITH ALL REQUIRED PERMITS, ARRANGE FOR ALL INSPECTIONS, AND SUBMIT COPIES OF ACCEPTANCE CERTIFICATES TO THE OWNER PRIOR TO THE COMPLETION OF THIS PROJECT.
- THE CONTRACTOR SHALL PROVIDE AND INSTALL ALL MANHOLES, BOXES, FITTINGS, CONNECTORS, COVER PLATES, AND OTHER MISCELLANEOUS ITEMS NOT NECESSARILY DETAILED ON THESE DRAWINGS TO RENDER INSTALLATION OF UTILITIES COMPLETE AND OPERATIONAL.
- CONTRACTOR SHALL PROVIDE EXCAVATION, BEDDING, BACKFILL AND COMPACTION FOR NATURAL GAS SERVICES.
- A 10-FOOT MINIMUM EDGE TO EDGE HORIZONTAL SEPARATION SHALL BE PROVIDED BETWEEN ALL WATER AND SANITARY SEWER LINES. AN 18-INCH MINIMUM OUTSIDE TO OUTSIDE VERTICAL SEPARATION SHALL BE PROVIDED AT ALL WATER/SANITARY SEWER CROSSINGS.
- THE CONTRACTOR SHALL CONTACT "DIG-SAFE" 72 HOURS PRIOR TO COMMENCING CONSTRUCTION. THE CONTRACTOR SHALL HAVE THE "DIG-SAFE" NUMBER ON SITE AT ALL TIMES.
- CONTRACTOR TO SUBMIT AS-BUILT PLANS ON REPRODUCIBLE MYLARS AND IN DIGITAL FORMAT (.DWG FILES) TO THE OWNER AND ENGINEER UPON COMPLETION OF THE PROJECT. AS-BUILTS SHALL BE PREPARED AND CERTIFIED BY A NEW HAMPSHIRE LICENSED LAND SURVEYOR OR PROFESSIONAL ENGINEER.
- SAW CUT AND REMOVE PAVEMENT AND CONSTRUCT PAVEMENT TRENCH PATCH FOR ALL PROPOSED UTILITIES LOCATED IN EXISTING PAVEMENT AREAS TO REMAIN
- HYDRANTS, GATE VALVES, FITTINGS, ETC. SHALL MEET THE REQUIREMENTS OF THE CITY OF PORTSMOUTH.
- COORDINATE TESTING OF SEWER CONSTRUCTION WITH THE CITY OF PORTSMOUTH.
- ALL SEWER PIPE WITH LESS THAN 6' OF COVER IN PAVED AREAS OR LESS THAN 4' OF COVER IN UNPAVED AREAS SHALL BE INSULATED.
- CONTRACTOR SHALL COORDINATE ALL ELECTRIC WORK INCLUDING BUT NOT LIMITED TO: CONDUIT CONSTRUCTION, MANHOLE CONSTRUCTION, UTILITY POLE CONSTRUCTION, OVERHEAD WIRE RELOCATION, AND TRANSFORMER CONSTRUCTION WITH POWER COMPANY.
- CONTRACTOR SHALL PHASE UTILITY CONSTRUCTION, PARTICULARLY WATER MAIN AND GAS MAIN CONSTRUCTION AS TO MAINTAIN CONTINUOUS SERVICE TO ABUTTING PROPERTIES. CONTRACTOR SHALL COORDINATE TEMPORARY SERVICES TO ABUTTERS WITH THE UTILITY COMPANY AND AFFECTED ABUTTER.
- SITE LIGHTING SPECIFICATIONS, CONDUIT LAYOUT AND CIRCUITRY FOR PROPOSED SITE LIGHTING AND SIGN ILLUMINATION SHALL BE PROVIDED BY THE PROJECT ELECTRICAL ENGINEER.
- CONTRACTOR SHALL CONSTRUCT ALL UTILITIES AND DRAINS TO WITHIN 10' OF THE FOUNDATION WALLS AND CONNECT THESE TO SERVICE STUDS FROM THE BUILDING.
- ALL CONDITIONS ON THIS PLAN SHALL REMAIN IN EFFECT IN PERPETUITY PURSUANT TO THE REQUIREMENTS OF THE SITE PLAN REVIEW REGULATIONS.

LEGEND

- EXISTING STORM DRAIN
- EXISTING SANITARY SEWER
- EXISTING WATER
- EXISTING GAS
- EXISTING UNDERGROUND ELECTRIC
- EXISTING OVERHEAD UTILITY
- PROPOSED STORM DRAIN
- PROPOSED SANITARY SEWER
- PROPOSED WATER
- PROPOSED GAS
- PROPOSED UNDERGROUND ELECTRIC
- PROPOSED UNDERGROUND TELECOMMUNICATION
- EXISTING CATCHBASIN
- EXISTING DRAIN MANHOLE
- EXISTING SEWER MANHOLE
- EXISTING HYDRANT
- EXISTING WATER VALVE
- EXISTING WATER SHUT OFF
- EXISTING GAS VALVE
- EXISTING GAS SHUT OFF
- EXISTING UTILITY POLE
- EXISTING ELECTRIC MANHOLE
- EXISTING TELEPHONE MANHOLE
- PROPOSED CATCHBASIN
- PROPOSED DRAIN MANHOLE
- PROPOSED SEWER MANHOLE
- PROPOSED WATER VALVE
- PROPOSED HYDRANT
- PROPOSED GAS VALVE
- PROPOSED LIGHT POLE BASE
- BLDG
- TYP
- COORD
- VIF

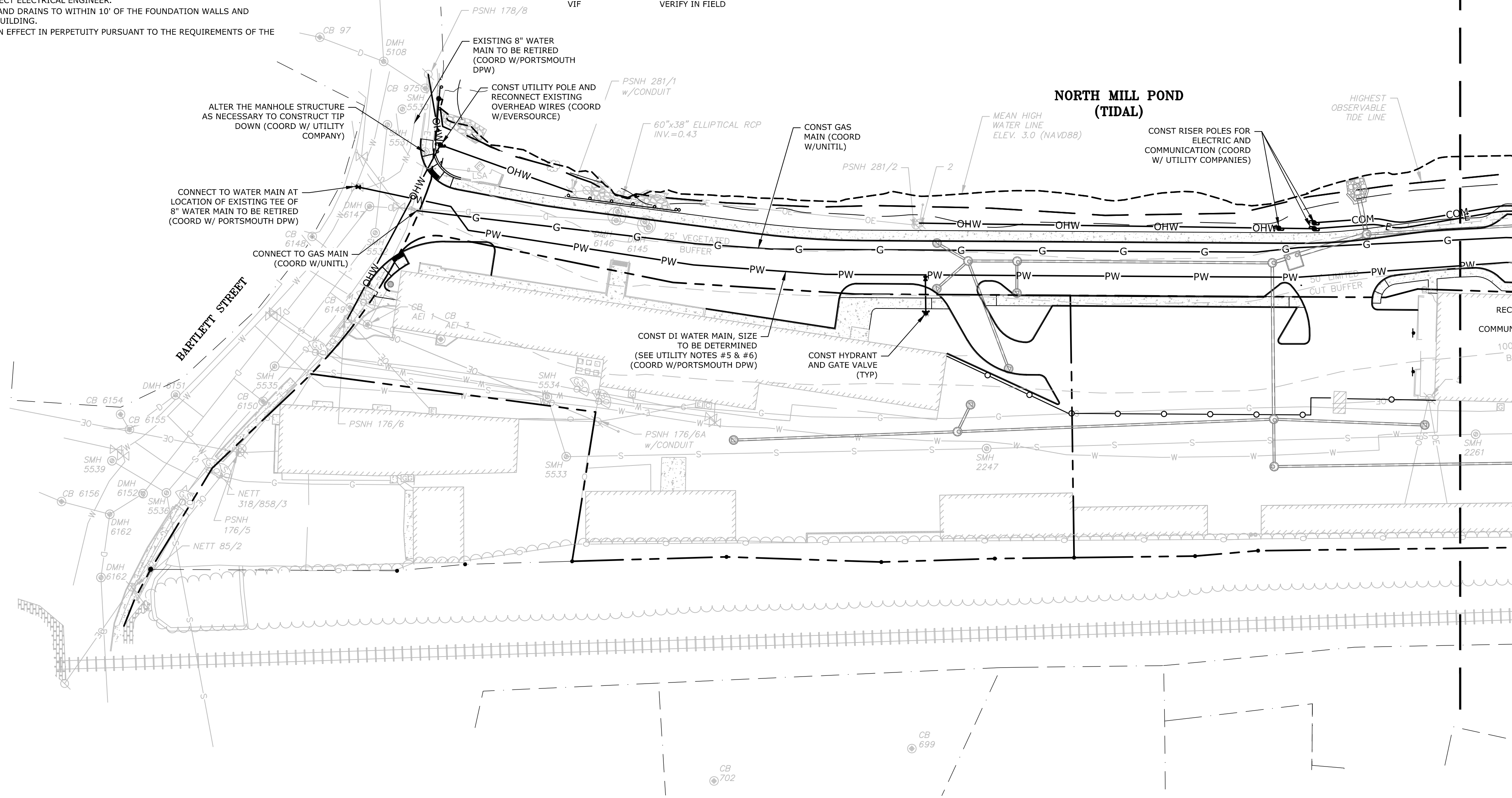

MATCH LINE SHEET 2
MATCH LINE SHEET 1

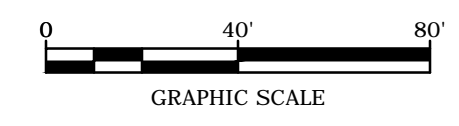
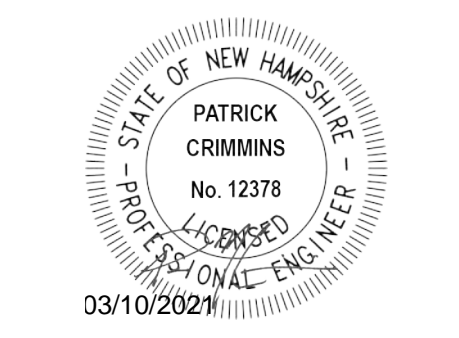
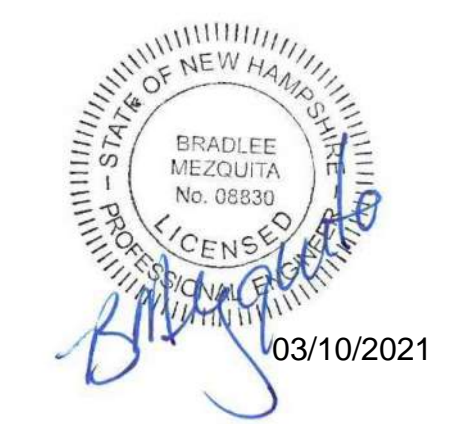

Proposed Multi-Family Development

Iron Horse Properties, LLC

105 Bartlett Street
Portsmouth,
New Hampshire

MARK	DATE	DESCRIPTION
I	3/10/2021	PB Submission
H	1/20/2021	TAC Resubmission
G	11/18/2020	TAC Resubmission
F	10/28/2020	Wetland CUP Resubmission
E	5/20/2020	TAC Resubmission
D	4/29/2020	Wetland CUP Submission
C	4/20/2020	TAC Submission
B	2/6/2020	Design Review Submission
A	1/2/2020	ZBA Submission

PROJECT NO:	C-0960-006
DATE:	April 20, 2020
FILE:	C-0960-006_C-SITE.DWG
DRAWN BY:	NAH
CHECKED:	PMC
APPROVED:	BML

UTILITIES PLAN

SCALE: AS SHOWN

C-104.1

LEGEND

- D ——— EXISTING STORM DRAIN
- S ——— EXISTING SANITARY SEWER
- W ——— EXISTING WATER
- G ——— EXISTING GAS
- E ——— EXISTING UNDERGROUND ELECTRIC
- OE ——— EXISTING OVERHEAD UTILITY
- SS ——— PROPOSED STORM DRAIN
- PW ——— PROPOSED SANITARY SEWER
- G ——— PROPOSED WATER
- E ——— PROPOSED GAS
- COM ——— PROPOSED UNDERGROUND ELECTRIC
- COM ——— PROPOSED UNDERGROUND TELECOMMUNICATION
- ⊕ EXISTING CATCHBASIN
- ⊕ EXISTING DRAIN MANHOLE
- ⊕ EXISTING SEWER MANHOLE
- ⊕ EXISTING HYDRANT
- ⊕ EXISTING WATER VALVE
- ⊕ EXISTING WATER SHUT OFF
- ⊕ EXISTING GAS VALVE
- ⊕ EXISTING GAS SHUT OFF
- ⊕ EXISTING UTILITY POLE
- ⊕ EXISTING ELECTRIC MANHOLE
- ⊕ EXISTING TELEPHONE MANHOLE
- ⊕ PROPOSED CATCHBASIN
- ⊕ PROPOSED DRAIN MANHOLE
- ⊕ PROPOSED SEWER MANHOLE
- ⊕ PROPOSED WATER VALVE
- ⊕ PROPOSED HYDRANT
- ⊕ PROPOSED GAS VALVE
- ⊕ PROPOSED LIGHT POLE BASE
- BLDG TYP COORD VIF

UTILITY NOTES:

1. THE LOCATIONS OF EXISTING UNDERGROUND UTILITIES ARE APPROXIMATE AND THE LOCATIONS ARE NOT GUARANTEED BY THE OWNER OR ENGINEER. IT IS THE CONTRACTOR'S RESPONSIBILITY TO LOCATE ALL UTILITIES, ANTICIPATE CONFLICTS, REPAIR EXISTING UTILITIES, AND RELOCATE EXISTING UTILITIES REQUIRED TO COMPLETE THE WORK AT NO ADDITIONAL COST TO THE OWNER.
2. COORDINATE ALL UTILITY WORK WITH APPROPRIATE UTILITY COMPANY.
 - NATURAL GAS - UNITIL
 - WATER/SEWER - CITY OF PORTSMOUTH
 - ELECTRIC - EVERSOURCE
 - COMMUNICATIONS - CONSOLIDATED COMMUNICATIONS & COMCAST
3. SEE EXISTING CONDITIONS PLAN FOR BENCHMARK INFORMATION.
4. SEE GRADING, DRAINAGE & EROSION CONTROL PLAN FOR PROPOSED GRADING AND EROSION CONTROL MEASURES.
5. THE APPLICANT SHALL COORDINATE WITH THE CITY'S CONSULTANT TO COMPLETE A WATER CAPACITY ANALYSIS USING THE CITY'S CAPACITY MODELING AND SHALL MODIFY THE WATER SERVICE DESIGN AS REQUIRED. THE PRIVATE WATER LINE THAT CURRENTLY FEEDS THE DEVELOPMENT LOT SHALL BE EITHER REPLACED OR ABANDONED DEPENDING ON THE OUTCOME OF THE STUDY. ALL MODIFICATIONS SHALL BE REVIEWED AND APPROVED BY THE DPW AND THE FIRE DEPARTMENT.
6. PROPOSED WATER MAIN WILL REMAIN PRIVATE AND A PRIVATE WATER MAIN MAINTENANCE AGREEMENT WITH THE CITY IS REQUIRED.
7. ALL WATER MAIN INSTALLATIONS SHALL BE CLASS 52, CEMENT LINED DUCTILE IRON PIPE.
8. ALL WATER MAIN INSTALLATIONS SHALL BE PRESSURE TESTED AND CHLORINATED AFTER CONSTRUCTION PRIOR TO ACTIVATING THE SYSTEM. CONTRACTOR SHALL COORDINATE CHLORINATION AND TESTING WITH THE CITY OF PORTSMOUTH WATER DEPARTMENT.
9. ALL SEWER PIPE SHALL BE PVC SDR 35 UNLESS OTHERWISE STATED.
10. COORDINATE ALL WORK WITHIN PUBLIC RIGHT OF WAYS WITH THE CITY OF PORTSMOUTH.
11. CONTRACTOR SHALL MAINTAIN UTILITY SERVICES TO ABUTTING PROPERTIES THROUGHOUT CONSTRUCTION.
12. CONNECTION TO EXISTING WATER MAIN SHALL BE CONSTRUCTED TO CITY OF PORTSMOUTH STANDARDS.
13. EXISTING UTILITIES TO BE REMOVED SHALL BE CAPPED AT THE MAIN AND MEET THE DEPARTMENT OF PUBLIC WORKS STANDARDS FOR CAPPING OF WATER AND SEWER SERVICES.
14. ALL ELECTRICAL MATERIAL WORKMANSHIP SHALL CONFORM TO THE NATIONAL ELECTRIC CODE, LATEST EDITION, AND ALL APPLICABLE STATE AND LOCAL CODES.
15. THE EXACT LOCATION OF NEW UTILITY SERVICES AND CONNECTIONS SHALL BE COORDINATED WITH THE BUILDING DRAWINGS AND THE APPLICABLE UTILITY COMPANIES.
16. ADJUST ALL MANHOLES, CATCH BASINS, CURB BOXES, ETC. WITHIN LIMITS OF WORK TO FINISH GRADE.
17. ALL UNDERGROUND CONDUITS SHALL HAVE NYLON PULL ROPES TO FACILITATE PULLING CABLES.
18. THE CONTRACTOR SHALL OBTAIN, PAY FOR, AND COMPLY WITH ALL REQUIRED PERMITS, ARRANGE FOR ALL INSPECTIONS, AND SUBMIT COPIES OF ACCEPTANCE CERTIFICATES TO THE OWNER PRIOR TO THE COMPLETION OF THIS PROJECT.
19. THE CONTRACTOR SHALL PROVIDE AND INSTALL ALL MANHOLES, BOXES, FITTINGS, CONNECTORS, COVER PLATES, AND OTHER MISCELLANEOUS ITEMS NOT NECESSARILY DETAILED ON THESE DRAWINGS TO RENDER INSTALLATION OF UTILITIES COMPLETE AND OPERATIONAL.
20. CONTRACTOR SHALL PROVIDE EXCAVATION, BEDDING, BACKFILL AND COMPACTION FOR NATURAL GAS SERVICES.
21. A 10-FOOT MINIMUM EDGE TO EDGE HORIZONTAL SEPARATION SHALL BE PROVIDED BETWEEN ALL WATER AND SANITARY SEWER LINES. AN 18-INCH MINIMUM OUTSIDE TO OUTSIDE VERTICAL SEPARATION SHALL BE PROVIDED AT ALL WATER/SANITARY SEWER CROSSINGS.
22. THE CONTRACTOR SHALL CONTRACT "DIG-SAFE" 72 HOURS PRIOR TO COMMENCING CONSTRUCTION. THE CONTRACTOR SHALL HAVE THE "DIG-SAFE" NUMBER ON SITE AT ALL TIMES.
23. CONTRACTOR TO SUBMIT AS-BUILT PLANS ON REPRODUCIBLE MYLARS AND IN DIGITAL FORMAT (.DWG FILES) TO THE OWNER AND ENGINEER UPON COMPLETION OF THE PROJECT. AS-BUILTS SHALL BE PREPARED AND CERTIFIED BY A NEW HAMPSHIRE LICENSED LAND SURVEYOR OR PROFESSIONAL ENGINEER.
24. SAW CUT AND REMOVE PAVEMENT AND CONSTRUCT PAVEMENT TRENCH PATCH FOR ALL PROPOSED UTILITIES LOCATED IN EXISTING PAVEMENT AREAS TO REMAIN.
25. HYDRANTS, GATE VALVES, FITTINGS, ETC. SHALL MEET THE REQUIREMENTS OF THE CITY OF PORTSMOUTH.
26. COORDINATE TESTING OF SEWER CONSTRUCTION WITH THE CITY OF PORTSMOUTH.
27. ALL SEWER PIPE WITH LESS THAN 6' OF COVER IN PAVED AREAS OR LESS THAN 4' OF COVER IN UNPAVED AREAS SHALL BE INSULATED.
28. CONTRACTOR SHALL COORDINATE ALL ELECTRIC WORK INCLUDING BUT NOT LIMITED TO: CONDUIT CONSTRUCTION, MANHOLE CONSTRUCTION, UTILITY POLE CONSTRUCTION, OVERHEAD WIRE RELOCATION, AND TRANSFORMER CONSTRUCTION WITH POWER COMPANY.
29. CONTRACTOR SHALL PHASE UTILITY CONSTRUCTION, PARTICULARLY WATER MAIN AND GAS MAIN CONSTRUCTION AS TO MAINTAIN CONTINUOUS SERVICE TO ABUTTING PROPERTIES. CONTRACTOR SHALL COORDINATE TEMPORARY SERVICES TO ABUTTERS WITH THE UTILITY COMPANY AND AFFECTED ABUTTER.
30. SITE LIGHTING SPECIFICATIONS, CONDUIT LAYOUT AND CIRCUITRY FOR PROPOSED SITE LIGHTING AND SIGN ILLUMINATION SHALL BE PROVIDED BY THE PROJECT ELECTRICAL ENGINEER.
31. CONTRACTOR SHALL CONSTRUCT ALL UTILITIES AND DRAINS TO WITHIN 10' OF THE FOUNDATION WALLS AND CONNECT THESE TO SERVICE STUBS FROM THE BUILDING.
32. ALL CONDITIONS ON THIS PLAN SHALL REMAIN IN EFFECT IN PERPETUITY PURSUANT TO THE REQUIREMENTS OF THE SITE PLAN REVIEW REGULATIONS.

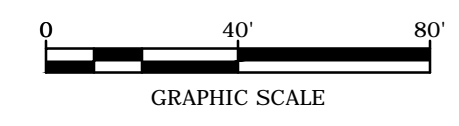
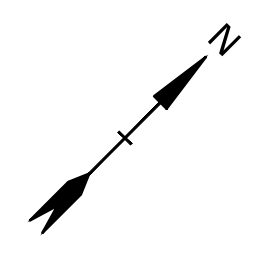

NORTH MILL POND (TIDAL)

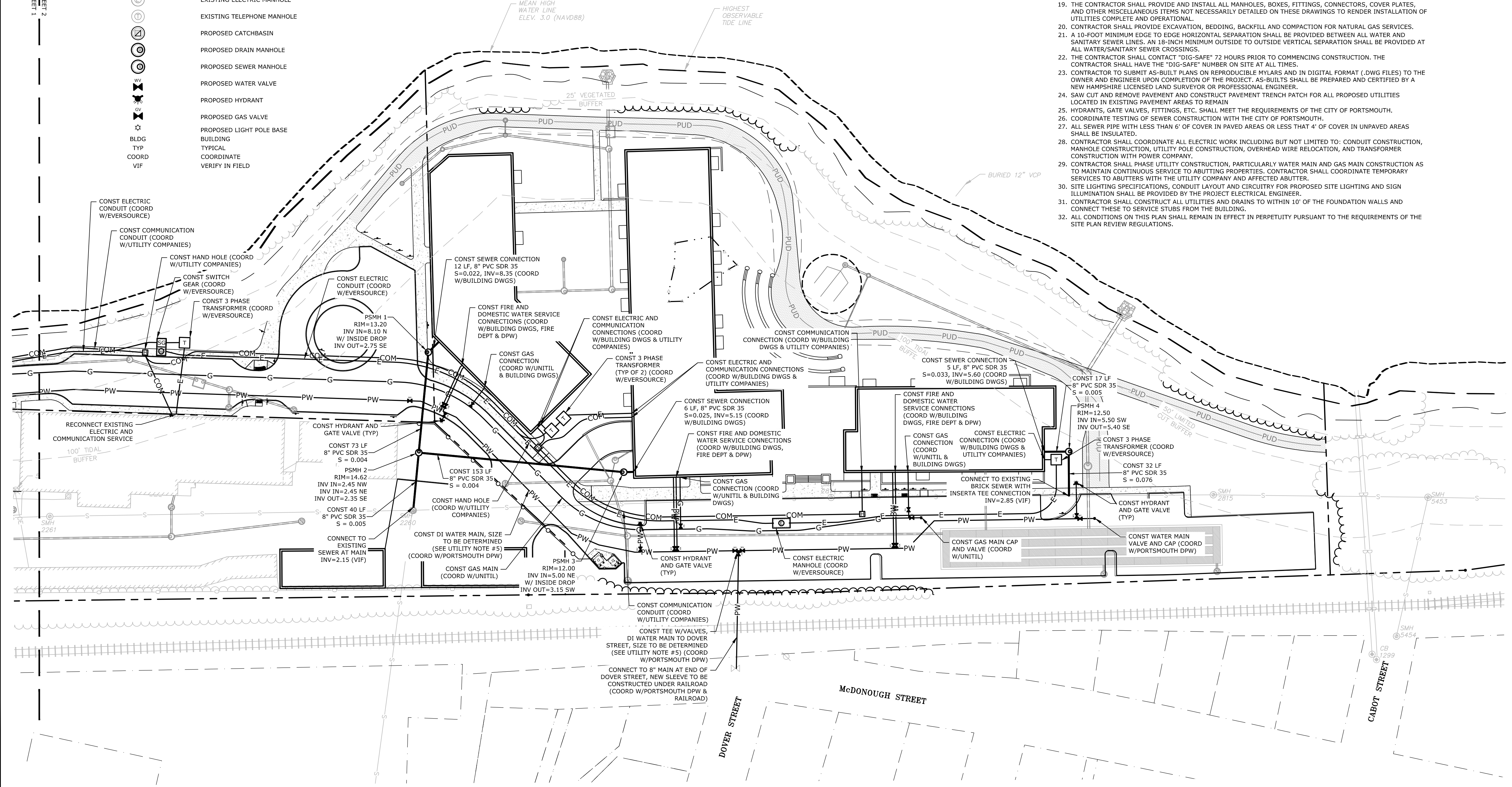

Proposed Multi-Family Development

Iron Horse Properties, LLC

**105 Bartlett Street
Portsmouth,
New Hampshire**

MARK	DATE	DESCRIPTION
I	3/10/2021	PB Submission
H	1/20/2021	TAC Resubmission
G	11/18/2020	TAC Resubmission
F	10/28/2020	Wetland CUP Resubmission
E	5/20/2020	TAC Resubmission
D	4/29/2020	Wetland CUP Submission
C	4/20/2020	TAC Submission
B	2/6/2020	Design Review Submission
A	1/2/2020	ZBA Submission

PROJECT NO:	C-0960-006
DATE:	April 20, 2020
FILE:	C-0960-006_C-SITE.DWG
DRAWN BY:	NAH
CHECKED:	PMC
APPROVED:	BML

UTILITIES PLAN

SCALE: AS SHOWN

C-104.2

Last Saved: 3/10/2021
 Plotted On: Mar 10, 2021 1:58:48pm By: N.Hansman
 Tighe & Bond, F.C. Collins, C. 0960-006 105 Bartlett Street Drawings, Figures AutoCAD Sheet C-0960-006 C-SITE.dwg

StatArea_1
 LARGE, MAIN PARKING LOT AREA ONLY
 Illuminance (Fc)
 Average = 0.73
 Maximum = 3.5
 Minimum = 0.1
 Avg/Min Ratio = 7.30
 Max/Min Ratio = 35.00

Symbol	Qty	Label	Arrangement	Description	CRI	Lum. Lumens	[MANUFAC]
⊙	10	B	SINGLE	CAV414-LT-WA-20W3K-U-5-N-BK	80	1775	Pemco Lighting Products Inc.
●	6	P3	SINGLE	SOUTH-NL-40W3K-U-3-N-BK/ POLE STYLE TBD	85	4126	PEMCO
●	7	P4	SINGLE	SOUTH-NL-40W3K-U-4-N-BK/ POLE STYLE TBD	85	4137	PEMCO
●	2	P5	SINGLE	SOUTH-NL-40W3K-U-5-N-BK/ POLE STYLE TBD	80	4209	PEMCO
⊕	25	W1	SINGLE	CNSRPF600-DR20E0-SXX/ WALLMOUNTED 15' ARGG	70	4538	EMCON - MCGRAW-EDISON (FORMER COOPER LIG

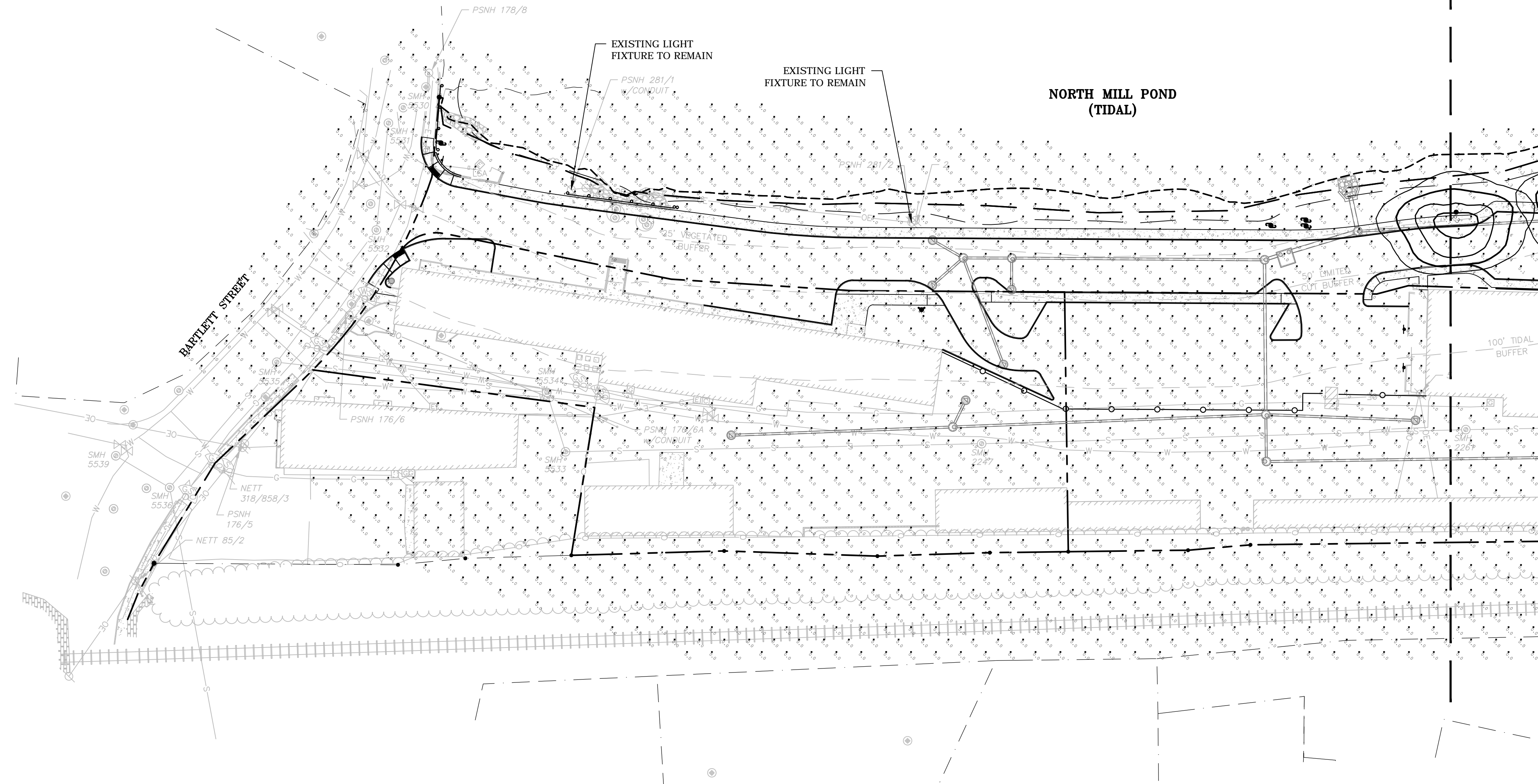
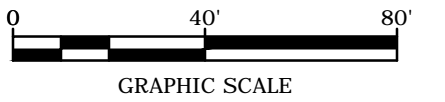
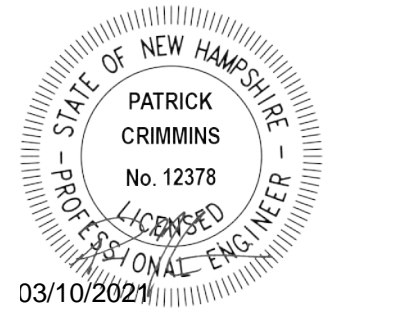
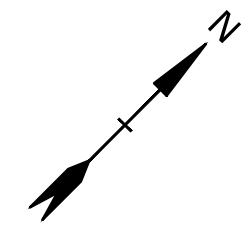

MATCH LINE SHEET 2
MATCH LINE SHEET 1

**Proposed
 Multi-Family
 Development**

**Iron Horse
 Properties, LLC**

**105 Bartlett Street
 Portsmouth,
 New Hampshire**

MARK	DATE	DESCRIPTION
I	3/10/2021	PB Submission
H	1/20/2021	TAC Resubmission
G	11/18/2020	TAC Resubmission
F	10/28/2020	Wetland CUP Resubmission
E	5/20/2020	TAC Resubmission
D	4/29/2020	Wetland CUP Submission
C	4/20/2020	TAC Submission
B	2/6/2020	Design Review Submission
A	1/2/2020	ZBA Submission

PROJECT NO:	C-0960-006
DATE:	April 20, 2020
FILE:	C-0960-006_C-SITE.DWG
DRAWN BY:	NAH
CHECKED:	PMC
APPROVED:	BML

PHOTOMETRIC PLAN

SCALE: AS SHOWN

C-105.1

StatArea 1
 LARGE, MAIN PARKING LOT AREA ONLY
 Illuminance (Fc)
 Average = 0.73
 Maximum = 3.5
 Minimum = 0.1
 Avg/Min Ratio = 7.30
 Max/Min Ratio = 35.00

Symbol	Qty	Label	Arrangement	Description	CRI	Lum. Lumens	[MANUFAC]
○	10	B	SINGLE	CAV414-LT-WA-20W3K-U-5-N-BK	80	1775	Pemco Lighting Products Inc.
●	6	P3	SINGLE	SOUTH-NL-40W3K-U-3-N-BK/ POLE STYLE TBD	85	4126	PEMCO
●	7	P4	SINGLE	SOUTH-NL-40W3K-U-4-N-BK/ POLE STYLE TBD	85	4137	PEMCO
●	2	P5	SINGLE	SOUTH-NL-40W3K-U-5-N-BK/ POLE STYLE TBD	80	4209	PEMCO
○	25	W1	SINGLE	CNSR4FF600-DR20E0-SKK/ WALLMOUNTED 15' ARGG	70	4538	PEMCO - MCGRAW-EDISON (FORMER COOPER LIG

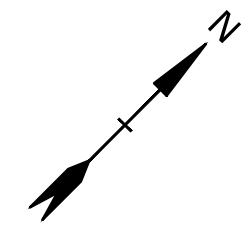

**NORTH MILL POND
(TIDAL)**

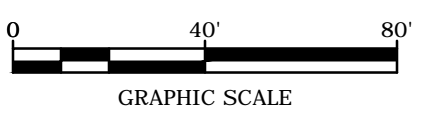
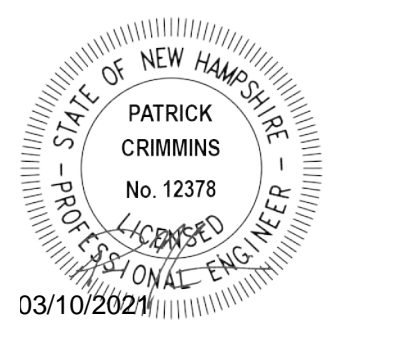
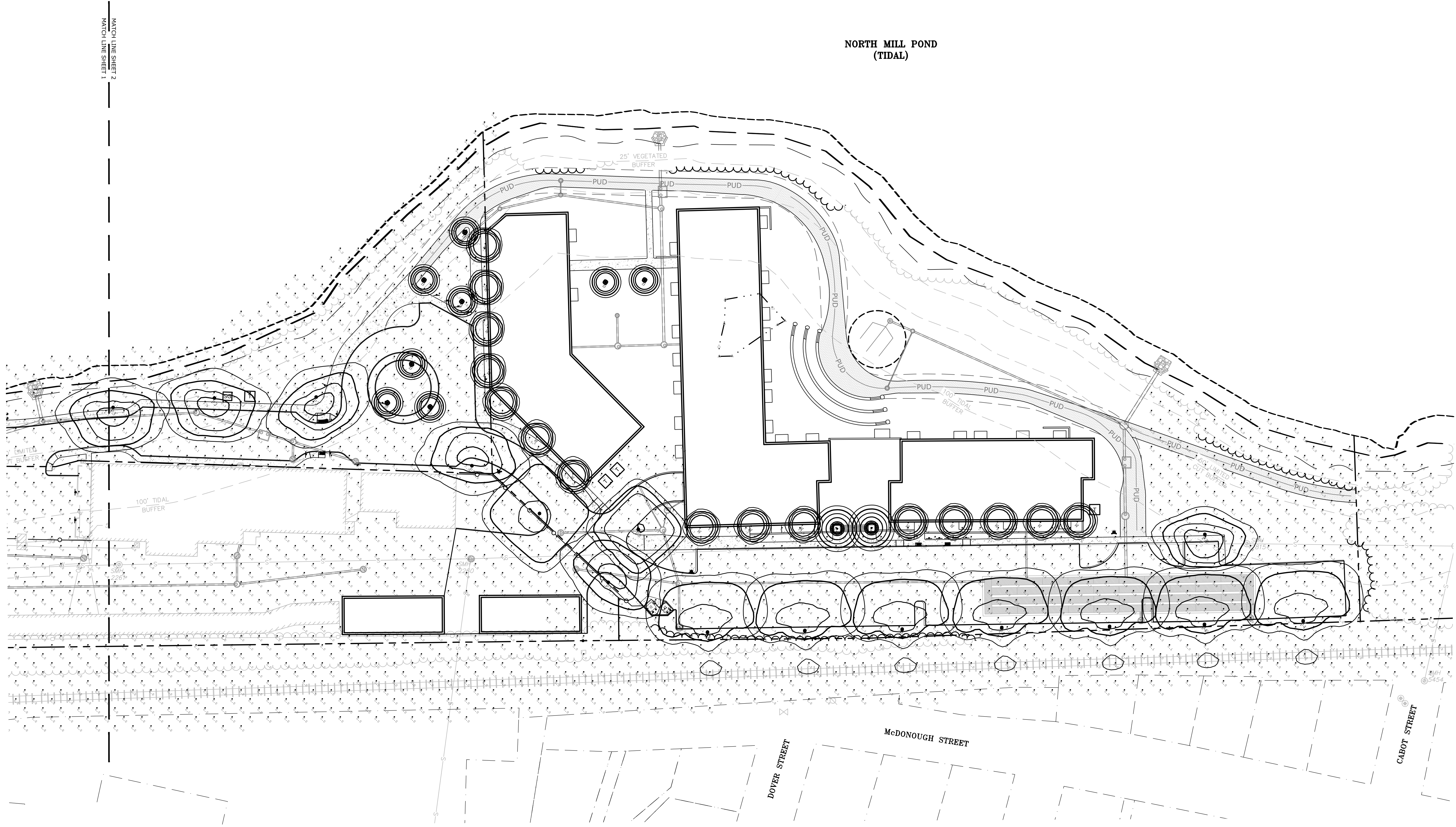

**Proposed
Multi-Family
Development**

**Iron Horse
Properties, LLC**

**105 Bartlett Street
Portsmouth,
New Hampshire**

I	3/10/2021	PB Submission
H	1/20/2021	TAC Resubmission
G	11/18/2020	TAC Resubmission
F	10/28/2020	Wetland CUP Resubmission
E	5/20/2020	TAC Resubmission
D	4/29/2020	Wetland CUP Submission
C	4/20/2020	TAC Submission
B	2/6/2020	Design Review Submission
A	1/2/2020	ZBA Submission

MARK	DATE	DESCRIPTION
PROJECT NO:	C-0960-006	
DATE:	April 20, 2020	
FILE:	C-0960-006_C-SITE.DWG	
DRAWN BY:	NAH	
CHECKED:	PMC	
APPROVED:	BML	

PHOTOMETRIC PLAN

SCALE: AS SHOWN

C-105.2

Last Saved: 3/10/2021
 Plotted On: Mar 10, 2021 1:48:50am By: N.Hansman
 Tighe & Bond, F.C. Collins, C. 0960-006 105 Bartlett Street Drawings, Figures AutoCAD Sheet C-0960-006 C-SITE.dwg

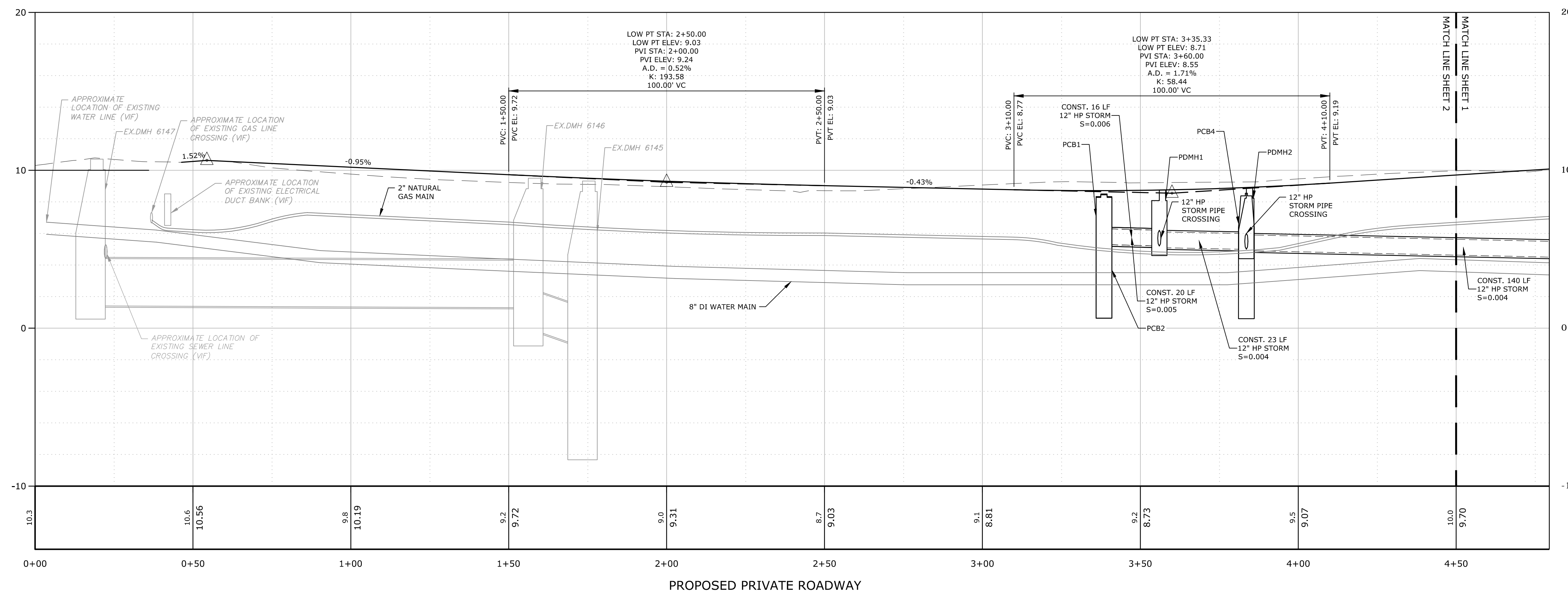
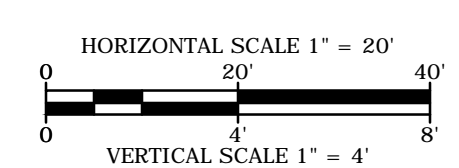
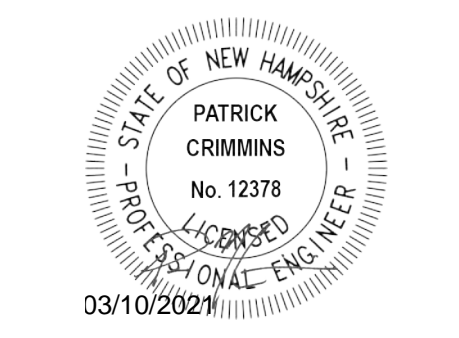
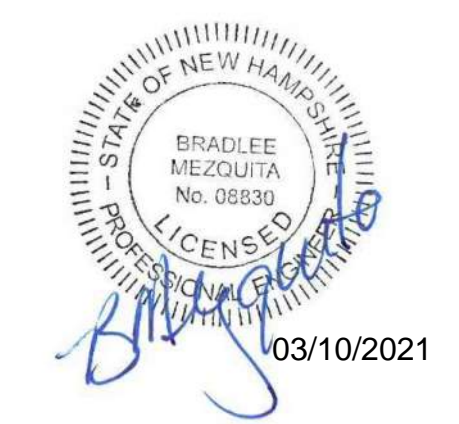
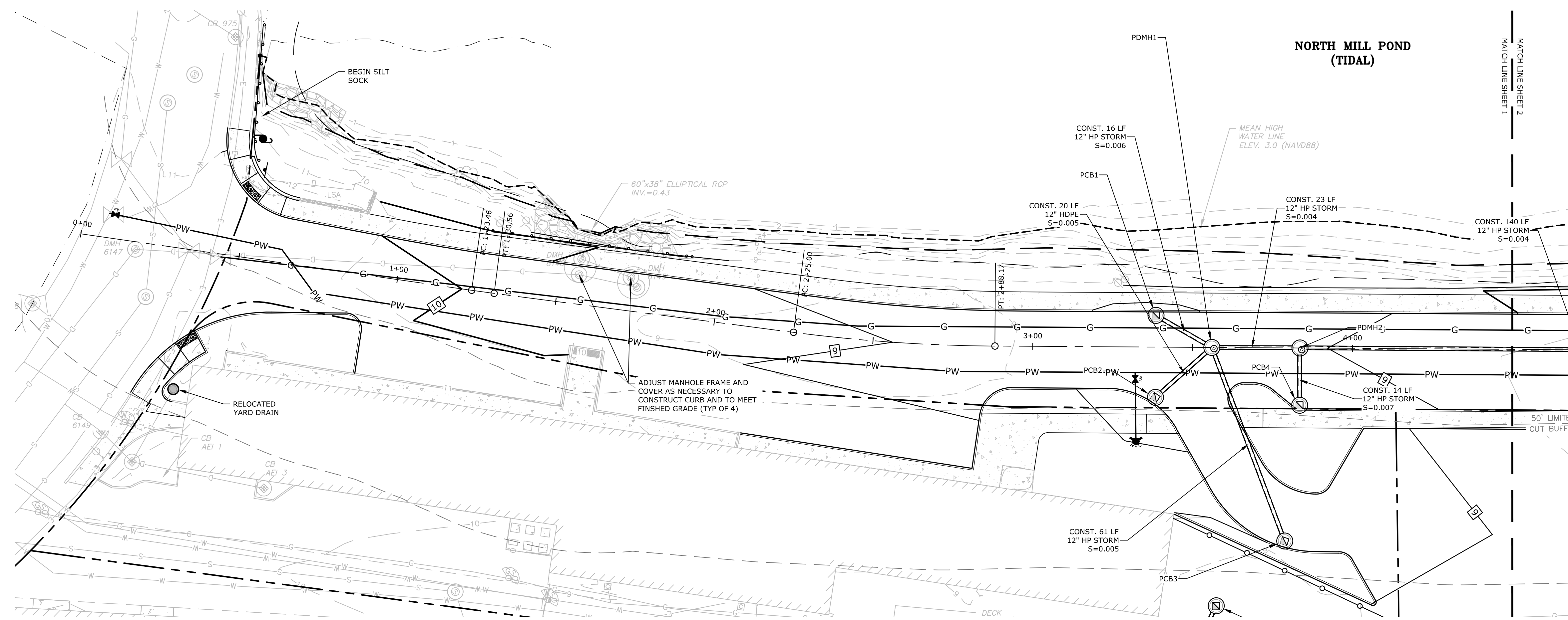
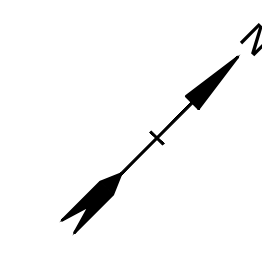

Proposed Multi-Family Development

Iron Horse Properties, LLC

**105 Bartlett Street
Portsmouth,
New Hampshire**

MARK	DATE	DESCRIPTION
I	3/10/2021	PB Submission
H	1/20/2021	TAC Resubmission
G	11/18/2020	TAC Resubmission
F	10/28/2020	Wetland CUP Resubmission
E	5/20/2020	TAC Resubmission
D	4/29/2020	Wetland CUP Submission
C	4/20/2020	TAC Submission
B	2/6/2020	Design Review Submission
A	1/2/2020	ZBA Submission

PROJECT NO:	C-0960-006
DATE:	April 20, 2020
FILE:	C-0960-006_C-SITE.DWG
DRAWN BY:	NAH
CHECKED:	PMC
APPROVED:	BML

ROADWAY PLAN & PROFILE



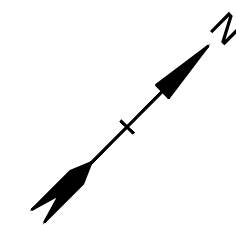

SCALE: AS SHOWN

C-201.1

Last Saved: 3/10/2021
 Plotted On: Mar 10, 2021 1:58:50pm By: NAmanseri
 Tighe & Bond, Inc. C:\p0960-006_105 Bartlett Street Drawings - Figures AutoCAD Sheet C-0960-006_C-SITE.dwg

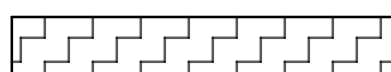

LEGEND

-  PROPOSED SEWER EASEMENT
-  PROPOSED DRAINAGE EASEMENT
-  PROPOSED PARKING EASEMENT
-  PROPOSED WATER EASEMENT
-  PROPOSED COMMUNITY SPACE EASEMENT

EASEMENTS SHOWN HEREIN ARE FOR PERMITTING PURPOSES ONLY. FINAL EASEMENT PLAN SHALL BE PREPARED BY THE PROJECT SURVEYOR AND RECORDED AT THE ROCKINGHAM COUNTY REGISTRY OF DEED PRIOR TO ISSUING BUILDING PERMITS.

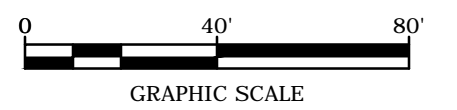
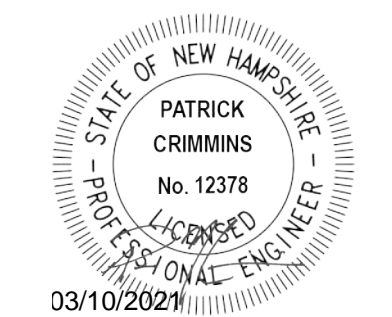

NORTH MILL POND (TIDAL)

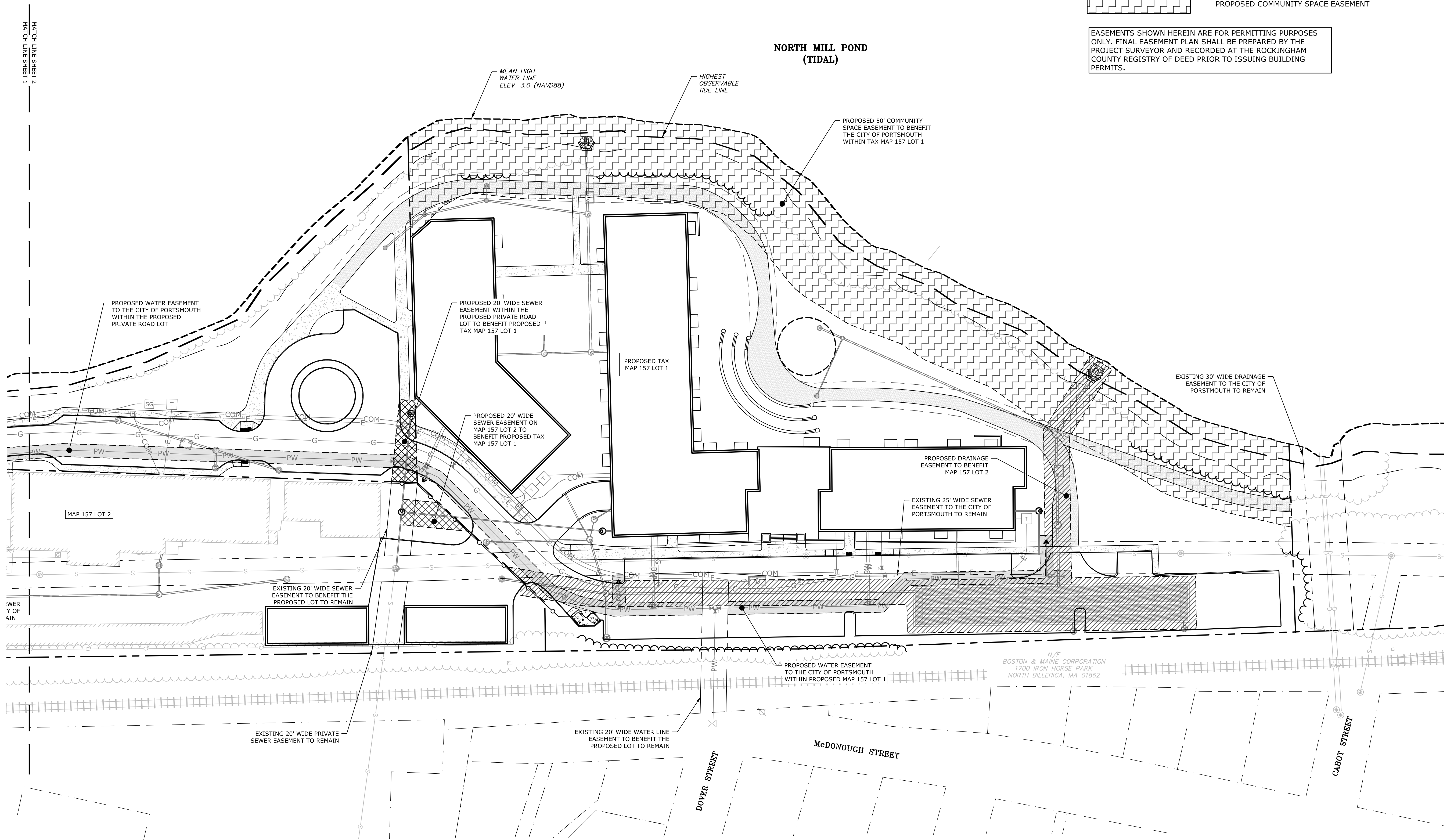

Proposed Multi-Family Development

Iron Horse Properties, LLC

105 Bartlett Street
Portsmouth,
New Hampshire

MARK	DATE	DESCRIPTION
I	3/10/2021	PB Submission
H	1/20/2021	TAC Resubmission
G	11/18/2020	TAC Resubmission
F	10/28/2020	Wetland CUP Resubmission
E	5/20/2020	TAC Resubmission
D	4/29/2020	Wetland CUP Submission
C	4/20/2020	TAC Submission
B	2/6/2020	Design Review Submission
A	1/2/2020	ZBA Submission

PROJECT NO:	C-0960-006
DATE:	April 20, 2020
FILE:	C-0960-006_C-SITE.DWG
DRAWN BY:	NAH
CHECKED:	PMC
APPROVED:	BML

UTILITY EASEMENT PLAN

SCALE: AS SHOWN

C-301.2

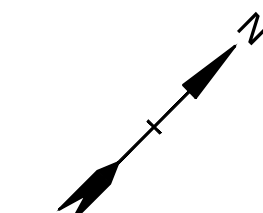

LEGEND

- PROPOSED ACCESS EASEMENT TO BENEFIT MAP 164 LOT 4-2
- PROPOSED ACCESS EASEMENT TO BENEFIT THE CITY OF PORTSMOUTH

EASEMENTS SHOWN HEREIN ARE FOR PERMITTING PURPOSES ONLY. FINAL EASEMENT PLAN SHALL BE PREPARED BY THE PROJECT SURVEYOR AND RECORDED AT THE ROCKINGHAM COUNTY REGISTRY OF DEED PRIOR TO ISSUING BUILDING PERMITS.

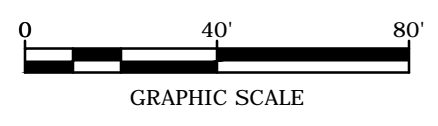
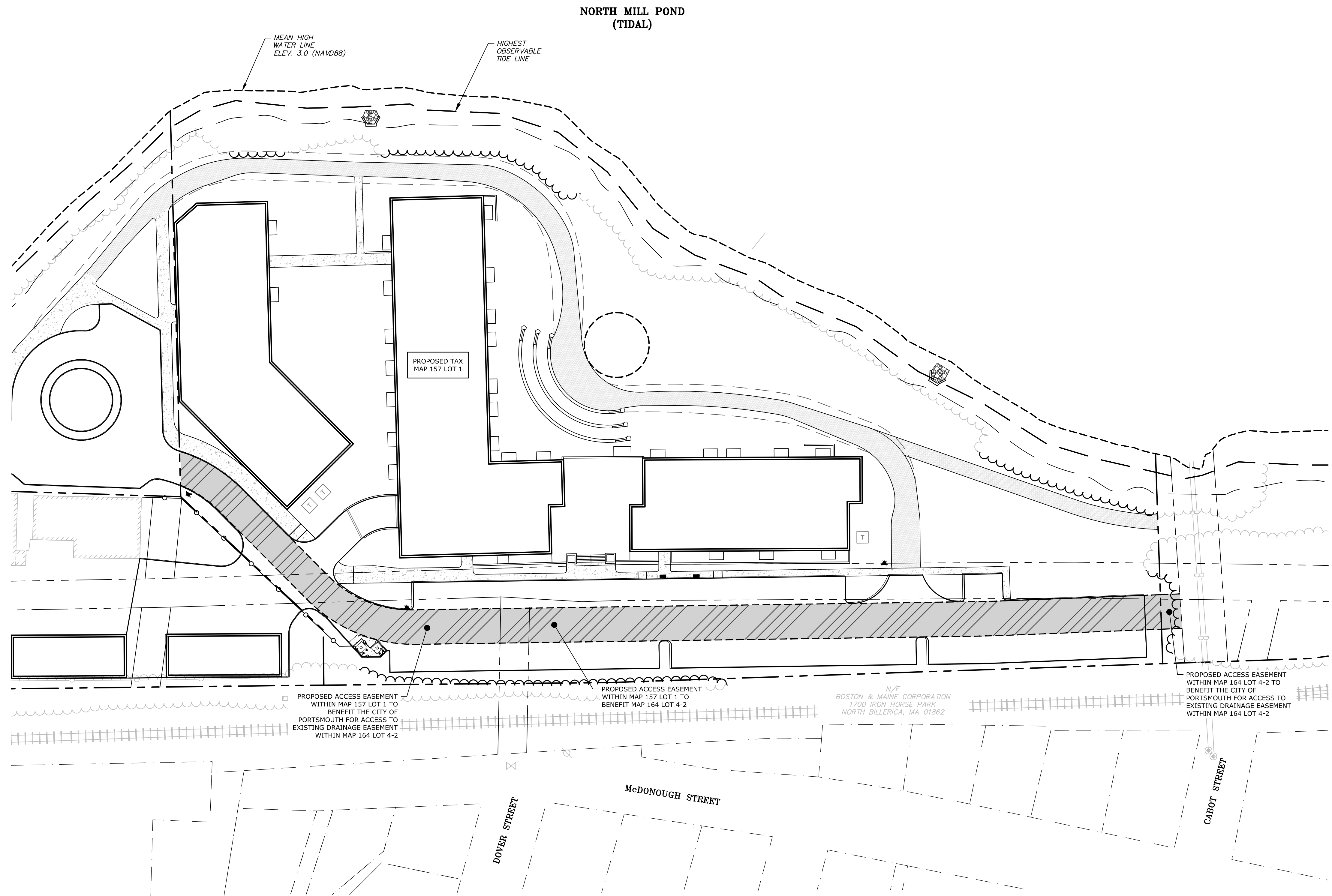

Proposed Multi-Family Development

Iron Horse Properties, LLC

105 Bartlett Street
Portsmouth,
New Hampshire

MARK	DATE	DESCRIPTION
I	3/10/2021	PB Submission
H	1/20/2021	TAC Resubmission
G	11/18/2020	TAC Resubmission
F	10/28/2020	Wetland CUP Resubmission
E	5/20/2020	TAC Resubmission
D	4/29/2020	Wetland CUP Submission
C	4/20/2020	TAC Submission
B	2/6/2020	Design Review Submission
A	1/2/2020	ZBA Submission

PROJECT NO:	C-0960-006
DATE:	April 20, 2020
FILE:	C-0960-006_C-SITE.DWG
DRAWN BY:	NAH
CHECKED:	PMC
APPROVED:	BML

ACCESS EASEMENT PLAN

SCALE: AS SHOWN

Last Saved: 3/10/2021 1:48:52pm By: N.Hansman
 Plotted On: Mar 10, 2021 1:48:52pm By: N.Hansman
 Tighe & Bond, P.C. 03041-006 105 Bartlett Street Drawings Figures AutoCAD Sheet C-0960-006 C-SITE.dwg

GENERAL PROJECT INFORMATION

PROJECT APPLICANT: IRON HORSE PROPERTIES, LLC
PROJECT MAP/LOT: MAP 157 / LOT 1
PROJECT NAME: PROPOSED MULTI-FAMILY DEVELOPMENT
PROJECT ADDRESS: 105 BARTLETT STREET
PROJECT LATITUDE/LONGITUDE: 43°-04'-20" N / 70°-46'-15" W

PROJECT DESCRIPTION

THE PROJECT CONSISTS OF CONSTRUCTING THREE (3) MULTI-FAMILY APARTMENT BUILDINGS WITH TWO (2) OF THE BUILDINGS CONTAINING BASEMENT LEVEL PARKING.

DISTURBED AREA

THE TOTAL AREA TO BE DISTURBED IS APPROXIMATELY 6.5 ACRES.

SOIL CHARACTERISTICS

BASED ON THE SITE SPECIFIC SOIL SURVEY CONDUCTED BY LEONARD LORD, PHD, CSS, CSW ON OCTOBER 29 AND DECEMBER 2, 2019, THE SOILS ON SITE CONSIST OF URBAN FILLS WITH A HYDROLOGIC SOIL GROUP RATING OF A TO D.

NAME OF RECEIVING WATERS

THE STORMWATER RUNOFF FROM THE SITE WILL BE DISCHARGED VIA SUBSURFACE DRAINAGE WHICH ULTIMATELY FLOWS TO NORTH MILL POND.

CONSTRUCTION SEQUENCE OF MAJOR ACTIVITIES:

- 1. CUT AND CLEAR TREES.
2. CONSTRUCT TEMPORARY AND PERMANENT SEDIMENT, EROSION AND DETENTION CONTROL FACILITIES.
3. ALL PERMANENT DITCHES, SWALES, DETENTION, RETENTION AND SEDIMENTATION BASINS TO BE STABILIZED USING THE VEGETATIVE AND NON-STRUCTURAL BMPs PRIOR TO DIRECTING RUNOFF TO THEM.
4. CLEAR AND DISPOSE OF DEBRIS.
5. CONSTRUCT TEMPORARY CULVERTS AND DIVERSION CHANNELS AS REQUIRED.
6. GRADE AND GRAVEL ROADWAYS AND PARKING AREAS - ALL ROADS AND PARKING AREA SHALL BE STABILIZED WITHIN 72 HOURS OF ACHIEVING FINISHED GRADE.
7. BEGIN PERMANENT AND TEMPORARY SEEDING AND MULCHING.
8. DAILY, OR AS REQUIRED, CONSTRUCT TEMPORARY BERMS, DRAINS, DITCHES, PERIMETER EROSION CONTROL MEASURES, SEDIMENT TRAPS, ETC., MULCH AND SEED AS REQUIRED.
9. SEDIMENT TRAPS AND/OR BASINS SHALL BE USED AS NECESSARY TO CONTAIN RUNOFF UNTIL SOILS ARE STABILIZED.
10. FINISH PAVING ALL ROADWAYS AND PARKING LOTS.
11. INSPECT AND MAINTAIN ALL EROSION AND SEDIMENT CONTROL MEASURES.
12. COMPLETE PERMANENT SEEDING AND LANDSCAPING.
13. REMOVE TRAPPED SEDIMENTS FROM COLLECTOR DEVICES AS APPROPRIATE AND THEN REMOVE TEMPORARY EROSION CONTROL MEASURES.

SPECIAL CONSTRUCTION NOTES:

- 1. THE CONSTRUCTION SEQUENCE MUST LIMIT THE DURATION AND AREA OF DISTURBANCE.
2. THE PROJECT IS TO BE MANAGED IN A MANNER THAT MEETS THE REQUIREMENTS AND INTENT OF RSA 430:53 AND CHAPTER AGR 3800 RELATIVE TO INVASIVE SPECIES.

EROSION CONTROL NOTES:

- 1. ALL EROSION CONTROL MEASURES AND PRACTICES SHALL CONFORM TO THE "NEW HAMPSHIRE STORMWATER MANUAL VOLUME 3: EROSION AND SEDIMENT CONTROLS DURING CONSTRUCTION" PREPARED BY THE NHDES.
2. PRIOR TO ANY WORK OR SOIL DISTURBANCE, CONTRACTOR SHALL SUBMIT SHOP DRAWINGS FOR EROSION CONTROL MEASURES AS REQUIRED IN THE PROJECT MANUAL.
3. CONTRACTOR SHALL INSTALL TEMPORARY EROSION CONTROL BARRIERS, INCLUDING HAY BALES, SILT FENCES, MULCH BERMS, SILT SACKS AND SILT SOCKS AS SHOWN IN THESE DRAWINGS AS THE FIRST ORDER OF WORK.
4. SILT SACK INLET PROTECTION SHALL BE INSTALLED IN ALL EXISTING AND PROPOSED CATCH BASIN INLETS WITHIN THE WORK LIMITS AND BE MAINTAINED FOR THE DURATION OF THE PROJECT.
5. PERIMETER CONTROLS INCLUDING SILT FENCES, MULCH BERM, SILT SOCK, AND/OR HAY BALE BARRIERS SHALL BE MAINTAINED FOR THE DURATION OF THE PROJECT UNTIL NON-PAVED AREAS HAVE BEEN STABILIZED.
6. THE CONTRACTOR SHALL REMOVE AND PROPERLY DISPOSE OF ALL TEMPORARY EROSION CONTROL DEVICES UPON COMPLETION OF CONSTRUCTION.
7. ALL DISTURBED AREAS NOT OTHERWISE BEING TREATED SHALL RECEIVE 6" LOAM, SEED AND FERTILIZER.
8. INSPECT ALL INLET PROTECTION AND PERIMETER CONTROLS WEEKLY AND AFTER EACH RAIN STORM OF 0.25 INCH OR GREATER.
9. CONSTRUCT EROSION CONTROL BLANKETS ON ALL SLOPES STEEPER THAN 3:1.

STABILIZATION:

- 1. AN AREA SHALL BE CONSIDERED STABLE WHEN ONE OF THE FOLLOWING HAS OCCURRED:
A. BASE COURSE GRAVELS HAVE BEEN INSTALLED IN AREAS TO BE PAVED;
B. A MINIMUM OF 85% VEGETATED GROWTH HAS BEEN ESTABLISHED;
C. A MINIMUM OF 3" OF NON-EROSIVE MATERIAL SUCH AS STONE OR RIPRAP HAS BEEN INSTALLED;
D. EROSION CONTROL BLANKETS HAVE BEEN PROPERLY INSTALLED.;
E. IN AREAS TO BE PAVED, "STABLE" MEANS THAT BASE COURSE GRAVELS MEETING THE REQUIREMENTS OF NHDOT STANDARD FOR ROAD AND BRIDGE CONSTRUCTION, 2016, ITEM 304.2 HAVE BEEN INSTALLED.
2. WINTER STABILIZATION PRACTICES:
A. ALL PROPOSED VEGETATED AREAS THAT DO NOT EXHIBIT A MINIMUM OF 85 PERCENT VEGETATIVE GROWTH BY OCTOBER 15, OR WHICH ARE DISTURBED AFTER OCTOBER 15, SHALL BE STABILIZED BY SEEDING AND INSTALLING EROSION CONTROL BLANKETS ON SLOPES GREATER THAN 3:1, AND SEEDING AND PLACING 3 TO 4 TONS OF MULCH PER ACRE, SECURED WITH ANCHORED NETTING, ELSEWHERE, THE INSTALLATION OF EROSION CONTROL BLANKETS OR MULCH AND NETTING SHALL NOT OCCUR OVER ACCUMULATED SNOW OR ON FROZEN GROUND AND SHALL BE COMPLETED IN ADVANCE OF THAW OR SPRING MELT EVENTS;
B. ALL DITCHES OR SWALES WHICH DO NOT EXHIBIT A MINIMUM OF 85 PERCENT VEGETATIVE GROWTH BY OCTOBER 15, OR WHICH ARE DISTURBED AFTER OCTOBER 15, SHALL BE STABILIZED TEMPORARILY WITH STONE OR EROSION CONTROL BLANKETS APPROPRIATE FOR THE DESIGN FLOW CONDITIONS;
C. AFTER OCTOBER 15, INCOMPLETE ROAD OR PARKING SURFACES, WHERE WORK HAS STOPPED FOR THE WINTER SEASON, SHALL BE PROTECTED WITH A MINIMUM OF 3 INCHES OF CRUSHED GRAVEL PER NHDOT ITEM 304.3, OR IF CONSTRUCTION IS TO CONTINUE THROUGH THE WINTER SEASON BE CLEARED OF ANY ACCUMULATED SNOW AFTER EACH STORM EVENT;
3. STABILIZATION SHALL BE INITIATED ON ALL LOAM STOCKPILES, AND DISTURBED AREAS, WHERE CONSTRUCTION ACTIVITY SHALL NOT OCCUR FOR MORE THAN TWENTY-ONE (21) CALENDAR DAYS BY THE FOURTEENTH (14TH) DAY AFTER CONSTRUCTION ACTIVITY HAS PERMANENTLY OR TEMPORARILY CEASED IN THAT AREA. STABILIZATION MEASURES TO BE USED INCLUDE:
A. TEMPORARY SEEDING;
B. MULCHING.
4. ALL AREAS SHALL BE STABILIZED WITHIN 45 DAYS OF INITIAL DISTURBANCE.
5. WHEN CONSTRUCTION ACTIVITY PERMANENTLY OR TEMPORARILY CEASES WITHIN 100 FEET OF NEARBY SURFACE WATERS OR DELINEATED WETLANDS, THE AREA SHALL BE STABILIZED WITHIN SEVEN (7) DAYS OR PRIOR TO A RAIN EVENT. ONCE CONSTRUCTION ACTIVITY CEASES PERMANENTLY IN AN THESE AREAS, SILT FENCES, MULCH BERMS, HAY BALE BARRIERS AND ANY EARTH/DIKES SHALL BE REMOVED ONCE PERMANENT MEASURES ARE ESTABLISHED.
6. DURING CONSTRUCTION, RUNOFF WILL BE DIVERTED AROUND THE SITE WITH EARTH DIKES, PIPING OR STABILIZED CHANNELS WHERE POSSIBLE. SHEET RUNOFF FROM THE SITE WILL BE FILTERED THROUGH SILT FENCES, MULCH BERMS, HAY BALE BARRIERS, OR SILT SOCKS. ALL STORM DRAIN BASIN INLETS SHALL BE PROVIDED WITH FLARED END SECTIONS AND TRASH

RACKS. THE SITE SHALL BE STABILIZED FOR THE WINTER BY OCTOBER 15.

DUST CONTROL:

- 1. THE CONTRACTOR SHALL BE RESPONSIBLE TO CONTROL DUST THROUGHOUT THE CONSTRUCTION PERIOD.
2. DUST CONTROL METHODS SHALL INCLUDE, BUT BE NOT LIMITED TO SPRINKLING WATER ON EXPOSED AREAS, COVERING LOADED DUMP TRUCKS LEAVING THE SITE, AND TEMPORARY MULCHING.
3. DUST CONTROL MEASURES SHALL BE UTILIZED SO AS TO PREVENT THE MIGRATION OF DUST FROM THE SITE TO ABUTTING AREAS.

STOCKPILES:

- 1. LOCATE STOCKPILES A MINIMUM OF 50 FEET AWAY FROM CATCH BASINS, SWALES, AND CULVERTS.
2. ALL STOCKPILES SHOULD BE SURROUNDED WITH TEMPORARY EROSION CONTROL MEASURES PRIOR TO THE ONSET OF PRECIPITATION.
3. PERIMETER BARRIERS SHOULD BE MAINTAINED AT ALL TIMES, AND ADJUSTED AS NEEDED TO ACCOMMODATE THE DELIVERY AND REMOVAL OF MATERIALS FROM THE STOCKPILE.
4. PROTECT ALL STOCKPILES FROM STORMWATER RUN-OFF USING TEMPORARY EROSION CONTROL MEASURES SUCH AS BERMS, SILT SOCK, OR OTHER APPROVED PRACTICE TO PREVENT MIGRATION OF MATERIAL BEYOND THE IMMEDIATE CONFINES OF THE STOCKPILES.

OFF SITE VEHICLE TRACKING:

- 1. THE CONTRACTOR SHALL CONSTRUCT STABILIZED CONSTRUCTION ENTRANCE(S) PRIOR TO ANY EXCAVATION ACTIVITIES.

VEGETATION:

- 1. TEMPORARY GRASS COVER:
A. SEEDBED PREPARATION:
a. SEE LANDSCAPE PLAN FOR SEEDBED PREPARATION REQUIREMENTS;
B. SEEDING:
a. SEE LANDSCAPE PLAN FOR SEEDING REQUIREMENTS;
C. MAINTENANCE:
a. TEMPORARY SEEDING SHALL BE PERIODICALLY INSPECTED.
2. VEGETATIVE PRACTICE:
A. SEE LANDSCAPE PLAN FOR PERMANENT MEASURES AND PLANTINGS:
a. THE CONTRACTOR SHALL PROTECT AND MAINTAIN THE SEEDED AREAS UNTIL ACCEPTED;
b. IN NO CASE SHALL THE WEED CONTENT EXCEED ONE (1) PERCENT BY WEIGHT.
3. DORMANT SEEDING (SEPTEMBER 15 TO FIRST SNOWFALL):
A. FOLLOW PERMANENT MEASURES REQUIREMENTS.
B. APPLY SEED MIXTURE AT TWICE THE INDICATED RATE.
C. APPLY MULCH AS INDICATED FOR PERMANENT MEASURES.

CONCRETE WASHOUT AREA:

- 1. THE FOLLOWING ARE THE ONLY NON-STORMWATER DISCHARGES ALLOWED. ALL OTHER NON-STORMWATER DISCHARGES ARE PROHIBITED ON SITE:
A. THE CONCRETE DELIVERY TRUCKS SHALL, WHENEVER POSSIBLE, USE WASHOUT FACILITIES AT THEIR OWN PLANT OR DISPATCH FACILITY;
B. IF IT IS NECESSARY, SITE CONTRACTOR SHALL DESIGNATE SPECIFIC WASHOUT AREAS AND DESIGN FACILITIES TO HANDLE ANTICIPATED WASHOUT WATER;
C. CONTRACTOR SHALL LOCATE WASHOUT AREAS AT LEAST 150 FEET AWAY FROM STORM DRAINS, SWALES AND SURFACE WATERS OR DELINEATED WETLANDS;
D. INSPECT WASHOUT FACILITIES DAILY TO DETECT LEAKS OR TEARS AND TO IDENTIFY WHEN MATERIALS NEED TO BE REMOVED.

ALLOWABLE NON-STORMWATER DISCHARGES:

- 1. FIRE-FIGHTING ACTIVITIES;
2. FIRE HYDRANT FLUSHING;
3. WATERS USED TO WASH VEHICLES WHERE DETERGENTS ARE NOT USED;
4. WATER USED TO CONTROL DUST;
5. POTABLE WATER INCLUDING UNCONTAMINATED WATER LINE FLUSHING;
6. ROUTINE EXTERNAL BUILDING WASH DOWN WHERE DETERGENTS ARE NOT USED;
7. PAVEMENT WASH WATERS WHERE DETERGENTS ARE NOT USED;
8. UNCONTAMINATED AIR CONDITIONING/COMPRESSOR CONDENSATION;
9. UNCONTAMINATED GROUND WATER OR SPRING WATER;
10. FOUNDATION OR FOOTING DRAINS WHICH ARE UNCONTAMINATED;
11. UNCONTAMINATED EXCAVATION DEWATERING;
12. LANDSCAPE IRRIGATION.

WASTE DISPOSAL:

- 1. WASTE MATERIAL:
A. ALL WASTE MATERIALS SHALL BE COLLECTED AND STORED IN SECURELY LIDDED RECEPTACLES.
B. NO CONSTRUCTION WASTE MATERIALS SHALL BE BURIED ON SITE;
C. ALL PERSONNEL SHALL BE INSTRUCTED REGARDING THE CORRECT PROCEDURE FOR WASTE DISPOSAL BY THE SUPERINTENDENT.
2. HAZARDOUS WASTE:
A. ALL HAZARDOUS WASTE MATERIALS SHALL BE DISPOSED OF IN THE MANNER SPECIFIED BY LOCAL OR STATE REGULATION OR BY THE MANUFACTURER;
B. SITE PERSONNEL SHALL BE INSTRUCTED IN THESE PRACTICES BY THE SUPERINTENDENT.
3. SANITARY WASTE:
A. ALL SANITARY WASTE SHALL BE COLLECTED FROM THE PORTABLE UNITS A MINIMUM OF ONCE PER WEEK BY A LICENSED SANITARY WASTE MANAGEMENT CONTRACTOR.

SPILL PREVENTION:

- 1. CONTRACTOR SHALL BE FAMILIAR WITH SPILL PREVENTION MEASURES REQUIRED BY LOCAL, STATE AND FEDERAL AGENCIES.
2. THE FOLLOWING ARE THE MATERIAL MANAGEMENT PRACTICES THAT SHALL BE USED TO REDUCE THE RISK OF SPILLS OR OTHER ACCIDENTAL EXPOSURE OF MATERIALS AND SUBSTANCES DURING CONSTRUCTION TO STORMWATER RUNOFF:
A. GOOD HOUSEKEEPING - THE FOLLOWING GOOD HOUSEKEEPING PRACTICE SHALL BE FOLLOWED ON SITE DURING CONSTRUCTION:
a. ONLY SUFFICIENT AMOUNTS OF PRODUCTS TO DO THE JOB SHALL BE STORED ON SITE;
b. ALL REGULATED MATERIALS STORED ON SITE SHALL BE STORED IN A NEAT, ORDERLY MANNER IN THEIR PROPER (ORIGINAL IF POSSIBLE) CONTAINERS AND, IF POSSIBLE, UNDER A ROOF OR OTHER ENCLOSURE, ON AN IMPERVIOUS SURFACE;
c. MANUFACTURER'S RECOMMENDATIONS FOR PROPER USE AND DISPOSAL SHALL BE FOLLOWED;
d. THE SITE SUPERINTENDENT SHALL INSPECT DAILY TO ENSURE PROPER USE AND DISPOSAL OF MATERIALS;
e. SUBSTANCES SHALL NOT BE MIXED WITH ONE ANOTHER UNLESS RECOMMENDED BY THE MANUFACTURER;
f. WHENEVER POSSIBLE ALL OF A PRODUCT SHALL BE USED UP BEFORE DISPOSING OF THE CONTAINER.
g. THE TRAINING OF ON-SITE EMPLOYEES AND THE ON-SITE POSTING OF RELEASE RESPONSE INFORMATION DESCRIBING WHAT TO DO IN THE EVENT OF A SPILL OF REGULATED SUBSTANCES.
B. HAZARDOUS PRODUCTS - THE FOLLOWING PRACTICES SHALL BE USED TO REDUCE THE RISKS ASSOCIATED WITH HAZARDOUS MATERIALS:
a. PRODUCTS SHALL BE KEPT IN THEIR ORIGINAL CONTAINERS UNLESS THEY ARE NOT RESEALABLE;
b. ORIGINAL LABELS AND MATERIAL SAFETY DATA SHALL BE RETAINED FOR IMPORTANT PRODUCT INFORMATION;
c. SURPLUS PRODUCT THAT MUST BE DISPOSED OF SHALL BE DISCARDED ACCORDING TO THE MANUFACTURER'S RECOMMENDED METHODS OF DISPOSAL.
C. PRODUCT SPECIFIC PRACTICES - THE FOLLOWING PRODUCT SPECIFIC PRACTICES SHALL BE FOLLOWED ON SITE:
a. PETROLEUM PRODUCTS:
i. ALL ON SITE VEHICLES SHALL BE MONITORED FOR LEAKS AND RECEIVE REGULAR

- ii. PREVENTIVE MAINTENANCE TO REDUCE LEAKAGE;
PETROLEUM PRODUCTS SHALL BE STORED IN TIGHTLY SEALED CONTAINERS WHICH ARE CLEARLY LABELED. ANY ASPHALT BASED SUBSTANCES USED ON SITE SHALL BE APPLIED ACCORDING TO THE MANUFACTURER'S RECOMMENDATIONS.
iii. SECURE FUEL STORAGE AREAS AGAINST UNAUTHORIZED ENTRY;
iv. INSPECT FUEL STORAGE AREAS WEEKLY;
v. WHEREVER POSSIBLE, KEEP REGULATED CONTAINERS THAT ARE STORED OUTSIDE MORE THAN 50 FEET FROM SURFACE WATER AND STORM DRAINS, 75 FEET FROM PRIVATE WELLS, AND 400 FEET FROM PUBLIC WELLS;
vi. COVER REGULATED CONTAINERS IN OUTSIDE STORAGE AREAS;
vii. SECONDARY CONTAINMENT IS REQUIRED FOR CONTAINERS CONTAINING REGULATED SUBSTANCES STORED OUTSIDE, EXCEPT FOR ON PREMISE USE HEATING FUEL TANKS, OR ABOVEGROUND OR UNDERGROUND STORAGE TANKS OTHERWISE REGULATED.
viii. THE FUEL HANDLING REQUIREMENTS SHALL INCLUDE:
(1) EXCEPT WHEN IN USE, KEEP CONTAINERS CONTAINING REGULATED SUBSTANCES CLOSED AND SEALED;
(2) PLACE DRIP PANS UNDER SPIGOTS, VALVES, AND PUMPS;
(3) HAVE SPILL CONTROL AND CONTAINMENT EQUIPMENT READILY AVAILABLE IN ALL WORK AREAS;
(4) USE FUNNELS AND DRIP PANS WHEN TRANSFERRING REGULATED SUBSTANCES;
(5) PERFORM TRANSFERS OF REGULATED SUBSTANCES OVER AN IMPERVIOUS SURFACE.

- ix. FUELING AND MAINTENANCE OF EXCAVATION, EARTHMOVING AND OTHER CONSTRUCTION RELATED EQUIPMENT SHALL COMPLY WITH THE REGULATIONS OF THE NEW HAMPSHIRE DEPARTMENT OF ENVIRONMENTAL SERVICES THESE REQUIREMENTS ARE SUMMARIZED IN WD-DWGB-22-6 BEST MANAGEMENT PRACTICES FOR FUELING AND MAINTENANCE OF EXCAVATION AND EARTHMOVING EQUIPMENT, OR ITS SUCCESSOR DOCUMENT.
https://www.des.nh.gov/organization/commissioner/PIR/FACTSHEETS/DWGB/DOCUMENTS/DWGB-22-6.PDF
b. FERTILIZERS:
i. FERTILIZERS USED SHALL BE APPLIED ONLY IN THE MINIMUM AMOUNTS DIRECTED BY THE SPECIFICATIONS;
ii. ONCE APPLIED FERTILIZER SHALL BE WORKED INTO THE SOIL TO LIMIT EXPOSURE TO STORMWATER;
iii. STORAGE SHALL BE IN A COVERED SHED OR ENCLOSED TRAILERS. THE CONTENTS OF ANY PARTIALLY USED BAGS OF FERTILIZER SHALL BE TRANSFERRED TO A SEALABLE PLASTIC BIN TO AVOID SPILLS.
c. PAINTS:
i. ALL CONTAINERS SHALL BE TIGHTLY SEALED AND STORED WHEN NOT REQUIRED FOR USE;
ii. EXCESS PAINT SHALL NOT BE DISCHARGED TO THE STORM SEWER SYSTEM;
iii. EXCESS PAINT SHALL BE DISPOSED OF PROPERLY ACCORDING TO MANUFACTURER'S INSTRUCTIONS OR STATE AND LOCAL REGULATIONS.
D. SPILL CONTROL PRACTICES - IN ADDITION TO GOOD HOUSEKEEPING AND MATERIAL MANAGEMENT PRACTICES DISCUSSED IN THE PREVIOUS SECTION, THE FOLLOWING PRACTICES SHALL BE FOLLOWED FOR SPILL PREVENTION AND CLEANUP:
a. MANUFACTURER'S RECOMMENDED METHODS FOR SPILL CLEANUP SHALL BE CLEARLY POSTED AND SITE PERSONNEL SHALL BE MADE AWARE OF THE PROCEDURES AND THE LOCATION OF THE INFORMATION AND CLEANUP SUPPLIES;
b. MATERIALS AND EQUIPMENT NECESSARY FOR SPILL CLEANUP SHALL BE KEPT IN THE MATERIAL STORAGE AREA ON SITE. EQUIPMENT AND MATERIALS SHALL INCLUDE BUT NOT BE LIMITED TO BROOMS, DUSTPANS, MOPS, RAGS, GLOVES, GOGGLES, KITTY LITTER, SAND, SAWDUST AND PLASTIC OR METAL TRASH CONTAINERS SPECIFICALLY FOR THIS PURPOSE;
c. ALL SPILLS SHALL BE CLEANED UP IMMEDIATELY AFTER DISCOVERY;
d. THE SPILL AREA SHALL BE KEPT WELL VENTILATED AND PERSONNEL SHALL WEAR APPROPRIATE PROTECTIVE CLOTHING TO PREVENT INJURY FROM CONTACT WITH A HAZARDOUS SUBSTANCE;
e. SPILLS OF TOXIC OR HAZARDOUS MATERIAL SHALL BE REPORTED TO THE APPROPRIATE LOCAL, STATE OR FEDERAL AGENCIES AS REQUIRED;
f. THE SITE SUPERINTENDENT RESPONSIBLE FOR DAY-TO-DAY SITE OPERATIONS SHALL BE THE SPILL PREVENTION AND CLEANUP COORDINATOR.

- E. VEHICLE FUELING AND MAINTENANCE PRACTICE:
a. CONTRACTOR SHALL MAKE AN EFFORT TO PERFORM EQUIPMENT/VEHICLE FUELING AND MAINTENANCE AT AN OFF-SITE FACILITY;
b. CONTRACTOR SHALL PROVIDE AN ON-SITE FUELING AND MAINTENANCE AREA THAT IS CLEAN AND DRY;
c. IF POSSIBLE THE CONTRACTOR SHALL KEEP AREA COVERED;
d. CONTRACTOR SHALL KEEP A SPILL KIT AT THE FUELING AND MAINTENANCE AREA;
e. CONTRACTOR SHALL REGULARLY INSPECT VEHICLES FOR LEAKS AND DAMAGE;
f. CONTRACTOR SHALL USE DRIP PANS, DRIP CLOTHS, OR ABSORBENT PADS WHEN REPLACING SPENT FLUID.

EROSION CONTROL OBSERVATIONS AND MAINTENANCE PRACTICES

- 1. THIS PROJECT EXCEEDS ONE (1) ACRE OF DISTURBANCE AND THUS REQUIRES A SWPPP. THE SWPPP SHALL BE PREPARED BY THE CONTRACTOR. THE CONTRACTOR SHALL BE FAMILIAR WITH THE SWPPP AND KEEP AN UPDATED COPY OF THE SWPPP ON SITE AT ALL TIMES.
2. THE FOLLOWING REPRESENTS THE GENERAL OBSERVATION AND REPORTING PRACTICES THAT SHALL BE FOLLOWED AS PART OF THIS PROJECT:
A. OBSERVATIONS OF THE PROJECT FOR COMPLIANCE WITH THE SWPPP SHALL BE MADE BY THE CONTRACTOR AT LEAST ONCE A WEEK OR WITHIN 24 HOURS OF A STORM 0.25 INCHES OR GREATER;
B. AN OBSERVATION REPORT SHALL BE MADE AFTER EACH OBSERVATION AND DISTRIBUTED TO THE ENGINEER, THE OWNER, AND THE CONTRACTOR;
C. A REPRESENTATIVE OF THE SITE CONTRACTOR, SHALL BE RESPONSIBLE FOR MAINTENANCE AND REPAIR ACTIVITIES;
D. IF A REPAIR IS NECESSARY, IT SHALL BE INITIATED WITHIN 24 HOURS OF REPORT.

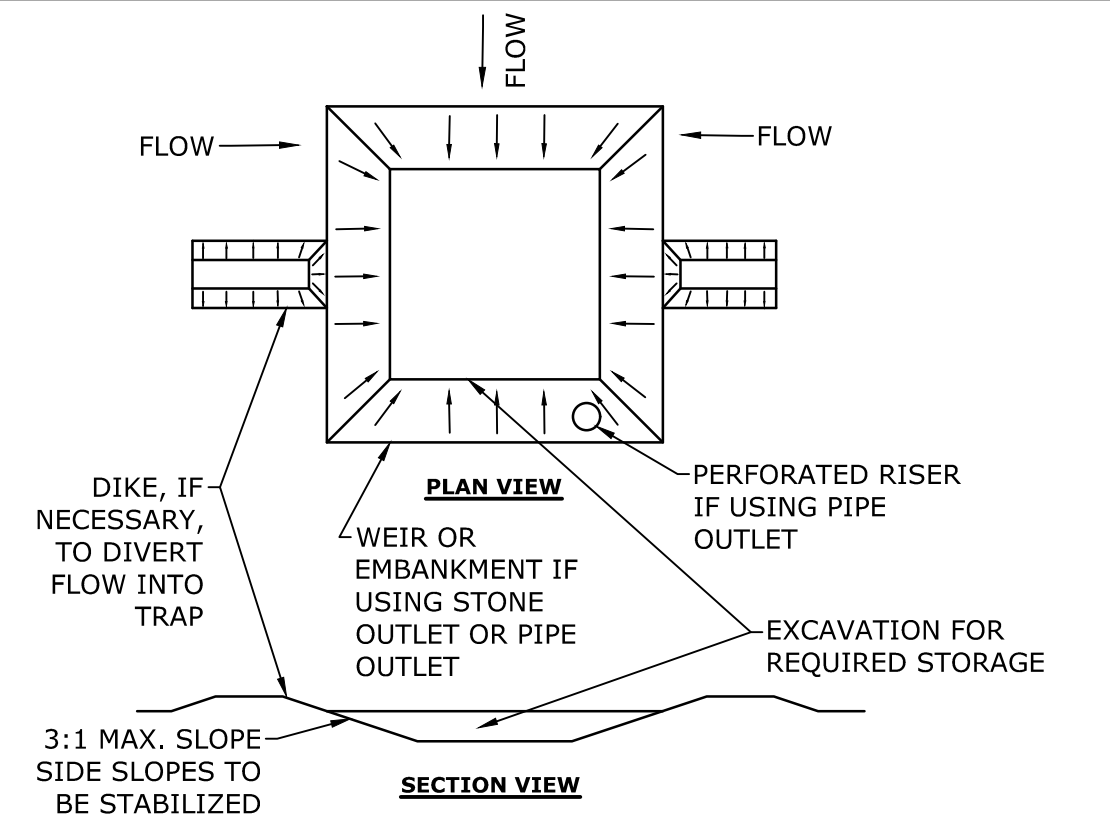

NOTES:

- 1. THE TRAP SHALL BE INSTALLED AS CLOSE TO THE DISTURBED AREA AS POSSIBLE.
2. THE MAXIMUM CONTRIBUTING AREA TO A SINGLE TRAP SHALL BE LESS THAN 5 ACRES.
3. THE MINIMUM VOLUME OF THE TRAP SHALL BE 3,600 CUBIC FEET OF STORAGE FOR EACH ACRE OF DRAINAGE AREA.
4. TRAP OUTLET SHALL BE MINIMUM OF ONE FOOT BELOW THE CREST OF THE TRAP.
5. TRAP SHALL DISCHARGE TO A STABILIZED AREA.
6. TRAP SHALL BE CLEANED WHEN 50 PERCENT OF THE ORIGINAL VOLUME IS FILLED.
7. MATERIALS REMOVED FROM THE TRAP SHALL BE PROPERLY DISPOSED OF AND STABILIZED.
8. SEDIMENT TRAPS MUST BE USED AS NEEDED TO CONTAIN RUNOFF UNTIL SOILS ARE STABILIZED.

SEDIMENT TRAP

NO SCALE

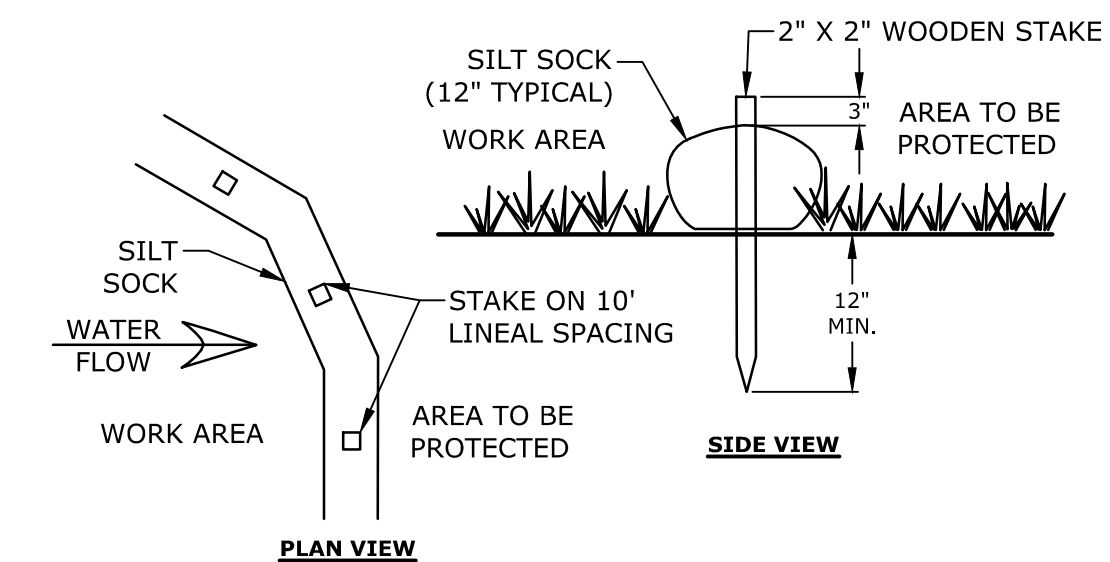

NOTES:

- 1. SILT SOCK SHALL BE SILT SOXX BY FILTREXX OR APPROVED EQUAL
2. INSTALL SILT SOCK IN ACCORDANCE WITH MANUFACTURER'S SPECIFICATIONS

SILT SOCK

NO SCALE

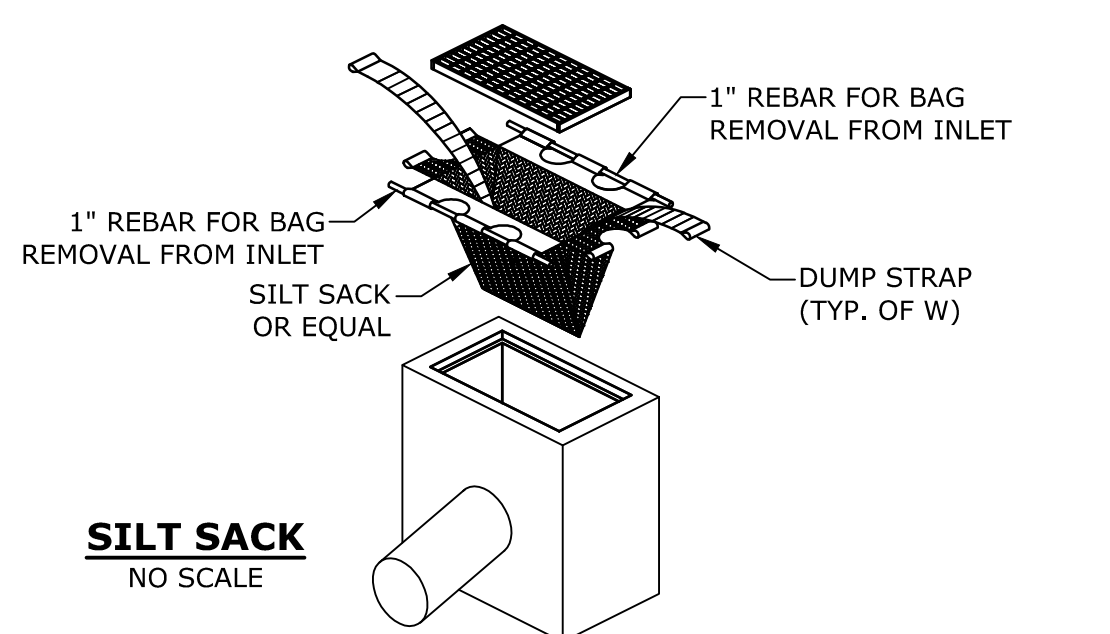

SILT SACK

NO SCALE

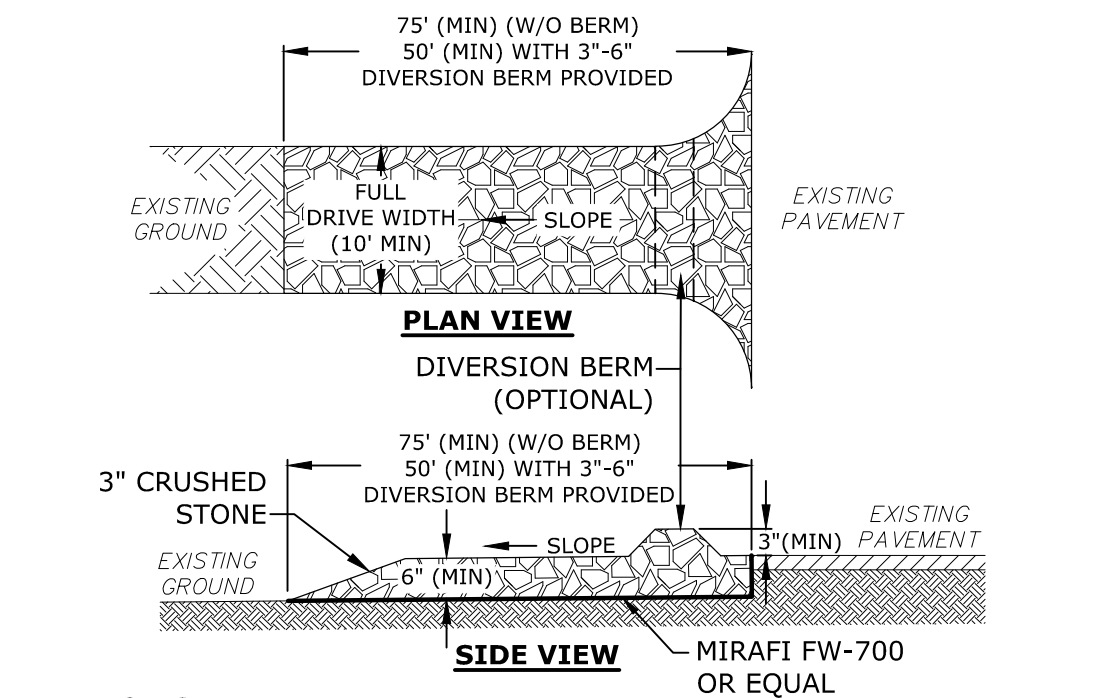

NOTES:

- 1. THE ENTRANCE SHALL BE MAINTAINED IN A CONDITION WHICH WILL PREVENT TRACKING OF SEDIMENT FROM THE SITE. WHEN WASHING IS REQUIRED, IT SHALL BE DONE SO RUNOFF DRAINS INTO AN APPROVED SEDIMENT TRAPPING DEVICE. ALL SEDIMENT SHALL BE PREVENTED FROM ENTERING STORM DRAINS, DITCHES, OR WATERWAYS

STABILIZED CONSTRUCTION EXIT

NO SCALE

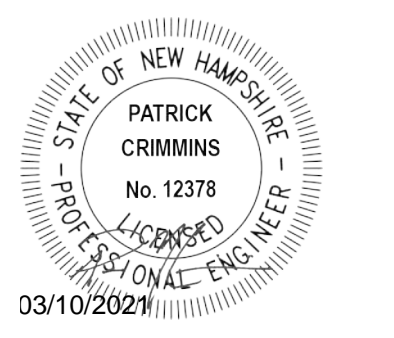

Proposed Multi-Family Development

Iron Horse Properties, LLC

105 Bartlett Street Portsmouth, New Hampshire

Table with 3 columns: MARK, DATE, DESCRIPTION. Rows include submission dates and descriptions like 'PB Submission', 'TAC Resubmission', 'Wetland CUP Resubmission', etc.

Table with 2 columns: PROJECT NO., DATE, FILE, DRAWN BY, CHECKED, APPROVED. Values include C-0960-006, April 20, 2020, C-0960-006_C-DTLS.DWG, NAH, PMC, BML.

DETAILS SHEET

SCALE: AS SHOWN

C-501

Vertical text on the left margin: Last Saved: 3/9/2021 10:50pm By: N.Hansens Plotted On: Mar 09, 2021 1:45:00pm By: F.C. Cabanero... Figures: AutoCAD, Sheet: C-0960-006, C-DTLS.dwg

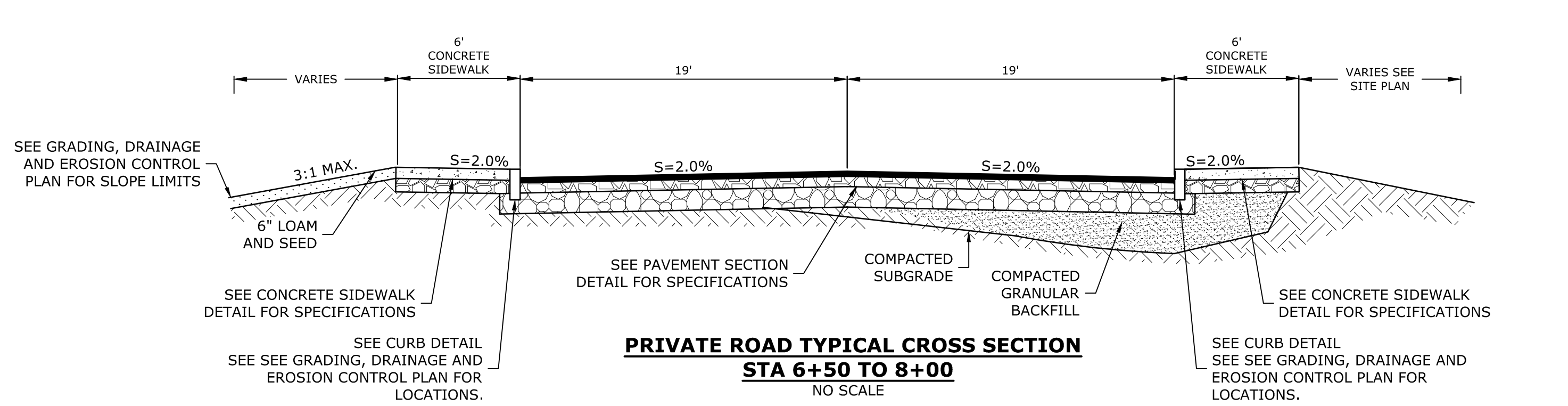
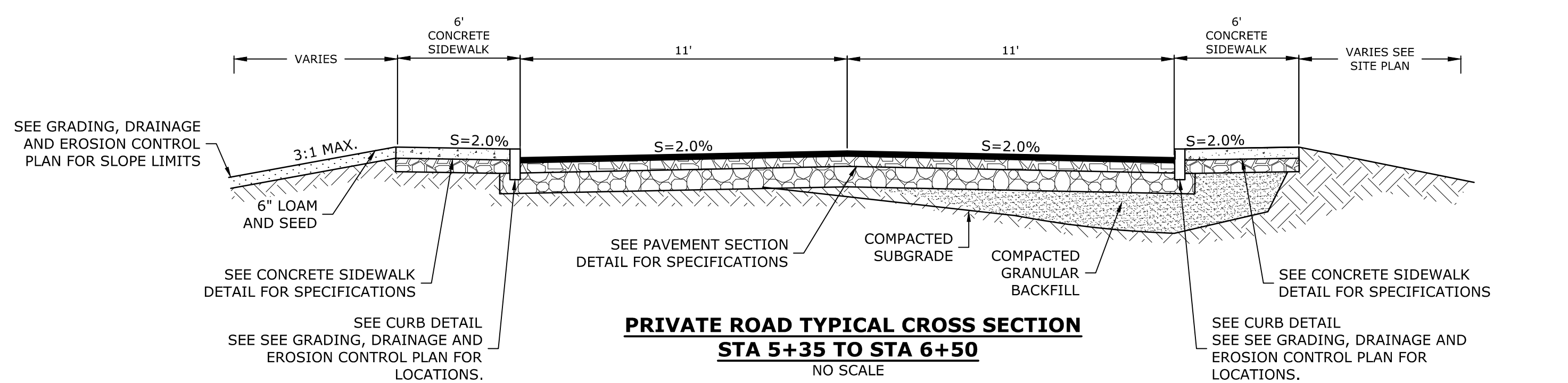
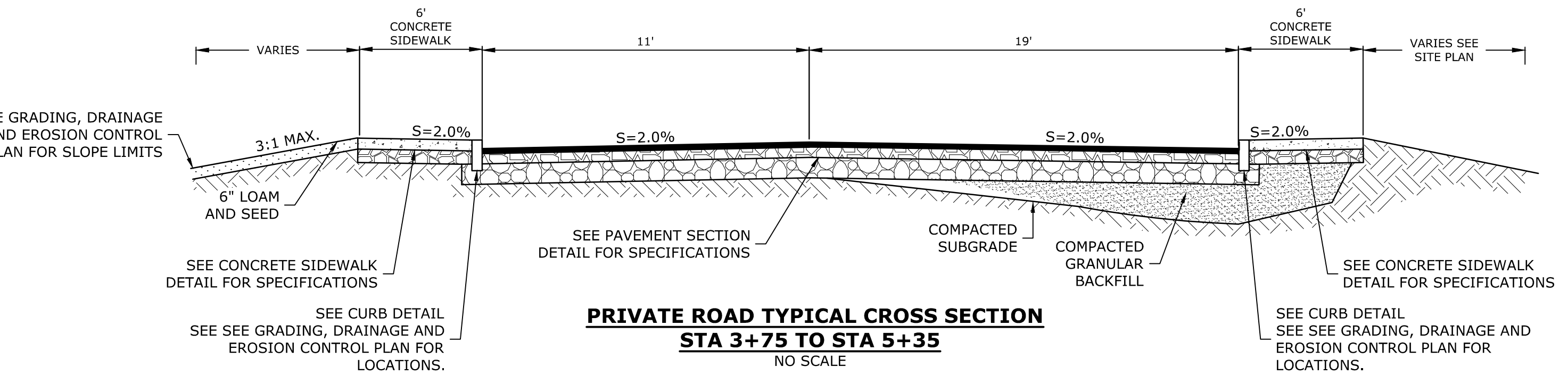
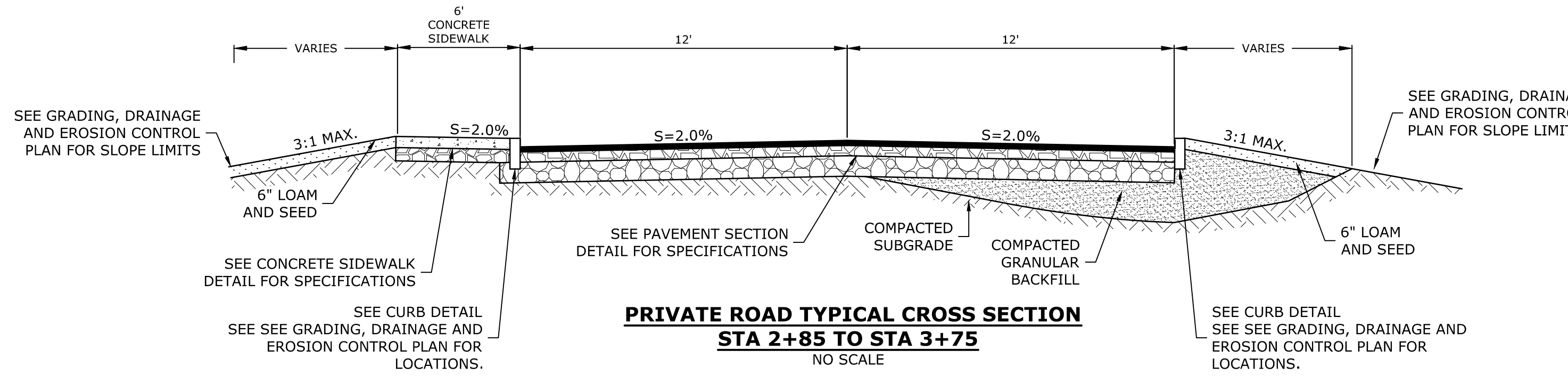
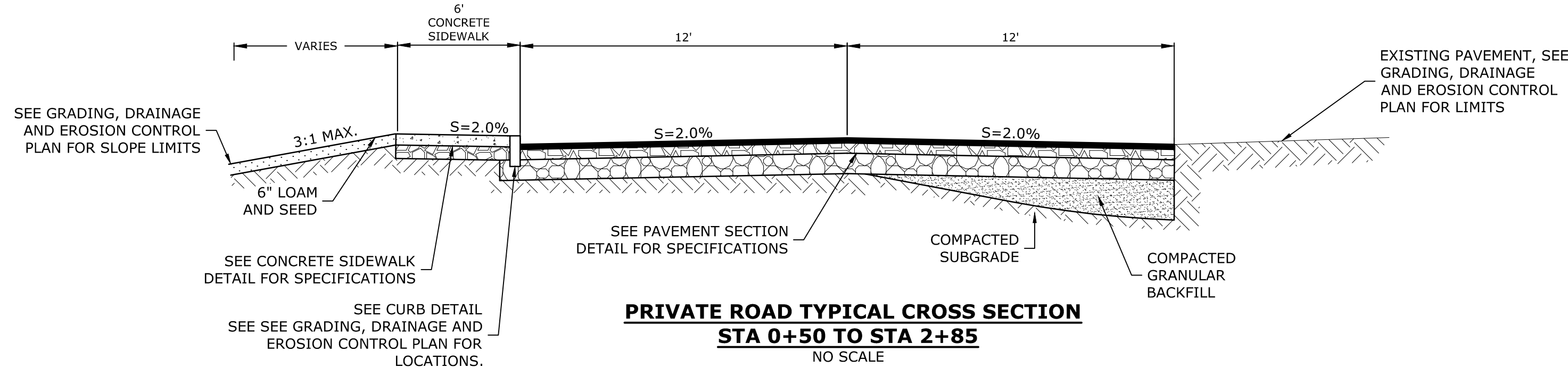

NHDOT ITEM No. 304.2 (GRAVEL)		NHDOT ITEM No. 304.3 (CRUSHED GRAVEL)	
SIEVE SIZE	% PASSING	SIEVE SIZE	% PASSING
6"	100	3"	100
#4	25-70	2"	95-100
#200	0-12	1"	55-85
		#4	27-52
		#200	0-12

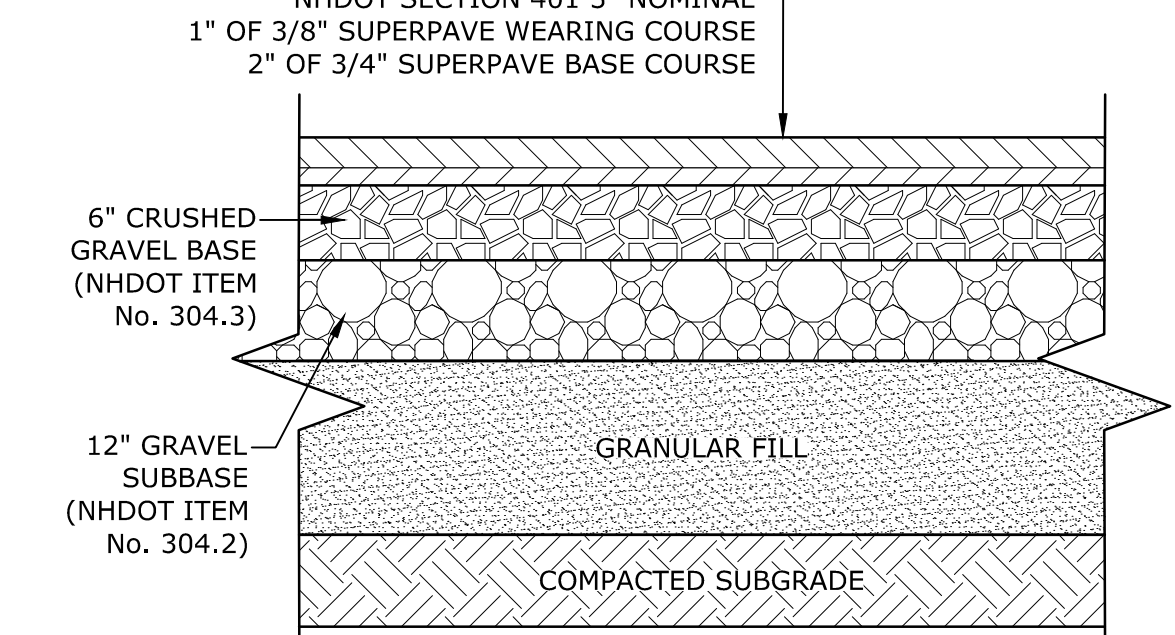

- NOTES:
- COORDINATE FINAL DESIGN SECTION WITH GEOTECHNICAL ENGINEER.
 - SEE SITE PLAN FOR PAVEMENT WIDTH AND LOCATION.
 - SEE GRADING, DRAINAGE AND EROSION CONTROL PLAN FOR PAVEMENT SLOPE AND CROSS-SLOPE.
 - A TACK COAT SHALL BE PLACED ON TOP OF BINDER COURSE PAVEMENT PRIOR TO PLACING WEARING COURSE.
 - REFER TO CITY SPECIFICATIONS FOR ASPHALT MIX DESIGN.

NHDOT ITEM No. 304.2 (GRAVEL)		NHDOT ITEM No. 304.3 (CRUSHED GRAVEL)	
SIEVE SIZE	% PASSING	SIEVE SIZE	% PASSING
6"	100	3"	100
#4	25-70	2"	95-100
#200	0-12	1"	55-85
		#4	27-52
		#200	0-12

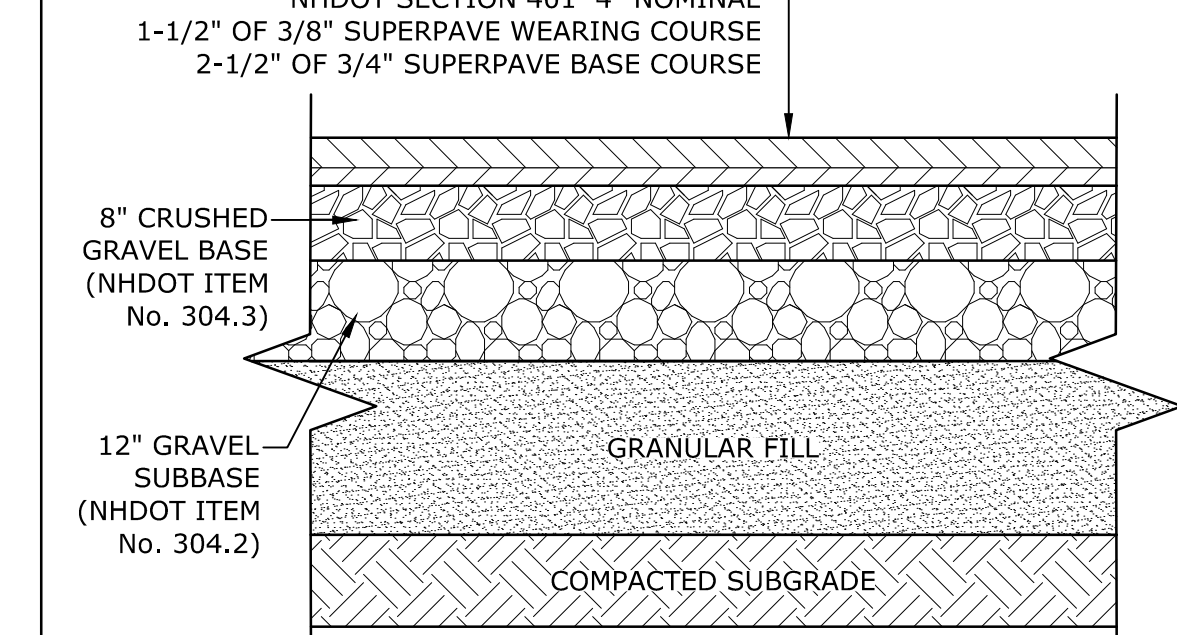

- NOTES:
- COORDINATE FINAL DESIGN SECTION WITH GEOTECHNICAL ENGINEER.
 - SEE SITE PLAN FOR PAVEMENT WIDTH AND LOCATION.
 - SEE GRADING, DRAINAGE AND EROSION CONTROL PLAN FOR PAVEMENT SLOPE AND CROSS-SLOPE.
 - A TACK COAT SHALL BE PLACED ON TOP OF BINDER COURSE PAVEMENT PRIOR TO PLACING WEARING COURSE.
 - REFER TO CITY SPECIFICATIONS FOR ASPHALT MIX DESIGN.

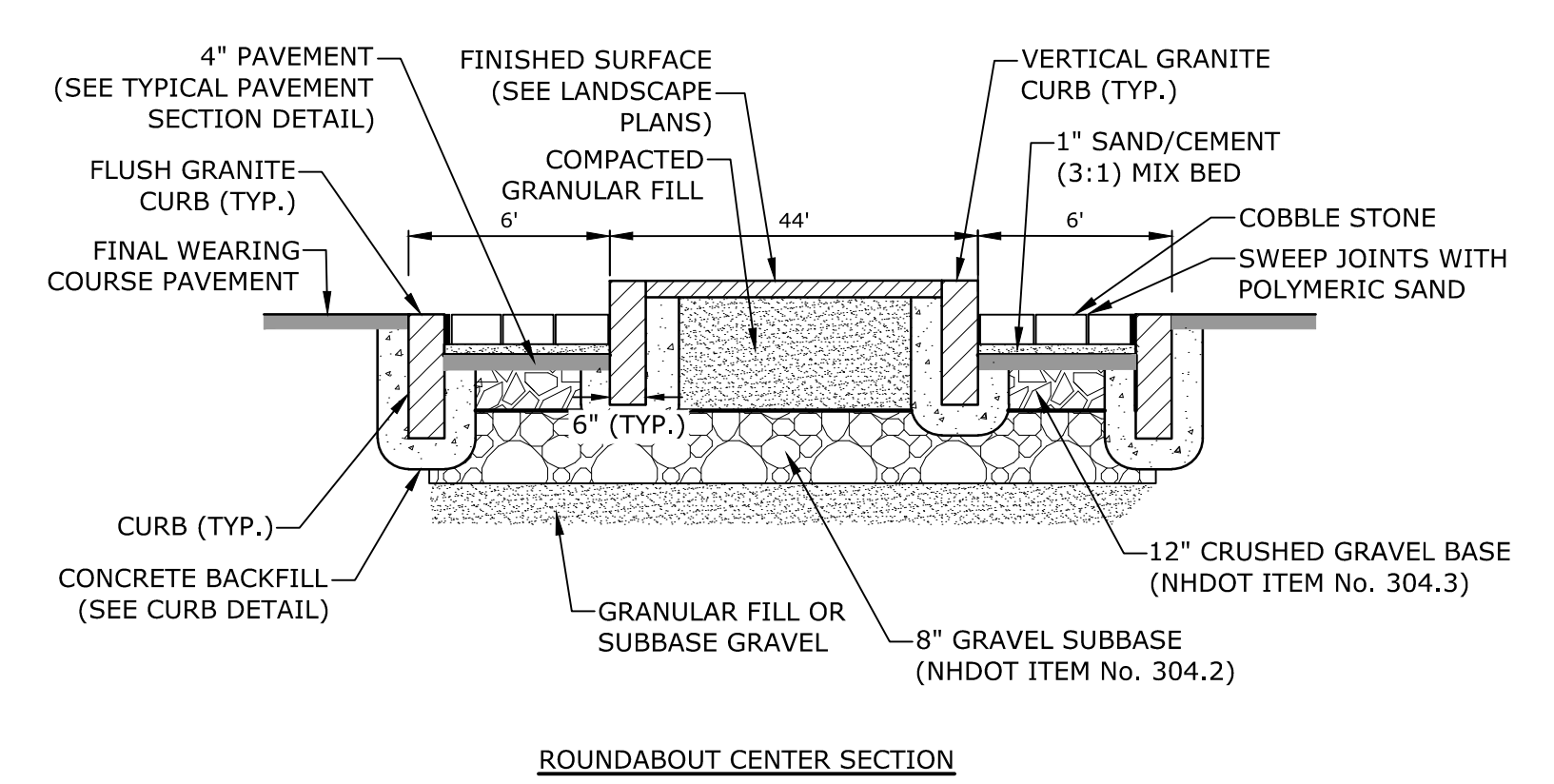
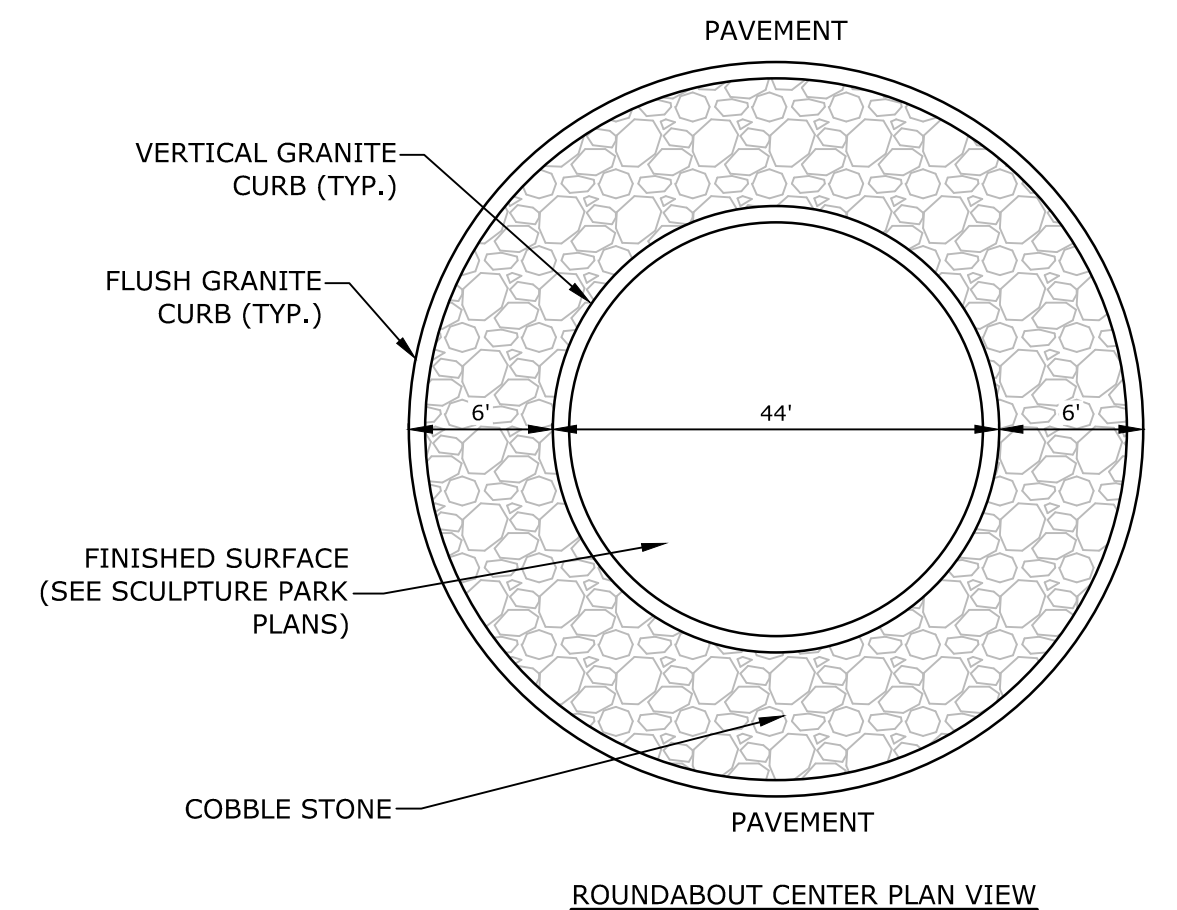

- NOTES:
- BEDDING MATERIAL SHALL BE A SAND/CEMENT MIX THAT IS 3 PARTS SAND AND 1 PART CEMENT. SAND SHALL CONFORM WITH ASTM C33 AND CEMENT SHALL BE PORTLAND CEMENT TYPE I/TYPE II.

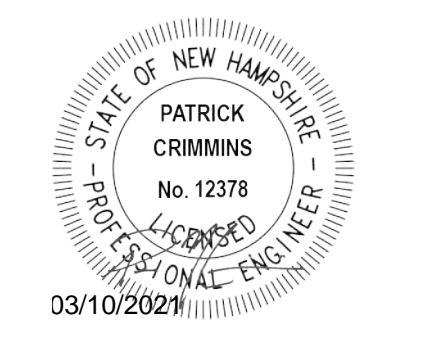

Proposed Multi-Family Development

Iron Horse Properties, LLC

**105 Bartlett Street
Portsmouth,
New Hampshire**

MARK	DATE	DESCRIPTION
I	3/10/2021	PB Submission
H	1/20/2021	TAC Resubmission
G	11/18/2020	TAC Resubmission
F	10/28/2020	Wetland CUP Resubmission
E	5/20/2020	TAC Resubmission
D	4/29/2020	Wetland CUP Submission
C	4/20/2020	TAC Submission
B	2/6/2020	Design Review Submission
A	1/2/2020	ZBA Submission

PROJECT NO: C-0960-006
DATE: April 20, 2020
FILE: C-0960-006_C-DTLS.DWG
DRAWN BY: NAH
CHECKED: PMC
APPROVED: BML

DETAILS SHEET

SCALE: AS SHOWN

C-502

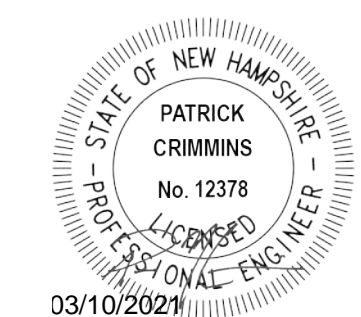
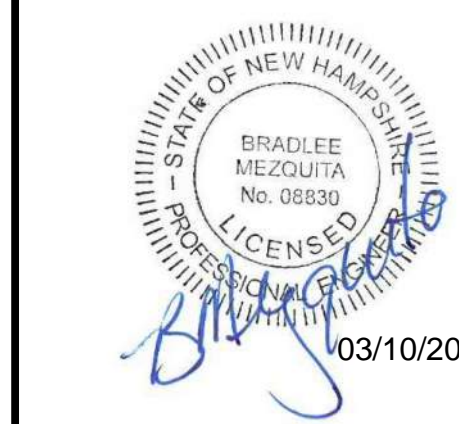

Proposed Multi-Family Development

Iron Horse Properties, LLC

105 Bartlett Street
Portsmouth,
New Hampshire

I	3/10/2021	PB Submission
H	1/20/2021	TAC Resubmission
G	11/18/2020	TAC Resubmission
F	10/28/2020	Wetland CUP Resubmission
E	5/20/2020	TAC Resubmission
D	4/29/2020	Wetland CUP Submission
C	4/20/2020	TAC Submission
B	2/6/2020	Design Review Submission
A	1/2/2020	ZBA Submission
MARK	DATE	DESCRIPTION

PROJECT NO: C-0960-008
DATE: April 20, 2020
FILE: C-0960-008_C-DTLS.DWG
DRAWN BY: NAH
CHECKED: PMC
APPROVED: BML

DETAILS SHEET

SCALE: AS SHOWN

C-503

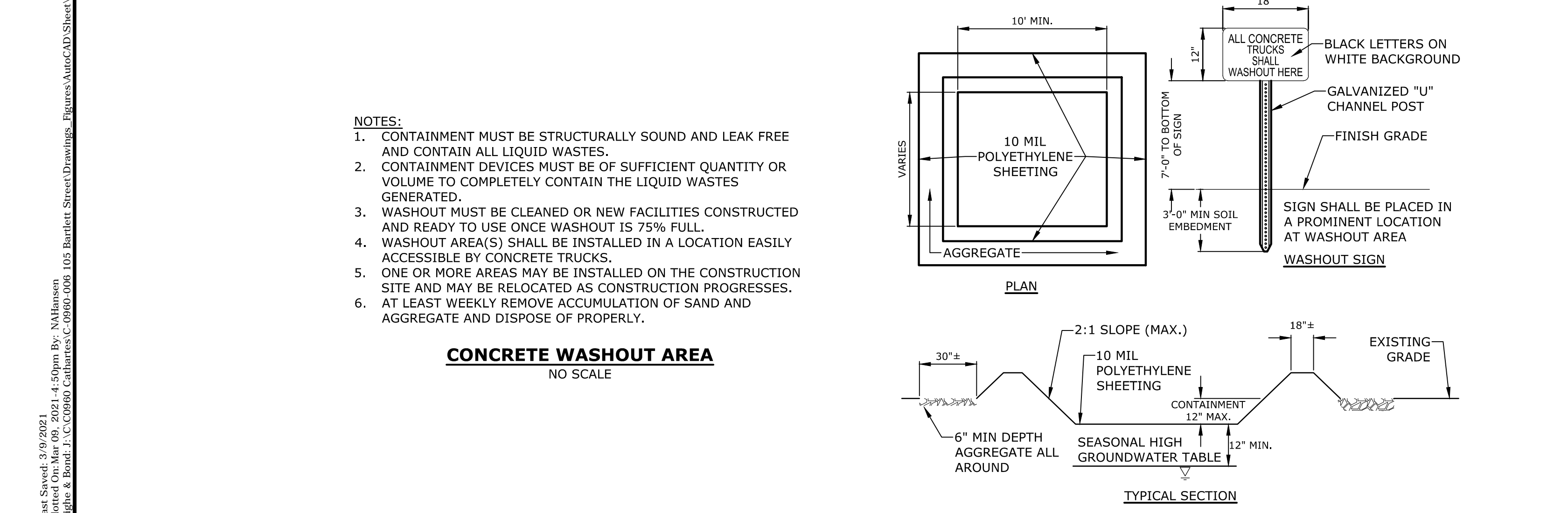
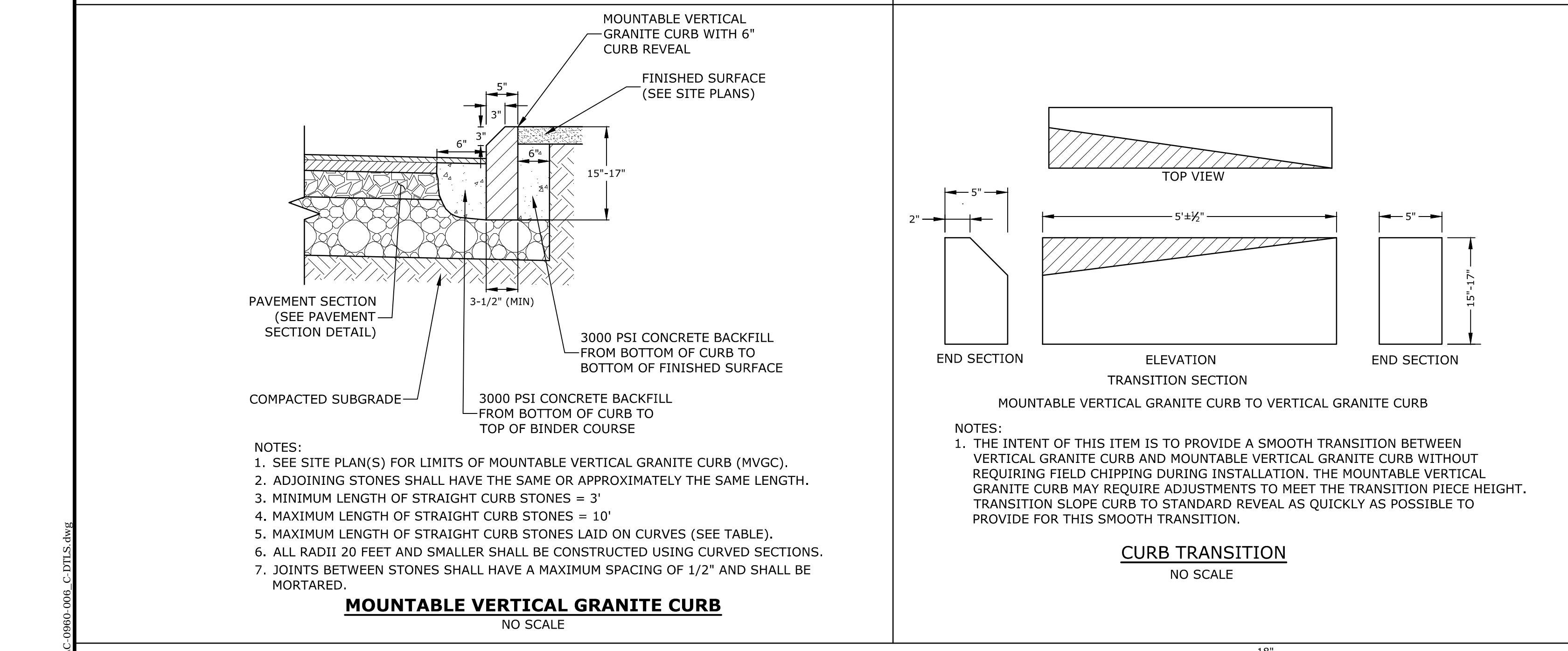
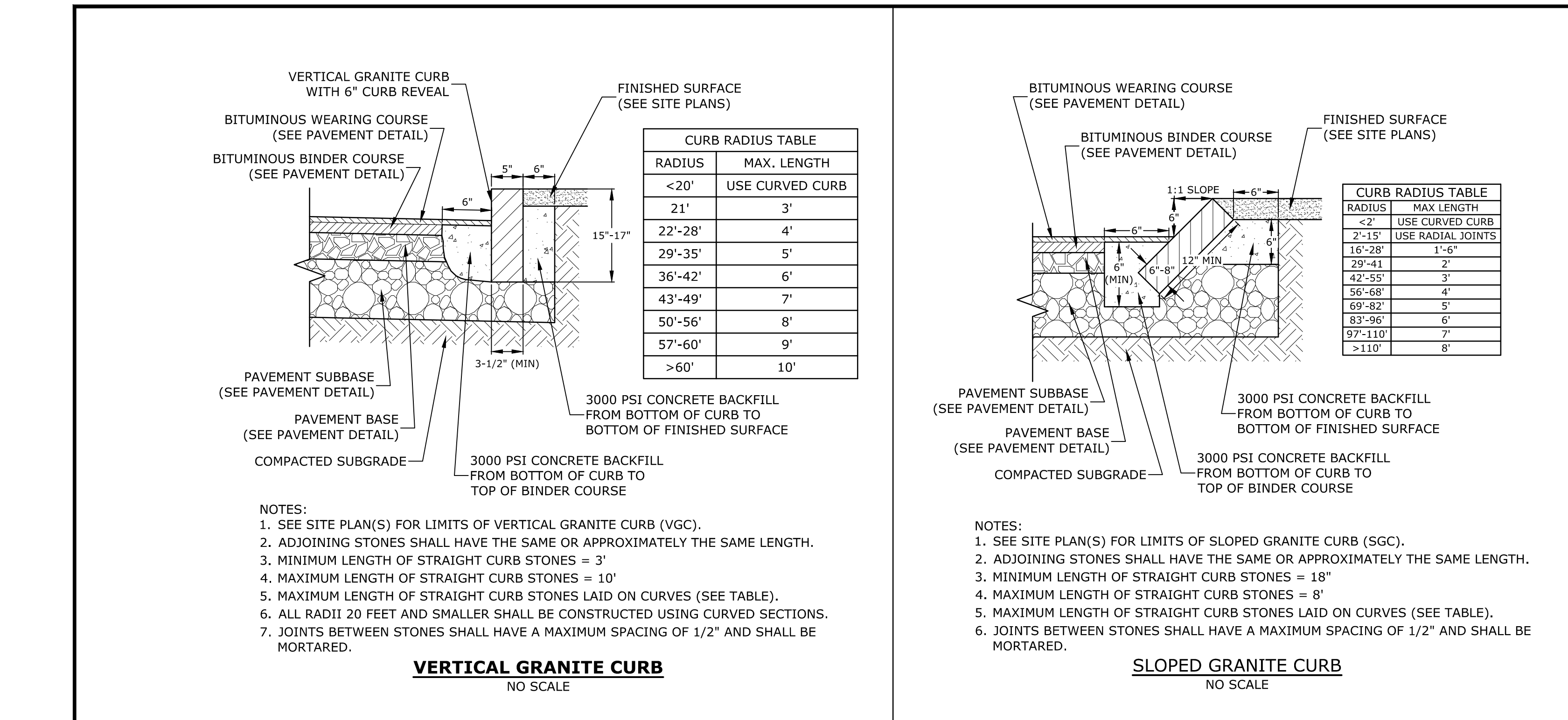
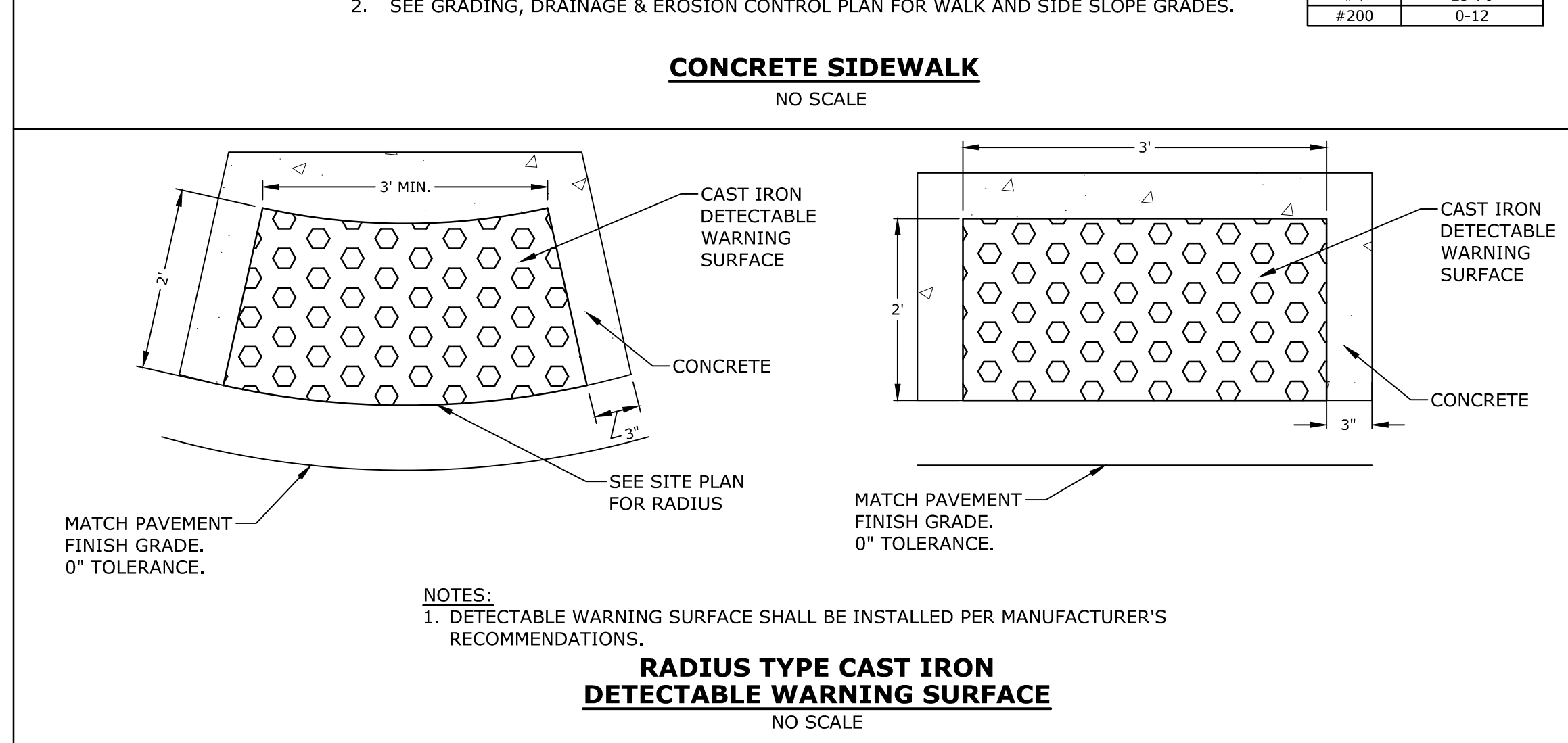
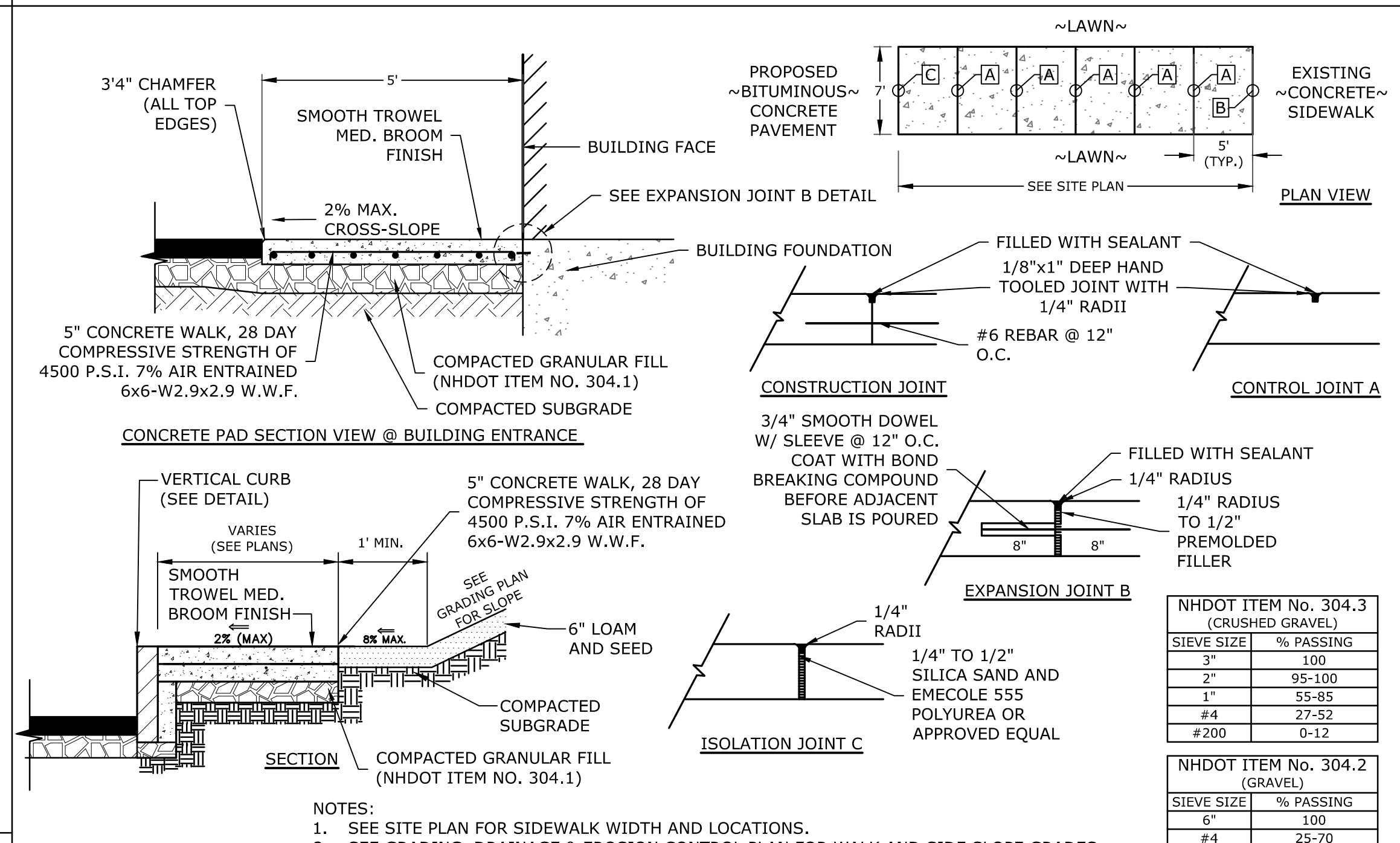
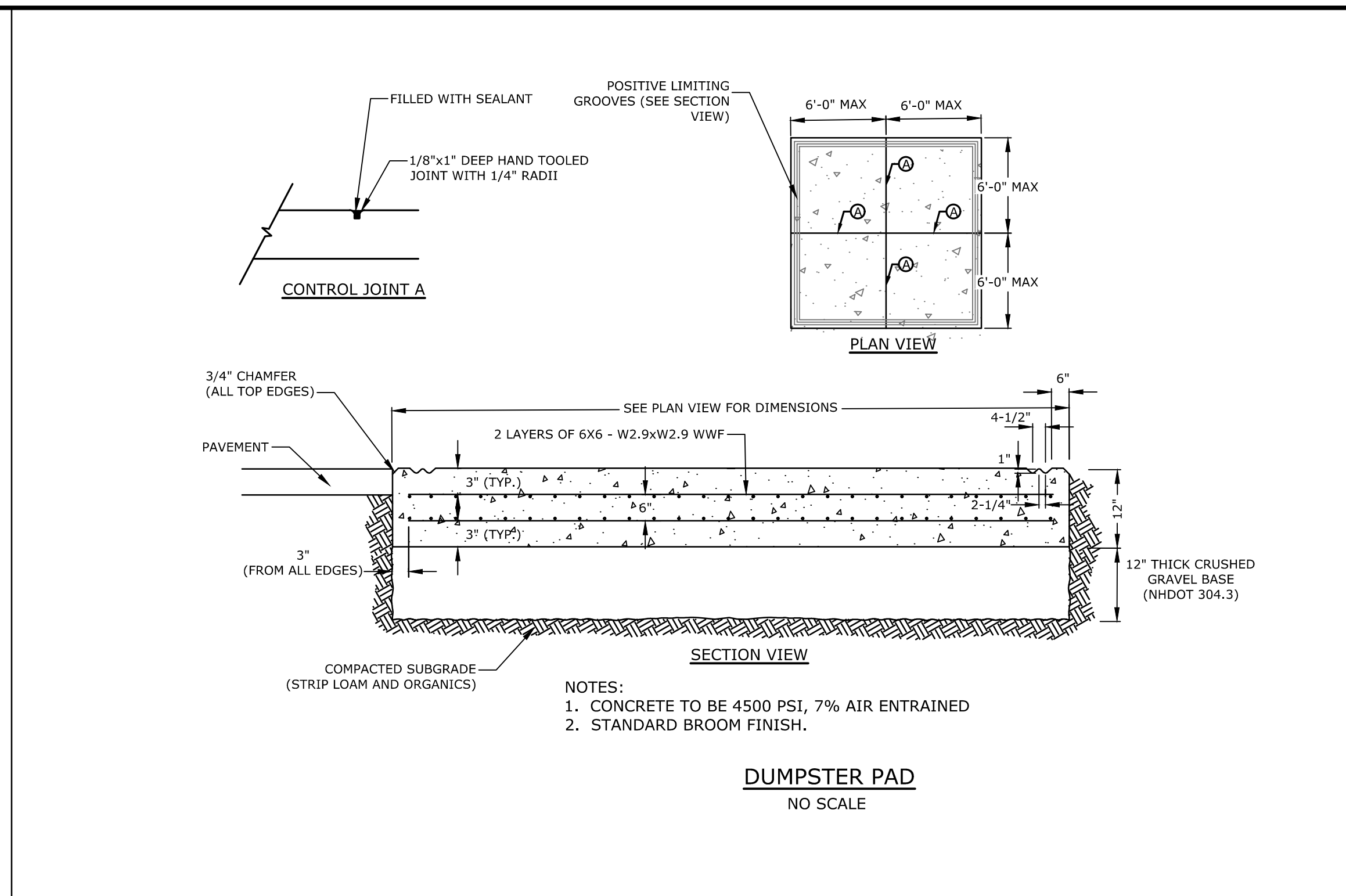

Last Saved: 3/9/2021
 Plotted On: Mar 09, 2021
 Tighe & Bond, F.C. Collins, C. 0960-008, 105 Bartlett Street Drawings, Figures AutoCAD, Sheet: C-0960-008, C-DTLS.dwg

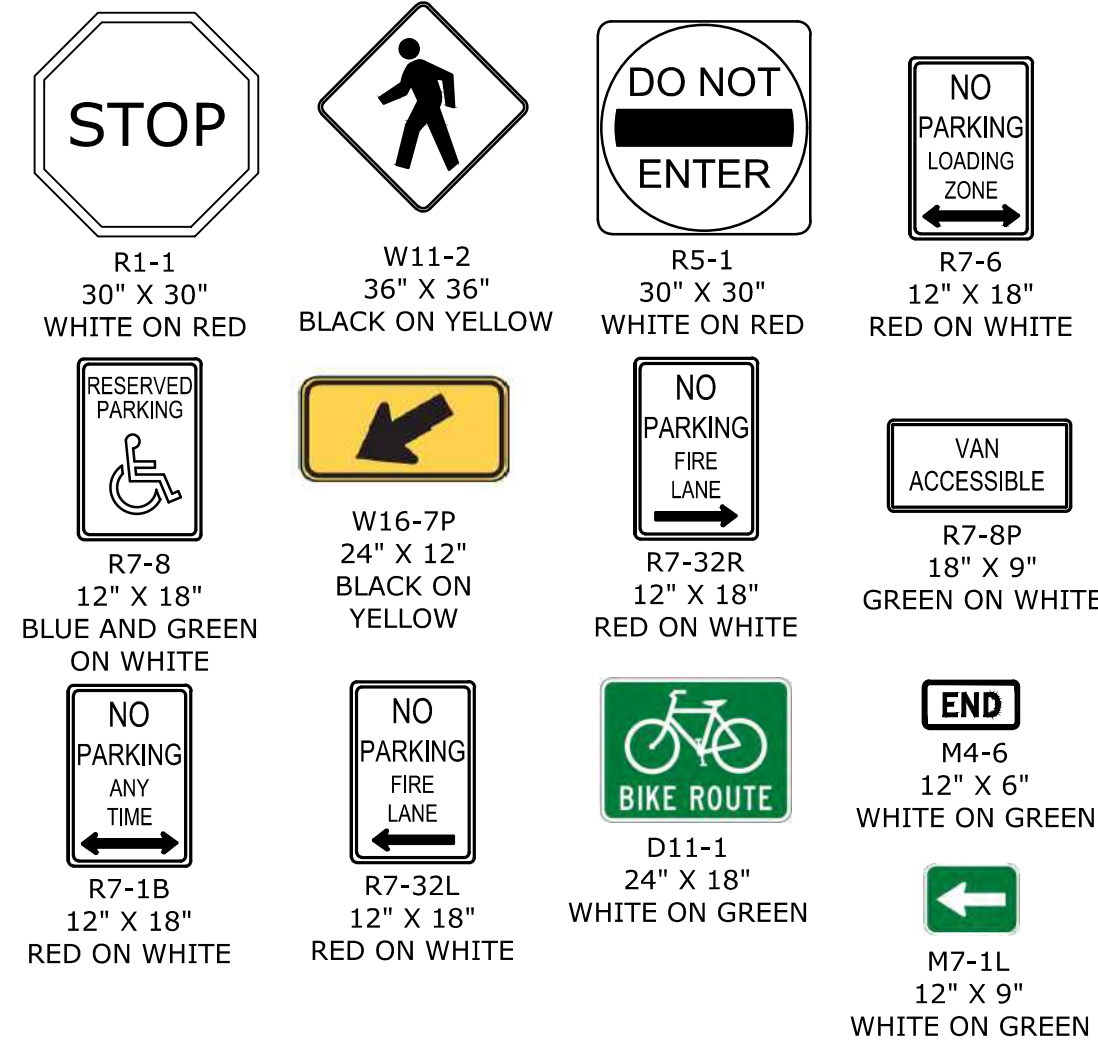

NOTES:
 ALL SIGNS TO BE INSTALLED AS INDICATED IN THE MANUAL ON UNIFORM TRAFFIC CONTROL DEVICES, LATEST EDITION.
POST: SCHEDULE 40 GALVANIZED STEEL PIPE (OUTSIDE DIA. = 2.375").
FINISH: POST TO BE POWDER COATED GLOSS BLACK
LENGTH: AS REQUIRED
WEIGHT PER LINEAR FOOT: 2.50 LBS (MIN.)
HOLES: 3/8" DIAMETER (AS REQUIRED)
STEEL: SHALL CONFORM TO ASTM A-499 (GRADE 60) OR ASTM A-576 (GRADE 1070-1080)

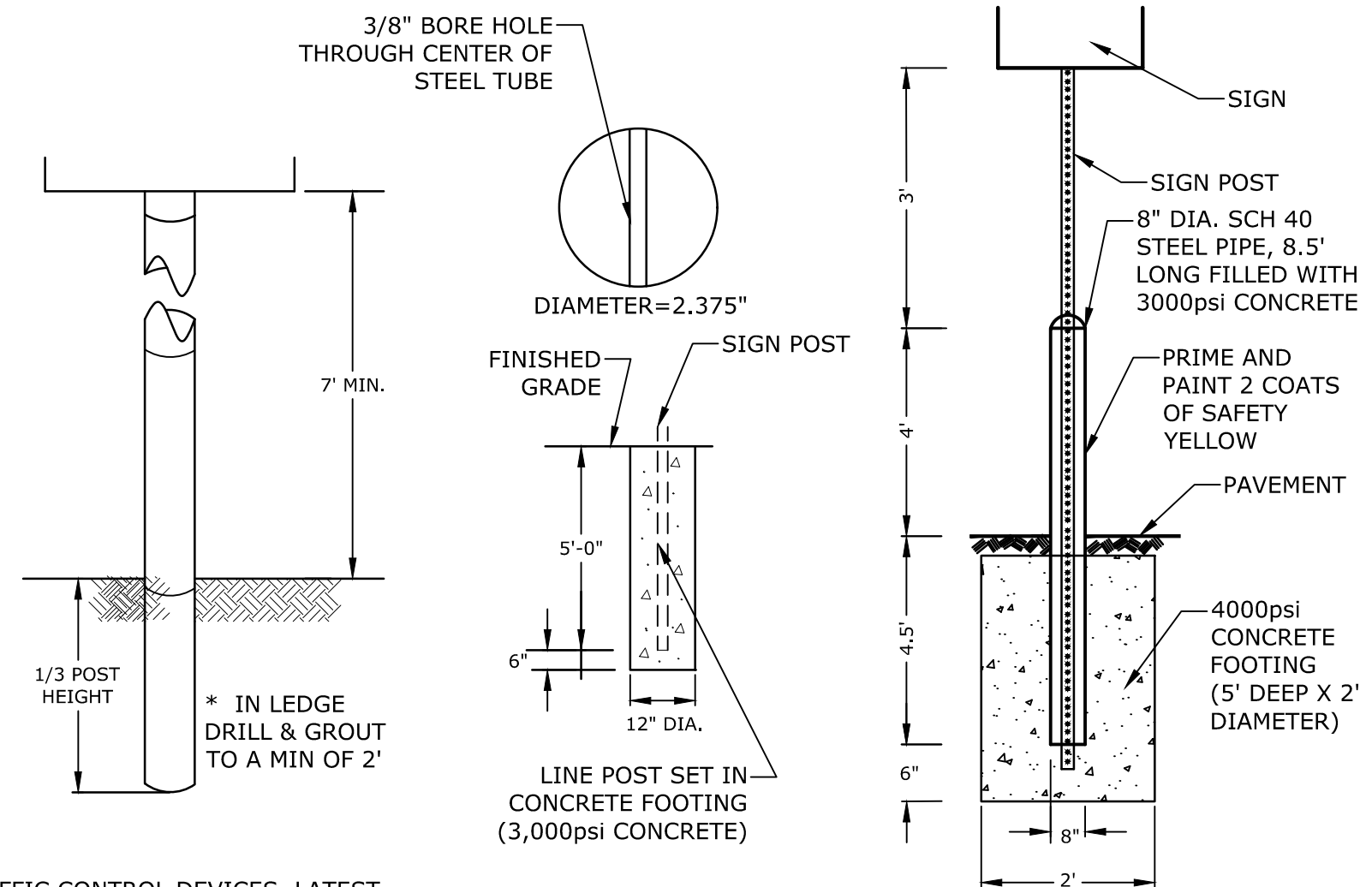

SIGN LEGEND & SIGN POST
NO SCALE

BOLLARD MOUNTED SIGN DETAIL
NO SCALE

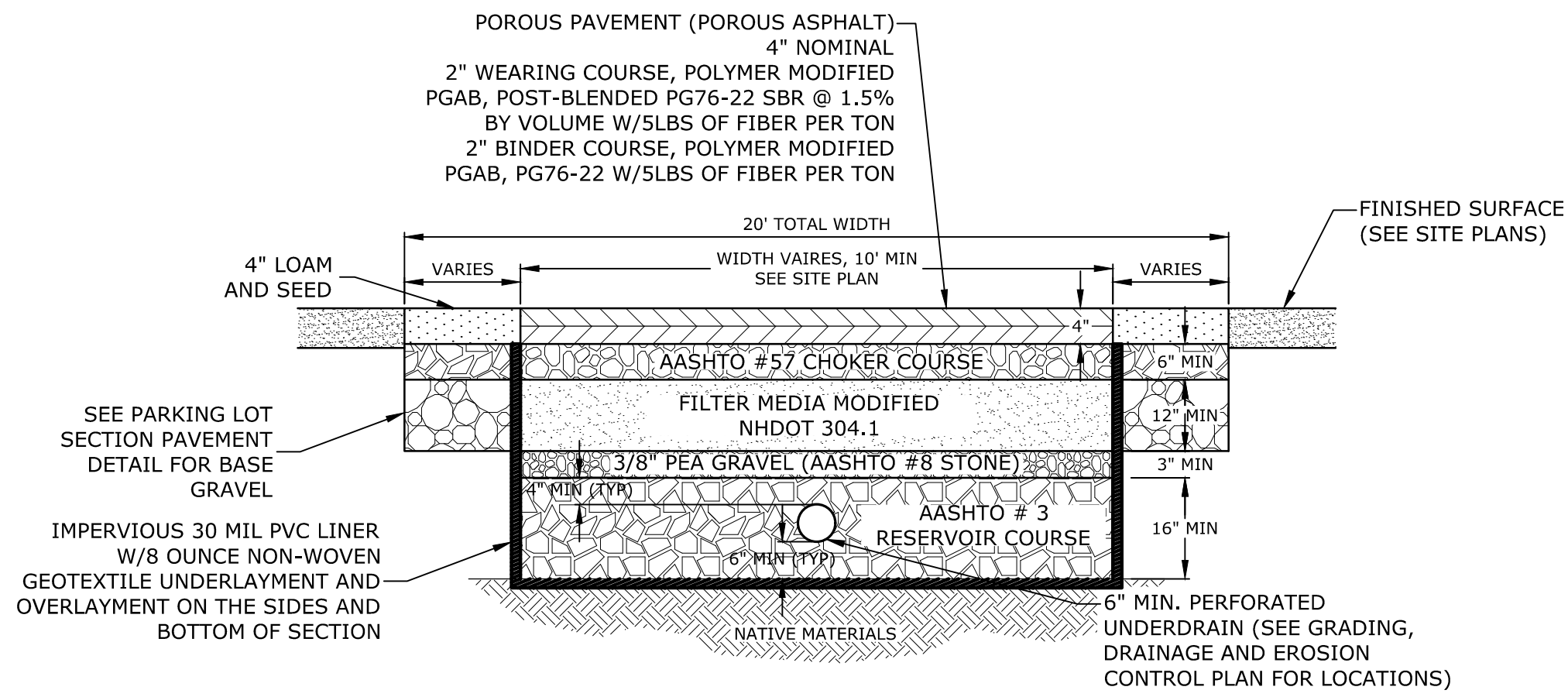

AASHTO #57 STONE (CHOKER COURSE)		MODIFIED NHDOT 304.1		AASHTO #8 STONE (PEA GRAVEL)		AASHTO #3 STONE (RESERVOIR COURSE)	
SIEVE SIZE	% PASSING	SIEVE SIZE	% PASSING	SIEVE SIZE	% PASSING	SIEVE SIZE	% PASSING
1 1/2"	100	6"	100	3/4"	100	2 1/2"	100
1"	95-100	#4	70-100	#4	85-100	2"	90-100
3/4"	25-60	#200	0-6*	#4	10-30	1 1/2"	35-70
#4	0-10			#8	0-10	1"	0-15
#8	0-5			#16	0-5	3/4"	0-5

*PREFERABLY <4%

- NOTES:**
- SEE GRADING, DRAINAGE, UTILITIES AND EROSION CONTROL PLAN FOR PAVEMENT SLOPE AND CROSS-SLOPE.
 - POROUS ASPHALT SHALL BE CONSTRUCTED IN ACCORDANCE WITH THE LATEST SPECIFICATIONS FROM THE UNH STORMWATER CENTER FOR POROUS ASPHALT.
 - POROUS ASPHALT MIX SPECIFIED IS RECOMMENDED BY THE UNH STORMWATER CENTER FOR SITES ANTICIPATING H-20 LOADING.
 - FILTER COURSE TO BE INCREASED AS NECESSARY TO MEET PROPOSED GRADES.
 - INSTALL FILTER COURSE AGGREGATE IN 8-INCH MAXIMUM LIFTS TO A MAXIMUM OF 95% STANDARD PROCTOR COMPACTION (ASTM D698 / AASHTO T99). INSTALL AGGREGATE TO GRADES INDICATED ON THE DRAWINGS.
 - INSTALL CHOKER, GRAVEL, AND STONE BASE COURSE AGGREGATE TO A MAXIMUM OF 95% COMPACTION STANDARD PROCTOR (ASTM D698 / AASHTO T99). CHOKER SHOULD BE PLACED EVENLY OVER SURFACE OF FILTER COURSE BED, SUFFICIENT TO ALLOW PLACEMENT OF PAVEMENT, AND NOTIFY ENGINEER FOR APPROVAL. CHOKER BASE COURSE THICKNESS SHALL BE SUFFICIENT TO ALLOW FOR EVEN PLACEMENT OF THE POROUS ASPHALT BUT NO LESS THAN 6-INCHES IN DEPTH.
 - THE DENSITY OF SUBBASE COURSES SHALL BE DETERMINED BY AASHTO T 191 (SAND-CONE METHOD), AASHTO T 204 (DRIVE CYLINDER METHOD), OR AASHTO T 238 (NUCLEAR METHODS), OR OTHER APPROVED METHODS AT THE DISCRETION OF THE SUPERVISING ENGINEER.

POROUS ASPHALT SECTION
NO SCALE

- NOTES:**
- RAMPS SHALL BE CONSTRUCTED IN ACCORDANCE WITH THE AMERICANS WITH DISABILITIES ACT AND LOCAL AND STATE REQUIREMENTS.
 - A 6" COMPACTED CRUSHED GRAVEL BASE (NHDOT ITEM No. 304.3) SHALL BE PROVIDED BENEATH RAMPS.
 - DETECTABLE WARNING PANEL SHALL BE CAST IRON SET IN CONCRETE (SEE DETAIL.)
 - PROVIDE DETECTABLE WARNING SURFACES ANYTIME THAT A CURB RAMP, BLENDED TRANSITION, OR LANDING CONNECTS TO A STREET.
 - LOCATE THE DETECTABLE WARNING SURFACES AT THE BACK OF THE CURB ALONG THE EDGE OF THE LANDING.
 - THE MAXIMUM RUNNING SLOPE OF ANY SIDEWALK CURB RAMP IS 12:1; THE MAXIMUM CROSS SLOPE IS 2%; THE SLOPE OF THE LANDING SHALL NOT EXCEED 2% IN ANY DIRECTION.
 - TRANSITIONS SHALL BE FLUSH AND FREE OF ABRUPT CHANGES. ROADWAY SHOULDER SLOPES ADJOINING SIDEWALK CURB RAMPS SHALL BE A MAXIMUM OF 5% (FULL WIDTH) FOR A DISTANCE OF 2 FT. FROM THE ROADWAY CURBLINE.
 - THE BOTTOM OF THE SIDEWALK CURB RAMP OR LANDING, EXCLUSIVE OF THE FLARED SIDES, SHALL BE WHOLLY CONTAINED WITHIN THE CROSSWALK MARKINGS.
 - DETECTABLE WARNING PANELS SHALL BE A MINIMUM OF 2 FEET IN DEPTH. THE ROWS OF TRUNCATED DOMES SHALL BE ALIGNED PERPENDICULAR TO THE GRADE BREAK BETWEEN THE RAMP, BLENDED TRANSITION, OR LANDING AND THE STREET.
 - THE TEXTURE OF THE DETECTABLE WARNING FEATURE MUST CONTRAST VISUALLY WITH THE SURROUNDING SURFACES (EITHER LIGHT-ON-DARK OR DARK-ON-LIGHT).

NHDOT ITEM No. 304.3 (CRUSHED GRAVEL)	
SIEVE SIZE	% PASSING
3"	100
2"	95-100
1"	55-85
#4	27-52
#200	0-12

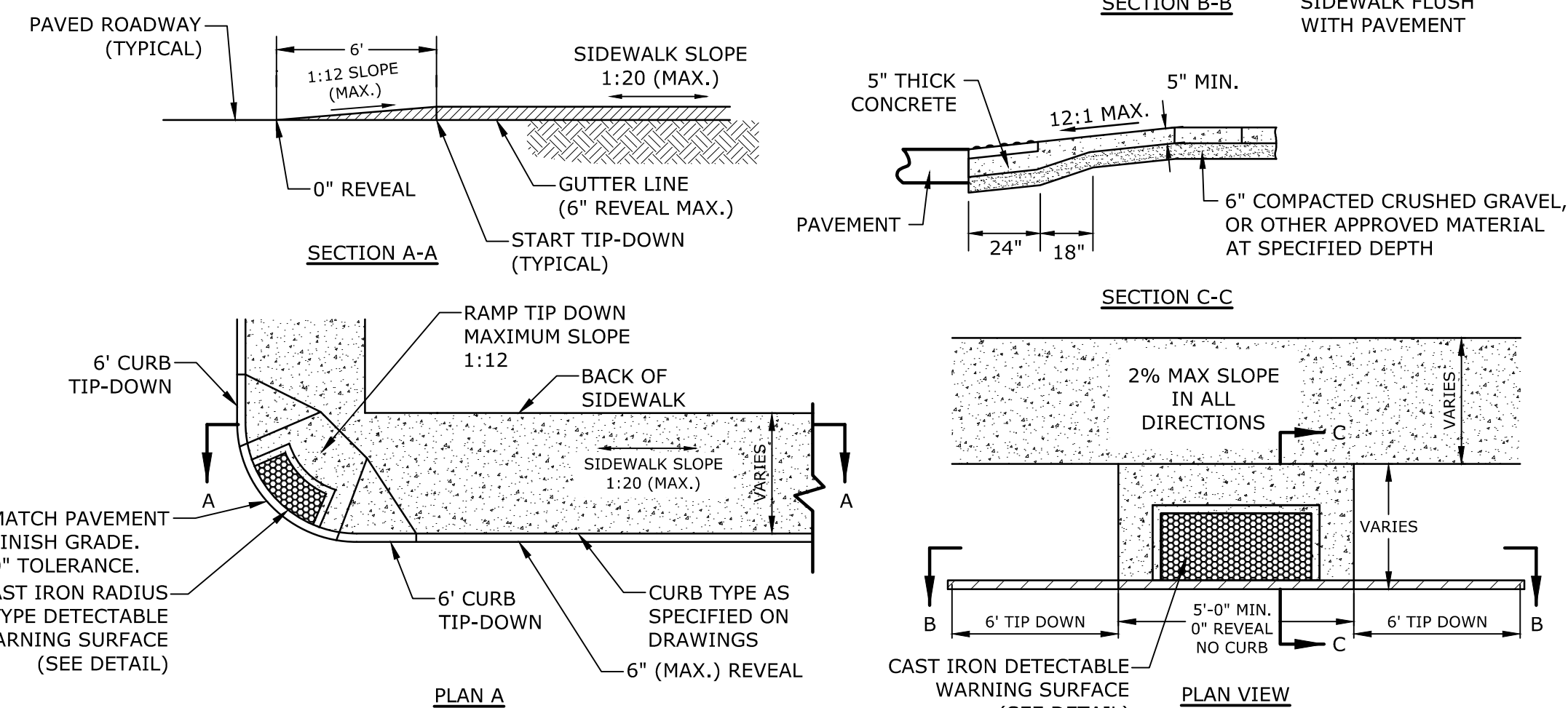

CONCRETE WHEELCHAIR ACCESSIBLE RAMP
NO SCALE

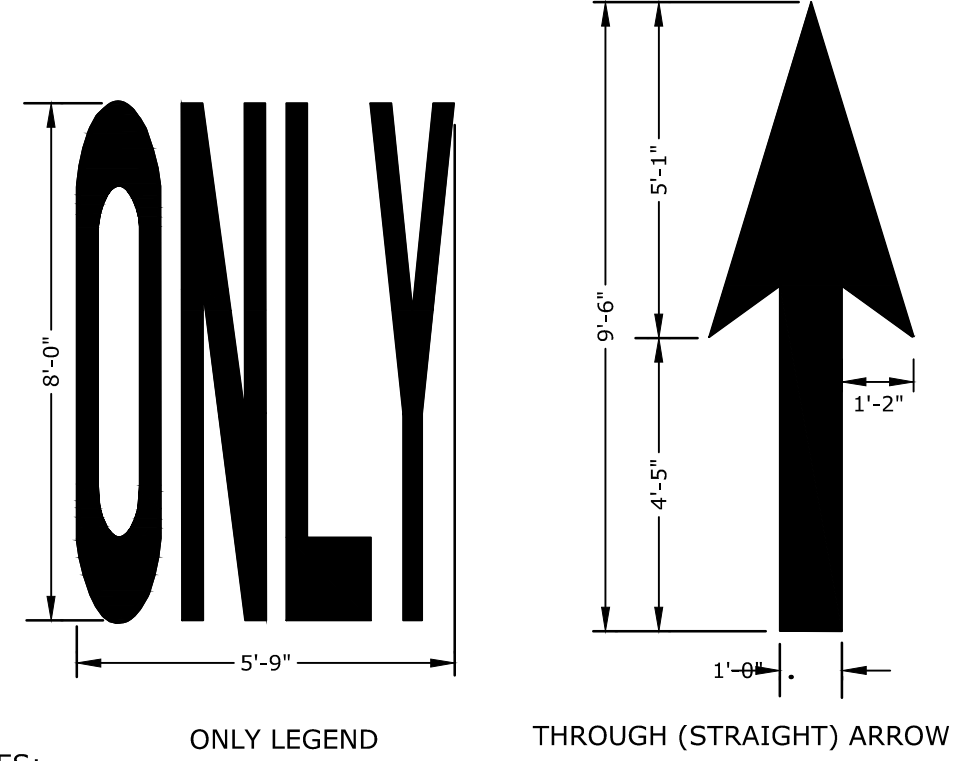

- NOTES:**
- ALL WORDS AND SYMBOLS SHALL BE RETROREFLECTIVE WHITE AND SHALL CONFORM TO THE LATEST VERSION OF THE MUTCD.
 - ALL PAINT SHALL BE FAST DRYING TRAFFIC PAINT, MEETING THE REQUIREMENTS OF AASHTO M248-TYPE F. PAINT SHALL BE APPLIED AS SPECIFIED BY MANUFACTURER.

DIRECTIONAL PAVEMENT MARKING DETAILS
NO SCALE

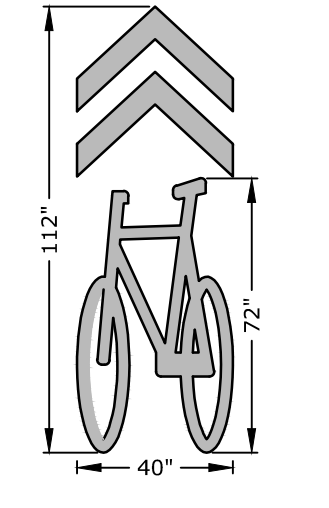

- NOTES:**
- PAVEMENT MARKINGS TO BE INSTALLED IN LOCATIONS AS SHOWN ON SITE PLAN.
 - MARKINGS SHALL BE CONSTRUCTED USING WHITE THERMO PLASTIC, REFLECTORIZED PAVEMENT MARKING MATERIAL MEETING THE REQUIREMENTS OF ASTM D 4505

"SHARROW" SHARED LANE MARKING
NO SCALE

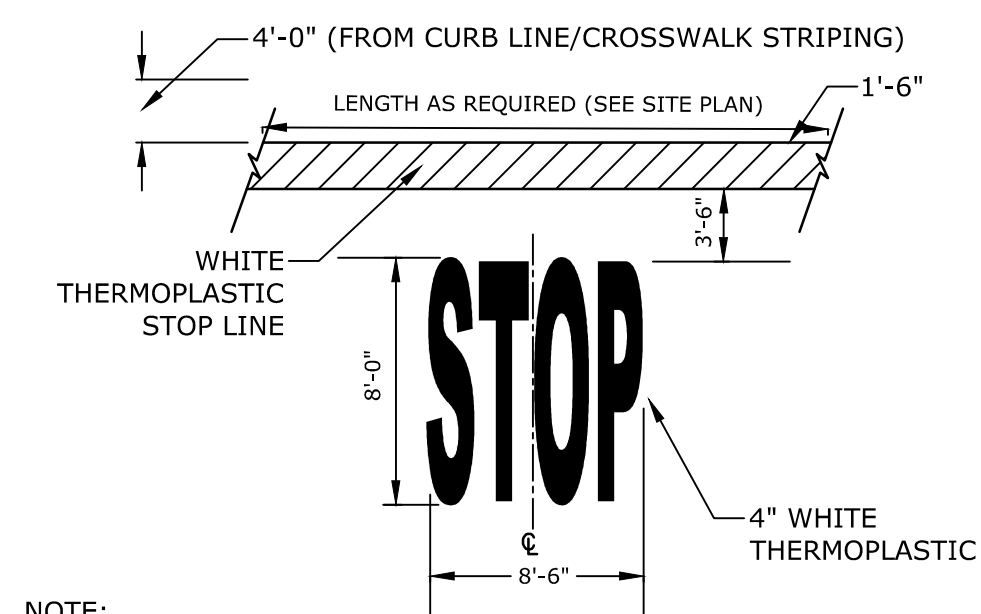

- NOTE:**
- PAVEMENT MARKINGS TO BE INSTALLED IN LOCATIONS AS SHOWN ON SITE PLAN.
 - STRIPING SHALL BE CONSTRUCTED USING WHITE THERMO PLASTIC, REFLECTORIZED PAVEMENT MARKING MATERIAL MEETING THE REQUIREMENTS OF ASTM D 4505

STOP BAR AND LEGEND
NO SCALE

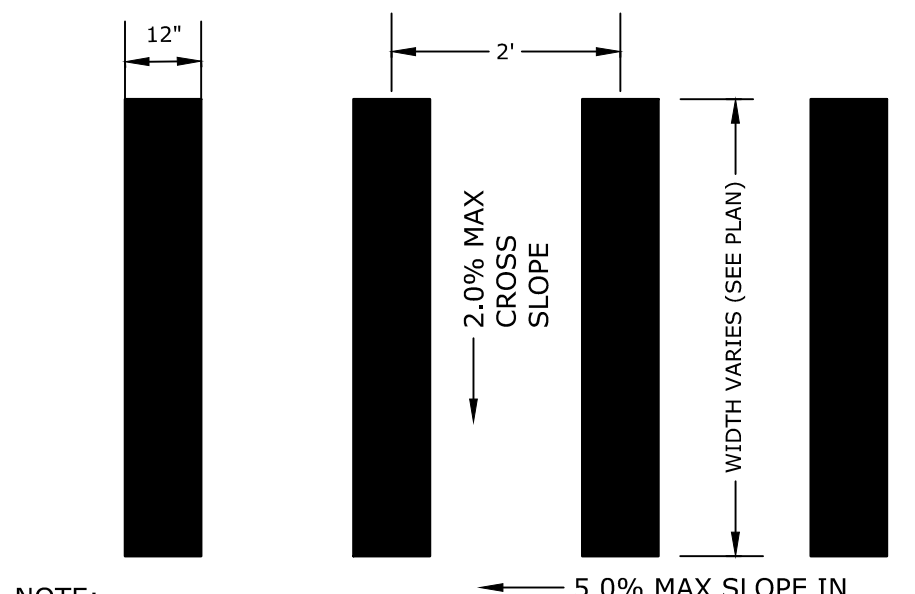

- NOTE:** STRIPING SHALL BE CONSTRUCTED USING WHITE THERMO PLASTIC, REFLECTORIZED PAVEMENT MARKING MATERIAL MEETING THE REQUIREMENTS OF ASTM D 4505

CROSSWALK STRIPING
NO SCALE

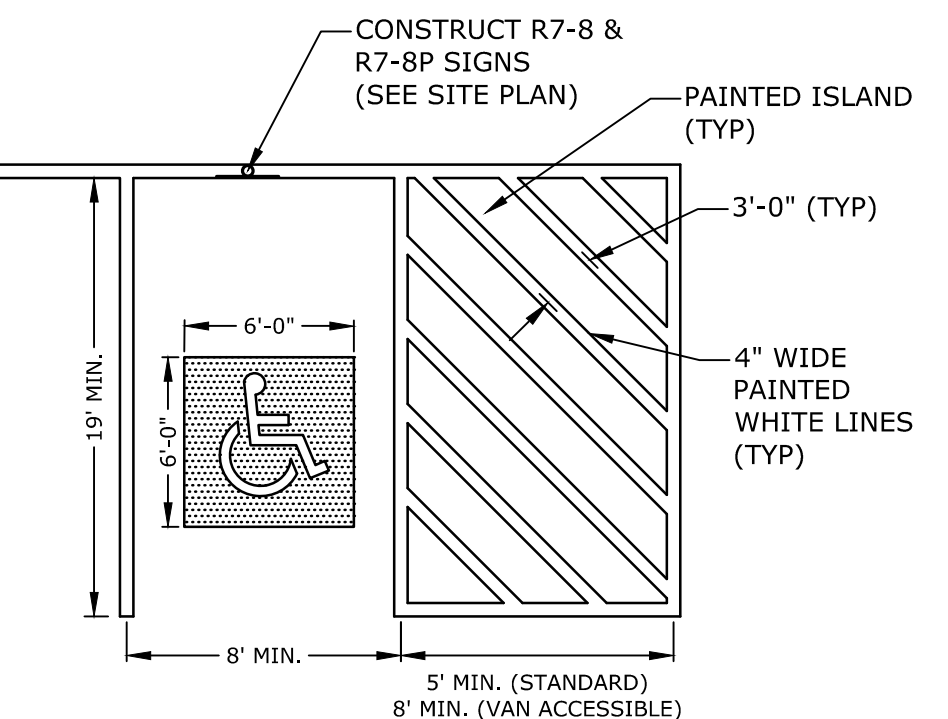

- NOTES:**
- ALL PAINT SHALL BE FAST DRYING TRAFFIC PAINT, MEETING THE REQUIREMENTS OF AASHTO M248-TYPE F. PAINT SHALL BE APPLIED AS SPECIFIED BY MANUFACTURER.
 - SYMBOLS & PARKING STALLS SHALL CONFORM TO THE REQUIREMENTS OF THE AMERICAN W/DISABILITIES ACT.

ACCESSIBLE PARKING STALL
NO SCALE

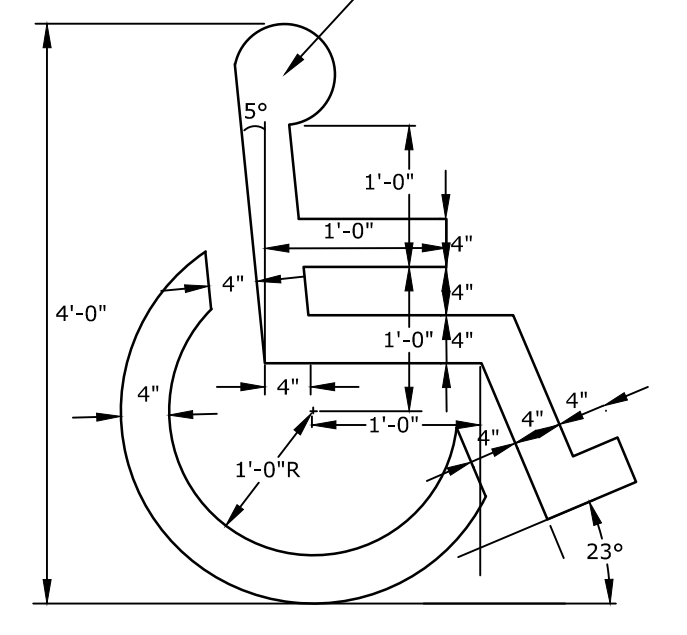

- NOTES:**
- SYMBOL SHALL BE CONSTRUCTED IN ALL ACCESSIBLE SPACES USING WHITE THERMOPLASTIC, REFLECTORIZED PAVEMENT MARKING MATERIAL MEETING THE REQUIREMENTS OF ASTM D 4505.
 - SYMBOL SHALL BE CONSTRUCTED TO THE LATEST ADA, STATE AND LOCAL REQUIREMENTS.

ACCESSIBLE SYMBOL
NO SCALE

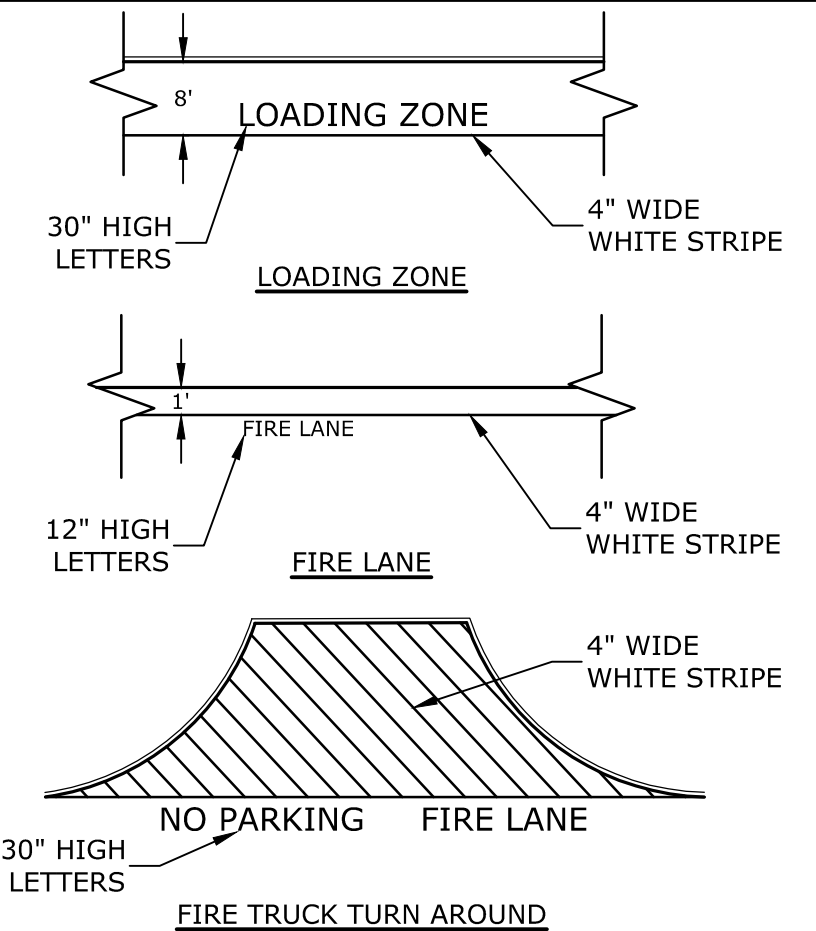

- NOTES:**
- ALL PAINT SHALL BE FAST DRYING TRAFFIC PAINT, MEETING THE REQUIREMENTS OF AASHTO M248-TYPE F. PAINT SHALL BE APPLIED AS SPECIFIED BY MANUFACTURER.

PAVEMENT MARKING DETAILS
NO SCALE

Proposed
Multi-Family
Development

Iron Horse
Properties, LLC

105 Bartlett Street
Portsmouth,
New Hampshire

MARK	DATE	DESCRIPTION
I	3/10/2021	PB Submission
H	1/20/2021	TAC Resubmission
G	11/18/2020	TAC Resubmission
F	10/28/2020	Wetland CUP Resubmission
E	5/20/2020	TAC Resubmission
D	4/29/2020	Wetland CUP Submission
C	4/20/2020	TAC Submission
B	2/6/2020	Design Review Submission
A	1/2/2020	ZBA Submission

PROJECT NO: C-0960-006
 DATE: April 20, 2020
 FILE: C-0960-006_C-DTLS.DWG
 DRAWN BY: NAH
 CHECKED: PMC
 APPROVED: BML

DETAILS SHEET

SCALE: AS SHOWN

C-504

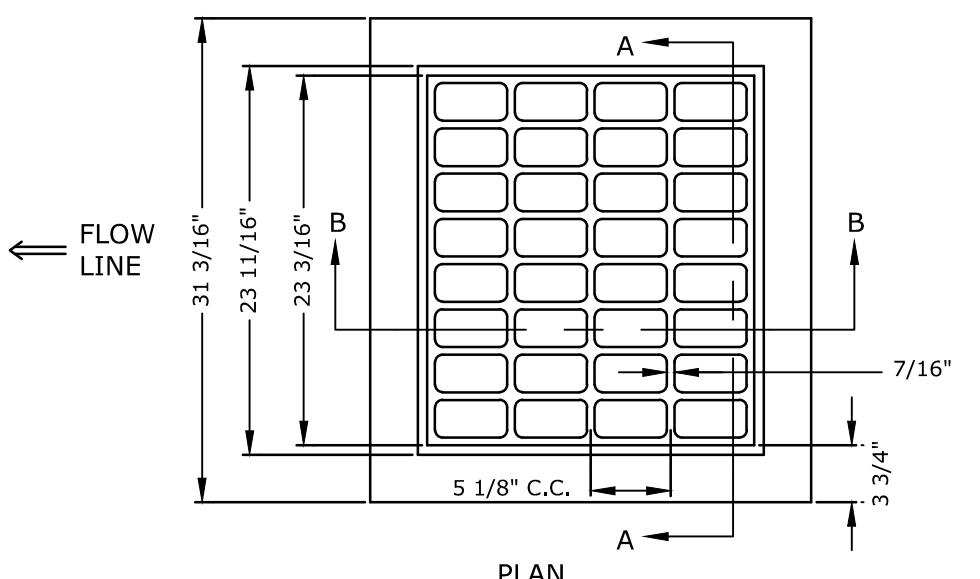

- NOTE:**
1. GRATE TO BE CAST IRON (NHDOT TYPE B)
 2. FRAME AND GRATE TO BE MANUFACTURED IN THE USA

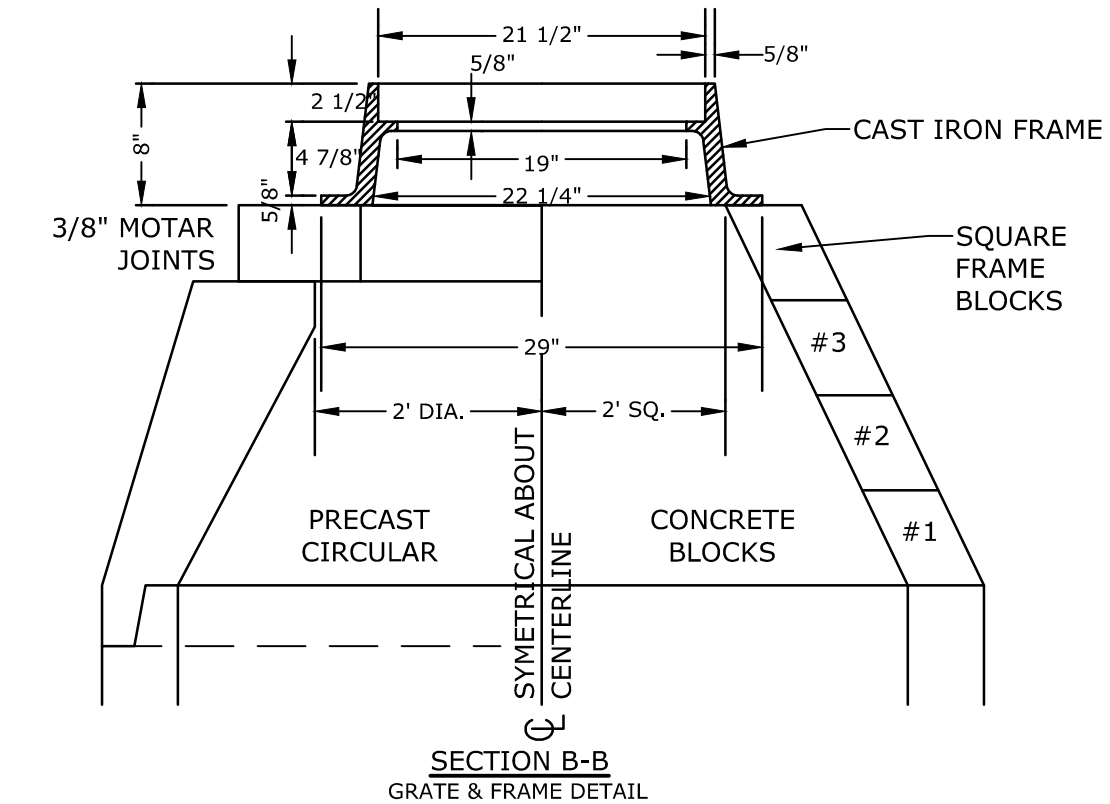
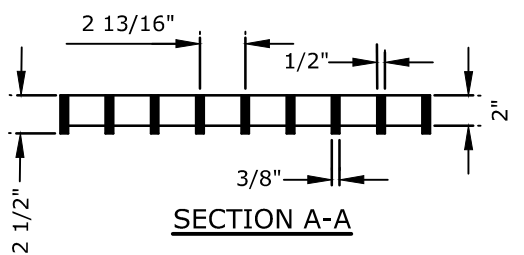

CATCH BASIN FRAME & GRATE
NO SCALE

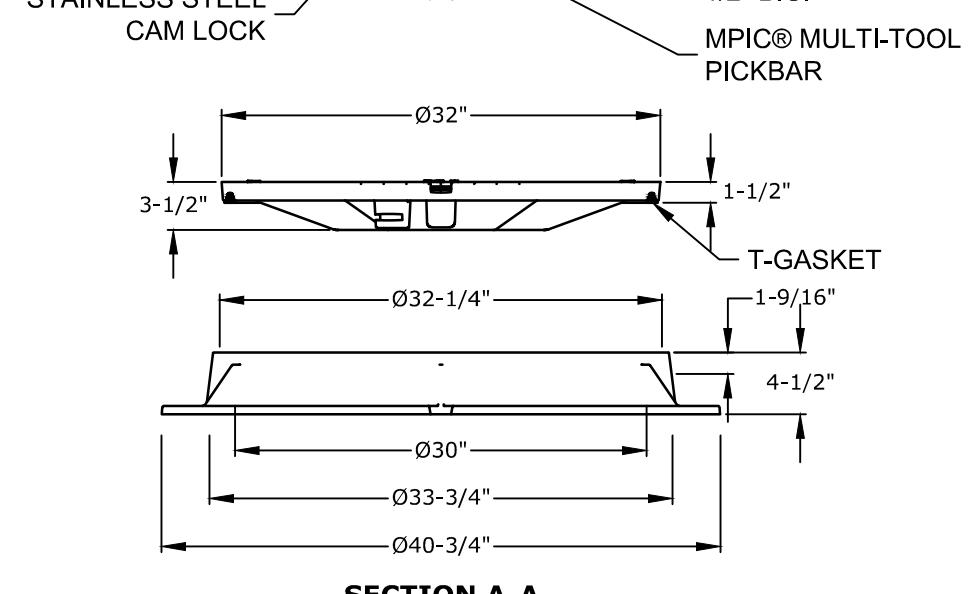
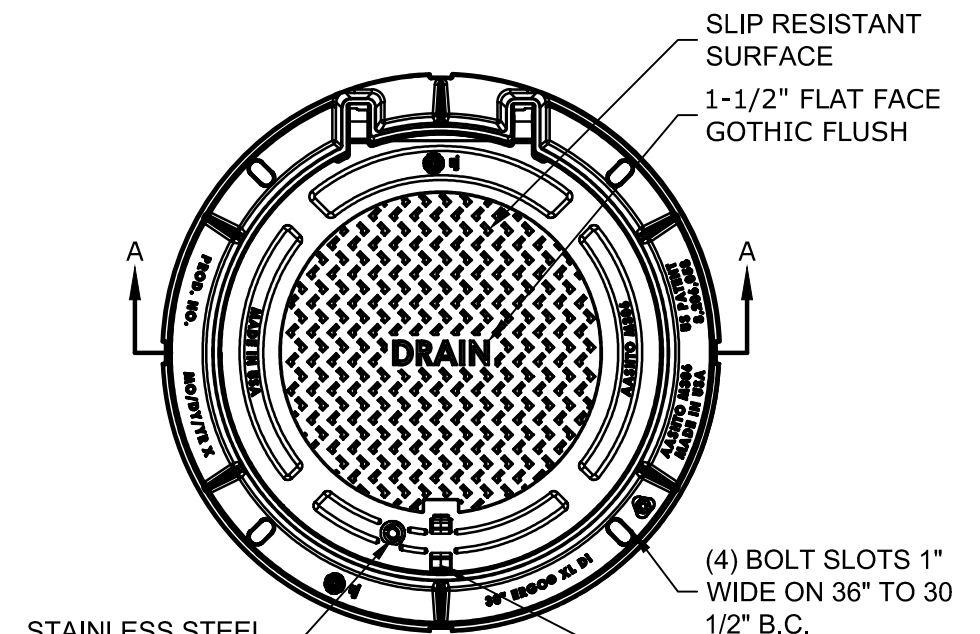

- NOTES:**
1. MANHOLE FRAME AND COVER SHALL BE 32" HINGED ERGO XL BY EJ CO.
 2. ALL DIMENSIONS ARE NOMINAL.
 3. FRAMES USING NARROWER DIMENSIONS FOR THICKNESS ARE ALLOWED PROVIDED:
 - A. THE FRAMES MEET OR EXCEED THE SPECIFIED LOAD RATING.
 - B. THE INTERIOR PERIMETER (SEAT AREA) DIMENSIONS OF THE FRAMES REMAIN THE SAME TO ALLOW CONTINUED USE OF EXISTING GRATES/COVERS AS THE EXISTING FRAMES ALLOW, WITHOUT SHIMS OR OTHER MODIFICATIONS OR ACCOMMODATIONS.
 - C. ALL OTHER PERTINENT REQUIREMENTS OF THE SPECIFICATIONS ARE MET.
 4. LABEL TYPE OF MANHOLE WITH 3" HIGH LETTERS IN THE CENTER OF THE COVER.

DRAIN MANHOLE FRAME & COVER
NO SCALE

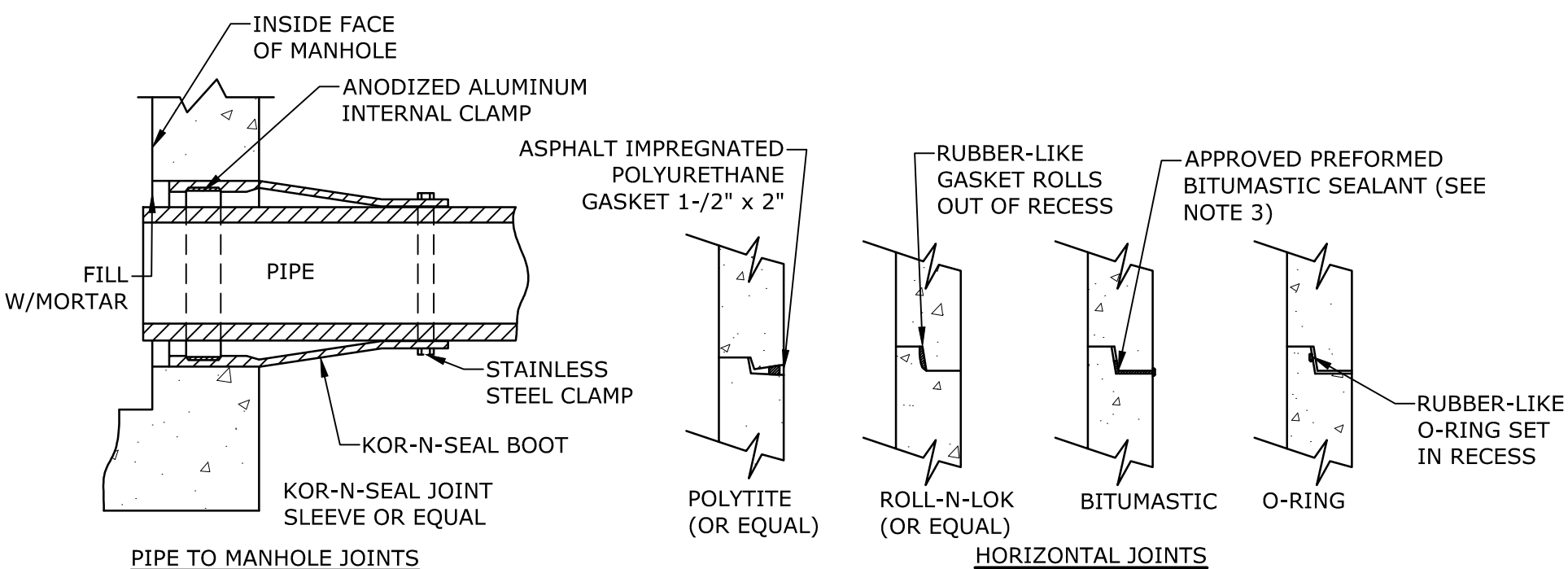

- NOTES:**
1. HORIZONTAL JOINTS BETWEEN THE SECTIONS OF PRECAST CONCRETE BARRELS SHALL BE PER CITY OF PORTSMOUTH DPW STANDARD AND SHALL BE SEALED FOR WATERTIGHTNESS USING A DOUBLE ROW ELASTOMERIC OR MASTIC-LIKE GASKET.
 2. PIPE TO MANHOLE JOINTS SHALL BE PER CITY OF PORTSMOUTH STANDARD.
 3. FOR BITUMASTIC TYPE JOINTS THE AMOUNT OF SEALANT SHALL BE SUFFICIENT TO FILL AT LEAST 75% OF THE JOINT CAVITY.
 4. ALL GASKETS, SEALANTS, MORTAR, ETC. SHALL BE INSTALLED IN ACCORDANCE WITH MANUFACTURERS' WRITTEN INSTRUCTIONS.

MANHOLE JOINTS
NO SCALE

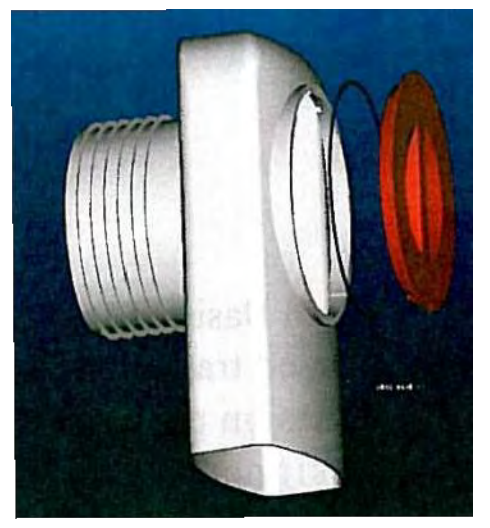

- NOTES:**
1. ALL CATCH BASIN OUTLETS TO HAVE "ELIMINATOR" OIL AND FLOATING DEBRIS TRAP MANUFACTURED BY KLEANSTREAM (NO EQUAL)
 2. INSTALL DEBRIS TRAP TIGHT TO INSIDE OF STRUCTURE.
 3. 1/4" HOLE SHALL BE DRILLED IN TOP OF DEBRIS TRAP

"ELIMINATOR" OIL FLOATING DEBRIS TRAP
NO SCALE

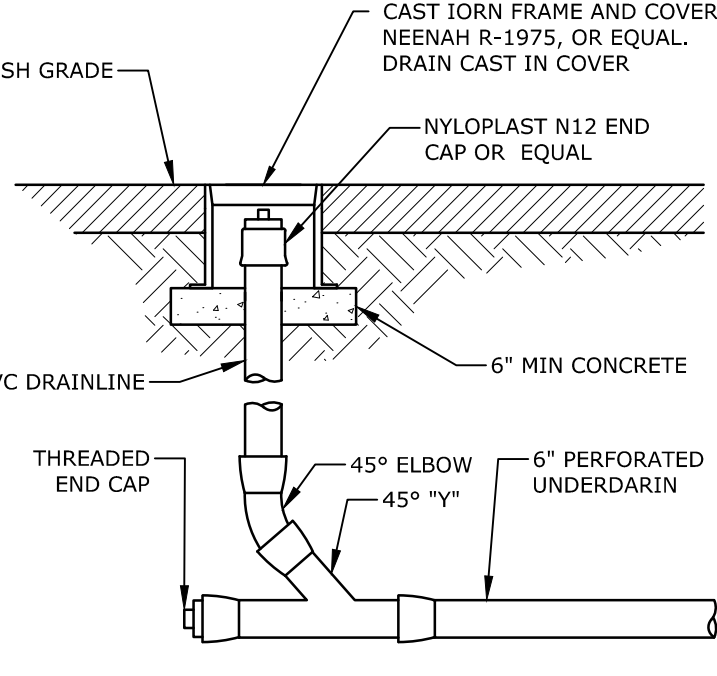

DRAIN CLEAN-OUT
NO SCALE

NOMINAL PIPE SIZE I.D.*	OVERALL LENGTH**		NUMBER OF CLAMPS	CUFF DEPTH		BACK PRESSURE RATING	
	Inches	Millimeters		Inches	Millimeters	Feet	Meters
12	300	23	584	1	2	51	40
18	450	31	787	1	4	102	20
24	600	47.5	1207	2	6	203	20

Mounting Styles and Configurations

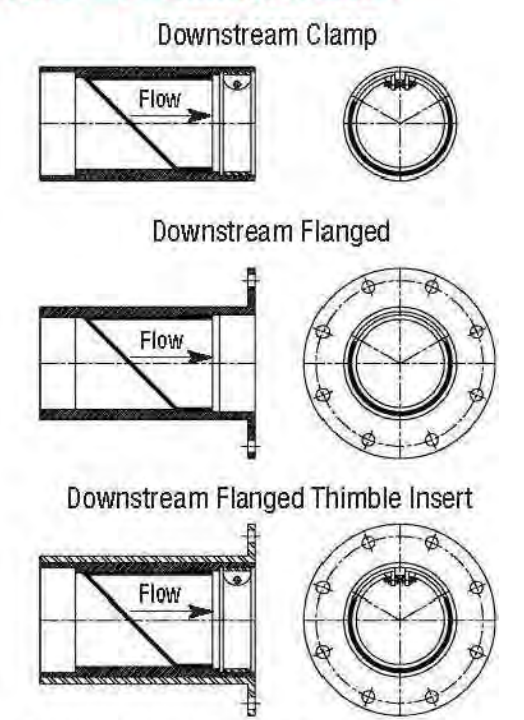

Flange shape and bolt pattern can be customized. Flangeless thimble inserts are available.

TYPICAL BACK FLOW PREVENTER
NO SCALE

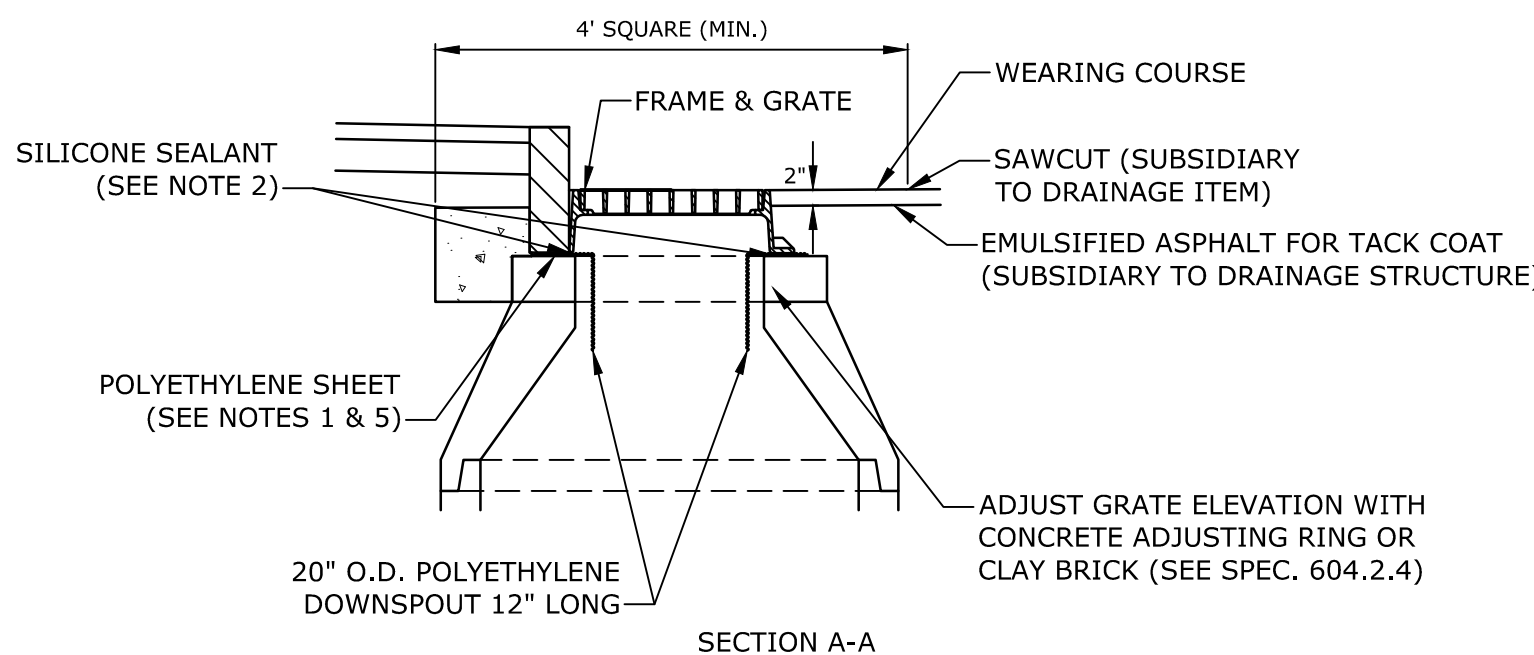
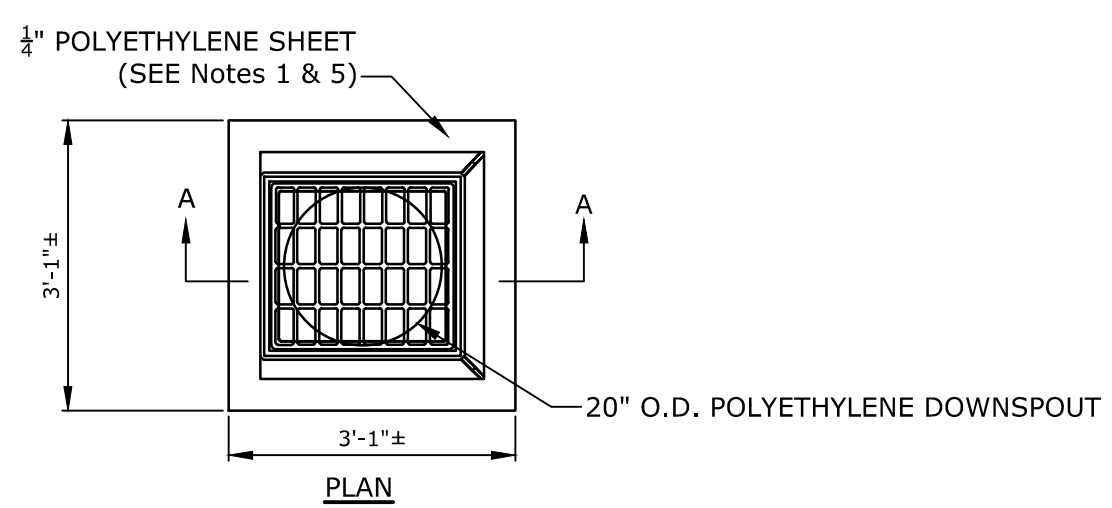
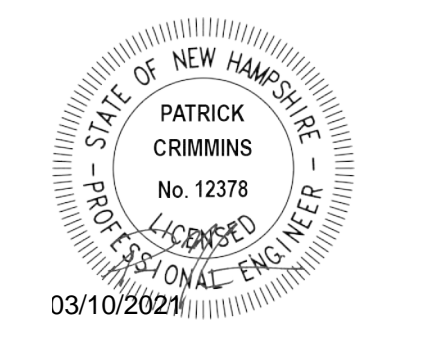

POLYETHYLENE LINER
NO SCALE

- NOTES:**
1. POLYETHYLENE LINER (ITEM 604.0007) SHALL BE FABRICATED AT THE SHOP. DOWNSPOUT SHALL BE EXTRUSION FILLET WELDED TO THE POLYETHYLENE SHEET.
 2. PLACE A CONTINUOUS BEAD OF AN APPROVED SILICONE SEALANT (SUBSIDIARY TO ITEM 604.0007) BETWEEN FRAME AND POLYETHYLENE SHEET.
 3. PLACE CLASS AA CONCRETE TO 2" BELOW THE TOP OF THE GRATE ELEVATION (SUBSIDIARY TO DRAINAGE STRUCTURE).
 4. USE ON DRAINAGE STRUCTURES 4" MIN. DIAMETER ONLY.
 5. TRIM POLYETHYLENE SHEET A MAXIMUM OF 4" OUTSIDE THE FLANGE ON THE FRAME FOR THE CATCH BASIN BEFORE PLACING CONCRETE (EXCEPT AS SHOWN WHEN USED WITH 3-FLANGE FRAME AND CURB).
 6. THE CENTER OF THE GRATE & FRAME MAY BE SHIFTED A MAXIMUM OF 6" FROM THE CENTER OF THE DOWNSPOUT IN ANY DIRECTION.
 7. PLACED ONLY IN DRAINAGE STRUCTURES IN PAVEMENT.
 8. SEE NHDOT DR-04, "DI-DB, UNDERDRAIN FLUSHING BASIN AND POLYETHYLENE LINER DETAILS", FOR ADDITIONAL INFORMATION.
 9. CATCHBASINS WITHIN CITY RIGHT OF WAY SHALL HAVE A POLYETHYLENE LINER

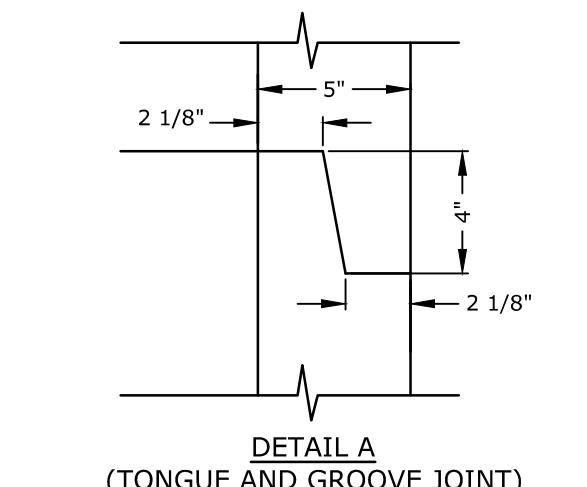
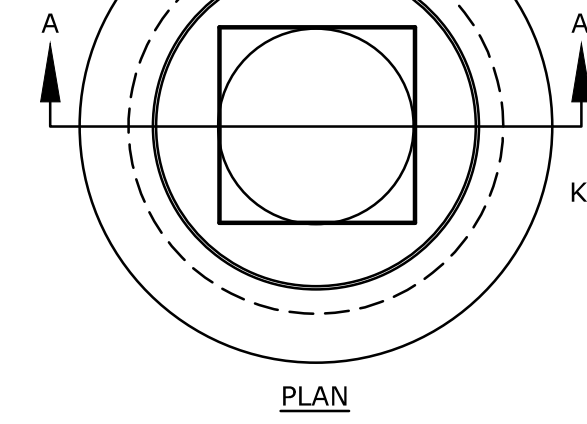
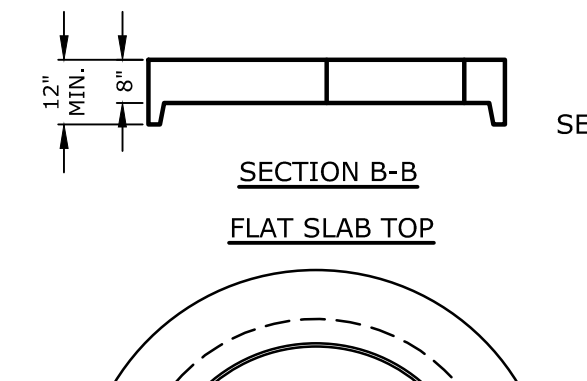

4' DIAMETER CATCHBASIN
NO SCALE

- NOTES:**
1. ALL SECTIONS SHALL BE CONCRETE CLASS AA(4000 PSI).
 2. CIRCUMFERENTIAL REINFORCEMENT SHALL BE 0.12 SQ. IN. PER LINEAR FT. IN ALL SECTIONS AND SHALL BE PLACED IN THE CENTER THIRD OF THE WALL.
 3. THE TONGUE AND GROOVE OF THE JOINT SHALL CONTAIN ONE LINE OF CIRCUMFERENTIAL REINFORCEMENT EQUAL TO 0.12 SQ. IN. PER LINEAR FT.
 4. RISERS OF 1', 2', 3' & 4' CAN BE USED TO REACH DESIRED DEPTH.
 5. THE STRUCTURES SHALL BE DESIGNED FOR H2O LOADING.
 6. FITTING FRAME TO GRADE MAY BE DONE WITH PREFABRICATED ADJUSTMENT RINGS OR CLAY BRICKS (2 COURSES MAX.).
 7. CONE SECTIONS MAY BE EITHER CONCENTRIC OR ECCENTRIC, OR FLAT SLAB TOPS MAY BE USED WHERE PIPE WOULD OTHERWISE ENTER INTO THE CONE SECTION OF THE STRUCTURE AND WHERE PERMITTED.
 8. PIPE ELEVATIONS SHOWN ON PLANS SHALL BE FIELD VERIFIED PRIOR TO PRECASTING.
 9. OUTSIDE EDGES OF PIPES SHALL PROJECT NO MORE THAN 3" BEYOND INSIDE WALL OF STRUCTURE.
 10. PRECAST SECTIONS SHALL HAVE A TONGUE AND GROOVE JOINT 4" HIGH AT AN 11° ANGLE CENTERED IN THE WIDTH OF THE WALL AND SHALL BE ASSEMBLED USING AN APPROVED FLEXIBLE SEALANT IN JOINTS.
 11. THE TONGUE AND GROOVE JOINT SHALL BE SEALED WITH ONE STRIP OF BUTYL RUBBER SEALANT.
 12. "ELIMINATOR" OIL/WATER SEPARATOR SHALL BE INSTALLED TIGHT TO INSIDE OF CATCHBASIN.

NHDOT ITEM No. 304.4 (CRUSHED STONE - FINE)	
SIEVE SIZE	% PASSING
2"	100
1-1/2"	85-100
3/4"	45-75
#4	10-45
#200	0-5

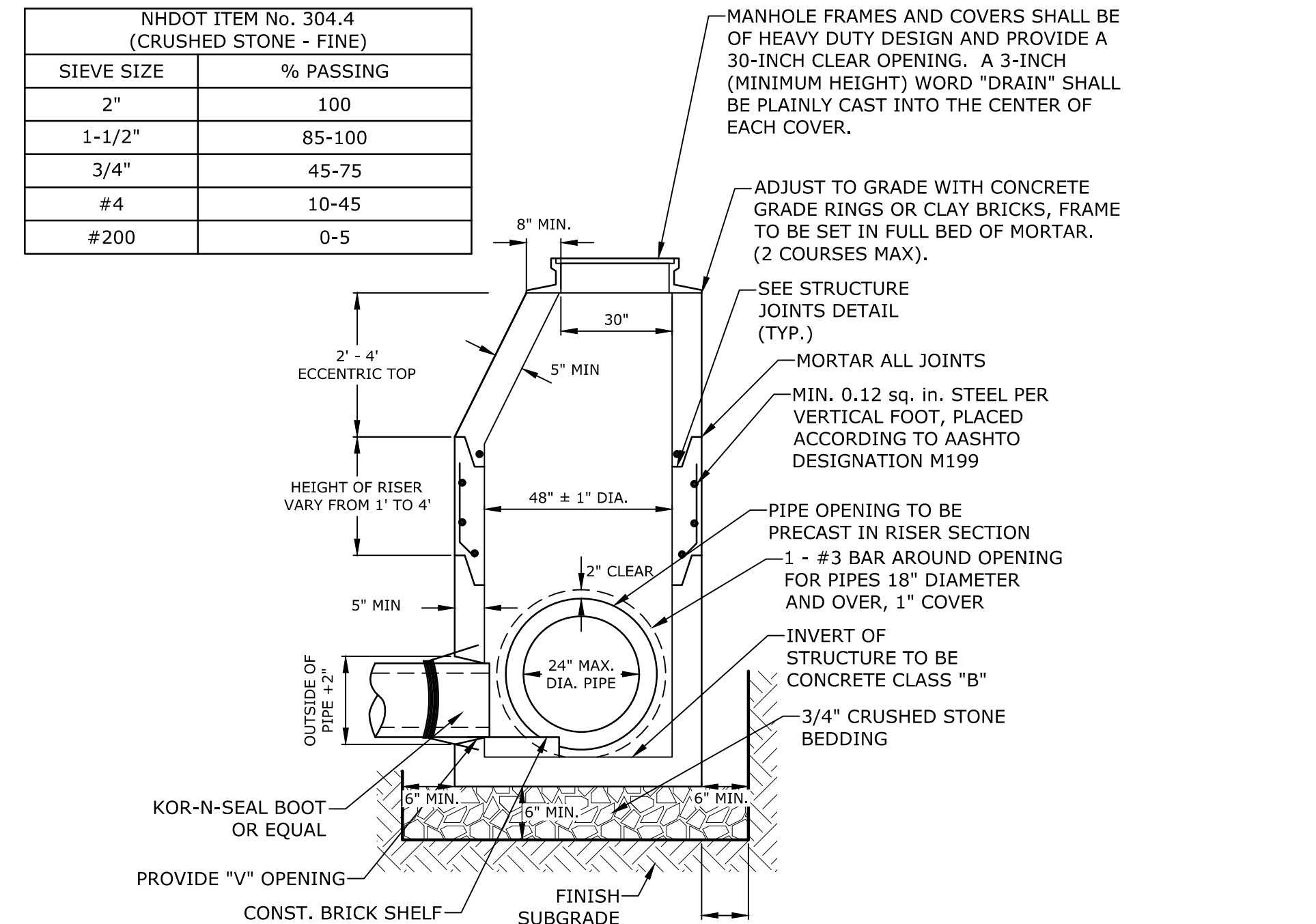

- NOTES:**
1. ALL SECTIONS SHALL BE 4,000 PSI CONCRETE.
 2. CIRCUMFERENTIAL REINFORCEMENT SHALL BE 0.12 SQUARE INCHES PER LINEAR FOOT IN ALL SECTIONS AND SHALL BE PLACED IN THE CENTER THIRD OF THE WALL.
 3. THE TONGUE AND THE GROOVE OF THE JOINT SHALL CONTAIN ONE LINE OF CIRCUMFERENTIAL REINFORCEMENT EQUAL TO 0.12 SQUARE INCHES PER LINEAR FOOT.
 4. THE STRUCTURES SHALL BE DESIGNED FOR H2O LOADING.
 5. CONSTRUCT CRUSHED STONE BEDDING AND BACKFILL UNDER (6" MINIMUM THICKNESS)
 6. THE TONGUE AND GROOVE JOINT SHALL BE SEALED WITH ONE STRIP OF BUTYL RUBBER SEALANT.
 7. PIPE ELEVATIONS SHOWN ON PLANS SHALL BE FIELD VERIFIED PRIOR TO PRECASTING.
 8. OUTSIDE EDGES OF PIPES SHALL PROJECT NO MORE THAN 3" BEYOND INSIDE WALL OF STRUCTURE.
 9. PRECAST SECTIONS SHALL HAVE A TONGUE AND GROOVE JOINT 4" HIGH AT AN 11° ANGLE CENTERED IN THE WIDTH OF THE WALL AND SHALL BE ASSEMBLED USING AN APPROVED FLEXIBLE SEALANT IN JOINTS.
 10. ALL STRUCTURES WITH MULTIPLE PIPES SHALL HAVE A MINIMUM OF 12" OF INSIDE SURFACE BETWEEN HOLES, NO MORE THAN 75% OF A HORIZONTAL CROSS SECTION SHALL BE HOLES, AND THERE SHALL BE NO HOLES CLOSER THAN 3" TO JOINTS.

4' DIAMETER DRAIN MANHOLE
NO SCALE

Proposed Multi-Family Development

Iron Horse Properties, LLC

**105 Bartlett Street
Portsmouth,
New Hampshire**

MARK	DATE	DESCRIPTION
I	3/10/2021	PB Submission
H	1/20/2021	TAC Resubmission
G	11/18/2020	TAC Resubmission
F	10/28/2020	Wetland CUP Resubmission
E	5/20/2020	TAC Resubmission
D	4/29/2020	Wetland CUP Submission
C	4/20/2020	TAC Submission
B	2/6/2020	Design Review Submission
A	1/2/2020	ZBA Submission

PROJECT NO:	C-0960-008
DATE:	April 20, 2020
FILE:	C-0960-008_C-DTLS.DWG
DRAWN BY:	NAH
CHECKED:	PMC
APPROVED:	BML

DETAILS SHEET

SCALE: AS SHOWN

C-505

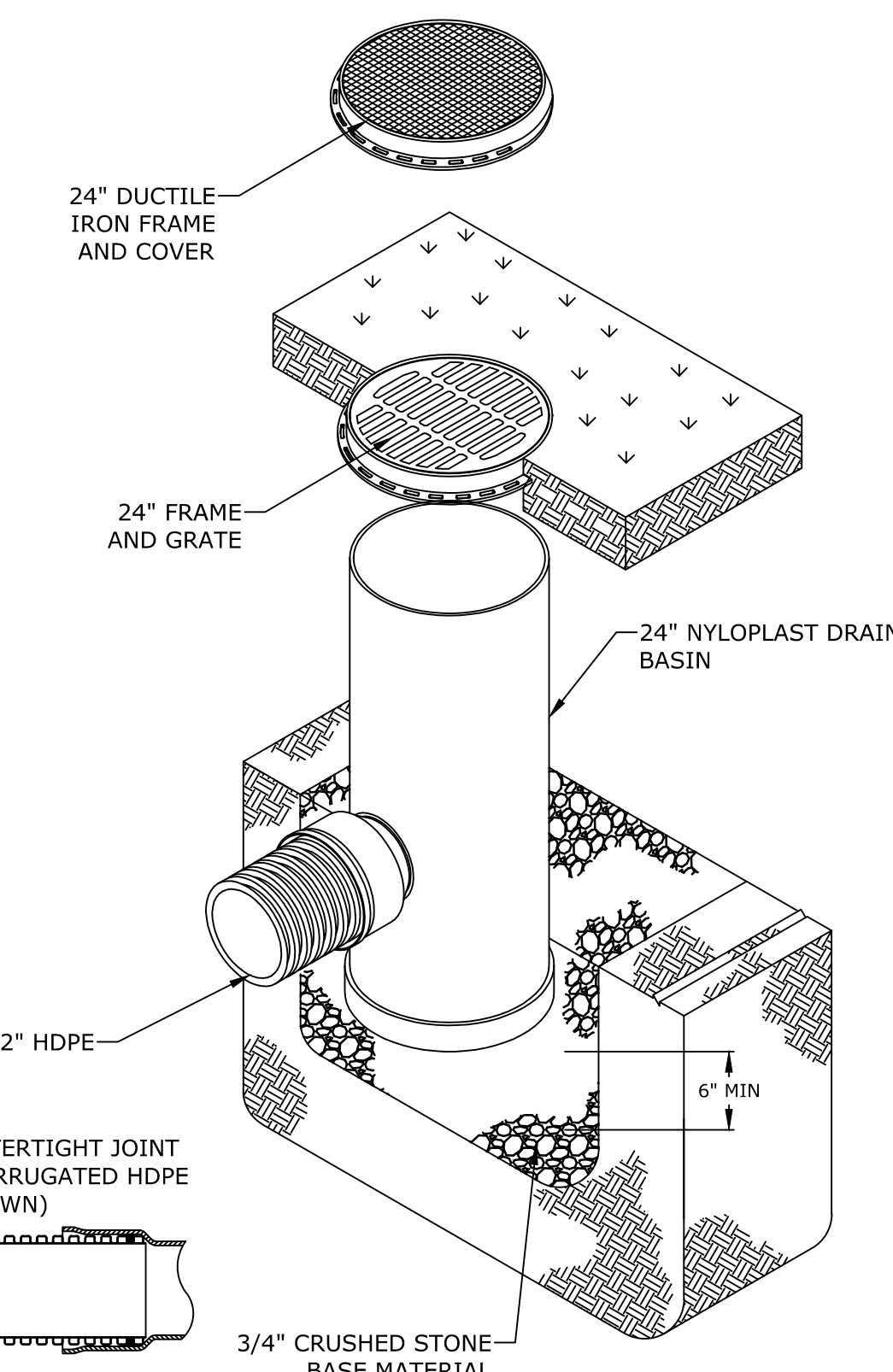

- NOTES:**
1. GRATES/SOLID COVER SHALL BE DUCTILE IRON PER ASTM A536 GRADE 70-50-05.
 2. FRAMES SHALL BE DUCTILE IRON PER ASTM A536 GRADE 70-50-05
 3. SEE GRADING, DRAINAGE, AND EROSION CONTROL PLAN FOR LOCATIONS.

YARD DRAIN
NO SCALE

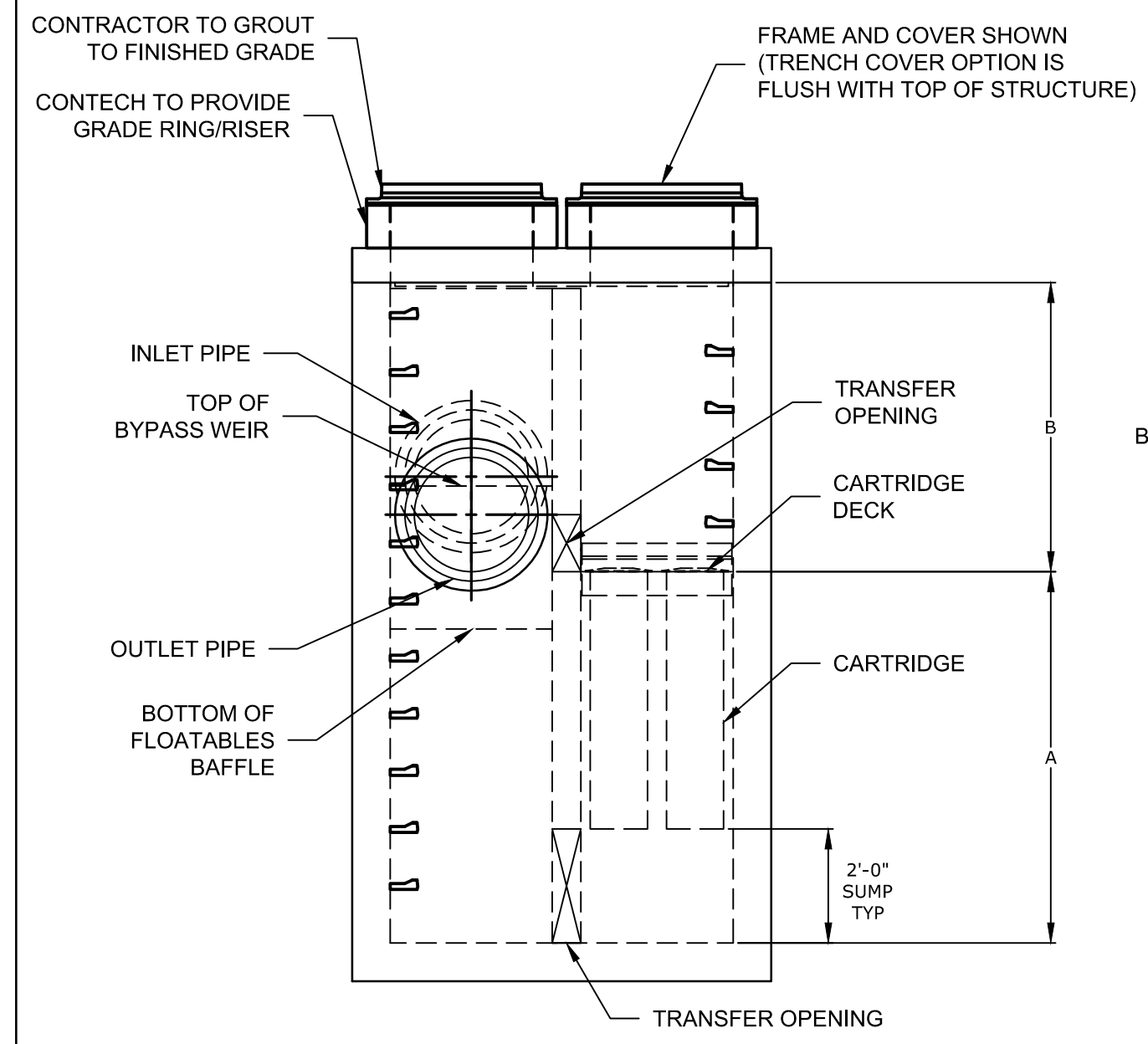
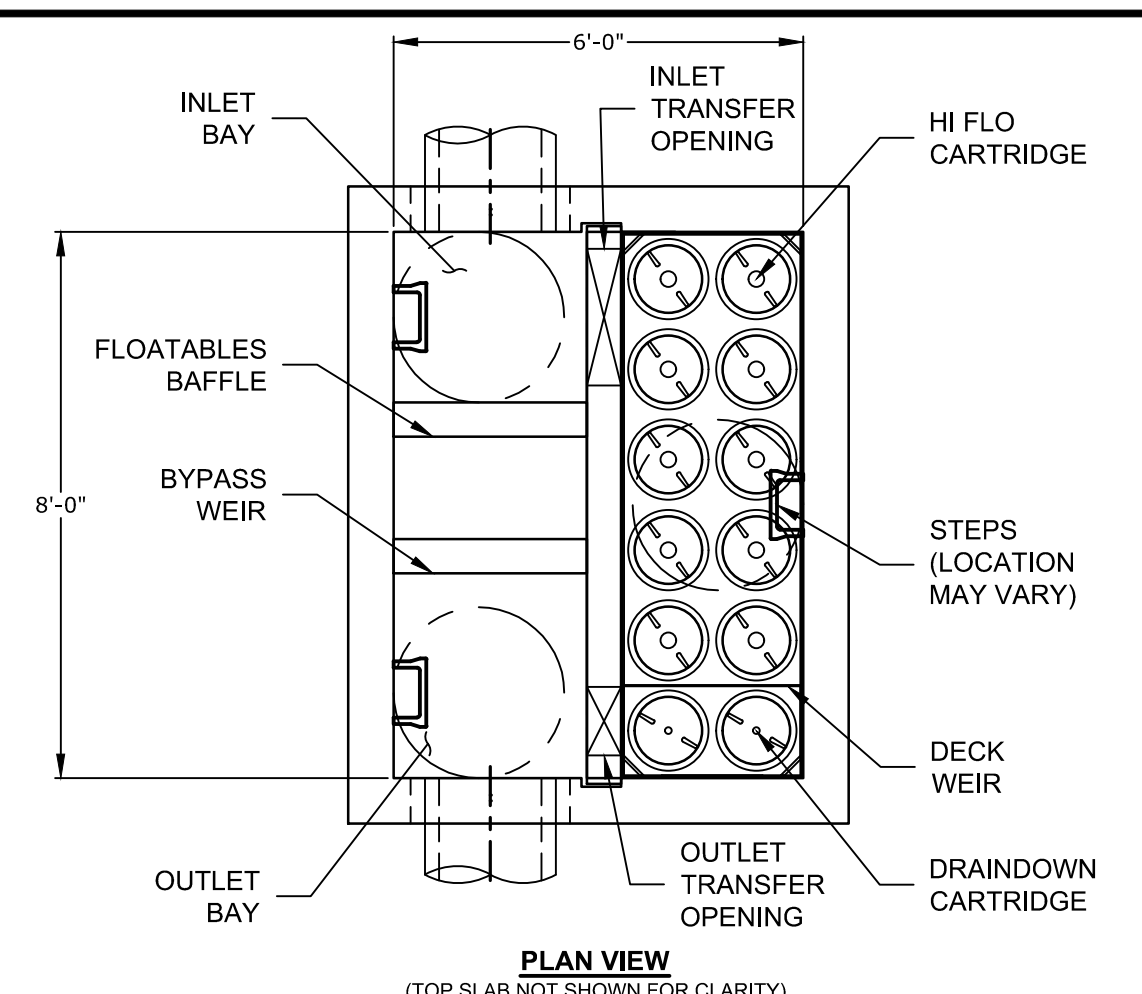

ELEVATION VIEW
JELLYFISH JFPD0806

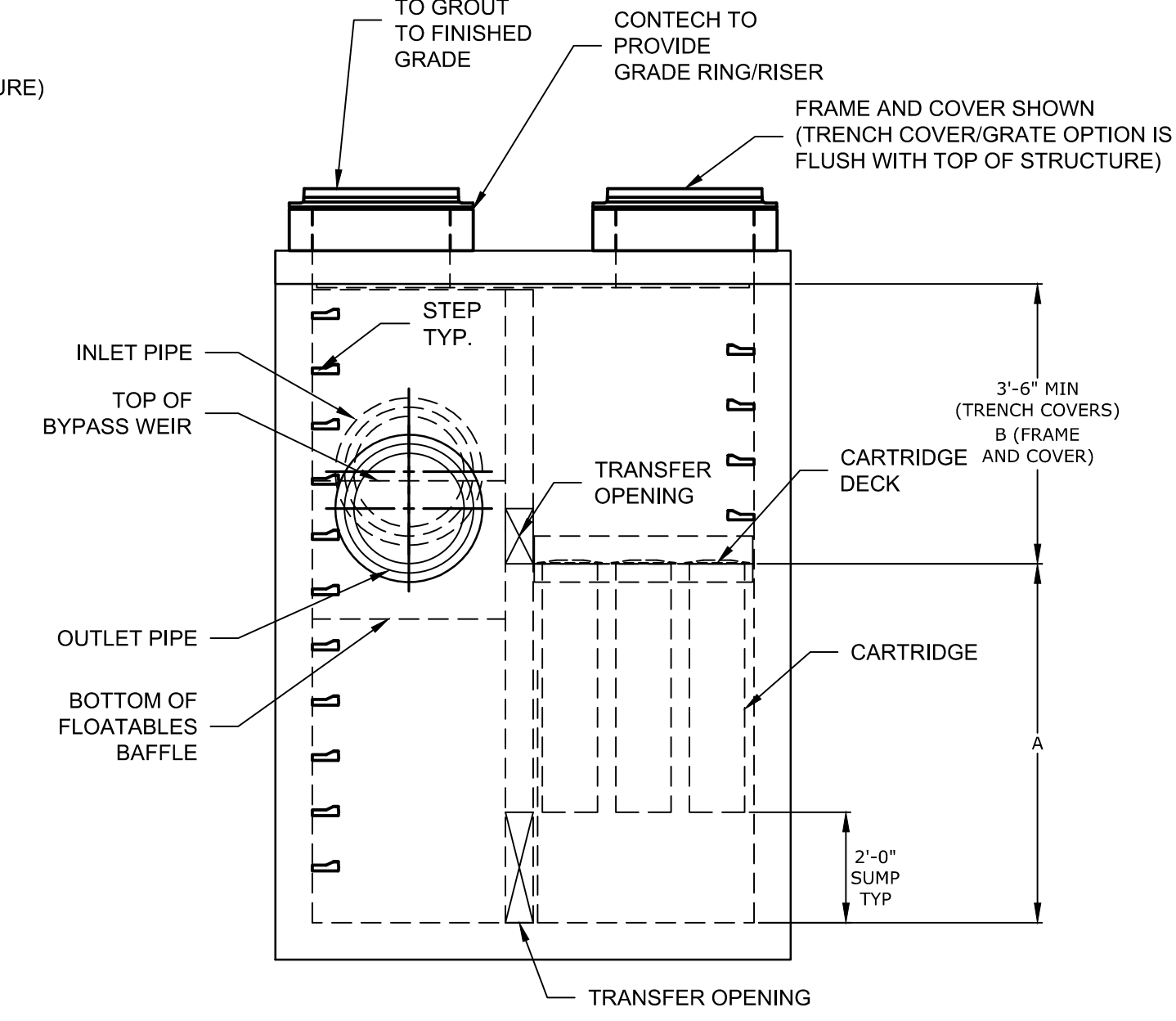
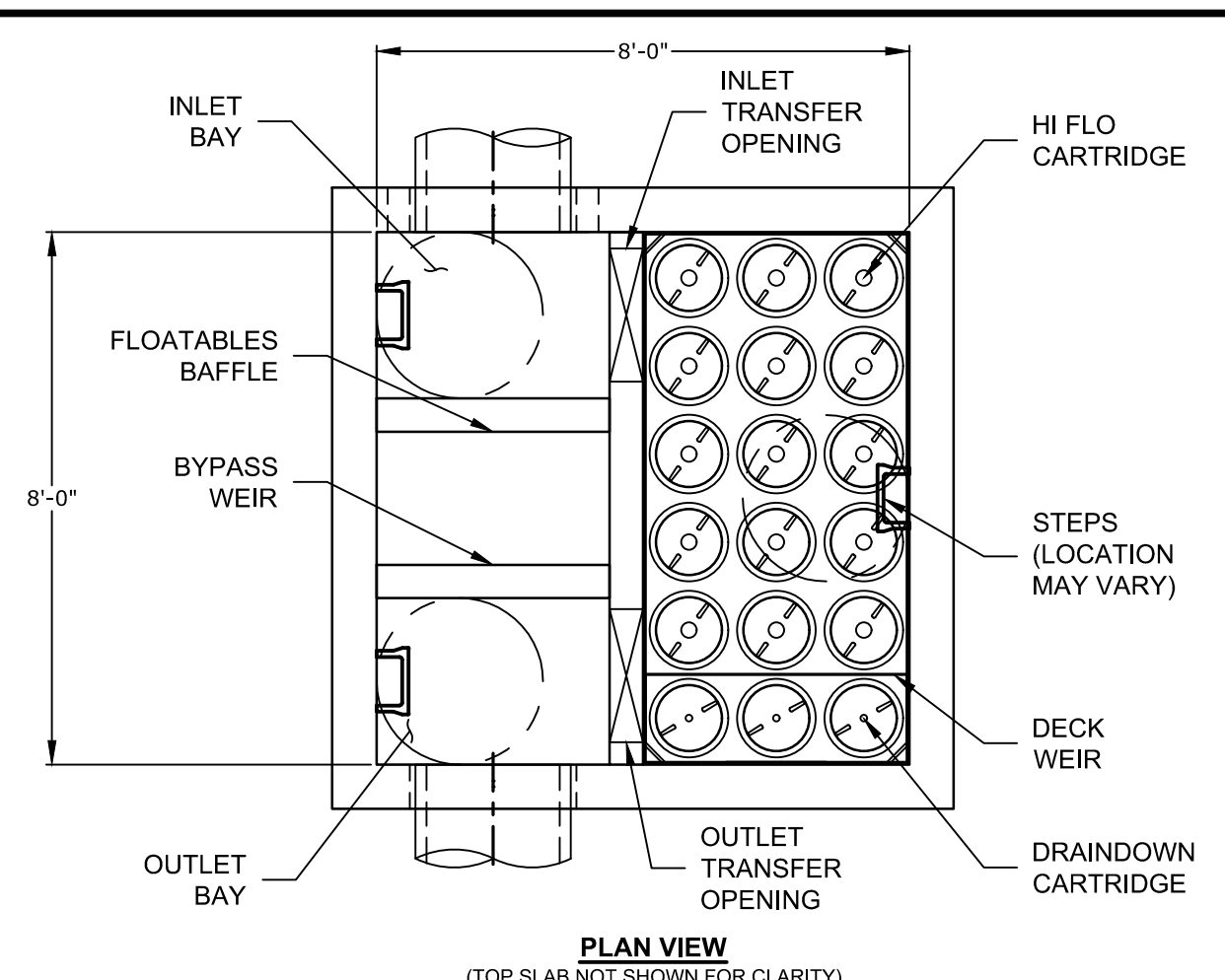

ELEVATION VIEW
JELLYFISH JFPD0808
CONTECH JELLYFISH STORMWATER FILTER
NO SCALE

JELLYFISH JFPD0808 - DESIGN NOTES

JELLYFISH TREATMENT CAPACITY IS A FUNCTION OF THE CARTRIDGE LENGTH AND THE NUMBER OF CARTRIDGES. THE STANDARD PEAK DIVERSION STYLE WITH PRECAST TOP SLAB IS SHOWN. ALTERNATE OFFLINE VAULT AND/OR SHALLOW ORIENTATIONS ARE AVAILABLE. PEAK CONVEYANCE CAPACITY TO BE DETERMINED BY ENGINEER OF RECORD

CARTRIDGE SELECTION	54"	40"	27"	15"
CARTRIDGE LENGTH	54"	40"	27"	15"
OUTLET INVERT TO STRUCTURE INVERT (A)	6'-6"	5'-4"	4'-3"	3'-3"
FLOW RATE HI-FLO / DRAINDOWN (CFS) (PER CART)	0.178 / 0.089	0.133 / 0.067	0.089 / 0.045	0.049 / 0.025
MAX. TREATMENT (CFS)	2.94	2.21	1.47	0.81
DECK TO INSIDE TOP (MIN) (B)	5.00	4.00	4.00	4.00

JELLYFISH JFPD0806 - DESIGN NOTES

JELLYFISH TREATMENT CAPACITY IS A FUNCTION OF THE CARTRIDGE LENGTH AND THE NUMBER OF CARTRIDGES. THE STANDARD PEAK DIVERSION STYLE WITH PRECAST TOP SLAB IS SHOWN. ALTERNATE OFFLINE VAULT AND/OR SHALLOW ORIENTATIONS ARE AVAILABLE. PEAK CONVEYANCE CAPACITY TO BE DETERMINED BY ENGINEER OF RECORD

CARTRIDGE SELECTION	54"	40"	27"	15"
CARTRIDGE LENGTH	54"	40"	27"	15"
OUTLET INVERT TO STRUCTURE INVERT (A)	6'-6"	5'-4"	4'-3"	3'-3"
FLOW RATE HI-FLO / DRAINDOWN (CFS) (PER CART)	0.178 / 0.089	0.133 / 0.067	0.089 / 0.045	0.049 / 0.025
MAX. TREATMENT (CFS)	1.96	1.47	0.98	0.54
DECK TO INSIDE TOP (MIN) (B)	5.00	4.00	4.00	4.00

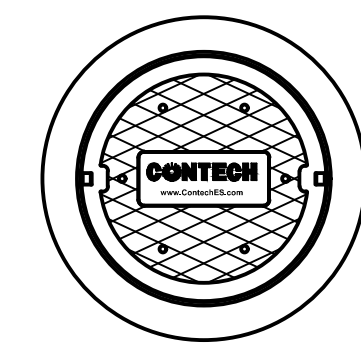

SITE SPECIFIC DATA REQUIREMENTS

STRUCTURE ID	JF-1	JF-2	JF-3	JF-4
MODEL SIZE	JFPD0808	JFPD0806	JFPD0806	JFPD0806
WATER QUALITY FLOW RATE (cfs)	2.85	0.63	0.89	1.48
PEAK FLOW RATE (cfs)	26.54	5.13	7.62	8.19
RETURN PERIOD OF PEAK FLOW (yrs)	25	25	25	25
# OF CARTRIDGES REQUIRED (HF / DD)	15/3	5/1	5/2	7/2
CARTRIDGE SIZE	54"	40"	54"	54"

- GENERAL NOTES:**
1. CONTECH TO PROVIDE ALL MATERIALS UNLESS NOTED OTHERWISE.
 2. FOR SITE SPECIFIC DRAWINGS WITH DETAILED STRUCTURE DIMENSIONS AND WEIGHT, PLEASE CONTACT YOUR CONTECH ENGINEERED SOLUTIONS REPRESENTATIVE. www.contechES.com
 3. JELLYFISH WATER QUALITY STRUCTURE SHALL BE IN ACCORDANCE WITH ALL DESIGN DATA AND INFORMATION CONTAINED IN THIS DRAWING. CONTRACTOR TO CONFIRM STRUCTURE MEETS REQUIREMENTS OF PROJECT.
 4. STRUCTURE SHALL MEET AASHTO HS-20 OR PER APPROVING JURISDICTION REQUIREMENTS, WHICHEVER IS MORE STRINGENT, ASSUMING EARTH COVER OF 0' - 3' AND GROUNDWATER ELEVATION AT OR BELOW THE OUTLET PIPE INVERT ELEVATION. ENGINEER OF RECORD TO CONFIRM ACTUAL GROUNDWATER ELEVATION. CASTINGS SHALL MEET AASHTO M88 LOAD RATING AND BE CAST WITH THE CONTECH LOGO.
 5. STRUCTURE SHALL BE PRECAST CONCRETE CONFORMING TO ASTM C-478 AND AASHTO LOAD FACTOR DESIGN METHOD.
 6. OUTLET PIPE INVERT IS EQUAL TO THE CARTRIDGE DECK ELEVATION.
 7. THE OUTLET PIPE DIAMETER FOR NEW INSTALLATIONS IS TO BE ONE PIPE SIZE LARGER THAN THE INLET PIPE AT EQUAL OR GREATER SLOPE.
 8. NO PRODUCT SUBSTITUTIONS SHALL BE ACCEPTED UNLESS SUBMITTED 10 DAYS PRIOR TO PROJECT BID DATE, OR AS DIRECTED BY THE ENGINEER OF RECORD.

- INSTALLATION NOTES**
- A. ANY SUB-BASE BACKFILL DEPTH, AND/OR ANTI-FLOTATION PROVISIONS ARE SITE-SPECIFIC DESIGN CONSIDERATIONS AND SHALL BE SPECIFIED BY ENGINEER OF RECORD.
 - B. CONTRACTOR TO PROVIDE EQUIPMENT WITH SUFFICIENT LIFTING AND REACH CAPACITY TO LIFT AND SET THE STRUCTURE (LIFTING CLUTCHES PROVIDED).
 - C. CONTRACTOR WILL INSTALL AND LEVEL THE STRUCTURE, SEALING THE JOINTS, LINE ENTRY AND EXIT POINTS (NON-SHRINK GROUT WITH APPROVED WATERSTOP OR FLEXIBLE BOOT).
 - D. CONTRACTOR TO TAKE APPROPRIATE MEASURES TO PROTECT CARTRIDGES FROM CONSTRUCTION-RELATED EROSION RUNOFF.
 - E. CARTRIDGE INSTALLATION BY CONTECH SHALL OCCUR ONLY AFTER SITE HAS BEEN STABILIZED AND THE JELLYFISH UNIT IS CLEAN AND FREE OF DEBRIS. CONTACT CONTECH TO COORDINATE CARTRIDGE INSTALLATION WITH SITE STABILIZATION AT (866) 740-3318.

Jellyfish Filter

THIS PRODUCT MAY BE PHOTOCOPIED BY ONE OR MORE OF THE FOLLOWING: PROJECT NO. 10307 FOR 10/1/19 & U.S. 12/19/19. OTHER INTERNATIONAL PATENTS PENDING.

CONTECH ENGINEERED SOLUTIONS LLC

9025 Centre Pointe Dr., Suite 400, West Chester, OH 45399
800-338-1122 513-645-7000 513-645-7993 FAX

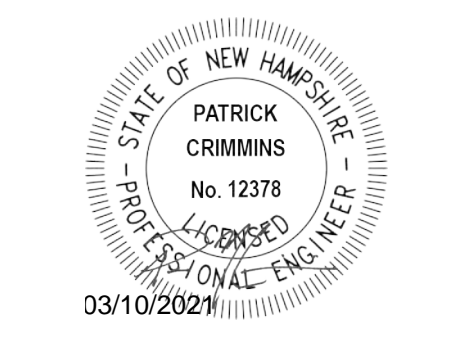
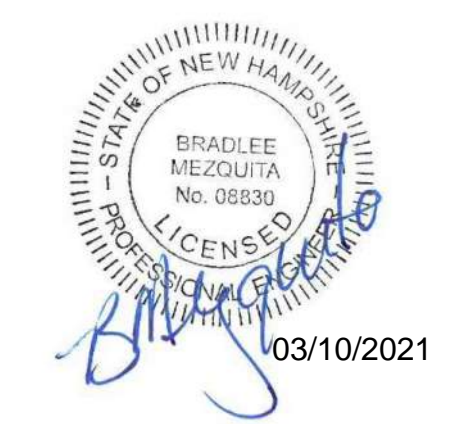

Proposed Multi-Family Development

Iron Horse Properties, LLC

105 Bartlett Street
Portsmouth,
New Hampshire

MARK	DATE	DESCRIPTION
I	3/10/2021	PB Submission
H	1/20/2021	TAC Resubmission
G	11/18/2020	TAC Resubmission
F	10/28/2020	Wetland CUP Resubmission
E	5/20/2020	TAC Resubmission
D	4/29/2020	Wetland CUP Submission
C	4/20/2020	TAC Submission
B	2/6/2020	Design Review Submission
A	1/2/2020	ZBA Submission

PROJECT NO: C-0960-008
DATE: April 20, 2020
FILE: C-0960-008_C-DTLS.DWG
DRAWN BY: NAH
CHECKED: PMC
APPROVED: BML

DETAILS SHEET

SCALE: AS SHOWN

C-506

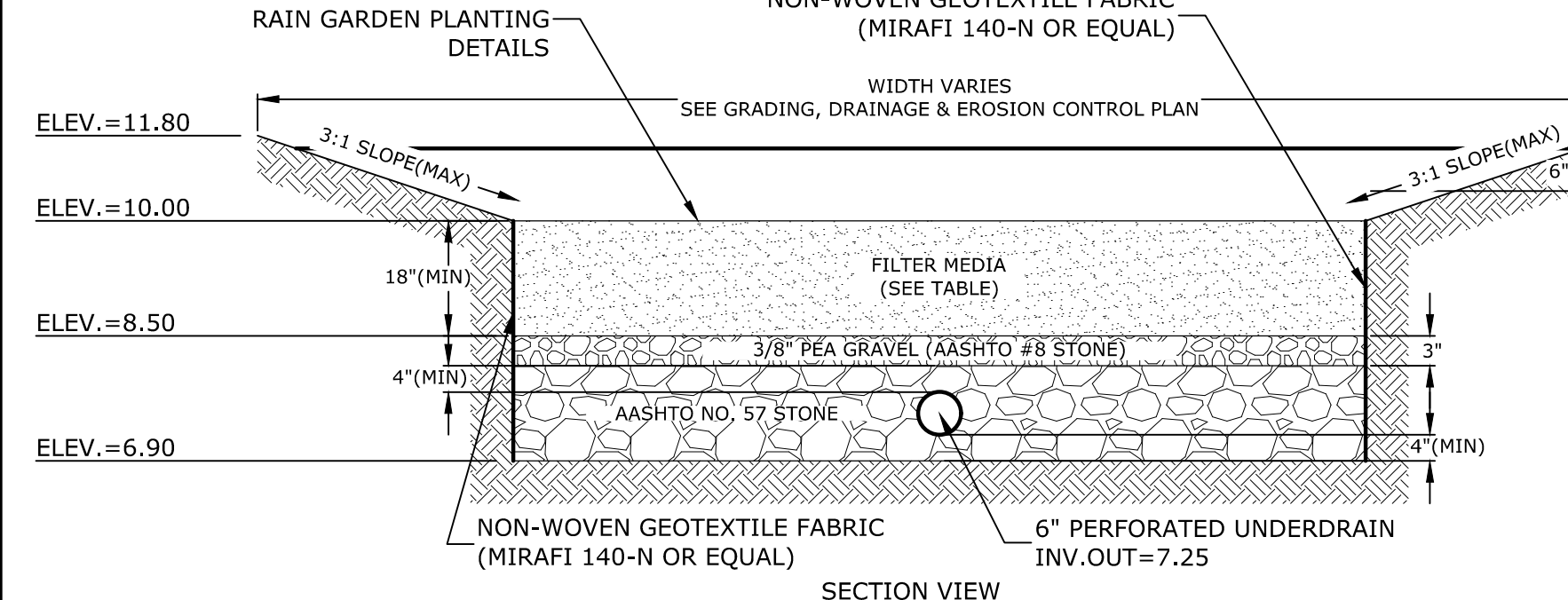

FILTER MEDIA COMPOSITION:

COMPONENT MATERIAL	PERCENT OF MIXTURE BY VOLUME	GRADATION OF MATERIAL
ASTM C-33 CONCRETE SAND	50-55	SEE NOTE #5
LOAMY SAND TOPSOIL	20-30	15-25
MODERATELY FINE SHREDDED BARK OR WOOD FIBER MULCH	20-30	5 MAX

AASHTO #8 STONE (#8 to 3/8")		AASHTO #57 STONE (#4 to 1")	
SIEVE SIZE	% PASSING	SIEVE SIZE	% PASSING
1/2"	100	1-1/2"	100
3/8"	85-100	1"	95-100
#4	10-30	1/2"	25-60
#8	0-10	#4	0-10
#16	0-5	#8	0-5

RAIN GARDEN
NO SCALE

- NOTES:**
1. RAIN GARDENS SHALL NOT BE PLACED INTO SERVICE UNTIL THE PRACTICE HAS BEEN PLANTED AND ITS CONTRIBUTING AREAS HAVE BEEN FULLY STABILIZED. DO NOT TRAFFIC EXPOSED SOIL SURFACES WITH CONSTRUCTION EQUIPMENT. CONTRACTOR SHALL KEEP ALL EXCAVATION EQUIPMENT OUTSIDE OF THE LIMIT OF THE RAIN GARDEN.
 2. SEE GRADING, DRAINAGE & EROSION CONTROL PLAN FOR LOCATIONS, LAYOUTS, AND ELEVATIONS.
 3. THE SAND PORTION OF THE FILTER MEDIA SHALL MEET THE FOLLOWING GRADATION (ASTM C-33):
- | SIEVE SIZE | PERCENT PASSING |
|------------|-----------------|
| 3/8" | 100 |
| #4 | 95-100 |
| #8 | 80-100 |
| #16 | 50-85 |
| #30 | 25-60 |
| #50 | 5-30 |
| #100 | 0-10 |

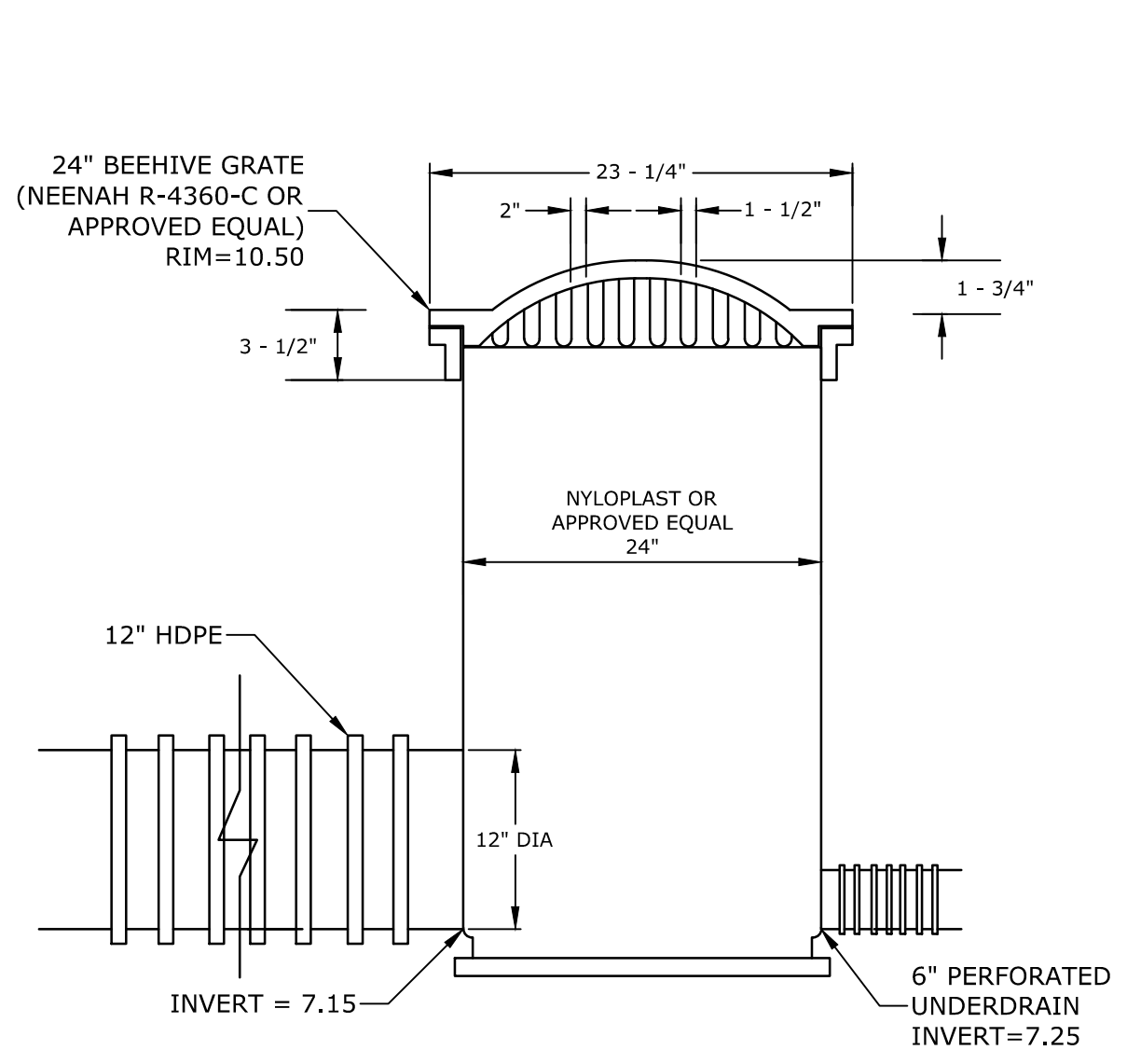

OUTLET STRUCTURE (POS1) DETAIL
NO SCALE

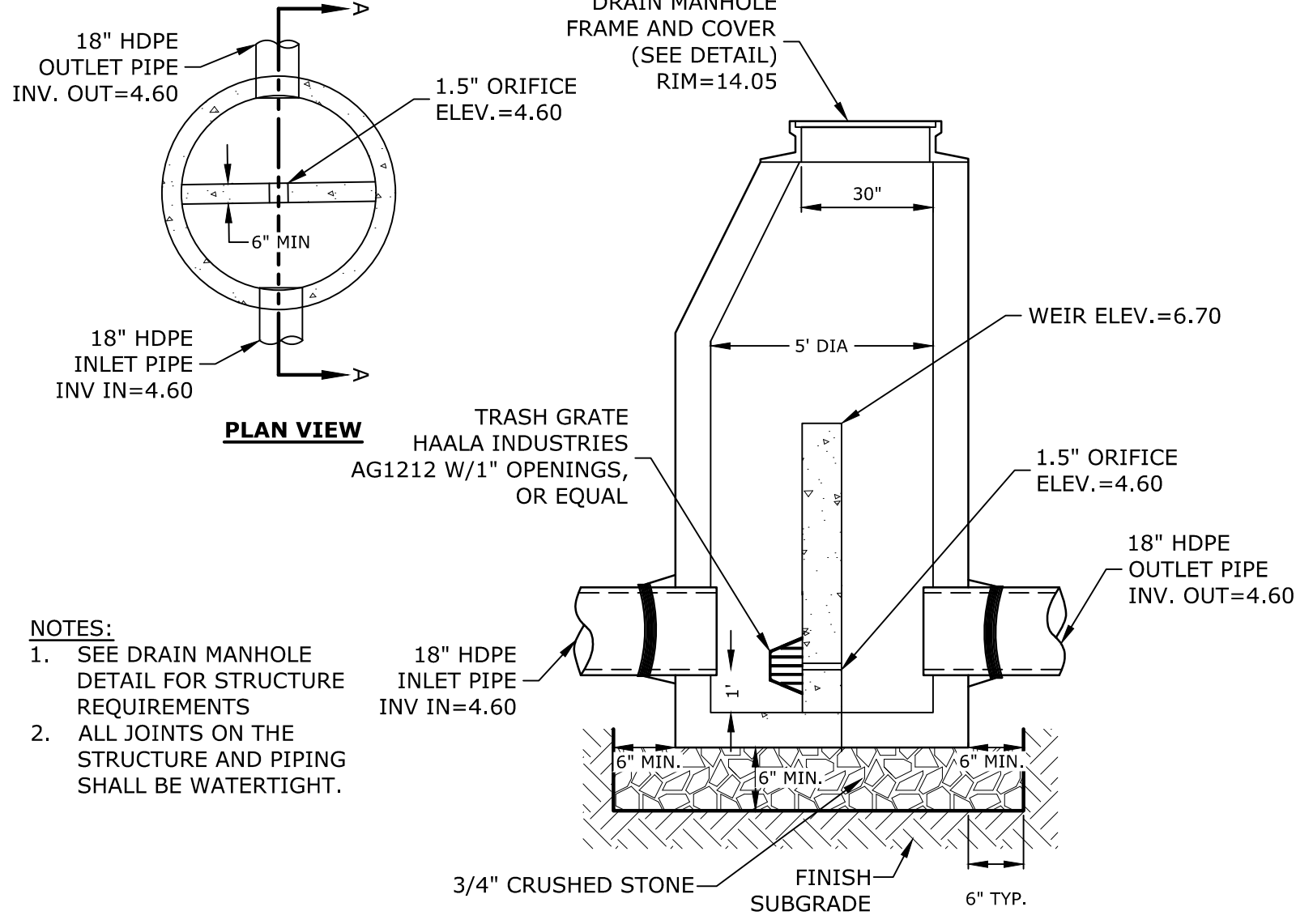

PDMH9 (5' DIA)
NO SCALE

Last Saved: 3/9/2021 1:41:50pm By: N.Hansens
Plotted On: Mar 09, 2021 1:41:50pm
Tighe & Bond: F:\C:\C:\C:\C:\C:\C:\C:\C:\C:\C:\C:\C:\C:\C\0960-008_C-DTLS.dwg

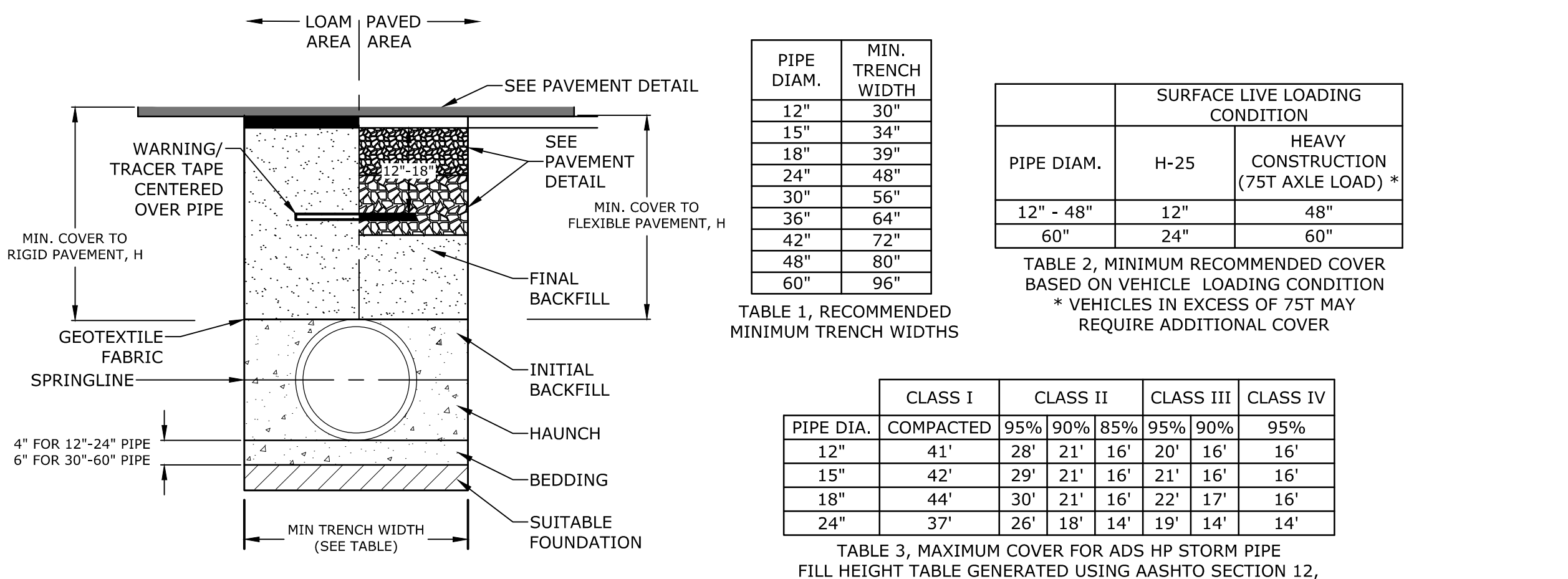
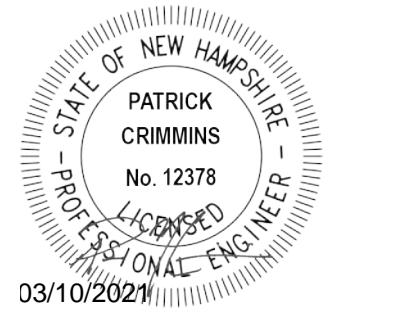

PIPE DIAM.	MIN. TRENCH WIDTH
12"	30"
15"	34"
18"	39"
24"	48"
30"	56"
36"	64"
42"	72"
48"	80"
60"	96"

TABLE 1, RECOMMENDED MINIMUM TRENCH WIDTHS

PIPE DIAM.	SURFACE LIVE LOADING CONDITION	
	H-25	HEAVY CONSTRUCTION (75T AXLE LOAD) *
12" - 48"	12"	48"
60"	24"	60"

TABLE 2, MINIMUM RECOMMENDED COVER BASED ON VEHICLE LOADING CONDITION * VEHICLES IN EXCESS OF 75T MAY REQUIRE ADDITIONAL COVER

PIPE DIA.	CLASS I COMPACTED	CLASS II			CLASS III			CLASS IV		
		95%	90%	85%	95%	90%	95%	90%	95%	
12"	41'	28'	21'	16'	20'	16'	16'	16'	16'	16'
15"	42'	29'	21'	16'	21'	16'	16'	16'	16'	16'
18"	44'	30'	21'	16'	22'	17'	16'	16'	16'	16'
24"	37'	26'	18'	14'	19'	14'	14'	14'	14'	14'

TABLE 3, MAXIMUM COVER FOR ADS HP STORM PIPE FILL HEIGHT TABLE GENERATED USING AASHTO SECTION 12, LOAD RESISTANCE FACTOR DESIGN (LRFD) PROCEDURE WITH THE FOLLOWING ASSUMPTIONS: NO HYDROSTATIC PRESSURE UNIT WEIGHT OF SOIL (γs) = 120 PCF

NOTES:

- ALL PIPE SYSTEMS SHALL BE INSTALLED IN ACCORDANCE WITH ASTM D2321, "STANDARD PRACTICE FOR UNDERGROUND INSTALLATION OF THERMOPLASTIC PIPE FOR SEWERS AND OTHER GRAVITY FLOW APPLICATIONS", LATEST ADDITION, WITH THE EXCEPTION THAT THE INITIAL BACKFILL MAY EXTEND TO THE CROWN OF THE PIPE. SOIL CLASSIFICATIONS ARE PER THE LATEST VERSION OF ASTM D2321. CLASS I/IV MATERIALS (MH, CH) AS DEFINED IN PREVIOUS VERSIONS OF ASTM D2321 ARE NOT APPROPRIATE BACKFILL MATERIALS.
- MEASURES SHOULD BE TAKEN TO PREVENT MIGRATION OF NATIVE FINES INTO BACKFILL MATERIAL, WHEN REQUIRED.
- FOUNDATION: WHERE THE TRENCH BOTTOM IS UNSTABLE AS JUDGED BY THE ENGINEER, THE CONTRACTOR SHALL EXCAVATE TO A DEPTH REQUIRED BY THE ENGINEER AND REPLACE WITH SUITABLE MATERIAL AS SPECIFIED BY THE ENGINEER. AS AN ALTERNATIVE AND AT THE DISCRETION OF THE DESIGN ENGINEER, THE TRENCH BOTTOM MAY BE STABILIZED USING A GEOTEXTILE MATERIAL. REFER TO SPECIFICATION 310000 EARTHWORK - SITE.
- BEDDING: SUITABLE MATERIAL SHALL BE CLASS I, II, III, OR IV. THE CONTRACTOR SHALL PROVIDE DOCUMENTATION FOR MATERIAL SPECIFICATION TO ENGINEER. COMPACTION SHALL BE SPECIFIED BY THE ENGINEER IN ACCORDANCE WITH TABLE 3 FOR THE APPLICABLE FILL HEIGHTS LISTED. UNLESS OTHERWISE NOTED BY THE ENGINEER, MINIMUM BEDDING THICKNESS SHALL BE 4" (100mm) FOR 12"-24" (300mm-600mm) DIAMETER PIPE; 6" (150mm) FOR 30"-60" (750mm-1500mm) DIAMETER PIPE. THE MIDDLE 1/3 BENEATH THE PIPE INVERT SHALL BE LOOSELY PLACED. PLEASE NOTE, CLASS IV MATERIAL HAS LIMITED APPLICATION AND CAN BE DIFFICULT TO PLACE AND COMPACT; USE ONLY WITH THE APPROVAL OF THE GEOTECHNICAL ENGINEER.
- INITIAL BACKFILL: SUITABLE MATERIAL SHALL BE CLASS I, II, III, OR IV IN THE PIPE ZONE EXTENDING TO THE CROWN OF THE PIPE. THE CONTRACTOR SHALL PROVIDE DOCUMENTATION FOR MATERIAL SPECIFICATION TO ENGINEER. MATERIAL SHALL BE INSTALLED AS REQUIRED IN ASTM D2321, LATEST EDITION. COMPACTION SHALL BE SPECIFIED BY THE ENGINEER IN ACCORDANCE WITH TABLE 3 FOR THE APPLICABLE FILL HEIGHTS LISTED. PLEASE NOTE, CLASS IV MATERIAL HAS LIMITED APPLICATION AND CAN BE DIFFICULT TO PLACE AND COMPACT; USE ONLY WITH THE APPROVAL OF THE GEOTECHNICAL ENGINEER.
- MINIMUM COVER: FOR TRAFFIC APPLICATIONS, MINIMUM COVER, H, IS 12" (300mm) UP TO 48" (1200mm) DIAMETER PIPE AND 24" (600mm) OF COVER FOR 60" (1500mm) DIAMETER PIPE, MEASURED FROM TOP OF PIPE TO BOTTOM OF FLEXIBLE PAVEMENT OR TO TOP OF RIGID PAVEMENT.
- FOR ADDITIONAL INFORMATION SEE TECHNICAL NOTE 2.04.

HP STORM TRENCH INSTALLATION DETAIL

NO SCALE

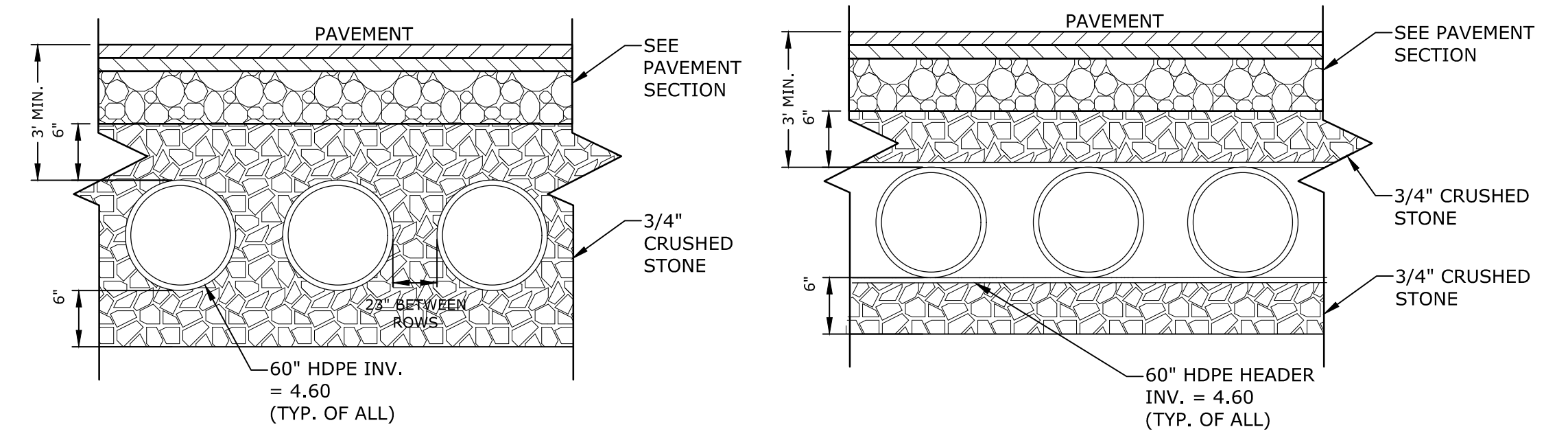

UNDERGROUND DETENTION AREA

HEADER ROW

NOTES:

- UNDERGROUND DETENTION SYSTEM TO BE 60" HDPE PIPE DESIGNED FOR H-20 LOADING. CONTRACTOR TO SUBMIT PIPE SPECIFICATIONS AND FINAL MANUFACTURER DESIGN TO ENGINEER FOR APPROVAL.
- MANUFACTURER TO SUBMIT PLANS STAMPED BY A PROFESSIONAL ENGINEER LICENSED IN THE STATE OF NEW HAMPSHIRE.
- THE DESIGN ENGINEER SHALL PROVIDE SUFFICIENT INSPECTION TO CERTIFY THAT THE SYSTEM HAS BEEN INSTALLED PER THE APPROVED DESIGN PLAN.
- REFER TO STANDARD DUTY PAVEMENT SECTION DETAIL FOR PAVEMENT SECTION.

UNDERGROUND DETENTION SYSTEM DETAIL

NO SCALE

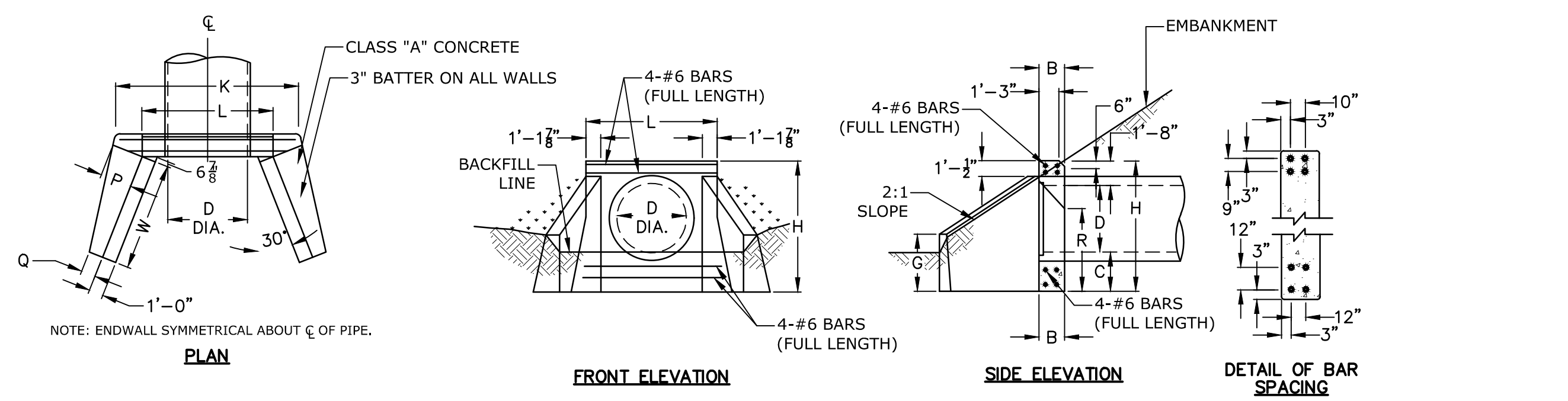

HEADWALL WITH WINGWALLS

NO SCALE

DIMENSIONS AND QUANTITIES FOR ONE WING TYPE ENDWALL												
D	B	C	G	H	K	L	P	Q	R	W	W	VOL.
IN.*	FT-IN	FT-IN	FT-IN	FT-IN	FT-IN	FT-IN	FT-IN	FT-IN	FT-IN	FT-IN	FT-IN	CY
24	1'-6"	2'-0"	3'-3"	6'-9"	9'-1 1/2"	7'-3 3/4"	1'-4 1/2"	0'-9 3/4"	3'-4 1/2"	5'-5 1/2"	5.87	
36	1'-6"	2'-0"	3'-3"	6'-8"	9'-1 1/2"	7'-3 3/4"	1'-4 1/2"	0'-9 3/4"	3'-4 1/2"	5'-5 1/2"	5.87	
42	1'-6"	2'-0"	3'-3"	7'-2"	9'-10 1/4"	7'-9 3/4"	1'-6 1/2"	0'-9 3/4"	3'-10 1/4"	6'-7 1/2"	6.67	

* FOR D < 36" USE DIMENSIONS LISTED FOR D = 36"

OUTLET PLUNGE POOL SIZING						
HW	Do	S	W	L	D50	D
HW1	24"	1.0'	4.0'	6.0'	8"	1.5'
HW2	18"	0.75'	3.0'	5.0'	6"	1.13'
HW3	24"	1.0'	4.0'	6.0'	6"	1.13'

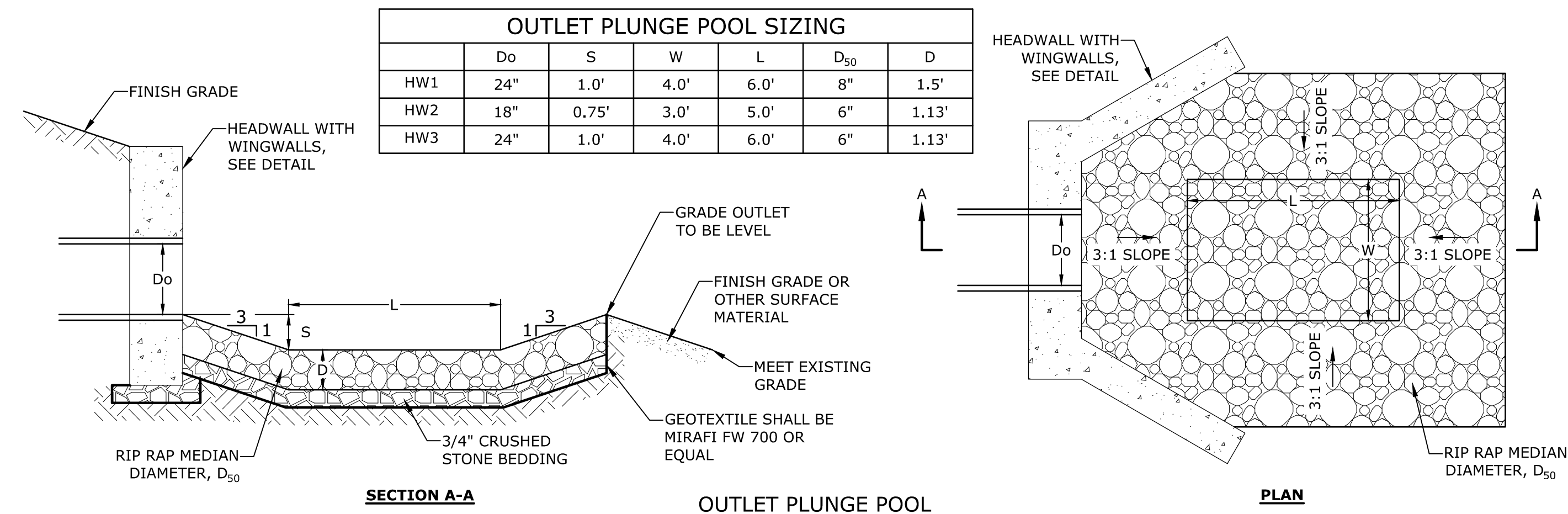

SECTION A-A

OUTLET PLUNGE POOL

NO SCALE

PLAN

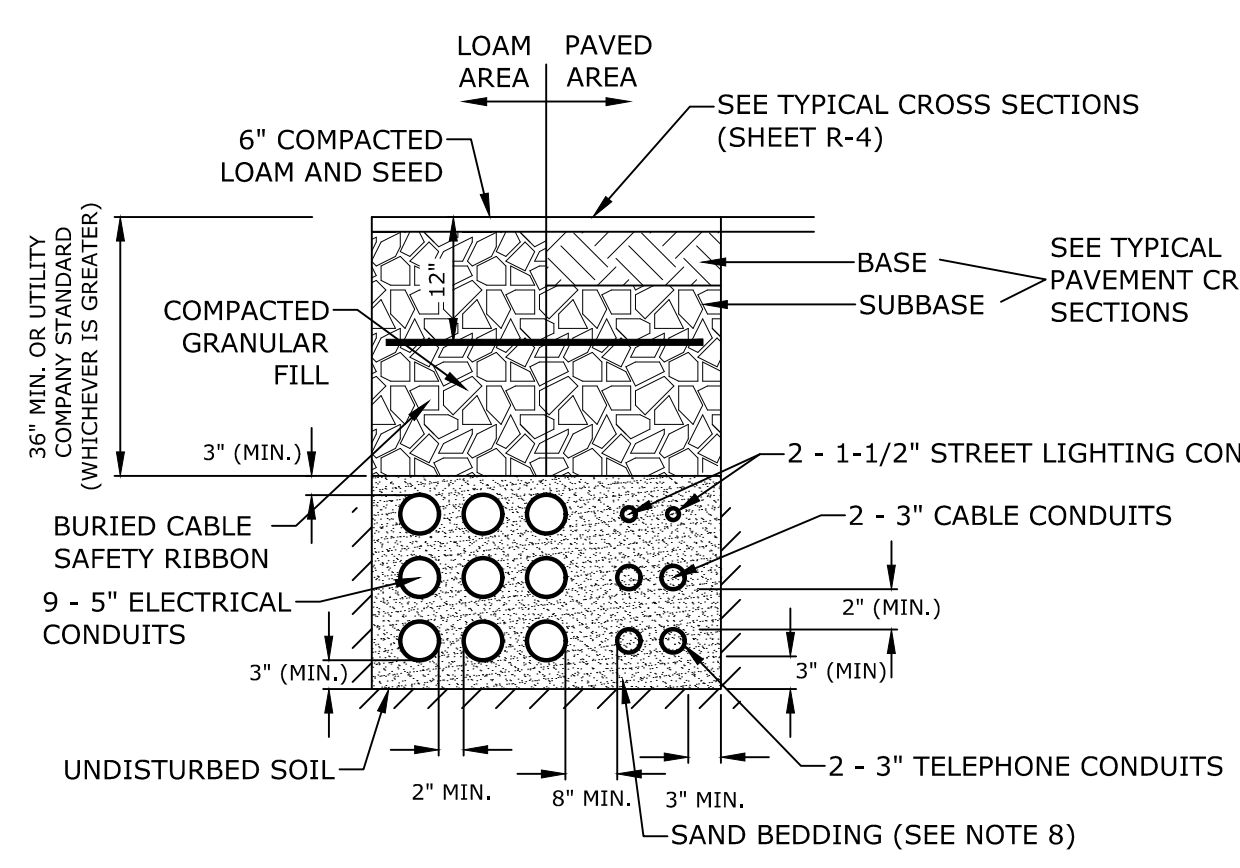

ELECTRICAL AND COMMUNICATION CONDUIT

NO SCALE

NOTES:

- NUMBER, MATERIAL, AND SIZE OF UTILITY CONDUITS TO BE DETERMINED BY LOCAL UTILITY OR AS SHOWN ON ELECTRICAL DRAWINGS. CONTRACTOR TO PROVIDE ONE SPARE CONDUIT FOR EACH UTILITY TO BUILDING.
- DIMENSIONS SHOWN REPRESENT OWNERS MINIMUM REQUIREMENTS. ACTUAL DIMENSIONS MAY BE GREATER BASED ON UTILITY COMPANY STANDARDS, BUT SHALL NOT BE LESS THAN THOSE SHOWN.
- NO CONDUIT RUN SHALL EXCEED 360 DEGREES IN TOTAL BENDS.
- A SUITABLE PULLING STRING, CAPABLE OF 200 POUNDS OF PULL, MUST BE INSTALLED IN THE CONDUIT BEFORE UTILITY COMPANY IS NOTIFIED TO INSTALL CABLE. THE STRING SHOULD BE BLOWN INTO THE CONDUIT AFTER THE RUN IS ASSEMBLED TO AVOID BONDING THE STRING TO THE CONDUIT.
- UTILITY COMPANY MUST BE GIVEN THE OPPORTUNITY TO INSPECT THE CONDUIT PRIOR TO BACKFILL. THE CONTRACTOR IS RESPONSIBLE FOR ALL REPAIRS SHOULD THE UTILITY COMPANY BE UNABLE TO INSTALL ITS CABLE IN A SUITABLE MANNER.
- ALL CONDUIT INSTALLATIONS MUST CONFORM TO THE CURRENT EDITION OF THE NATIONAL ELECTRIC SAFETY CODE, STATE AND LOCAL CODES AND ORDINANCES, AND, WHERE APPLICABLE, THE NATIONAL ELECTRIC CODE. ALL 90° SWEEPS WILL BE MADE USING RIGID GALVANIZED STEEL SWEEPS WITH A 36 TO 48 INCH RADIUS.
- SAND BEDDING TO BE REPLACED WITH CONCRETE ENCASEMENT WHERE COVER IS LESS THAN 3 FEET, WHEN LOCATED BELOW PAVEMENT, OR WHERE SHOWN ON THE UTILITIES PLAN.

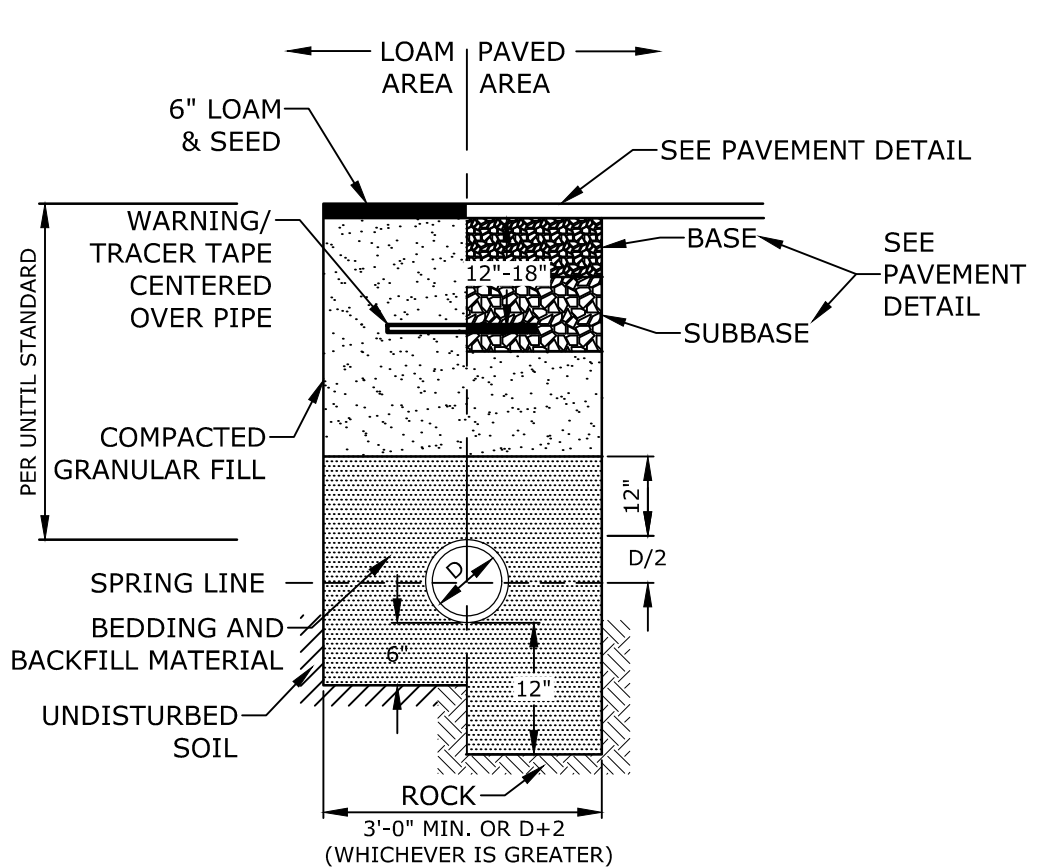

GAS TRENCH

NO SCALE

NOTE:

- SAND BEDDING AND BACKFILL FOR FULL WIDTH OF THE TRENCH FROM 6" BELOW PIPE IN EARTH AND 12" BELOW PIPE IN ROCK UP TO 12" ABOVE TOP OF PIPE.
- GAS SHALL BE INSTALLED PER UNTIL STANDARDS. COORDINATE ALL INSTALLATIONS WITH UNTIL AND THE CITY OF PORTSMOUTH.

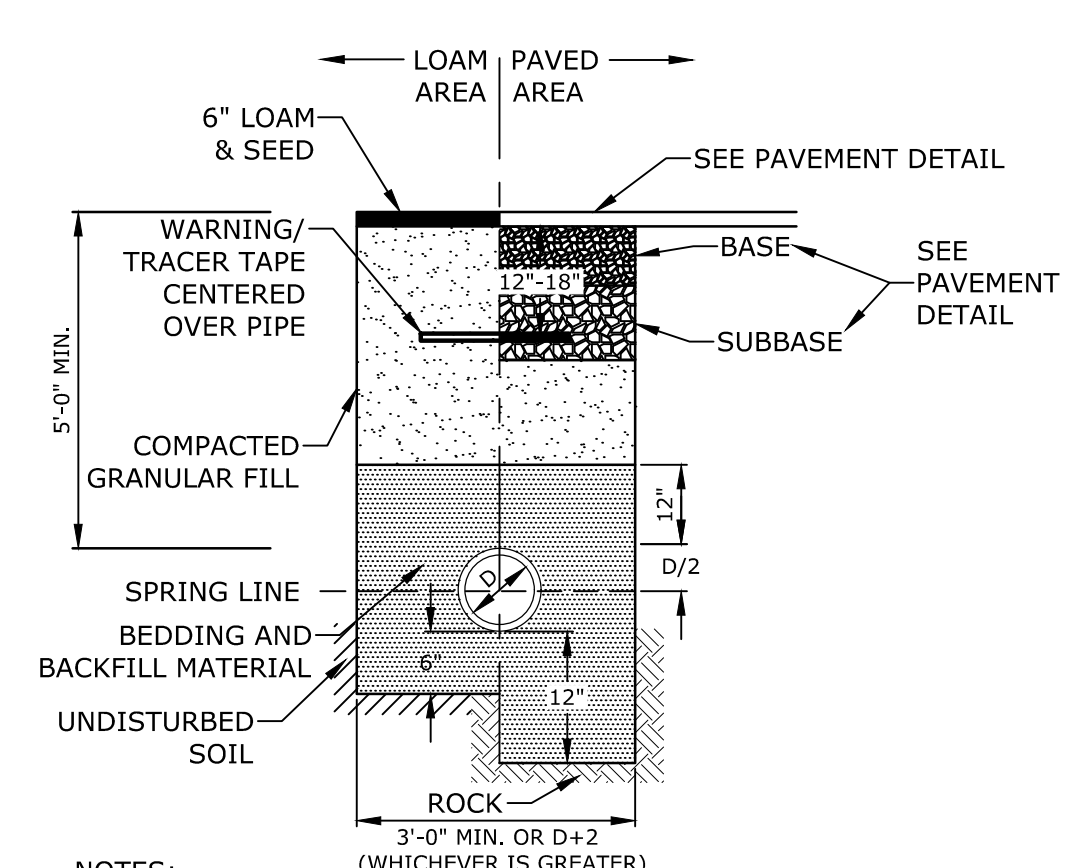

WATER TRENCH

NO SCALE

NOTES:

- SAND BEDDING AND BACKFILL FOR FULL WIDTH OF THE TRENCH FROM 6" BELOW PIPE IN EARTH AND 12" BELOW PIPE IN ROCK UP TO 12" ABOVE TOP OF PIPE.
- WATER MAIN SHALL BE INSTALLED PER CITY OF PORTSMOUTH STANDARDS. COORDINATE ALL INSTALLATIONS WITH THE CITY OF PORTSMOUTH.
- WATER MAIN TO BE PLACED IN A PROTECTIVE POLYWRAP AND INSTALLED WITH 3 CONTINUITY WEDGES PER JOINT.

Proposed Multi-Family Development

Iron Horse Properties, LLC

105 Bartlett Street
Portsmouth,
New Hampshire

MARK	DATE	DESCRIPTION
I	3/10/2021	PB Submission
H	1/20/2021	TAC Resubmission
G	11/18/2020	TAC Resubmission
F	10/28/2020	Wetland CUP Resubmission
E	5/20/2020	TAC Resubmission
D	4/29/2020	Wetland CUP Submission
C	4/20/2020	TAC Submission
B	2/6/2020	Design Review Submission
A	1/2/2020	ZBA Submission

PROJECT NO:	C-0960-008
DATE:	April 20, 2020
FILE:	C-0960-008_C-DTLS.DWG
DRAWN BY:	NAH
CHECKED:	PMC
APPROVED:	BML

DETAILS SHEET

SCALE: AS SHOWN

C-507

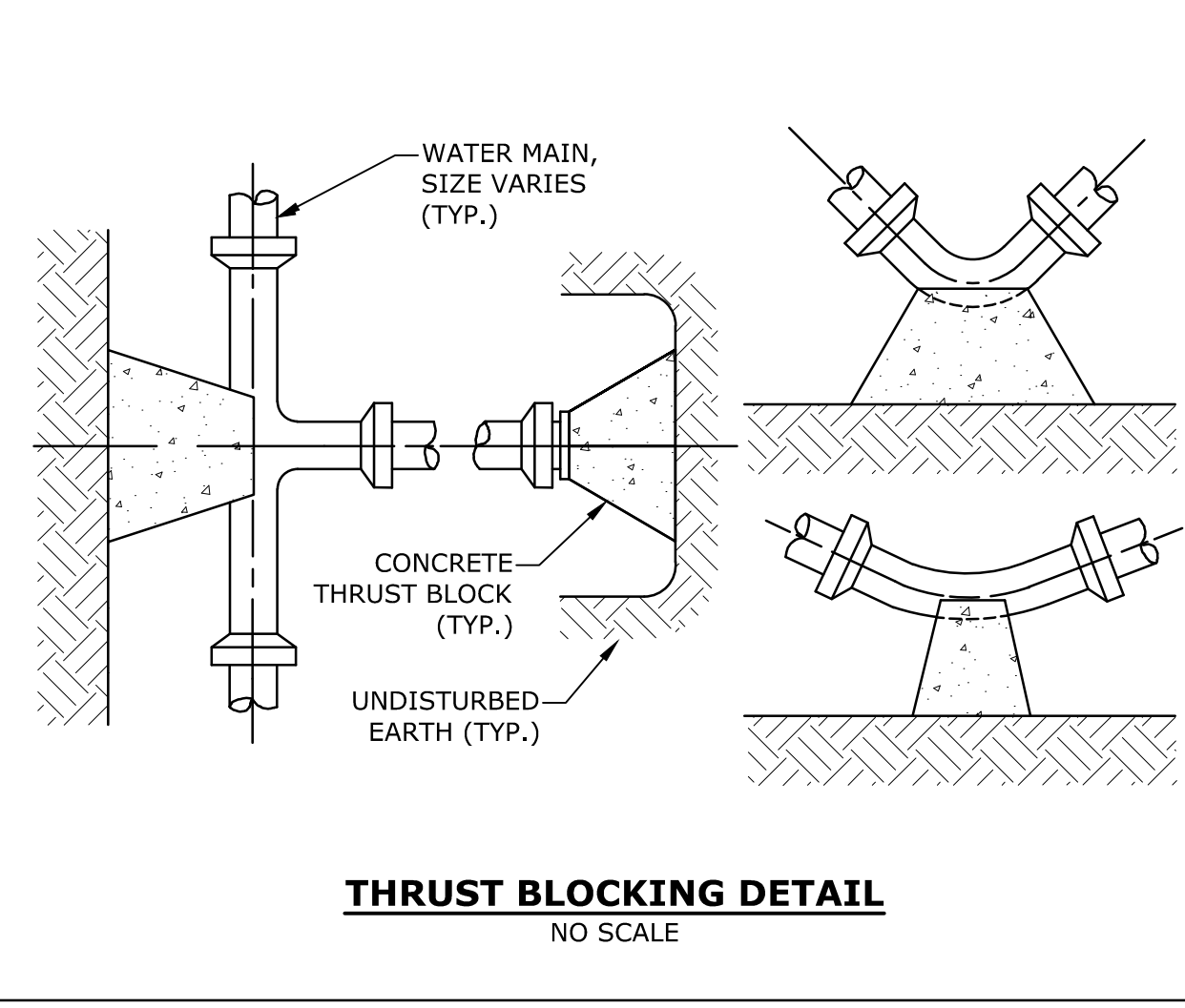
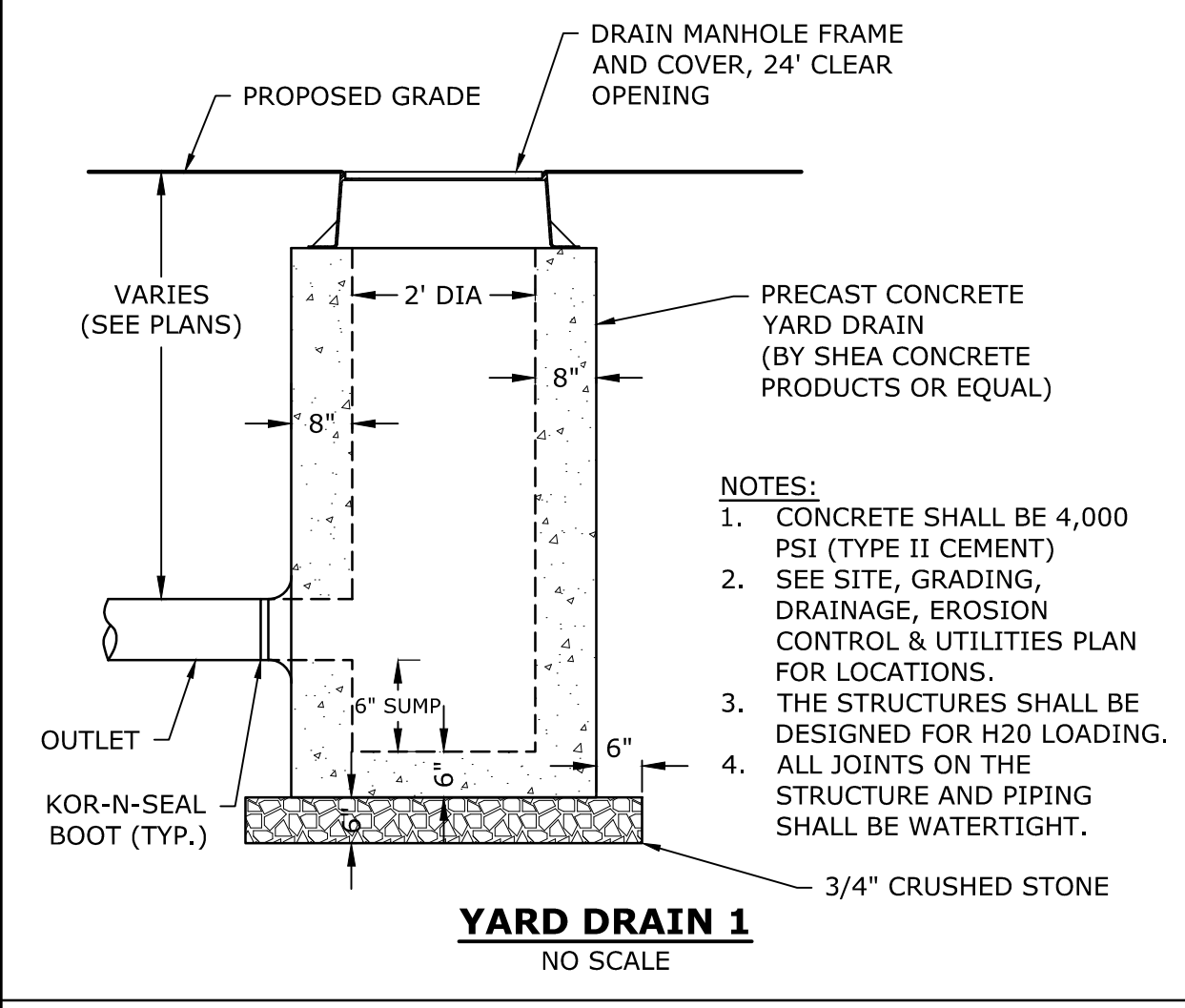

REACTION TYPE	PIPE SIZE				
	4"	6"	8"	10"	12"
A 90°	0.89	2.19	3.82	11.14	17.24
B 180°	0.65	1.55	2.78	8.38	12.00
C 45°	0.48	1.19	2.12	6.02	9.32
D 22-1/2°	0.25	0.60	1.06	3.08	4.74
E 11-1/4°	0.13	0.30	0.54	1.54	2.38

TEST PRESSURE = 200psi

- NOTES:
- POUR THRUST BLOCKS AGAINST UNDISTURBED MATERIAL, WHERE TRENCH WALL HAS BEEN DISTURBED, EXCAVATE LOOSE MATERIAL AND EXTEND THRUST BLOCK TO UNDISTURBED MATERIAL. NO JOINTS SHALL BE COVERED WITH CONCRETE.
 - ON BENDS AND TEES, EXTEND THRUST BLOCKS FULL LENGTH OF FITTING.
 - PLACE BOARD IN FRONT OF ALL PLUGS BEFORE POURING THRUST BLOCKS.
 - WHERE M.J. PIPE IS USED, M.J. PLUG WITH RETAINER GLAND MAY BE SUBSTITUTED FOR END BLOCKINGS.
 - INSTALLATION AND STANDARD DIMENSIONAL REQUIREMENTS SHALL BE WITH CITY OF PORTSMOUTH WATER DEPARTMENT STANDARDS.

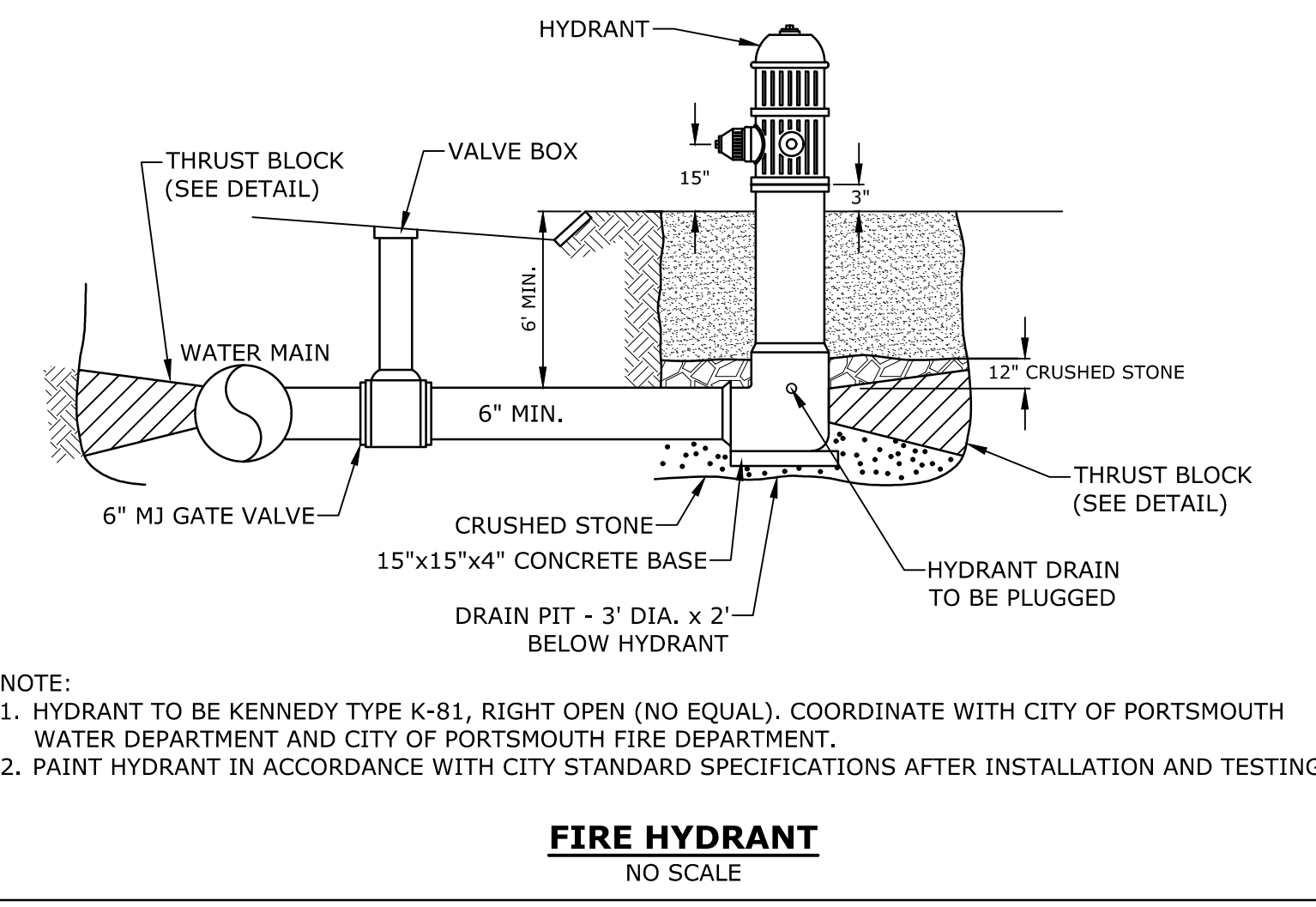

- NOTE:
- HYDRANT TO BE KENNEDY TYPE K-81, RIGHT OPEN (NO EQUAL). COORDINATE WITH CITY OF PORTSMOUTH WATER DEPARTMENT AND CITY OF PORTSMOUTH FIRE DEPARTMENT.
 - PAINT HYDRANT IN ACCORDANCE WITH CITY STANDARD SPECIFICATIONS AFTER INSTALLATION AND TESTING.

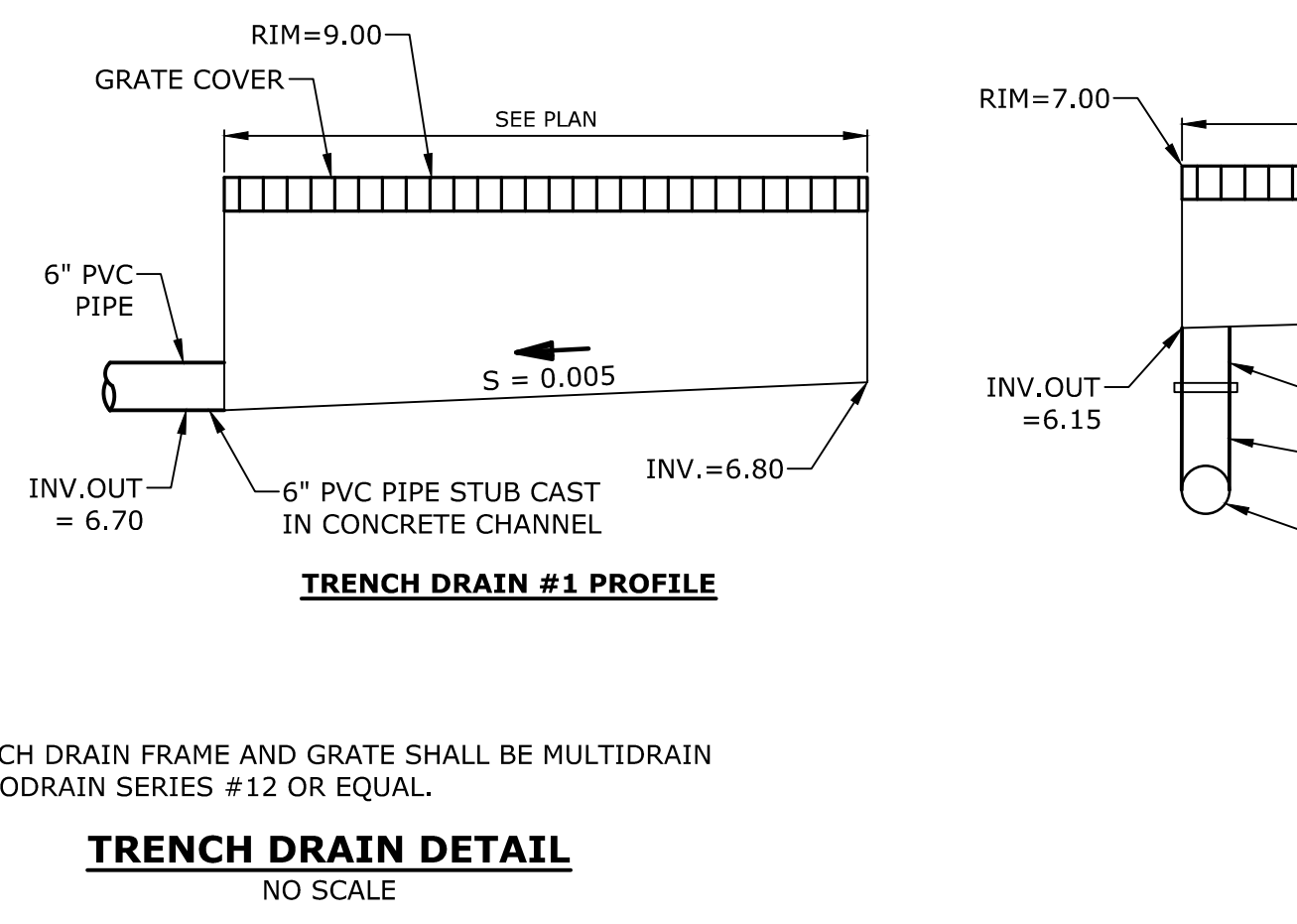
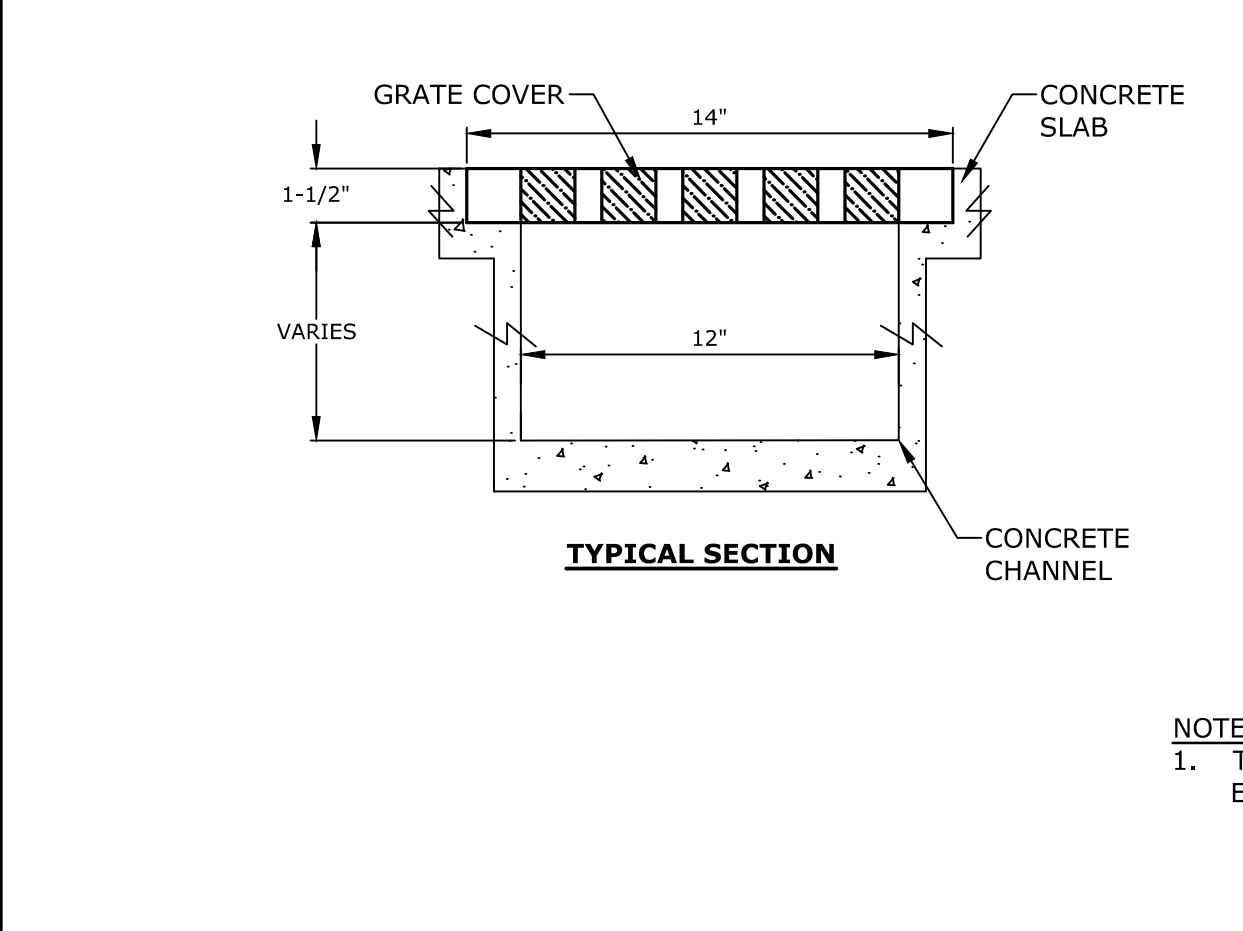

- NOTES:
- TRENCH DRAIN FRAME AND GRATE SHALL BE MULTIDRAIN ECONODRAIN SERIES #12 OR EQUAL.

TRENCH DRAIN DETAIL
NO SCALE

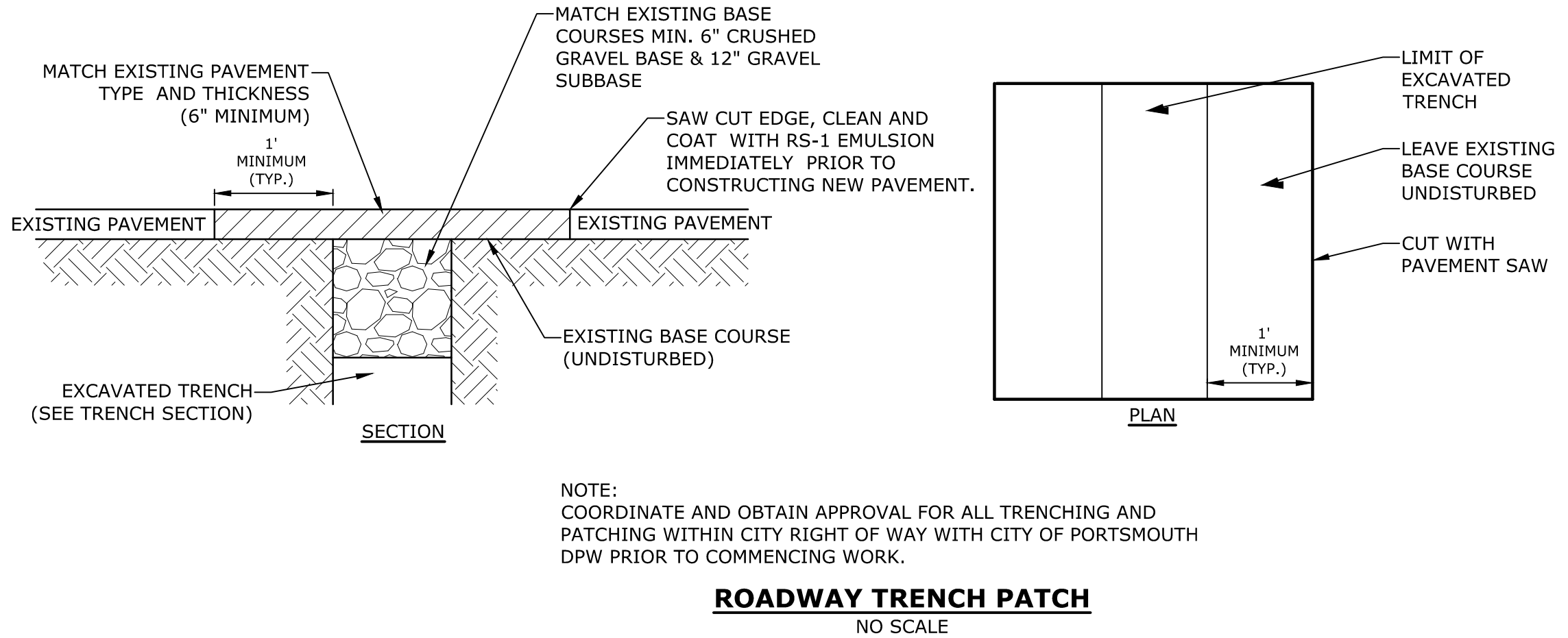

- NOTE:
- COORDINATE AND OBTAIN APPROVAL FOR ALL TRENCHING AND PATCHING WITHIN CITY RIGHT OF WAY WITH CITY OF PORTSMOUTH DPW PRIOR TO COMMENCING WORK.

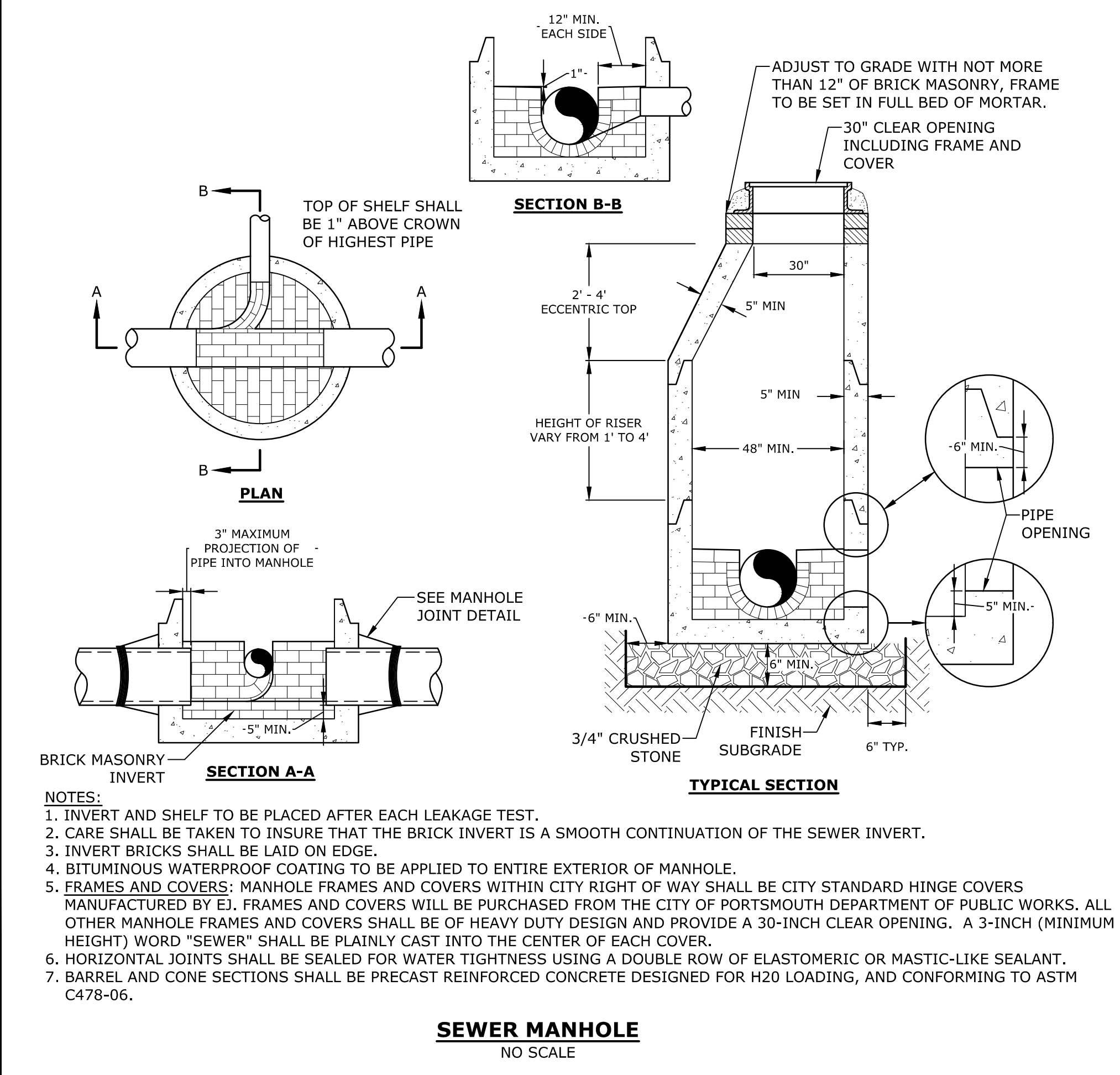

- NOTES:
- INVERT AND SHELF TO BE PLACED AFTER EACH LEAKAGE TEST.
 - CARE SHALL BE TAKEN TO INSURE THAT THE BRICK INVERT IS A SMOOTH CONTINUATION OF THE SEWER INVERT.
 - INVERT BRICKS SHALL BE LAID ON EDGE.
 - BITUMINOUS WATERPROOF COATING TO BE APPLIED TO ENTIRE EXTERIOR OF MANHOLE.
 - FRAMES AND COVERS: MANHOLE FRAMES AND COVERS WITHIN CITY RIGHT OF WAY SHALL BE CITY STANDARD HINGE COVERS MANUFACTURED BY E.J. FRAMES AND COVERS WILL BE PURCHASED FROM THE CITY OF PORTSMOUTH DEPARTMENT OF PUBLIC WORKS. ALL OTHER MANHOLE FRAMES AND COVERS SHALL BE OF HEAVY DUTY DESIGN AND PROVIDE A 30-INCH CLEAR OPENING. A 3-INCH (MINIMUM HEIGHT) WORD "SEWER" SHALL BE PLAINLY CAST INTO THE CENTER OF EACH COVER.
 - HORIZONTAL JOINTS SHALL BE SEALED FOR WATER TIGHTNESS USING A DOUBLE ROW OF ELASTOMERIC OR MASTIC-LIKE SEALANT.
 - BARREL AND CONE SECTIONS SHALL BE PRECAST REINFORCED CONCRETE DESIGNED FOR H2O LOADING, AND CONFORMING TO ASTM C478-06.

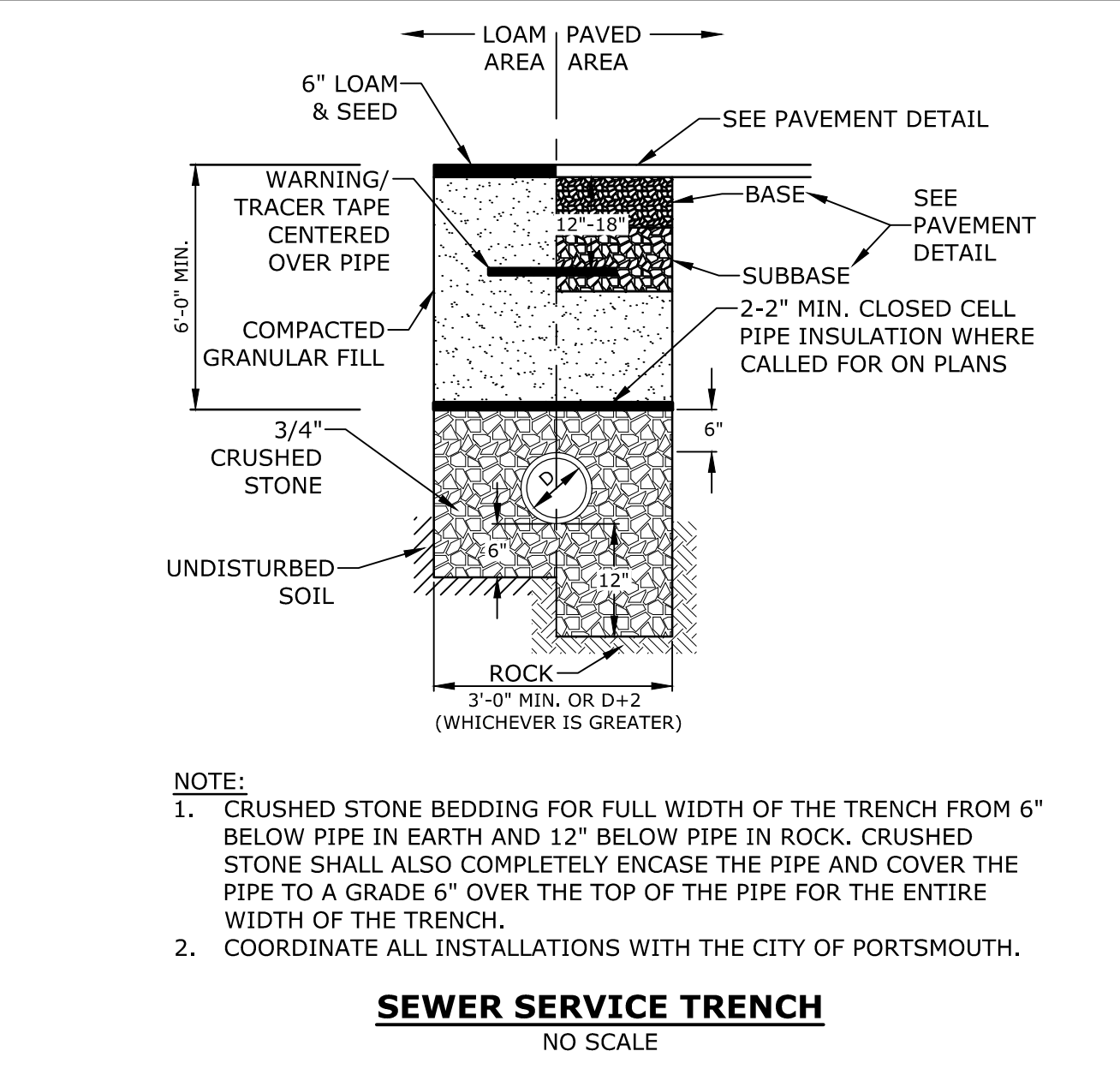
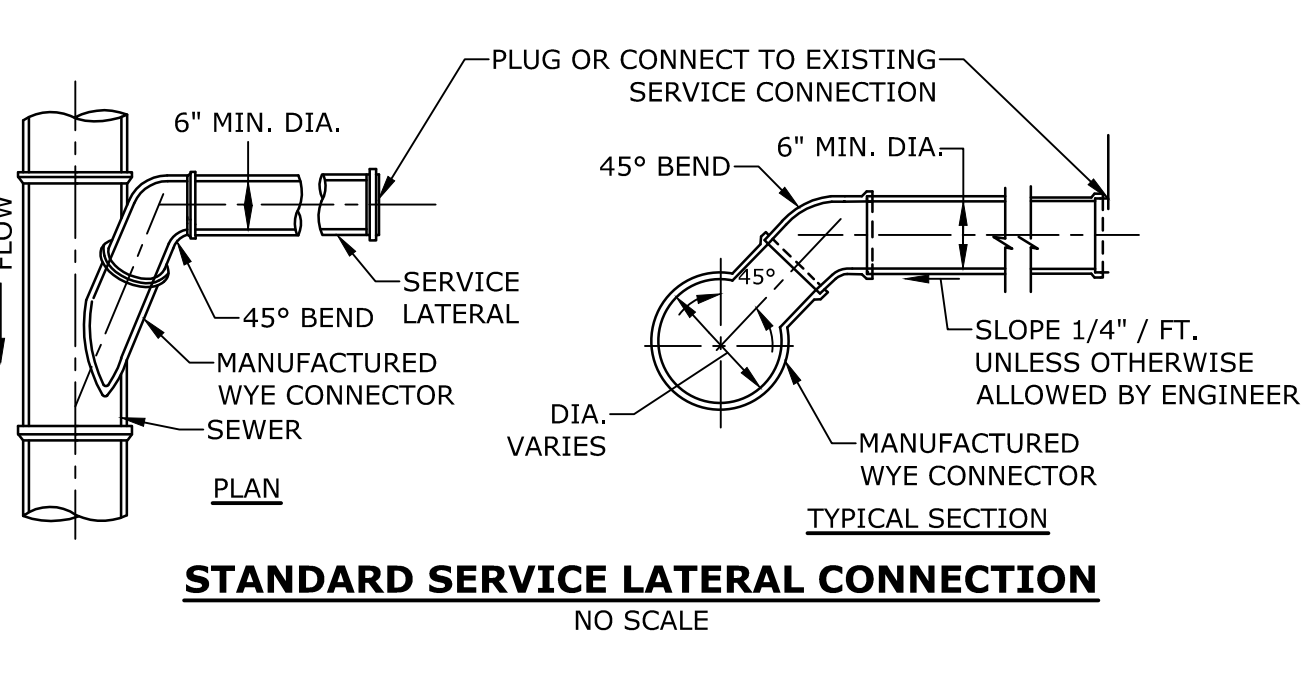

- NOTE:
- CRUSHED STONE BEDDING FOR FULL WIDTH OF THE TRENCH FROM 6" BELOW PIPE IN EARTH AND 12" BELOW PIPE IN ROCK. CRUSHED STONE SHALL ALSO COMPLETELY ENCASE THE PIPE AND COVER THE PIPE TO A GRADE 6" OVER THE TOP OF THE PIPE FOR THE ENTIRE WIDTH OF THE TRENCH.
 - COORDINATE ALL INSTALLATIONS WITH THE CITY OF PORTSMOUTH.

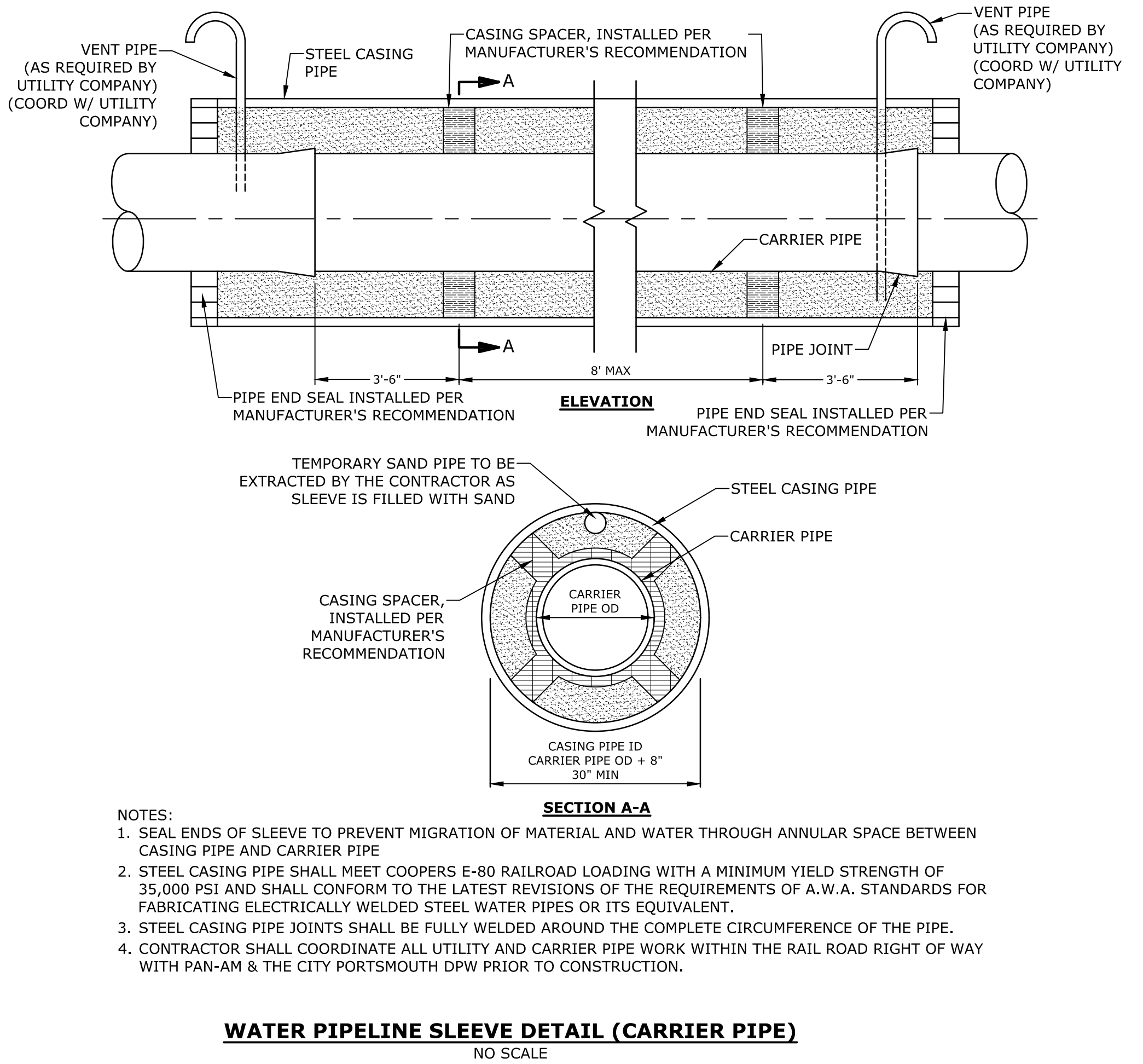

- NOTES:
- SEAL ENDS OF SLEEVE TO PREVENT MIGRATION OF MATERIAL AND WATER THROUGH ANNULAR SPACE BETWEEN CASING PIPE AND CARRIER PIPE
 - STEEL CASING PIPE SHALL MEET COOPERS E-80 RAILROAD LOADING WITH A MINIMUM YIELD STRENGTH OF 35,000 PSI AND SHALL CONFORM TO THE LATEST REVISIONS OF THE REQUIREMENTS OF A.W.A. STANDARDS FOR FABRICATING ELECTRICALLY WELDED STEEL WATER PIPES OR ITS EQUIVALENT.
 - STEEL CASING PIPE JOINTS SHALL BE FULLY WELDED AROUND THE COMPLETE CIRCUMFERENCE OF THE PIPE.
 - CONTRACTOR SHALL COORDINATE ALL UTILITY AND CARRIER PIPE WORK WITHIN THE RAIL ROAD RIGHT OF WAY WITH PAN-AM & THE CITY PORTSMOUTH DPW PRIOR TO CONSTRUCTION.

Proposed
Multi-Family
Development

Iron Horse
Properties, LLC

105 Bartlett Street
Portsmouth,
New Hampshire

MARK	DATE	DESCRIPTION
I	3/10/2021	PB Submission
H	1/20/2021	TAC Resubmission
G	11/18/2020	TAC Resubmission
F	10/28/2020	Wetland CUP Resubmission
E	5/20/2020	TAC Resubmission
D	4/29/2020	Wetland CUP Submission
C	4/20/2020	TAC Submission
B	2/6/2020	Design Review Submission
A	1/2/2020	ZBA Submission

PROJECT NO: C-0960-006
DATE: April 20, 2020
FILE: C-0960-006_C-DTLS.DWG
DRAWN BY: NAH
CHECKED: PMC
APPROVED: BML

DETAILS SHEET

SCALE: AS SHOWN

C-508

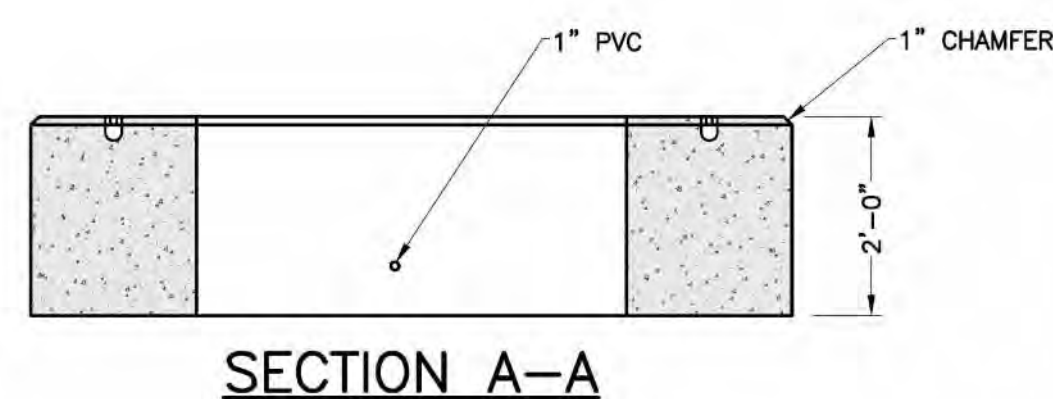
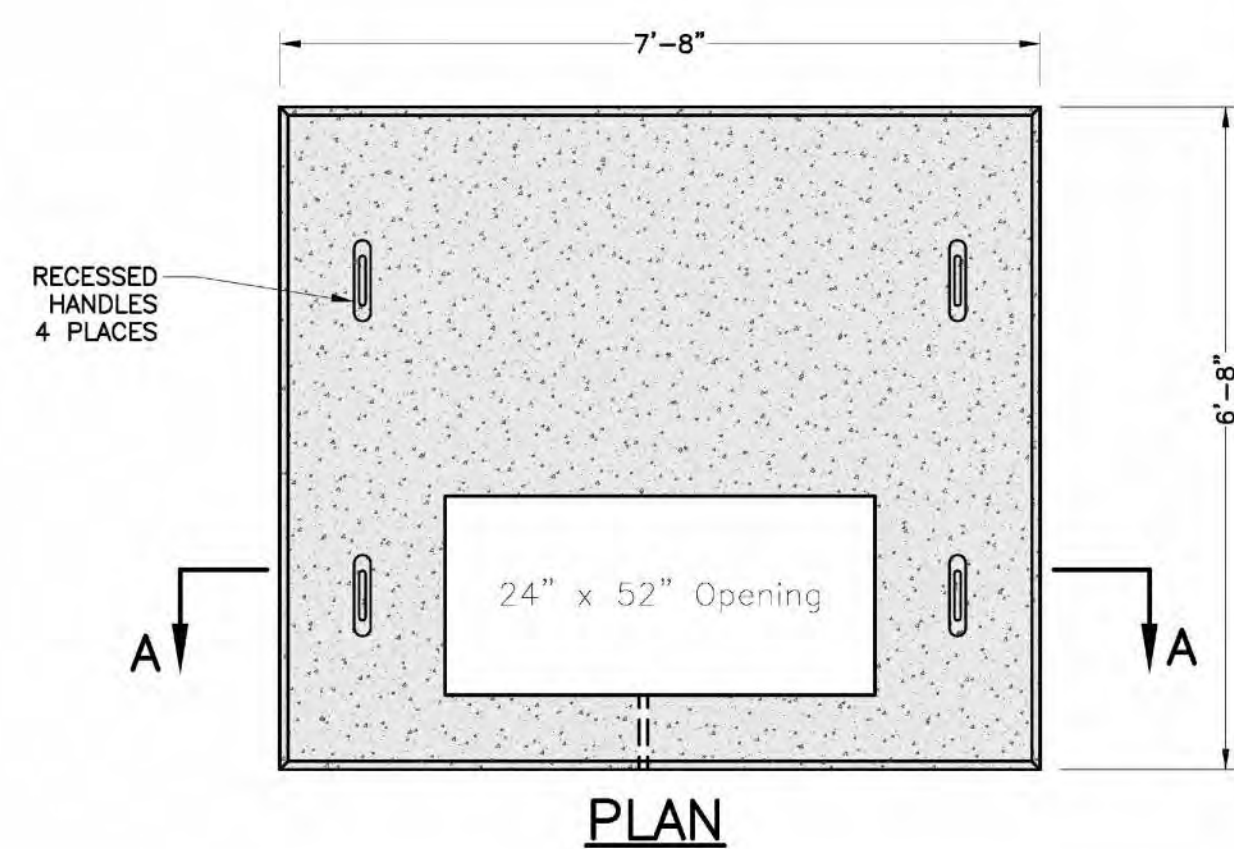

3-PHASE TRANSFORMER PAD
NO SCALE

- NOTES:**
1. DIMENSIONS SHOWN REPRESENT TYPICAL REQUIREMENTS. MANHOLE LOCATIONS AND REQUIREMENTS SHALL BE COORDINATED WITH EVERSOURCE PRIOR TO CONSTRUCTION
 2. CONCRETE MINIMUM STRENGTH - 4,000 PSI @ 28 DAYS
 3. STEEL REINFORCEMENT - ASTM A615, GRADE 60
 4. PAD MEETS OR EXCEEDS EVERSOURCE SPECIFICATIONS

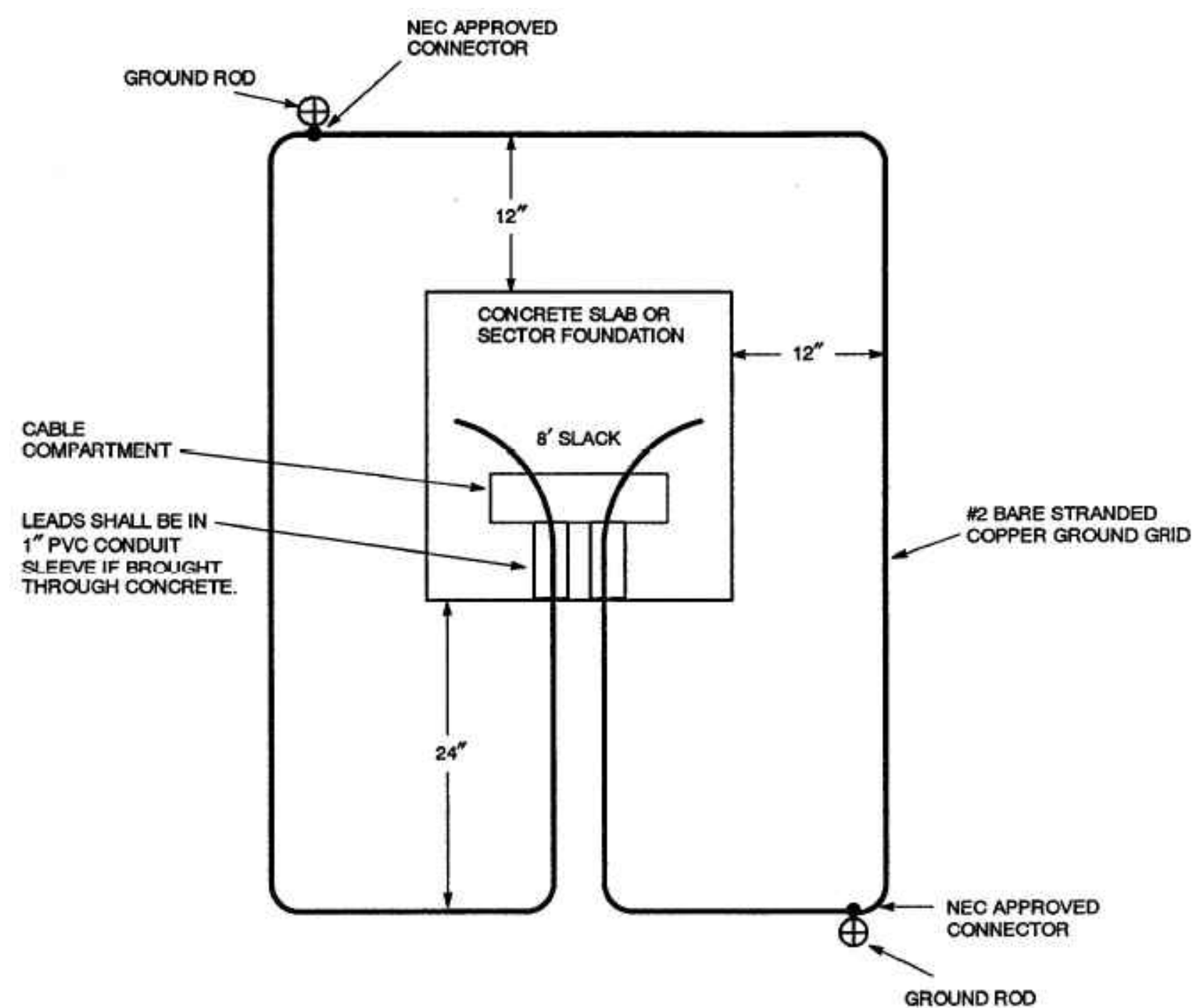
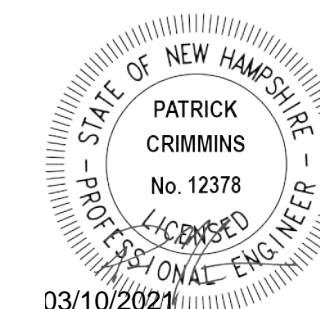

- NOTES:**
- THE GROUND GRID SHALL BE SUPPLIED AND INSTALLED BY THE CONTRACTOR AND IS TO BE BURIED AT LEAST 12 INCHES BELOW GRADE. EIGHT FEET OF EXTRA WIRE FOR EACH GROUND GRID LEG SHALL BE LEFT EXPOSED IN THE CABLE COMPARTMENT TO ALLOW FOR THE CONNECTION TO THE TRANSFORMER. THE TWO 8-FOOT GROUND RODS MAY BE EITHER GALVANIZED STEEL OR COPPERWELD AND THEY SHALL BE CONNECTED TO THE GRID WITH NEC APPROVED CONNECTORS.

PAD-MOUNTED EQUIPMENT GROUNDING GRID DETAIL
NO SCALE

Proposed
Multi-Family
Development

Iron Horse
Properties, LLC

105 Bartlett Street
Portsmouth,
New Hampshire

MARK	DATE	DESCRIPTION
I	3/10/2021	PB Submission
H	1/20/2021	TAC Resubmission
G	11/18/2020	TAC Resubmission
F	10/28/2020	Wetland CUP Resubmission
E	5/20/2020	TAC Resubmission
D	4/29/2020	Wetland CUP Submission
C	4/20/2020	TAC Submission
B	2/6/2020	Design Review Submission
A	1/2/2020	ZBA Submission

PROJECT NO:	C-0960-006
DATE:	April 20, 2020
FILE:	C-0960-006_C-DTLS.DWG
DRAWN BY:	NAH
CHECKED:	PMC
APPROVED:	BML

DETAILS SHEET

SCALE: AS SHOWN

C-509

Plant List

Symbol	Botanical Name	Common Name	Quantity	Size	Comments
Am	<i>Amelanchier canadensis</i>	Shadbowl Serviceberry	2	2.5-3" Cal	B&B
Ar	<i>Acer rubrum</i> 'October Glory'	October Glory Red Maple	1	2.5-3" Cal	B&B
As	<i>Acer saccharum</i> 'Green Mountain'	Green Mountain Sugar Maple	1	2.5-3" Cal	B&B
Bn	<i>Betula nigra</i> 'Heritage'	Heritage River Birch	8	8-10" Ht	Multi-stem, B&B
Cb	<i>Carpinus carolinianum</i>	American Hornbeam	2	2.5-3" Cal	B&B
Gt	<i>Ginkgo biloba</i> 'Autumn Gold'	Autumn Gold Ginkgo	4	2.5-3" Cal	B&B
Gl	<i>Gleditsia triacanthos</i> 'Inermis	Halka Thornless Honeylocust	2	2.5-3" Cal	B&B
Ham	<i>Hamelis x intermedia</i> 'Arnold promise'	Arnold Promise Witchhazel	1	8-10" Ht	Multi-stem, B&B
Ls	<i>Liquidambar styraciflua</i>	American Sweetgum	5	2.5-3" Cal	B&B
Lt	<i>Liriodendron tulipifera</i>	Tuliptree	5	2.5-3" Cal	B&B
Mal	<i>Malus</i> 'Sugar Tyme'	Sugartyme White Crabapple	6	1.5-2" Cal	B&B
Ns	<i>Nyssa sylvatica</i>	Black Tupelo	1	4" Cal	B&B
Qp	<i>Quercus palustris</i> 'Green Pillar'	Green Pillar Pin Oak	7	2.5-3" Cal	B&B
Th	<i>Thuja plicata</i> 'Green Giant'	Green Giant Arborvitae	3	2.5-3" Cal	B&B
Ua	<i>Ulmus americana</i> 'Princeton'	Princeton American Elm	6	2.5-3" Cal	B&B

Lawn Penninton Smartseed Tall Fescue Blend
Seed Mix 1 New England Wetland Plants, Inc. New England Conservation/Wildlife Mix

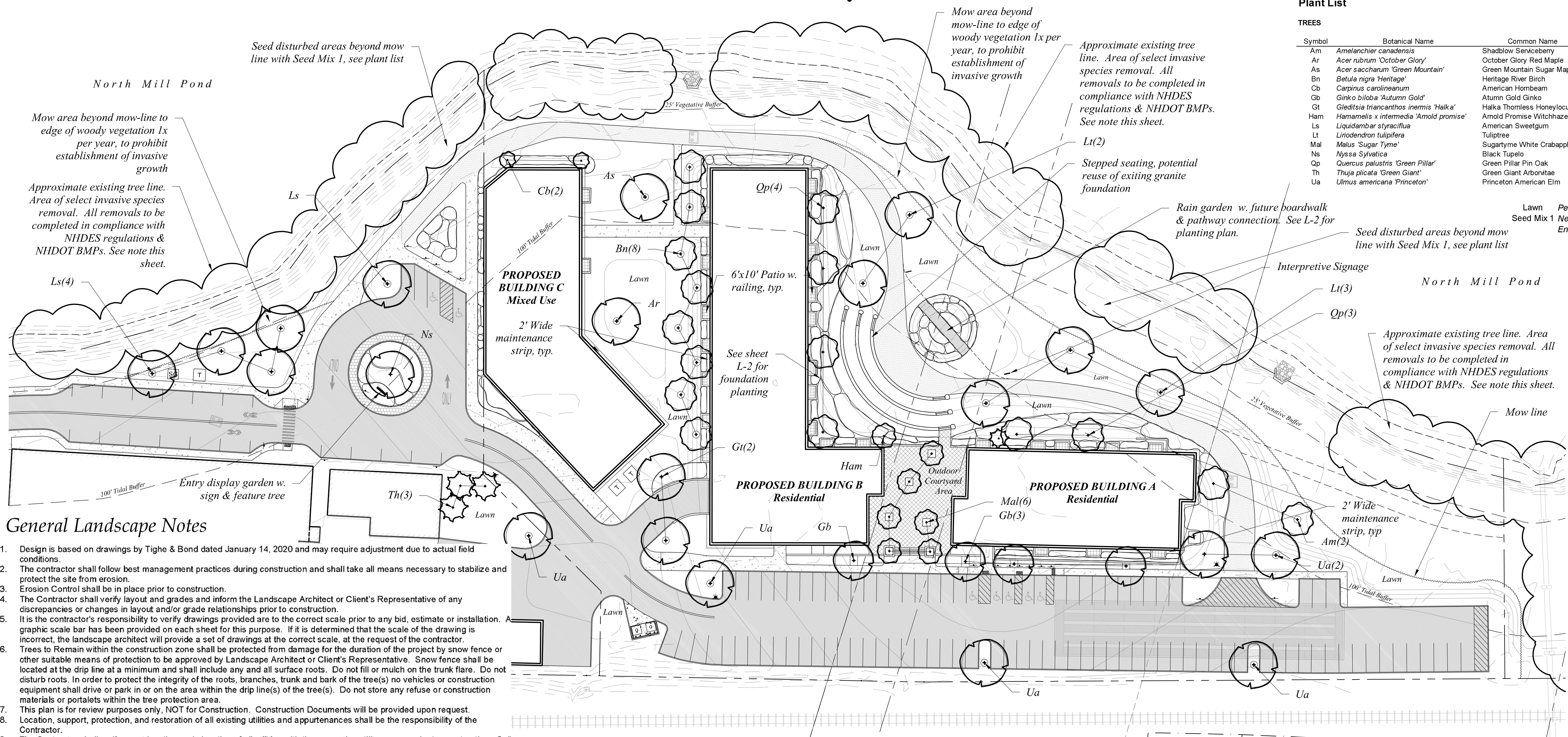

General Landscape Notes

- Design is based on drawings by Tighe & Bond dated January 14, 2020 and may require adjustment due to actual field conditions.
- The contractor shall follow best management practices during construction and shall take all means necessary to stabilize and protect the site from erosion.
- Erosion Control shall be in place prior to construction.
- The Contractor shall verify layout and grades and inform the Landscape Architect or Client's Representative of any discrepancies or changes in layout and/or grade relationships prior to construction.
- It is the contractor's responsibility to verify drawings provided are to the correct scale prior to any bid, estimate or installation. A graphic scale bar has been provided on each sheet for this purpose. If it is determined that the scale of the drawing is incorrect, the landscape architect will provide a set of drawings at the correct scale, at the request of the contractor.
- Trees to Remain within the construction zone shall be protected from damage for the duration of the project by snow fence or other suitable means of protection to be approved by Landscape Architect or Client's Representative. Snow fence shall be located at the drip line at a minimum and shall include any and all surface roots. Do not fill or mulch on the trunk flare. Do not disturb roots. In order to protect the integrity of the roots, trunk and bark of the tree(s) no vehicles or construction equipment shall drive or park in or on the area within the drip line(s) of the tree(s). Do not store any refuse or construction materials or portalets within the tree protection area.
- This plan is for review purposes only, NOT for Construction. Construction Documents will be provided upon request.
- Location, support, protection, and restoration of all existing utilities and appurtenances shall be the responsibility of the Contractor.
- The Contractor shall verify exact location and elevation of all utilities with the respective utility owners prior to construction. Call DIGSAFE at 1-888-344-7233.
- The Contractor shall procure any required permits prior to construction.
- Prior to any landscape construction activities Contractor shall test all existing loam and loam from off-site intended to be used for lawns and plant beds using a thorough sampling throughout the supply. Soil testing shall indicate levels of pH, nitrates, macro and micro nutrients, texture, soluble salts, and organic matter. Contractor shall provide Landscape Architect with test results and recommendations from the testing facility along with soil amendment plans as necessary for the proposed plantings to thrive. All loam to be used on site shall be amended as approved by the Landscape Architect prior to placement.
- Contractor shall notify landscape architect or owner's representative immediately if at any point during demolition or construction a site condition is discovered which may negatively impact the completed project. This includes, but is not limited to, unforeseen drainage problems, unknown subsurface conditions, and discrepancies between the plan and the site. If a contractor is aware of a potential issue, and does not bring it to the attention of the landscape architect or owner's representative immediately, they may be responsible for the labor and materials associated with correcting the problem.
- The Contractor shall furnish and plant all plants shown on the drawings and listed thereon. All plants shall be nursery-grown under climatic conditions similar to those in the locality of the project. Plants shall conform to the botanical names and standards of size, culture, and quality for the highest grades and standards as adopted by the American Association of Nurserymen, Inc. in the American Standard of Nursery Stock, American Standards Institute, Inc. 230 Southern Building, Washington, D.C. 20005.
- A complete list of plants, including a schedule of sizes, quantities, and other requirements is shown on the drawings. In the event that quantity discrepancies or material omissions occur in the plant materials list, the planting plans shall govern.
- All plants shall be legibly tagged with proper botanical name.
- The Contractor shall guarantee all plants for not less than one year from time of acceptance.
- Owner or Owner's Representative will inspect plants upon delivery for conformity to Specification requirements. Such approval shall not affect the right of inspection and rejection during or after the progress of the work. The Owner reserves the right to inspect and/or select all trees at the place of growth and reserves the right to approve a representative sample of each type of shrub, herbaceous perennial, annual, and ground cover at the place of growth. Such sample will serve as a minimum standard for all plants of the same species used in this work.
- No substitutions of plants may be made without prior approval of the Owner or the Owner's Representative for any reason.
- All landscaping shall be provided with the following:
 - Outside hose attachments spaced a maximum of 150 feet apart, and
 - An underground irrigation system, or
 - A temporary irrigation system designed for a two-year period of plant establishment.
- If an automatic irrigation system is installed, all irrigation valve boxes shall be located within planting bed areas.
- The contractor is responsible for all plant material from the time their work commences until final acceptance. This includes but is not limited to maintaining all plants in good condition, the security of the plant material once delivered to the site, and watering of plants. Plants shall be appropriately watered prior to, during and after planting. It is the contractor's responsibility to provide clean water suitable for plant health from off site, should it not be available on site.
- All disturbed areas will be dressed with 6" of topsoil and planted as noted on the plans or seeded except plant beds. Plant beds shall be prepared to a depth of 12" with 75% loam and 25% compost.
- Trees, ground cover, and shrub beds shall be mulched to a depth of 2" with one-year-old, well-composted, shredded native bark not longer than 4" in length and 1/2" in width, free of woodchips and sawdust. Mulch for ferns and herbaceous perennials shall be no longer than 1" in length. Trees in lawn areas shall be mulched in a 5' diameter min. saucer. Color of mulch shall be black.
- In no case shall mulch touch the stem of a plant nor shall mulch ever be more than 3" thick total (including previously applied mulch) over the root ball of any plant.
- Secondary lateral branches of deciduous trees overhanging vehicular and pedestrian travel ways shall be pruned up to a height of 6' to allow clear and safe passage of vehicles and pedestrians under tree canopy. Within the sight distance triangles at vehicle intersections the canopies shall be raised to 8' min.
- Snow shall be stored a minimum of 5' from shrubs and trunks of trees.
- Landscape Architect is not responsible for the means and methods of the contractor.

City of Portsmouth Landscape Notes

- The property owner and all future property owners shall be responsible for the maintenance, repair and replacement of all required screening and landscape materials.
- All required plant materials shall be tended and maintained in a healthy growing condition, replaced when necessary, and kept free of refuse and debris. All required fences and walls shall be maintained in good repair.
- The property owner shall be responsible to remove and replace dead or diseased plant materials immediately with the same type, size and quantity of plant materials as originally installed, unless alternative plantings are requested, justified and approved by the Planning Board or Planning Director.

INVASIVES REMOVAL AND DISTURBANCES WITHIN THE BUFFER ZONE

With the exception of the Norway Maples in the 25' vegetated buffer, which are to remain, invasive species within the 100' shoreland setback will be removed. Invasive species within the 25' vegetated buffer will be flagged in field by the landscape architect or certified arborist to be removed. Invasive shrubs within the 25' vegetated buffer with caliper measuring greater than 3" such as Buckthorn and Autumn Olive will be flush cut repeatedly to kill the plant, leaving the stumps in place. Woody invasives smaller than 3" caliper shall be removed with hand tools. Areas of soil disturbance from such removals will be limited to the immediate root area surrounding each plant, dressed with loam, replanted with New England Wildlife and Conservation Seed Mix and stabilized with jute mesh staked in place. All other areas disturbed by headwalls and culverts shall be loamed, seeded with New England Wildlife and Conservation Seed Mix and stabilized with jute mesh.

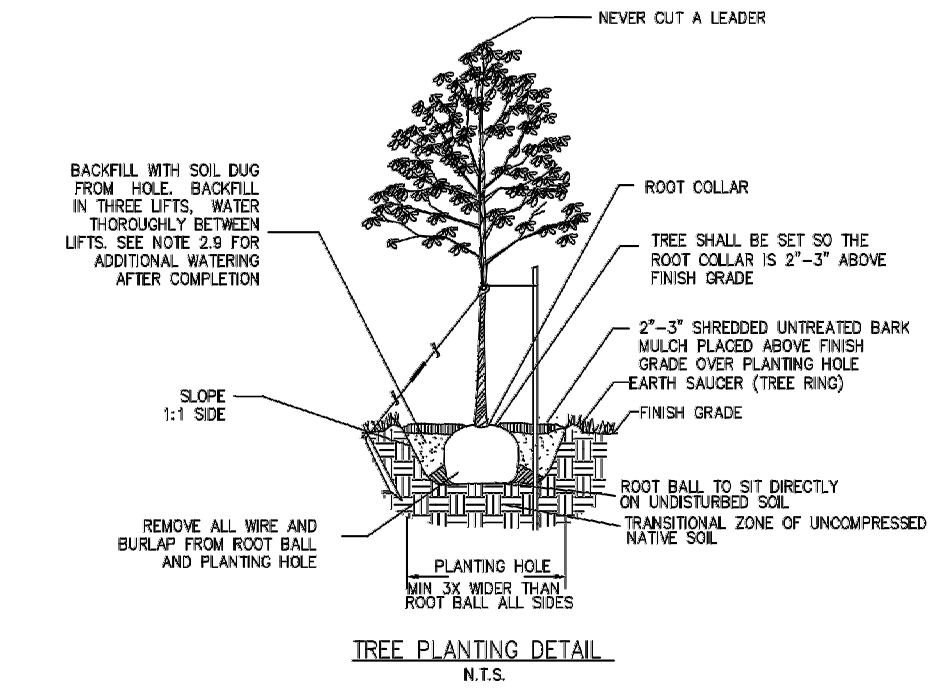

City of Portsmouth Tree Planting Detail

PART 1 - GENERAL

1.1 THE BASIS OF THE CITY OF PORTSMOUTH TREE PLANTING REQUIREMENTS IS THE ANSI A300 PART 6 STANDARD PRACTICES FOR PLANTING AND TRANSPORTING. ANSI A300 PART 6 LAYS OUT TERMS AND BASIC STANDARDS AS SET FORTH BY INDUSTRY BUT IT IS NOT THE "END ALL" FOR THE CITY OF PORTSMOUTH. THE FOLLOWING ARE THE CITY OF PORTSMOUTH, NH TREE PLANTING REQUIREMENTS THAT ARE IN ADDITION TO OR THAT GO BEYOND THE ANSI A300 PART 6.

PART 2 - EXECUTION

- ALL PLANTING HOLES SHALL BE DUG BY HAND - NO MACHINES. THE ONLY EXCEPTIONS ARE NEW CONSTRUCTION WHERE NEW PLANTING PITS, PLANTING BEDS WITH GRANITE CURBING, AND PLANTING SITES WITH SILVA CELLS ARE BEING CREATED. IF A MACHINE IS USED TO DIG IN ANY OF THESE SITUATIONS AND PLANTING DEPTH NEEDS TO BE RAISED THE MATERIAL IN THE BOTTOM OF THE PLANTING HOLE MUST BE FIRMED WITH MACHINE TO PREVENT SINKING OF THE ROOT BALL.
- ALL WIRE AND BURLAP SHALL BE REMOVED FROM THE ROOT BALL AND PLANTING HOLE.
- THE ROOT BALL OF THE TREE SHALL BE WORKED SO THAT THE ROOT COLLAR OF THE TREE IS VISIBLE AND NO GRIDLING ROOTS ARE PRESENT.
- THE ROOT COLLAR OF THE TREE SHALL BE 2"-3" ABOVE GRADE OF PLANTING HOLE FOR FINISHING DEPTH.
- ALL PLANTINGS SHALL BE BACKFILLED WITH SOIL FROM THE SITE AND AMENDED NO MORE THAN 20% WITH ORGANIC COMPOST. THE ONLY EXCEPTIONS ARE NEW CONSTRUCTION WHERE ENGINEERED SOIL IS BEING USED IN CONJUNCTION WITH SILVA CELLS AND WHERE NEW PLANTING BEDS ARE BEING CREATED.
- ALL PLANTINGS SHALL BE BACKFILLED IN THREE LIFTS AND ALL LIFTS SHALL BE WATERED SO THE PLANTING WILL BE SET AND FREE OF AIR POCKETS - NO EXCEPTIONS.
- AN EARTH BEEM SHALL BE PLACED AROUND THE PERIMETER OF THE PLANTING HOLE EXCEPT WHERE CURBED PLANTING BEDS OR PITS ARE BEING USED.
- 2"-3" OF MULCH SHALL BE PLACED OVER THE PLANTING AREA.
- AT THE TIME OF PLANTING IS COMPLETE THE PLANTING SHALL RECEIVE ADDITIONAL WATER TO ENSURE COMPLETE HYDRATION OF THE ROOTS, BACKFILL MATERIAL AND MULCH LAYER.
- STAKES AND GUY'S SHALL BE USED WHERE APPROPRIATE AND/OR NECESSARY. GUY MATERIAL SHALL BE NON-DAMAGING TO THE TREE.
- ALL PLANTING STOCK SHALL BE SPECIMEN QUALITY, FREE OF DEFECTS, AND DISEASE OR INJURY. THE CITY OF PORTSMOUTH, NH RESERVES THE RIGHT TO REFUSE/REJECT ANY PLANT MATERIAL OR PLANTING ACTION THAT FAILS TO MEET THE STANDARDS SET FORTH IN THE ANSI A300 PART 6 STANDARD PRACTICES FOR PLANTING AND TRANSPORTATION AND/OR THE CITY OF PORTSMOUTH, NH PLANTING REQUIREMENTS.

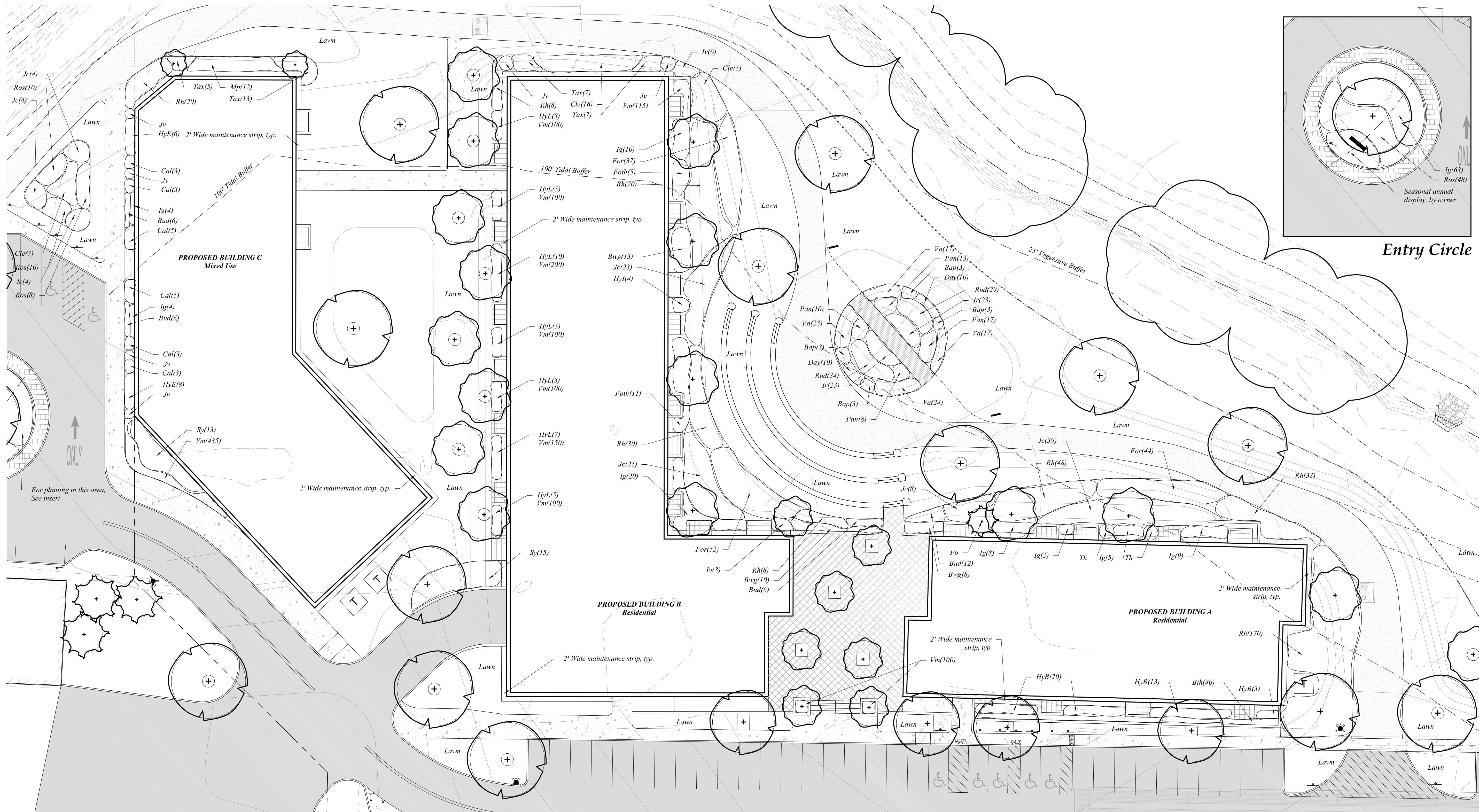

NOTE: For tree planting plan, see L-1

SHRUBS

Symbol	Botanical Name	Common Name	Quantity	Size	Comments
Bth	<i>Buxus 'Tide Hill'</i>	Tide Hill Boxwood	40	2' Ht	B&B
Bud	<i>Buddleia 'Lo and Behold'</i>	Lo and Behold Butterflybush	30	3 gal	
Bwg	<i>Buxus 'Winter Gem'</i>	Winter Gem Boxwood	31	2' Ht	B&B
Cle	<i>Clethra alnifolia 'Hummingbird'</i>	Hummingbird Summersweet	28	5 gal	
For	<i>Forsythia 'Gold Tide'</i>	Gold Tide Forsythia	177	3 gal	
Foth	<i>Fothergilla gardenii</i>	Dwarf Fothergilla	16	5 gal	
HyB	<i>Hydrangea paniculata 'Bobo'</i>	Bobo Hydrangea	36	3 gal	
HyE	<i>Hydrangea macrophylla 'Endless Summer'</i>	Endless Summer Hydrangea	14	5 gal	
HyI	<i>Hydrangea arborescens 'Incrediball'</i>	Incrediball Hydrangea	4	5 gal	
HyL	<i>Hydrangea paniculata 'Little Lime'</i>	Little Lime Hydrangea	42	3 gal	
Ig	<i>Ilex glabra 'Shamrock'</i>	Shamrock Inkberry	125	5 gal	full to ground
Iv	<i>Ilex verticillata 'Red Sprite'</i>	Red Sprite Winterberry	9	3 gal	
Jc	<i>Juniperus chinensis 'Sargentii'</i>	Sargent Juniper	107	5 gal	
Jv	<i>Juniperus virginiana 'Emerald Sentinel'</i>	Emerald Sentinel Red Cedar	6	7-8' Ht	B&B
Mp	<i>Myrica pensylvanica</i>	Northern Bayberry	12	5 gal	
Po	<i>Picea orientalis 'Gowdy'</i>	Gowdy Oriental Spruce	1	8-10' Ht	B&B
Rh	<i>Rhus aromatica 'Grow-Low'</i>	Grow Low Sumac	387	3 gal	
Ros	<i>Rosa 'Blush Knockout'</i>	Blush Knockout Rose	76	3 gal	
Sy	<i>Syringa meyeri 'Palibin'</i>	Dwarf Korean Lilac	28	3-4' Ht	B&B
Tax	<i>Taxus media 'Ever-Low'</i>	Ever-Low Yew	32	3 gal	
Th	<i>Thuja occidentalis 'Smaragd'</i>	Emerald Green Arborvitae	2	7-8' Ht	B&B

PERENNIALS, GROUNDCOVERS, VINES and ANNUALS

Symbol	Botanical Name	Common Name	Quantity	Size
Bap	<i>Baptisia australis</i>	False Blue Indigo	12	1 gal
Cal	<i>Calamagrostis acutifolia 'Karl Foerster'</i>	Feather Reed Grass	22	1 gal
Day	<i>Helianthus 'Big Time Happy'</i>	Big Time Happy Daylily	20	1 gal
Ir	<i>Iris versicolor</i>	Blue Flag Iris	46	1 gal
Pan	<i>Panicum virgatum 'Heavy Metal'</i>	Heavy Metal Switch Grass	48	1 gal
Rud	<i>Rubbeckia fulgida 'Goldsturm'</i>	Black-Eyed Susan	63	1 gal
Vm	<i>Vinca minor 'Bowles'</i>	Bowles Periwinkle	1500	2.5" pots

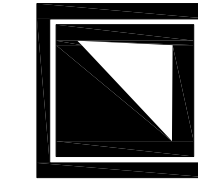
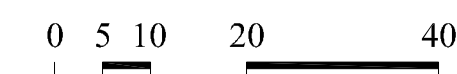

woodburn & company
 LANDSCAPE ARCHITECTURE
 103 Kent Place, New Hampshire
 Phone: 603.659.5949

Proposed Multi-Family Development
FOUNDATION PLANTING PLAN
 105 Bartlett Street Portsmouth, New Hampshire

Drawn By: VM
 Checked By: RW
 Scale: 1" = 20' - 0"
 Date: November 4, 2020
 Revisions:
 November 18, 2020
 January 20, 2021

L-2
 Sheet 2 of 2



1 SOUTH ELEVATION - RAILROAD TRACKS



2 EAST ELEVATION - BUILDING A

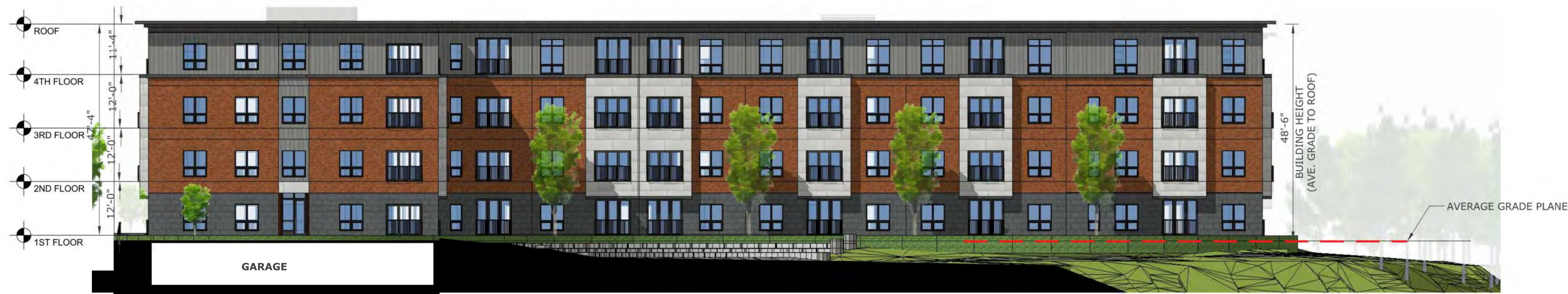

3 EAST ELEVATION - BUILDING B



4 EAST ELEVATION - BUILDING C

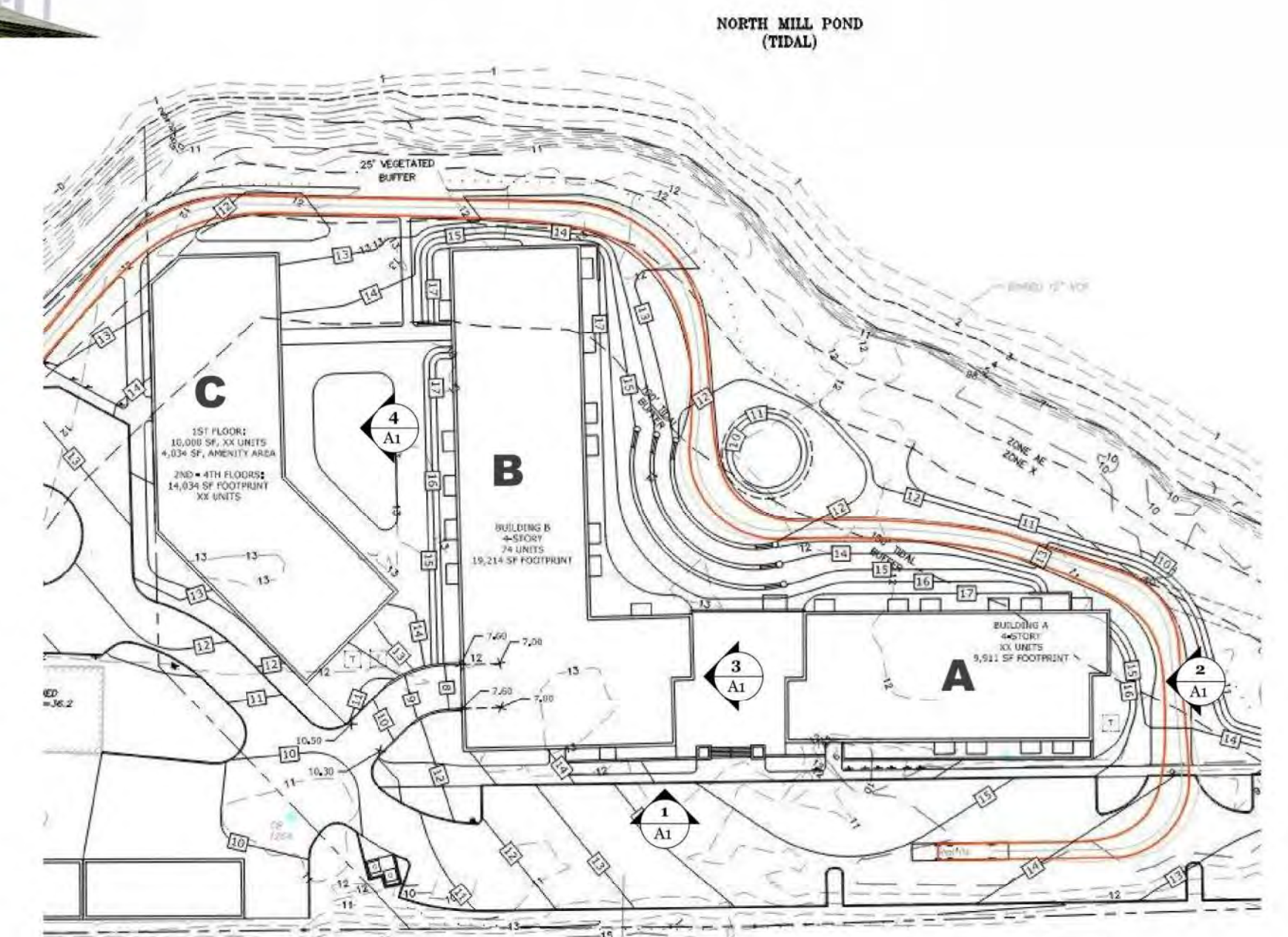

KEY PLAN





1 NORTH ELEVATION - NORTH MILL POND



2 WEST ELEVATION - BUILDING C



3 WEST ELEVATION - BUILDING B

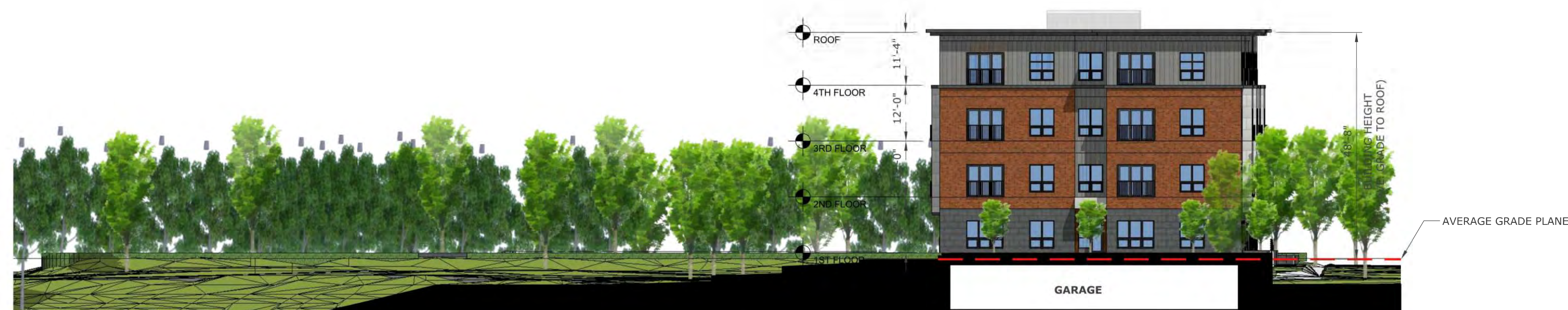

4 WEST ELEVATION - BUILDING A

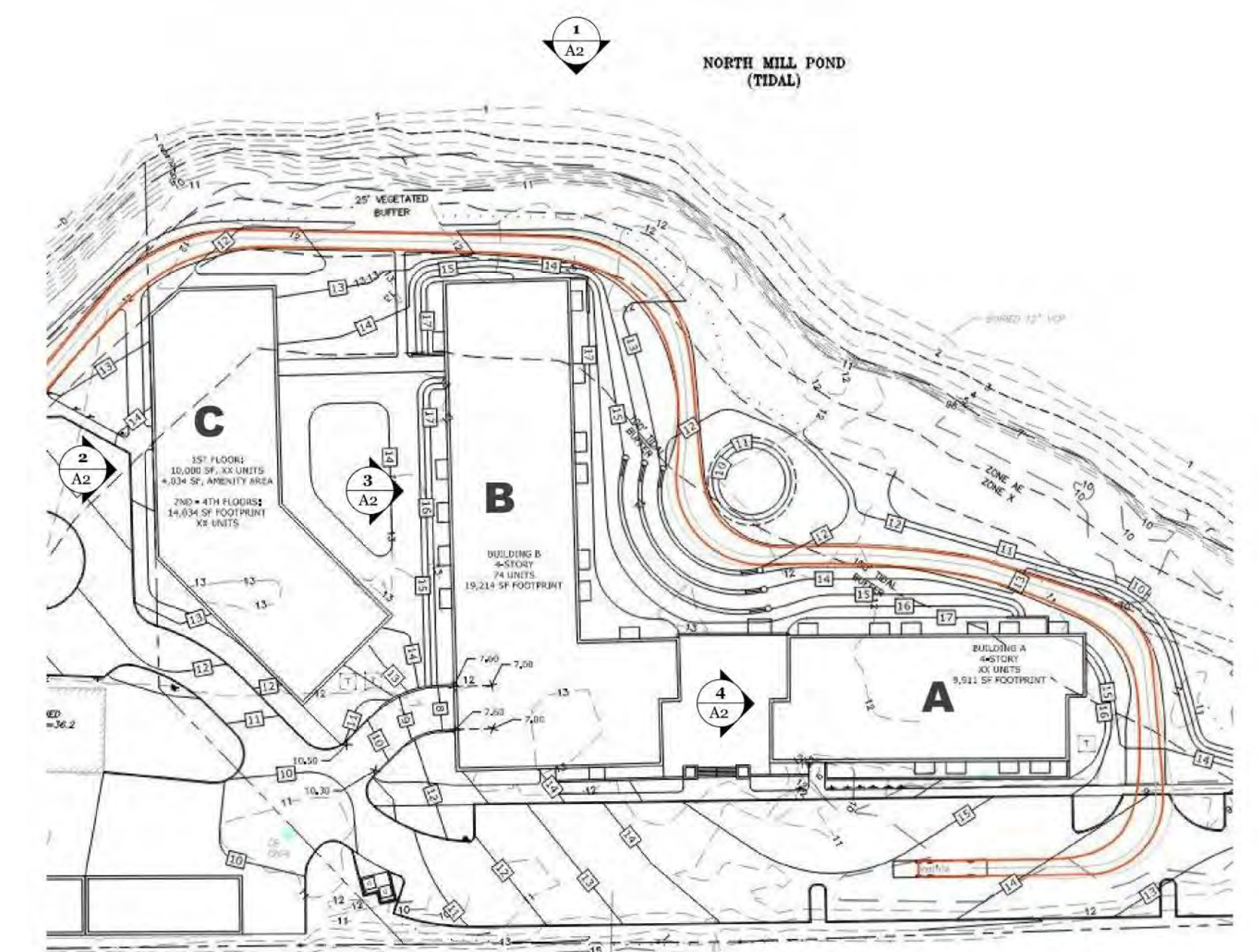

KEY PLAN

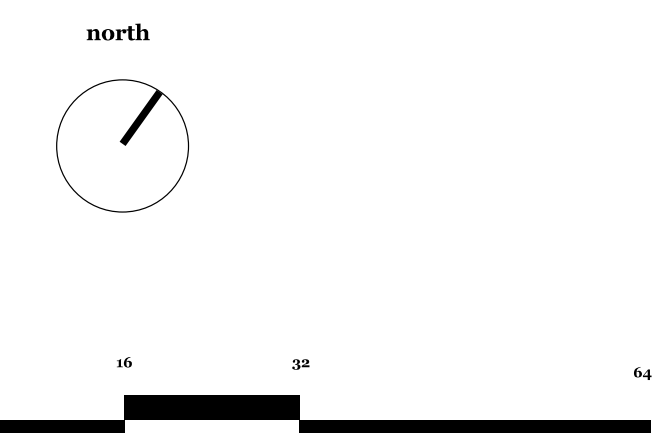



1 SOUTH ELEVATION - BUILDING B - RAILROAD TRACKS



2 WEST ELEVATION - BUILDING A

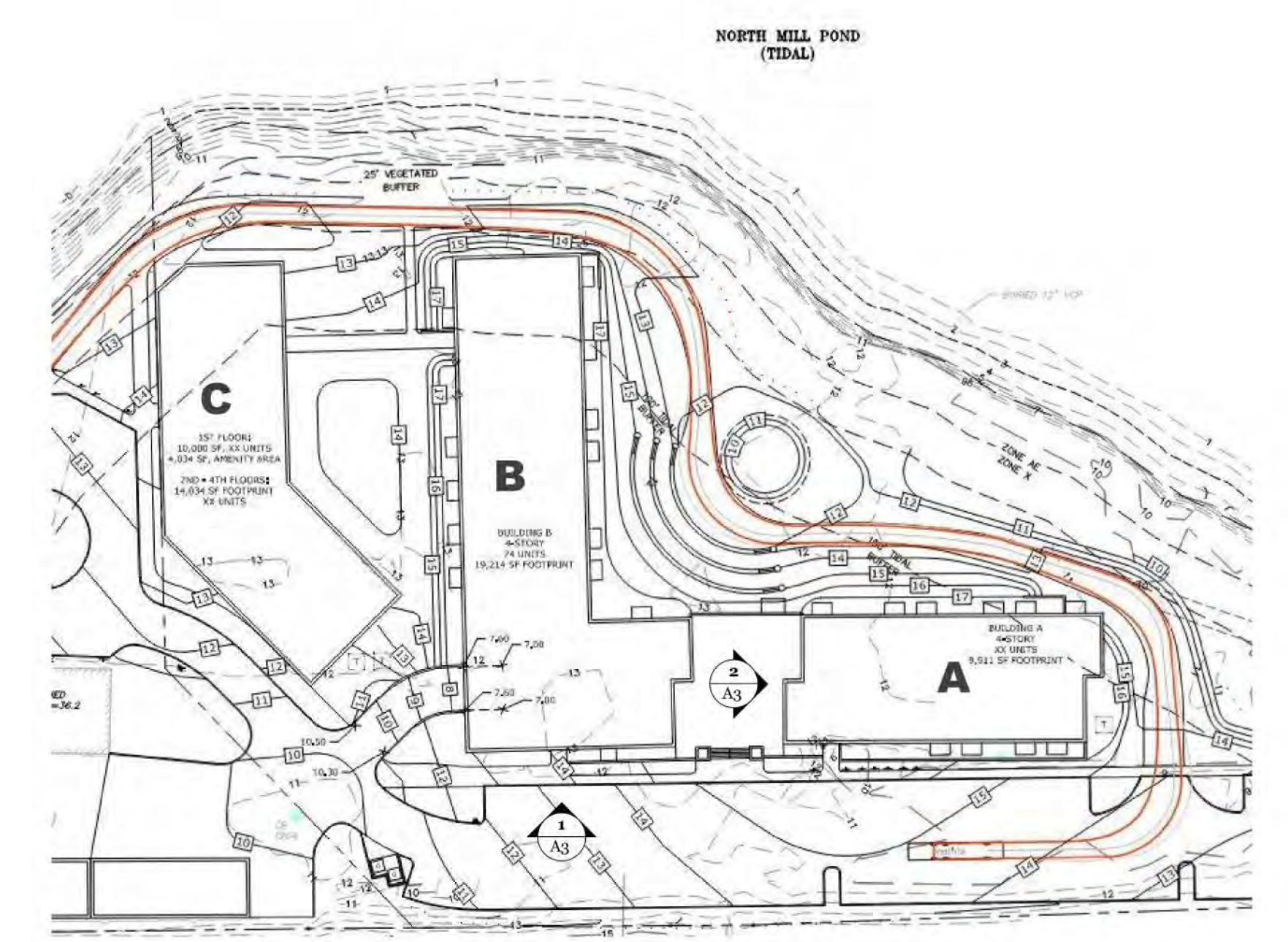

KEY PLAN

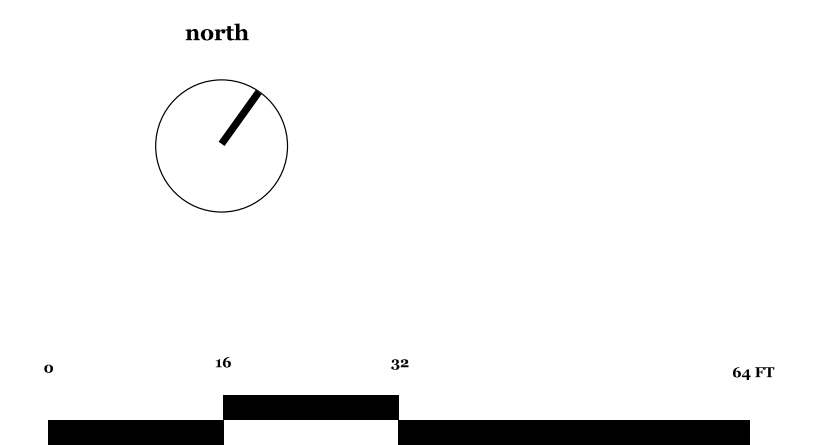

City of Portsmouth TAC, February 02, 2021:			
	TAC Stipulation	Applicant Response	Sheet
TAC Stipulations Prior to PB Review:			
1	Applicant shall submit a plan of Bartlett Street in the area where the extra water main is being eliminated, for review and approval by DPW. The plan shall delineate the existing water connections and note those proposed for elimination.	The applicant has prepared a plan which has been reviewed by the DPW. The applicant agrees to pay a fair share contribution towards the work shown on the Bartlett St Water Main Abandonment Plan.	Bartlett St Water Main Abandonment Plan
2	A note shall be added to the plan and Engineer shall confirm that porous pavement will be able to support design load of fire truck if required.	A note has been added to the porous asphalt detail. The porous asphalt mix specified is recommended by the UNH Stormwater Center for sites anticipating H-20 loading.	C-504
3	Change note for the telephone manhole at Bartlett Street to say 'alter the manhole structure as necessary to construct tip down. The same note will be required for the City's drainage manhole on the edge of the existing driveway.	The callout for the telephone manhole has been added as stated on the Utility Plan. The callout for the City's drain manhole has been revised to state the manhole frame and covers shall be adjusted as necessary to construct curb and to meet finished grade.	C-104.1 & C-103.1
4	Plans shall note that the sleeve under the RR will likely need to be replaced, to be verified by the water capacity analysis.	Callout has been revised to state that a new waterline sleeve be constructed under the railroad. Sizing for the sleeve will be determined by the railroad.	C-104.2
5	Placement and design of the Loading zone needs to be updated in coordination with DPW and the Fire Department per comments provided at the meeting.	The loading zone has been relocated to the cul-de-sac in front of Building C. The revised alignment has been reviewed and approved by DPW and the Fire Department.	C-102.2
6	Update plans to comply with ADA standards for provision of accessible parking spaces per guidance provided by City's Transportation and Parking Engineer.	The placement and total number of ADA parking spaces has been revised per the guidance provided by City's Transportation and Parking Engineer. A total of 9 ADA parking spaces are now provided including 1 in the cul-de-sac, 4 in the surface parking lot and 4 in the basement parking lot.	C-102.2 & C-102.3
7	Bicycle Route guide sign should be posted at the beginning of the multi-use path to indicate to cyclists that this is the point to enter the path, rather than continuing into the site parking lots. Likewise an END BIKE ROUTE sign should be placed in the same area facing the opposite direction.	Bicycle route guide sign and end sign have been added to the plans in the areas requested. Sign details have been added to the Sign Legend detail.	C-102.2 & C-504
8	A double yellow center line should be added to the area above the 4 parallel parking spaces to the south of the circular drop off area, to reinforce that there is two way traffic flow in this section.	A double yellow center line has been added to the area above the 4 parallel parking spaces to the south of the circular drop off area	C-102.2
9	Applicant to provide the trash management program for review.	A trash management letter has been provided.	N/A
10	Sharrow pavement markings should be thermoplastic, not paint.	Sharrow pavement marking detail has been revised to be thermoplastic, not paint.	C-504
11	Plans shall be updated to note fence or other security measures planned for the lumberyard area on the plan.	Plans have been revised to have a fence with a sliding gate at the rear entrance to the lumberyard	C-102.2
12	The truck turning template shall include a legend to more clearly delineate the template lines and what they signify.	The truck turning template has been revised to include a legend and callouts to more clearly delineate the template lines and what they signify.	Truck Turning Exhibit
13	The detail for PDMH9 on Sheet C-506 shall be updated to the satisfaction of DPW.	A trash grate has been added to the outlet structure detail PDMH9, as requested by DPW	C-506
14	The plan should note either signage or pavement markings that signify fire and emergency access locations on the trail.	Pavement markings to signify fire and emergency access locations on the trail have been added to the plans and details.	C-102.2 & C-504
15	The lighting plans and details shall updated to include screening of light trespass onto abutting properties, as necessary.	Lighting plans have been revised to include a type IV distribution for the parking lot fixtures in order to cutoff back light trespass onto abutting properties.	C-105
16	The plans shall be updated to reflect that the applicant shall either complete the greenway trail connection to the lot line on the northeast side of the lot as part of this project or the applicant shall agree to contribute a fee for the design, permitting and construction of the trail to be completed by the City in the future.	The plans have been revised to reflect that the applicant will complete the greenway trail connection to the lot line on the northeast wide of the lot as part of this project.	C-102.2 & C-103.2

City of Portsmouth CC, February 10, 2021:			
	<u>CC Stipulation</u>	<u>Applicant Response</u>	<u>Sheet</u>
CC Stipulations:			
1	That the bike/ped path be porous pavement and include an operation and maintenance plan which includes no salting or sanding.	A section on porous pavement has been added to the operations and maintenance section of the drainage report, including the requirement of no sanding or salting.	Drainage Analysis, Section 6
2	That the site use only dark sky friendly lighting.	Lighting plans have been revised to include a type IV distribution for the parking lot fixtures in order to cutoff back light trespass onto abutting properties.	N/A



City of Portsmouth, New Hampshire

Site Plan Application Checklist

This site plan application checklist is a tool designed to assist the applicant in the planning process and for preparing the application for Planning Board review. The checklist is required to be completed and uploaded to the Site Plan application in the City's online permitting system. A pre-application conference with a member of the planning department is strongly encouraged as additional project information may be required depending on the size and scope. The applicant is cautioned that this checklist is only a guide and is not intended to be a complete list of all site plan review requirements. Please refer to the Site Plan review regulations for full details.

Applicant Responsibilities (Section 2.5.2): Applicable fees are due upon application submittal along with required attachments. The application shall be complete as submitted and provide adequate information for evaluation of the proposed site development. Waiver requests must be submitted in writing with appropriate justification.

Name of Applicant: Iron Horse Properties, LLC Date Submitted: March 10, 2021

Application # (in City's online permitting): LU 20-4

Site Address: 105 Bartlett Street Map: 157 Lot: 1

Application Requirements			
<input checked="" type="checkbox"/>	Required Items for Submittal	Item Location (e.g. Page or Plan Sheet/Note #)	Waiver Requested
<input checked="" type="checkbox"/>	Complete application form submitted via the City's web-based permitting program (2.5.2.1(2.5.2.3A))	Enclosed	N/A
<input checked="" type="checkbox"/>	All application documents, plans, supporting documentation and other materials uploaded to the application form in viewpoint in digital Portable Document Format (PDF). One hard copy of all plans and materials shall be submitted to the Planning Department by the published deadline. (2.5.2.8)	Enclosed	N/A

Site Plan Review Application Required Information			
<input checked="" type="checkbox"/>	Required Items for Submittal	Item Location (e.g. Page/line or Plan Sheet/Note #)	Waiver Requested
<input checked="" type="checkbox"/>	Statement that lists and describes "green" building components and systems. (2.5.3.1B)	Enclosed	
<input checked="" type="checkbox"/>	Existing and proposed gross floor area and dimensions of all buildings and statement of uses and floor area for each floor. (2.5.3.1C)	Site Plan Sheet C-102.2	N/A
<input checked="" type="checkbox"/>	Tax map and lot number, and current zoning of all parcels under Site Plan Review. (2.5.3.1D)	Site Plan Sheet C-102	N/A

Site Plan Review Application Required Information			
<input checked="" type="checkbox"/>	Required Items for Submittal	Item Location (e.g. Page/line or Plan Sheet/Note #)	Waiver Requested
<input checked="" type="checkbox"/>	Owner's name, address, telephone number, and signature. Name, address, and telephone number of applicant if different from owner. (2.5.3.1E)	Enclosed Existing Conditions Plan Sheet C-101	N/A
<input checked="" type="checkbox"/>	Names and addresses (including Tax Map and Lot number and zoning districts) of all direct abutting property owners (including properties located across abutting streets) and holders of existing conservation, preservation or agricultural preservation restrictions affecting the subject property. (2.5.3.1F)	Subdivision Plans Sheet 1 of 5 to Sheet 5 of 5	N/A
<input checked="" type="checkbox"/>	Names, addresses and telephone numbers of all professionals involved in the site plan design. (2.5.3.1G)	Cover Sheet	N/A
<input checked="" type="checkbox"/>	List of reference plans. (2.5.3.1H)	Existing Conditions Plan Sheet C-101	N/A
<input checked="" type="checkbox"/>	List of names and contact information of all public or private utilities servicing the site. (2.5.3.1I)	Utilities Plan Sheets C-104.1 & C-104.2	N/A

Site Plan Specifications			
<input checked="" type="checkbox"/>	Required Items for Submittal	Item Location (e.g. Page/line or Plan Sheet/Note #)	Waiver Requested
<input checked="" type="checkbox"/>	Full size plans shall not be larger than 22 inches by 34 inches with match lines as required, unless approved by the Planning Director.. (2.5.4.1A)	Required on all plan sheets	N/A
<input checked="" type="checkbox"/>	Scale: Not less than 1 inch = 60 feet and a graphic bar scale shall be included on all plans. (2.5.4.1B)	Required on all plan sheets	N/A
<input checked="" type="checkbox"/>	GIS data should be referenced to the coordinate system New Hampshire State Plane, NAD83 (1996), with units in feet. (2.5.4.1C)	Existing Conditions Plan Sheet C-101	N/A
<input checked="" type="checkbox"/>	Plans shall be drawn to scale and stamped by a NH licensed civil engineer. (2.5.4.1D)	Required on all plan sheets	N/A
<input checked="" type="checkbox"/>	Wetlands shall be delineated by a NH certified wetlands scientist and so stamped. (2.5.4.1E)	Existing Conditions Plan Sheet C-101	N/A
<input checked="" type="checkbox"/>	Title (name of development project), north point, scale, legend. (2.5.4.2A)	Required on all plan sheets	N/A
<input checked="" type="checkbox"/>	Date plans first submitted, date and explanation of revisions. (2.5.4.2B)	Required on all plan sheets	N/A
<input checked="" type="checkbox"/>	Individual plan sheet title that clearly describes the information that is displayed. (2.5.4.2C)	Required on all plan sheets	N/A
<input checked="" type="checkbox"/>	Source and date of data displayed on the plan. (2.5.4.2D)	Required on all plan sheets	N/A

Site Plan Specifications – Required Exhibits and Data

<input checked="" type="checkbox"/>	Required Items for Submittal	Item Location (e.g. Page/line or Plan Sheet/Note #)	Waiver Requested
<input checked="" type="checkbox"/>	<p>1. Existing Conditions: (2.5.4.3A)</p> <ul style="list-style-type: none"> • Surveyed plan of site showing existing natural and built features; • Existing building footprints and gross floor area; • Existing parking areas and number of parking spaces provided; • Zoning district boundaries; • Existing, required, and proposed dimensional zoning requirements including building and open space coverage, yards and/or setbacks, and dwelling units per acre; • Existing impervious and disturbed areas; • Limits and type of existing vegetation; • Wetland delineation, wetland function and value assessment (including vernal pools); • SFHA, 100-year flood elevation line and BFE data, as required. 	Existing Conditions Plan Sheets C-101, C-101.1 & C-101.2	
<input checked="" type="checkbox"/>	<p>2. Buildings and Structures: (2.5.4.3B)</p> <ul style="list-style-type: none"> • Plan view: Use, size, dimensions, footings, overhangs, 1st fl. elevation; • Elevations: Height, massing, placement, materials, lighting, façade treatments; • Total Floor Area; • Number of Usable Floors; • Gross floor area by floor and use. 	Site Plan Sheets C-102, C-102.1 & C-102.2	
<input checked="" type="checkbox"/>	<p>3. Access and Circulation: (2.5.4.3C)</p> <ul style="list-style-type: none"> • Location/width of access ways within site; • Location of curbing, right of ways, edge of pavement and sidewalks; • Location, type, size and design of traffic signing (pavement markings); • Names/layout of existing abutting streets; • Driveway curb cuts for abutting prop. and public roads; • If subdivision; Names of all roads, right of way lines and easements noted; • AASHTO truck turning templates, description of minimum vehicle allowed being a WB-50 (unless otherwise approved by TAC). 	Site Plan Sheets C-102, C-102.1 & C-102.2	
<input checked="" type="checkbox"/>	<p>4. Parking and Loading: (2.5.4.3D)</p> <ul style="list-style-type: none"> • Location of off street parking/loading areas, landscaped areas/buffers; • Parking Calculations (# required and the # provided). 	Site Plan Sheets C-102, C-102.1 & C-102.2	
<input checked="" type="checkbox"/>	<p>5. Water Infrastructure: (2.5.4.3E)</p> <ul style="list-style-type: none"> • Size, type and location of water mains, shut-offs, hydrants & Engineering data; • Location of wells and monitoring wells (include protective radii). 	Utilities Plan Sheets C-104.1 & C-104.2	
<input checked="" type="checkbox"/>	<p>6. Sewer Infrastructure: (2.5.4.3F)</p> <ul style="list-style-type: none"> • Size, type and location of sanitary sewage facilities & Engineering data, including any onsite temporary facilities during construction period. 	Utilities Plan Sheets C-104.1 & C-104.2	

<input checked="" type="checkbox"/>	7. Utilities: (2.5.4.3G) <ul style="list-style-type: none"> The size, type and location of all above & below ground utilities; Size type and location of generator pads, transformers and other fixtures. 	Utilities Plan Sheets C-104.1 & C-104.2	
<input checked="" type="checkbox"/>	8. Solid Waste Facilities: (2.5.4.3H) <ul style="list-style-type: none"> The size, type and location of solid waste facilities. 	Site Plan Sheet C-102.2	
<input checked="" type="checkbox"/>	9. Storm water Management: (2.5.4.3I) <ul style="list-style-type: none"> The location, elevation and layout of all storm-water drainage. The location of onsite snow storage areas and/or proposed off-site snow removal provisions. Location and containment measures for any salt storage facilities Location of proposed temporary and permanent material storage locations and distance from wetlands, water bodies, and stormwater structures. 	Grading and Drainage Plan Sheets C-103.1 & C-103.2	
<input checked="" type="checkbox"/>	10. Outdoor Lighting: (2.5.4.3J) <ul style="list-style-type: none"> Type and placement of all lighting (exterior of building, parking lot and any other areas of the site) and photometric plan. 	Photometrics Plan Sheets C-105.1 & C-105.2	
<input checked="" type="checkbox"/>	11. Indicate where dark sky friendly lighting measures have been implemented. (10.1)	Photometrics Plan Sheets C-105.1 & C-105.2	
<input checked="" type="checkbox"/>	12. Landscaping: (2.5.4.3K) <ul style="list-style-type: none"> Identify all undisturbed area, existing vegetation and that which is to be retained; Location of any irrigation system and water source. 	Landscaping Plan Sheets L-1 & L-2	
<input checked="" type="checkbox"/>	13. Contours and Elevation: (2.5.4.3L) <ul style="list-style-type: none"> Existing/Proposed contours (2 foot minimum) and finished grade elevations. 	Grading and Drainage Plan Sheets C-103.1 & C-103.2	
<input checked="" type="checkbox"/>	14. Open Space: (2.5.4.3M) <ul style="list-style-type: none"> Type, extent and location of all existing/proposed open space. 	Site Plan Sheet C-102 & Open Space Exhibit	
<input checked="" type="checkbox"/>	15. All easements, deed restrictions and non-public rights of ways. (2.5.4.3N)	Subdivision Plans Sheet 1 of 5 to Sheet 5 of 5	
<input checked="" type="checkbox"/>	16. Character/Civic District (All following information shall be included): (2.5.4.3P) <ul style="list-style-type: none"> Applicable Building Height (10.5A21.20 & 10.5A43.30); Applicable Special Requirements (10.5A21.30); Proposed building form/type (10.5A43); Proposed community space (10.5A46). 	Site Plan Sheet C-102	
<input checked="" type="checkbox"/>	17. Special Flood Hazard Areas (2.5.4.3Q) <ul style="list-style-type: none"> The proposed development is consistent with the need to minimize flood damage; All public utilities and facilities are located and construction to minimize or eliminate flood damage; Adequate drainage is provided so as to reduce exposure to flood hazards. 	N/A	

Other Required Information			
<input checked="" type="checkbox"/>	Required Items for Submittal	Item Location (e.g. Page/line or Plan Sheet/Note #)	Waiver Requested
<input checked="" type="checkbox"/>	Traffic Impact Study or Trip Generation Report, as required. (3.2.1-2)	Enclosed	
<input checked="" type="checkbox"/>	Indicate where Low Impact Development Design practices have been incorporated. (7.1)	Grading and Drainage Plan Sheets C-103.1 & C-103.2	
<input checked="" type="checkbox"/>	Indicate whether the proposed development is located in a wellhead protection or aquifer protection area. Such determination shall be approved by the Director of the Dept. of Public Works. (7.3.1)	N/A	
<input checked="" type="checkbox"/>	Stormwater Management and Erosion Control Plan. (7.4)	Enclosed	
<input checked="" type="checkbox"/>	Inspection and Maintenance Plan (7.6.5)	Enclosed	

Final Site Plan Approval Required Information			
<input checked="" type="checkbox"/>	Required Items for Submittal	Item Location (e.g. Page/line or Plan Sheet/Note #)	Waiver Requested
<input checked="" type="checkbox"/>	All local approvals, permits, easements and licenses required, including but not limited to: <ul style="list-style-type: none"> • Waivers; • Driveway permits; • Special exceptions; • Variances granted; • Easements; • Licenses. (2.5.3.2A)	Cover Sheet	
<input checked="" type="checkbox"/>	Exhibits, data, reports or studies that may have been required as part of the approval process, including but not limited to: <ul style="list-style-type: none"> • Calculations relating to stormwater runoff; • Information on composition and quantity of water demand and wastewater generated; • Information on air, water or land pollutants to be discharged, including standards, quantity, treatment and/or controls; • Estimates of traffic generation and counts pre- and post-construction; • Estimates of noise generation; • A Stormwater Management and Erosion Control Plan; • Endangered species and archaeological / historical studies; • Wetland and water body (coastal and inland) delineations; • Environmental impact studies. (2.5.3.2B)	Enclosed	
<input checked="" type="checkbox"/>	A document from each of the required private utility service providers indicating approval of the proposed site plan and indicating an ability to provide all required private utilities to the site. (2.5.3.2D)	Enclosed	

Final Site Plan Approval Required Information

<input checked="" type="checkbox"/>	Required Items for Submittal	Item Location (e.g. Page/line or Plan Sheet/Note #)	Waiver Requested
<input checked="" type="checkbox"/>	A list of any required state and federal permit applications required for the project and the status of same. (2.5.3.2E)	Cover Sheet	
<input checked="" type="checkbox"/>	A note shall be provided on the Site Plan stating: "All conditions on this Plan shall remain in effect in perpetuity pursuant to the requirements of the Site Plan Review Regulations." (2.5.4.2E)	Site Plan Sheets C-102.1 & C-102.2	N/A
<input checked="" type="checkbox"/>	For site plans that involve land designated as "Special Flood Hazard Areas" (SFHA) by the National Flood Insurance Program (NFIP) confirmation that all necessary permits have been received from those governmental agencies from which approval is required by Federal or State law, including Section 404 of the Federal Water Pollution Control Act Amendments of 1972, 33 U.S.C. 1334. (2.5.4.2F)	N/A	
<input checked="" type="checkbox"/>	Plan sheets submitted for recording shall include the following notes: a. "This Site Plan shall be recorded in the Rockingham County Registry of Deeds." b. "All improvements shown on this Site Plan shall be constructed and maintained in accordance with the Plan by the property owner and all future property owners. No changes shall be made to this Site Plan without the express approval of the Portsmouth Planning Director." (2.13.3)	Site Plan Sheets C-102.1 & C-102.2	N/A

Applicant's Signature:  Date: 3/10/21



City of Portsmouth, New Hampshire

Subdivision Application Checklist

This subdivision application checklist is a tool designed to assist the applicant in the planning process and for preparing the application for Planning Board review. A pre-application conference with a member of the planning department is strongly encouraged as additional project information may be required depending on the size and scope. The applicant is cautioned that this checklist is only a guide and is not intended to be a complete list of all subdivision review requirements. Please refer to the Subdivision review regulations for full details.

Applicant Responsibilities (Section III.C): Applicable fees are due upon application submittal along with the Preliminary or final plat and supporting documents and studies submitted in PDF format with the [online application](#). Please consult with Planning staff for submittal requirements.

Iron Horse Properties, LLC, Clipper Traders LLC,
 Owner: Portsmouth Hardware & Lumber, LLC Date Submitted: March 10, 2021

Applicant: Iron Horse Properties, LLC

Phone Number: 617-742-6000 E-mail: jeffj@cathartes.com

Site Address 1: 105 Bartlett Street Map: 157 Lot: 1

Site Address 2: _____ Map: _____ Lot: _____

Application Requirements			
<input checked="" type="checkbox"/>	Required Items for Submittal	Item Location (e.g. Page or Plan Sheet/Note #)	Waiver Requested
<input checked="" type="checkbox"/>	Completed Application form submitted via View Point (the City's web-based permitting program). (III.C.2-3)	Enclosed	N/A
<input checked="" type="checkbox"/>	All application documents, plans, supporting documentation and other materials uploaded to the application form in View Point in digital Portable Document Format (PDF). One hard copy of all plans and materials shall be submitted to the Planning Department by the published deadline. (III.C.4)	Enclosed	N/A

Requirements for Preliminary/Final Plat			
<input checked="" type="checkbox"/>	Required Items for Submittal	Item Location (e.g. Page/line or Plan Sheet/Note #)	Required for Preliminary / Final Plat
<input checked="" type="checkbox"/>	Name and address of record owner, any option holders, descriptive name of subdivision, engineer and/or surveyor or name of person who prepared the plat. (Section IV.1/V.1)	Cover Sheet Subdivision Plans Sheet 1 of 5 to Sheet 5 of 5	<input checked="" type="checkbox"/> Preliminary Plat <input checked="" type="checkbox"/> Final Plat

Requirements for Preliminary/Final Plat				
<input checked="" type="checkbox"/>	Required Items for Submittal	Item Location (e.g. Page/line or Plan Sheet/Note #)	Required for Preliminary / Final Plat	Waiver Requested
<input checked="" type="checkbox"/>	<p>Preliminary Plat Names and addresses of all adjoining property owners. (Section IV.2)</p> <p>Final Plat Names and addresses of all abutting property owners, locations of buildings within one hundred (100) feet of the parcel, and any new house numbers within the subdivision. (Section V.2)</p>	Subdivision Plans Sheet 1 of 5 to Sheet 5 of 5	<input checked="" type="checkbox"/> Preliminary Plat <input checked="" type="checkbox"/> Final Plat	N/A
<input checked="" type="checkbox"/>	North point, date, and bar scale. (Section IV.3/V3)	Required on all Plan Sheets	<input checked="" type="checkbox"/> Preliminary Plat <input checked="" type="checkbox"/> Final Plat	N/A
<input checked="" type="checkbox"/>	Zoning classification and minimum yard dimensions required. (Section IV.4/V.4)	Subdivision Plan Sheet 1 of 5	<input checked="" type="checkbox"/> Preliminary Plat <input checked="" type="checkbox"/> Final Plat	N/A
<input checked="" type="checkbox"/>	<p>Preliminary Plat Scale (not to be smaller than one hundred (100) feet = 1 inch) and location map (at a scale of 1" = 1000'). (Section IV.5)</p> <p>Final Plat Scale (not to be smaller than 1"=100'), Location map (at a scale of 1"=1,000') showing the property being subdivided and its relation to the surrounding area within a radius of 2,000 feet. Said location map shall delineate all streets and other major physical features that my either affect or be affected by the proposed development. (Section V.5)</p>	Subdivision Plans Sheet 1 of 5 to Sheet 5 of 5	<input checked="" type="checkbox"/> Preliminary Plat <input checked="" type="checkbox"/> Final Plat	N/A
<input checked="" type="checkbox"/>	Location and approximate dimensions of all existing and proposed property lines including the entire area proposed to be subdivided, the areas of proposed lots, and any adjacent parcels in the same ownership. (Section IV.6)	Subdivision Plans Sheet 1 of 5 to Sheet 5 of 5	<input checked="" type="checkbox"/> Preliminary Plat <input checked="" type="checkbox"/> Final Plat	
<input checked="" type="checkbox"/>	Dimensions and areas of all lots and any and all property to be dedicated or reserved for schools, parks, playgrounds, or other public purpose. Dimensions shall include radii and length of all arcs and calculated bearing for all straight lines. (Section V.6/ IV.7)	Subdivision Plans Sheet 1 of 5 to Sheet 5 of 5	<input checked="" type="checkbox"/> Preliminary Plat <input checked="" type="checkbox"/> Final Plat	N/A
<input checked="" type="checkbox"/>	Location, names, and present widths of all adjacent streets, with a designation as to whether public or private and approximate location of existing utilities to be used. Curbs and sidewalks shall be shown. (Section IV.8/V.7)	Subdivision Plans Sheet 1 of 5 to Sheet 5 of 5	<input checked="" type="checkbox"/> Preliminary Plat <input checked="" type="checkbox"/> Final Plat	

Requirements for Preliminary/Final Plat				
<input checked="" type="checkbox"/>	Required Items for Submittal	Item Location (e.g. Page/line or Plan Sheet/Note #)	Required for Preliminary / Final Plat	Waiver Requested
<input checked="" type="checkbox"/>	Location of significant physical features, including bodies of water, watercourses, wetlands, railroads, important vegetation, stone walls and soils types that may influence the design of the subdivision. (Section IV.9/V.8)	Subdivision Plans Sheet 1 of 5 to Sheet 5 of 5	<input checked="" type="checkbox"/> Preliminary Plat <input checked="" type="checkbox"/> Final Plat	
<input checked="" type="checkbox"/>	Preliminary Plat Proposed locations, widths and other dimensions of all new streets and utilities, including water mains, storm and sanitary sewer mains, catch basins and culverts, street lights, fire hydrants, sewerage pump stations, etc. (Section IV.10) Final Plat Proposed locations and profiles of all proposed streets and utilities, including water mains, storm and sanitary sewer mains, catchbasins and culverts, together with typical cross sections. Profiles shall be drawn to a horizontal scale of 1"=50' and a vertical scale of 1"=5', showing existing centerline grade, existing left and right sideline grades, and proposed centerline grade. (Section V.9)	Site Plan Sheets C-102, C-102.1 & C-102.2 Grading and Drainage Plan Sheets C-103.1 & C-103.2 Utilities Plan Sheets C-104.1 & C-104.2	<input checked="" type="checkbox"/> Preliminary Plat <input checked="" type="checkbox"/> Final Plat	
<input checked="" type="checkbox"/>	When required by the Board, the plat shall be accompanied by profiles of proposed street grades, including extensions for a reasonable distance beyond the subject land; also grades and sizes of proposed utilities. (Section IV.10)	Roadway Plan and Profile Sheets C-201.1 & C-201.2	<input checked="" type="checkbox"/> Preliminary Plat <input checked="" type="checkbox"/> Final Plat	
<input checked="" type="checkbox"/>	Base flood elevation (BFE) for subdivisions involving greater than five (5) acres or fifty (50) lots. (Section IV.11)	Subdivision Plans Sheet 1 of 5 to Sheet 5 of 5	<input checked="" type="checkbox"/> Preliminary Plat <input checked="" type="checkbox"/> Final Plat	
<input checked="" type="checkbox"/>	For subdivisions of five (5) lots or more, or at the discretion of the Board otherwise, the preliminary plat shall show contours at intervals no greater than two (2) feet. Contours shall be shown in dotted lines for existing natural surface and in solid lines for proposed final grade, together with the final grade elevations shown in figures at all lot corners. If existing grades are not to be changed, then the contours in these areas shall be solid lines. (Section IV.12/ V.12)	Existing Conditions Plan Sheets C-101, C-101.1 & C-101.2	<input checked="" type="checkbox"/> Preliminary Plat <input checked="" type="checkbox"/> Final Plat	

Requirements for Preliminary/Final Plat				
<input checked="" type="checkbox"/>	Required Items for Submittal	Item Location (e.g. Page/line or Plan Sheet/Note #)	Required for Preliminary / Final Plat	Waiver Requested
<input checked="" type="checkbox"/>	Dates and permit numbers of all necessary permits from governmental agencies from which approval is required by Federal or State law. (Section V.10)	Cover Sheet	<input type="checkbox"/> Preliminary Plat <input checked="" type="checkbox"/> Final Plat	
<input checked="" type="checkbox"/>	For subdivisions involving greater than five (5) acres or fifty (50) lots, the final plat shall show hazard zones and shall include elevation data for flood hazard zones. (Section V.11)	Subdivision Plans Sheet 1 of 5 to Sheet 5 of 5	<input type="checkbox"/> Preliminary Plat <input checked="" type="checkbox"/> Final Plat	
<input checked="" type="checkbox"/>	Location of all permanent monuments. (Section V.12)	Subdivision Plans Sheet 1 of 5 to Sheet 5 of 5	<input type="checkbox"/> Preliminary Plat <input checked="" type="checkbox"/> Final Plat	

<input checked="" type="checkbox"/>	14. Erosion and Sedimentation Control (VI.14)		
<input checked="" type="checkbox"/>	Required Items for Submittal	Item Location (e.g. Page/line or Plan Sheet/Note #)	Waiver Requested
<input checked="" type="checkbox"/>	15. Easements (VI.15)	Easement Plans C-301.1, C-301.2 & C-302	
<input checked="" type="checkbox"/>	a. Utilities		
<input checked="" type="checkbox"/>	b. Drainage		
<input checked="" type="checkbox"/>	16. Monuments: (VI.16)	Subdivision Plans	
<input checked="" type="checkbox"/>	17. Benchmarks: (VI.17)	C-101.1 & C-101.2	
<input checked="" type="checkbox"/>	18. House Numbers (VI.18)	TBD	

Design Standards			
	Required Items for Submittal	Indicate compliance and/or provide explanation as to alternative design	Waiver Requested
<input checked="" type="checkbox"/>	1. Streets have been designed according to the design standards required under Section (VII.1). a. Clearing b. Excavation c. Rough Grade and Preparation of Sub-Grade d. Base Course e. Street Paving f. Side Slopes g. Approval Specifications h. Curbing i. Sidewalks j. Inspection and Methods	Roadway Plan and Profile Sheets C-201.1 & C-201.2	
<input checked="" type="checkbox"/>	2. Storm water Sewers and Other Drainage Appurtenances have been designed according to the design standards required under Section (VII.2). a. Design b. Standards of Construction	Grading and Drainage Plan Sheets C-103.1 & C-103.2	
<input checked="" type="checkbox"/>	3. Sanitary Sewers have been designed according to the design standards required under Section (VII.3). a. Design b. Lift Stations c. Materials d. Construction Standards	Utilities Plan Sheets C-104.1 & C-104.2	
<input checked="" type="checkbox"/>	4. Water Mains and Fire Hydrants have been designed according to the design standards required under Section (VII.4). a. Connections to Lots b. Design and Construction c. Materials d. Notification Prior to Construction	Utilities Plan Sheets C-104.1 & C-104.2	

¹ See City of Portsmouth, NH Subdivision Rules and Regulations for details.
Subdivision Application Checklist/September 2020

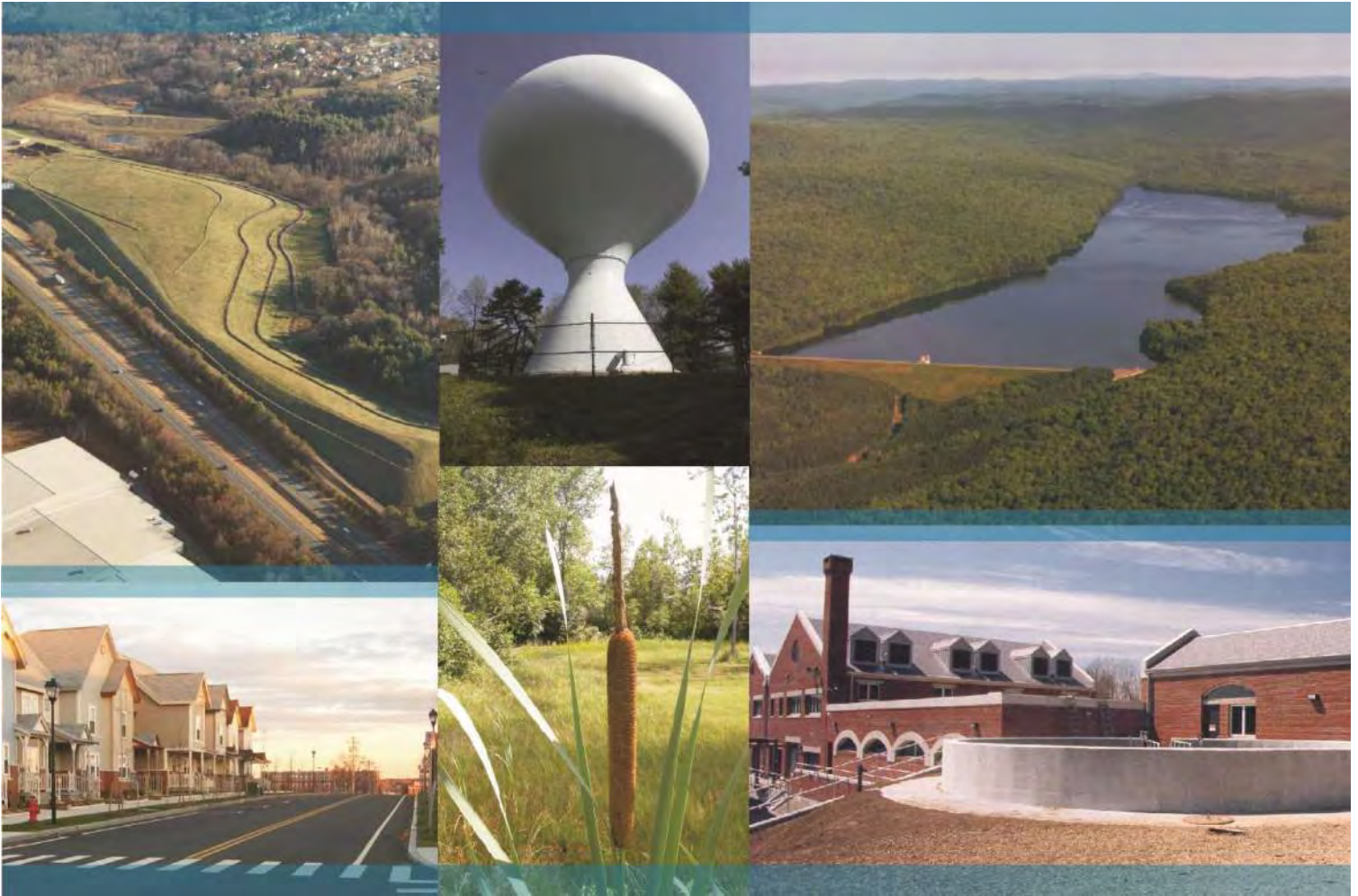

STATE OF NEW HAMPSHIRE
BRADLEE MEZQUITA
No. 08830
LICENSED PROFESSIONAL ENGINEER
Bradlee Mezquita
03/10/2021

STATE OF NEW HAMPSHIRE
PATRICK CRIMMINS
No. 12378
LICENSED PROFESSIONAL ENGINEER
Patrick Crimmings
03/10/2021

Tighe & Bond

Proposed Multi-Family Development
105 Bartlett Street
Portsmouth, NH

Drainage Analysis

Prepared For:

Iron Horse Properties LLC

April 20, 2020

Last Revised: March 10, 2021

Section 1

Project Description

The Bartlett Street property is comprised of a five (5) parcels that are bounded by Bartlett Street to the west and south, North Mill Pond to the north, and the Boston and Maine (B&M) railroad to the east. The existing parcels are listed below.

Tax Map/Lot No.	Area (ac)
157 / 1	1.42
157 / 2	2.34
164 / 1	1.19
164 / 4-2	5.73
R.O.W.	1.60

Lot 157-1 is currently occupied by a 20,000-square-foot, 2-story, concrete block/steel frame building and associated parking lot. Lot 157-2 contains another 20,000-square foot wood frame structure with a variety of outbuildings, such as sheds, to support an impervious lumber yard. Lot 164-1 also contains an approximately 20,000-square foot wood frame structure that hosts a variety of smaller businesses and associated parking. Lot 164-4-2 is currently occupied by a former B&M railroad turntable, a dilapidated former brick roundhouse, and an approximately 3,600-square-foot machine shop. Several shipping containers are also present throughout the lot. The northern end of the lot is comprised mostly of abandoned rail lines that run down the shoreline between North Mill Pond and the active railroad past the northern limits of the project site

The proposed project includes the demolition and relocation of the structures on Lots 157-1, 157-2, and 164-4-2 and construction of three (3) multi-family apartment buildings, with two (2) having basement level parking. In order to accommodate the footprints of the new structure and site improvements, the listed lots are proposed to be revised into five (5) new lots. The project will include associated site improvements that consist of a private road with cul-de-sac, parking, utilities, stormwater management and treatment, landscaping, lighting, and a greenway park. Additionally, the land from North Mill Pond’s mean high water (MHW) line to the 50ft buffer will be deeded to the City of Portsmouth and designated as community space for the City’s North Mill Pond Trail project. The City will be responsible for the future design and permitting of the North Mill Pond Trail project and any of its associated work within the 50ft buffer.

The pre-development and post-development watershed areas have been analyzed at two points of analysis. While the points of analysis remained unchanged, their contributing sub-catchment areas varied between pre-development and post-development conditions. These adjustments were made to reflect the differences in drainage patterns between the existing and proposed conditions. The overall area analyzed as part of this drainage analysis was held constant. For reference, PA-1 assesses flows that discharge directly to

North Mill Pond via overland flow or various outlets, and PA-2 assesses flows that discharge to the 36" brick sewer which runs through the development area. In the post-development condition, however, all stormwater flows have been separated from the brick sewer and are discharged to North Mill Pond after being treated. PA-2 would have no stormwater flows in the post-development condition, therefore removing the need to assess it.

Furthermore, since North Mill Pond is a tidal water, NHDES does not require peak runoff control requirements to be met (Env-Wq 1507.06(d)). For this reason, a comparison of peak runoff rates for the various storm events has not been provided. A detention system is included on the development site for the purpose of mitigating temperature differences between the stormwater runoff and the North Mill Pond.

1.1 Calculation Methods

The design storms analyzed in this study are the 2-year, 10-year, 25-year and 50-year 24-hour duration storm events. The stormwater modeling system, HydroCAD 10.0 was utilized to predict the peak runoff rates from these storm events. The peak discharge rates were determined by analyzing Type III 24-hour storm events. The rainfall data for these storm events was obtained from the data published by the Northeast Regional Climate Center at Cornell University, with an additional 15% added factor of safety as required by Env-Wq 1503.08(l).

The time of concentration was computed using the TR-55 Method, which provides a means of determining the time for an entire watershed to contribute runoff to a specific location via sheet flows, shallow concentrated flow and channel flow. Runoff curve numbers were calculated by estimating the coverage areas and then summing the curve number for the coverage area as a percent of the entire watershed.

References:

1. HydroCAD Stormwater Modeling System, by HydroCAD Software Solutions LLC, Chocorua, New Hampshire.
2. New Hampshire Stormwater Management Manual, Volume 2, Post-Construction Best Management Practices Selection and Design, December 2008.
3. "Extreme Precipitation in New York & New England." Extreme Precipitation in New York & New England by Northeast Regional Climate Center (NRCC), 26 June 2012.

Section 2

Pre-Development Conditions

In order to analyze the pre-development condition, the site has been divided into two (2) watershed areas modeled at two (2) points of analysis. These points of analysis and watersheds are depicted on the plans entitled "Pre-Development Watershed Plan", Sheets C-801.1 and C-801.2.

Each of the points of analysis and their contributing watershed areas are described below:

Point of Analysis (PA-1)

Pre-development Watershed 1.0 (PRE 1.0) is comprised of mostly impervious surfaces from paved parking and structures, as well as some disturbed forested areas to the northeast that surround a dilapidated roundhouse, former railroad turntable, and a machine shop. Banks along the shoreline of North Mill Pond consist of lawn, various species associated with disturbed sites, and rubble. Runoff from this watershed area travels via overland flow or underground drainage system to discharge into North Mill Pond. The runoff is currently untreated before discharge.

Point of Analysis (PA-2)

Pre-development Watershed 2.0 (PRE-2.0) is comprised mostly of impervious surfaces in the form of paved parking, roadway, and structures. Additional runoff comes from a grassy wooded strip that slopes down from the railroad to the east of the watershed. Runoff from this watershed drains to various catch basins that tie into an existing brick sewer.

2.2.1 Pre-Development Calculations

2.2.2 Pre-Development Watershed Plans

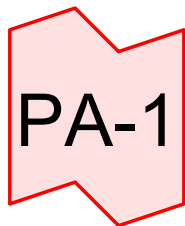

NORTH MILL POND

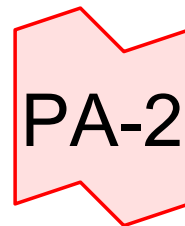
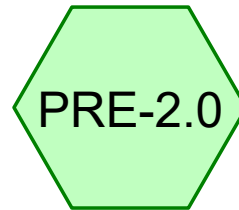

COMBINED SYSTEM
TO SEWER

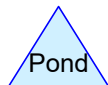
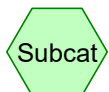

C0960-006 PRE

Prepared by Tighe & Bond

HydroCAD® 10.00-20 s/n 03436 © 2017 HydroCAD Software Solutions LLC

Printed 1/18/2021

Page 2

Area Listing (all nodes)

Area (acres)	CN	Description (subcatchment-numbers)
0.507	39	>75% Grass cover, Good, HSG A (PRE-1.0)
0.419	61	>75% Grass cover, Good, HSG B (PRE-1.0, PRE-2.0)
0.922	74	>75% Grass cover, Good, HSG C (PRE-1.0, PRE-2.0)
0.071	80	>75% Grass cover, Good, HSG D (PRE-1.0)
1.173	96	Gravel surface, HSG C (PRE-1.0, PRE-2.0)
3.596	98	Paved parking, HSG C (PRE-1.0, PRE-2.0)
1.695	98	Roofs, HSG C (PRE-1.0, PRE-2.0)
0.496	30	Woods, Good, HSG A (PRE-1.0)
0.292	55	Woods, Good, HSG B (PRE-1.0, PRE-2.0)
1.378	70	Woods, Good, HSG C (PRE-1.0, PRE-2.0)
0.306	77	Woods, Good, HSG D (PRE-1.0)
10.853	83	TOTAL AREA

C0960-006 PRE

Prepared by Tighe & Bond

HydroCAD® 10.00-20 s/n 03436 © 2017 HydroCAD Software Solutions LLC

Printed 1/18/2021

Page 3

Soil Listing (all nodes)

Area (acres)	Soil Group	Subcatchment Numbers
1.003	HSG A	PRE-1.0
0.711	HSG B	PRE-1.0, PRE-2.0
8.763	HSG C	PRE-1.0, PRE-2.0
0.376	HSG D	PRE-1.0
0.000	Other	
10.853		TOTAL AREA

C0960-006 PRE

Type III 24-hr 2-YR Rainfall=3.69"

Prepared by Tighe & Bond

Printed 1/18/2021

HydroCAD® 10.00-20 s/n 03436 © 2017 HydroCAD Software Solutions LLC

Page 4

Time span=0.00-24.00 hrs, dt=0.05 hrs, 481 points
Runoff by SCS TR-20 method, UH=SCS, Weighted-CN
Reach routing by Dyn-Stor-Ind method - Pond routing by Dyn-Stor-Ind method

Subcatchment PRE-1.0: Runoff Area=280,495 sf 37.67% Impervious Runoff Depth>1.71"
Flow Length=461' Tc=12.7 min CN=79 Runoff=10.22 cfs 0.918 af

Subcatchment PRE-2.0: Runoff Area=192,280 sf 64.91% Impervious Runoff Depth>2.62"
Flow Length=248' Tc=5.0 min CN=90 Runoff=13.43 cfs 0.965 af

Link PA-1: NORTH MILL POND Inflow=10.22 cfs 0.918 af
Primary=10.22 cfs 0.918 af

Link PA-2: COMBINED SYSTEM TO SEWER Inflow=13.43 cfs 0.965 af
Primary=13.43 cfs 0.965 af

Total Runoff Area = 10.853 ac Runoff Volume = 1.883 af Average Runoff Depth = 2.08"
51.25% Pervious = 5.563 ac 48.75% Impervious = 5.291 ac

C0960-006 PRE

Type III 24-hr 10-YR Rainfall=5.60"

Prepared by Tighe & Bond

Printed 1/18/2021

HydroCAD® 10.00-20 s/n 03436 © 2017 HydroCAD Software Solutions LLC

Page 5

Time span=0.00-24.00 hrs, dt=0.05 hrs, 481 points
Runoff by SCS TR-20 method, UH=SCS, Weighted-CN
Reach routing by Dyn-Stor-Ind method - Pond routing by Dyn-Stor-Ind method

Subcatchment PRE-1.0: Runoff Area=280,495 sf 37.67% Impervious Runoff Depth>3.32"
Flow Length=461' Tc=12.7 min CN=79 Runoff=19.96 cfs 1.780 af

Subcatchment PRE-2.0: Runoff Area=192,280 sf 64.91% Impervious Runoff Depth>4.45"
Flow Length=248' Tc=5.0 min CN=90 Runoff=22.22 cfs 1.639 af

Link PA-1: NORTH MILL POND Inflow=19.96 cfs 1.780 af
Primary=19.96 cfs 1.780 af

Link PA-2: COMBINED SYSTEM TO SEWER Inflow=22.22 cfs 1.639 af
Primary=22.22 cfs 1.639 af

Total Runoff Area = 10.853 ac Runoff Volume = 3.419 af Average Runoff Depth = 3.78"
51.25% Pervious = 5.563 ac 48.75% Impervious = 5.291 ac

Summary for Subcatchment PRE-1.0:

Runoff = 19.96 cfs @ 12.18 hrs, Volume= 1.780 af, Depth> 3.32"

Runoff by SCS TR-20 method, UH=SCS, Weighted-CN, Time Span= 0.00-24.00 hrs, dt= 0.05 hrs
Type III 24-hr 10-YR Rainfall=5.60"

Area (sf)	CN	Description
22,079	39	>75% Grass cover, Good, HSG A
21,626	30	Woods, Good, HSG A
15,637	61	>75% Grass cover, Good, HSG B
9,580	55	Woods, Good, HSG B
43,774	98	Roofs, HSG C
13,394	74	>75% Grass cover, Good, HSG C
61,882	98	Paved parking, HSG C
33,912	70	Woods, Good, HSG C
42,224	96	Gravel surface, HSG C
3,074	80	>75% Grass cover, Good, HSG D
13,313	77	Woods, Good, HSG D
280,495	79	Weighted Average
174,839		62.33% Pervious Area
105,656		37.67% Impervious Area

Tc (min)	Length (feet)	Slope (ft/ft)	Velocity (ft/sec)	Capacity (cfs)	Description
6.9	100	0.0400	0.24		Sheet Flow, Grass: Short n= 0.150 P2= 3.69"
5.8	361	0.0219	1.04		Shallow Concentrated Flow, Short Grass Pasture Kv= 7.0 fps
12.7	461	Total			

Summary for Subcatchment PRE-2.0:

[49] Hint: Tc<2dt may require smaller dt

Runoff = 22.22 cfs @ 12.07 hrs, Volume= 1.639 af, Depth> 4.45"

Runoff by SCS TR-20 method, UH=SCS, Weighted-CN, Time Span= 0.00-24.00 hrs, dt= 0.05 hrs
Type III 24-hr 10-YR Rainfall=5.60"

Area (sf)	CN	Description
2,616	61	>75% Grass cover, Good, HSG B
3,131	55	Woods, Good, HSG B
30,043	98	Roofs, HSG C
26,755	74	>75% Grass cover, Good, HSG C
94,757	98	Paved parking, HSG C
26,114	70	Woods, Good, HSG C
8,864	96	Gravel surface, HSG C
192,280	90	Weighted Average
67,480		35.09% Pervious Area
124,800		64.91% Impervious Area

Tc (min)	Length (feet)	Slope (ft/ft)	Velocity (ft/sec)	Capacity (cfs)	Description
2.1	48	0.1875	0.39		Sheet Flow, Grass: Short n= 0.150 P2= 3.69"
1.6	200	0.0100	2.03		Shallow Concentrated Flow, Paved Kv= 20.3 fps
3.7	248	Total, Increased to minimum Tc = 5.0 min			

Summary for Link PA-1: NORTH MILL POND

Inflow Area = 6.439 ac, 37.67% Impervious, Inflow Depth > 3.32" for 10-YR event
 Inflow = 19.96 cfs @ 12.18 hrs, Volume= 1.780 af
 Primary = 19.96 cfs @ 12.18 hrs, Volume= 1.780 af, Atten= 0%, Lag= 0.0 min

Primary outflow = Inflow, Time Span= 0.00-24.00 hrs, dt= 0.05 hrs

Summary for Link PA-2: COMBINED SYSTEM TO SEWER

Inflow Area = 4.414 ac, 64.91% Impervious, Inflow Depth > 4.45" for 10-YR event
 Inflow = 22.22 cfs @ 12.07 hrs, Volume= 1.639 af
 Primary = 22.22 cfs @ 12.07 hrs, Volume= 1.639 af, Atten= 0%, Lag= 0.0 min

Primary outflow = Inflow, Time Span= 0.00-24.00 hrs, dt= 0.05 hrs

C0960-006 PRE

Type III 24-hr 25-YR Rainfall=7.10"

Prepared by Tighe & Bond

Printed 1/18/2021

HydroCAD® 10.00-20 s/n 03436 © 2017 HydroCAD Software Solutions LLC

Page 8

Time span=0.00-24.00 hrs, dt=0.05 hrs, 481 points
Runoff by SCS TR-20 method, UH=SCS, Weighted-CN
Reach routing by Dyn-Stor-Ind method - Pond routing by Dyn-Stor-Ind method

Subcatchment PRE-1.0: Runoff Area=280,495 sf 37.67% Impervious Runoff Depth>4.67"
Flow Length=461' Tc=12.7 min CN=79 Runoff=28.08 cfs 2.504 af

Subcatchment PRE-2.0: Runoff Area=192,280 sf 64.91% Impervious Runoff Depth>5.92"
Flow Length=248' Tc=5.0 min CN=90 Runoff=29.06 cfs 2.177 af

Link PA-1: NORTH MILL POND Inflow=28.08 cfs 2.504 af
Primary=28.08 cfs 2.504 af

Link PA-2: COMBINED SYSTEM TO SEWER Inflow=29.06 cfs 2.177 af
Primary=29.06 cfs 2.177 af

Total Runoff Area = 10.853 ac Runoff Volume = 4.681 af Average Runoff Depth = 5.18"
51.25% Pervious = 5.563 ac 48.75% Impervious = 5.291 ac

C0960-006 PRE

Type III 24-hr 50-YR Rainfall=8.50"

Prepared by Tighe & Bond

Printed 1/18/2021

HydroCAD® 10.00-20 s/n 03436 © 2017 HydroCAD Software Solutions LLC

Page 9

Time span=0.00-24.00 hrs, dt=0.05 hrs, 481 points
Runoff by SCS TR-20 method, UH=SCS, Weighted-CN
Reach routing by Dyn-Stor-Ind method - Pond routing by Dyn-Stor-Ind method

Subcatchment PRE-1.0: Runoff Area=280,495 sf 37.67% Impervious Runoff Depth>5.96"
Flow Length=461' Tc=12.7 min CN=79 Runoff=35.62 cfs 3.200 af

Subcatchment PRE-2.0: Runoff Area=192,280 sf 64.91% Impervious Runoff Depth>7.29"
Flow Length=248' Tc=5.0 min CN=90 Runoff=35.39 cfs 2.683 af



Link PA-1: NORTH MILL POND Inflow=35.62 cfs 3.200 af
Primary=35.62 cfs 3.200 af

Link PA-2: COMBINED SYSTEM TO SEWER Inflow=35.39 cfs 2.683 af
Primary=35.39 cfs 2.683 af

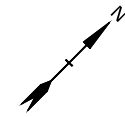
Total Runoff Area = 10.853 ac Runoff Volume = 5.883 af Average Runoff Depth = 6.50"
51.25% Pervious = 5.563 ac 48.75% Impervious = 5.291 ac

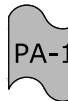

LEGEND

-  PRE-DEVELOPMENT WATERSHED BOUNDARY
-  LONGEST FLOW PATH
-  PRE DEVELOPMENT WATERSHED AREA DESIGNATION
-  POINT OF ANALYSIS

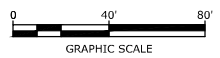
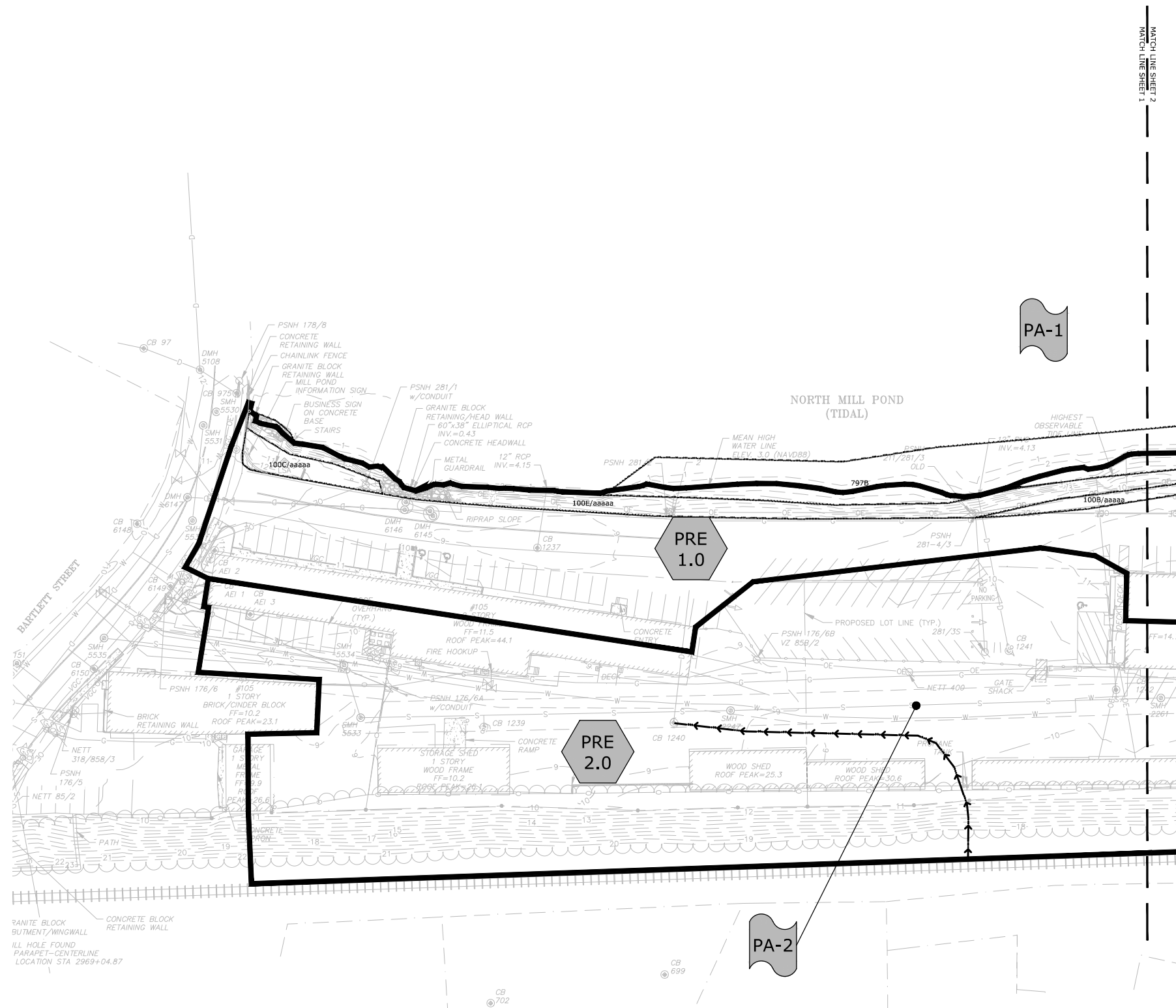

Proposed Multi-Family Development

Iron Horse Properties, LLC

105 Bartlett Street
Portsmouth,
New Hampshire

MARK	DATE	DESCRIPTION
I	2/11/2021	PB Submission
H	1/20/2021	TAC Resubmission
G	11/18/2020	TAC Resubmission
F	10/28/2020	Wetland CUP Resubmission
E	5/20/2020	TAC Resubmission
D	4/29/2020	Wetland CUP Submission
C	4/20/2020	TAC Submission
B	2/6/2020	Design Review Submission
A	1/2/2020	ZBA Submission

PROJECT NO:	C-0960-006
DATE:	April 20, 2020
FILE:	C-0960-006_C-SITE.DWG
DRAWN BY:	NAH
CHECKED:	PMC
APPROVED:	BML



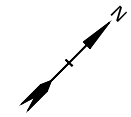

PRE-DEVELOPMENT WATERSHED PLAN

SCALE: AS SHOWN

C-801.1



LEGEND

-  PRE-DEVELOPMENT WATERSHED BOUNDARY
-  LONGEST FLOW PATH
-  PRE DEVELOPMENT WATERSHED AREA DESIGNATION
-  POINT OF ANALYSIS

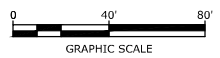
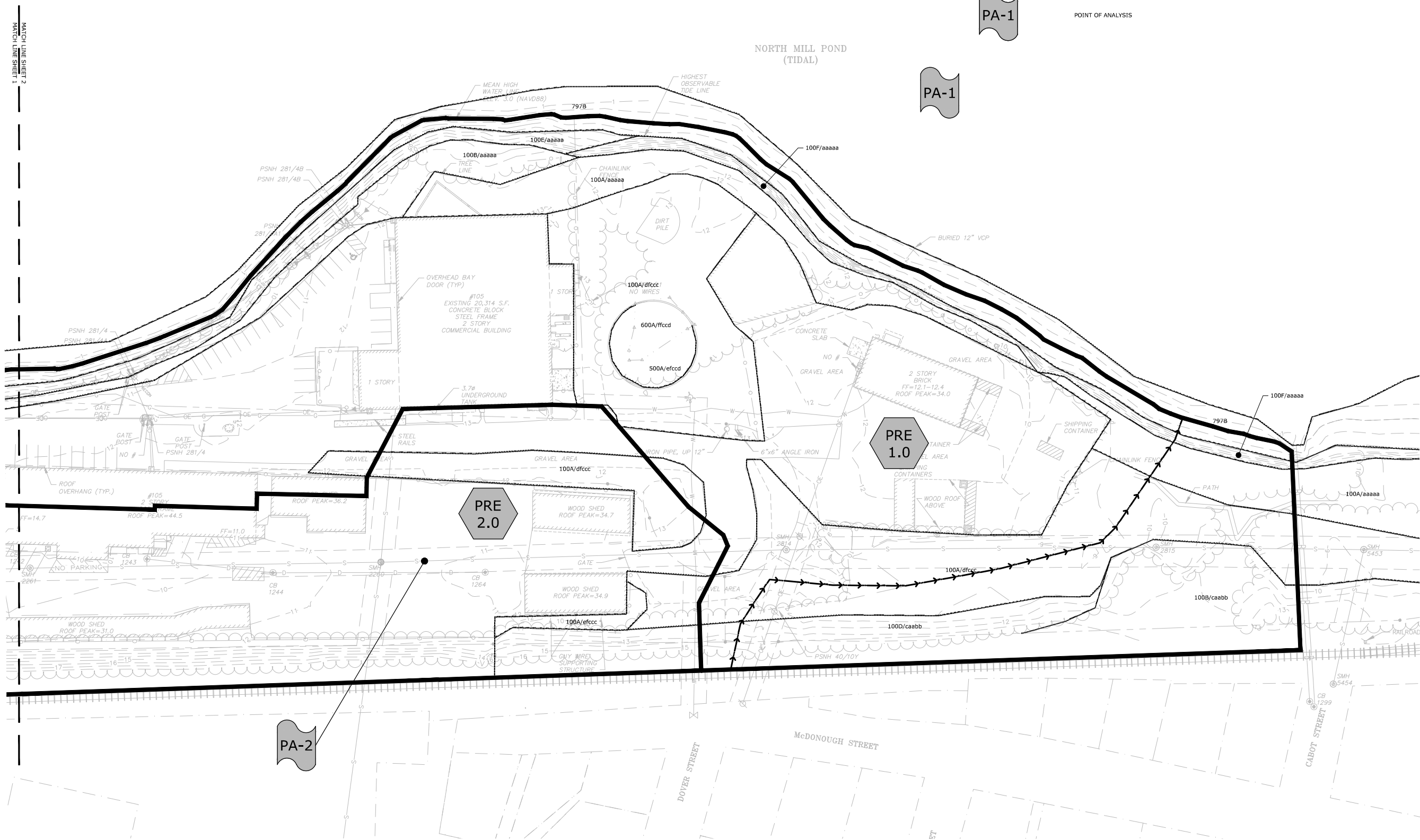

Proposed Multi-Family Development

Iron Horse Properties, LLC

105 Bartlett Street
Portsmouth,
New Hampshire

MARK	DATE	DESCRIPTION
I	2/11/2021	PB Submission
H	1/20/2021	TAC Resubmission
G	11/18/2020	TAC Resubmission
F	10/28/2020	Wetland CUP Resubmission
E	5/20/2020	TAC Resubmission
D	4/29/2020	Wetland CUP Submission
C	4/20/2020	TAC Submission
B	2/6/2020	Design Review Submission
A	1/2/2020	ZBA Submission

PROJECT NO:	C-0960-006
DATE:	April 20, 2020
FILE:	C-0960-006_C-SITE.DWG
DRAWN BY:	NAH
CHECKED:	PMC
APPROVED:	BML

PRE-DEVELOPMENT WATERSHED PLAN

SCALE: AS SHOWN

C-801.2

Last Saved: 2/8/2021
 Plotted On: Feb 08, 2021 3:02pm By: Mahanien
 Tighe & Bond: C:\C0960\Cabinets\C-0960-006 105 Bartlett Street Drawings - Figures\AutoCAD\Sheet\C-0960-006_C-SITE.dwg

Section 3

Post-Development Conditions

The post-development condition was analyzed by dividing the watersheds into nine (9) watershed areas. Stormwater runoff from these sub-catchment areas flow via subsurface drainage systems prior to discharging to North Mill Pond. Unlike in the pre-development condition, flows from these sub-catchment areas are modeled at only one point of analysis at North Mill Pond (PA-1). As previously described, a large portion of the site has been designed to reroute runoff to North Mill Pond instead of the existing brick sewer. This increases the watershed area flowing to PA-1 compared to the pre-development condition but eliminates the site's contribution to a combined sewer system. As per Env-Wq 1507.06(d), the resulting increased peak flows from a larger effective watershed area are not of concern since North Mill Pond is a tidal water and the peak runoff control requirements do not apply. For this reason, a comparison of peak runoff rates for the various storm events has not been provided.

A detention system is included on the development site for the purpose of mitigating temperature differences between the stormwater runoff and the North Mill Pond. The detention system and outlet structure have been sized to detain the WQV with a drain down time of 24 hours, prior to discharging to the treatment unit. Flows greater than the 2-year storm event are designed to bypass the treatment unit.

The point of analysis (PA-1) and its sub-catchment areas are depicted on the plans entitled "Post-Development Watershed Plan," Sheets C-802.1 and C-802.2. Each of the points of analysis and their contributing watershed areas are described below:

Point of Analysis (PA-1)

Post-development Watershed 1.0 (POST-1.0) is comprised of mostly existing impervious areas on the south end of the site behind some of the existing structures. Runoff from this watershed area travels via overland flow to the modified subsurface drainage system, where it is pretreated by deep-sump catch basins and treated by a Contech Jellyfish Stormwater Filter (JF-1). The Jellyfish units proposed are Contech's Peak Diversion model, which include an internal bypass that route flows greater than the design Water Quality Flow past the internal treatment system. Flows exiting the Jellyfish Filter discharge to a manhole structure outfitted with a backflow preventer within the outlet invert to protect the drainage system from tidal backflow and flooding. Flows then directly discharge to North Mill Pond (PA-1), through an outfall protected by a concrete winged headwall and plunge pool.

Post-development Watershed 1.1 (POST-1.1) collects the runoff from the modified roadway and parking areas at the entrance of the site. Runoff from this watershed area travels via overland flow to deep-sump catch basins that tie into a structure (PDMH3) just upstream of the Jellyfish Filter described in POST 1.0 (JF-1). Runoff is treated and discharged through manhole structure equipped with a backflow preventer before exiting to North Mill Pond (PA-1). A concrete winged headwall and plunge pool provide erosion control and bank stability to the outfall.

Post-development Watershed 2.0 (POST-2.0) is comprised mostly of asphalt roadway and concrete sidewalks in the center of the site. Runoff from this watershed area travels via

overland flow to deep-sump catch basins and a Contech Jellyfish Stormwater Filter (JF-2). Flows exiting the Jellyfish Filter tie into a manhole structure that combines the flows with those of POST-1.0 before similarly exiting to North Mill Pond.

Post-development Watershed 3.0 (POST-3.0) primarily collects the roof runoff from two (2) of the proposed buildings, as well as some additional impervious cover below. Runoff from this watershed area travels via roof leaders or yard drains to a Contech Jellyfish Stormwater Filter (JF-3). Flows exiting the Jellyfish Filter discharge to North Mill Pond (PA-1). Similar to Post-Development Watershed 1.0 (POST-1.0), the pipe network is protected by a backflow preventer within the outlet invert of a manhole structure at the most downstream location. A concrete winged headwall and plunge pool provide erosion control and bank stability to the outfall.

Post-development Watershed 4.0 (POST-4.0) collects the roof runoff from the third proposed building, paved parking, and some forested grassy slopes parallel to the existing railroad. Runoff from this watershed area travels via overland flow or roof leader to deep sump catch basins and an underground detention system. The detention system and outlet structure have been sized to detain the WQV with a drain down time of 24 hours, prior to discharging to the treatment unit, a Contech Jellyfish Stormwater Filter (JF-4). Flows exiting the Jellyfish Filter discharge to North Mill Pond (PA-1). Similar to Post-Development Watershed 1.0 (POST-1.0), the pipe network is protected by a backflow preventer within the outlet invert of a manhole structure at the most downstream location. A concrete winged headwall and plunge pool provide erosion control and bank stability to the outfall.

Post-development Watershed 5.0 (POST-5.0) is comprised mostly of porous pavement multi use path located between the proposed development and the North Mill Pond. Runoff from the watershed infiltrates through the filter media section under the porous pavement and discharges to an underdrain. The underdrain connects to the closed drainage system on site, ultimately discharging to the North Mill Pond.

Post-development Watershed 5.1 (POST-5.1) is comprised of porous pavement multi use path and landscaped park area located between the proposed development and the North Mill Pond. Runoff from the watershed infiltrates through the filter media section under the porous pavement and discharges to an underdrain. The underdrain connects to the closed drainage system on site, ultimately discharging to the North Mill Pond.

Post-development Watershed 6.0 (POST-6.0) is comprised mostly of grassy and slightly forested areas along the shoreline of North Mill Pond. Runoff from this watershed simply sheets toward and discharges into North Mill Pond, as in the existing condition. There are no proposed impervious surfaces that are within this watershed area that would require treatment.

Post-development Watershed 7.0 (POST-7.0) collects the runoff from the small area of the proposed greenway park area behind the proposed buildings. A circular rain garden (RG-1), paired with an outlet control structure, has been designed to provide treatment for the runoff from this area. The outlet control structure directs flows to a manhole structure downstream that combines flows with those of POST-4.0 before exiting to North Mill Pond.

Point of Analysis (PA-2)

All runoff previously draining to the existing brick sewer (PA-2) is proposed to be diverted to underground drainage that flows to North Mill Pond, effectively eliminating all flows to this point of analysis from this site.

3.3.1 Post-Development Calculations

3.3.2 Post-Development Watershed Plans

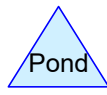
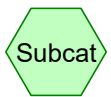
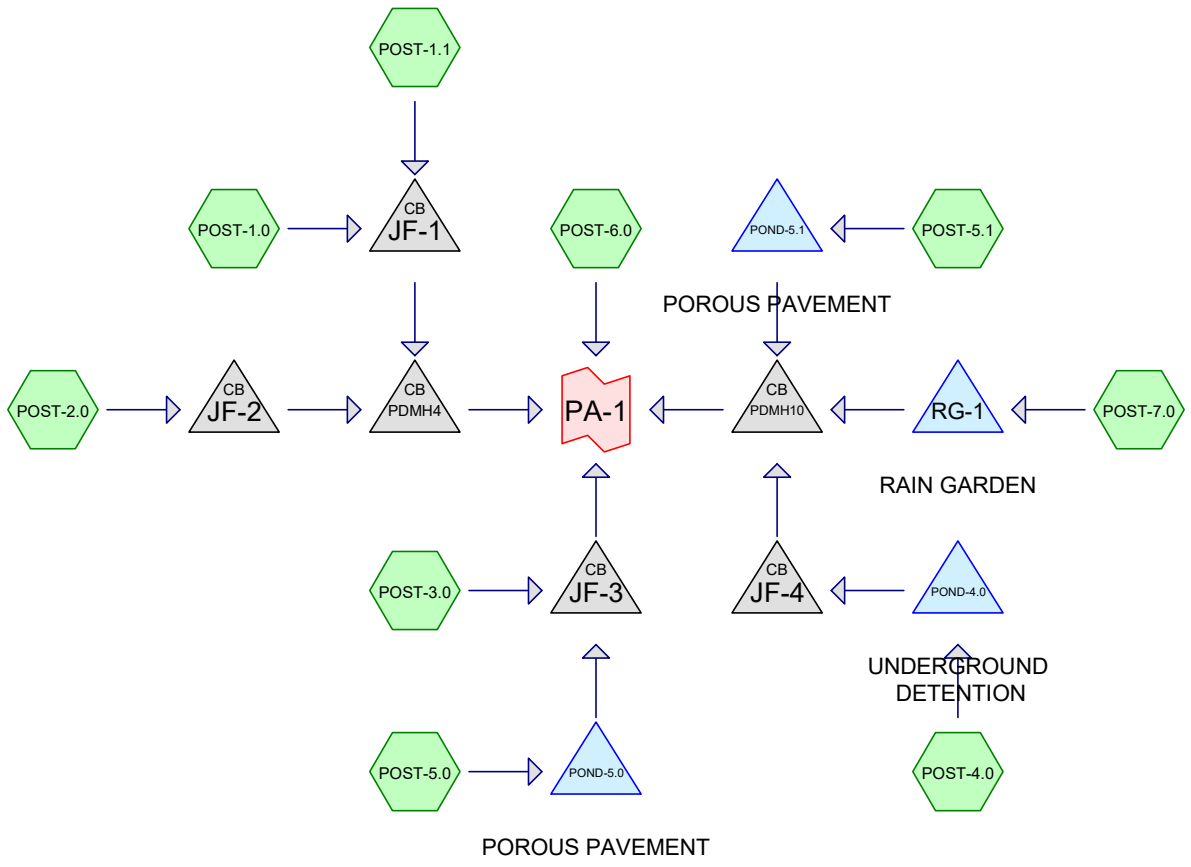

Routing Diagram for C0960-006 POST
 Prepared by Tighe & Bond, Printed 2/9/2021
 HydroCAD® 10.00-20 s/n 03436 © 2017 HydroCAD Software Solutions LLC

C0960-006 POST

Prepared by Tighe & Bond

HydroCAD® 10.00-20 s/n 03436 © 2017 HydroCAD Software Solutions LLC

Printed 2/9/2021

Page 11

Area Listing (selected nodes)

Area (acres)	CN	Description (subcatchment-numbers)
0.480	39	>75% Grass cover, Good, HSG A (POST-3.0, POST-5.0, POST-6.0)
0.417	61	>75% Grass cover, Good, HSG B (POST-4.0, POST-6.0)
1.752	74	>75% Grass cover, Good, HSG C (POST-1.0, POST-1.1, POST-2.0, POST-3.0, POST-4.0, POST-5.0, POST-5.1, POST-6.0, POST-7.0)
0.077	80	>75% Grass cover, Good, HSG D (POST-5.1, POST-6.0)
0.421	89	Gravel roads, HSG C (POST-1.0)
0.055	98	Paved parking, HSG A (POST-1.1, POST-3.0, POST-5.0)
0.209	98	Paved parking, HSG B (POST-4.0)
3.919	98	Paved parking, HSG C (POST-1.0, POST-1.1, POST-2.0, POST-3.0, POST-4.0, POST-5.0, POST-5.1)
1.921	98	Roofs, HSG C (POST-1.0, POST-1.1, POST-2.0, POST-3.0, POST-4.0)
0.028	98	Roofs, HSG D (POST-3.0)
0.469	30	Woods, Good, HSG A (POST-6.0)
0.085	55	Woods, Good, HSG B (POST-4.0, POST-6.0)
0.752	70	Woods, Good, HSG C (POST-1.0, POST-4.0, POST-6.0)
0.270	83	Woods, Poor, HSG D (POST-6.0)
10.853	84	TOTAL AREA

C0960-006 POST

Prepared by Tighe & Bond

HydroCAD® 10.00-20 s/n 03436 © 2017 HydroCAD Software Solutions LLC

Printed 2/9/2021

Page 12

Soil Listing (selected nodes)

Area (acres)	Soil Group	Subcatchment Numbers
1.003	HSG A	POST-1.1, POST-3.0, POST-5.0, POST-6.0
0.711	HSG B	POST-4.0, POST-6.0
8.763	HSG C	POST-1.0, POST-1.1, POST-2.0, POST-3.0, POST-4.0, POST-5.0, POST-5.1, POST-6.0, POST-7.0
0.376	HSG D	POST-3.0, POST-5.1, POST-6.0
0.000	Other	
10.853		TOTAL AREA

C0960-006 POST

Type III 24-hr 2-YR Rainfall=3.69"

Prepared by Tighe & Bond

Printed 2/9/2021

HydroCAD® 10.00-20 s/n 03436 © 2017 HydroCAD Software Solutions LLC

Page 13

Time span=0.00-24.00 hrs, dt=0.05 hrs, 481 points
 Runoff by SCS TR-20 method, UH=SCS, Weighted-CN
 Reach routing by Dyn-Stor-Ind method - Pond routing by Dyn-Stor-Ind method

Subcatchment POST-1.0:	Runoff Area=129,041 sf 66.78% Impervious Runoff Depth>2.72" Tc=5.0 min CN=91 Runoff=9.28 cfs 0.671 af
Subcatchment POST-1.1:	Runoff Area=42,709 sf 91.75% Impervious Runoff Depth>3.23" Tc=5.0 min CN=96 Runoff=3.45 cfs 0.264 af
Subcatchment POST-2.0:	Runoff Area=32,330 sf 86.24% Impervious Runoff Depth>3.12" Tc=5.0 min CN=95 Runoff=2.56 cfs 0.193 af
Subcatchment POST-3.0:	Runoff Area=50,366 sf 70.02% Impervious Runoff Depth>2.53" Tc=5.0 min CN=89 Runoff=3.41 cfs 0.244 af
Subcatchment POST-4.0:	Runoff Area=96,700 sf 66.72% Impervious Runoff Depth>2.35" Tc=5.0 min CN=87 Runoff=6.09 cfs 0.435 af
Subcatchment POST-5.0:	Runoff Area=5,912 sf 65.31% Impervious Runoff Depth>2.18" Tc=5.0 min CN=85 Runoff=0.35 cfs 0.025 af
Subcatchment POST-5.1:	Runoff Area=26,210 sf 38.86% Impervious Runoff Depth>2.02" Tc=5.0 min CN=83 Runoff=1.43 cfs 0.101 af
Subcatchment POST-6.0:	Runoff Area=85,650 sf 0.00% Impervious Runoff Depth>0.49" Tc=5.0 min CN=57 Runoff=0.70 cfs 0.080 af
Subcatchment POST-7.0:	Runoff Area=3,857 sf 0.00% Impervious Runoff Depth>1.37" Tc=5.0 min CN=74 Runoff=0.14 cfs 0.010 af
Pond JF-1:	Peak Elev=6.30' Inflow=12.73 cfs 0.935 af 24.0" Round Culvert n=0.013 L=4.0' S=0.0125 '/' Outflow=12.73 cfs 0.935 af
Pond JF-2:	Peak Elev=6.29' Inflow=2.56 cfs 0.193 af 15.0" Round Culvert n=0.013 L=50.0' S=0.0040 '/' Outflow=2.56 cfs 0.193 af
Pond JF-3:	Peak Elev=4.32' Inflow=3.41 cfs 0.251 af 18.0" Round Culvert n=0.013 L=5.0' S=0.0200 '/' Outflow=3.41 cfs 0.251 af
Pond JF-4:	Peak Elev=5.03' Inflow=2.99 cfs 0.314 af 15.0" Round Culvert n=0.013 L=55.0' S=0.0055 '/' Outflow=2.99 cfs 0.314 af
Pond PDMH10:	Peak Elev=4.47' Inflow=3.10 cfs 0.379 af 24.0" Round Culvert n=0.013 L=37.0' S=0.0054 '/' Outflow=3.10 cfs 0.379 af
Pond PDMH4:	Peak Elev=5.70' Inflow=15.29 cfs 1.129 af 24.0" Round Culvert n=0.013 L=11.0' S=0.0045 '/' Outflow=15.29 cfs 1.129 af
Pond POND-4.0: UNDERGROUND DETENTION	Peak Elev=7.07' Storage=6,904 cf Inflow=6.09 cfs 0.435 af Outflow=2.99 cfs 0.314 af

C0960-006 POST

Prepared by Tighe & Bond

HydroCAD® 10.00-20 s/n 03436 © 2017 HydroCAD Software Solutions LLC

Type III 24-hr 2-YR Rainfall=3.69"

Printed 2/9/2021

Page 14

Pond POND-5.0: POROUS PAVEMENT

Peak Elev=8.95' Storage=803 cf Inflow=0.35 cfs 0.025 af
Outflow=0.01 cfs 0.007 af

Pond POND-5.1: POROUS PAVEMENT

Peak Elev=9.19' Storage=2,186 cf Inflow=1.43 cfs 0.101 af
Outflow=0.24 cfs 0.065 af

Pond RG-1: RAIN GARDEN

Peak Elev=8.45' Storage=441 cf Inflow=0.14 cfs 0.010 af
Outflow=0.00 cfs 0.000 af

Link PA-1:

Inflow=19.70 cfs 1.839 af
Primary=19.70 cfs 1.839 af

Total Runoff Area = 10.853 ac Runoff Volume = 2.024 af Average Runoff Depth = 2.24"
43.51% Pervious = 4.722 ac 56.49% Impervious = 6.131 ac

C0960-006 POST

Prepared by Tighe & Bond

HydroCAD® 10.00-20 s/n 03436 © 2017 HydroCAD Software Solutions LLC

Type III 24-hr 10-YR Rainfall=5.60"

Printed 2/9/2021

Page 15

Time span=0.00-24.00 hrs, dt=0.05 hrs, 481 points
 Runoff by SCS TR-20 method, UH=SCS, Weighted-CN
 Reach routing by Dyn-Stor-Ind method - Pond routing by Dyn-Stor-Ind method

Subcatchment POST-1.0:	Runoff Area=129,041 sf 66.78% Impervious Runoff Depth>4.56" Tc=5.0 min CN=91 Runoff=15.16 cfs 1.127 af
Subcatchment POST-1.1:	Runoff Area=42,709 sf 91.75% Impervious Runoff Depth>5.13" Tc=5.0 min CN=96 Runoff=5.34 cfs 0.419 af
Subcatchment POST-2.0:	Runoff Area=32,330 sf 86.24% Impervious Runoff Depth>5.01" Tc=5.0 min CN=95 Runoff=4.00 cfs 0.310 af
Subcatchment POST-3.0:	Runoff Area=50,366 sf 70.02% Impervious Runoff Depth>4.35" Tc=5.0 min CN=89 Runoff=5.72 cfs 0.419 af
Subcatchment POST-4.0:	Runoff Area=96,700 sf 66.72% Impervious Runoff Depth>4.13" Tc=5.0 min CN=87 Runoff=10.56 cfs 0.765 af
Subcatchment POST-5.0:	Runoff Area=5,912 sf 65.31% Impervious Runoff Depth>3.92" Tc=5.0 min CN=85 Runoff=0.62 cfs 0.044 af
Subcatchment POST-5.1:	Runoff Area=26,210 sf 38.86% Impervious Runoff Depth>3.72" Tc=5.0 min CN=83 Runoff=2.62 cfs 0.186 af
Subcatchment POST-6.0:	Runoff Area=85,650 sf 0.00% Impervious Runoff Depth>1.44" Tc=5.0 min CN=57 Runoff=2.99 cfs 0.235 af
Subcatchment POST-7.0:	Runoff Area=3,857 sf 0.00% Impervious Runoff Depth>2.85" Tc=5.0 min CN=74 Runoff=0.30 cfs 0.021 af
Pond JF-1:	Peak Elev=8.44' Inflow=20.50 cfs 1.546 af 24.0" Round Culvert n=0.013 L=4.0' S=0.0125 '/' Outflow=20.50 cfs 1.546 af
Pond JF-2:	Peak Elev=7.21' Inflow=4.00 cfs 0.310 af 15.0" Round Culvert n=0.013 L=50.0' S=0.0040 '/' Outflow=4.00 cfs 0.310 af
Pond JF-3:	Peak Elev=4.71' Inflow=5.72 cfs 0.445 af 18.0" Round Culvert n=0.013 L=5.0' S=0.0200 '/' Outflow=5.72 cfs 0.445 af
Pond JF-4:	Peak Elev=6.72' Inflow=7.84 cfs 0.640 af 15.0" Round Culvert n=0.013 L=55.0' S=0.0055 '/' Outflow=7.84 cfs 0.640 af
Pond PDMH10:	Peak Elev=5.14' Inflow=8.36 cfs 0.797 af 24.0" Round Culvert n=0.013 L=37.0' S=0.0054 '/' Outflow=8.36 cfs 0.797 af
Pond PDMH4:	Peak Elev=6.85' Inflow=24.50 cfs 1.856 af 24.0" Round Culvert n=0.013 L=11.0' S=0.0045 '/' Outflow=24.50 cfs 1.856 af
Pond POND-4.0: UNDERGROUND	Peak Elev=7.53' Storage=8,869 cf Inflow=10.56 cfs 0.765 af Outflow=7.84 cfs 0.640 af

C0960-006 POST

Prepared by Tighe & Bond

HydroCAD® 10.00-20 s/n 03436 © 2017 HydroCAD Software Solutions LLC

Type III 24-hr 10-YR Rainfall=5.60"

Printed 2/9/2021

Page 16

Pond POND-5.0: POROUS PAVEMENT Peak Elev=9.10' Storage=1,021 cf Inflow=0.62 cfs 0.044 af
Outflow=0.13 cfs 0.027 af

Pond POND-5.1: POROUS PAVEMENT Peak Elev=9.71' Storage=3,586 cf Inflow=2.62 cfs 0.186 af
Outflow=0.72 cfs 0.149 af

Pond RG-1: RAIN GARDEN Peak Elev=10.00' Storage=597 cf Inflow=0.30 cfs 0.021 af
Outflow=0.03 cfs 0.007 af

Link PA-1: Inflow=40.92 cfs 3.333 af
Primary=40.92 cfs 3.333 af

Total Runoff Area = 10.853 ac Runoff Volume = 3.526 af Average Runoff Depth = 3.90"
43.51% Pervious = 4.722 ac 56.49% Impervious = 6.131 ac

C0960-006 POST

Prepared by Tighe & Bond

HydroCAD® 10.00-20 s/n 03436 © 2017 HydroCAD Software Solutions LLC

Type III 24-hr 10-YR Rainfall=5.60"

Printed 2/9/2021

Page 17

Summary for Subcatchment POST-1.0:

[49] Hint: Tc<2dt may require smaller dt

Runoff = 15.16 cfs @ 12.07 hrs, Volume= 1.127 af, Depth> 4.56"

Runoff by SCS TR-20 method, UH=SCS, Weighted-CN, Time Span= 0.00-24.00 hrs, dt= 0.05 hrs
Type III 24-hr 10-YR Rainfall=5.60"

Area (sf)	CN	Description
27,484	98	Roofs, HSG C
576	74	>75% Grass cover, Good, HSG C
58,692	98	Paved parking, HSG C
23,967	70	Woods, Good, HSG C
18,322	89	Gravel roads, HSG C
129,041	91	Weighted Average
42,865		33.22% Pervious Area
86,176		66.78% Impervious Area

Tc (min)	Length (feet)	Slope (ft/ft)	Velocity (ft/sec)	Capacity (cfs)	Description
5.0					Direct Entry,

Summary for Subcatchment POST-1.1:

[49] Hint: Tc<2dt may require smaller dt

Runoff = 5.34 cfs @ 12.07 hrs, Volume= 0.419 af, Depth> 5.13"

Runoff by SCS TR-20 method, UH=SCS, Weighted-CN, Time Span= 0.00-24.00 hrs, dt= 0.05 hrs
Type III 24-hr 10-YR Rainfall=5.60"

Area (sf)	CN	Description
5	98	Paved parking, HSG A
5,020	98	Roofs, HSG C
3,525	74	>75% Grass cover, Good, HSG C
34,159	98	Paved parking, HSG C
42,709	96	Weighted Average
3,525		8.25% Pervious Area
39,184		91.75% Impervious Area

Tc (min)	Length (feet)	Slope (ft/ft)	Velocity (ft/sec)	Capacity (cfs)	Description
5.0					Direct Entry,

C0960-006 POST

Prepared by Tighe & Bond

HydroCAD® 10.00-20 s/n 03436 © 2017 HydroCAD Software Solutions LLC

Type III 24-hr 10-YR Rainfall=5.60"

Printed 2/9/2021

Page 18

Summary for Subcatchment POST-2.0:

[49] Hint: Tc<2dt may require smaller dt

Runoff = 4.00 cfs @ 12.07 hrs, Volume= 0.310 af, Depth> 5.01"

Runoff by SCS TR-20 method, UH=SCS, Weighted-CN, Time Span= 0.00-24.00 hrs, dt= 0.05 hrs
Type III 24-hr 10-YR Rainfall=5.60"

Area (sf)	CN	Description
6,843	98	Roofs, HSG C
4,447	74	>75% Grass cover, Good, HSG C
21,040	98	Paved parking, HSG C
32,330	95	Weighted Average
4,447		13.76% Pervious Area
27,883		86.24% Impervious Area

Tc (min)	Length (feet)	Slope (ft/ft)	Velocity (ft/sec)	Capacity (cfs)	Description
5.0					Direct Entry,

Summary for Subcatchment POST-3.0:

[49] Hint: Tc<2dt may require smaller dt

Runoff = 5.72 cfs @ 12.07 hrs, Volume= 0.419 af, Depth> 4.35"

Runoff by SCS TR-20 method, UH=SCS, Weighted-CN, Time Span= 0.00-24.00 hrs, dt= 0.05 hrs
Type III 24-hr 10-YR Rainfall=5.60"

Area (sf)	CN	Description
1,942	39	>75% Grass cover, Good, HSG A
69	98	Paved parking, HSG A
32,010	98	Roofs, HSG C
13,159	74	>75% Grass cover, Good, HSG C
1,949	98	Paved parking, HSG C
1,237	98	Roofs, HSG D
50,366	89	Weighted Average
15,101		29.98% Pervious Area
35,265		70.02% Impervious Area

Tc (min)	Length (feet)	Slope (ft/ft)	Velocity (ft/sec)	Capacity (cfs)	Description
5.0					Direct Entry,

C0960-006 POST

Prepared by Tighe & Bond

HydroCAD® 10.00-20 s/n 03436 © 2017 HydroCAD Software Solutions LLC

Type III 24-hr 10-YR Rainfall=5.60"

Printed 2/9/2021

Page 19

Summary for Subcatchment POST-4.0:

[49] Hint: Tc<2dt may require smaller dt

Runoff = 10.56 cfs @ 12.07 hrs, Volume= 0.765 af, Depth> 4.13"

Runoff by SCS TR-20 method, UH=SCS, Weighted-CN, Time Span= 0.00-24.00 hrs, dt= 0.05 hrs
Type III 24-hr 10-YR Rainfall=5.60"

Area (sf)	CN	Description
15,366	61	>75% Grass cover, Good, HSG B
9,099	98	Paved parking, HSG B
3,314	55	Woods, Good, HSG B
12,311	98	Roofs, HSG C
11,567	74	>75% Grass cover, Good, HSG C
43,113	98	Paved parking, HSG C
1,930	70	Woods, Good, HSG C
96,700	87	Weighted Average
32,177		33.28% Pervious Area
64,523		66.72% Impervious Area

Tc (min)	Length (feet)	Slope (ft/ft)	Velocity (ft/sec)	Capacity (cfs)	Description
5.0					Direct Entry,

Summary for Subcatchment POST-5.0:

[49] Hint: Tc<2dt may require smaller dt

Runoff = 0.62 cfs @ 12.07 hrs, Volume= 0.044 af, Depth> 3.92"

Runoff by SCS TR-20 method, UH=SCS, Weighted-CN, Time Span= 0.00-24.00 hrs, dt= 0.05 hrs
Type III 24-hr 10-YR Rainfall=5.60"

Area (sf)	CN	Description
763	39	>75% Grass cover, Good, HSG A
2,310	98	Paved parking, HSG A
1,288	74	>75% Grass cover, Good, HSG C
1,551	98	Paved parking, HSG C
5,912	85	Weighted Average
2,051		34.69% Pervious Area
3,861		65.31% Impervious Area

Tc (min)	Length (feet)	Slope (ft/ft)	Velocity (ft/sec)	Capacity (cfs)	Description
5.0					Direct Entry,

C0960-006 POST

Prepared by Tighe & Bond

HydroCAD® 10.00-20 s/n 03436 © 2017 HydroCAD Software Solutions LLC

Type III 24-hr 10-YR Rainfall=5.60"

Printed 2/9/2021

Page 20

Summary for Subcatchment POST-5.1:

[49] Hint: Tc<2dt may require smaller dt

Runoff = 2.62 cfs @ 12.07 hrs, Volume= 0.186 af, Depth> 3.72"

Runoff by SCS TR-20 method, UH=SCS, Weighted-CN, Time Span= 0.00-24.00 hrs, dt= 0.05 hrs
Type III 24-hr 10-YR Rainfall=5.60"

Area (sf)	CN	Description
15,734	74	>75% Grass cover, Good, HSG C
10,186	98	Paved parking, HSG C
290	80	>75% Grass cover, Good, HSG D
26,210	83	Weighted Average
16,024		61.14% Pervious Area
10,186		38.86% Impervious Area

Tc (min)	Length (feet)	Slope (ft/ft)	Velocity (ft/sec)	Capacity (cfs)	Description
5.0					Direct Entry,

Summary for Subcatchment POST-6.0:

[49] Hint: Tc<2dt may require smaller dt

Runoff = 2.99 cfs @ 12.09 hrs, Volume= 0.235 af, Depth> 1.44"

Runoff by SCS TR-20 method, UH=SCS, Weighted-CN, Time Span= 0.00-24.00 hrs, dt= 0.05 hrs
Type III 24-hr 10-YR Rainfall=5.60"

Area (sf)	CN	Description
18,189	39	>75% Grass cover, Good, HSG A
20,427	30	Woods, Good, HSG A
2,779	61	>75% Grass cover, Good, HSG B
406	55	Woods, Good, HSG B
22,150	74	>75% Grass cover, Good, HSG C
6,839	70	Woods, Good, HSG C
3,085	80	>75% Grass cover, Good, HSG D
11,775	83	Woods, Poor, HSG D
85,650	57	Weighted Average
85,650		100.00% Pervious Area

Tc (min)	Length (feet)	Slope (ft/ft)	Velocity (ft/sec)	Capacity (cfs)	Description
5.0					Direct Entry,

C0960-006 POST

Type III 24-hr 10-YR Rainfall=5.60"

Prepared by Tighe & Bond

Printed 2/9/2021

HydroCAD® 10.00-20 s/n 03436 © 2017 HydroCAD Software Solutions LLC

Page 21

Summary for Subcatchment POST-7.0:

[49] Hint: Tc<2dt may require smaller dt

Runoff = 0.30 cfs @ 12.08 hrs, Volume= 0.021 af, Depth> 2.85"

Runoff by SCS TR-20 method, UH=SCS, Weighted-CN, Time Span= 0.00-24.00 hrs, dt= 0.05 hrs
Type III 24-hr 10-YR Rainfall=5.60"

Area (sf)	CN	Description
3,857	74	>75% Grass cover, Good, HSG C
3,857		100.00% Pervious Area

Tc (min)	Length (feet)	Slope (ft/ft)	Velocity (ft/sec)	Capacity (cfs)	Description
5.0					Direct Entry,

Summary for Pond JF-1:

Inflow Area = 3.943 ac, 72.99% Impervious, Inflow Depth > 4.70" for 10-YR event
 Inflow = 20.50 cfs @ 12.07 hrs, Volume= 1.546 af
 Outflow = 20.50 cfs @ 12.07 hrs, Volume= 1.546 af, Atten= 0%, Lag= 0.0 min
 Primary = 20.50 cfs @ 12.07 hrs, Volume= 1.546 af

Routing by Dyn-Stor-Ind method, Time Span= 0.00-24.00 hrs, dt= 0.05 hrs
 Peak Elev= 8.44' @ 12.10 hrs
 Flood Elev= 10.80'

Device	Routing	Invert	Outlet Devices
#1	Primary	3.45'	24.0" Round Culvert L= 4.0' Ke= 0.500 Inlet / Outlet Invert= 3.45' / 3.40' S= 0.0125 '/' Cc= 0.900 n= 0.013, Flow Area= 3.14 sf

Primary OutFlow Max=17.25 cfs @ 12.07 hrs HW=8.03' TW=6.73' (Dynamic Tailwater)
 ↑**1=Culvert** (Inlet Controls 17.25 cfs @ 5.49 fps)

Summary for Pond JF-2:

Inflow Area = 0.742 ac, 86.24% Impervious, Inflow Depth > 5.01" for 10-YR event
 Inflow = 4.00 cfs @ 12.07 hrs, Volume= 0.310 af
 Outflow = 4.00 cfs @ 12.07 hrs, Volume= 0.310 af, Atten= 0%, Lag= 0.0 min
 Primary = 4.00 cfs @ 12.07 hrs, Volume= 0.310 af

Routing by Dyn-Stor-Ind method, Time Span= 0.00-24.00 hrs, dt= 0.05 hrs
 Peak Elev= 7.21' @ 12.11 hrs
 Flood Elev= 10.25'

Device	Routing	Invert	Outlet Devices
#1	Primary	5.30'	15.0" Round Culvert L= 50.0' Ke= 0.500 Inlet / Outlet Invert= 5.30' / 5.10' S= 0.0040 '/' Cc= 0.900

C0960-006 POST

Prepared by Tighe & Bond

HydroCAD® 10.00-20 s/n 03436 © 2017 HydroCAD Software Solutions LLC

Type III 24-hr 10-YR Rainfall=5.60"

Printed 2/9/2021

Page 22

n= 0.013, Flow Area= 1.23 sf

Primary OutFlow Max=2.03 cfs @ 12.07 hrs HW=6.85' TW=6.74' (Dynamic Tailwater)↑**1=Culvert** (Inlet Controls 2.03 cfs @ 1.66 fps)**Summary for Pond JF-3:**

Inflow Area = 1.292 ac, 69.52% Impervious, Inflow Depth > 4.14" for 10-YR event
 Inflow = 5.72 cfs @ 12.07 hrs, Volume= 0.445 af
 Outflow = 5.72 cfs @ 12.07 hrs, Volume= 0.445 af, Atten= 0%, Lag= 0.0 min
 Primary = 5.72 cfs @ 12.07 hrs, Volume= 0.445 af

Routing by Dyn-Stor-Ind method, Time Span= 0.00-24.00 hrs, dt= 0.05 hrs

Peak Elev= 4.71' @ 12.07 hrs

Flood Elev= 13.00'

Device	Routing	Invert	Outlet Devices
#1	Primary	3.30'	18.0" Round Culvert L= 5.0' Ke= 0.500 Inlet / Outlet Invert= 3.30' / 3.20' S= 0.0200 '/ Cc= 0.900 n= 0.013, Flow Area= 1.77 sf

Primary OutFlow Max=5.51 cfs @ 12.07 hrs HW=4.67' TW=0.00' (Dynamic Tailwater)↑**1=Culvert** (Barrel Controls 5.51 cfs @ 4.26 fps)**Summary for Pond JF-4:**

Inflow Area = 2.220 ac, 66.72% Impervious, Inflow Depth > 3.46" for 10-YR event
 Inflow = 7.84 cfs @ 12.10 hrs, Volume= 0.640 af
 Outflow = 7.84 cfs @ 12.10 hrs, Volume= 0.640 af, Atten= 0%, Lag= 0.0 min
 Primary = 7.84 cfs @ 12.10 hrs, Volume= 0.640 af

Routing by Dyn-Stor-Ind method, Time Span= 0.00-24.00 hrs, dt= 0.05 hrs

Peak Elev= 6.72' @ 12.10 hrs

Flood Elev= 13.25'

Device	Routing	Invert	Outlet Devices
#1	Primary	4.00'	15.0" Round Culvert L= 55.0' Ke= 0.500 Inlet / Outlet Invert= 4.00' / 3.70' S= 0.0055 '/ Cc= 0.900 n= 0.013, Flow Area= 1.23 sf

Primary OutFlow Max=7.40 cfs @ 12.10 hrs HW=6.72' TW=5.14' (Dynamic Tailwater)↑**1=Culvert** (Outlet Controls 7.40 cfs @ 6.03 fps)**Summary for Pond PDMH10:**

Inflow Area = 2.910 ac, 58.93% Impervious, Inflow Depth > 3.28" for 10-YR event
 Inflow = 8.36 cfs @ 12.10 hrs, Volume= 0.797 af
 Outflow = 8.36 cfs @ 12.10 hrs, Volume= 0.797 af, Atten= 0%, Lag= 0.0 min
 Primary = 8.36 cfs @ 12.10 hrs, Volume= 0.797 af

Routing by Dyn-Stor-Ind method, Time Span= 0.00-24.00 hrs, dt= 0.05 hrs

C0960-006 POST

Type III 24-hr 10-YR Rainfall=5.60"

Prepared by Tighe & Bond

Printed 2/9/2021

HydroCAD® 10.00-20 s/n 03436 © 2017 HydroCAD Software Solutions LLC

Page 23

Peak Elev= 5.14' @ 12.10 hrs

Flood Elev= 10.90'

Device	Routing	Invert	Outlet Devices
#1	Primary	3.60'	24.0" Round Culvert L= 37.0' Ke= 0.500 Inlet / Outlet Invert= 3.60' / 3.40' S= 0.0054 '/ Cc= 0.900 n= 0.013, Flow Area= 3.14 sf

Primary OutFlow Max=8.36 cfs @ 12.10 hrs HW=5.14' TW=0.00' (Dynamic Tailwater)

↑1=Culvert (Barrel Controls 8.36 cfs @ 4.44 fps)

Summary for Pond PDMH4:

[80] Warning: Exceeded Pond JF-2 by 0.17' @ 12.05 hrs (2.44 cfs 0.010 af)

Inflow Area = 4.685 ac, 75.09% Impervious, Inflow Depth > 4.75" for 10-YR event
 Inflow = 24.50 cfs @ 12.07 hrs, Volume= 1.856 af
 Outflow = 24.50 cfs @ 12.07 hrs, Volume= 1.856 af, Atten= 0%, Lag= 0.0 min
 Primary = 24.50 cfs @ 12.07 hrs, Volume= 1.856 af

Routing by Dyn-Stor-Ind method, Time Span= 0.00-24.00 hrs, dt= 0.05 hrs

Peak Elev= 6.85' @ 12.07 hrs

Flood Elev= 10.50'

Device	Routing	Invert	Outlet Devices
#1	Primary	3.30'	24.0" Round Culvert L= 11.0' Ke= 0.500 Inlet / Outlet Invert= 3.30' / 3.25' S= 0.0045 '/ Cc= 0.900 n= 0.013, Flow Area= 3.14 sf

Primary OutFlow Max=23.60 cfs @ 12.07 hrs HW=6.73' TW=0.00' (Dynamic Tailwater)

↑1=Culvert (Inlet Controls 23.60 cfs @ 7.51 fps)

Summary for Pond POND-4.0: UNDERGROUND DETENTION

Inflow Area = 2.220 ac, 66.72% Impervious, Inflow Depth > 4.13" for 10-YR event
 Inflow = 10.56 cfs @ 12.07 hrs, Volume= 0.765 af
 Outflow = 7.84 cfs @ 12.10 hrs, Volume= 0.640 af, Atten= 26%, Lag= 1.6 min
 Primary = 7.84 cfs @ 12.10 hrs, Volume= 0.640 af

Routing by Dyn-Stor-Ind method, Time Span= 0.00-24.00 hrs, dt= 0.05 hrs

Peak Elev= 7.53' @ 12.17 hrs Surf.Area= 6,657 sf Storage= 8,869 cf

Flood Elev= 9.60' Surf.Area= 6,657 sf Storage= 16,172 cf

Plug-Flow detention time= (not calculated: outflow precedes inflow)

Center-of-Mass det. time= 39.4 min (835.2 - 795.8)

C0960-006 POST

Type III 24-hr 10-YR Rainfall=5.60"

Prepared by Tighe & Bond

Printed 2/9/2021

HydroCAD® 10.00-20 s/n 03436 © 2017 HydroCAD Software Solutions LLC

Page 24

Volume	Invert	Avail.Storage	Storage Description
#1A	4.10'	0 cf	31.09'W x 214.17'L x 6.58'H Field A 43,832 cf Overall - 19,624 cf Embedded = 24,208 cf x 0.0% Voids
#2A	4.60'	16,524 cf	ADS N-12 60" x 40 Inside #1 Inside= 59.5"W x 59.5"H => 19.30 sf x 20.00'L = 386.0 cf Outside= 67.0"W x 67.0"H => 22.91 sf x 20.00'L = 458.2 cf 4 Rows of 10 Chambers 28.09' Header x 19.30 sf x 2 = 1,084.1 cf Inside
		16,524 cf	Total Available Storage

Storage Group A created with Chamber Wizard

Device	Routing	Invert	Outlet Devices
#1	Primary	4.60'	18.0" Round Culvert L= 20.0' CPP, projecting, no headwall, Ke= 0.900 Inlet / Outlet Invert= 4.60' / 4.50' S= 0.0050 '/ Cc= 0.900 n= 0.013 Corrugated PE, smooth interior, Flow Area= 1.77 sf
#2	Device 1	4.60'	1.5" Vert. Orifice/Grate C= 0.600
#3	Device 1	6.70'	4.0' long x 5.00' rise Sharp-Crested Rectangular Weir 2 End Contraction(s)

Primary OutFlow Max=5.77 cfs @ 12.10 hrs HW=7.45' TW=6.72' (Dynamic Tailwater)

- 1=Culvert (Inlet Controls 5.77 cfs @ 3.26 fps)
- 2=Orifice/Grate (Passes < 0.05 cfs potential flow)
- 3=Sharp-Crested Rectangular Weir (Passes < 8.23 cfs potential flow)

Summary for Pond POND-5.0: POROUS PAVEMENT

Inflow Area = 0.136 ac, 65.31% Impervious, Inflow Depth > 3.92" for 10-YR event
 Inflow = 0.62 cfs @ 12.07 hrs, Volume= 0.044 af
 Outflow = 0.13 cfs @ 12.49 hrs, Volume= 0.027 af, Atten= 78%, Lag= 25.0 min
 Primary = 0.13 cfs @ 12.49 hrs, Volume= 0.027 af

Routing by Dyn-Stor-Ind method, Time Span= 0.00-24.00 hrs, dt= 0.05 hrs
 Peak Elev= 9.10' @ 12.49 hrs Surf.Area= 3,540 sf Storage= 1,021 cf
 Flood Elev= 11.80' Surf.Area= 3,540 sf Storage= 3,108 cf

Plug-Flow detention time= 218.7 min calculated for 0.027 af (60% of inflow)
 Center-of-Mass det. time= 115.4 min (917.3 - 801.9)

Volume	Invert	Avail.Storage	Storage Description	
#1	8.38'	3,108 cf	Custom Stage Data (Prismatic) Listed below (Recalc)	
Elevation (feet)	Surf.Area (sq-ft)	Voids (%)	Inc.Store (cubic-feet)	Cum.Store (cubic-feet)
8.38	3,540	0.0	0	0
9.95	3,540	40.0	2,223	2,223
10.95	3,540	10.0	354	2,577
11.45	3,540	30.0	531	3,108
11.80	3,540	0.0	0	3,108

C0960-006 POST

Type III 24-hr 10-YR Rainfall=5.60"

Prepared by Tighe & Bond

Printed 2/9/2021

HydroCAD® 10.00-20 s/n 03436 © 2017 HydroCAD Software Solutions LLC

Page 25

Device	Routing	Invert	Outlet Devices
#1	Primary	8.88'	6.0" Round Culvert L= 9.0' CPP, square edge headwall, Ke= 0.500 Inlet / Outlet Invert= 8.88' / 8.00' S= 0.0978 '/ Cc= 0.900 n= 0.013 Corrugated PE, smooth interior, Flow Area= 0.20 sf
#2	Device 1	8.88'	6.0" Vert. Underdrain C= 0.600
#3	Device 2	8.38'	10.000 in/hr Filter Media Infiltration over Surface area

Primary OutFlow Max=0.13 cfs @ 12.49 hrs HW=9.10' TW=3.88' (Dynamic Tailwater)↑**1=Culvert** (Controls 0.13 cfs)↑**2=Underdrain** (Orifice Controls 0.13 cfs @ 1.60 fps)↑**3=Filter Media Infiltration** (Passes 0.13 cfs of 0.82 cfs potential flow)**Summary for Pond POND-5.1: POROUS PAVEMENT**

Inflow Area =	0.602 ac, 38.86% Impervious, Inflow Depth > 3.72" for 10-YR event
Inflow =	2.62 cfs @ 12.07 hrs, Volume= 0.186 af
Outflow =	0.72 cfs @ 12.43 hrs, Volume= 0.149 af, Atten= 73%, Lag= 21.5 min
Primary =	0.72 cfs @ 12.43 hrs, Volume= 0.149 af

Routing by Dyn-Stor-Ind method, Time Span= 0.00-24.00 hrs, dt= 0.05 hrs

Peak Elev= 9.71' @ 12.43 hrs Surf.Area= 6,754 sf Storage= 3,586 cf

Flood Elev= 11.80' Surf.Area= 6,754 sf Storage= 5,930 cf

Plug-Flow detention time= 152.3 min calculated for 0.149 af (80% of inflow)

Center-of-Mass det. time= 76.6 min (884.2 - 807.6)

Volume	Invert	Avail.Storage	Storage Description	
#1	8.38'	5,930 cf	Custom Stage Data (Prismatic) Listed below (Recalc)	
Elevation (feet)	Surf.Area (sq-ft)	Voids (%)	Inc.Store (cubic-feet)	Cum.Store (cubic-feet)
8.38	6,754	0.0	0	0
9.95	6,754	40.0	4,242	4,242
10.95	6,754	10.0	675	4,917
11.45	6,754	30.0	1,013	5,930
11.80	6,754	0.0	0	5,930

Device	Routing	Invert	Outlet Devices
#1	Primary	8.88'	6.0" Round Culvert L= 47.0' CPP, square edge headwall, Ke= 0.500 Inlet / Outlet Invert= 8.88' / 8.00' S= 0.0187 '/ Cc= 0.900 n= 0.013 Corrugated PE, smooth interior, Flow Area= 0.20 sf
#2	Device 1	8.88'	6.0" Vert. Underdrain C= 0.600
#3	Device 2	8.38'	10.000 in/hr Filter Media Infiltration over Surface area

Primary OutFlow Max=0.72 cfs @ 12.43 hrs HW=9.71' TW=4.71' (Dynamic Tailwater)↑**1=Culvert** (Controls 0.72 cfs)↑**2=Underdrain** (Orifice Controls 0.72 cfs @ 3.66 fps)↑**3=Filter Media Infiltration** (Passes 0.72 cfs of 1.56 cfs potential flow)

Summary for Pond RG-1: RAIN GARDEN

[87] Warning: Oscillations may require smaller dt or Finer Routing (severity=102)

Inflow Area = 0.089 ac, 0.00% Impervious, Inflow Depth > 2.85" for 10-YR event
 Inflow = 0.30 cfs @ 12.08 hrs, Volume= 0.021 af
 Outflow = 0.03 cfs @ 13.50 hrs, Volume= 0.007 af, Atten= 91%, Lag= 85.3 min
 Primary = 0.03 cfs @ 13.50 hrs, Volume= 0.007 af

Routing by Dyn-Stor-Ind method, Time Span= 0.00-24.00 hrs, dt= 0.05 hrs
 Peak Elev= 10.00' @ 13.50 hrs Surf.Area= 919 sf Storage= 597 cf
 Flood Elev= 11.80' Surf.Area= 1,590 sf Storage= 2,835 cf

Plug-Flow detention time= 322.2 min calculated for 0.007 af (35% of inflow)
 Center-of-Mass det. time= 195.3 min (1,026.0 - 830.6)

Volume	Invert	Avail.Storage	Storage Description	
#1	7.25'	2,835 cf	Custom Stage Data (Prismatic) Listed below (Recalc)	
Elevation (feet)	Surf.Area (sq-ft)	Voids (%)	Inc.Store (cubic-feet)	Cum.Store (cubic-feet)
7.25	919	0.0	0	0
8.50	919	40.0	460	460
10.00	919	10.0	138	597
11.00	1,269	100.0	1,094	1,691
11.80	1,590	100.0	1,144	2,835

Device	Routing	Invert	Outlet Devices
#1	Primary	7.15'	12.0" Round Culvert L= 238.0' CPP, square edge headwall, Ke= 0.500 Inlet / Outlet Invert= 7.15' / 5.00' S= 0.0090 '/ Cc= 0.900 n= 0.013 Corrugated PE, smooth interior, Flow Area= 0.79 sf
#2	Device 1	10.50'	16.4" x 16.4" Horiz. Orifice/Grate C= 0.600 Limited to weir flow at low heads
#3	Device 1	7.25'	6.0" Vert. UD C= 0.600
#4	Device 3	10.00'	0.26 cfs Exfiltration when above 10.00'

Primary OutFlow Max=0.00 cfs @ 13.50 hrs HW=10.00' TW=4.12' (Dynamic Tailwater)

- ↑ **1=Culvert** (Passes 0.00 cfs of 4.21 cfs potential flow)
- ↑ **2=Orifice/Grate** (Controls 0.00 cfs)
- ↑ **3=UD** (Passes 0.00 cfs of 1.49 cfs potential flow)
- ↑ **4=Exfiltration** (Controls 0.00 cfs)

Summary for Link PA-1:

Inflow Area = 10.853 ac, 56.49% Impervious, Inflow Depth > 3.69" for 10-YR event
 Inflow = 40.92 cfs @ 12.08 hrs, Volume= 3.333 af
 Primary = 40.92 cfs @ 12.08 hrs, Volume= 3.333 af, Atten= 0%, Lag= 0.0 min

Primary outflow = Inflow, Time Span= 0.00-24.00 hrs, dt= 0.05 hrs

C0960-006 POST

Prepared by Tighe & Bond

HydroCAD® 10.00-20 s/n 03436 © 2017 HydroCAD Software Solutions LLC

Type III 24-hr 25-YR Rainfall=7.10"

Printed 2/9/2021

Page 27

Time span=0.00-24.00 hrs, dt=0.05 hrs, 481 points
 Runoff by SCS TR-20 method, UH=SCS, Weighted-CN
 Reach routing by Dyn-Stor-Ind method - Pond routing by Dyn-Stor-Ind method

Subcatchment POST-1.0:	Runoff Area=129,041 sf 66.78% Impervious Runoff Depth>6.03" Tc=5.0 min CN=91 Runoff=19.73 cfs 1.490 af
Subcatchment POST-1.1:	Runoff Area=42,709 sf 91.75% Impervious Runoff Depth>6.62" Tc=5.0 min CN=96 Runoff=6.81 cfs 0.541 af
Subcatchment POST-2.0:	Runoff Area=32,330 sf 86.24% Impervious Runoff Depth>6.50" Tc=5.0 min CN=95 Runoff=5.13 cfs 0.402 af
Subcatchment POST-3.0:	Runoff Area=50,366 sf 70.02% Impervious Runoff Depth>5.80" Tc=5.0 min CN=89 Runoff=7.52 cfs 0.559 af
Subcatchment POST-4.0:	Runoff Area=96,700 sf 66.72% Impervious Runoff Depth>5.57" Tc=5.0 min CN=87 Runoff=14.03 cfs 1.031 af
Subcatchment POST-5.0:	Runoff Area=5,912 sf 65.31% Impervious Runoff Depth>5.35" Tc=5.0 min CN=85 Runoff=0.83 cfs 0.060 af
Subcatchment POST-5.1:	Runoff Area=26,210 sf 38.86% Impervious Runoff Depth>5.12" Tc=5.0 min CN=83 Runoff=3.56 cfs 0.257 af
Subcatchment POST-6.0:	Runoff Area=85,650 sf 0.00% Impervious Runoff Depth>2.38" Tc=5.0 min CN=57 Runoff=5.27 cfs 0.390 af
Subcatchment POST-7.0:	Runoff Area=3,857 sf 0.00% Impervious Runoff Depth>4.13" Tc=5.0 min CN=74 Runoff=0.43 cfs 0.030 af
Pond JF-1:	Peak Elev=11.23' Inflow=26.54 cfs 2.030 af 24.0" Round Culvert n=0.013 L=4.0' S=0.0125 '/' Outflow=26.54 cfs 2.030 af
Pond JF-2:	Peak Elev=9.23' Inflow=5.13 cfs 0.402 af 15.0" Round Culvert n=0.013 L=50.0' S=0.0040 '/' Outflow=5.13 cfs 0.402 af
Pond JF-3:	Peak Elev=5.03' Inflow=7.62 cfs 0.602 af 18.0" Round Culvert n=0.013 L=5.0' S=0.0200 '/' Outflow=7.62 cfs 0.602 af
Pond JF-4:	Peak Elev=6.97' Inflow=8.19 cfs 0.905 af 15.0" Round Culvert n=0.013 L=55.0' S=0.0055 '/' Outflow=8.19 cfs 0.905 af
Pond PDMH10:	Peak Elev=5.22' Inflow=9.02 cfs 1.141 af 24.0" Round Culvert n=0.013 L=37.0' S=0.0054 '/' Outflow=9.02 cfs 1.141 af
Pond PDMH4:	Peak Elev=8.63' Inflow=31.67 cfs 2.433 af 24.0" Round Culvert n=0.013 L=11.0' S=0.0045 '/' Outflow=31.67 cfs 2.433 af
Pond POND-4.0: UNDERGROUND	Peak Elev=8.01' Storage=10,847 cf Inflow=14.03 cfs 1.031 af Outflow=8.19 cfs 0.905 af

C0960-006 POST

Prepared by Tighe & Bond

HydroCAD® 10.00-20 s/n 03436 © 2017 HydroCAD Software Solutions LLC

Type III 24-hr 25-YR Rainfall=7.10"

Printed 2/9/2021

Page 28

Pond POND-5.0: POROUS PAVEMENT Peak Elev=9.24' Storage=1,216 cf Inflow=0.83 cfs 0.060 af
Outflow=0.31 cfs 0.042 af

Pond POND-5.1: POROUS PAVEMENT Peak Elev=10.73' Storage=4,768 cf Inflow=3.56 cfs 0.257 af
Outflow=1.03 cfs 0.219 af

Pond RG-1: RAIN GARDEN Peak Elev=10.01' Storage=605 cf Inflow=0.43 cfs 0.030 af
Outflow=0.27 cfs 0.017 af

Link PA-1: Inflow=52.93 cfs 4.565 af
Primary=52.93 cfs 4.565 af

Total Runoff Area = 10.853 ac Runoff Volume = 4.760 af Average Runoff Depth = 5.26"
43.51% Pervious = 4.722 ac 56.49% Impervious = 6.131 ac

C0960-006 POST

Prepared by Tighe & Bond

HydroCAD® 10.00-20 s/n 03436 © 2017 HydroCAD Software Solutions LLC

Type III 24-hr 50-YR Rainfall=8.50"

Printed 2/9/2021

Page 29

Time span=0.00-24.00 hrs, dt=0.05 hrs, 481 points
 Runoff by SCS TR-20 method, UH=SCS, Weighted-CN
 Reach routing by Dyn-Stor-Ind method - Pond routing by Dyn-Stor-Ind method

Subcatchment POST-1.0:	Runoff Area=129,041 sf 66.78% Impervious Runoff Depth>7.41" Tc=5.0 min CN=91 Runoff=23.96 cfs 1.830 af
Subcatchment POST-1.1:	Runoff Area=42,709 sf 91.75% Impervious Runoff Depth>8.02" Tc=5.0 min CN=96 Runoff=8.19 cfs 0.655 af
Subcatchment POST-2.0:	Runoff Area=32,330 sf 86.24% Impervious Runoff Depth>7.90" Tc=5.0 min CN=95 Runoff=6.17 cfs 0.488 af
Subcatchment POST-3.0:	Runoff Area=50,366 sf 70.02% Impervious Runoff Depth>7.17" Tc=5.0 min CN=89 Runoff=9.18 cfs 0.691 af
Subcatchment POST-4.0:	Runoff Area=96,700 sf 66.72% Impervious Runoff Depth>6.93" Tc=5.0 min CN=87 Runoff=17.25 cfs 1.283 af
Subcatchment POST-5.0:	Runoff Area=5,912 sf 65.31% Impervious Runoff Depth>6.69" Tc=5.0 min CN=85 Runoff=1.03 cfs 0.076 af
Subcatchment POST-5.1:	Runoff Area=26,210 sf 38.86% Impervious Runoff Depth>6.45" Tc=5.0 min CN=83 Runoff=4.44 cfs 0.324 af
Subcatchment POST-6.0:	Runoff Area=85,650 sf 0.00% Impervious Runoff Depth>3.36" Tc=5.0 min CN=57 Runoff=7.62 cfs 0.551 af
Subcatchment POST-7.0:	Runoff Area=3,857 sf 0.00% Impervious Runoff Depth>5.37" Tc=5.0 min CN=74 Runoff=0.56 cfs 0.040 af
Pond JF-1:	Peak Elev=14.45' Inflow=32.14 cfs 2.485 af 24.0" Round Culvert n=0.013 L=4.0' S=0.0125 '/' Outflow=32.14 cfs 2.485 af
Pond JF-2:	Peak Elev=11.52' Inflow=6.17 cfs 0.488 af 15.0" Round Culvert n=0.013 L=50.0' S=0.0040 '/' Outflow=6.17 cfs 0.488 af
Pond JF-3:	Peak Elev=5.43' Inflow=9.48 cfs 0.749 af 18.0" Round Culvert n=0.013 L=5.0' S=0.0200 '/' Outflow=9.48 cfs 0.749 af
Pond JF-4:	Peak Elev=7.30' Inflow=8.61 cfs 1.156 af 15.0" Round Culvert n=0.013 L=55.0' S=0.0055 '/' Outflow=8.61 cfs 1.156 af
Pond PDMH10:	Peak Elev=5.32' Inflow=9.97 cfs 1.467 af 24.0" Round Culvert n=0.013 L=37.0' S=0.0054 '/' Outflow=9.97 cfs 1.467 af
Pond PDMH4:	Peak Elev=10.65' Inflow=38.31 cfs 2.974 af 24.0" Round Culvert n=0.013 L=11.0' S=0.0045 '/' Outflow=38.31 cfs 2.974 af
Pond POND-4.0: UNDERGROUND	Peak Elev=8.54' Storage=12,968 cf Inflow=17.25 cfs 1.283 af Outflow=8.61 cfs 1.156 af

C0960-006 POST

Prepared by Tighe & Bond

HydroCAD® 10.00-20 s/n 03436 © 2017 HydroCAD Software Solutions LLC

Type III 24-hr 50-YR Rainfall=8.50"

Printed 2/9/2021

Page 30

Pond POND-5.0: POROUS PAVEMENT Peak Elev=9.37' Storage=1,396 cf Inflow=1.03 cfs 0.076 af
Outflow=0.46 cfs 0.058 af

Pond POND-5.1: POROUS PAVEMENT Peak Elev=11.41' Storage=5,851 cf Inflow=4.44 cfs 0.324 af
Outflow=1.18 cfs 0.285 af



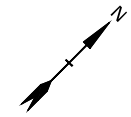

Pond RG-1: RAIN GARDEN Peak Elev=10.06' Storage=656 cf Inflow=0.56 cfs 0.040 af
Outflow=0.26 cfs 0.026 af

Link PA-1: Inflow=64.15 cfs 5.740 af
Primary=64.15 cfs 5.740 af

Total Runoff Area = 10.853 ac Runoff Volume = 5.937 af Average Runoff Depth = 6.56"
43.51% Pervious = 4.722 ac 56.49% Impervious = 6.131 ac

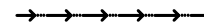

LEGEND

-  POST-DEVELOPMENT WATERSHED BOUNDARY
-  LONGEST FLOW PATH
-  PRE DEVELOPMENT WATERSHED AREA DESIGNATION
-  POST-DEVELOPMENT POND DESIGNATION
-  POINT OF ANALYSIS

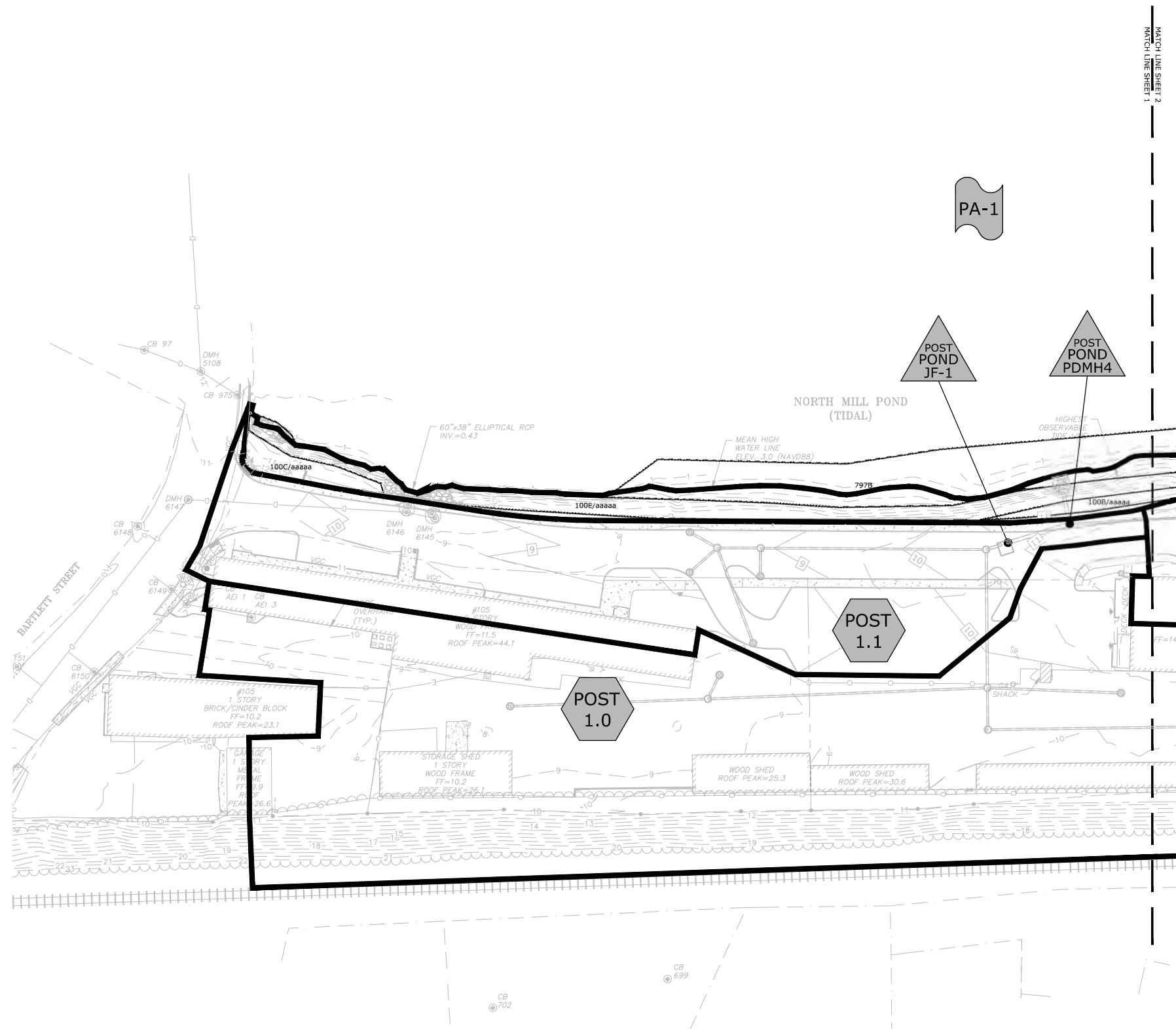
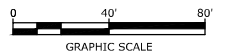

Proposed Multi-Family Development

Iron Horse Properties, LLC

105 Bartlett Street
Portsmouth,
New Hampshire

MARK	DATE	DESCRIPTION
I	2/11/2021	PB Submission
H	1/20/2021	TAC Resubmission
G	11/18/2020	TAC Resubmission
F	10/28/2020	Wetland CUP Resubmission
E	5/20/2020	TAC Resubmission
D	4/29/2020	Wetland CUP Submission
C	4/20/2020	TAC Submission
B	2/6/2020	Design Review Submission
A	1/2/2020	ZBA Submission

PROJECT NO:	C-0960-006
DATE:	April 20, 2020
FILE:	C-0960-006_C-SITE.DWG
DRAWN BY:	NAH
CHECKED BY:	PMC
APPROVED BY:	BML



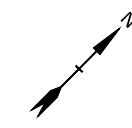

POST-DEVELOPMENT WATERSHED PLAN

SCALE: AS SHOWN

C-802.1



LEGEND

-  POST-DEVELOPMENT WATERSHED BOUNDARY
-  LONGEST FLOW PATH
-  POST 1.0
PRE DEVELOPMENT WATERSHED AREA DESIGNATION
-  POST POND 1
POST-DEVELOPMENT POND DESIGNATION
-  PA-1
POINT OF ANALYSIS

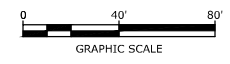
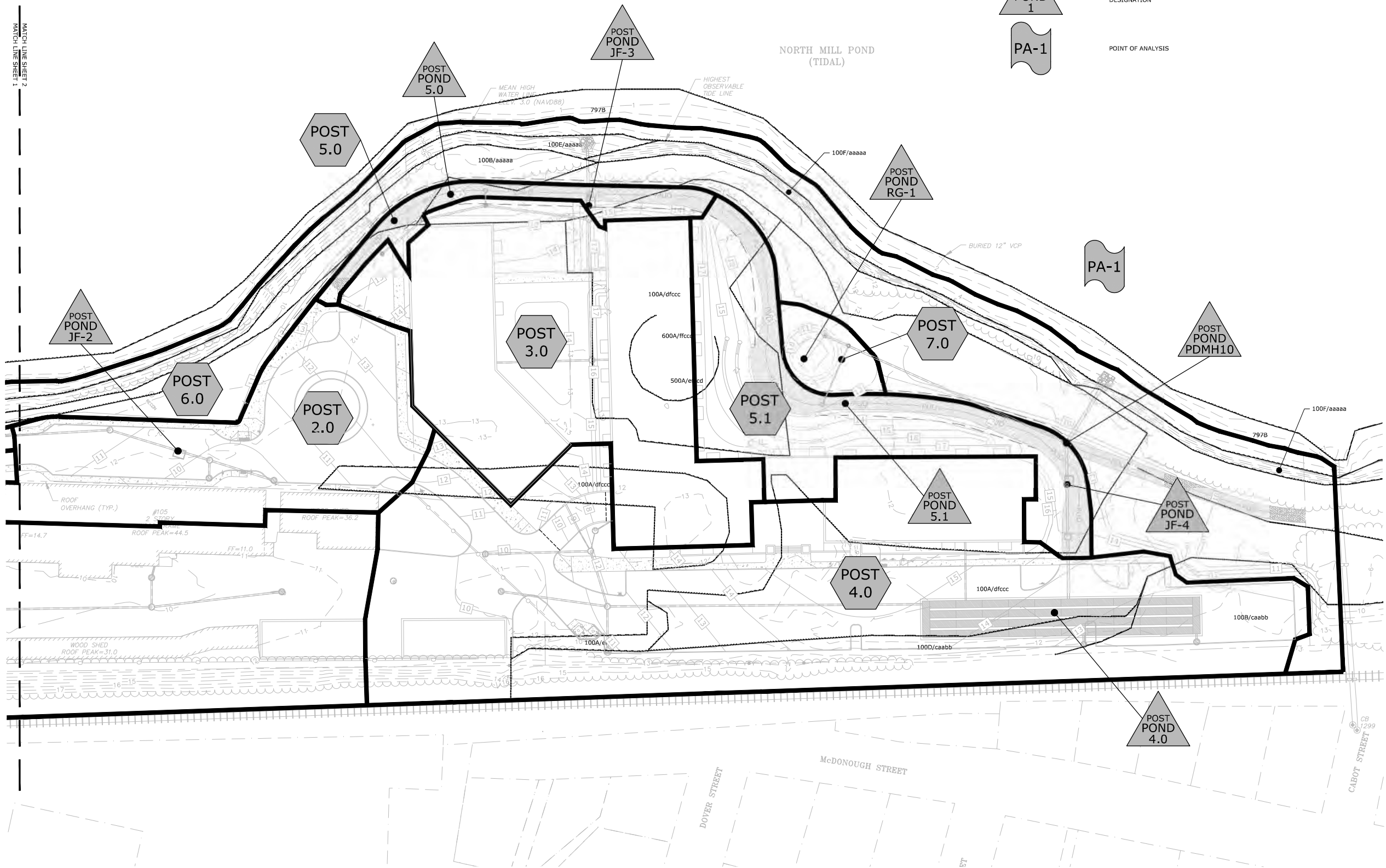

Proposed Multi-Family Development

Iron Horse Properties, LLC

105 Bartlett Street
Portsmouth,
New Hampshire

MARK	DATE	DESCRIPTION
I	2/11/2021	PB Submission
H	1/20/2021	TAC Resubmission
G	11/18/2020	TAC Resubmission
F	10/28/2020	Wetland CUP Resubmission
E	5/20/2020	TAC Resubmission
D	4/29/2020	Wetland CUP Submission
C	4/20/2020	TAC Submission
B	2/6/2020	Design Review Submission
A	1/2/2020	ZBA Submission

PROJECT NO:	C-0960-006
DATE:	April 20, 2020
FILE:	C-0960-006_C-SITE.DWG
DRAWN BY:	NAH
CHECKED:	PMC
APPROVED:	BML

POST-DEVELOPMENT WATERSHED PLAN

SCALE: AS SHOWN

C-802.2

Last Saved: 2/18/2021
 Plotted On: Feb 08, 2021 - 3:03pm By: MAHnenen
 Tighe & Bond: C:\Users\MAHnenen\OneDrive\Documents\CAD\Drawings - Figures\AutoCAD\Sheet\C-0960-006_C-SITE.dwg

Section 4

Stormwater Treatment

The stormwater management system has been designed to provide stormwater treatment as required by the City of Portsmouth Site Review Regulations and NHDES AoT Regulations (Env-Wq 1500).

4.4.1 Pre-Treatment Methods for Protecting Water Quality

Pre-treatment for the stormwater filtration systems consist of deep sump catch basins.

4.4.2 Treatment Methods for Protecting Water Quality.

The runoff from existing and proposed impervious areas will be treated by various Contech Jellyfish stormwater filtration systems. These Jellyfish systems are sized to treat the Water Quality Flows of their respective subcatchment areas. Each system is outfitted with an internal bypass that diverts peak flows away from treatment. The BMP worksheet for these treatment practices have been included in Section 5 of this report.

A rain garden within the proposed greenway park is included to treat runoff from the surrounding area. The rain garden has been designed and sized to contain the 50-year storm without overtopping, as well as treat a volume of runoff greater than the WQV. Due to poor infiltration rates of the surrounding soils, the bottom of the rain garden is proposed to be lined and outfitted with underdrains to convey treated runoff to the system's outlet structure. The BMP worksheet for this treatment practice has been included in Section 5 of this report, as well.

The multiuse path along the North Mill Pond and through the greenway park will be constructed as lined porous pavement with and underdrain. The underdrain will discharge to the onsite closed drainage system prior to discharging to the Pond.

BMP	Total Suspended Solids	Total Nitrogen	Total Phosphorus
Jellyfish Filter w/Pretreatment ¹	91%	53%	61%
Raingarden ²	90%	65%	65%
Porous Pavement w/Underdrain ²	90%	10%	45%

1. Pollutant removal calculations for Jellyfish Filter with deep sump catchbasin pretreatment shown in Table 4.2.
2. Pollutant removal efficiencies from NH Stormwater Manual Volume 2, Appendix B.

Table 4.2 – Pollutant Removal Calculations				
Contech Jellyfish Filter				
BMP	TSS Removal Rate	Starting TSS Load	TSS Removed	Remaining TSS Load
Deep Sump Catchbasin w/Hood ¹	0.15	1.00	0.15	0.85
Jellyfish Filter ²	0.89	0.85	0.76	0.09
Total Suspended Solids Removed:				91%
	TN Removal Rate	Starting TN Load	TN Removed	Remaining TN Load
Deep Sump Catchbasin w/Hood ¹	0.05	1.00	0.05	0.95
Jellyfish Filter ²	0.51	0.95	0.48	0.47
Total Nitrogen Removed:				53%
	TP Removal Rate	Starting TP Load	TP Removed	Remaining TP Load
Deep Sump Catchbasin w/Hood ¹	0.05	1.00	0.05	0.95
Jellyfish Filter ²	0.59	0.95	0.56	0.39
Total Phosphorus Removed:				61%

1. Pollutant removal efficiencies from NH Stormwater Manual Volume 2, Appendix E.
2. Pollutant removal efficiencies from Contech Engineered Solutions, Jellyfish Filter Stormwater Treatment performance testing results.

Section 5

BMP Worksheets and Sizing Memos



CONTECH Stormwater Solutions Inc. Engineer:
Date Prepared:

DRA
11/13/2020

Site Information

Project Name	105 Bartlett Street JF1
Project State	NH
Project City	Portsmouth
Total Drainage Area, Ad	3.94 ac
Post Development Impervious Area, Ai	2.88 ac
Pervious Area, Ap	1.06 ac
% Impervious	73%
Runoff Coefficient, Rc	0.71

Mass Loading Calculations

Mean Annual Rainfall, P	50 in
Agency Required % Removal	80%
Percent Runoff Capture	90%
Mean Annual Runoff, Vt	455583 ft ³
Event Mean Concentration of Pollutant, EMC	70 mg/l
Annual Mass Load, M total	1989.70 lbs

Filter System

Filtration Brand	Jelly Fish
Cartridge Length	54 in

Jelly Fish Sizing

Mass to be Captured by System	1591.76 lbs
Water Quality Flow	2.85 cfs

Method to Use

FLOW BASED

Summary

Flow	Treatment Flow Rate	2.94 cfs
	Required Size	JFPD0808-15-3



CONTECH Stormwater Solutions Inc. Engineer:
Date Prepared:

DRA
11/13/2020

Site Information

Project Name	105 Bartlett Street JF2
Project State	NH
Project City	Portsmouth
Total Drainage Area, Ad	0.74 ac
Post Development Impervious Area, Ai	0.64 ac
Pervious Area, Ap	0.10 ac
% Impervious	86%
Runoff Coefficient, Rc	0.83

Mass Loading Calculations

Mean Annual Rainfall, P	50 in
Agency Required % Removal	80%
Percent Runoff Capture	90%
Mean Annual Runoff, Vt	98663 ft ³
Event Mean Concentration of Pollutant, EMC	70 mg/l
Annual Mass Load, M total	430.90 lbs

Filter System

Filtration Brand	Jelly Fish
Cartridge Length	40 in

Jelly Fish Sizing

Mass to be Captured by System	344.72 lbs
Water Quality Flow	0.63 cfs

Method to Use

FLOW BASED

Summary

Flow	Treatment Flow Rate	0.73 cfs
	Required Size	JFPD0806-5-1



CONTECH Stormwater Solutions Inc. Engineer:
Date Prepared:

DRA
11/13/2020

Site Information

Project Name	105 Bartlett Street JF3
Project State	NH
Project City	Portsmouth
Total Drainage Area, Ad	1.29 ac
Post Development Impervious Area, Ai	0.90 ac
Pervious Area, Ap	0.39 ac
% Impervious	70%
Runoff Coefficient, Rc	0.68

Mass Loading Calculations

Mean Annual Rainfall, P	50 in
Agency Required % Removal	80%
Percent Runoff Capture	90%
Mean Annual Runoff, Vt	158450 ft ³
Event Mean Concentration of Pollutant, EMC	70 mg/l
Annual Mass Load, M total	692.01 lbs

Filter System

Filtration Brand	Jelly Fish
Cartridge Length	54 in

Jelly Fish Sizing

Mass to be Captured by System	553.60 lbs
Water Quality Flow	0.89 cfs

Method to Use

FLOW BASED

Summary

Flow	Treatment Flow Rate	1.07 cfs
	Required Size	JFPD0806-5-2



CONTECH Stormwater Solutions Inc. Engineer:
Date Prepared:

DRA
11/13/2020

Site Information

Project Name	105 Bartlett Street JF4
Project State	NH
Project City	Portsmouth
Total Drainage Area, Ad	2.22 ac
Post Development Impervious Area, Ai	1.48 ac
Pervious Area, Ap	0.74 ac
% Impervious	67%
Runoff Coefficient, Rc	0.65

Mass Loading Calculations

Mean Annual Rainfall, P	50 in
Agency Required % Removal	80%
Percent Runoff Capture	90%
Mean Annual Runoff, Vt	262422 ft ³
Event Mean Concentration of Pollutant, EMC	70 mg/l
Annual Mass Load, M total	1146.09 lbs

Filter System

Filtration Brand	Jelly Fish
Cartridge Length	54 in

Jelly Fish Sizing

Mass to be Captured by System	916.87 lbs
-------------------------------	------------

Summary

Mass	Treatment Mass	1001.00 lbs
	Required Size	JFPD0806-7-2



FILTRATION PRACTICE DESIGN CRITERIA (Env-Wq 1508.07)

Type/Node Name: _____

RG-1

Enter the type of filtration practice (e.g., bioretention system) and the node name in the drainage analysis, if applicable

Yes		Have you reviewed the restrictions on unlined systems outlined in Env-Wq 1508.07(a)?	
0.09	ac	A = Area draining to the practice	
-	ac	A _I = Impervious area draining to the practice	
-	decimal	I = percent impervious area draining to the practice, in decimal form	
0.05	unitless	R _v = Runoff coefficient = 0.05 + (0.9 x I)	
0.00	ac-in	WQV = 1" x R _v x A	
16	cf	WQV conversion (ac-in x 43,560 sf/ac x 1ft/12")	
4	cf	25% x WQV (check calc for sediment forebay volume)	
12	cf	75% x WQV (check calc for surface sand filter volume)	
Clean		Method of Pretreatment? (not required for clean or roof runoff)	
cf		V _{SED} = sediment forebay volume, if used for pretreatment	← ≥ 25%WQV
919	sf	A _{SA} = surface area of the practice	
-	iph	K _{sat} DESIGN = design infiltration rate ¹	
Yes	Yes/No	If K _{sat} (prior to factor of safety) is < 0.50 iph, has an underdrain been provided?	
-	hours	T _{DRAIN} = drain time = V / (A _{SA} * I _{DESIGN})	← ≤ 72-hrs
8.50	feet	E _{FC} = elevation of the bottom of the filter course material ²	
7.25	feet	E _{UD} = invert elevation of the underdrain (UD), if applicable	
	feet	E _{SHWT} = elevation of SHWT (if none found, enter the lowest elevation of the test pit)	
	feet	E _{ROCK} = elevation of bedrock (if none found, enter the lowest elevation of the test pit)	
1.25	feet	D _{FC to UD} = depth to UD from the bottom of the filter course	← ≥ 1'
8.50	feet	D _{FC to ROCK} = depth to bedrock from the bottom of the filter course	← ≥ 1'
8.50	feet	D _{FC to SHWT} = depth to SHWT from the bottom of the filter course	← ≥ 1'
10.06	ft	Peak elevation of the 50-year storm event (infiltration can be used in analysis)	
11.80	ft	Elevation of the top of the practice	
YES		50 peak elevation ≤ Elevation of the top of the practice	← yes

If a surface sand filter or underground sand filter is proposed:

YES	ac	Drainage Area check.	← < 10 ac
	cf	V = volume of storage ³ (attach a stage-storage table)	← ≥ 75%WQV
	inches	D _{FC} = filter course thickness	← 18", or 24" if within GPA
Sheet		Note what sheet in the plan set contains the filter course specification	
Yes/No		Access grate provided?	← yes

C0960-006 POST

Prepared by Tighe & Bond

HydroCAD® 10.00-20 s/n 03436 © 2017 HydroCAD Software Solutions LLC

Type III 24-hr 50-YR Rainfall=8.50"

Printed 1/18/2021

Stage-Area-Storage for Pond RG-1: RAIN GARDEN

Elevation (feet)	Surface (sq-ft)	Storage (cubic-feet)	Elevation (feet)	Surface (sq-ft)	Storage (cubic-feet)
7.25	919	0	9.85	919	584
7.30	919	18	9.90	919	588
7.35	919	37	9.95	919	593
7.40	919	55	10.00	919	597
7.45	919	74	10.05	937	644
7.50	919	92	10.10	954	691
7.55	919	110	10.15	972	739
7.60	919	129	10.20	989	788
7.65	919	147	10.25	1,007	838
7.70	919	165	10.30	1,024	889
7.75	919	184	10.35	1,041	940
7.80	919	202	10.40	1,059	993
7.85	919	221	10.45	1,076	1,046
7.90	919	239	10.50	1,094	1,101
7.95	919	257	10.55	1,112	1,156
8.00	919	276	10.60	1,129	1,212
8.05	919	294	10.65	1,147	1,269
8.10	919	312	10.70	1,164	1,326
8.15	919	331	10.75	1,182	1,385
8.20	919	349	10.80	1,199	1,445
8.25	919	368	10.85	1,216	1,505
8.30	919	386	10.90	1,234	1,566
8.35	919	404	10.95	1,251	1,628
8.40	919	423	11.00	1,269	1,691
8.45	919	441	11.05	1,289	1,755
8.50	919	460	11.10	1,309	1,820
8.55	919	464	11.15	1,329	1,886
8.60	919	469	11.20	1,349	1,953
8.65	919	473	11.25	1,369	2,021
8.70	919	478	11.30	1,389	2,090
8.75	919	482	11.35	1,409	2,160
8.80	919	487	11.40	1,430	2,231
8.85	919	492	11.45	1,450	2,303
8.90	919	496	11.50	1,470	2,376
8.95	919	501	11.55	1,490	2,450
9.00	919	505	11.60	1,510	2,525
9.05	919	510	11.65	1,530	2,601
9.10	919	515	11.70	1,550	2,678
9.15	919	519	11.75	1,570	2,756
9.20	919	524	11.80	1,590	2,835
9.25	919	528			
9.30	919	533			
9.35	919	538			
9.40	919	542			
9.45	919	547			
9.50	919	551			
9.55	919	556			
9.60	919	561			
9.65	919	565			
9.70	919	570			
9.75	919	574			
9.80	919	579			



FILTRATION PRACTICE DESIGN CRITERIA (Env-Wq 1508.07)

Type/Node Name: _____

PP-1

Enter the type of filtration practice (e.g., bioretention system) and the node name in the drainage analysis, if applicable

Yes		Have you reviewed the restrictions on unlined systems outlined in Env-Wq 1508.07(a)?	
0.14	ac	A = Area draining to the practice	
0.09	ac	A _I = Impervious area draining to the practice	
0.65	decimal	I = percent impervious area draining to the practice, in decimal form	
0.64	unitless	R _v = Runoff coefficient = 0.05 + (0.9 x I)	
0.09	ac-in	WQV = 1" x R _v x A	
315	cf	WQV conversion (ac-in x 43,560 sf/ac x 1ft/12")	
79	cf	25% x WQV (check calc for sediment forebay volume)	
237	cf	75% x WQV (check calc for surface sand filter volume)	
		Method of Pretreatment? (not required for clean or roof runoff)	
	cf	V _{SED} = sediment forebay volume, if used for pretreatment	← ≥ 25%WQV
3,540	sf	A _{SA} = surface area of the practice	
-	iph	K _{sat} DESIGN = design infiltration rate ¹	
Yes	Yes/No	If K _{sat} (prior to factor of safety) is < 0.50 iph, has an underdrain been provided?	
-	hours	T _{DRAIN} = drain time = V / (A _{SA} * I _{DESIGN})	← ≤ 72-hrs
9.95	feet	E _{FC} = elevation of the bottom of the filter course material ²	
8.88	feet	E _{UD} = invert elevation of the underdrain (UD), if applicable	
	feet	E _{SHWT} = elevation of SHWT (if none found, enter the lowest elevation of the test pit)	
	feet	E _{ROCK} = elevation of bedrock (if none found, enter the lowest elevation of the test pit)	
1.07	feet	D _{FC to UD} = depth to UD from the bottom of the filter course	← ≥ 1'
9.95	feet	D _{FC to ROCK} = depth to bedrock from the bottom of the filter course	← ≥ 1'
9.95	feet	D _{FC to SHWT} = depth to SHWT from the bottom of the filter course	← ≥ 1'
9.37	ft	Peak elevation of the 50-year storm event (infiltration can be used in analysis)	
11.80	ft	Elevation of the top of the practice	
YES		50 peak elevation ≤ Elevation of the top of the practice	← yes

If a surface sand filter or underground sand filter is proposed:

YES	ac	Drainage Area check.	← < 10 ac
	cf	V = volume of storage ³ (attach a stage-storage table)	← ≥ 75%WQV
	inches	D _{FC} = filter course thickness	← 18", or 24" if within GPA
Sheet		Note what sheet in the plan set contains the filter course specification	
	Yes/No	Access grate provided?	← yes

If a bioretention area is proposed:

YES	ac	Drainage Area no larger than 5 ac?	← yes
	cf	V = volume of storage ³ (attach a stage-storage table)	← ≥ WQV
	inches	D _{FC} = filter course thickness	← 18", or 24" if within GPA
Sheet		Note what sheet in the plan set contains the filter course specification	
	:1	Pond side slopes	← ≥3:1
Sheet		Note what sheet in the plan set contains the planting plans and surface cover	

If porous pavement is proposed:

Asphalt		Type of pavement proposed (concrete? Asphalt? Pavers? Etc)	
0.1	acres	A _{SA} = surface area of the pervious pavement	
1.7	:1	ratio of the contributing area to the pervious surface area	← ≤ 5:1
12.0	inches	D _{FC} = filter course thickness	← 12", or 18" if within GPA
Sheet	C-504	Note what sheet in the plan set contains the filter course spec.	← 304.1 sand

1. Rate of the limiting layer (either the filter course or the underlying soil). $K_{sat_{design}}$ includes factor of safety. See Env-Wq 1504.14 for guidance on determining the infiltration rate.
2. See lines 34, 40 and 48 for required depths of filter media.
3. Volume without depending on infiltration. The volume includes the storage above the filter (but below the invert of the outlet structure, if any), the filter media voids, and the pretreatment area. The storage above the filter media shall not include the volume above the outlet structure, if any.

Designer's Notes:

C0960-006 POST

Prepared by Tighe & Bond

HydroCAD® 10.00-20 s/n 03436 © 2017 HydroCAD Software Solutions LLC

Type III 24-hr 25-YR Rainfall=7.10"

Printed 1/18/2021

Stage-Area-Storage for Pond POND-5.0: POROUS PAVEMENT

Elevation (feet)	Surface (sq-ft)	Storage (cubic-feet)	Elevation (feet)	Surface (sq-ft)	Storage (cubic-feet)
8.38	3,540	0	10.98	3,540	2,609
8.43	3,540	71	11.03	3,540	2,662
8.48	3,540	142	11.08	3,540	2,715
8.53	3,540	212	11.13	3,540	2,768
8.58	3,540	283	11.18	3,540	2,821
8.63	3,540	354	11.23	3,540	2,874
8.68	3,540	425	11.28	3,540	2,928
8.73	3,540	496	11.33	3,540	2,981
8.78	3,540	566	11.38	3,540	3,034
8.83	3,540	637	11.43	3,540	3,087
8.88	3,540	708	11.48	3,540	3,108
8.93	3,540	779	11.53	3,540	3,108
8.98	3,540	850	11.58	3,540	3,108
9.03	3,540	920	11.63	3,540	3,108
9.08	3,540	991	11.68	3,540	3,108
9.13	3,540	1,062	11.73	3,540	3,108
9.18	3,540	1,133	11.78	3,540	3,108
9.23	3,540	1,204			
9.28	3,540	1,274			
9.33	3,540	1,345			
9.38	3,540	1,416			
9.43	3,540	1,487			
9.48	3,540	1,558			
9.53	3,540	1,628			
9.58	3,540	1,699			
9.63	3,540	1,770			
9.68	3,540	1,841			
9.73	3,540	1,912			
9.78	3,540	1,982			
9.83	3,540	2,053			
9.88	3,540	2,124			
9.93	3,540	2,195			
9.98	3,540	2,234			
10.03	3,540	2,251			
10.08	3,540	2,269			
10.13	3,540	2,287			
10.18	3,540	2,305			
10.23	3,540	2,322			
10.28	3,540	2,340			
10.33	3,540	2,358			
10.38	3,540	2,375			
10.43	3,540	2,393			
10.48	3,540	2,411			
10.53	3,540	2,428			
10.58	3,540	2,446			
10.63	3,540	2,464			
10.68	3,540	2,482			
10.73	3,540	2,499			
10.78	3,540	2,517			
10.83	3,540	2,535			
10.88	3,540	2,552			
10.93	3,540	2,570			



FILTRATION PRACTICE DESIGN CRITERIA (Env-Wq 1508.07)

Type/Node Name: _____

PP-2

Enter the type of filtration practice (e.g., bioretention system) and the node name in the drainage analysis, if applicable

Yes		Have you reviewed the restrictions on unlined systems outlined in Env-Wq 1508.07(a)?	
0.60	ac	A = Area draining to the practice	
0.23	ac	A _I = Impervious area draining to the practice	
0.39	decimal	I = percent impervious area draining to the practice, in decimal form	
0.40	unitless	R _v = Runoff coefficient = 0.05 + (0.9 x I)	
0.24	ac-in	WQV = 1" x R _v x A	
874	cf	WQV conversion (ac-in x 43,560 sf/ac x 1ft/12")	
218	cf	25% x WQV (check calc for sediment forebay volume)	
655	cf	75% x WQV (check calc for surface sand filter volume)	
		Method of Pretreatment? (not required for clean or roof runoff)	
	cf	V _{SED} = sediment forebay volume, if used for pretreatment	← ≥ 25%WQV
6,754	sf	A _{SA} = surface area of the practice	
-	iph	K _{satDESIGN} = design infiltration rate ¹	
Yes	Yes/No	If K _{sat} (prior to factor of safety) is < 0.50 iph, has an underdrain been provided?	
-	hours	T _{DRAIN} = drain time = V / (A _{SA} * I _{DESIGN})	← ≤ 72-hrs
9.95	feet	E _{FC} = elevation of the bottom of the filter course material ²	
8.88	feet	E _{UD} = invert elevation of the underdrain (UD), if applicable	
	feet	E _{SHWT} = elevation of SHWT (if none found, enter the lowest elevation of the test pit)	
	feet	E _{ROCK} = elevation of bedrock (if none found, enter the lowest elevation of the test pit)	
1.07	feet	D _{FC to UD} = depth to UD from the bottom of the filter course	← ≥ 1'
9.95	feet	D _{FC to ROCK} = depth to bedrock from the bottom of the filter course	← ≥ 1'
9.95	feet	D _{FC to SHWT} = depth to SHWT from the bottom of the filter course	← ≥ 1'
11.41	ft	Peak elevation of the 50-year storm event (infiltration can be used in analysis)	
11.80	ft	Elevation of the top of the practice	
YES		50 peak elevation ≤ Elevation of the top of the practice	← yes

If a surface sand filter or underground sand filter is proposed:

YES	ac	Drainage Area check.	← < 10 ac
	cf	V = volume of storage ³ (attach a stage-storage table)	← ≥ 75%WQV
	inches	D _{FC} = filter course thickness	← 18", or 24" if within GPA
Sheet		Note what sheet in the plan set contains the filter course specification	
	Yes/No	Access grate provided?	← yes

C0960-006 POST

Prepared by Tighe & Bond

HydroCAD® 10.00-20 s/n 03436 © 2017 HydroCAD Software Solutions LLC

Type III 24-hr 25-YR Rainfall=7.10"

Printed 1/18/2021

Stage-Area-Storage for Pond POND-5.1: POROUS PAVEMENT

Elevation (feet)	Surface (sq-ft)	Storage (cubic-feet)	Elevation (feet)	Surface (sq-ft)	Storage (cubic-feet)
8.38	6,754	0	10.98	6,754	4,978
8.43	6,754	135	11.03	6,754	5,079
8.48	6,754	270	11.08	6,754	5,180
8.53	6,754	405	11.13	6,754	5,282
8.58	6,754	540	11.18	6,754	5,383
8.63	6,754	675	11.23	6,754	5,484
8.68	6,754	810	11.28	6,754	5,586
8.73	6,754	946	11.33	6,754	5,687
8.78	6,754	1,081	11.38	6,754	5,788
8.83	6,754	1,216	11.43	6,754	5,889
8.88	6,754	1,351	11.48	6,754	5,930
8.93	6,754	1,486	11.53	6,754	5,930
8.98	6,754	1,621	11.58	6,754	5,930
9.03	6,754	1,756	11.63	6,754	5,930
9.08	6,754	1,891	11.68	6,754	5,930
9.13	6,754	2,026	11.73	6,754	5,930
9.18	6,754	2,161	11.78	6,754	5,930
9.23	6,754	2,296			
9.28	6,754	2,431			
9.33	6,754	2,567			
9.38	6,754	2,702			
9.43	6,754	2,837			
9.48	6,754	2,972			
9.53	6,754	3,107			
9.58	6,754	3,242			
9.63	6,754	3,377			
9.68	6,754	3,512			
9.73	6,754	3,647			
9.78	6,754	3,782			
9.83	6,754	3,917			
9.88	6,754	4,052			
9.93	6,754	4,187			
9.98	6,754	4,262			
10.03	6,754	4,296			
10.08	6,754	4,329			
10.13	6,754	4,363			
10.18	6,754	4,397			
10.23	6,754	4,431			
10.28	6,754	4,464			
10.33	6,754	4,498			
10.38	6,754	4,532			
10.43	6,754	4,566			
10.48	6,754	4,599			
10.53	6,754	4,633			
10.58	6,754	4,667			
10.63	6,754	4,701			
10.68	6,754	4,735			
10.73	6,754	4,768			
10.78	6,754	4,802			
10.83	6,754	4,836			
10.88	6,754	4,870			
10.93	6,754	4,903			

Section 6 Long-Term Operation & Maintenance Plan

It is the intent of this Operation and Maintenance Plan to identify the areas of this site that need special attention and consideration, as well as implementing a plan to assure routine maintenance. By identifying the areas of concern as well as implementing a frequent and routine maintenance schedule the site will maintain a high-quality stormwater runoff.

6.1 Contact/Responsible Party

Tax Map & Lot	Contact/Responsible Party
Tax Map 157, Lot 1	Iron Horse Properties, LLC 105 Bartlett Street Portsmouth, NH 03801
Private Roadway	Iron Horse Properties, LLC 105 Bartlett Street Portsmouth, NH 03801
Map 157, Lot 2	Portsmouth Lumber & Hardware, LLC 105 Bartlett Street Portsmouth, NH 03801
Map 164, Lot 1	Portsmouth Lumber & Hardware, LLC 105 Bartlett Street Portsmouth, NH 03801

(Note: The contact information for the Contact/Responsible Party shall be kept current. If ownership changes, the Operation and Maintenance Plan must be transferred to the new party.)

6.2 Maintenance Items

Maintenance of the following items shall be recorded:

- *Litter/Debris Removal*
- *Landscaping*
- *Catchbasin Cleaning*
- *Pavement Sweeping*
- *Contech Jellyfish Filtration System*
- *Porous Pavement*
- *Rain Garden*

The following maintenance items and schedule represent the minimum action required. Periodic site inspections shall be conducted, and all measures must be maintained in effective operating condition. The following items shall be observed during site inspection and maintenance:

- Inspect vegetated areas, particularly slopes and embankments for areas of erosion. Replant and restore as necessary
- Inspect catch basins for sediment buildup
- Inspect site for trash and debris

6.3 Overall Site Operation & Maintenance Schedule

Maintenance Item	Frequency of Maintenance	Location
Litter/Debris Removal	Weekly	Tax Map 157, Lot 1 Private Roadway Map 157, Lot 2 Map 164, Lot 1
Pavement Sweeping - Sweep impervious areas to remove sand and litter.	Annually	Tax Map 157, Lot 1 Private Roadway Map 157, Lot 2 Map 164, Lot 1
Landscaping - Landscaped islands to be maintained and mulched.	Maintained as required and mulched each Spring	Tax Map 157, Lot 1 Private Roadway Map 157, Lot 2 Map 164, Lot 1
Catch Basin (CB) Cleaning - CB to be cleaned of solids and oils.	Annually	Tax Map 157, Lot 1 Private Roadway Map 157, Lot 2 Map 164, Lot 1
Rain Garden - Trash and debris to be removed. - Any required maintenance shall be addressed.	Two (2) times annually and after any rainfall event exceeding 2.5" in a 24-hr period	Tax Map 157, Lot 1
Plunge Pools - Trash and debris to be removed. - Any required maintenance shall be addressed.	Annually	Tax Map 157, Lot 1 Private Roadway
Jelly Fish Units	In accordance with Manufacturer's Recommendations	Tax Map 157, Lot 1 Private Roadway
Underground Detention Basin - Visual observation of sediment levels within system	Annually	Tax Map 157, Lot 1
Porous Pavement - Clean using a vacuum sweeper	Bi-Annually	Tax Map 157, Lot 1

Rain Garden Inspection/Maintenance Requirements		
Inspection/ Maintenance	Frequency	Action
Monitor to ensure that Rain Gardens function effectively after storms	Two (2) times annually and after any rainfall event exceeding 2.5" in a 24-hr period	<ul style="list-style-type: none"> - Trash and debris to be removed - Any required maintenance shall be addressed
Inspect Vegetation	Annually	<ul style="list-style-type: none"> - Inspect the condition of all Rain Garden vegetation - Prune back overgrowth - Replace dead vegetation - Remove any invasive species
Inspect Drawdown Time - The system shall drawdown within 48-hours following a rainfall event.	Annually	<ul style="list-style-type: none"> - Assess the condition of the facility to determine measures required to restore the filtration function, including but not limited to removal of accumulated sediments or reconstruction of the filter.

Contech Jellyfish Filter System Inspection/Maintenance Requirements		
Inspection/ Maintenance	Frequency	Action
Inspect vault for sediment build up, static water, plugged media and bypass condition	One (1) time annually and after any rainfall event exceeding 2.5" in a 24-hr period	Maintenance required for any of the following: <ul style="list-style-type: none"> - >4" of sediment on the vault floor - >1/4" of sediment on top of the cartridge - .4" of static water above the cartridge bottom more than 24 hours after a rain event - If pore space between media is absent. - If vault is in bypass condition during an average rainfall event.
Replace Cartridges	As required by inspection, 1-5 years.	<ul style="list-style-type: none"> - Remove filter cartridges per manufacturer methods. - Vacuum sediment from vault. - Install new cartridges per manufacturer methods

Porous Asphalt Inspection/Maintenance Requirements		
Inspection/ Maintenance	Frequency	Action
Monitor for sediment build up, particularly in the winter.	Two (2) – Four (4) Times Annually.	- Clean with vacuum sweeper, bi-annually - Loose debris such as leaves or can be removed using a power/leaf blower or gutter broom. Fall and spring cleanup should be accompanied by pavement vacuuming.
Inspect Adjacent Vegetation	Two (2) – Four (4) Times Annually.	- Repair or replace any eroded areas.
Inspect for standing water -Within 30 minutes following a rain event.	One (1) – Two (2) Times Annually	- Use of a power washer or compressed air blower at an angle of 30 degrees or less can be effective, vacuum or vacuum sweeper if necessary.
Damage to pavement	As needed	- Repairs should be made as identified.

Additional Porous Asphalt Operation and Maintenance Requirements:

- ***No winter sanding or salting of porous pavements is permitted***
- Watering plants as necessary during the first growing season.
- Never reseal or repave with impermeable materials.
- Inspect annually for pavement deterioration or spalling.
- Monitor periodically to ensure the pavement surface drains effectively after storms.

6.3.1 Disposal Requirements

Disposal of debris, trash, sediment and other waste material should be done at suitable disposal/recycling sites and in compliance with all applicable local, state and federal waste regulations.

6.3.2 Snow & Ice Management for Standard Asphalt and Walkways

Snow storage areas shall be located such that no direct untreated discharges are possible to receiving waters from the storage site (snow storage areas have been shown on the Site Plan). The property manager will be responsible for timely snow removal from all private sidewalks, driveways, and parking areas. Snow removal will be hauled off-site and legally disposed of when snowbanks exceed 6 feet in height. Salt storage areas shall be covered or located such that no direct untreated discharges are possible to receiving waters from the storage site. Salt and sand shall be used to the minimum extent practical (refer to the attached for de-icing application rate guideline from the New Hampshire Stormwater Management Manual, Volume 2,).

6.4 Chloride Management Plan

Winter Operational Guidelines

The following Chloride Management Plan is for the 105 Bartlett Street, Multi-Family, Mixed Use Development in Portsmouth, New Hampshire. The Plan includes operational guidelines including winter operator certification requirements, weather monitoring, equipment calibration requirements, mechanical removal, and salt usage evaluation and monitoring. Due to the evolving nature of chloride management efforts, the Chlorides Management Plan will be reviewed annually, in advance of the winter season, to reflect the current management standards.

6.4.1 Background Information

The 105 Bartlett Street, Multi-Family Development is located along the North Mill Pond in Portsmouth, New Hampshire.

6.4.2 Operational Guidelines – Chloride Management

All private contractors engaged at the development site for the purposes of winter operational snow removal and surface maintenance, are responsible for assisting in meeting compliance for the following protocols. Private contractors are expected to minimize the effects of the use of de-icing, anti-icing and pretreatment materials by adhering to the strict guidelines outlined below.

The winter operational de-icing, anti-icing and pretreatment materials will adhere to the following protocols:

6.4.2.1 Winter Operator Certification Requirements

All private contractors engaged at the premises for the purpose of winter operational snow removal and surface maintenance must be current UNHT2 Green SnowPro Certified operators or equivalent and will use only pre-approved methods for spreading abrasives on private roadways and parking lots. All private contractors engaged at the premises for the purpose of winter operational snow removal and surface maintenance shall provide to the property management two copies of the annual UNHT2 Green SnowPro certificate or equivalent for each operator utilized on the premises. The annual UNHT2 Green SnowPro certificate or equivalent for each operator will be available on file in the Facilities Management office and be present in the vehicle/carrier at all times.

6.4.2.2 Improved Weather Monitoring

The property manager will coordinate weather information for use by winter maintenance contractors. This information in conjunction with site specific air/ground surface temperature monitoring will ensure that private contractors engaged at the premises for the purpose of winter operational snow removal and surface maintenance will make more informed decisions as to when and to what

extent de-icing, anti-icing and pretreatment materials are applied to private roadways, sidewalks, and parking lots.

6.4.2.3 Equipment Calibration Requirements

All equipment utilized on the premises for the purpose of winter operational snow removal and surface maintenance will conform to the following calibration requirements.

6.4.2.3.1 Annual Calibration Requirements

All private contractors engaged at the premises for the purpose of winter operational snow removal and surface maintenance shall provide two copies of the annual calibration report for each piece of equipment utilized on the premises. Each calibration report shall include the vehicle/carrier VIN number and the serial numbers for each component including, but not limited to, spreader control units, salt aggregate spreader equipment, brining/pre-wetting equipment, ground speed orientation unit, and air/ground surface temperature monitor. Annual calibration reports will be available on file in the Facilities Management office and be present in the vehicle/carrier at all times.

Prior to each use, each vehicle/carrier operator will perform a systems check to verify that unit settings remain within the guidelines established by the Management Team in order to accurately dispense material. All private contractors engaged at the premises for the purpose of winter operational snow removal and surface maintenance will be subject to spot inspections by members of the Property Management Team to ensure that each vehicle/carrier is operating in a manner consistent with the guidelines set herein or State and Municipal regulations. All units will be recalibrated, and the updated calibration reports will be provided each time repairs or maintenance procedures affect the hydraulic system of the vehicle/carrier.

6.4.2.4 Increased Mechanical Removal Capabilities

All private contractors engaged at the premises will endeavor to use mechanical removal means on a more frequent basis for roadways, parking lots and sidewalks. Dedicating more manpower and equipment to increase snow removal frequencies prevents the buildup of snow and the corresponding need for de-icing, anti-icing and pretreatment materials. Shortened maintenance routes, with shorter service intervals, will be used to stay ahead of snowfall. Minimized snow and ice packing will reduce the need for abrasives, salt aggregates, and/or brining solution to restore surfaces back to bare surface states after winter precipitation events.

After storm events the management team will be responsible for having the streets swept to recapture un-melted de-icing materials, when practical.

6.4.3 Salt Usage Evaluation and Monitoring

All private contractors engaged at the premises for the purpose of winter operational snow removal and surface maintenance shall provide two copies of a storm report, which includes detailed information regarding treatment areas and the use of de-icing, anti-icing and pretreatment materials applied for the removal of snow and surface maintenance on the premises. The property manager will maintain copies of Summary Documents, including copies of the Storm Reports, operator certifications, equipment used for roadway and sidewalk winter maintenance, calibration reports and amount of de-icing materials used.

6.4.4 Summary

The above-described methodologies are incorporated into the Operational Manual and are to be used to qualify and retain all private contractors engaged at the 105 Bartlett Street premises for the purpose of winter operational snow removal and surface maintenance. This section of the Manual is intended to be an adaptive management document that is modified as required based on experience gained from past practices and technological advancements that reflect chloride BMP standards. All employees directly involved with winter operational activities are required to review this document and the current standard Best Management Practices published by the UNH Technology Transfer (T2) program annually. All employees directly involved with winter operational activities, and all private contractors engaged at the premises for the purposes of winter operational snow removal and surface maintenance, must be current UNHT2 Green SnowPro Certified operators or equivalent and undergo the necessary requirements to maintain this certification annually.

Deicing Application Rate Guidelines

24' of pavement (typical two-lane road)

These rates are not fixed values, but rather the middle of a range to be selected and adjusted by an agency according to its local conditions and experience.

Pavement Temp. (°F) and Trend (↑↓)	Weather Condition	Maintenance Actions	Pounds per two-lane mile			
			Salt Prewetted / Pretreated with Salt Brine	Salt Prewetted / Pretreated with Other Blends	Dry Salt*	Winter Sand (abrasives)
> 30° ↑	Snow	Plow, treat intersections only	80	70	100*	Not recommended
	Freezing Rain	Apply Chemical	80 - 160	70 - 140	100 - 200*	Not recommended
30° ↓	Snow	Plow and apply chemical	80 - 160	70 - 140	100 - 200*	Not recommended
	Freezing Rain	Apply Chemical	150 - 200	130 - 180	180 - 240*	Not recommended
25° - 30° ↑	Snow	Plow and apply chemical	120 - 160	100 - 140	150 - 200*	Not recommended
	Freezing Rain	Apply Chemical	150 - 200	130 - 180	180 - 240*	Not recommended
25° - 30° ↓	Snow	Plow and apply chemical	120 - 160	100 - 140	150 - 200*	Not recommended
	Freezing Rain	Apply Chemical	160 - 240	140 - 210	200 - 300*	400
20° - 25° ↑	Snow or Freezing Rain	Plow and apply chemical	160 - 240	140 - 210	200 - 300*	400
20° - 25° ↓	Snow	Plow and apply chemical	200 - 280	175 - 250	250 - 350*	Not recommended
	Freezing Rain	Apply Chemical	240 - 320	210 - 280	300 - 400*	400
15° - 20° ↑	Snow	Plow and apply chemical	200 - 280	175 - 250	250 - 350*	Not recommended
	Freezing Rain	Apply Chemical	240 - 320	210 - 280	300 - 400*	400
15° - 20° ↓	Snow or Freezing Rain	Plow and apply chemical	240 - 320	210 - 280	300 - 400*	500 for freezing rain
0° - 15° ↑↓	Snow	Plow, treat with blends, sand hazardous areas	Not recommended	300 - 400	Not recommended	500 - 750 spot treatment as needed
< 0°	Snow	Plow, treat with blends, sand hazardous areas	Not recommended	400 - 600**	Not recommended	500 - 750 spot treatment as needed

* Dry salt is not recommended. It is likely to blow off the road before it melts ice.

** A blend of 6 - 8 gal/ton MgCl₂ or CaCl₂ added to NaCl can melt ice as low as -10°.

Anti-icing Route Data Form				
Truck Station:				
Date:				
Air Temperature	Pavement Temperature	Relative Humidity	Dew Point	Sky
Reason for applying:				
Route:				
Chemical:				
Application Time:				
Application Amount:				
Observation (first day):				
Observation (after event):				
Observation (before next application):				
Name:				

6.5 Invasive Species

With respect to a particular ecosystem, any species, including its seeds, eggs, spores, or other biological material capable of propagating that species, that is not native to that ecosystem is classified as an invasive species. Refer to the following fact sheet prepared by the University of New Hampshire Cooperative Extension entitled Methods for Disposing Non-Native Invasive Plants for recommended methods to dispose of invasive plant species.

6.6 Annual Updates and Log Requirements

The Owner and/or Contact/Responsible Party shall review this Operation and Maintenance Plan once per year for its effectiveness and adjust the plan and deed as necessary.

A log of all preventative and corrective measures for the stormwater system shall be kept on-site and be made available upon request by any public entity with administrative, health environmental or safety authority over the site including NHDES.

Copies of the Stormwater Maintenance report shall be submitted to the City of Portsmouth on an annual basis.

Stormwater Management Report						
Multi Family Development		105 Bartlett Street – Map 157, Lot 1 & Private Roadway				
BMP Description	Date of Inspection	Inspector	BMP Installed and Operating Properly?	Cleaning / Corrective Action Needed	Date of Cleaning / Repair	Performed By
Deep Sump CB's			<input type="checkbox"/> Yes <input type="checkbox"/> No			
Underground Detention			<input type="checkbox"/> Yes <input type="checkbox"/> No			
Jellyfish Filter 1			<input type="checkbox"/> Yes <input type="checkbox"/> No			
Jellyfish Filter 2			<input type="checkbox"/> Yes <input type="checkbox"/> No			
Jellyfish Filter 3			<input type="checkbox"/> Yes <input type="checkbox"/> No			
Jellyfish Filter 4			<input type="checkbox"/> Yes <input type="checkbox"/> No			
Porous Pavement			<input type="checkbox"/> Yes <input type="checkbox"/> No			
Rain Garden			<input type="checkbox"/> Yes <input type="checkbox"/> No			

Stormwater Management Report						
Ricci Lumber		105 Bartlett Street – Map 157, Lot 2 & Map 164, Lot 1				
BMP Description	Date of Inspection	Inspector	BMP Installed and Operating Properly?	Cleaning / Corrective Action Needed	Date of Cleaning / Repair	Performed By
Deep Sump CB's			<input type="checkbox"/> Yes <input type="checkbox"/> No			
			<input type="checkbox"/> Yes <input type="checkbox"/> No			
			<input type="checkbox"/> Yes <input type="checkbox"/> No			
			<input type="checkbox"/> Yes <input type="checkbox"/> No			

J:\C\C0960 Cathartes\C-0960-006 105 Bartlett Street\Report_Evaluation\Applications\City of Portsmouth\20210210 PB Submission\Drainage\C-0960-006_Drainage Report.docx







LEGEND

- EXISTING BUILDING
- EXISTING BUILDING TO BE RENOVATED OR REMOVED
- APPROXIMATE LOCATION OF HISTORIC ROUND HOUSE
- PROPOSED BUILDING
- ZONING LINE
- PROPERTY LINE

PROPOSED DEVELOPMENT
105 BARTLETT STREET
PORTSMOUTH, NH

CONSTRAINTS PLAN

BUILDING CONSTRAINTS	AREA
 PROPOSED DEVELOPMENT LOT	205,804 SF
 APPROXIMATE LOCATION OF CITY UTILITIES	15,547 SF
 NORTH MILL POND COMMUNITY SPACE AREA	47,703 SF
 VIEW CORRIDOR	14,413 SF
 15' MINIMUM RAILROAD SETBACK	8,727 SF

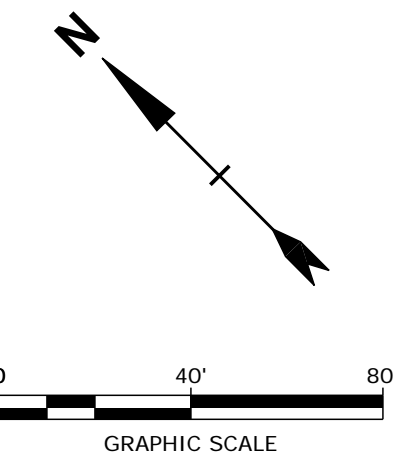

C-0960-006_C-CONSTRAINTS_CLR.dwg Date Plotted: Jan 19, 2021 - 10:46am Plotted By: NAHANSEN

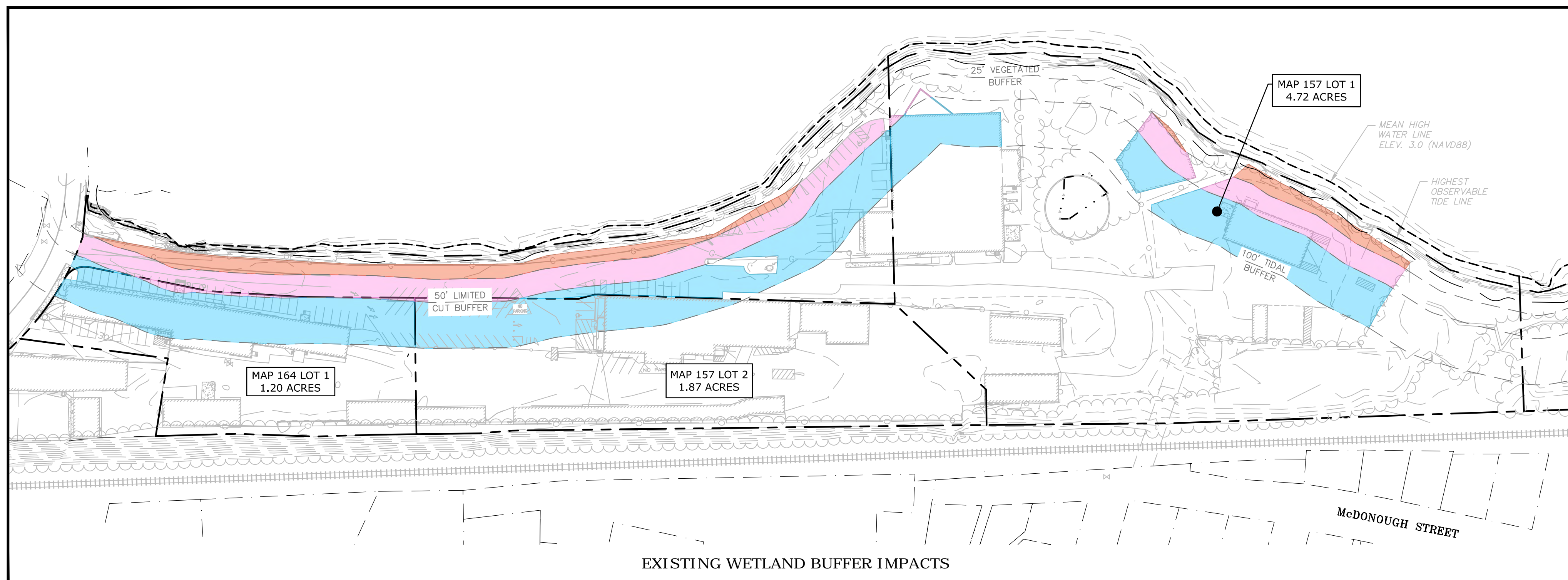
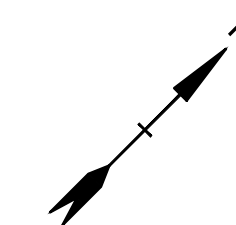

EXISTING WETLAND BUFFER IMPACTS

Wetland Buffer Setback	Buffer Impact Area for Project Parcels							
	Map 157 Lot 1		Roadway Lot		Map 157 Lot 2		Map 164 Lot 1	
	Existing Impact	Proposed Impact	Existing Impact	Proposed Impact	Existing Impact	Proposed Impact	Existing Impact	Proposed Impact
0 - 25 FT	3,094 SF (1)	0 SF	9,694 SF	6,788 SF	0 SF	0 SF	0 SF	0 SF
25 - 50 FT	7,537 SF (2)	3,138 SF	21,656 SF	17,998 SF	422 SF	422 SF	863 SF	836 SF
50 - 100 FT	20,407 SF (3)	11,949 SF	14,253 SF	11,849 SF	13,345 SF	12,610 SF	18,839 SF	16,135 SF
Total Lot Impact	31,038 SF	15,087 SF	45,603 SF	36,635 SF	13,767 SF	13,032 SF	19,702 SF	16,971 SF
Net Buffer Improvement on Parcels	15,951 SF		8,968 SF		735 SF		2,731 SF	
Overall Project Improvement	28,385 SF							

Notes:
 (1) Includes 147 SF of impact in 0 - 25 ft buffer from the existing railroad turntable structure.
 (2) Includes 1,806 SF of impact in 25 - 50 ft buffer from the existing railroad turntable structure.
 (3) Includes 2,397 SF of impact in 50 - 100 ft buffer from the existing railroad turntable structure.

Overall Buffer Impact Area		
Wetland Buffer Setback	Existing Impact	Proposed Impact
0 - 25 FT	12,788 SF	6,788 SF
25 - 50 FT	30,478 SF	22,394 SF
50 - 100 FT	66,844 SF	52,543 SF
Total Impact	110,110 SF	81,725 SF
NET BUFFER IMPROVEMENT		28,385 SF

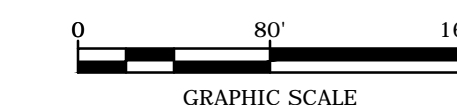

Proposed Multi-Family Development

Iron Horse Properties, LLC

105 Bartlett Street
 Portsmouth,
 New Hampshire

MARK	DATE	DESCRIPTION
I	3/10/2021	PB Submission
H	1/20/2021	TAC Resubmission
G	11/18/2020	TAC Resubmission
F	10/28/2020	Wetland CUP Resubmission
E	5/20/2020	TAC Resubmission
D	4/29/2020	Wetland CUP Submission
C	4/20/2020	TAC Submission
B	2/6/2020	Design Review Submission
A	1/2/2020	ZBA Submission

PROJECT NO:	C-0960-006
DATE:	April 20, 2020
FILE:	C-0960-006_C-SITE.DWG
DRAWN BY:	NAH
CHECKED:	PMC
APPROVED:	BML

OVERALL WETLAND BUFFER IMPACTS EXHIBIT

SCALE: AS SHOWN

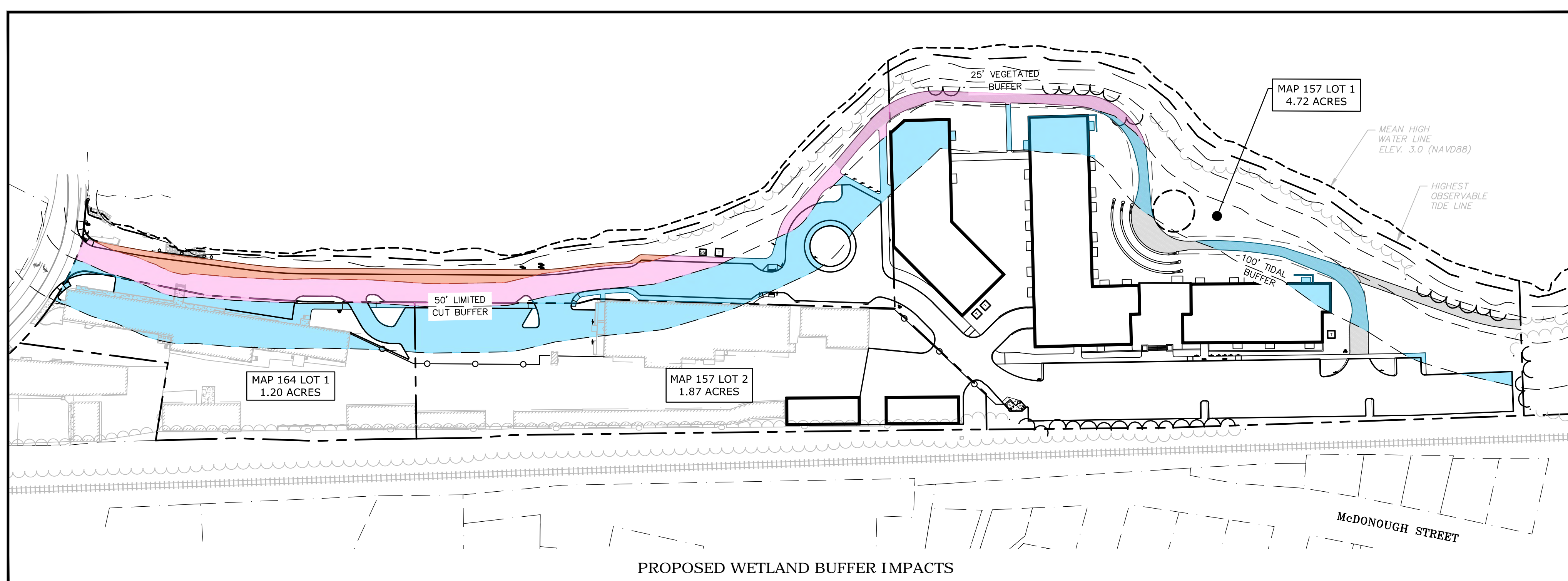

PROPOSED WETLAND BUFFER IMPACTS

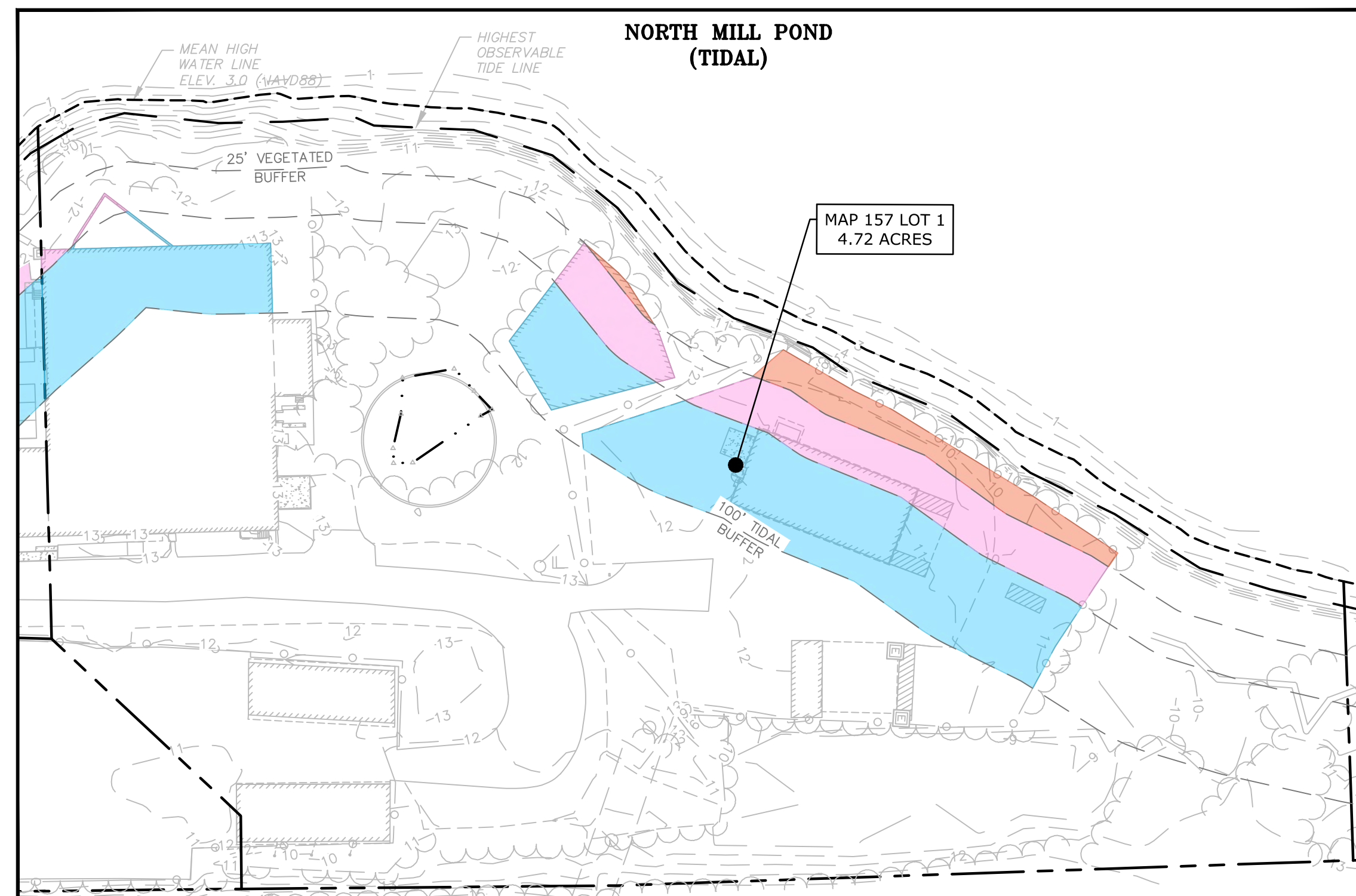

EXISTING WETLAND BUFFER IMPACTS
= 31,038 SF

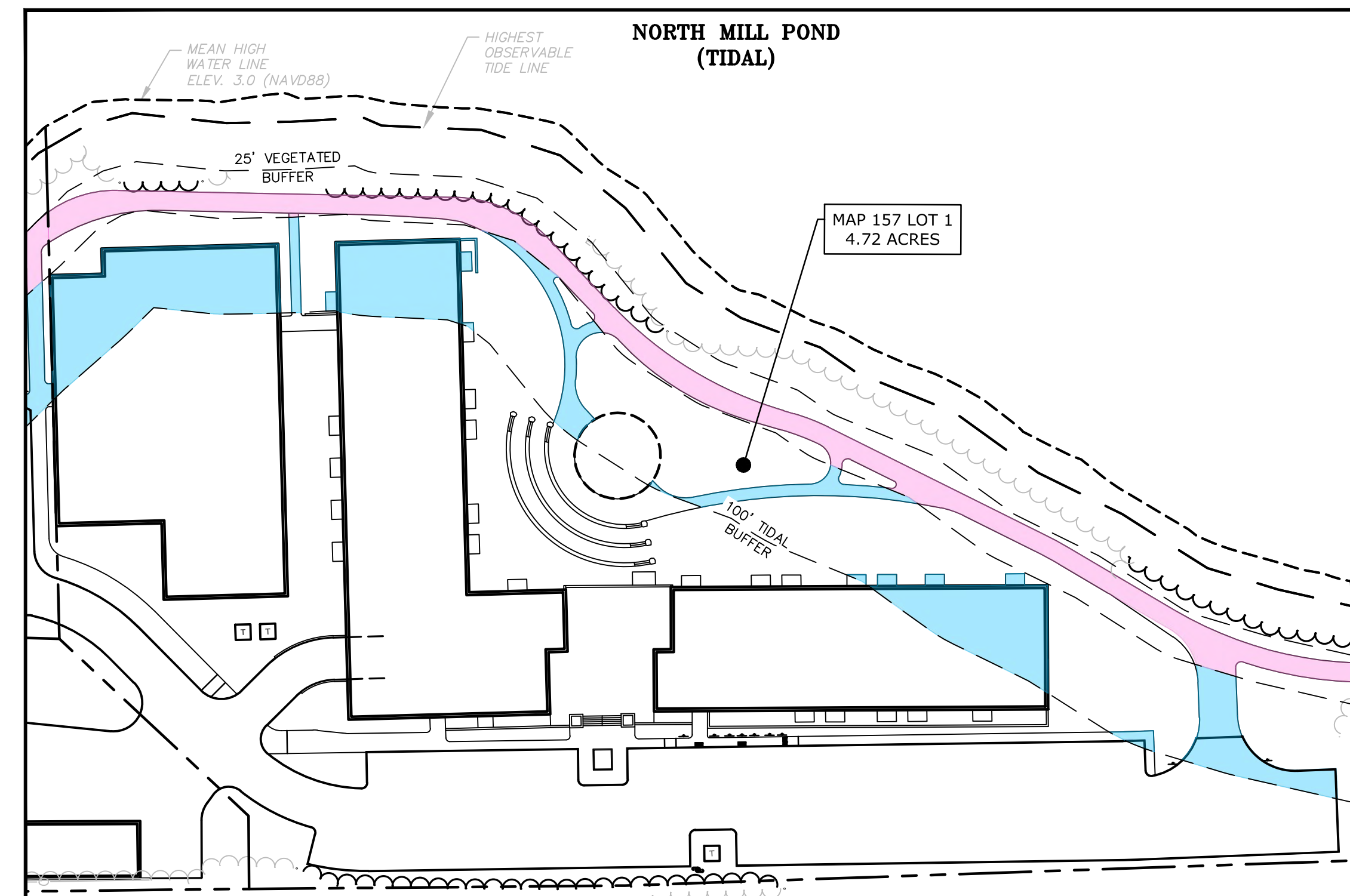

WETLAND BUFFER IMPACTS - NOVEMBER 18, 2020 TAC SUBMISSION
= 23,240 SF (7,798 SF IMPROVEMENT)

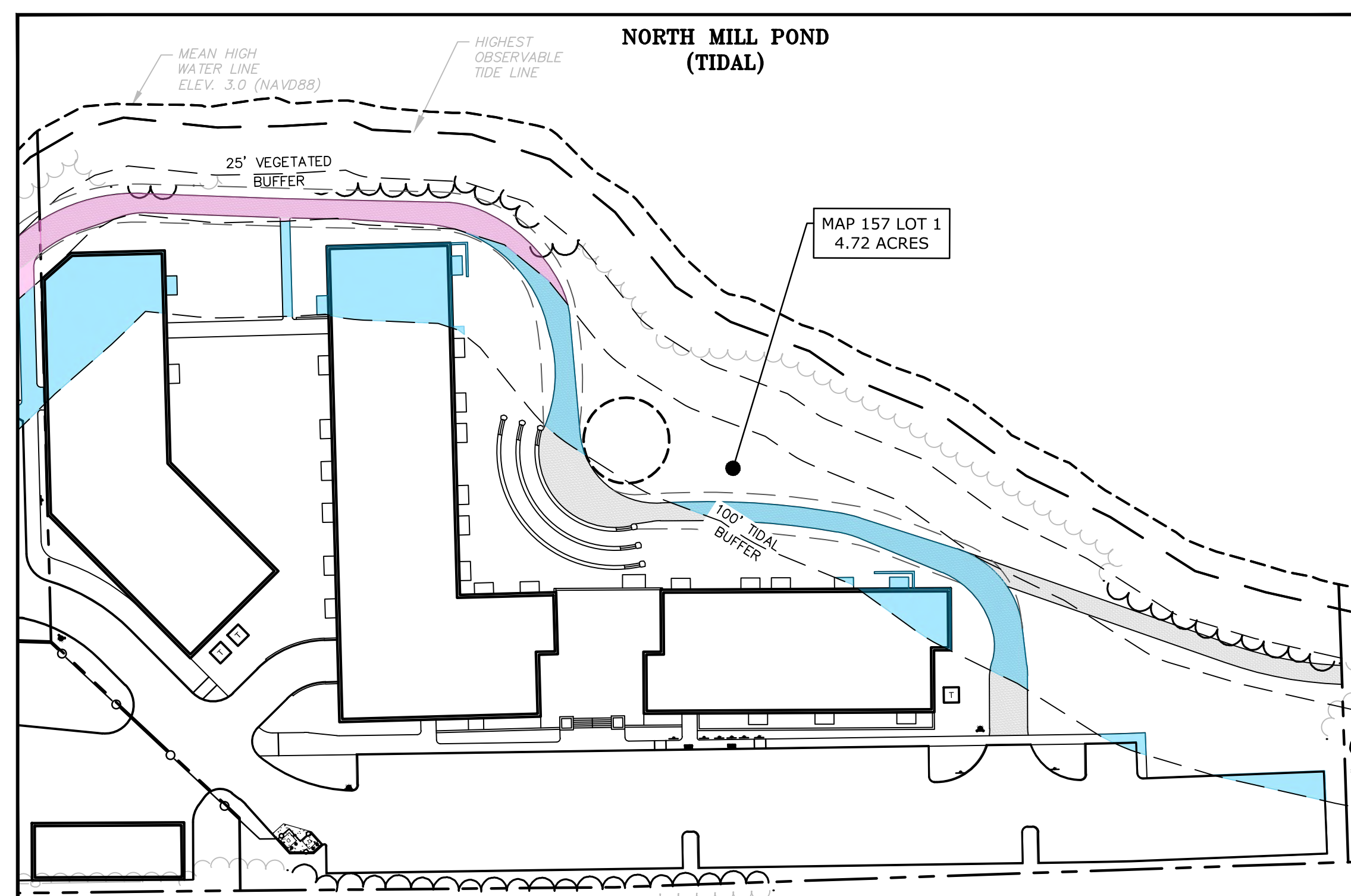
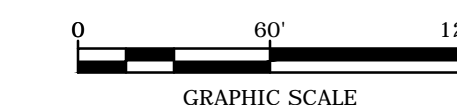

PROPOSED WETLAND BUFFER IMPACTS
= 17,005 SF (14,033 SF IMPROVEMENT)

Development Lot Buffer Impact Area			
Wetland Buffer Setback	Existing Impact	11/18/2020 TAC Submission Impact	Proposed Impact
0 - 25 FT	3,094 SF	0 SF	0 SF
25 - 50 FT	7,537 SF	8,542 SF	3,138 SF
50 - 100 FT	20,407 SF	14,698 SF	11,949 SF
Total Impact	31,038 SF	23,240 SF	15,087 SF
NET BUFFER IMPROVEMENT		7,798 SF	15,951 SF

Proposed Multi-Family Development

Iron Horse Properties, LLC

105 Bartlett Street
Portsmouth,
New Hampshire

MARK	DATE	DESCRIPTION
I	3/10/2021	PB Submission
H	1/20/2021	TAC Resubmission
G	11/18/2020	TAC Resubmission
F	10/28/2020	Wetland CUP Resubmission
E	5/20/2020	TAC Resubmission
D	4/29/2020	Wetland CUP Submission
C	4/20/2020	TAC Submission
B	2/6/2020	Design Review Submission
A	1/2/2020	ZBA Submission

PROJECT NO:	C-0960-006
DATE:	April 20, 2020
FILE:	C-0960-006_C-SITE.DWG
DRAWN BY:	NAH
CHECKED:	PMC
APPROVED:	BML

DEVELOPMENT LOT WETLAND BUFFER IMPACTS EXHIBIT

SCALE: AS SHOWN

PROPOSED MULTI-FAMILY DEVELOPMENT PORTSMOUTH, NEW HAMPSHIRE

PUBLIC OPEN SPACE EXHIBIT



PUBLIC OPEN SPACE:		PROVIDED	% OF LOT AREA
	GREENWAY COMMUNITY SPACE	47,703 SF	23.2%
	PUBLIC PARK	23,552 SF	11.4%
		71,255 SF 1.64 ACRES	34.6%

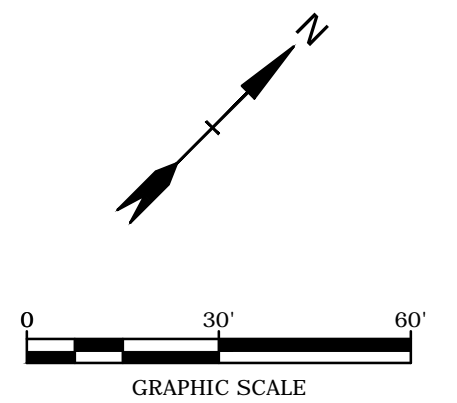



**TOTAL PROJECT IMPACT
WITHIN 100' BUFFER:
110,110 SF***

*EXCLUDES 9,698 SF OF EXISTING BUFFER IMPACT
AREA ON PORTION OF LOT 164 4-2 THAT IS NOT
PART OF THE CURRENT DEVELOPMENT AREA.

EXISTING CONDITION



**TOTAL PROJECT IMPACT
WITHIN 100' BUFFER:
113,545 SF**



AUGUST 2018 DEVELOPMENT LOT ACREAGE: 5.73

NUMBER OF UNITS: 120

PROPOSED REZONING



**TOTAL PROJECT IMPACT
WITHIN 100' BUFFER:
146,157 SF**



SEPTEMBER 2019 DEVELOPMENT LOT ACREAGE: 7.07

NUMBER OF UNITS: 272



**TOTAL PROJECT IMPACT
WITHIN 100' BUFFER:
97,739 SF**



MAY 2020 DEVELOPMENT LOT ACREAGE: 5.07

NUMBER OF UNITS: 174



**TOTAL PROJECT IMPACT
WITHIN 100' BUFFER:
89,170 SF**



OCTOBER 2020 DEVELOPMENT LOT ACREAGE: 4.71

NUMBER OF UNITS: 170





**TOTAL PROJECT IMPACT
WITHIN 100' BUFFER:
81,725 SF
(28,385 SF LESS THAN
EXISTING)**

JANUARY 2021 DEVELOPMENT LOT ACREAGE: 4.72

NUMBER OF UNITS: 152



BUILDING C GRADE PLANE ELEVATIONS													AVERAGE GRADE PLANE	13.28
POINT #	ELEV	POINT #	ELEV	POINT #	ELEV	POINT #	ELEV	POINT #	ELEV	POINT #	ELEV	POINT #		
1	12.70	18	13.10	35	14.30	52	14.30	69	11.45	86	13.10	103	14.35	
2	12.55	19	13.30	36	14.30	53	14.30	70	11.50	87	13.20	104	14.35	
3	12.40	20	13.50	37	14.30	54	14.30	71	11.55	88	13.30	105	14.30	
4	12.30	21	13.70	38	14.30	55	14.20	72	11.60	89	13.40	106	14.15	
5	12.20	22	13.95	39	14.30	56	14.05	73	11.75	90	13.50	107	14.00	
6	12.10	23	14.10	40	14.30	57	13.95	74	11.95	91	13.55	108	13.85	
7	12.05	24	14.30	41	14.30	58	13.50	75	12.05	92	13.65	109	13.75	
8	12.00	25	14.30	42	14.30	59	13.10	76	12.10	93	13.75	110	13.60	
9	12.00	26	14.30	43	14.30	60	13.00	77	12.20	94	13.80	111	13.45	
10	12.00	27	14.30	44	14.30	61	12.50	78	12.35	95	13.85	112	13.30	
11	12.00	28	14.30	45	14.30	62	12.10	79	12.50	96	13.95	113	13.15	
12	12.00	29	14.30	46	14.30	63	12.00	80	12.60	97	13.95	114	13.00	
13	12.00	30	14.30	47	14.30	64	11.80	81	12.70	98	14.00	115	12.95	
14	12.00	31	14.30	48	14.30	65	11.70	82	12.85	99	14.10	116	12.90	
15	12.00	32	14.30	49	14.30	66	11.60	83	12.95	100	14.15	117	12.80	
16	12.10	33	14.30	50	14.30	67	11.60	84	13.00	101	14.20	118	12.75	
17	12.70	34	14.30	51	14.30	68	11.50	85	13.05	102	14.30	119	12.73	

BUILDING A & B GRADE PLANE ELEVATIONS																								AVERAGE GRADE PLANE	16.39		
POINT #	ELEV	POINT #	ELEV	POINT #	ELEV	POINT #	ELEV	POINT #	ELEV	POINT #	ELEV	POINT #	ELEV	POINT #	ELEV	POINT #	ELEV	POINT #	ELEV	POINT #	ELEV	POINT #	ELEV				
200	17.50	217	17.50	234	17.50	251	12.60	268	16.20	285	16.40	302	17.50	319	16.90	336	17.50	353	17.50	370	16.15	387	17.50	404	17.50	421	14.00
201	17.50	218	17.50	235	17.50	252	12.95	269	16.60	286	16.00	303	17.50	320	16.90	337	17.50	354	17.50	371	16.20	388	17.50	405	17.50	422	14.20
202	17.50	219	17.50	236	17.50	253	13.10	270	17.00	287	15.80	304	17.50	321	16.70	338	17.50	355	17.50	372	16.35	389	17.50	406	17.50	423	14.50
203	17.50	220	17.50	237	17.50	254	13.25	271	17.40	288	15.80	305	17.50	322	16.50	339	17.50	356	17.50	373	17.00	390	17.50	407	17.50	424	14.75
204	17.50	221	17.50	238	17.50	255	13.40	272	17.50	289	17.50	306	17.50	323	16.20	340	17.50	357	17.50	374	17.50	391	17.50	408	17.50	425	14.90
205	17.50	222	17.50	239	17.50	256	13.60	273	17.50	290	17.50	307	17.50	324	16.05	341	17.50	358	17.50	375	17.50	392	17.50	409	17.50	426	15.00
206	17.50	223	17.50	240	17.50	257	13.75	274	17.50	291	17.50	308	17.50	325	16.00	342	17.50	359	17.50	376	17.50	393	17.50	410	17.50	427	15.10
207	14.50	224	17.50	241	7.90	258	13.85	275	17.50	292	17.50	309	17.50	326	15.00	343	17.50	360	17.50	377	17.50	394	17.50	411	17.50	428	15.20
208	14.50	225	17.50	242	7.90	259	13.95	276	15.50	293	17.50	310	17.50	327	14.50	344	17.50	361	17.00	378	17.50	395	17.50	412	17.50	429	15.15
209	15.00	226	17.50	243	7.95	260	14.00	277	15.50	294	17.50	311	17.50	328	13.80	345	17.50	362	16.80	379	17.50	396	17.50	413	17.50	430	15.10
210	17.00	227	17.50	244	7.95	261	14.10	278	15.50	295	17.50	312	17.50	329	13.70	346	17.50	363	16.10	380	17.50	397	17.50	414	17.50	431	15.00
211	17.50	228	17.50	245	12.70	262	14.40	279	15.50	296	17.50	313	17.50	330	13.60	347	17.50	364	16.05	381	17.50	398	17.50	415	17.50	432	15.00
212	17.50	229	17.50	246	12.65	263	14.90	280	17.50	297	17.50	314	16.20	331	13.55	348	17.50	365	16.10	382	17.50	399	17.50	416	17.50	433	15.00
213	17.50	230	17.50	247	12.60	264	15.20	281	17.50	298	17.50	315	16.25	332	13.50	349	17.50	366	16.10	383	17.50	400	17.50	417	17.50	434	15.90
214	17.50	231	17.50	248	12.55	265	15.30	282	17.50	299	17.50	316	16.85	333	13.60	350	17.50	367	16.10	384	17.50	401	17.50	418	15.00		
215	17.50	232	17.50	249	12.50	266	15.40	283	17.20	300	17.50	317	16.90	334	13.70	351	17.50	368	16.10	385	17.50	402	17.50	419	13.90	435	15.00
216	17.50	233	17.50	250	12.55	267	15.80	284	16.80	301	17.50	318	16.90	335	13.90	352	17.50	369	16.15	386	17.50	403	17.50	420	14.00		

	GRADE PLANE ELEVATION	BUILDING ELEVATION		BUILDING HEIGHT	
		ALLOWED	PROPOSED	ALLOWED	PROPOSED
BUILDING A	16.39'	66.39'	65.50'	50.00'	49.11'
BUILDING B	16.39'	66.39'	65.50'	50.00'	49.11'
BUILDING C	13.28'	63.28'	62.50'	50.00'	49.22'

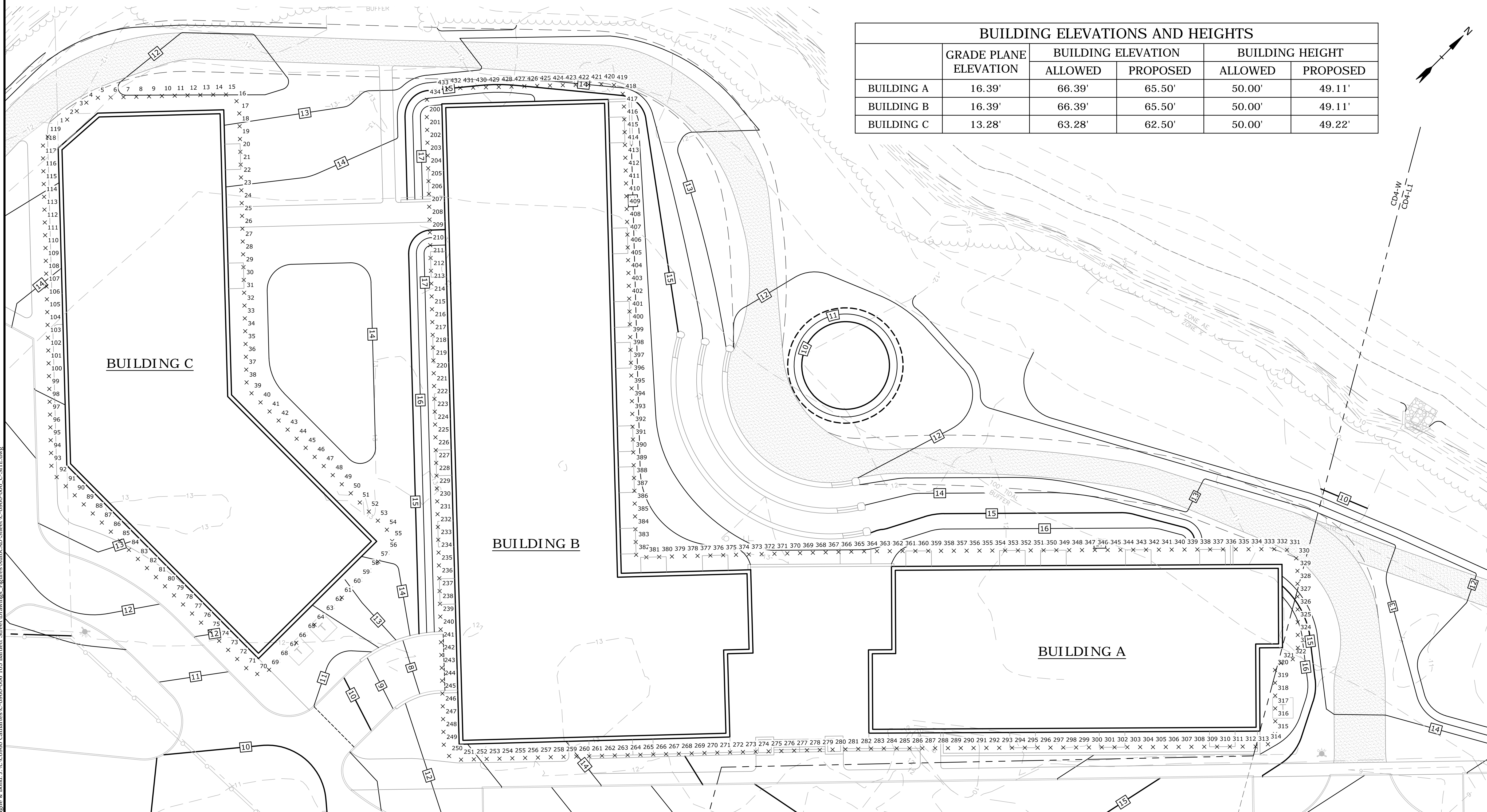

Proposed Multi-Family Development

Iron Horse Properties, LLC

**105 Bartlett Street
Portsmouth,
New Hampshire**

MARK	DATE	DESCRIPTION
I	3/10/2021	PB Submission
H	1/20/2021	TAC Resubmission
G	11/18/2020	TAC Resubmission
F	10/28/2020	Wetland CUP Resubmission
E	5/20/2020	TAC Resubmission
D	4/29/2020	Wetland CUP Submission
C	4/20/2020	TAC Submission
B	2/6/2020	Design Review Submission
A	1/2/2020	ZBA Submission

PROJECT NO: C-0960-006
 DATE: April 20, 2020
 FILE: C-0960-006_C-SITE.DWG
 DRAWN BY: NAH
 CHECKED: PMC
 APPROVED: BML

GRADE PLANE EXHIBIT
 SCALE: AS SHOWN

Last Saved: 3/9/2021
 Plotted On: Mar 09, 2021 1:48:58pm By: NAhansen
 Tighe & Bond, F.C. Collins, C-0960-006 105 Bartlett Street Drawings, Figures AutoCAD Sheet C-0960-006 C-SITE.dwg

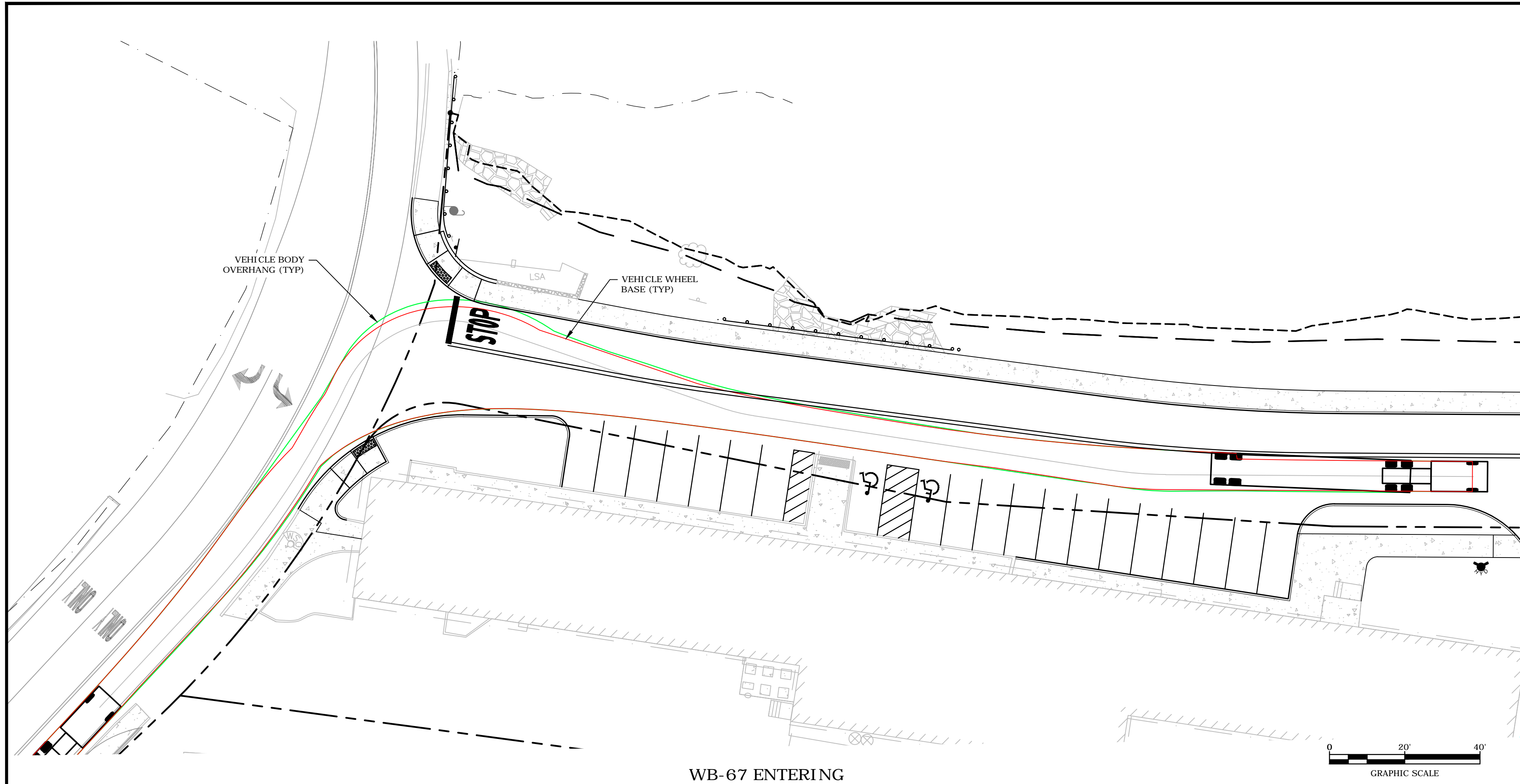
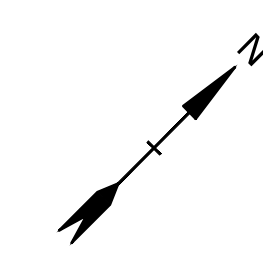

WB-67 ENTERING

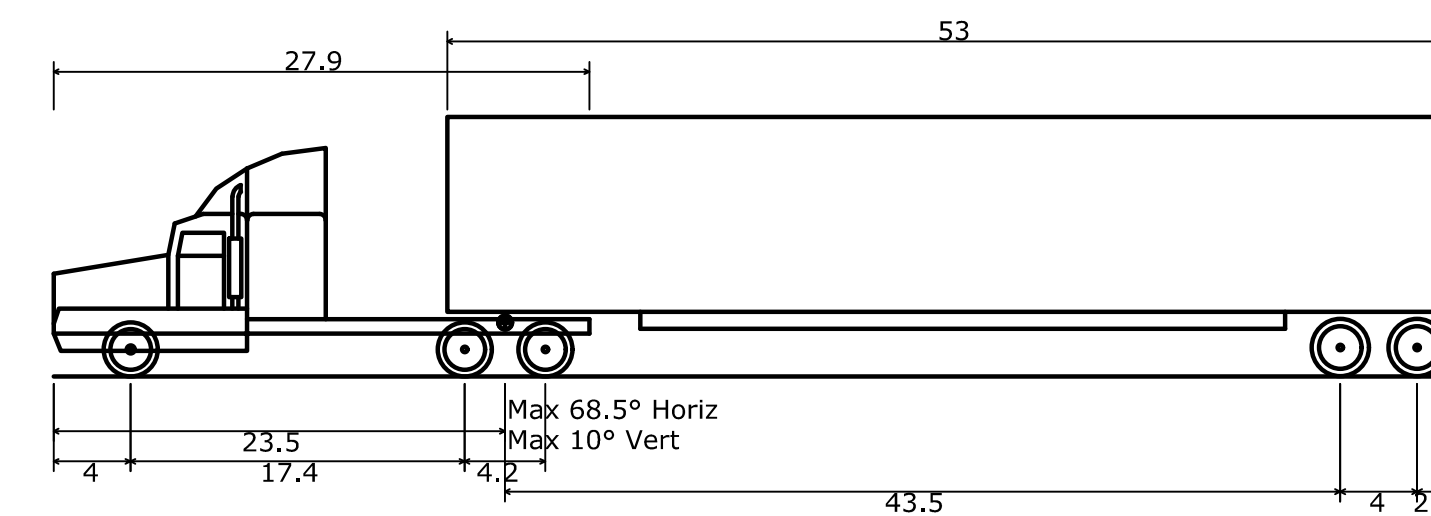

WB-67 - Interstate Semi-Trailer
 Overall Length 73.501ft
 Overall Width 8.500ft
 Overall Body Height 13.500ft
 Min Body Ground Clearance 1.334ft
 Max Track Width 8.500ft
 Lock-to-lock time 6.00s
 Max Steering Angle (Virtual) 28.40°

LEGEND
 ——— VEHICLE OVERHANG
 ——— VEHICLE WHEEL BASE

Proposed Multi-Family Development

Iron Horse Properties, LLC

105 Bartlett Street
 Portsmouth,
 New Hampshire

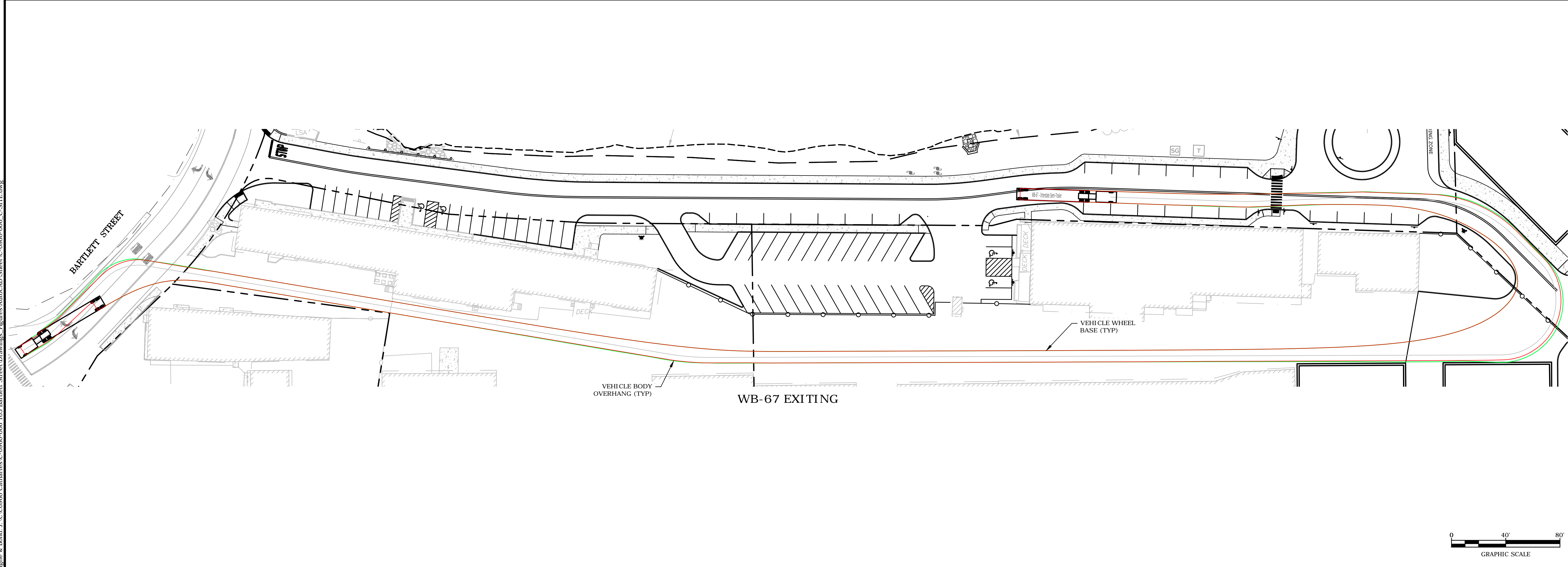

WB-67 EXITING

MARK	DATE	DESCRIPTION
I	3/10/2021	PB Submission
H	1/20/2021	TAC Resubmission
G	11/18/2020	TAC Resubmission
F	10/28/2020	Wetland CUP Resubmission
E	5/20/2020	TAC Resubmission
D	4/29/2020	Wetland CUP Submission
C	4/20/2020	TAC Submission
B	2/6/2020	Design Review Submission
A	1/2/2020	ZBA Submission

PROJECT NO:	C-0960-006
DATE:	April 20, 2020
FILE:	C-0960-006_C-SITE.DWG
DRAWN BY:	NAH
CHECKED:	PMC
APPROVED:	BML

TRUCK TURNING EXHIBIT

SCALE: AS SHOWN

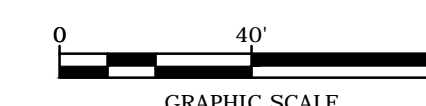

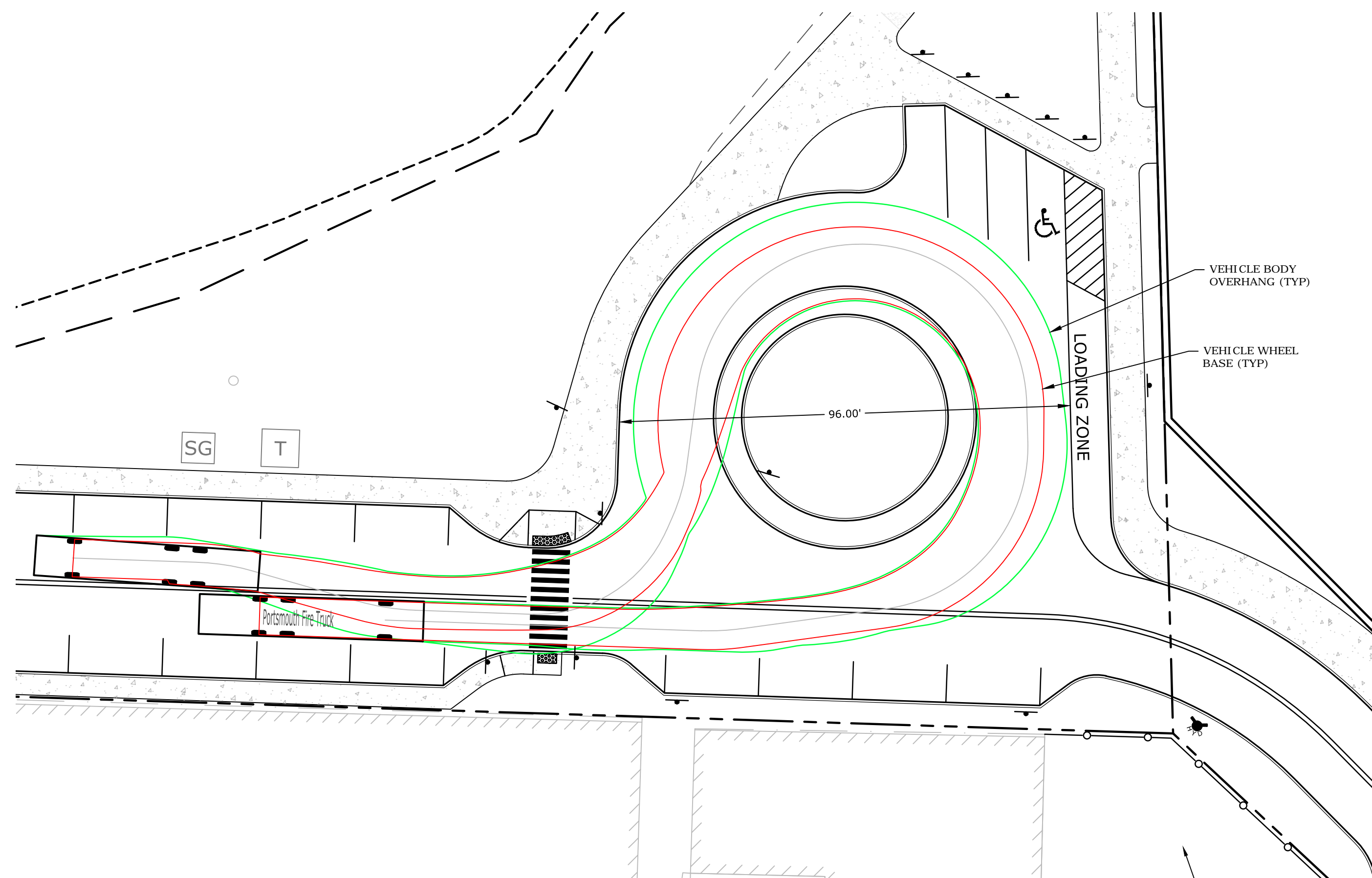

FIRE TRUCK CUL-DE-SAC

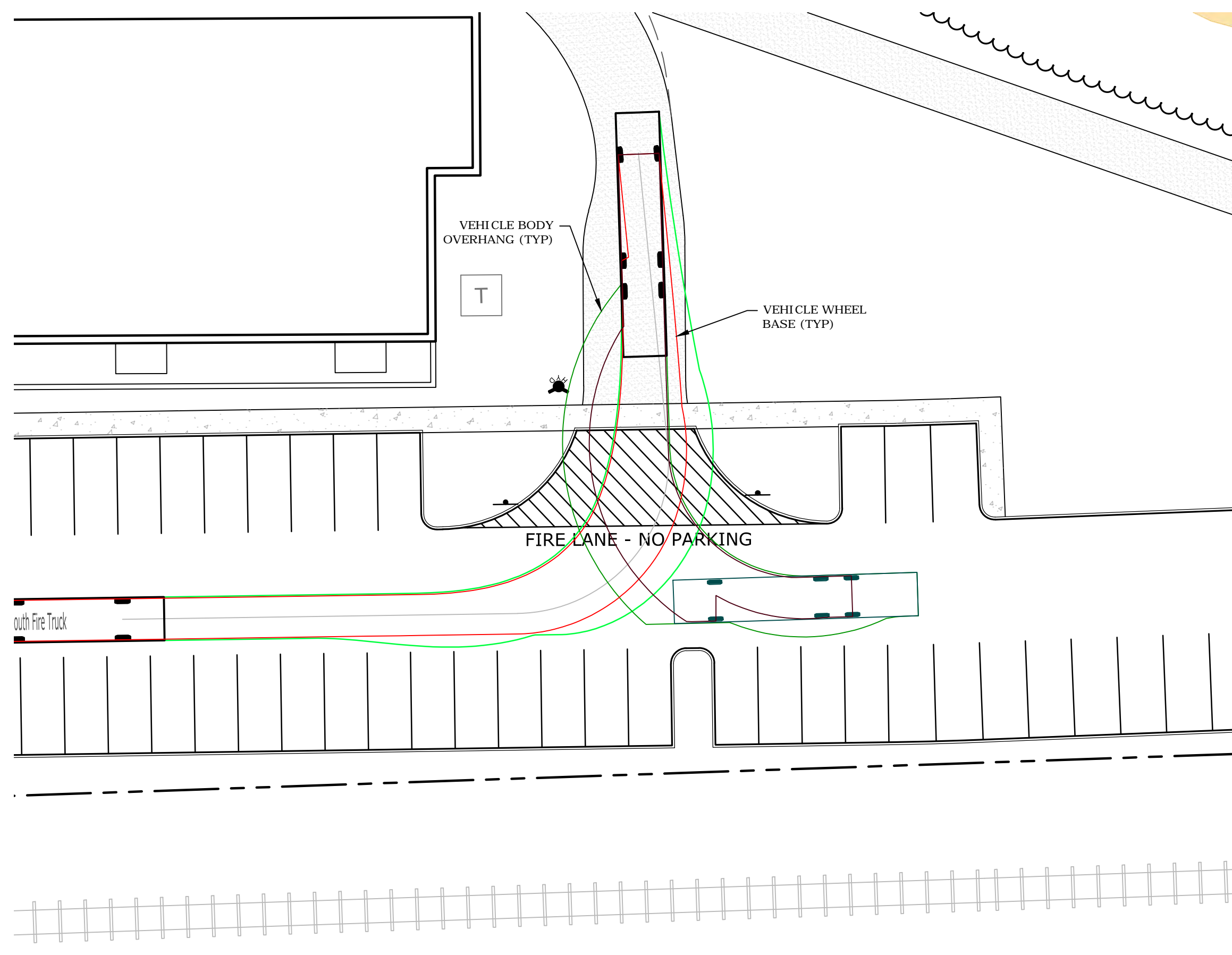

FIRE TRUCK TURN AROUND

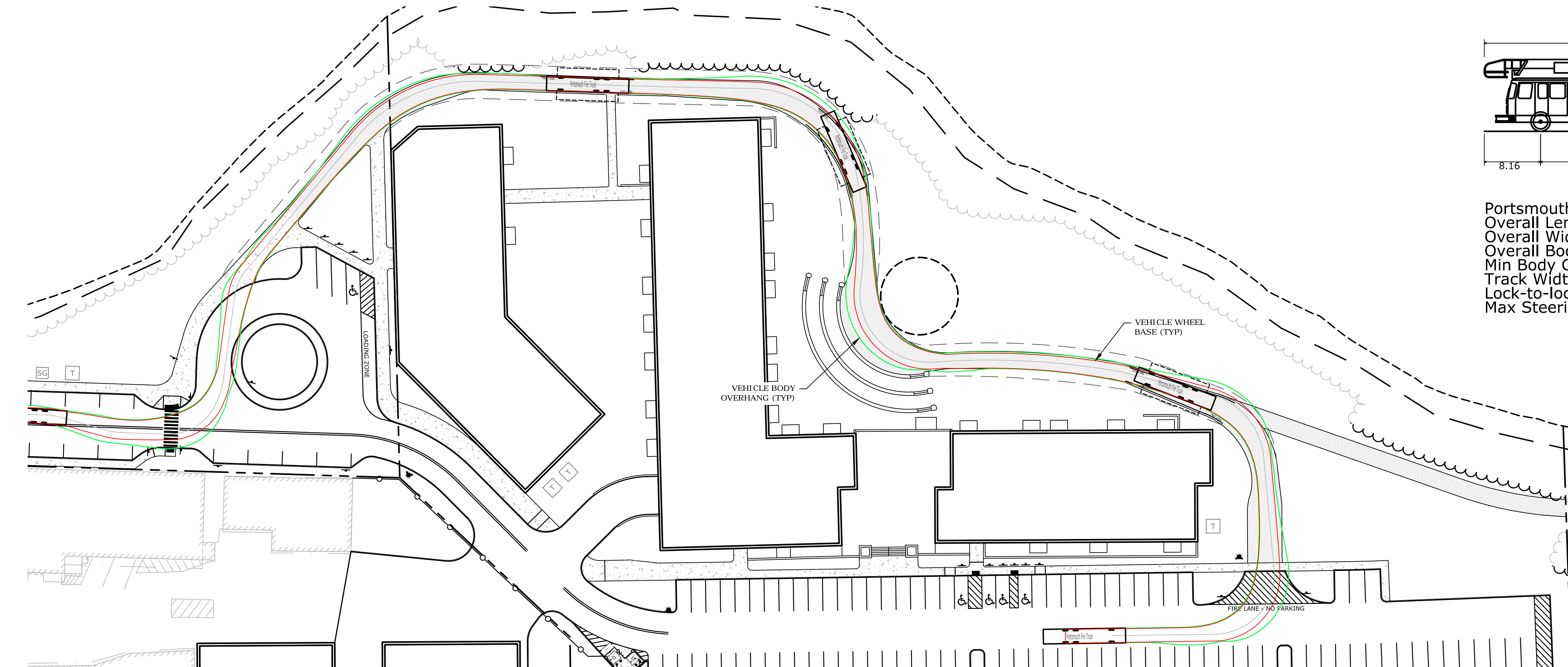
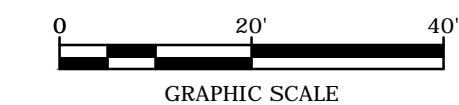

FIRE TRUCK - REAR BUILDING ACCESS

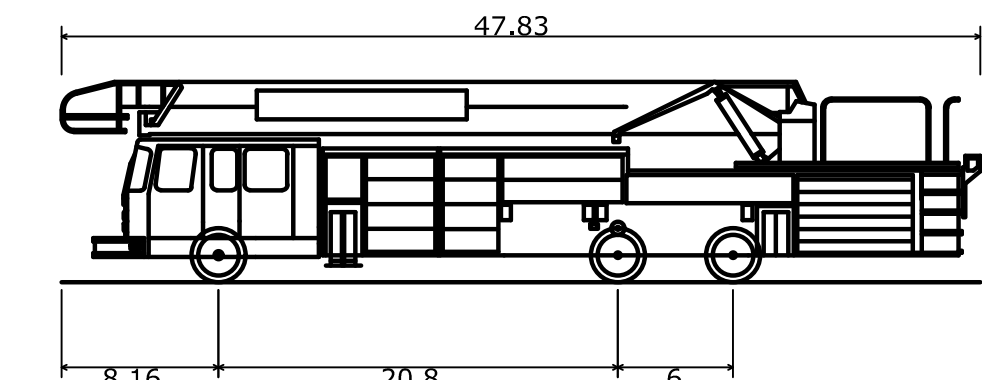

Portsmouth Fire Truck
 Overall Length 47.830ft
 Overall Width 8.500ft
 Overall Body Height 10.432ft
 Min Body Ground Clearance 0.862ft
 Track Width 8.000ft
 Lock-to-lock time 6.00s
 Max Steering Angle (Virtual) 38.00°

LEGEND

— VEHICLE OVERHANG

— VEHICLE WHEEL BASE

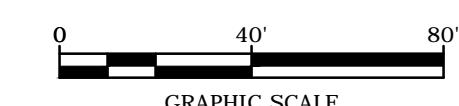

Proposed Multi-Family Development

Iron Horse Properties, LLC

105 Bartlett Street
 Portsmouth,
 New Hampshire

MARK	DATE	DESCRIPTION
I	3/10/2021	PB Submission
H	1/20/2021	TAC Resubmission
G	11/18/2020	TAC Resubmission
F	10/28/2020	Wetland CUP Resubmission
E	5/20/2020	TAC Resubmission
D	4/29/2020	Wetland CUP Submission
C	4/20/2020	TAC Submission
B	2/6/2020	Design Review Submission
A	1/2/2020	ZBA Submission

PROJECT NO:	C-0960-006
DATE:	April 20, 2020
FILE:	C-0960-006_C-SITE.DWG
DRAWN BY:	NAH
CHECKED:	PMC
APPROVED:	BML

TRUCK TURNING EXHIBIT

SCALE: AS SHOWN

Last Saved: 3/9/2021 1:58:48pm By: N.Hansman
 Plotted On: Mar 09, 2021 10:55:00am By: N.Hansman
 Tighe & Bond, P.C. 105 Bartlett Street, Portsmouth, NH 03801
 Figures Auto-CAD Sheet: C-0960-006_C-SITE.dwg

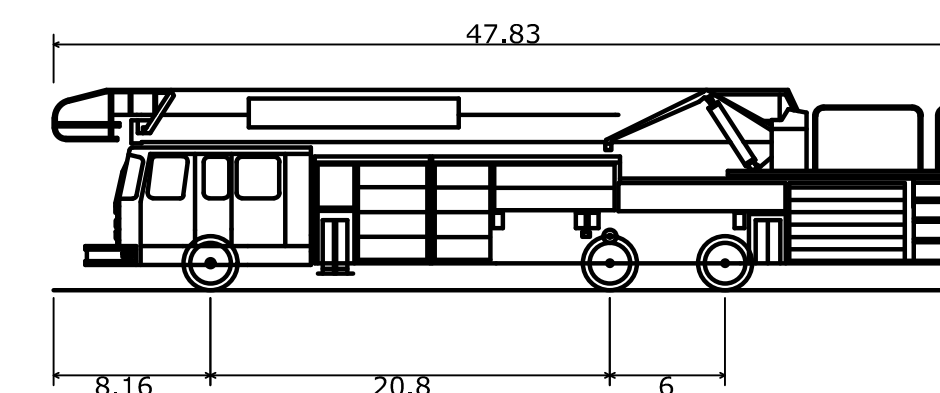
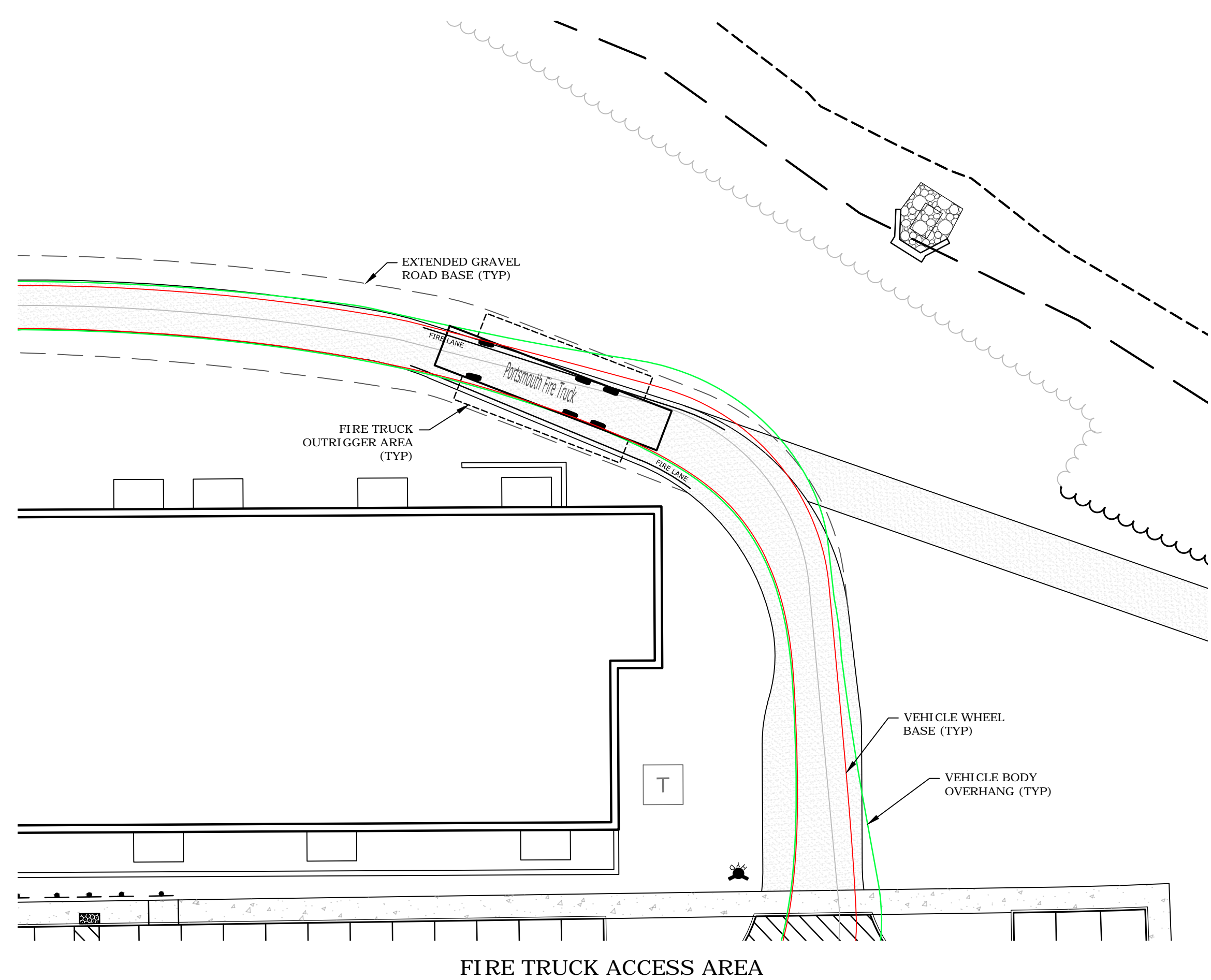
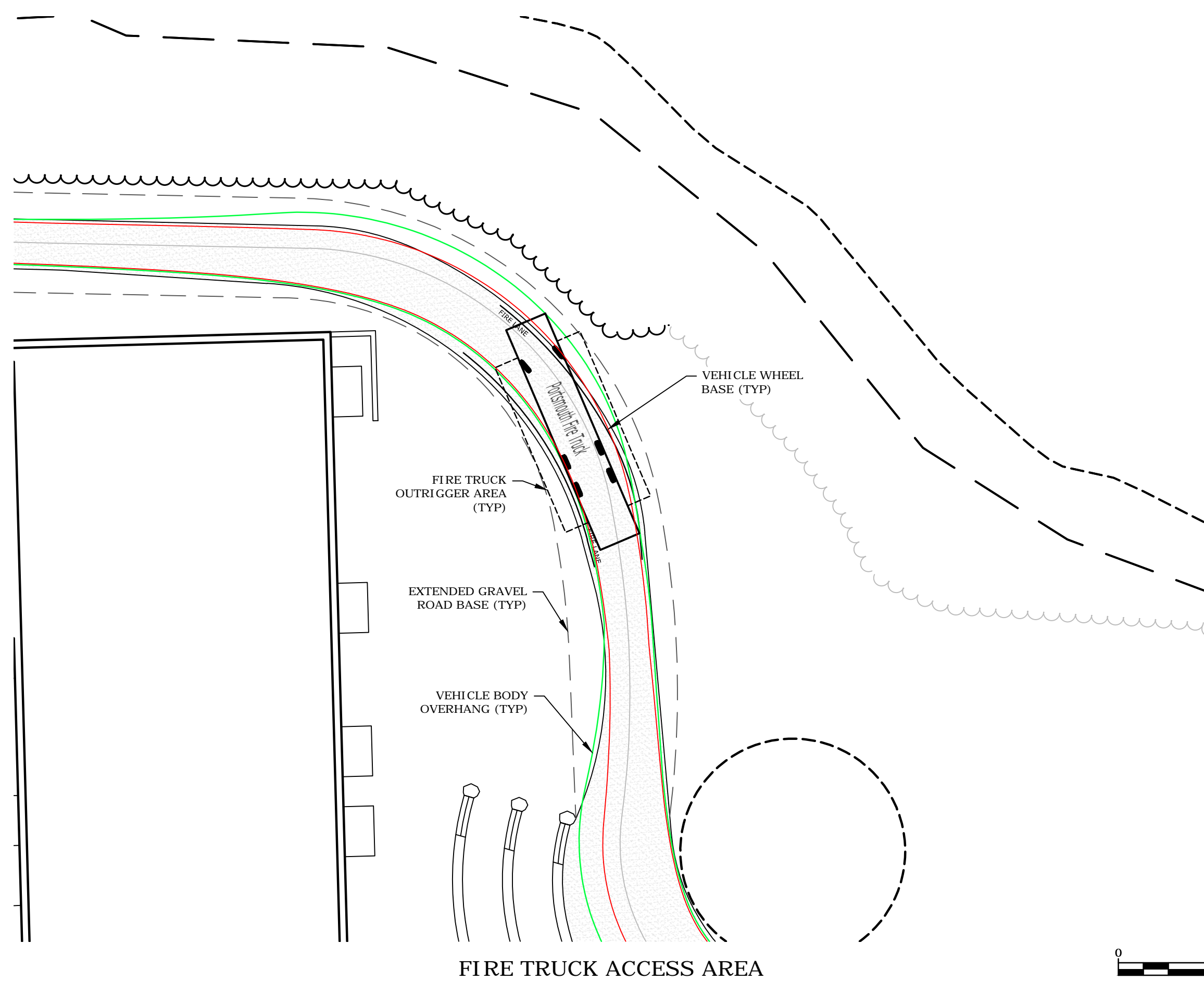
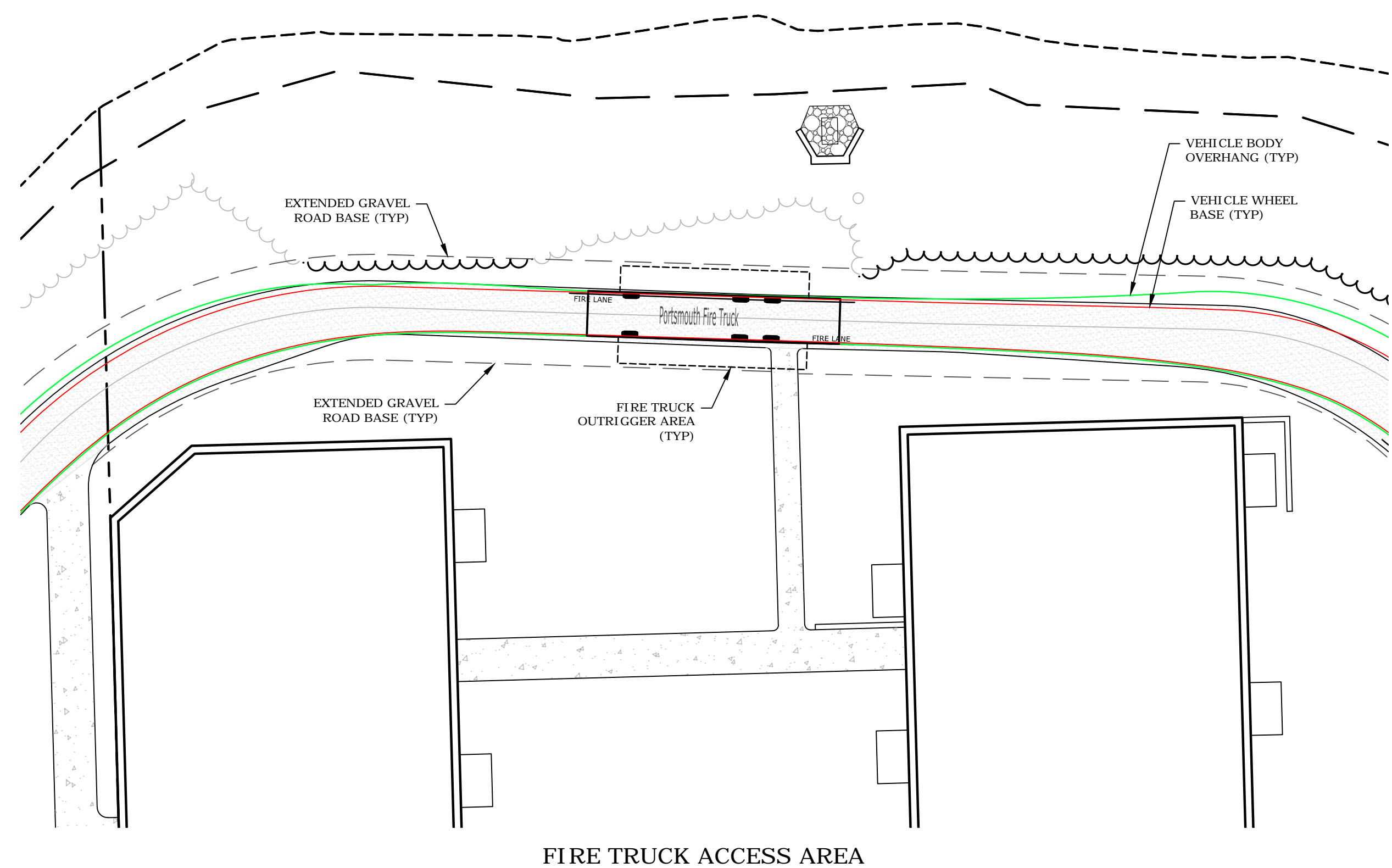

Portsmouth Fire Truck
 Overall Length 47.830ft
 Overall Width 8.500ft
 Overall Body Height 10.432ft
 Min Body Ground Clearance 0.862ft
 Track Width 8.000ft
 Lock-to-lock time 6.00s
 Max Steering Angle (Virtual) 38.00°

LEGEND

- VEHICLE OVERHANG
- VEHICLE WHEEL BASE

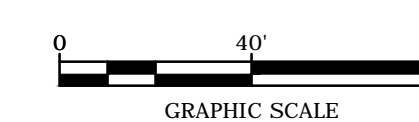

Proposed Multi-Family Development

Iron Horse Properties, LLC

105 Bartlett Street
 Portsmouth,
 New Hampshire

MARK	DATE	DESCRIPTION
I	3/10/2021	PB Submission
H	1/20/2021	TAC Resubmission
G	11/18/2020	TAC Resubmission
F	10/28/2020	Wetland CUP Resubmission
E	5/20/2020	TAC Resubmission
D	4/29/2020	Wetland CUP Submission
C	4/20/2020	TAC Submission
B	2/6/2020	Design Review Submission
A	1/2/2020	ZBA Submission

PROJECT NO:	C-0960-006
DATE:	April 20, 2020
FILE:	C-0960-006_C-SITE.DWG
DRAWN BY:	NAH
CHECKED:	PMC
APPROVED:	BML

TRUCK TURNING EXHIBIT

SCALE: AS SHOWN

IRON HORSE PROPERTIES, LLC
 PORTSMOUTH, NH
 PROPOSED LOT LINE REVISION PLAN

LEGEND

- EXISTING PROPERTY LINE
- EXISTING PROPERTY LINE TO BE ABANDONED
- PROPOSED PROPERTY LINE

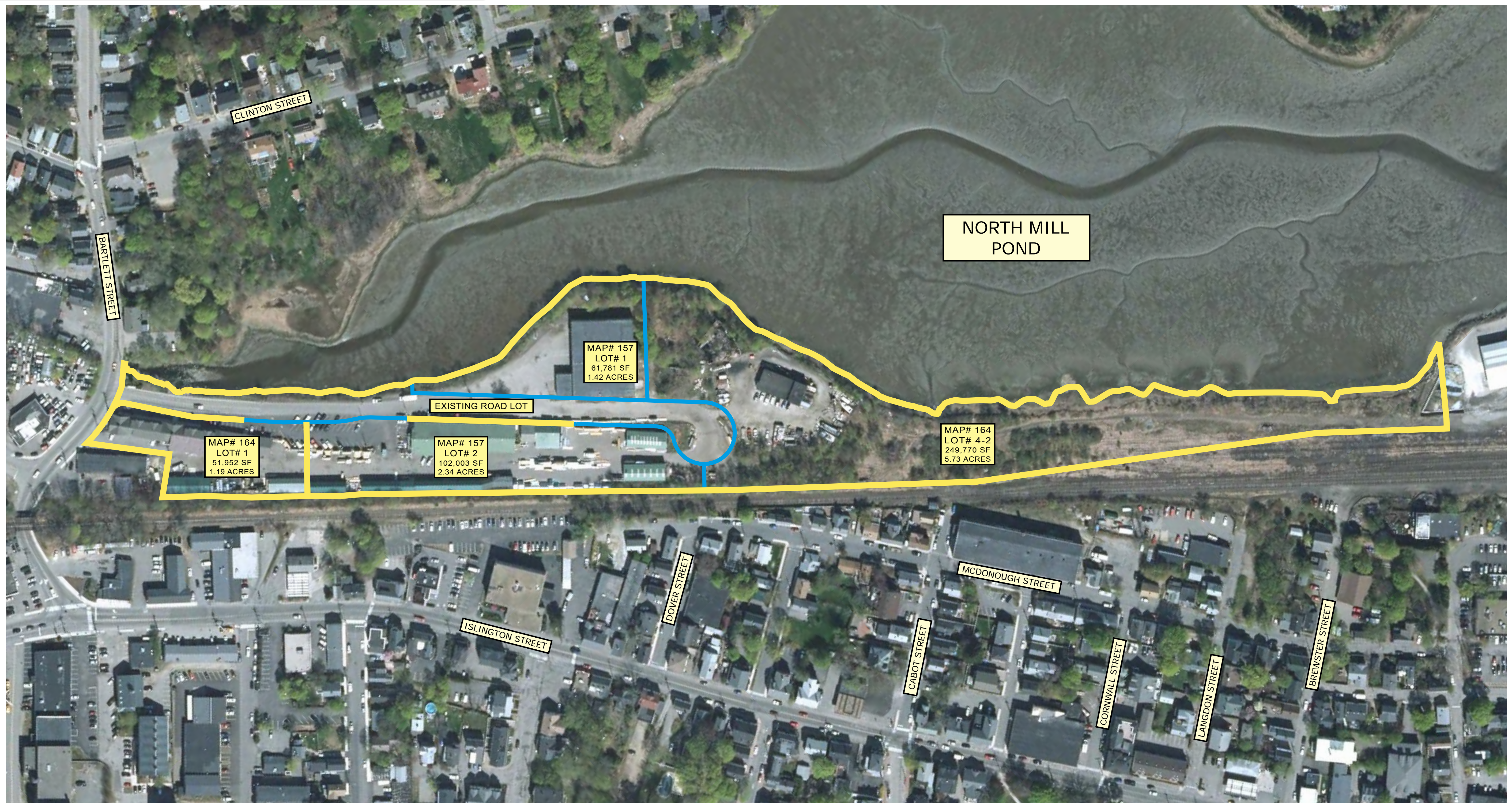
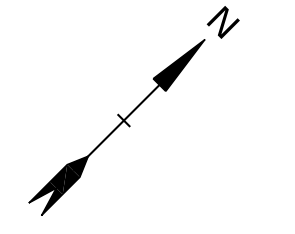

C:\0961\006_C-BOUNDARY.DWG Date Plotted: Jan 15, 2021 - 2:35pm Plotted By: NAHANSEN

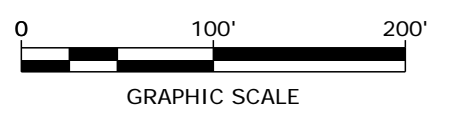

Tighe & Bond
 Engineers | Environmental Specialists
 177 Corporate Drive
 Portsmouth, New Hampshire 03801
 (603) 433-8818
 April 20, 2020

IRON HORSE PROPERTIES, LLC
 PORTSMOUTH, NH
 PROPOSED LOT LINE REVISION PLAN

LEGEND

- EXISTING PROPERTY LINE
- EXISTING PROPERTY LINE TO BE ABANDONED
- PROPOSED PROPERTY LINE

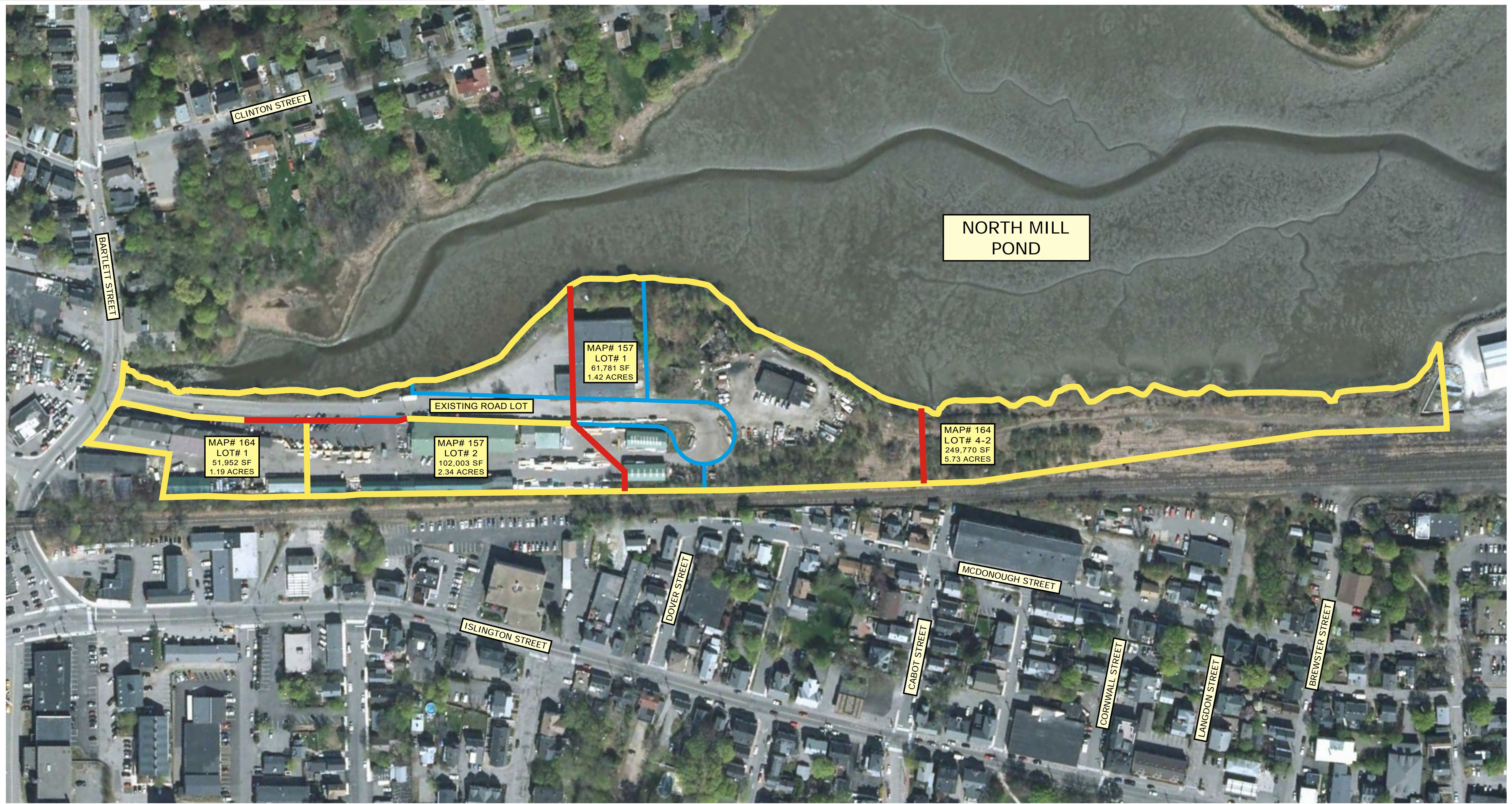
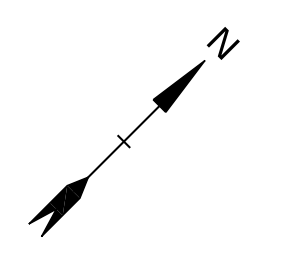

C:\0961\006_C-BOUNDARY.DWG Date Plotted: Jan 19, 2021 - 10:40am Plotted By: MAHANSEN

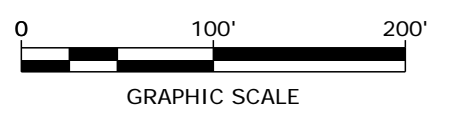

Tighe & Bond
 Engineers | Environmental Specialists
 177 Corporate Drive
 Portsmouth, New Hampshire 03801
 (603) 433-8818
 January 20, 2021

IRON HORSE PROPERTIES, LLC
 PORTSMOUTH, NH
PROPOSED LOT LINE REVISION PLAN

LEGEND

- EXISTING PROPERTY LINE
- EXISTING PROPERTY LINE TO BE ABANDONED
- PROPOSED PROPERTY LINE

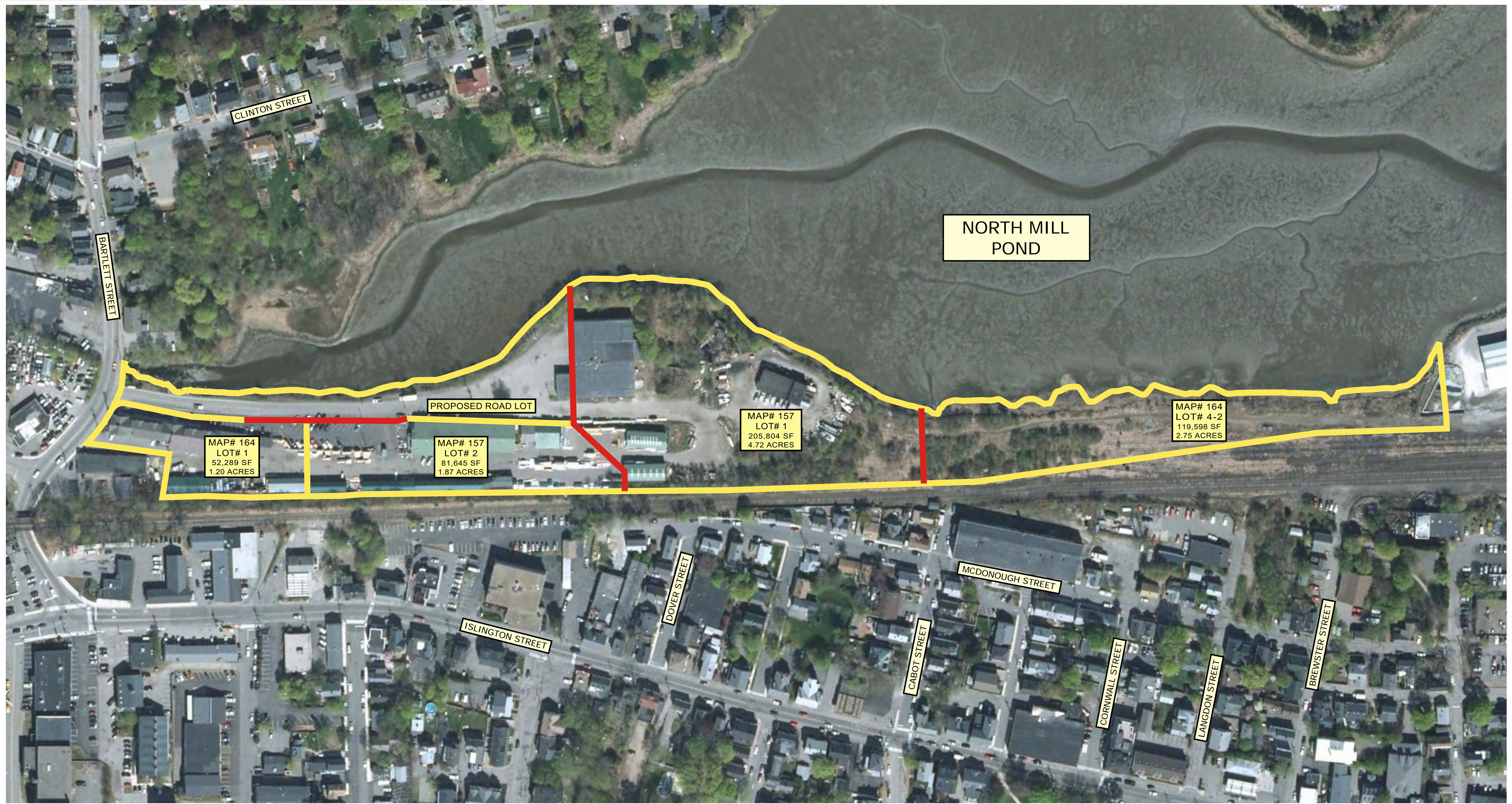
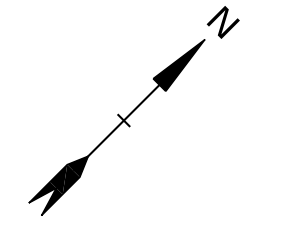

C:\0961\006_C-BOUNDARY.DWG Date Plotted: Jan 19, 2021 - 10:41am Plotted By: NANHANSEN

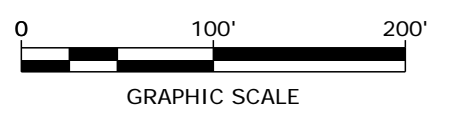

Tighe & Bond
 Engineers | Environmental Specialists
 177 Corporate Drive
 Portsmouth, New Hampshire 03801
 (603) 433-8818
 January 20, 2021

BARTLETT STREET WATER MAIN ABANDONMENT PLAN

PORTSMOUTH, NEW HAMPSHIRE

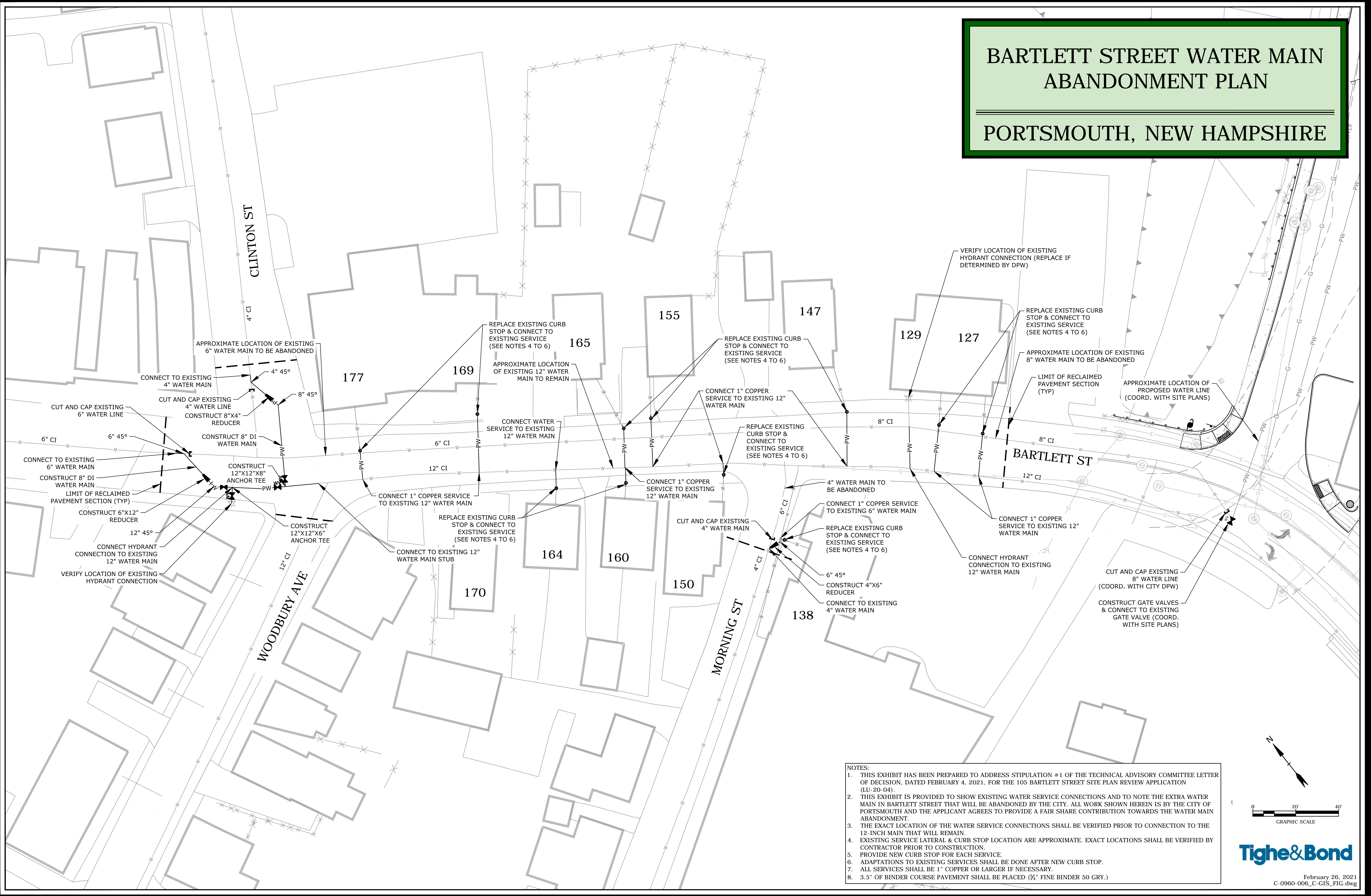

- NOTES:**
1. THIS EXHIBIT HAS BEEN PREPARED TO ADDRESS STIPULATION #1 OF THE TECHNICAL ADVISORY COMMITTEE LETTER OF DECISION, DATED FEBRUARY 4, 2021, FOR THE 105 BARTLETT STREET SITE PLAN REVIEW APPLICATION (LU-20-04).
 2. THIS EXHIBIT IS PROVIDED TO SHOW EXISTING WATER SERVICE CONNECTIONS AND TO NOTE THE EXTRA WATER MAIN IN BARTLETT STREET THAT WILL BE ABANDONED BY THE CITY. ALL WORK SHOWN HEREIN IS BY THE CITY OF PORTSMOUTH AND THE APPLICANT AGREES TO PROVIDE A FAIR SHARE CONTRIBUTION TOWARDS THE WATER MAIN ABANDONMENT.
 3. THE EXACT LOCATION OF THE WATER SERVICE CONNECTIONS SHALL BE VERIFIED PRIOR TO CONNECTION TO THE 12-INCH MAIN THAT WILL REMAIN.
 4. EXISTING SERVICE LATERAL & CURB STOP LOCATION ARE APPROXIMATE. EXACT LOCATIONS SHALL BE VERIFIED BY CONTRACTOR PRIOR TO CONSTRUCTION.
 5. PROVIDE NEW CURB STOP FOR EACH SERVICE.
 6. ADAPTATIONS TO EXISTING SERVICES SHALL BE DONE AFTER NEW CURB STOP.
 7. ALL SERVICES SHALL BE 1" COPPER OR LARGER IF NECESSARY.
 8. 3.5" OF BINDER COURSE PAVEMENT SHALL BE PLACED (3/4" FINE BINDER 50 GRY.)

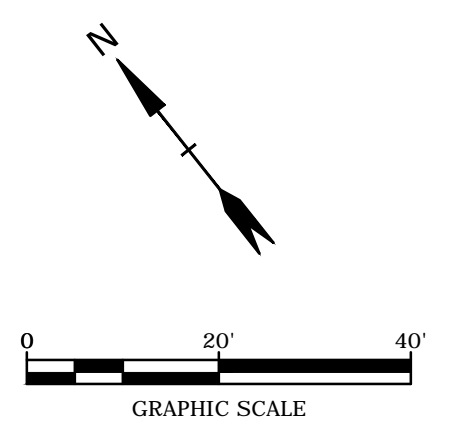

Tighe & Bond

February 26, 2021
C-0960-006_C-GIS_FIG.dwg

Last Save Date: February 26, 2021 9:32 AM By: NAHANSEN
 Plot Date: Friday, February 26, 2021 Plotted By: Neil A. Hansen
 T&B File Location: C:\Users\nahansen\Desktop\C-0960-006_C-GIS_FIG.dwg Layout Tab: WATER

MEMORANDUM

Ref: 1955A

To: Jeff Johnston
Cathartes

From: Stephen G. Pernaw, P.E., PTOE

Subject: Trip Generation Update

Date: February 21, 2020 (Updated December 23, 2020)

As you know, our office prepared the “*Traffic Impact & Site Access Study – Proposed Residential Subdivision*” report dated June 18, 2019 for the 120-unit multi-family low/mid-rise residential development located on the south side of North Mill Pond in Portsmouth, New Hampshire. The development proposal has changed and it now involves: 1) acquiring the property associated with Great Rhythm Brewing Company and the Play All Day Doggy Daycare facility and razing these buildings, 2) increasing the development area by +1.72 acres, and 3) increasing the number of dwellings to 152 units (see Attachment 1). Similar to our previous traffic report, all site vehicles will travel to/from the development via Bartlett Street. The purpose of this memorandum is to compare the trip generating characteristics of the former and current development proposals. The following tabulation compares these development proposals.

	Original Development Proposal	Current Development Proposal	Change
1. Apartments (units)	120	152	+32 units
2. Great Rhythm Brew ing Co	remains	razed	} - 68 AM & -85 PM trips
3. Play All Day dog care	remains	razed	
4. Access/Egress	Via Bartlett St. Only	Via Bartlett St. Only	No change
5. Development area	2.99 Acres	4.71 Acres	+58% increase

Table 1A summarizes the updated trip generation analyses and shows that the proposed residences will generate a total of approximately 52 (AM) and 66 (PM) vehicle-trips during the peak hour periods (see Attachment 2). Driveway counts conducted at the brewery/dog daycare parking lot in October 2018 revealed that these two uses generated 68 (AM) and 85 (PM) vehicle-trips on a typical weekday (see Attachment 3).

The current development proposal will generate approximately -57 (AM) and -72 (PM) fewer vehicle-trips during the peak hour periods than the previous development proposal. Accordingly, the traffic projections contained in the previous traffic study are now considered to be quite conservative on the “high side.”

Table 1A **Trip Generation Summary**
Current Development Proposal (12/23/20)

	Current Development Proposal			Original Development Proposal ³
	Apartments ¹ (152 units)	Less Brewery & Dog Daycare ²	Net Trips Generated	
Weekday AM Peak Hour				
Entering	14 veh	-34 veh	-20 veh	+11 veh
Exiting	<u>38 veh</u>	<u>-34 veh</u>	<u>4 veh</u>	<u>+30 veh</u>
Total	52 trips	-68 trips	-16 trips	+41 trips
Weekday PM Peak Hour				
Entering	40 veh	-43 veh	-3 veh	+32 veh
Exiting	<u>26 veh</u>	<u>-42 veh</u>	<u>-16 veh</u>	<u>+21 veh</u>
Total	66 trips	-85 trips	-19 trips	+53 trips

¹ITE Land Use Code 221- Multifamily Housing (Mid-Rise) - Equation Method - See Attachment 2

²October 2018 Driveway Counts - See Attachment 3

³See Attachments 4 & 5

Attachments

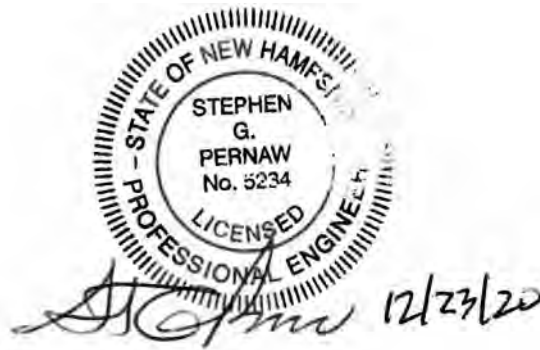

Trip Generation Summary

Alternative: Alternative 1
 Phase:
 Project: 1955A Gen 122220

Open Date: 12/22/2020
 Analysis Date: 12/22/2020

ITE	Land Use	Weekday Average Daily Trips			Weekday AM Peak Hour of Adjacent Street Traffic			Weekday PM Peak Hour of Adjacent Street Traffic		
		* Enter	Exit	Total	* Enter	Exit	Total	* Enter	Exit	Total
221	MID-RISE 1 EQUATION METHOD 152 Dwelling Units	414	413	827	14	38	52	40	26	66
	Unadjusted Volume	414	413	827	14	38	52	40	26	66
	Internal Capture Trips	0	0	0	0	0	0	0	0	0
	Pass-By Trips	0	0	0	0	0	0	0	0	0
	Volume Added to Adjacent Streets	414	413	827	14	38	52	40	26	66

Total Weekday Average Daily Trips Internal Capture = 0 Percent
 Total Weekday AM Peak Hour of Adjacent Street Traffic Internal Capture = 0 Percent
 Total Weekday PM Peak Hour of Adjacent Street Traffic Internal Capture = 0 Percent

* - Custom rate used for selected time period.

MEMORANDUM

Ref: 1821A

To: Juliet T. H. Walker, AICP
 Planning Director
 City of Portsmouth Planning Department

From: Stephen G. Pernaw, P.E., PTOE

Subject: Clipper Traders – Supplemental Traffic Counts
 Portsmouth, New Hampshire

Date: October 9, 2018

On October 2, 2018 the Technical Advisory Committee requested that traffic counts be conducted at the Great Rhythm Brewing Company & Play All Day dog day care center parking lot to determine when the busiest traffic periods occur. These traffic counts were conducted on Thursday, October 4, 2018 during the morning and evening commuter periods:

Hourly Volumes			
	<u>Arrivals</u>	<u>Departures</u>	<u>Trips</u>
7:00 - 8:00	32	29	61
8:00 - 9:00	<u>35</u>	<u>33</u>	<u>68</u>
2-Hour Total	67	62	129
3:00 - 4:00	22	14	36
4:00 - 5:00	34	37	71
5:00 - 6:00	<u>38</u>	<u>41</u>	<u>79</u>
3-Hour Total	94	92	186
AM Peak Hour Volumes			
7:30 - 8:30	34	34	68
8:00 - 9:00	35	33	68
PM Peak Hour Volumes			
4:15 - 5:15	43	42	85

The highest hourly traffic volume that was generated by this parking lot occurred from 4:15 to 5:15 PM with 43 arrivals and 42 departures (85 vehicle-trips).

cc: John Chagnon, P.E. – Ambit Engineering, Inc.
 Doug Pinciario, Clipper Traders, LLC
 Ed Hayes, Ricci Lumber
 Eric Eby, P.E. – City of Portsmouth
 Elizabeth Oltman, P.E. – The Engineering Corporation

TRIP GENERATION

To estimate the quantity of vehicle trips that will be produced by the proposed residential development, Pernaw & Company, Inc. considered the standardized trip-generation rates and equations published by the Institute of Transportation Engineers (ITE)¹. Based upon ITE Land Use Code LUC 221 – Multi-Family Housing (Mid-Rise) the overall development is expected to generate approximately 41 vehicle-trips during the weekday AM peak hour and 53 vehicle-trips during the weekday PM peak hour, on an average weekday basis. These results are based upon consideration of both the trip “rate” and “equation” method, and 120 dwelling units as the independent variable. The following table summarizes the anticipated trip-generating characteristics of the proposed residential development.

Table 1		Trip Generation Summary - Clipper Traders	
		120 Dwelling Units ¹	
Weekday Total ²			
	Entering	326 veh	
	Exiting	<u>326 veh</u>	
	Total	652 trips	
Weekday AM Peak Hour ²			
	Entering	11 veh	
	Exiting	<u>30 veh</u>	
	Total	41 trips	
Weekday PM Peak Hour ²			
	Entering	32 veh	
	Exiting	<u>21 veh</u>	
	Total	53 trips	

¹ ITE LUC 221 Multi-Family Housing (Mid-Rise)

² Trip Equation Method

³ Trip Rate Method

All vehicle-trips associated with the proposed residential development will be “primary” trips, or new trips to the area. Appendix F contains the trip generation computations for the proposed residential development, along with a diagram that summarizes the distribution of the primary trips at the various study area intersections.

¹ Institute of Transportation Engineers, *Trip Generation*, tenth edition (Washington, D.C., 2017).

Trip Generation Summary

Alternative: Previous Development Proposal

Phase:

Project: 1955A

Open Date: 6/25/2020

Analysis Date: 6/25/2020

ITE	Land Use	Weekday Average Daily Trips			Weekday AM Peak Hour of Adjacent Street Traffic			Weekday PM Peak Hour of Adjacent Street Traffic		
		* Enter	Exit	Total	* Enter	Exit	Total	* Enter	Exit	Total
221	MID-RISE 2	327	326	653	11	30	41	32	21	53
	120 Dwelling Units									
	Unadjusted Volume	327	326	653	11	30	41	32	21	53
	Internal Capture Trips	0	0	0	0	0	0	0	0	0
	Pass-By Trips	0	0	0	0	0	0	0	0	0
	Volume Added to Adjacent Streets	327	326	653	11	30	41	32	21	53

Total Weekday Average Daily Trips Internal Capture = 0 Percent

Total Weekday AM Peak Hour of Adjacent Street Traffic Internal Capture = 0 Percent

Total Weekday PM Peak Hour of Adjacent Street Traffic Internal Capture = 0 Percent

* - Custom rate used for selected time period.

Juliet T.H. Walker, AICP
Planning Director
City of Portsmouth Planning Department
City Hall, 3rd Floor
1 Junkins Avenue
Portsmouth, NH 03801

January 12, 2021

Ref. T0882.01

Re: 105 Bartlett Street – Residential Development – Updated Trip Generation Review

Dear Ms. Walker:

On behalf of the City of Portsmouth, TEC, Inc. (TEC) has reviewed additional documents as part of the transportation engineering peer review of a proposed residential development located on the north side of Bartlett Street, to the north of the existing Ricci Lumber property in Portsmouth. Subsequent to our prior review in 2018, the project size has changed from 120 apartment units to 152 apartment units. The property associated with the Great Rhythm Brewing Company and the Play All Day Doggy Daycare has been acquired and these land uses will be removed. One access will be provided from Bartlett Street. The alternative access originally proposed onto Maplewood Avenue has been removed.

The following documents were received as part of our review:

- Trip Generation Update Memorandum, prepared by Stephen G. Pernaw & Co., Inc, dated February 21, 2020 and revised December 23, 2020
- Clipper Traders – Supplemental Traffic Counts Memorandum, prepared by Stephen G. Pernaw & Co., Inc, dated October 9, 2018
- *Truck Turning Exhibit*, prepared by Tighe & Bond, revision dated November 18, 2020

TEC completed a review of these documents for the City of Portsmouth, and the following provides a summary of the comments that were compiled during our review:

1. The trip generation update memorandum uses data published in the industry standard Institute of Transportation Engineers' (ITE) publication *Trip Generation 10th Edition* to estimate the traffic generated by the proposed development. The memorandum uses data found under Land Use Code (LUC) 221 – Multi-Family Housing (Mid-Rise) for the apartment units. TEC concurs with this land use.
2. In 2018, the 120 apartment units within the original design proposal were projected to generate 41 trips during the morning peak hour and 53 trips during the evening peak hour. The Brewery and the Doggy Daycare facilities were proposed to be maintained

- in this scenario. Therefore, all residential trips were considered to be “new” to the adjacent roadway system.
3. It is generally accepted practice to consider the current or recent land uses on any site to be redeveloped and take credit for the existing trips generated by those land uses when projecting “new” traffic to be generated by a site. TEC concurs with the methodology presented within the updated memorandum.
 4. The Supplemental Counts Memorandum prepared in October 2018 indicates that the existing Great Rhythm Brewing Company and Play All Day Doggy Daycare facility generate 68 total vehicle trips during the weekday morning peak hour and 85 total vehicle trips during the weekday evening peak hour. With the current project proposal, these land uses are to be demolished and their trips would be removed from the driveway and the adjacent roadway system.
 5. The project as proposed is projected to generate 52 total vehicle trips during the weekday morning peak hour and 66 total vehicle trips during the weekday evening peak hour. The updated memorandum details the difference between the vehicle trips projected to be generated by the site and those generated by the previous land uses. The previous land uses generated more traffic than the current development proposal. Therefore, there is no traffic that would be considered “new” trips to the site or to the adjacent roadway system.
 6. The initial traffic memorandum prepared for this project site distributed some projected traffic to enter and exit the site via an access driveway to Maplewood Avenue. The project as proposed provides one access driveway onto Bartlett Street through the reconstructed existing driveway to Ricci Lumber, the Brewery and the Doggy Daycare facility. The alternative access originally proposed onto Maplewood Avenue has been removed. All site traffic will be required to use the existing driveway onto Bartlett Street, maintaining the existing conditions for vehicular access to the site.
 7. TEC concurs that with the removal of the existing land uses on the site, the trip generation projections, analyses, findings and conclusions detailed in the original traffic study and its addendum, prepared in 2018, remain a conservative representation of the impact of the project on the adjacent street system.
 8. Tighe & Bond provided a truck turning movement plan for the site driveway intersection with Bartlett Street. The site driveway is proposed to be reconstructed to provide tighter curb radii and a sidewalk connection to Bartlett Street. With this configuration, a WB-62, the largest tractor trailer used in design, will be able enter the site from the south on Bartlett Street, but will require the use of the entire driveway to perform the turning movement. The tractor trailers are shown exiting the site from the existing driveway to

- the south of the Ricci Lumber building and traveling toward the south on Bartlett Street. The Applicant should confirm that that delivery vehicles of this size will be restricted to enter and the exit the site to/from the south on Bartlett Street.
9. Tighe & Bond prepared a fire truck turning movement plan illustrating that a City of Portsmouth fire apparatus can circulate sufficiently throughout the site. TEC defers to the Portsmouth Fire Department whether this circulation plan is sufficient.
 10. Within the prior review, TEC recommended that the applicant provide a plan within the set that depicts the AASHTO minimum sight distance to/from the site access intersection onto Bartlett Street. The Applicant should commit to remove and maintain vegetation along the site frontage consistently to ensure that sight lines remain unobstructed at the site access intersection.

Please do not hesitate to contact me directly if you have any questions concerning our review at 603-601-8154. Thank you for your consideration.

Sincerely,
TEC, Inc.
"The **Engineering Corporation**"



Elizabeth Oltman, PE
Director of Transportation Planning



Cathartes
105 Bartlett Street Project
Portsmouth, NH

WETLAND DELINEATION AND ASSESSMENT OF FUNCTIONS AND VALUES

April 2020
Last Revised: March 2021

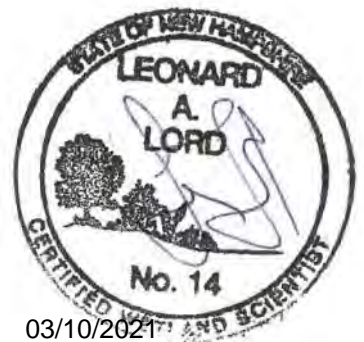

03/10/2021

1.0	Introduction	1
2.0	Methods.....	1
3.0	North Mill Pond	1
3.1	Ecological Integrity.....	2
3.2	Wildlife, Finfish, and Shellfish Habitat	2
3.3	Recreational and Commercial Potential.....	2
3.4	Aesthetic Quality	2
3.5	Educational Potential	3
3.6	Noteworthiness	3
4.0	North Mill Pond Tidal Buffer	3
4.1	Commercial Area Buffer	3
4.2	Disturbed Forest Buffer	4
4.3	Shrub Thicket Buffer.....	4
4.4	Buffer Impacts and Mitigation	4
5.0	Excavated Palustrine Forested Wetland	4
6.0	Summary	5

1.0 Introduction

The purpose of this report is to characterize wetlands and buffers in the vicinity of a proposed multi-family development at 105 Bartlett Street in Portsmouth, NH. The site is long and narrow and is located between an active railroad and North Mill Pond. It includes commercial buildings with paved and gravel parking areas, abandoned railroad structures, disturbed forest, and a dense shrub thicket. The area is highly disturbed, being originally filled by the railroad in the late 1800s.

2.0 Methods

On October 29 and December 2, 2019, Tighe & Bond reviewed and assessed 2,000+/- linear feet of tidal wetlands and buffers along the North Mill Pond. The review was limited to the vicinity of a proposed multi-family development, extending from Bartlett Street to an area opposite Cornwall Street, which runs roughly perpendicular to the parcel.

The wetland delineation review was based on criteria specified in the *Corps of Engineers Wetlands Delineation Manual, Technical Report Y-87-1* (January 1987), and the *Regional Supplement to the Corps of Engineers Wetland Delineation Manual: Northcentral and Northeast Region* (January 2012). The Highest Observable Tide Line was reviewed based on the definition found in NH Department of Environmental Services Wetland Rules, Env-Wt 101.49/Env-Wt 602.23. Wetlands were classified based on *Classification of Wetlands and Deepwater Habitats of the United States* (Cowardin et al., 1979).

The Highest Observable Tide Line (HOTL) had been previously delineated by another consulting firm in 2017. This line was reviewed by exporting the 2017 surveyed line into ArcGIS to overlay on an aerial photographic base map. This base map was then uploaded to an iPad and paired with a Trimble R1 submeter GPS for in-field verification. Using the iPad and GPS as a guide, the line was then evaluated in the field. The HOTL was deemed accurate and the previous 2017 delineation was accepted by Tighe & Bond. A previously unidentified freshwater wetland was also found within a six-foot +/- deep abandoned railroad turntable. Tighe & Bond delineated this area with sequentially numbered flagging and located the wetland boundary using the GPS technology described above.

Functions and values were assessed in the vicinity of the proposed project. Assessment methodologies were adapted from the *Maine Citizens Guide to Evaluating, Restoring, and Managing Tidal Marshes* (Bryan et al., 1997) and *The Highway Methodology Workbook Supplement—Wetland Functions and Values: A Descriptive Approach*, NAEPP-360-1-30a, US Army Corps of Engineers, New England Division, September 1999.

Photographs of the wetlands and buffers are provided in Appendix A.

3.0 North Mill Pond

North Mill Pond is a 79+/- acre tidal pond at the outlet of Hodgson Brook. It receives tidal flows under Maplewood Avenue at the northeast end of the pond. The pond consists predominantly of exposed mudflats at low tide, and is classified as Estuarine, Intertidal, Unconsolidated Shore, Mud, Regularly Flooded (E2US3N). A narrow band of salt marsh reaching up to 35+/- feet wide was identified between the mudflats and upland (Photo 1). The marsh is dominated by smooth cordgrass (*Spartina alterniflora*), with species such as

saltmeadow cordgrass (*Spartina patens*), sea lavender (*Limonium carolinianum*), and seaside goldenrod (*Solidago sempervirens*) more dominant toward the upland edge. This marsh area was classified as Estuarine, Intertidal, Emergent, Persistent, Regularly Flooded (E2EM1N).

North Mill Pond provides several important wetland functions and values, though many have been degraded by development and human activity. The following functions and values were assessed for the wetland in the vicinity of the proposed project.

3.1 Ecological Integrity

Ecological Integrity relates to how much the wetland has retained its native biotic and abiotic features and how these may have been degraded by human influences.

The Ecological Integrity of North Mill Pond has been compromised due to the presence of a tidal restriction, development of the upland buffer, water quality degradation, and filling along the project site. Efforts have been made in recent years to improve water quality entering the pond, improve tidal flushing, and restore some of the salt marshes. The peripheral salt marsh appears to be healthy and is comprised of native species along the project area.

3.2 Wildlife, Finfish, and Shellfish Habitat

The Wildlife, Finfish, and Shellfish Habitat function is the suitability of the habitat to support wildlife.

North Mill Pond contains extensive mudflats and a healthy but narrow peripheral salt marsh that contribute to wildlife habitat value. However, this value has been compromised by all the factors affecting Ecological Integrity described above. The area is likely to support a variety of wildlife, including migratory birds, finfish, and shellfish. Wildlife Action Plan mapping (Appendix B) depicts several small areas of the highest ranked wildlife value habitat around the pond. These high value habitats include two salt marsh areas in the vicinity of the proposed project; one directly across from the project and another just to the northeast of it.

3.3 Recreational and Commercial Potential

Recreational and Commercial Potential is the suitability of the wetland to support activities such as hiking, boating, hunting, bird watching, and shellfish harvesting.

North Mill Pond has the potential for use by small boats during high tide, though access appears to be limited to a boat launch on Marsh Lane, north of Maplewood Avenue. Shellfish harvesting is not allowed within the mudflats. Bird watching is a potential activity but public access is limited. There is an informal trail that runs through the proposed project area between Bartlett Street and Maplewood Avenue across private property that could be used for bird watching, but public access is not currently guaranteed. There is no visitor center, formally maintained trails, or access for disabled persons that would make this a more valuable area for recreation.

3.4 Aesthetic Quality

Aesthetic Quality refers to the ability of the wetland to provide interesting views and natural vistas.

The areas surrounding North Mill Pond are highly developed commercial and residential areas. There are few public viewing areas, but in locations where the pond can be seen it generally offers wide vistas and aesthetically pleasing views.

3.5 Educational Potential

Educational Potential consists of the ability of the wetland to serve as an outdoor classroom.

There is no safe public access to North Mill Pond near the project site. In addition to being private property, the project site has dangerous construction debris and steep banks to the pond, further diminishing the educational potential of this wetland.

3.6 Noteworthiness

Noteworthiness includes important qualities of the wetland not identified in previous functions, such as historic sites or unique natural features.

This area of North Mill Pond is noteworthy as it contains a salt marsh in a developed setting, which adds to its importance aesthetically and as part of the character of the area. In addition, the adjacent uplands have been proposed as part of the North Mill Pond Greenways project, which was presented to stakeholders in January 2019. (<https://www.cityofportsmouth.com/planportsmouth/north-mill-pond-trail-and-greenway>).

The wetland itself is not known for having any important historical features in the vicinity of the project area, though there have been historic structures and activities along its banks. The project area has some significance as the site of an old railroad yard with a turntable and roundhouse.

4.0 North Mill Pond Tidal Buffer

The North Mill Pond 100-foot tidal buffer can be divided into three zones within the project area: 1) a commercial area, including the Ricci Supply and Ace Hardware complex, the Great Rhythm Brewery building, a former railroad machine shop, and all the paved and unpaved impervious surfaces associated with those buildings; 2) the disturbed forest directly northeast and northwest of Great Rhythm Brewery, including the area around the old railroad turntable and roundhouse remains; and 3) the shrub thicket extending along the narrow portion of the parcel to the northeast. These areas all include historic filling 2-16 feet deep associated with railroad activities. The fill includes coal, coal ash, and possible slag.

4.1 Commercial Area Buffer

The commercial area (Photos 1-3) is comprised almost completely of impervious surfaces. These include buildings, paved and compact gravel parking lots, and a narrow strip of vegetation 10-20 feet wide extending down a steep bank to the tidal wetland. The vegetation includes lawn and species associated with disturbed sites such as staghorn sumac (*Rhus typhina*), autumn olive (*Elaeagnus umbellata*), black cherry (*Prunus serotina*), and Asiatic bittersweet (*Celastrus orbiculatus*). This area has little to offer in the way of functions and values other than contributing to stabilization of steep eroding

banks along the wetland. Runoff from this area likely contributes to the degraded water quality in North Mill Pond.

4.2 Disturbed Forest Buffer

The disturbed forested area northeast and southwest of Great Rhythm Brewery (Photos 4-6) is dominated by Norway Maple (*Acer platanoides*), black cherry, and staghorn sumac. The area includes significant rubble and debris as well as the railroad turntable and roundhouse remains. This area provides some screening for wildlife using the North Mill Pond and provides cover and food for small mammals and birds. However, it is dominated by invasive vegetation, and is highly disturbed by human activity.

4.3 Shrub Thicket Buffer

The shrub thicket northeast of the commercial area (Photos 7-8) is dominated by autumn olive with lesser amounts of staghorn sumac and other shrub species. This area provides wildlife habitat for small mammals and birds as well as screening for wildlife using North Mill Pond. Though invasive, the autumn olive provides prolific fruits utilized by birds and other frugivores. Bedding, clothing, campfire remains, trash, and other evidence suggests that this densely vegetated area has been used as camp sites by homeless individuals.

4.4 Buffer Impacts and Mitigation

The proposed project will not include any work within the 25-foot buffer to North Mill Pond. In addition, a 50-foot easement from the mean high water will be granted to the City of Portsmouth by the developer to build the North Mill Pond Trail and Greenway, which will provide improvements to the buffer, including invasive species management and revegetation with native species. Installation of the trail and greenway would result in improved functions and values of the wetland and buffer including: Ecological Integrity, Recreation Potential, Aesthetic Quality, and possibly Educational Potential. Existing impacts to the 100-foot buffer will be reduced from the trail and greenway improvements through the removal and restoration of impervious surfaces.

Table 4.1

105 Bartlett Street Multi-Family Development Buffer Impact Reductions

Overall Buffer Impact Area		
Wetland Buffer Setback	Existing Impact	Proposed Impact
0 - 25 FT	12,788 SF	6,788 SF
25 - 50 FT	30,478 SF	22,394 SF
50 - 100 FT	66,844 SF	52,543 SF
Total Impact	110,110 SF	81,725 SF
NET BUFFER IMPROVEMENT		28,385 SF

5.0 Excavated Palustrine Forested Wetland

A small wetland was delineated by Tighe & Bond within the base of the six-foot +/- deep, concrete walled railroad roundtable (Photos 9-10) within the disturbed forested area. The soils in this wetland are poorly drained marine silts and clays. The vegetation is dominated

by Norway maple and red osier dogwood (*Cornus sericea*). Nearby test pits identified approximately two to four feet of fill in the vicinity of the structure. Therefore, it is likely this wetland was at least partly excavated into native marine sediments during construction of the turntable. It is unclear if this area was originally a wetland or if the wetland was created by the excavation. This wetland was classified as Palustrine, Forested, Deciduous, Saturated (PFO1B). The small size of the wetland and its location within a man-made structure in a highly disturbed landscape has resulted in this system providing negligible wetland functions and values.

6.0 Summary

Two wetlands were delineated and evaluated on the site:

North Mill Pond is a 79+/- acre tidal wetland with expansive mud flats (E2US3N) and a narrow fringe of salt marsh (E2EM1N). Wetland functions and values are primarily Wildlife, Finfish, and Shellfish Habitat, as well as Aesthetic Quality and Noteworthiness. It is noteworthy as an important aesthetic component of the area and as an important potential site for a greenways trail project. It also has compromised but improving Ecological Integrity and some Recreation Potential. Upland buffers to the wetland have been compromised by development and invasive species, but limited vegetation does provide some screening for wildlife in the wetland.

A small excavated forested wetland (PFO1B) was identified within the old railroad turntable, approximately six feet below existing grade within a concrete wall. The small size of the wetland and its location within a man-made structure in a highly disturbed landscape has resulted in this system providing negligible wetland functions and values.

Tighe&Bond

APPENDIX A

Appendix A- Photographic Log

Client: Cathartes

Job Number: C-0960006

Site: 105 Bartlett St., Portsmouth, NH

Photograph No.: 1	Date: 10/29/19	Direction Taken: Northeast
Description: Salt marsh fringe along North Mill Pond at low tide opposite a commercial area in southwest portion of the site.		

Photograph No.: 2	Date: 10/29/19	Direction Taken: Northeast
Description: Paved buffer and eroding banks along North Mill Pond at low tide along the commercial area in southwest portion of the site.		

Appendix A- Photographic Log

Client: Cathartes

Job Number: C-0960006

Site: 105 Bartlett St., Portsmouth, NH

Photograph No.: 3	Date: 10/29/19	Direction Taken: Northeast
Description: Compact gravel drive and old railroad repair shop at the northern end of the commercial area with impervious surfaces.		
		

The photograph shows a gravel drive on the right side of the frame, leading towards a large, dark brick building with a partially open bay door. To the left of the drive is a chain-link fence, and beyond that, a body of water is visible under a cloudy sky. The trees in the background have some autumn-colored leaves.

Photograph No.: 4	Date: 10/29/19	Direction Taken: Northeast
Description: Buffer fill slope with rubble adjacent to a narrow salt marsh along the disturbed forest just northwest of the Great Rhythm Brewing Company.		
		

The photograph depicts a steep, disturbed slope covered in rubble, including large rocks, concrete blocks, and weathered wooden beams. The ground is littered with fallen leaves. To the left, a narrow salt marsh with tall grasses is visible, and in the background, a body of water and some buildings can be seen under an overcast sky.

Appendix A- Photographic Log

Client: Cathartes

Job Number: C-0960006

Site: 105 Bartlett St., Portsmouth, NH

Photograph No.: 5	Date: 10/29/19	Direction Taken: Southwest
--------------------------	-----------------------	-----------------------------------

Description: Lawn and disturbed forest buffer northwest of the Great Rhythm Brewing Company.



Photograph No.: 6	Date: 10/29/19	Direction Taken: East
--------------------------	-----------------------	------------------------------

Description: Remains of the railroad roundhouse and disturbed forest buffer northeast of the Great Rhythm Brewing Company.



Appendix A- Photographic Log

Client: Cathartes

Job Number: C-0960006

Site: 105 Bartlett St., Portsmouth, NH

Photograph No.: 7	Date: 10/29/19	Direction Taken: Northeast
--------------------------	-----------------------	-----------------------------------

Description: Shrub thicket and existing informal trail at the northeast end of the proposed project area.



Photograph No.: 8	Date: 10/29/19	Direction Taken: Northeast
--------------------------	-----------------------	-----------------------------------

Description: Evidence of use as camp sites by homeless individuals within the shrub thicket at the northeast end of the project area.



Appendix A- Photographic Log

Client: Cathartes

Job Number: C-0960006

Site: 105 Bartlett St., Portsmouth, NH

Photograph No.: 9	Date: 12/2/19	Direction Taken: South
--------------------------	----------------------	-------------------------------

Description: Wetland dominated by Norway maple and red osier dogwood within the old railroad turntable approximately six feet below grade.



Photograph No.: 10	Date: 12/2/19	Direction Taken: n/a
---------------------------	----------------------	-----------------------------

Description: Poorly drained marine silts and clays observed in the bottom of the old railroad turntable.



Tighe&Bond

APPENDIX B

2015 HIGHEST RANKED WILDLIFE HABITAT BY ECOLOGICAL CONDITION

 Highest Ranked Habitat in New Hampshire

 Highest Ranked Habitat in the Biological Region

Biological region = TNC ecoregional subsection for terrestrial habitats or Aquatic Resource Mitigation region for wetlands and floodplain forest.

 Supporting Landscapes

 Conservation or public

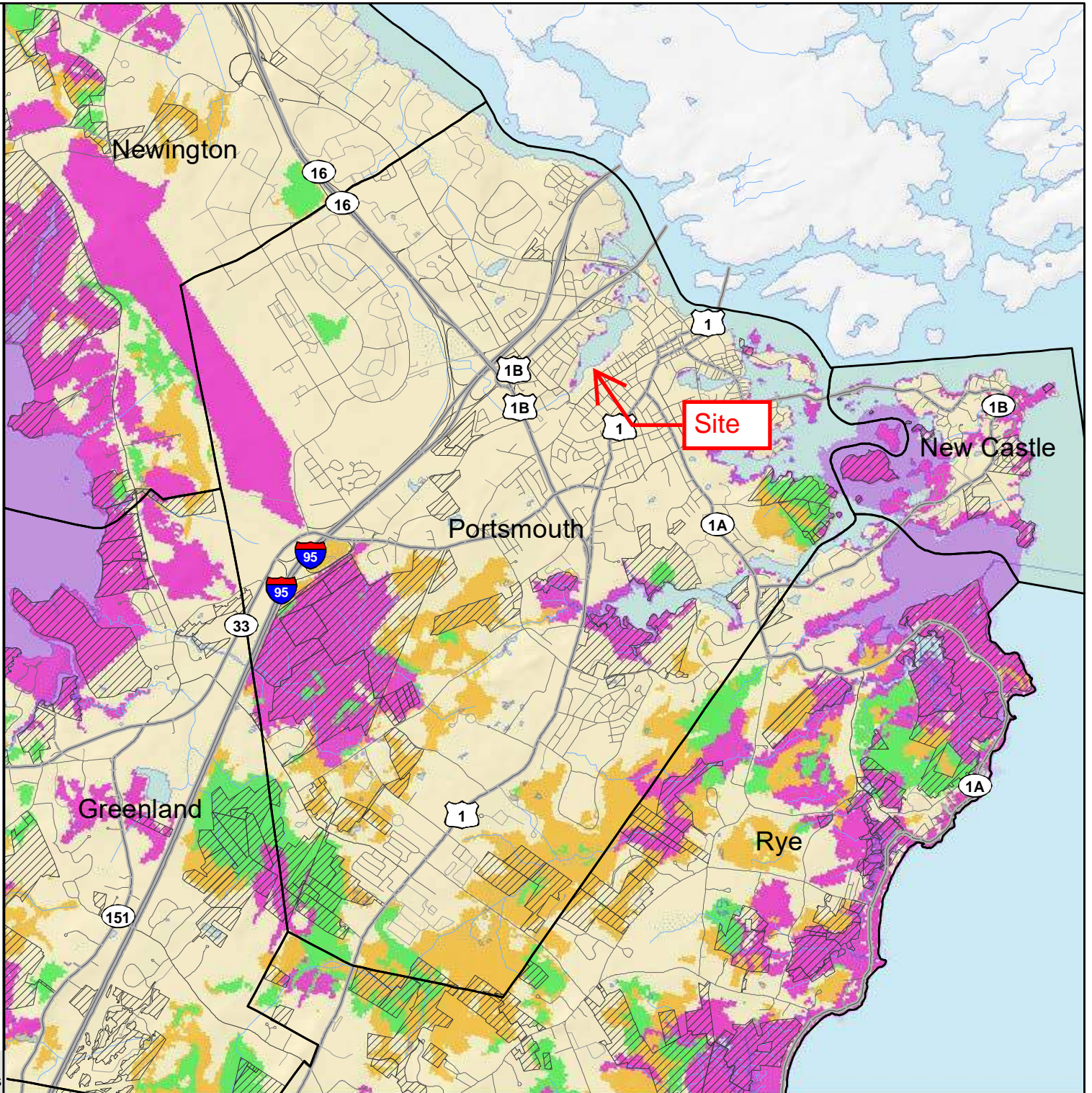

Base map data provided by NH GRANIT at UNH September 2019. Intended for planning use only.



0 1 2 Kilometers

0 1 2 Miles



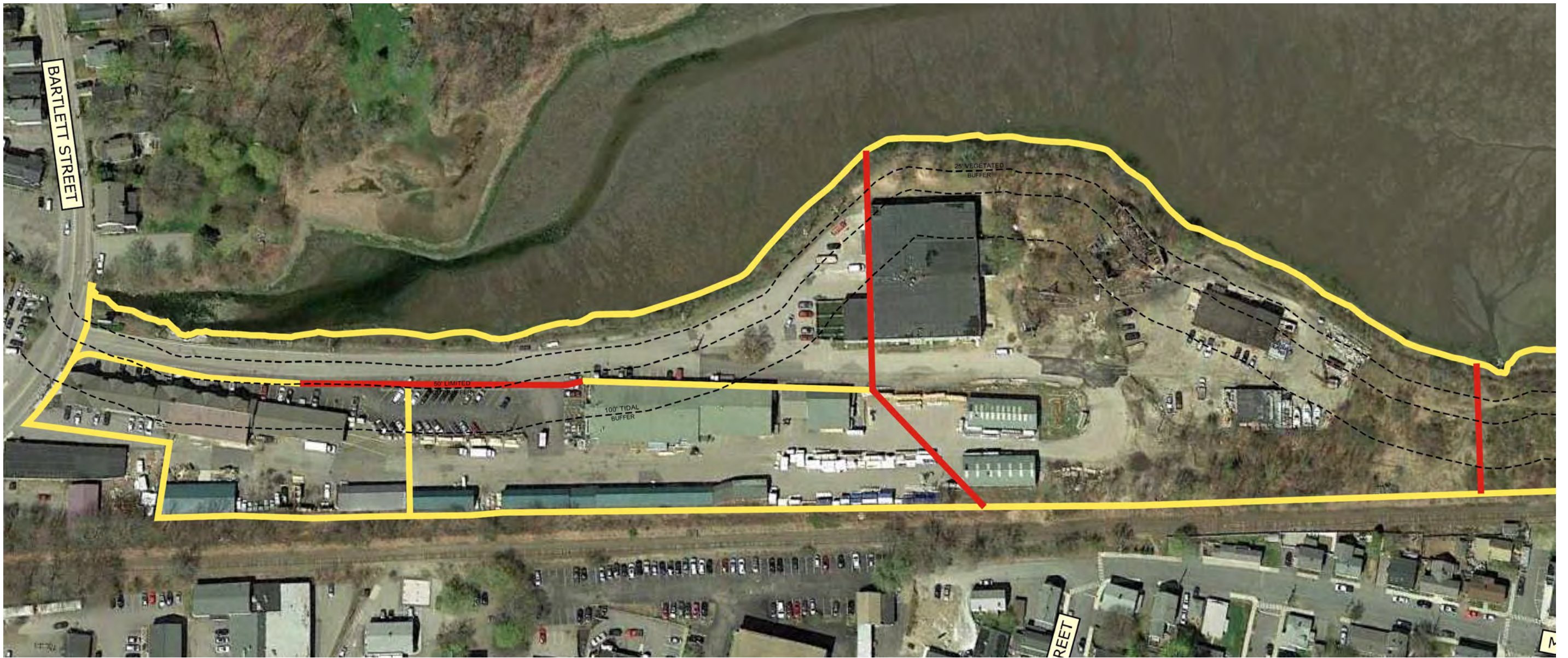

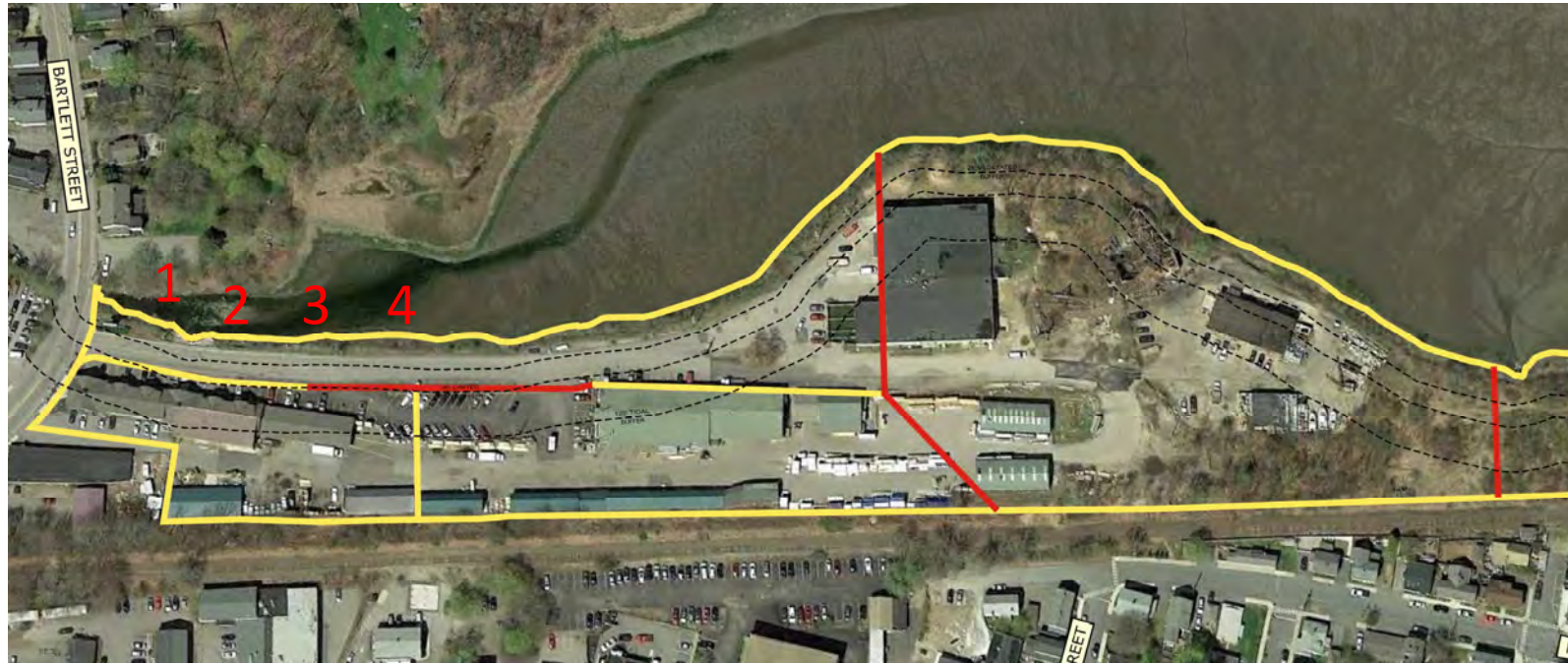

1 Ash



2

Multiflora Rose



3

Bittersweet



4 Eastern Red Cedar

105 Bartlett – Existing Vegetation & Invasive Species in 100’ Buffer - Photos

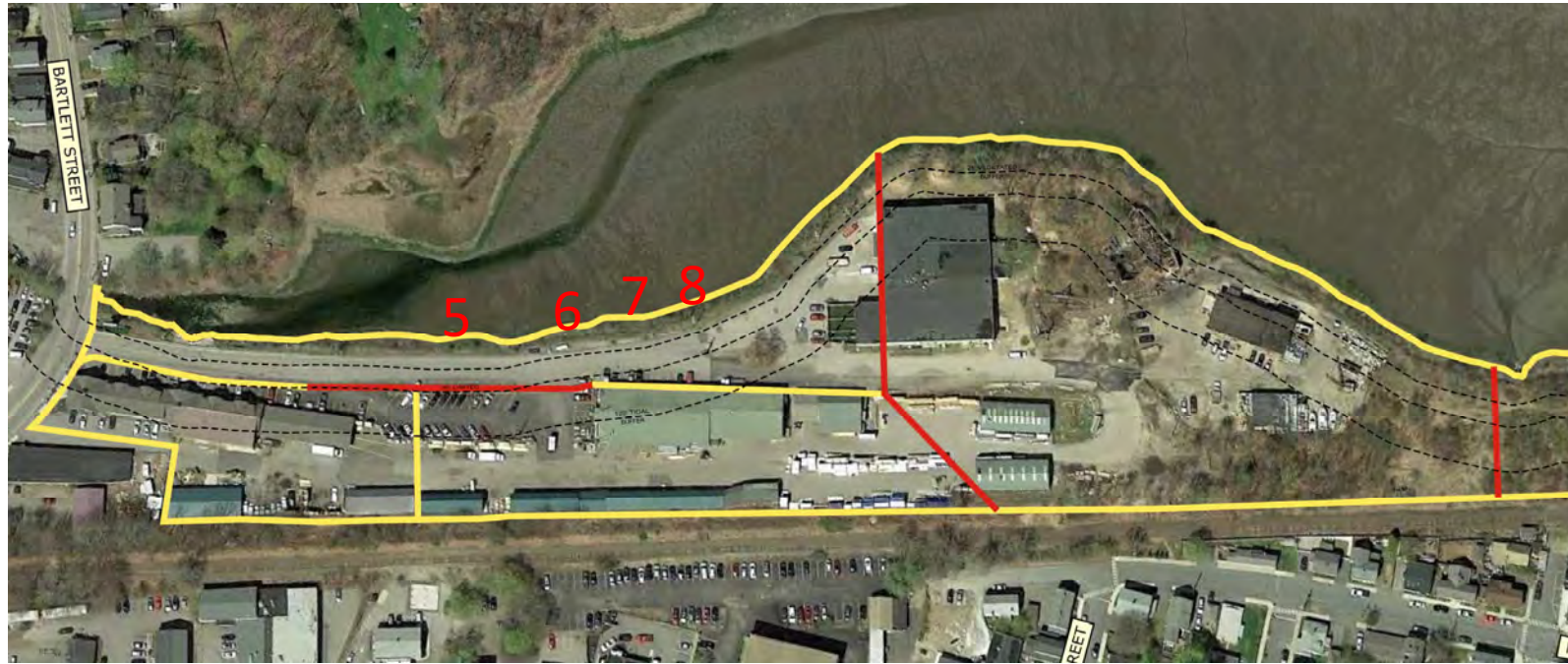

Sumac & Ash
5



6

Ash and Buckthorn



7 Ash and Buckthorn



8 Buckthorn

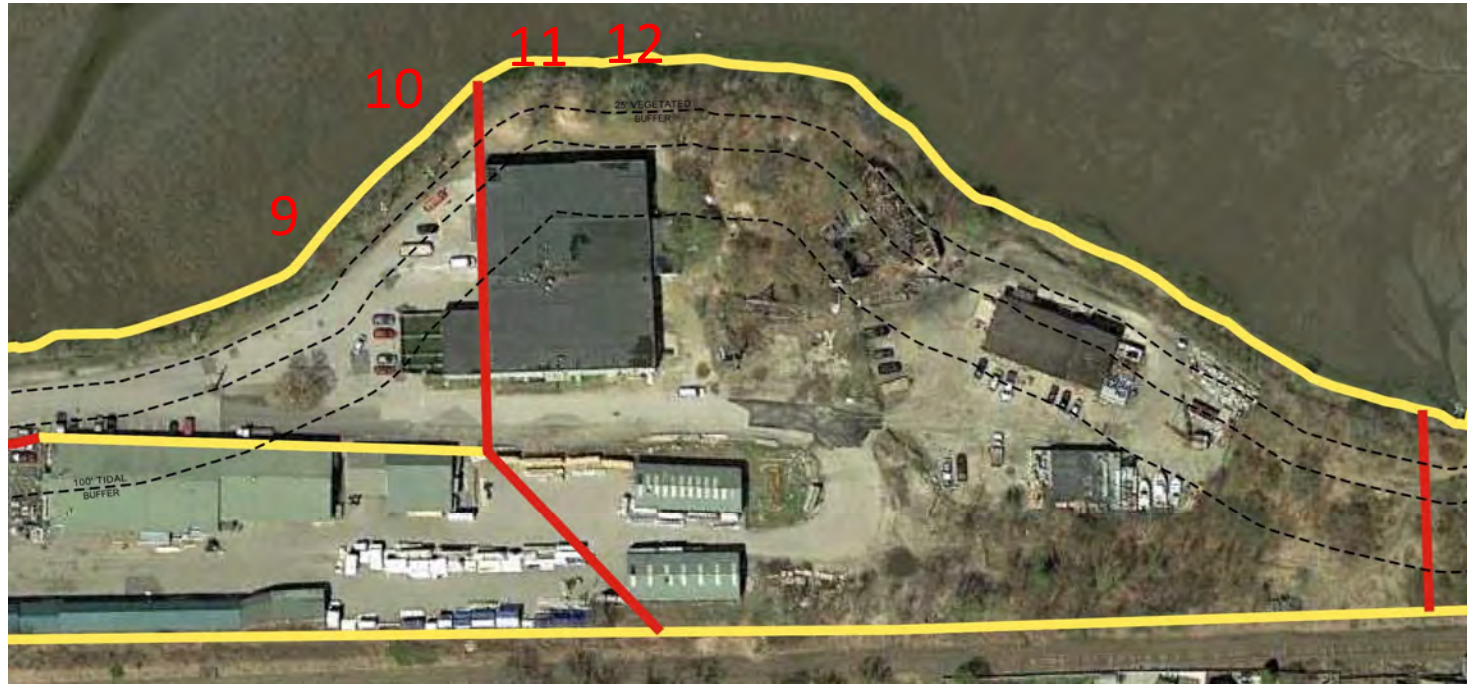

Multiflora rose,
Crabapple,
Dogwood,
Buckthorn

9



Norway Maple, Rhus aromatica 10



Norway Maple, Buckthorn,
Cottonwoods 11



Norway
Maple

12



Norway Maples
Red Oak
13



Buckthorn, Crabapple,
Norway Maples,
Cottonwoods, Autumn Olive
14



Cottonwoods



15
16
105 Bartlett – Existing Vegetation & Invasive Species in 100' Buffer - Photos



Cherry, Norway
Maple, Buckthorn

17



18 Cottonwood, Norway
Maple, Buckthorn



19



20



21



22

Norway Maple, Sumac
Red Oak



23

Ash, Cottonwood

105 Bartlett – Existing Vegetation & Invasive Species in 100' Buffer - Photos



Gravel, Scrub, Norway Maples, Cottonwood beyond

24



Cottonwood & Birch

25



Open Gravel

26

C-0960-006
November 4, 2020

Mr. Jeff Johnston, Principal
Cathartes
100 Summer Street, Suite 1600
Boston, MA 02110

Re: **Environmental Summary**
105 Bartlett Street
Portsmouth, New Hampshire

Dear Mr. Johnston:

Tighe & Bond conducted an environmental assessment in 2019 for the 105 Bartlett Street, New Hampshire property (herein referred to as the "Site") on behalf of Cathartes. Tighe & Bond conducted a limited subsurface exploration program to help assess the subsurface conditions potentially impacted by historical operations and to better understand potential environmental risks associated with property acquisition and redevelopment.

Below is a summary of potential environmental concerns associated with the Site identified during this limited environmental assessment:

- Tighe & Bond completed an Environmental Site Assessment which included visual field observations of soil and the collection and chemical analysis of both soil and ground water samples across the Site.
 - A total of ten(10) environmental soil samples were collected across the Site and submitted for a comprehensive chemical analysis of volatile organic compounds (VOCs), semi-volatile organic compounds (SVOCs), total petroleum hydrocarbons (TPH), polychlorinated biphenyl (PCBs), RCRA 8 Metals and reactivity.
 - A total of four(4) groundwater samples were collected across the Site and submitted for a comprehensive chemical analysis of VOCs, SVOCs and dissolved RCRA 8 metals.
- Tighe & Bond concluded that in general, portions of the site are underlain with a layer of anthropogenic fill material at varying thickness which is attributed to the historic site use. The anthropogenic fil material is generally consistent with typical urban sites with similar commercial/industrial historical site uses.
- Portions of the Site were formerly utilized for B&M railroad operations and a foundry. The presence of coal tar was not observed in test pits, and/or the soil and groundwater data collected at the site to date.
- Analytical data from soil samples collected during the 2019 subsurface investigations indicate concentrations of contaminants are typical for similar urban sites are considered background conditions from the anthropogenic fill material at the Site and do not constitute a NHDES reporting condition.

105 Bartlett Street
Portsmouth, New Hampshire

November 2020

Analytical data obtained from the 2019 groundwater sampling at the Site indicate no exceedances of the NHDES groundwater standards were observed.

- A 20,000 gallon tank was removed from the site in 1992. The soil in this area has limited petroleum contaminants in soil. This area will be remediated under a soil management plan and in accordance with NHDES regulations during redevelopment.

If you have any questions pertaining to this limited subsurface investigation, please feel free to contact the undersigned.

Very truly yours,

TIGHE & BOND, INC.



Bryan Gammons
Senior Environmental Scientist

\\Tighebond.com\data\Data\Projects\C\C0960 Cathartes\C-0960-006 105 Bartlett Street\Environmental\Reports\Environmental Memo - November 2020\2020-1104-105 Bartlett Street - Environmental Memo-Final.doc

C-0960-006
January 20, 2021

Re: **Water and Sewer Demand Summary**
Proposed Multi-Family Development, 105 Bartlett Street, Portsmouth, NH

The following is the estimated water service for the Multi-Family Development located at 105 Bartlett Street, Portsmouth NH.

Estimated Water Demand

Anticipated Design Flows Table		
Proposed Use	Units	Total
Residential Units:		
Studio	27 Units	3,240 GPD
1 Bedroom	52 Units	6,240 GPD
2 Bedroom	57 Units	13,680 GPD
3 Bedroom	16 Units	5,760 GPD
	Total Flow	28,920 GPD

J:\C\C0960 Cathartes\C-0960-006 105 Bartlett Street\Report_Evaluation\Applications\City Of Portsmouth\20210120 TAC Resubmission\Estimated Water Demand.Docx





May 20, 2020

Neil A. Hansen, PE
Tighe & Bond, Inc.
177 Corporate Drive
Portsmouth, NH 03801

1700 Lafayette Road
Portsmouth, NH 03801

Michael J Busby
603-436-7708 x555-5678
michael.busby@eversource.com

Dear Mr. Hansen:

I am responding to your request to confirm the availability of electric service for the proposed 105 Bartlett Street project being constructed for/by Iron Horse Properties, LLC.

The proposed project consists of three (3), 4-story buildings with 174 residential units and approximately 10,000 s/f of office space at the ground level and parking below grade. The proposed development will be constructed off Bartlett Street.

The developer will be responsible for the installation of all underground facilities and infrastructure required to service the new building. The service will be as shown on attached marked up Utility Plans C-104.1 & C-104.2. The proposed building service will be fed from Bartlett St, to be determined by Eversource Engineering as depicted on Utility Plans C-104.1 & C-104.2. The developer will work with Eversource to obtain all necessary easements and licenses for the proposed overhead/underground facilities listed above.

This letter serves as confirmation that Eversource has sufficient capacity in the area to provide service to this proposed development. The cost of extending service to the aforementioned location and any associated infrastructure improvements necessary to provide service will be borne by the developer unless otherwise agreed upon.

The attached drawing titled "Proposed Multi-Family Development Utilities Plan" dated 04/20/2020, shows transformer locations to service your proposed project.

Eversource approves the locations shown; assuming the final installed locations meet all clearances, physical protection, and access requirements as outlined in Eversource's "Information & Requirements For Electric Supply" (<https://www.eversource.com/content/docs/default-source/pdfs/requirements-for-electric-service-connections.pdf?sfvrsn=2>).

If you require additional information or I can be of further assistance please do not hesitate to contact me at our Portsmouth Office, 603-436-7708 Ext. 555-5678

Respectfully,

Michael J. Busby, PE
NH Eastern Regional Engineering and Design Manager, Eversource

cc: (via e-mail)
Michael Lee, Eastern Region Operations Manager, Eversource
Mary Jo Hanson, Field Supervisor, Electric Design, Eversource



April 17, 2020

Ed Hayes
Iron Horse Properties
105 Bartlett St
Portsmouth NH 03801

RE: Natural Gas Availability to 105 Bartlett St Portsmouth NH

Dear Ed,

Unitil's natural gas division has reviewed the requested site for natural gas service.

Unitil hereby confirms natural gas service will be available to the 105 Bartlett St Portsmouth project to serve 174 apartments.

Installation is pending an authorized installation agreement with Iron Horse Properties and street opening approval from the City of Portsmouth DPW.

Let me know if you have any questions. You can email me at oliver@unitil.com. My phone number is 603-294-5174.

Sincerely,

Janet Oliver
Senior Business Development Representative



Waste Management
90 Rochester Neck Rd
Rochester, NH 03839

February 9, 2021

Jackie Huber
CATHARTES
11 Beacon St
Ste 1120
Boston, MA 02108

Dear Jackie:

As requested, I've outlined the waste removal plan for the future development at Residences at Islington Creek, Portsmouth, NH. Using the volume assumptions for a 152 unit residential community with centralized waste and recycling containers, the service below would provide sufficient capacity for a community this size.

Trash Service-

One 10yd solid waste container- serviced three times per week

Recycling Service-

One 10yd single stream recycling container- serviced one time per week

Industry standards estimate on average .25 yds per household per week are generated, which is equivalent to 4-13 gallon trash bags per household per week. The plan above allows .26 yards per household per week.

Please let me know if you need any additional information.

Sincerely,

Allyson Garcelon
Major Account Manager
Waste Management of New Hampshire, Inc
agarcelon@wm.com
(c) 207.252.3086

March 9, 2021

City of Portsmouth Planning Board

GREEN BUILDING STATEMENT

Re: Proposed Apartments at Islington Creek, 105 Bartlett Street, Portsmouth NH

The core and shell of the proposed new apartment buildings at 105 Bartlett Street is being designed to meet or exceed current Energy Code requirements. A U.S. Department of Energy "COMcheck" will be submitted with the building permit application.

Currently the State of New Hampshire has adopted the 2015 International Energy Conservation Code with amendments, and the design of the new building will be built to current best practices and will exceed these requirements when appropriate.

- Foundation system to be cast in place concrete with continuous rigid insulation installed to depths required by the energy code. Continuous insulation to be provided under the concrete slab on grade for 2 feet along the exterior wall.
- Exterior walls to have continuous insulation outside the framing system and the continuous air barrier, to provide better overall thermal performance. Exterior skin of building to be a combination of masonry (brick and cast stone, cementitious siding panels, and metal wall panel screen walls that provide an air space in front of the insulation to allow for moisture management.
- Exterior Windows to have thermally broken aluminum framing for common spaces and Vinyl windows at Apartment units. All glazing to be insulated, high-performance type to provide enhanced thermal performance and solar control.
- Roofing system: Light colored membrane roofing system over continuous rigid insulation that exceeds the base energy code requirements.
- HVAC systems for the apartment units to consist of high-efficiency, variable refrigerant flow, split system heat pumps. Ventilation to be provided by high-efficiency DX gas, dedicated outdoor units to provide fresh air to apartment units and common spaces. Bathroom exhaust to run through energy recovery heat exchanger to preheat incoming makeup air. Domestic hot water to be provided by high efficiency condensing boilers with variable frequency pumps. Apartment units to have individual temperature controls and common spaces to have digital controls with occupancy sensors. Underground parking to have variable speed ventilation fans with carbon monoxide detectors.
- Plumbing: All fixtures to be low flow.
- Lighting: Exterior lighting to be LED cutoff fixtures for energy efficiency and to minimize light pollution. All interior lighting to be LED throughout using less than 1 watt / sf. Occupancy sensors to be utilized as required by code.
- Landscaping: local species that are drought tolerant to be incorporated into plantings list.

Sincerely,



A. Matthew Wirth
Senior Vice President - Architecture and Engineering



LED POST TOP

Specifications and Features:

Radiant™ LED

- Conformal Coating LED light engine
- CCT: 2700, 3000, 4000, 5000
- IP66

Optical

- Types II, III, IV, V

Electrical

- Electronic Driver, 120-277V, 50/60Hz or 347/480V, 50/60Hz
- 0-10V Dimmable Driver
- Surge Protection included
 - surge protection device meets IEEE C62.41 2002 C High 10kA

Controls

- Button eye photo control (PC)

Housing

- The hinged roof opens with one fastener for ease of relamping, 3" slip fitter.
- Standard Southgate comes with 2 struts. Optional 4 struts are available as an adder.

Finish

- Super durable polyester powder coat finish over a chromate conversion coating. Custom finishes available, including patinas and all RAL colors.

Listings & Ratings

- ETL listed to UL 1598 standard for wet location and IP66

Warranty

- 5 year limited warranty



Two Struts (standard)
No Lens/Globe



Two Struts (standard)
with Globe



Optional 4 Struts
No Lens/Globe



Optional 4 Struts
with Globe

EPA: 3.0
WEIGHT: 42 lbs (max.)

ORDERING FORMAT

Example: SOUTH-FA-70W3K-U-5-N-BK



SOUTH			
Model	Globe/Lens	LED Module	Voltage
SOUTH=Southgate Radiant™	NL=No Lens CA=Clear Acrylic TG=Clear Tempered Glass	See Chart - LED Light Engine Specifications.	U=120-277V H=347/480V
Distribution	Options	Finish	
2=Type II 3=Type III 4=Type IV 5=Type V	FS=Fuse, Single PC=Button eye photo control 4S=Four Struts N=None	Standard Colors BK=Black BZ=Bronze DBZ=Dark Bronze WH=White	Standard Colors GR=Green SM=Silver Metallic GY=Light Grey TBK=Textured Black CC=Custom (Consult Factory)



LED POST TOP



13" Radiant™



12" Radiant™



8" Radiant™

RADIANT™

LED LIGHT ENGINE SPECIFICATIONS:

LED Module	Wattage	Nominal Lumens*	System Efficacy	CCT	CRI	IES Distributions
40W5K	40	4,396	109.9	5000K	85	Type II, III, IV, V
50W5K	50	5,495	109.9	5000K	85	Type II, III, IV, V
60W5K	60	6,594	109.9	5000K	85	Type II, III, IV, V
70W5K	70	7,693	109.9	5000K	85	Type II, III, IV, V
80W5K	80	8,792	109.9	5000K	85	Type II, III, IV, V
90W5K	90	9,891	109.9	5000K	85	Type II, III, IV, V
105W5K	105	11,540	109.9	5000K	85	Type II, III, IV, V
120W5K	120	13,188	109.9	5000K	85	Type II, III, IV, V
135W5K	135	14,837	109.9	5000K	85	Type II, III, IV, V
40W4K	40	4,396	109.9	4000K	85	Type II, III, IV, V
50W4K	50	5,495	109.9	4000K	85	Type II, III, IV, V
60W4K	60	6,594	109.9	4000K	85	Type II, III, IV, V
70W4K	70	7,693	109.9	4000K	85	Type II, III, IV, V
80W4K	80	8,792	109.9	4000K	85	Type II, III, IV, V
90W4K	90	9,891	109.9	4000K	85	Type II, III, IV, V
105W4K	105	11,540	109.9	4000K	85	Type II, III, IV, V
120W4K	120	13,188	109.9	4000K	85	Type II, III, IV, V
135W4K	135	14,837	109.9	4000K	85	Type II, III, IV, V
40W3K	40	4,396	109.9	3000K	85	Type II, III, IV, V
50W3K	50	5,495	109.9	3000K	85	Type II, III, IV, V
60W3K	60	6,594	109.9	3000K	85	Type II, III, IV, V
70W3K	70	7,693	109.9	3000K	85	Type II, III, IV, V
80W3K	80	8,792	109.9	3000K	85	Type II, III, IV, V
90W3K	90	9,891	109.9	3000K	85	Type II, III, IV, V
105W3K	105	11,540	109.9	3000K	85	Type II, III, IV, V
120W3K	120	13,188	109.9	3000K	85	Type II, III, IV, V
135W3K	135	14,837	109.9	3000K	85	Type II, III, IV, V

*Please refer to the fixture's IES file for detailed information. Subject to change.



LED POST TOP

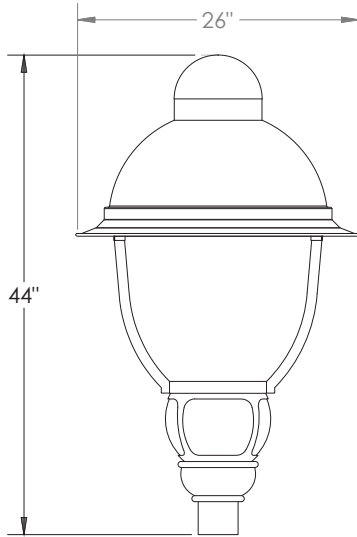

Two Struts (standard)
No Lens/Globe

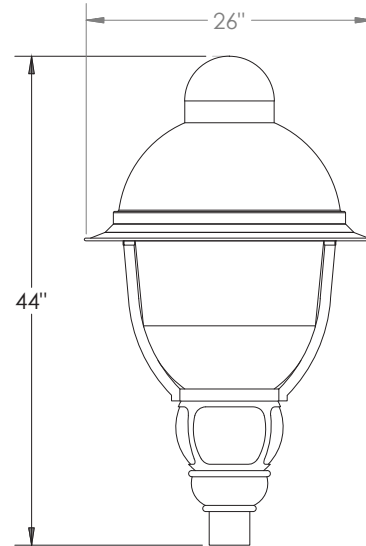

Two Struts (standard)
with Globe

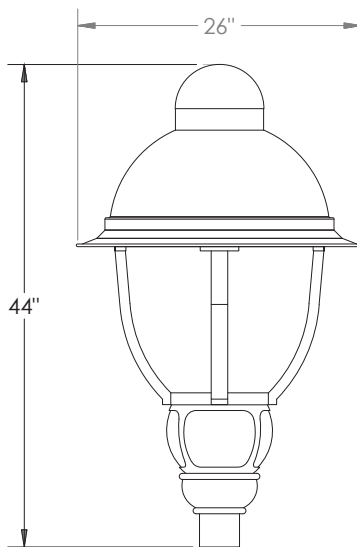

Optional 4 Struts
No Lens/Globe

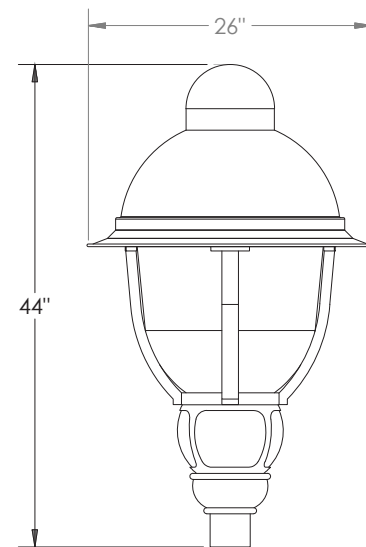

Optional 4 Struts
with Globe



BOLLARD LIGHTING



Specifications and Features:

Radiant™ LED

- Conformal Coating LED light engine
- CCT: 2700, 3000, 4000, 5000K

Optical

- Type II, III, IV, V

Electrical

- Electronic Driver, 120-277V, 50/60Hz or 347/480V, 50/60Hz
- 0-10V Dimmable Driver
- Surge Protection
 - surge protection device meets IEEE C62.41 2002 C High 10kA

Controls (adder)

- Button eye photo control (PC)

Housing

- The bollard is heavy gauge decorative cast aluminum.

Finish

- Super durable polyester powder coat finish over a chromate conversion coating. Custom finishes available, including patinas and all RAL colors.

Listings & Ratings

- ETL listed to UL 1598 standard for wet location

Warranty

- 5 year limited warranty



ORDERING FORMAT

Example: CAV414-LT-FA-10W27K-U-5-N-BK

Model	Style	Lens	LED Module	Voltage	Distribution
CAV414					
CAV414=CAV414	NI=Non-Illuminated LT=Lantern Top	CA=Clear Acrylic WA=White (Opal) Acrylic FA=Frosted Acrylic AM=Amber LED	See Chart - LED Light Engine Specifications.	U=120-277V H=347/480V	2=Type II 3=Type III 4=Type IV 5=Type V
Options				Finish	
N=None	BT=Ball Top	DT=Dome Top	Standard Colors	Standard Colors	
FS=Fuse, Single	AF=Acorn Finial	GFI=Ground Fault Interrupter (outlet supplied by others;specify location)	BK=Black	GR=Green	CC=Custom
PC=Button eye photo control	USB=Dual USB port (specify location)		BZ=Bronze	SM=Silver Metallic	(Consult Factory)
H=House Side Shield			DBZ=Dark Bronze	GY=Light Grey	
EB=Eyebolt mounted on bollard (specify location)			WH=White	TBK=Textured Black	



BOLLARD LIGHTING

LANTERN TOP LED LIGHT ENGINE SPECIFICATIONS:

6" Radiant Lumen Chart						
Initial lumen data						
CCT	LED Module	Input Watts	Type 2	Type 3	Type 4	Type 5
5K	10W5K	10	1217	1186	1204	1190
	15W5K	15	1826	1780	1806	1785
	20W5K	20	2434	2373	2408	2380
4K	10W4K	10	1175	1145	1162	1148
	15W4K	15	1762	1717	1743	1723
	20W4K	20	2349	2290	2324	2297
3K	10W3K	10	1132	1103	1120	1107
	15W3K	15	1698	1655	1680	1660
	20W3K	20	2264	2207	2240	2213
27K	10W27K	10	1098	1070	1086	1073
	15W27K	15	1647	1605	1629	1610
	20W27K	20	2196	2141	2172	2147

This chart indicates INITIAL LUMENS. Lens choice will affect lumen output.

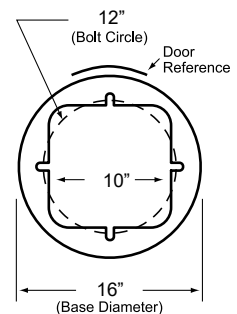
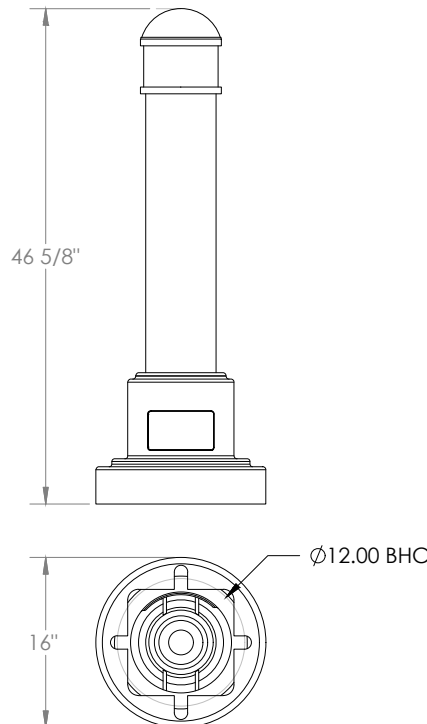
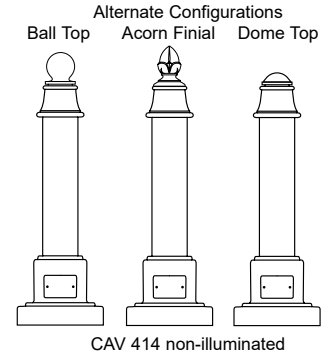



WALL MOUNT LIGHTING

L70
 25°C **89,000 Hours**

LED Up/Down Compass LED Wall Cylinder

- Lens:**
Tempered Clear Flat Glass Lenses.
- Reflector:**
Wide, Medium and Narrow Distributions.
- Mounting Options:**
Mount Over a 4" Recessed Outlet Box.
- COB LED:**
Cool Copper COB
- Wattage:**
COB 40w, System Input 40w
(100w HID Equivalent)
- Driver:**
Electronic Driver, 120-277V, 50/60Hz; Dimmable Driver
- Warranty:**
5-Year Warranty for -40°C to +50°C Environment.
See Page 2 for Projected Lumen Maintenance Table.



Shown with "A"
 Medium Optic

Shown with "D"
 Narrow Optic

The Pemco CMPRD Turbine architectural wall cylinder provides up/down lighting with narrow, medium and wide distributions designed to replace HID lighting systems from 100w MH or HPS. Typical wall mounted lighting applications include retail centers, industrial parks, schools and universities, public transit and airports, office buildings and medical facilities. Mounting heights of 8 to 16 feet can be used based on light level and uniformity requirements.

Specifications and Features:

Housing:
 Extruded Round Aluminum Housing with Built-in Heat Sinks.

Listing & Ratings:
 CSA: Listed for Wet Locations, ANSI/UL 1598, 8750
 IP65 Sealed LED Compartment.

Finish:
 Textured Architectural Bronze or Black Powdercoat Finish Over a Chromate Conversion Coating. Custom Colors Available Upon Request.

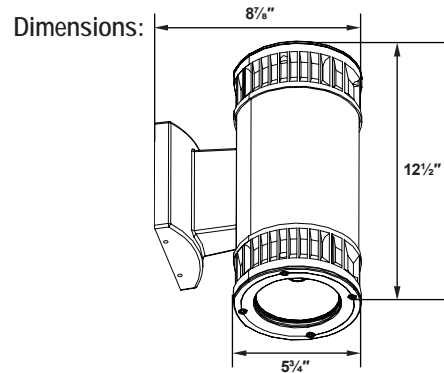

ORDERING FORMAT

Example: **CMPRDAC32X20U5KZSP**

CMPRD		C3	2X20	U	41K		
Model	Optics	LED	Wattage	Driver	CCT	Color	Options

Quick Ship option for Standard heights & colors only

CMPRD= LED Up/Down Wall Cylinder

A=70° Up/70° Down
 B=100° Up/100° Down
 C=70° Up/100° Down
 D=30° Up/30° Down
 E=30° Up/100° Down
 F=30° Up/70° Down
 G=100° Up/30° Down
 H=100° Up/70° Down
 I=70° Up/30° Down

C3=COB

2X20=40w

U=120-277V

41K=4100K

Z=Bronze
 B=Black
 C=Custom (Consult Factory)

SF=Single Fuse
 DF=Double Fuse
 SP=Surge Protection
 PC1=Photocell, 120VAC
 PC2=Photocell, 250-305VAC
 BU=Battery Backup, 90 Minutes





WALL MOUNT LIGHTING

Accessories & Replacement Parts:

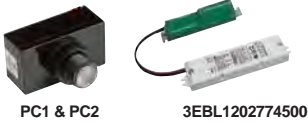

L70
25°C **89,000 Hours**

LED Up/Down Compass LED Wall Cylinder

Replacement Parts
(Order separately, Field installed)

PC1	120VAC Photocell
PC2	250-305VAC Photocell
3EBL1202774500	Battery Backup, Provides 90 Minutes of Backup Power

Photometric Data

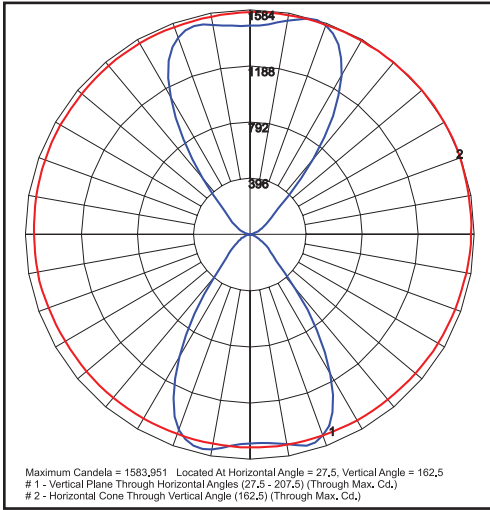

CMPRDAC32X20U41K
70° Up/70° Down Optic

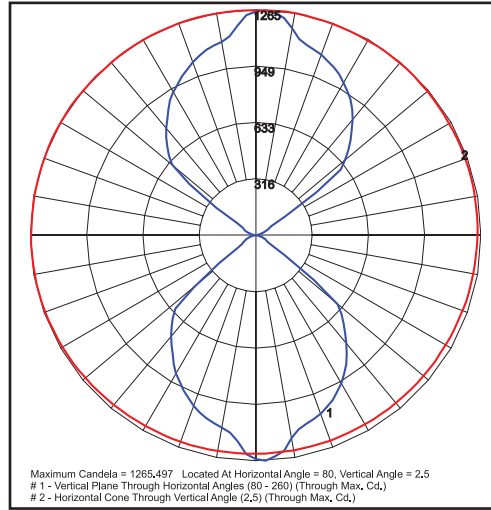

CMPRDBC32X20U41K
100° Up/100° Down Optic

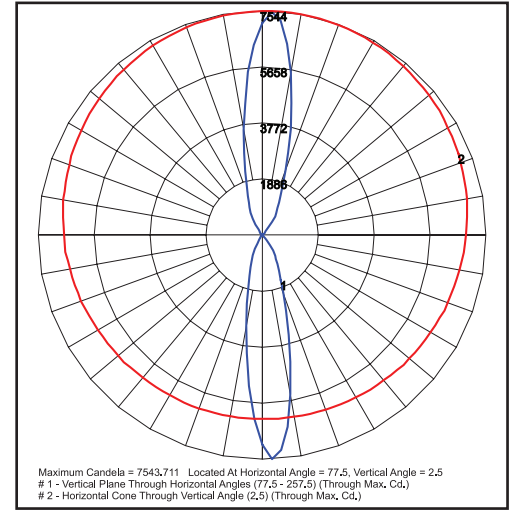

CMPRDDC32X20U41K
30° Up/30° Down Optic

Photometric Performance

LED Board Watts	Drive Current (mA)	Input Watts	Beam	4100 CCT 80 CRI				
				Lumens	LPW	B	U	G
LED COB 40w	525	40	A Medium	4,398	110	2	5	0
			B Wide	4,577	114	1	5	0
			D Narrow	4,344	109	2	5	0

Projected Lumen Maintenance

Data shown for 4100 CCT			Compare to MH			
TM-21-11	Input Watts	Initial	25,000 Hrs	50,000 Hrs	100,000 Hrs	Calculated L70 @ 25°C
L70 Lumen Maintenance @ 25°C / 77°F	40	1.00	0.92	0.83	0.66	89,000
TM-21-11	Input Watts	Initial	25,000 Hrs	50,000 Hrs	100,000 Hrs	Calculated L70 @ 50°C
L70 Lumen Maintenance @ 50°C / 122°F	40	1.00	0.90	0.81	0.62	78,000
TM-21-11	Input Watts	Initial	25,000 Hrs	50,000 Hrs	100,000 Hrs	Calculated L80 @ 40°C
L80 Lumen Maintenance @ 40°C / 104°F	40	1.00	0.93	0.86	0.72	72,000

NOTES:

1. Projected per IESNA TM-21-11. Data references the extrapolated performance projections for the 525mA base model in a 25°C ambient, based on 10,000 hours of LED testing per IESNA LM-80-08.
2. Compare to MH box indicates suggested Light Loss Factor (LLF) to be used when comparing to Metal Halide (MH) systems.

THREE PARTY PEER REVIEW SERVICES AGREEMENT

THE PARTIES:

The parties to this Agreement are the City of Portsmouth, a municipal corporation with a principal place of business at 680 Peverly Hill Road, Portsmouth, New Hampshire (CITY) and Iron Horse Properties, LLC, 105 Bartlett Street, Portsmouth, NH (DEVELOPER) for the Iron Horse Properties Developer Review for the subdivision on Bartlett Street (PROJECT) and Weston & Sampson Engineers, Inc. of 55 Walkers Brook Drive, Suite 100, Reading, MA (ENGINEER).

PURPOSE:

WHEREAS, the CITY and the DEVELOPER desire the City to retain the services of the ENGINEER to perform peer review services of the proposed Site Plan (SERVICES) regarding the PROJECT in order to facilitate the performance of site plan approval required by the City in a timely and efficient manner for the benefit of the City, and

WHEREAS, the DEVELOPER agrees to compensate the ENGINEER for providing the SERVICES to the CITY, on the terms and conditions of this Agreement;

NOW THEN, the parties to this Agreement agree as follows:

1. PERFORMANCE OF SERVICES:

A. As the agent and representative of the CITY, the ENGINEER shall perform all of the SERVICES described under the scope of work attached hereto as Exhibit A at the cost as shown thereon. All SERVICES shall be performed by the ENGINEER in a cost effective, timely and efficient manner, for the benefit of the CITY.

B. The CITY, the ENGINEER and the DEVELOPER have all reviewed and approved said scope of work attached to this Agreement as Exhibit A. No changes to said scope of work shall be made without the prior written consent of all parties to this Agreement.

2. PAYMENT FOR SERVICES; DISPUTES:

A. The ENGINEER shall provide original billings on a monthly basis for all Services provided hereunder, addressed to the Planning Director of the City of Portsmouth, with payment due within thirty (30) days of the delivery of each such bill to the Planning Director of the City of Portsmouth. At the same time, copies of each such bill shall also be provided to the Public Works Director of the City, and to the DEVELOPER. The DEVELOPER shall pay such bills within thirty (30) days of its receipt thereof. The DEVELOPER shall provide a copy of the relevant payment documentation to

the Planning Director of the City.

B. In the event the DEVELOPER raises any dispute or objection relating to any bill rendered by the ENGINEER under this Agreement, the DEVELOPER shall in the first instance so notify (NOTIFICATION) the Planning Director and the Public Works Director of the City, and in any event the parties shall make reasonable efforts to resolve such objection or dispute by informal means. Pending resolution of any dispute relating to any bill rendered by the ENGINEER, the DEVELOPER shall make payment of such disputed bill, in full, to the CITY rather than to the ENGINEER. If the informal means of resolving the dispute do not produce a resolution acceptable to all parties within thirty (30) days after such NOTIFICATION to the CITY of the dispute, then the Planning Director of the City shall make a final determination of such dispute within a total of 60 days after such NOTIFICATION, and the CITY shall disburse the amount of such disputed bill approved by the Planning Director to the ENGINEER, and shall return any unapproved amount thereof to the DEVELOPER.

3. TERMINATION AND FINAL DELIVERABLE:

Unless earlier terminated by the CITY, this Agreement shall continue in full force and effect among all parties until such time as the ENGINEER has completed the scope of work as identified in Exhibit A to the satisfaction of the CITY.

4. SITE PLAN REVIEW SECURITY:

All parties to this Agreement understand that the payment by the DEVELOPER to the ENGINEER under this Agreement is an element of the DEVELOPER's obligation to the CITY, and as such is secured by the security provided by the DEVELOPER for the Site Plan Review Agreement. Accordingly, the CITY will not release the portion of the Site Plan Review Agreement security related to the ENGINEER's Services until the ENGINEER has been paid for its performance under this Agreement.

CITY OF PORTSMOUTH

Dated: _____

By: _____
Department of Public Works

DEVELOPER

Date: 3/10/21

By: [Signature]
Glipper Traders, LLC owner Rep; Jeff Johnston

ENGINEER

[Signature]

Date: 2/11/2021

By: _____
Leah E. Stanton, PE, Vice President

EXHIBIT A

February 10, 2021

Raymond C. Pezzullo, P.E.
Assistant City Engineer
Portsmouth Department of Public Works
680 Pevery Hill Road
Portsmouth, NH 03801

Re: Engineering Services – 105 Bartlett Street Developer Review

Dear Mr. Pezzullo:

As requested, Weston & Sampson Engineers, Inc. proposes to provide engineering services for the evaluation of available pressures and flows to the Iron Horse Properties subdivision on Bartlett Street as described herein:

SCOPE OF SERVICES:

The following tasks shall be included in the project:

- Obtain information from the developer regarding the proposed development, including project location, proposed piping extension to the site, and information related to anticipated domestic and fire demands.
- Work with the City to perform a flow test on Bartlett Street with the Portsmouth Water Department to identify the static pressure, residual pressure, and available fire flow.
- Update the existing hydraulic model to incorporate the proposed development improvements and proposed development demands.
- Conduct hydraulic modeling analyses to determine flow and pressures available, as well as to evaluate the impact of the estimated demands on the existing distribution system. Identify improvements that may be needed in the existing system to provide adequate service to the development and to existing customers in accordance with NHDES regulations.
- Summarize the findings and recommendations of the study in a letter report. Provide a PDF copy of the letter report to the City of Portsmouth for review and comment.
- Incorporate the comments into a final letter report. One (1) copy of the final letter report shall be submitted in both PDF and paper formats.

The analysis will be based on plans or other information provided by the developer at the outset of the project; additional analysis required because of changes to those plans due to our findings is not consider a part of this scope of work.

SCHEDULE

Weston & Sampson agrees to provide services for the estimated duration of work as included under the Scope of Services, starting immediately upon receipt of a notice to proceed. The letter report will be submitted within 30 calendar days.

ENGINEERING FEE

For services performed, Iron Horse Properties, LLC agrees to pay Weston & Sampson the lump sum fee of \$5,600. Fees under this letter agreement shall be billed monthly as charges accrue for the services

performed as a percentage of the lump sum. Iron Horse Properties, LLC agrees to make payment to Weston & Sampson within thirty (30) days of the invoice date. Weston & Sampson's services will be provided as described herein and in accordance with the attached Weston & Sampson General Terms and Conditions dated May 2, 2017, which are a part of our agreement with you.

Agreement

This letter shall be Exhibit A to the Three-Party Peer Review Services Agreement provided by the City for the project. Weston & Sampson's standard terms and conditions are attached and shall apply except as specifically modified above or in the Three-Party Agreement. The agreement represents the entire agreement between the City of Portsmouth, Weston & Sampson, and Iron Horse Properties, LLC for this project.

We are pleased to submit this offering and look forward to working with you on this project. Please feel free to call me at 978-532-1900 x2386 if you have any questions or concerns.

Sincerely,

WESTON & SAMPSON ENGINEERS, INC.



Leah E. Stanton, PE
Vice President

2/11/2021

ACCEPTED FOR:

The City of Portsmouth, New Hampshire

Department of Public Works

Date

ACCEPTED FOR:

Iron Horse Properties, LLC

Owner Rep, Jeff Johnston

3/10/21

Date

Enclosures – Standard Terms and Conditions

cc:

P:\NH\Portsmouth, NH\Modeling On-Call\Bartlett St\New (2021) Iron Horse Properties Proposal\Proposal 2021.02.10.docx

WESTON & SAMPSON GENERAL TERMS AND CONDITIONS

1. It is understood that the Proposal attached hereto and dated February 10, 2021 is valid for a period of ninety (90) days. Upon the expiration of that period of time or the delay or suspension of the services, WESTON & SAMPSON reserves the right to review the proposed basis of payment and fees, to allow for changing costs as well as to adjust the period of performance to conform to work loads. References herein to WESTON & SAMPSON are understood to refer to WESTON & SAMPSON ENGINEERS, INC.
2. Invoices will be submitted periodically (customarily on a monthly basis), and terms are net cash, due and payable upon receipt of invoice. If the OWNER fails to make any payment due to WESTON & SAMPSON for services and expenses within thirty (30) days after receipt of WESTON & SAMPSON'S statement therefor, the amounts due WESTON & SAMPSON will be increased at the rate of 1.5% per month from said thirtieth day, and in addition, WESTON & SAMPSON may, after giving seven (7) days' written notice to the OWNER, suspend services under this Agreement. Unless payment is received by WESTON & SAMPSON within seven (7) days of the date of the notice, the suspension shall take effect without further notice. In the event of a suspension of services, WESTON & SAMPSON shall have no responsibility to the OWNER for delay or damage caused the OWNER because of such suspension of services.
3. WESTON & SAMPSON will serve as the professional representative of the OWNER as defined by the Proposal or under any Agreement and will provide advice, consultation and services to the OWNER in accordance with generally accepted professional practice consistent with that degree of skill and care ordinarily exercised by practicing design professionals performing similar services in the same locality, at the same site and under the same or similar circumstances and conditions. Therefore, estimates of cost, approvals, recommendations, opinions, and decisions by WESTON & SAMPSON are made on the basis of WESTON & SAMPSON'S experience, qualifications and professional judgment. Accordingly, WESTON & SAMPSON does not warrant or represent that bids or negotiated prices will not vary from the OWNER'S budget for the project, or from any estimate of the Cost of the Work evaluation prepared or agreed to by WESTON & SAMPSON. WESTON & SAMPSON makes no warranty or guarantee, express or implied, regarding the services or work to be provided under this Proposal or any related Agreement. Notwithstanding any other provision of these General Terms and Conditions, unless otherwise subject to a greater limitation, and to the fullest extent permitted by law, the total liability in the aggregate, of WESTON & SAMPSON and their officers, directors, employees, agents, and independent professional associates, and any of them, to OWNER and any one claiming by, through or under OWNER, for any and all injuries, claims, losses, expenses, or damages whatsoever arising out of in any way related to WESTON & SAMPSON'S services, the project, or this Agreement, from any cause or causes whatsoever, including but not limited to, the negligence, errors, omissions, strict liability, breach of contract, misrepresentation, or breach of warranty of WESTON & SAMPSON or WESTON & SAMPSON'S officers, directors, employees, agents or independent professional associates, or any of them, and any causes arising from or related to the COVID-19 pandemic, shall not exceed the greater of \$50,000 or the total compensation received by WESTON & SAMPSON hereunder and OWNER hereby releases WESTON & SAMPSON from any liability above such amount. WESTON & SAMPSON shall have no upfront duty to defend the OWNER but shall reimburse defense costs of the OWNER to the same extent of its indemnity obligation herein.
4. Where the Services include subsurface exploration, the OWNER acknowledges that the use of exploration equipment may alter or damage the terrain, vegetation, structures, improvements, or the other property at the Site and accepts the risk. Provided WESTON & SAMPSON uses reasonable care, WESTON & SAMPSON shall not be liable for such alteration or damage or for damage to or interference with any subterranean structure, pipe, tank, cable, or other element or condition whose nature and location are not called to WESTON & SAMPSON'S attention in writing before exploration begins.
5. WESTON & SAMPSON and its consultants shall have no responsibility for the discovery, presence, handling, removal or disposal of, or exposure of persons to, hazardous waste or viruses, including COVID-19, in any form at the project site. Accordingly, the OWNER agrees to assert no claims against WESTON & SAMPSON, its principals, agents, employees and consultants, if

such claim is based, in whole or in part, upon the negligence, breach of contract, breach of warranty, indemnity or other alleged obligation of WESTON & SAMPSON or its consultants, and arises out of or in connection with the detection, assessment, abatement, identification or remediation of hazardous materials, pollutants or asbestos at, in, under or in the vicinity of the project site identified in the Proposal. OWNER shall defend, indemnify and hold harmless WESTON & SAMPSON, its principals, agents, employees, and consultants and each of them, harmless from and against any and all costs, liability, claims, demands, damages or expenses, including reasonable attorneys' fees, with respect to any such claim or claims described in the preceding sentence, whether asserted by OWNER or any other person or entity. WESTON & SAMPSON shall not be liable for any damages or injuries of any nature whatsoever, due to any delay or suspension in the performance of its services caused by or arising out of the discovery of hazardous substances or pollutants at the project site or exposure of any parties to the COVID-19 virus.

6. WESTON & SAMPSON agrees to purchase at its own expense, Worker's Compensation insurance, Comprehensive General Liability insurance, and Engineer's Professional Liability insurance and will, upon request, furnish insurance certificates to OWNER reflecting WESTON & SAMPSON's standard coverage. WESTON & SAMPSON agrees to purchase whatever additional insurance is requested by OWNER (presuming such insurance is available, from carriers acceptable to WESTON & SAMPSON) provided OWNER reimburses the premiums for additional insurance.
7. As a part of this Agreement, OWNER without cost to WESTON & SAMPSON agrees to do the following in a timely manner so as not to delay the services of WESTON & SAMPSON:
 - a. Designate in writing a person to act as OWNER'S representative with respect to work to be performed under this Agreement, such person to have complete authority to transmit instructions, receive information, interpret and define OWNER'S policies and decisions with respect to materials, equipment elements and systems pertinent to the work covered by the Agreement.
 - b. Through its officials and other employees who have knowledge of pertinent conditions, confer

with WESTON & SAMPSON regarding both general and special considerations relating to the Project.

- c. Assist WESTON & SAMPSON by placing at the disposal of WESTON & SAMPSON, all available information pertinent to the Project including previous reports and other data relative to design or construction of Project.
- d. Furnish or cause to be furnished to WESTON & SAMPSON all documents and information known to OWNER that relate to the identity, location, quantity, nature or characteristics of any hazardous waste at, on or under the site. In addition, OWNER will furnish or cause to be furnished such other reports, data, studies, plans, specifications, documents and other information on surface and subsurface site conditions required by WESTON & SAMPSON for proper performance of its services.
- e. WESTON & SAMPSON shall be entitled to rely, without liability, on the accuracy and completeness of information and documents provided by the OWNER, OWNER'S CONSULTANTS and CONTRACTORS and information from public records, without the need for independent verification.
- f. Pay for all application and permit fees associated with approvals and permits for all governmental authorities having jurisdiction over the Project and such approvals and consents from others as may be necessary for completion of the Project.
- g. Arrange for and make all provisions for WESTON & SAMPSON and its agents to enter upon public and private lands as required for WESTON & SAMPSON to perform its work under this Agreement.
- h. Furnish WESTON & SAMPSON with all necessary topographic, property, boundary and right-of-way maps.
- i. Cooperate with and assist WESTON & SAMPSON in all additional work that is mutually agreed upon.
- j. Pay WESTON & SAMPSON for work performed in accordance with terms specified herein.

8. The obligation to provide further services under this Agreement may be terminated by either party upon thirty days' written notice in the event of substantial failure by the other party to perform in accordance with the terms hereof through no fault of the terminating party. If the Project is suspended or abandoned in whole or in part for more than three (3) months, WESTON & SAMPSON shall be compensated for all services performed prior to receipt of written notice from OWNER of such suspension or abandonment, together with the other direct costs then due. If the Project is resumed after being suspended for more than three (3) months, WESTON & SAMPSON'S compensation shall be equitably adjusted. In the event of termination by either party, WESTON & SAMPSON shall be compensated for all services performed prior to receipt of written termination, together with other direct costs then due, including WESTON & SAMPSON's independent consultants, and for the services necessary to affect termination.
9. The OWNER and WESTON & SAMPSON waive all rights against each other and against the contractors, consultants, agents and employees of the other for damages, but only to the extent covered by any property or other insurance in effect whether during or after the project. The OWNER and WESTON & SAMPSON shall each require similar waivers from their contractors, consultants and agents.
10. All Drawings, diagrams, plans, specifications, calculations, reports, processes, computer processes and software, operational and design data, and all other documents and information produced in connection with the project as instruments of service, regardless of form, shall be confidential and the property of WESTON & SAMPSON, and shall remain the sole and exclusive property of WESTON & SAMPSON whether the project for which they are made is executed or not. The OWNER shall not have or acquire any title to or ownership rights in any of the documents or information prepared by WESTON & SAMPSON. OWNER may make and retain copies for information and reference in connection with the use and occupancy of the Project by the OWNER and others; however, such documents are not intended or represented to be suitable for reuse by OWNER or others on extensions of the Project or on any other Projects. Any reuse without written verification or adaptation by WESTON & SAMPSON for the specific purpose intended will be at OWNER'S sole risk and without liability or legal exposure to WESTON & SAMPSON or to WESTON & SAMPSON's independent consultants, and OWNER shall indemnify and hold harmless WESTON & SAMPSON and WESTON & SAMPSON's independent consultants from all claims, damages, losses, and expenses, including attorneys' fees arising out of or resulting therefrom. Any such verification or adaptation will entitle WESTON & SAMPSON to further compensation at rates to be agreed upon by OWNER and WESTON & SAMPSON.
11. The substantive laws of the Commonwealth of Massachusetts shall govern any disputes between WESTON & SAMPSON and the OWNER arising out of the interpretation and performance of this Agreement.
12. WESTON & SAMPSON and the OWNER agree that any disputes arising under this Agreement and the performance thereof shall be subject to nonbinding mediation as a prerequisite to further legal proceedings. The parties may engage in remote mediation if in-person mediation is not possible or practicable due to the COVID-19 pandemic, or if mutually agreed upon between the parties.
13. WESTON & SAMPSON shall not be required to sign any documents, no matter by who requested, that would result in WESTON & SAMPSON having to certify, guaranty, or warrant the existence of conditions that would require knowledge, services or responsibilities beyond the scope of this Agreement.
14. Nothing contained in this Agreement shall create a contractual relationship with, or a cause of action in favor of, a third party against either the OWNER or WESTON & SAMPSON. WESTON & SAMPSON'S services hereunder are being performed solely for the benefit of the OWNER, and no other entity shall have any claim against WESTON & SAMPSON because of this Agreement or WESTON & SAMPSON'S performance of services hereunder.
15. Notwithstanding anything to the contrary contained herein, OWNER and ENGINEER agree that their sole and exclusive claim, demand, suit, judgment or remedy against each other shall be asserted against each other's corporate entity and not against each other's shareholders, A/E's, directors, officers or employees.

16. To the extent they are inconsistent or contradictory, express terms of this Proposal take precedence over these General Terms and Condition. It is understood and agreed that the services or work performed under this Proposal or any Agreement are not subject to any provision of any Uniform Commercial Code. Any terms and conditions set forth in OWNER'S purchase order, requisition, or other notice or authorization to proceed are inapplicable to the services under this Proposal or any related Agreement, except when specifically provided for in full on the face of such purchase order, requisition, or notice or authorization and specifically accepted in writing by WESTON & SAMPSON. WESTON & SAMPSON'S acknowledgement of receipt of any purchase order, requisition, notice or authorization, or WESTON & SAMPSON'S performance of work subsequent to receipt thereof, does not constitute acceptance of any terms or conditions other than those set forth herein.

17. If any provision of this Agreement shall be finally determined to be invalid or unenforceable in whole or in part, the remaining provisions hereof shall remain in full force and effect, and be binding upon the parties hereto. The parties agree to reform this Agreement to replace any such invalid or unenforceable provision with a valid and enforceable provision that comes as close as possible to the intention of the stricken provision.

19. If delays or failures of performance of WESTON & SAMPSON are caused by occurrences beyond the reasonable control of WESTON & SAMPSON, WESTON & SAMPSON shall not be in default of this AGREEMENT. Said occurrences shall include Acts of God or the public enemy; expropriation or confiscation; compliance with any quarantine or other order of any governmental authority; pandemic; epidemic; public health crisis; labor or materials shortage; changes in law; act of war, rebellion, terrorism or sabotage or damage resulting therefrom; fires, floods, explosions, accidents, riots, strikes or other concerted acts of workmen, whether direct or indirect; delays in permitting; OWNER's failure to provide data in OWNER's possession or provide necessary comments in connection with any required reports prepared by WESTON & SAMPSON, or any other causes which are beyond the reasonable control of WESTON & SAMPSON. WESTON & SAMPSON's scheduled completion date shall be adjusted to account for any force majeure delay and WESTON & SAMPSON shall be compensated for all costs incurred in connection with or arising from a force

majeure event or in the exercise of reasonable diligence to avoid or mitigate a force majeure event.

Approved by:

Jeff Johnston

 OWNER Name



 Signature

3/16/21

 Date

Owner Rep

 Printed Name and Title

P:\NH\Portsmouth, NH\Modeling On-Call\Bartlett St\New (2021) Iron Horse Properties Proposal\General Terms & Conditions.docx