



HALEY WARD®

APPLICATION FOR SITE PLAN REVIEW AND SUBDIVISION APPROVAL

**TO THE CITY OF PORTSMOUTH
FOR 20 CENTRAL AVENUE**

Map 209, Lot 30 | Portsmouth, NH

APPLICANT:

Copley Properties, LLC

94 Portsmouth Avenue, Stratham, NH 03885

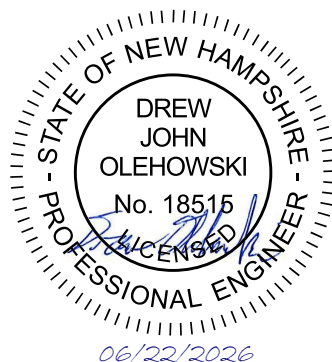

June 22, 2026
JN: 5010658.001

APPLICATION PREPARED BY:

Haley Ward, Inc.

200 Griffin Road, Unit 14 | Portsmouth, NH 03801



June 22, 2026

Peter Stith, TAC Committee Chair
City of Portsmouth
1 Junkins Avenue
Portsmouth, NH 03801

**RE: Request for TAC Review
20 Central Avenue
Site Plan Review**

Dear Mr. Stith and Technical Advisory Committee (TAC) Members,

On behalf of Copley Properties (Copley) we are pleased to submit the attached plan set for **Site Plan and Subdivision Review** for the above-mentioned project and request that we be placed on the agenda for your **July 7, 2026**, meeting. The project is the demolition of the existing dwelling, subdivision of the lot, and proposed new construction of three (3) single-family homes with the associated and required site improvements.

Within this application we have provided a drawing set that includes depictions of both the parcel's existing and proposed conditions. The proposed conditions include the three dwellings and associated driveways, utilities, grading/stormwater, landscaping, and typical notes/details. This application includes submission items as required for Site Plan and Subdivision review per the City's Review Checklists.

PROJECT OVERVIEW

The project consists of subdividing the existing residential lot located at 20 Central Avenue into three lots for residential development. The existing site has a total area of 28,972 square feet. The existing home, the garage/shed, and westerly driveway will be removed, and the lot will be subdivided with three single family homes. We are requesting the Technical Advisory Committee (TAC) review the project as a part of the approval process, prior to a completed Subdivision application at the site, and we look forward to an in-person presentation and the TAC Committee review of this submission.

Once subdivided, the project includes the construction of 3 single-family dwellings with associated walkways and driveways on each lot. Preliminary building footprints, site layouts, drainage and utilities are shown in the attached submittal to show compliance with the ordinance. Final layouts and design will be prepared and submitted with the building permits. The development of the site will comply with the applicable design, safety, and operational standards, including building code compliance. We believe that the additional residential development will complement the surrounding neighborhood.

SITE ZONING

The project is within the City of Portsmouth General Residential A (GRA) District which allows for residential development. The proposed project is consistent with the



surrounding neighborhood which is predominantly single family residential. As proposed with the subdivided lot, the project meets all zoning requirements.

PARKING

Each residence will have a two-car garage in addition to one surface space for a total of three spaces per unit. The overall project will include nine total parking spaces.

VEHICULAR AND PEDESTRIAN CIRCULATION

The proposed developments will be accessed by a 20-foot-wide paved driveway with a turnaround for each property. Access to the southerly and easterly properties will be from Beechwood Street; the northerly property access will be from Central Avenue.

TRAFFIC

A trip generation letter has been prepared for the AM and PM peak hour trips based on the Institute of Transportation Engineer's (ITE) publication, Trip Generation, 12th Edition and is included in this submission. The analysis demonstrates no significant change from existing traffic volumes or patterns.

NOISE

The property is located in a Highway Noise Overlay District. A Conditional Use Permit has been prepared to meet Noise Analysis requirements. The Noise Analysis was prepared by Reuters Associates and demonstrates the proposed development will comply with Ordinance sound level limits for indoor and outdoor activity. This permit will be submitted for Planning Board review following TAC review.

SCREENING AND LANDSCAPING

The proposed landscaping provides a blend of street trees and shrubs to enhance the property while providing screening around the perimeter. A proposed landscaping plan, prepared by a registered landscape architect, has been provided.

WATER AND SEWAGE SYSTEMS

The development will be served by municipal water and sewer located within Central Avenue and Beechwood Street. New tie-ins will be extended into the site from the existing 8" PVC sewer in Beechwood Street to collect the laterals for each dwelling unit. Locations of the tie-ins will be confirmed with the Portsmouth Department of Public Works (DPW). All onsite sewers will be 6" PVC SDR 35 gasketed pipe. A 1" domestic water line will be extended into the property to serve each dwelling.

STORMWATER MANAGEMENT

The proposed stormwater will decrease runoff flow while maintaining existing flow patterns and continue to discharge to the southeast into the existing municipal system. Refer to the Stormwater Management and Erosion Control Plan includes as part of this submittal for additional details related to the stormwater design.



SITE LIGHTING

Site lighting will be wall mounted and designed at minimum levels to provide a welcoming and safe pedestrian experience and not create excess lighting within the neighborhood. No pole mounted lighting is proposed as part of this project.

SITE UTILITIES

Each building will be served by underground electric/communications services. Included in the submission is a “will serve” letter for the project from Unifil. Included in the submission is a copy of the Eversource work order.

SOLID WASTE

Solid waste will be collected through Portsmouth curb side pickup.

SUBMISSION

The submission includes Plans, the Subdivision Application Checklist, a Tax Map, an Aerial Map and a Drainage Management and Erosion Control Plan.

The following drawings are included in our submission:

- C000 – Cover Sheet
- C001 – General Notes, Legend & Abbreviations
- Subdivision Plan – This plan shows the proposed subdivision and easements.
- V101 – Conditions Plan – This plan shows the existing conditions at the site.
- C101 – Demolition Plan – This plan shows the proposed demolition and construction preparations.
- C102 – Site Layout & Utility Plan – This plan shows proposed site layout and utilities.
- C103 – Grading & Drainage Plan – This plan shows the proposed stormwater improvements.
- C501 & C502 – Construction Details
- C701 & C702 – Pre- & Post-Development Hydrology Plans – These plans show the existing and proposed drainage areas and flow paths.

We look forward to Technical Advisory Committee review of this submission and look forward to an in-person presentation at your meeting.

Sincerely,
Haley Ward, Inc.

Drew Olehowski, PE
Project Manager



City of Portsmouth, New Hampshire

Site Plan Application Checklist

This site plan application checklist is a tool designed to assist the applicant in the planning process and for preparing the application for Planning Board review. The checklist is required to be completed and uploaded to the Site Plan application in the City's online permitting system. A pre-application conference with a member of the planning department is strongly encouraged as additional project information may be required depending on the size and scope. The applicant is cautioned that this checklist is only a guide and is not intended to be a complete list of all site plan review requirements. Please refer to the Site Plan review regulations for full details.

Applicant Responsibilities (Section 2.5.2): Applicable fees are due upon application submittal along with required attachments. The application shall be complete as submitted and provide adequate information for evaluation of the proposed site development. Waiver requests must be submitted in writing with appropriate justification.

Name of Applicant: Copley Properties Date Submitted: June 22, 2026

Application # (in City's online permitting): _____

Site Address: 20 Central Avenue Map: 209 Lot: 30

Application Requirements			
<input checked="" type="checkbox"/>	Required Items for Submittal	Item Location (e.g. Page or Plan Sheet/Note #)	Waiver Requested
<input checked="" type="checkbox"/>	Complete application form submitted via the City's web-based permitting program (2.5.2.1(2.5.2.3A))	Online	N/A
<input checked="" type="checkbox"/>	All application documents, plans, supporting documentation and other materials uploaded to the application form in viewpoint in digital Portable Document Format (PDF). One hard copy of all plans and materials shall be submitted to the Planning Department by the published deadline. (2.5.2.8)	Online & Delivered	N/A

Site Plan Review Application Required Information			
<input checked="" type="checkbox"/>	Required Items for Submittal	Item Location (e.g. Page/line or Plan Sheet/Note #)	Waiver Requested
<input checked="" type="checkbox"/>	Statement that lists and describes "green" building components and systems. (2.5.3.1B)	Green Building Narrative Included	
<input checked="" type="checkbox"/>	Existing and proposed gross floor area and dimensions of all buildings and statement of uses and floor area for each floor. (2.5.3.1C)	Architectural Plans	N/A
<input checked="" type="checkbox"/>	Tax map and lot number, and current zoning of all parcels under Site Plan Review. (2.5.3.1D)	Site Plans	N/A

Site Plan Review Application Required Information

<input checked="" type="checkbox"/>	Required Items for Submittal	Item Location (e.g. Page/line or Plan Sheet/Note #)	Waiver Requested
<input checked="" type="checkbox"/>	Owner's name, address, telephone number, and signature. Name, address, and telephone number of applicant if different from owner. (2.5.3.1E)	Cover Sheet C000	N/A
<input checked="" type="checkbox"/>	Names and addresses (including Tax Map and Lot number and zoning districts) of all direct abutting property owners (including properties located across abutting streets) and holders of existing conservation, preservation or agricultural preservation restrictions affecting the subject property. (2.5.3.1F)	Existing Conditions Plan V101	N/A
<input checked="" type="checkbox"/>	Names, addresses and telephone numbers of all professionals involved in the site plan design. (2.5.3.1G)	Cover Sheet C000	N/A
<input checked="" type="checkbox"/>	List of reference plans. (2.5.3.1H)	Cover Sheet C000	N/A
<input checked="" type="checkbox"/>	List of names and contact information of all public or private utilities servicing the site. (2.5.3.1I)	Cover Sheet C000	N/A

Site Plan Specifications

<input checked="" type="checkbox"/>	Required Items for Submittal	Item Location (e.g. Page/line or Plan Sheet/Note #)	Waiver Requested
<input checked="" type="checkbox"/>	Full size plans shall not be larger than 22 inches by 34 inches with match lines as required, unless approved by the Planning Director.. (2.5.4.1A)	Required on all plan sheets	N/A
<input checked="" type="checkbox"/>	Scale: Not less than 1 inch = 60 feet and a graphic bar scale shall be included on all plans. (2.5.4.1B)	Required on all plan sheets	N/A
<input checked="" type="checkbox"/>	GIS data should be referenced to the coordinate system New Hampshire State Plane, NAD83 (1996), with units in feet. (2.5.4.1C)	Complies	N/A
<input checked="" type="checkbox"/>	Plans shall be drawn to scale and stamped by a NH licensed civil engineer. (2.5.4.1D)	Required on all plan sheets	N/A
<input type="checkbox"/>	Wetlands shall be delineated by a NH certified wetlands scientist and so stamped. (2.5.4.1E)	No Wetlands Onsite	N/A
<input checked="" type="checkbox"/>	Title (name of development project), north point, scale, legend. (2.5.4.2A)	All Sheets	N/A
<input checked="" type="checkbox"/>	Date plans first submitted, date and explanation of revisions. (2.5.4.2B)	All Sheets	N/A
<input checked="" type="checkbox"/>	Individual plan sheet title that clearly describes the information that is displayed. (2.5.4.2C)	Required on all plan sheets	N/A
<input checked="" type="checkbox"/>	Source and date of data displayed on the plan. (2.5.4.2D)	Existing Conditions Plan V101	N/A

Site Plan Specifications – Required Exhibits and Data

<input checked="" type="checkbox"/>	Required Items for Submittal	Item Location (e.g. Page/line or Plan Sheet/Note #)	Waiver Requested
<input checked="" type="checkbox"/>	<p>1. Existing Conditions: (2.5.4.3A)</p> <ul style="list-style-type: none"> • Surveyed plan of site showing existing natural and built features; • Existing building footprints and gross floor area; • Existing parking areas and number of parking spaces provided; • Zoning district boundaries; • Existing, required, and proposed dimensional zoning requirements including building and open space coverage, yards and/or setbacks, and dwelling units per acre; • Existing impervious and disturbed areas; • Limits and type of existing vegetation; • Wetland delineation, wetland function and value assessment (including vernal pools); • SFHA, 100-year flood elevation line and BFE data, as required. 	<p>Existing Conditions Plan V101</p>	
<input checked="" type="checkbox"/>	<p>2. Buildings and Structures: (2.5.4.3B)</p> <ul style="list-style-type: none"> • Plan view: Use, size, dimensions, footings, overhangs, 1st fl. elevation; • Elevations: Height, massing, placement, materials, lighting, façade treatments; • Total Floor Area; • Number of Usable Floors; • Gross floor area by floor and use. 	<p>Architectural Plans</p>	
<input checked="" type="checkbox"/>	<p>3. Access and Circulation: (2.5.4.3C)</p> <ul style="list-style-type: none"> • Location/width of access ways within site; • Location of curbing, right of ways, edge of pavement and sidewalks; • Location, type, size and design of traffic signing (pavement markings); • Names/layout of existing abutting streets; • Driveway curb cuts for abutting prop. and public roads; • If subdivision; Names of all roads, right of way lines and easements noted; • AASHTO truck turning templates, description of minimum vehicle allowed being a WB-50 (unless otherwise approved by TAC). 	<p>Site Layout Plan C101</p>	
<input checked="" type="checkbox"/>	<p>4. Parking and Loading: (2.5.4.3D)</p> <ul style="list-style-type: none"> • Location of off street parking/loading areas, landscaped areas/buffers; • Parking Calculations (# required and the # provided). 	<p>Site Layout Plan C101</p>	
<input checked="" type="checkbox"/>	<p>5. Water Infrastructure: (2.5.4.3E)</p> <ul style="list-style-type: none"> • Size, type and location of water mains, shut-offs, hydrants & Engineering data; • Location of wells and monitoring wells (include protective radii). 	<p>Utility Plan C102</p>	
<input checked="" type="checkbox"/>	<p>6. Sewer Infrastructure: (2.5.4.3F)</p> <ul style="list-style-type: none"> • Size, type and location of sanitary sewage facilities & Engineering data, including any onsite temporary facilities during construction period. 	<p>Utility Plan C102</p>	

<input checked="" type="checkbox"/>	7. Utilities: (2.5.4.3G) <ul style="list-style-type: none"> The size, type and location of all above & below ground utilities; Size type and location of generator pads, transformers and other fixtures. 	Utility Plan C102	
<input checked="" type="checkbox"/>	8. Solid Waste Facilities: (2.5.4.3H) <ul style="list-style-type: none"> The size, type and location of solid waste facilities. 	City Curbside Pickup Note on C102	
<input checked="" type="checkbox"/>	9. Storm water Management: (2.5.4.3I) <ul style="list-style-type: none"> The location, elevation and layout of all storm-water drainage. The location of onsite snow storage areas and/or proposed off-site snow removal provisions. Location and containment measures for any salt storage facilities Location of proposed temporary and permanent material storage locations and distance from wetlands, water bodies, and stormwater structures. 	Grading & Drainage Plan C103	
<input checked="" type="checkbox"/>	10. Outdoor Lighting: (2.5.4.3J) <ul style="list-style-type: none"> Type and placement of all lighting (exterior of building, parking lot and any other areas of the site) and photometric plan. 	Wall Mounted Residential Lighting Only. Note On C102	
<input checked="" type="checkbox"/>	11. Indicate where dark sky friendly lighting measures have been implemented. (10.1)	Note On C102	
<input checked="" type="checkbox"/>	12. Landscaping: (2.5.4.3K) <ul style="list-style-type: none"> Identify all undisturbed area, existing vegetation and that which is to be retained; Location of any irrigation system and water source. 	Landscape Plan L-101	
<input checked="" type="checkbox"/>	13. Contours and Elevation: (2.5.4.3L) <ul style="list-style-type: none"> Existing/Proposed contours (2 foot minimum) and finished grade elevations. 	Grading & Drainage Plan C103	
<input checked="" type="checkbox"/>	14. Open Space: (2.5.4.3M) <ul style="list-style-type: none"> Type, extent and location of all existing/proposed open space. 	Site Layout Plan C101	
<input checked="" type="checkbox"/>	15. All easements, deed restrictions and non-public rights of ways. (2.5.4.3N)	Existing Conditions Plan V101	
<input type="checkbox"/>	16. Character/Civic District (All following information shall be included): (2.5.4.3P) <ul style="list-style-type: none"> Applicable Building Height (10.5A21.20 & 10.5A43.30); Applicable Special Requirements (10.5A21.30); Proposed building form/type (10.5A43); Proposed community space (10.5A46). 	N/A	
<input type="checkbox"/>	17. Special Flood Hazard Areas (2.5.4.3Q) <ul style="list-style-type: none"> The proposed development is consistent with the need to minimize flood damage; All public utilities and facilities are located and construction to minimize or eliminate flood damage; Adequate drainage is provided so as to reduce exposure to flood hazards. 	N/A	

Other Required Information			
<input checked="" type="checkbox"/>	Required Items for Submittal	Item Location (e.g. Page/line or Plan Sheet/Note #)	Waiver Requested
<input checked="" type="checkbox"/>	Traffic Impact Study or Trip Generation Report, as required. (3.2.1-2)	Trip Generation Letter	
<input checked="" type="checkbox"/>	Indicate where Low Impact Development Design practices have been incorporated. (7.1)	Drainage Analysis	
<input type="checkbox"/>	Indicate whether the proposed development is located in a wellhead protection or aquifer protection area. Such determination shall be approved by the Director of the Dept. of Public Works. (7.3.1)	N/A	
<input checked="" type="checkbox"/>	Stormwater Management and Erosion Control Plan. (7.4)	Grading & Drainage Plan C102	
<input checked="" type="checkbox"/>	Inspection and Maintenance Plan (7.6.5)	Drainage Analysis	

Final Site Plan Approval Required Information			
<input checked="" type="checkbox"/>	Required Items for Submittal	Item Location (e.g. Page/line or Plan Sheet/Note #)	Waiver Requested
<input checked="" type="checkbox"/>	All local approvals, permits, easements and licenses required, including but not limited to: <ul style="list-style-type: none"> • Waivers; • Driveway permits; • Special exceptions; • Variances granted; • Easements; • Licenses. (2.5.3.2A)	Cover Sheet C000	
<input checked="" type="checkbox"/>	Exhibits, data, reports or studies that may have been required as part of the approval process, including but not limited to: <ul style="list-style-type: none"> • Calculations relating to stormwater runoff; • Information on composition and quantity of water demand and wastewater generated; • Information on air, water or land pollutants to be discharged, including standards, quantity, treatment and/or controls; • Estimates of traffic generation and counts pre- and post-construction; • Estimates of noise generation; • A Stormwater Management and Erosion Control Plan; • Endangered species and archaeological / historical studies; • Wetland and water body (coastal and inland) delineations; • Environmental impact studies. (2.5.3.2B)	Included In Online Submittal	
<input checked="" type="checkbox"/>	A document from each of the required private utility service providers indicating approval of the proposed site plan and indicating an ability to provide all required private utilities to the site. (2.5.3.2D)	Included In Online Submittal	

Final Site Plan Approval Required Information

<input checked="" type="checkbox"/>	Required Items for Submittal	Item Location (e.g. Page/line or Plan Sheet/Note #)	Waiver Requested
<input checked="" type="checkbox"/>	A list of any required state and federal permit applications required for the project and the status of same. (2.5.3.2E)	Cover Sheet C000	
<input checked="" type="checkbox"/>	A note shall be provided on the Site Plan stating: "All conditions on this Plan shall remain in effect in perpetuity pursuant to the requirements of the Site Plan Review Regulations." (2.5.4.2E)	Site Layout Plan C101	N/A
<input type="checkbox"/>	For site plans that involve land designated as "Special Flood Hazard Areas" (SFHA) by the National Flood Insurance Program (NFIP) confirmation that all necessary permits have been received from those governmental agencies from which approval is required by Federal or State law, including Section 404 of the Federal Water Pollution Control Act Amendments of 1972, 33 U.S.C. 1334. (2.5.4.2F)	N/A	
<input type="checkbox"/>	Plan sheets submitted for recording shall include the following notes: a. "This Site Plan shall be recorded in the Rockingham County Registry of Deeds." b. "All improvements shown on this Site Plan shall be constructed and maintained in accordance with the Plan by the property owner and all future property owners. No changes shall be made to this Site Plan without the express approval of the Portsmouth Planning Director." (2.13.3)	Site Layout Plan C101	N/A

Applicant's Signature:  Date: June 22, 2026
Applicants Agent



City of Portsmouth, New Hampshire

Subdivision Application Checklist

This subdivision application checklist is a tool designed to assist the applicant in the planning process and for preparing the application for Planning Board review. A pre-application conference with a member of the planning department is strongly encouraged as additional project information may be required depending on the size and scope. The applicant is cautioned that this checklist is only a guide and is not intended to be a complete list of all subdivision review requirements. Please refer to the Subdivision review regulations for full details.

Applicant Responsibilities (Section III.C): Applicable fees are due upon application submittal along with required number of copies of the Preliminary or final plat and supporting documents and studies. Please consult with Planning staff for submittal requirements.

Owner: _____ Date Submitted: _____

Applicant: _____

Phone Number: _____ E-mail: _____

Site Address 1: _____ Map: _____ Lot: _____

Site Address 2: _____ Map: _____ Lot: _____

Application Requirements			
<input checked="" type="checkbox"/>	Required Items for Submittal	Item Location (e.g. Page or Plan Sheet/Note #)	Waiver Requested
<input type="checkbox"/>	Completed Application form. (III.C.2-3)		N/A
<input type="checkbox"/>	All application documents, plans, supporting documentation and other materials provided in digital Portable Document Format (PDF) on compact disc, DVD or flash drive. (III.C.4)		N/A

Requirements for Preliminary/Final Plat				
<input checked="" type="checkbox"/>	Required Items for Submittal	Item Location (e.g. Page/line or Plan Sheet/Note #)	Required for Preliminary / Final Plat	Waiver Requested
<input type="checkbox"/>	Name and address of record owner, any option holders, descriptive name of subdivision, engineer and/or surveyor or name of person who prepared the plat. (Section IV.1/V.1)		<input checked="" type="checkbox"/> Preliminary Plat <input checked="" type="checkbox"/> Final Plat	N/A

Requirements for Preliminary/Final Plat				
<input checked="" type="checkbox"/>	Required Items for Submittal	Item Location (e.g. Page/line or Plan Sheet/Note #)	Required for Preliminary / Final Plat	Waiver Requested
<input type="checkbox"/>	<p>Preliminary Plat Names and addresses of all adjoining property owners. (Section IV.2)</p> <p>Final Plat Names and addresses of all abutting property owners, locations of buildings within one hundred (100) feet of the parcel, and any new house numbers within the subdivision. (Section V.2)</p>		<input checked="" type="checkbox"/> Preliminary Plat <input checked="" type="checkbox"/> Final Plat	N/A
<input type="checkbox"/>	North point, date, and bar scale. (Section IV.3/V3)	Required on all Plan Sheets	<input checked="" type="checkbox"/> Preliminary Plat <input checked="" type="checkbox"/> Final Plat	N/A
<input type="checkbox"/>	Zoning classification and minimum yard dimensions required. (Section IV.4/V.4)		<input checked="" type="checkbox"/> Preliminary Plat <input checked="" type="checkbox"/> Final Plat	N/A
<input type="checkbox"/>	<p>Preliminary Plat Scale (not to be smaller than one hundred (100) feet = 1 inch) and location map (at a scale of 1" = 1000'). (Section IV.5)</p> <p>Final Plat Scale (not to be smaller than 1"=100'), Location map (at a scale of 1"=1,000') showing the property being subdivided and its relation to the surrounding area within a radius of 2,000 feet. Said location map shall delineate all streets and other major physical features that my either affect or be affected by the proposed development. (Section V.5)</p>		<input checked="" type="checkbox"/> Preliminary Plat <input checked="" type="checkbox"/> Final Plat	N/A
<input type="checkbox"/>	Location and approximate dimensions of all existing and proposed property lines including the entire area proposed to be subdivided, the areas of proposed lots, and any adjacent parcels in the same ownership. (Section IV.6)		<input checked="" type="checkbox"/> Preliminary Plat <input checked="" type="checkbox"/> Final Plat	
<input type="checkbox"/>	Dimensions and areas of all lots and any and all property to be dedicated or reserved for schools, parks, playgrounds, or other public purpose. Dimensions shall include radii and length of all arcs and calculated bearing for all straight lines. (Section V.6/ IV.7)		<input checked="" type="checkbox"/> Preliminary Plat <input checked="" type="checkbox"/> Final Plat	N/A
<input type="checkbox"/>	Location, names, and present widths of all adjacent streets, with a designation as to whether public or private and approximate location of existing utilities to be used. Curbs and sidewalks shall be shown. (Section IV.8/V.7)		<input checked="" type="checkbox"/> Preliminary Plat <input checked="" type="checkbox"/> Final Plat	

Requirements for Preliminary/Final Plat				
<input checked="" type="checkbox"/>	Required Items for Submittal	Item Location (e.g. Page/line or Plan Sheet/Note #)	Required for Preliminary / Final Plat	Waiver Requested
<input type="checkbox"/>	Location of significant physical features, including bodies of water, watercourses, wetlands, railroads, important vegetation, stone walls and soils types that may influence the design of the subdivision. (Section IV.9/V.8)		<input checked="" type="checkbox"/> Preliminary Plat <input checked="" type="checkbox"/> Final Plat	
<input type="checkbox"/>	Preliminary Plat Proposed locations, widths and other dimensions of all new streets and utilities, including water mains, storm and sanitary sewer mains, catch basins and culverts, street lights, fire hydrants, sewerage pump stations, etc. (Section IV.10) Final Plat Proposed locations and profiles of all proposed streets and utilities, including water mains, storm and sanitary sewer mains, catchbasins and culverts, together with typical cross sections. Profiles shall be drawn to a horizontal scale of 1"=50' and a vertical scale of 1"=5', showing existing centerline grade, existing left and right sideline grades, and proposed centerline grade. (Section V.9)		<input checked="" type="checkbox"/> Preliminary Plat <input checked="" type="checkbox"/> Final Plat	
<input type="checkbox"/>	When required by the Board, the plat shall be accompanied by profiles of proposed street grades, including extensions for a reasonable distance beyond the subject land; also grades and sizes of proposed utilities. (Section IV.10)		<input checked="" type="checkbox"/> Preliminary Plat <input checked="" type="checkbox"/> Final Plat	
<input type="checkbox"/>	Base flood elevation (BFE) for subdivisions involving greater than five (5) acres or fifty (50) lots. (Section IV.11)		<input checked="" type="checkbox"/> Preliminary Plat <input checked="" type="checkbox"/> Final Plat	
<input type="checkbox"/>	For subdivisions of five (5) lots or more, or at the discretion of the Board otherwise, the preliminary plat shall show contours at intervals no greater than two (2) feet. Contours shall be shown in dotted lines for existing natural surface and in solid lines for proposed final grade, together with the final grade elevations shown in figures at all lot corners. If existing grades are not to be changed, then the contours in these areas shall be solid lines. (Section IV.12/ V.12)		<input checked="" type="checkbox"/> Preliminary Plat <input checked="" type="checkbox"/> Final Plat	

Requirements for Preliminary/Final Plat				
<input checked="" type="checkbox"/>	Required Items for Submittal	Item Location (e.g. Page/line or Plan Sheet/Note #)	Required for Preliminary / Final Plat	Waiver Requested
<input type="checkbox"/>	Dates and permit numbers of all necessary permits from governmental agencies from which approval is required by Federal or State law. (Section V.10)		<input type="checkbox"/> Preliminary Plat <input checked="" type="checkbox"/> Final Plat	
<input type="checkbox"/>	For subdivisions involving greater than five (5) acres or fifty (50) lots, the final plat shall show hazard zones and shall include elevation data for flood hazard zones. (Section V.11)		<input type="checkbox"/> Preliminary Plat <input checked="" type="checkbox"/> Final Plat	
<input type="checkbox"/>	Location of all permanent monuments. (Section V.12)		<input type="checkbox"/> Preliminary Plat <input checked="" type="checkbox"/> Final Plat	

General Requirements¹

<input checked="" type="checkbox"/>	Required Items for Submittal	Item Location (e.g. Page/line or Plan Sheet/Note #)	Waiver Requested
<input type="checkbox"/> <input type="checkbox"/> <input type="checkbox"/> <input type="checkbox"/> <input type="checkbox"/>	1. Basic Requirements: (VI.1) a. Conformity to Official Plan or Map b. Hazards c. Relation to Topography d. Planned Unit Development		
<input type="checkbox"/> <input type="checkbox"/> <input type="checkbox"/> <input type="checkbox"/>	2. Lots: (VI.2) a. Lot Arrangement b. Lot sizes c. Commercial and Industrial Lots		
<input type="checkbox"/> <input type="checkbox"/> <input type="checkbox"/> <input type="checkbox"/> <input type="checkbox"/> <input type="checkbox"/> <input type="checkbox"/> <input type="checkbox"/> <input type="checkbox"/> <input type="checkbox"/> <input type="checkbox"/> <input type="checkbox"/> <input type="checkbox"/> <input type="checkbox"/> <input type="checkbox"/> <input type="checkbox"/> <input type="checkbox"/> <input type="checkbox"/> <input type="checkbox"/> <input type="checkbox"/>	3. Streets: (VI.3) a. Relation to adjoining Street System b. Street Rights-of-Way c. Access d. Parallel Service Roads e. Street Intersection Angles f. Merging Streets g. Street Deflections and Vertical Alignment h. Marginal Access Streets i. Cul-de-Sacs j. Rounding Street Corners k. Street Name Signs l. Street Names m. Block Lengths n. Block Widths o. Grade of Streets p. Grass Strips		
<input type="checkbox"/>	4. Curbing: (VI.4)		
<input type="checkbox"/>	5. Driveways: (VI.5)		
<input type="checkbox"/>	6. Drainage Improvements: (VI.6)		
<input type="checkbox"/>	7. Municipal Water Service: (VI.7)		
<input type="checkbox"/>	8. Municipal Sewer Service: (VI.8)		
<input type="checkbox"/>	9. Installation of Utilities: (VI.9)		
<input type="checkbox"/>	a. All Districts		
<input type="checkbox"/>	b. Indicator Tape		
<input type="checkbox"/>	10. On-Site Water Supply: (VI.10)		
<input type="checkbox"/>	11. On-Site Sewage Disposal Systems: (VI.11)		
<input type="checkbox"/>	12. Open Space: (VI.12)		
<input type="checkbox"/>	a. Natural Features		
<input type="checkbox"/>	b. Buffer Strips		
<input type="checkbox"/>	c. Parks		
<input type="checkbox"/>	d. Tree Planting		
<input type="checkbox"/>	13. Flood Hazard Areas: (VI.13)		
<input type="checkbox"/>	a. Permits		
<input type="checkbox"/>	b. Minimization of Flood Damage		
<input type="checkbox"/>	c. Elevation and Flood-Proofing Records		
<input type="checkbox"/>	d. Alteration of Watercourses		
<input type="checkbox"/>	14. Erosion and Sedimentation Control (VI.14)		

<input checked="" type="checkbox"/>	Required Items for Submittal	Item Location (e.g. Page/line or Plan Sheet/Note #)	Waiver Requested
<input type="checkbox"/>	15. Easements (VI.15) a. Utilities b. Drainage		
<input type="checkbox"/>	16. Monuments: (VI.16)		
<input type="checkbox"/>	17. Benchmarks: (VI.17)		
<input type="checkbox"/>	18. House Numbers (VI.18)		

Design Standards			
	Required Items for Submittal	Indicate compliance and/or provide explanation as to alternative design	Waiver Requested
<input type="checkbox"/>	1. Streets have been designed according to the design standards required under Section (VII.1). a. Clearing b. Excavation c. Rough Grade and Preparation of Sub-Grade d. Base Course e. Street Paving f. Side Slopes g. Approval Specifications h. Curbing i. Sidewalks j. Inspection and Methods		
<input type="checkbox"/>	2. Storm water Sewers and Other Drainage Appurtenances have been designed according to the design standards required under Section (VII.2). a. Design b. Standards of Construction		
<input type="checkbox"/>	3. Sanitary Sewers have been designed according to the design standards required under Section (VII.3). a. Design b. Lift Stations c. Materials d. Construction Standards		
<input type="checkbox"/>	4. Water Mains and Fire Hydrants have been designed according to the design standards required under Section (VII.4). a. Connections to Lots b. Design and Construction c. Materials d. Notification Prior to Construction		

Applicant's/Representative's Signature: _____ Date: _____

¹ See City of Portsmouth, NH Subdivision Rules and Regulations for details.
Subdivision Application Checklist/January 2018

Letter of Authorization

I, Marissa Valverde, owner of the property located at 20 Central Avenue Portsmouth, NH 03801, do hereby authorize the following parties to act as agents on our behalf for the above-described property in order to apply for any necessary federal, state and local applications or permits on the subject property relative to the development of said parcel:

Ambrosia Development & Investments and/or assigns and his hired parties to include but not limited to:

Haley Ward Engineering Portsmouth, NH

Exeter Environmental Newfields, NH

And all other engineers, surveyors, and agents as appointed by Ambrosia Development & Investments, LLC and/or assigns as agents to act on my behalf in matters to be discussed with the City of Portsmouth, State Departments and other Land Use Boards concerning the property previously mentioned and to access the subject property for completion of Due Diligence and in accordance with any work required for said permits.

I hereby appoint the above referenced parties as my agent to act on my behalf in the review process, to include any required signatures.

DocuSigned by:
Marissa Valverde
65A41364221B490...

3/24/2026

Marissa Valverde

Date

Site Plan Review Application Fee – FY25

Project:

Map/Lot:

Applicant:

All development

Base fee \$600

\$600.00

Plus \$5.00 per \$1,000 of site costs

Site costs

\$200,000

+ \$1,000.00

Plus \$10.00 per 1,000 S.F. of site development area

Site development area

29,000 S.F.

+ \$290.00

Fee \$1,890.00

Maximum fee: \$20,000.00

Fee received by: _____

Date: _____

Note: Initial application fee may be based on the applicant's estimates of site costs and site development area. Following site plan approval, the application fee will be recalculated based on the approved site plan and site engineer's corresponding site cost estimate as approved by the Department of Public Works, and any additional fee shall be paid prior to the issuance of a building permit.

Construction Cost Estimate

Haley Ward, Inc

Date: June 22, 2026

Project: Proposed Multifamily Development Job No: 5010658.001

Location: 20 Central Avenue, Portsmouth, NH - **On Site**

Scope: **Site Cost Estimate**

ITEM NO	DESCRIPTION	UNIT	AMOUNT	UNIT COST	TOTAL
1	Mobilization	EA	1	\$10,000.00	\$10,000.00
2	Site Clearing & Demolition	LS	1	\$20,000.00	\$20,000.00
3	SiltSoxx	LF	390	\$8.00	\$3,120.00
4	Base Gravel (Type A)	CY	50	\$50.00	\$2,500.00
5	Common Borrow	CY	300	\$30.00	\$9,000.00
6	Surface Asphalt	TN	50	\$110.00	\$5,500.00
7	6" SDR-35 Sanitary Sewer	LF	190	\$120.00	\$22,800.00
8	Water Service	LF	190	\$145.00	\$27,550.00
9	Underground Electric & Cable	LF	300	\$85.00	\$25,500.00
10	Manhole Modifications	EA	2	\$1,000.00	\$2,000.00
11	Rain Garden	EA	2	\$5,000.00	\$10,000.00
12	Landscaping	LS	1	\$30,000.00	\$30,000.00
13	Loam & Seed	SY	1400	\$21.00	\$29,400.00
	TOTAL				\$197,370



SITE PHOTOS
20 CENTRAL AVENUE
PORTSMOUTH, NH 03801



Figure 1 – Site view from Central Avenue, looking southeast.



Figure 2 – Site view from the intersection of Central Avenue and Beechwood Street, looking north.

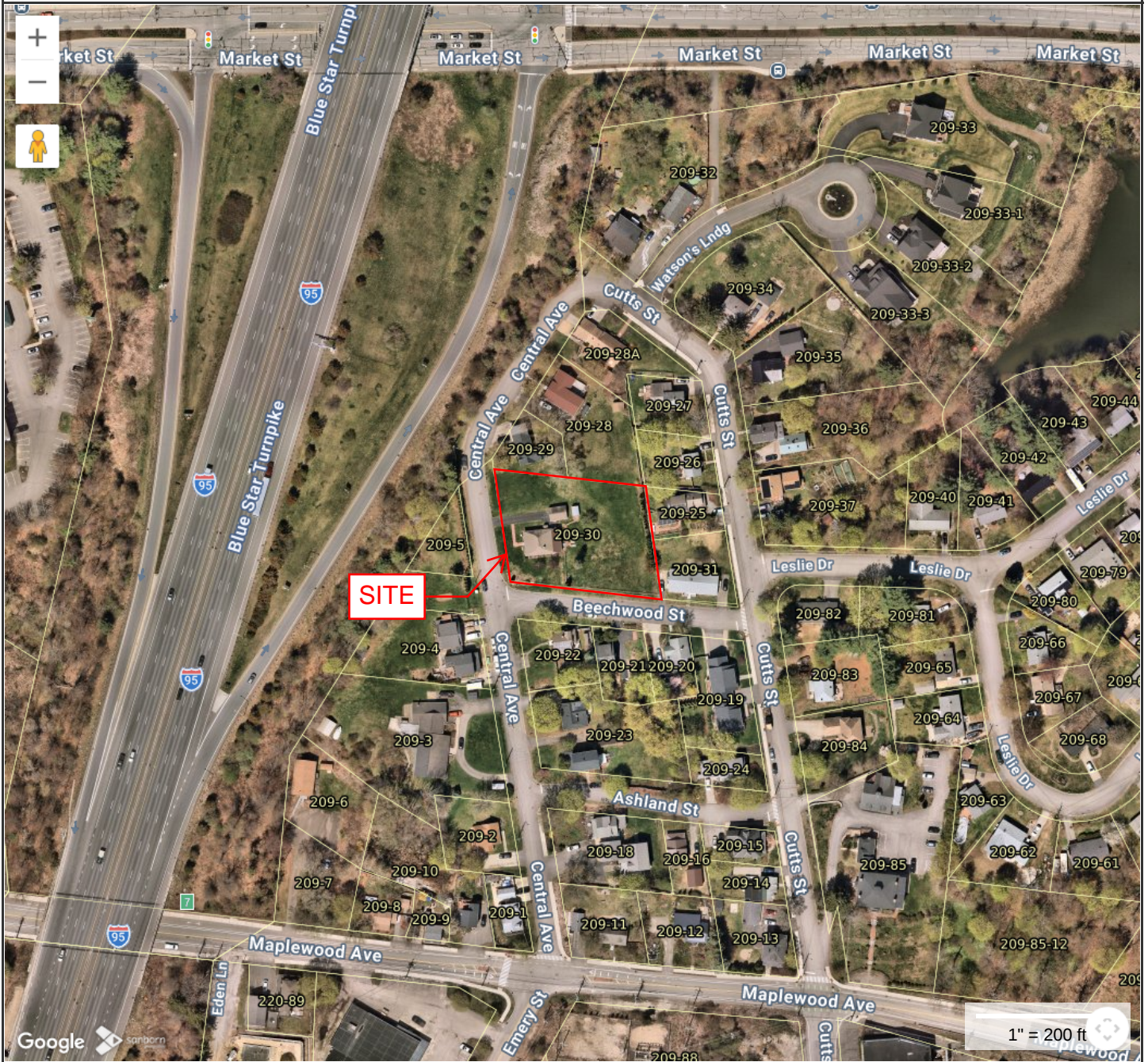

Figure 3 – Site view from the intersection of Central Avenue and Beechwood Street, looking east.



Figure 4 - Site view from Beechwood Street, looking northwest.

Tax Map



**MAP FOR REFERENCE ONLY
NOT A LEGAL DOCUMENT**

City of Portsmouth, NH makes no claims and no warranties, expressed or implied, concerning the validity or accuracy of the GIS data presented on this map.

Geometry updated 03/06/2026

Print map scale is approximate. Critical layout or measurement activities should not be done using this resource.

Zoning Map



**MAP FOR REFERENCE ONLY
NOT A LEGAL DOCUMENT**

City of Portsmouth, NH makes no claims and no warranties, expressed or implied, concerning the validity or accuracy of the GIS data presented on this map.







Geometry updated 03/06/2026

Print map scale is approximate. Critical layout or measurement activities should not be done using this resource.

Map Theme Legends

Zoning

Residential Districts

	R	Rural
	SRA	Single Residence A
	SRB	Single Residence B
	GRA	General Residence A
	GRB	General Residence B
	GRC	General Residence C
	GA/MH	Garden Apartment/Mobile Home Park



Mixed Residential Districts

	MRO	Mixed Residential Office
	MRB	Mixed Residential Business
	G1	Gateway Corridor
	G2	Gateway Center





Business Districts

	GB	General Business
	B	Business
	WB	Waterfront Business



Industrial Districts

	OR	Office Research
	I	Industrial
	WI	Waterfront Industrial





Airport Districts

	AIR	Airport
	AI	Airport Industrial
	PI	Pease Industrial
	ABC	Airport Business Commercial

Conservation Districts

	M	Municipal
	NRP	Natural Resource Protection

Character Districts

	CD5	Character District 5
	CD4	Character District 4
	CD4W	Character District 4-W
	CD4-L1	Character District 4-L1
	CD4-L2	Character District 4-L2



Civic District

	Civic District
---	----------------

Municipal District

	Municipal District
---	--------------------

Overlay Districts

	OLOD	Osprey Landing Overlay District
	Downtown Overlay District	
	Historic District	

City of Portsmouth

June 22, 2026

Peter Stith, TAC Committee Chair
City of Portsmouth
1 Junkins Avenue
Portsmouth, NH 03801

**RE: Trip Generation Letter
20 Central Avenue
Proposed Multifamily Development**

INTRODUCTION

On behalf of Copley Properties (Copley), we hereby submit this Trip Generation Letter in support of the applicant's filing with the Portsmouth Technical Advisory Committee for Site Plan approval. Copley seeks to construct 3 single-family residential units under a condominium agreement at the site, which is currently occupied by the owner, Marissa Valverde.

TRIP GENERATION

Trip Generation for the site has been calculated using the Institute of Transportation Engineer's (ITE) publication, Trip Generation, 12th Edition. Land Use Code (LUC) 180 – Specialty Trade Contractor was selected for the existing use and 210 – Single-Family Detached Housing was selected for the proposed use. Below is a summary of the existing and proposed AM and PM Peak Hour Trips for the site.

EXISTING TRAFFIC

Weekday AM Peak Hour of Generator = 0.75 Trips per Dwelling Unit (LUC 210)
Dwelling Units = 1
1 X 0.75 Trip Ends = **1 trip** (27% entering, 73% exiting)

Weekday PM Peak Hour of Generator = 0.97 Trips per Dwelling Unit (LUC 210)
Dwelling Units = 1
1 X 0.97 Trip Ends = **1 trip** (63% entering; 37% exiting)

PROPOSED TRAFFIC

Weekday AM Peak Hour of Generator = 0.75 Trips per Dwelling Unit (LUC 210)
Dwelling Units = 3
3 X 0.75 Trip Ends = **3 trips** (27% entering, 73% exiting)

Weekday PM Peak Hour of Generator = 0.97 Trips per Dwelling Unit (LUC 210)
Dwelling Units = 3



3 X 0.97 Trip Ends = **3 trips** (63% entering; 37% exiting)

CONCLUSION

As demonstrated above, the proposed project will result in an insignificant increase for the number of trips in both the Weekday AM and PM Peak hours. Therefore, the proposed development will not affect the traffic patterns of the surrounding neighborhood.

Sincerely,
Haley Ward, Inc.

Drew Olehowski, PE
Project Manager

Land Use: 210

Single-Family Detached Housing

Description

A single-family detached housing site includes any single-family detached home on an individual lot. A typical site surveyed is a suburban subdivision.

Specialized Land Use

Data have been submitted for several single-family detached housing developments with homes that are commonly referred to as patio homes. A patio home is a detached housing unit that is located on a small lot with little (or no) front or back yard. In some subdivisions, communal maintenance of outside grounds is provided for the patio homes. The three patio home sites total 299 dwelling units with overall weighted average trip generation rates of 5.35 vehicle trips per dwelling unit for weekday, 0.26 for the AM adjacent street peak hour, and 0.47 for the PM adjacent street peak hour. These patio home rates, based on a small sample of sites, are lower than those for single-family detached housing (Land Use 210), lower than those for single-family attached housing (Land Use 215), and higher than those for senior adult housing—single-family (Land Use 251). (Source 1008)

Additional Data

The sites were surveyed in the 1990s, the 2000s, the 2010s, and the 2020s in Alabama, Arizona, British Columbia (CAN), California, Delaware, Illinois, Kentucky, Massachusetts, Minnesota, Montana, New Jersey, New York, North Carolina, Ontario (CAN), Oregon, Pennsylvania, South Carolina, South Dakota, Vermont, and West Virginia.

Source Numbers

356, 357, 367, 384, 387, 407, 435, 522, 550, 552, 579, 598, 601, 603, 614, 637, 711, 716, 720, 728, 735, 868, 869, 903, 925, 936, 1005, 1007, 1008, 1010, 1033, 1066, 1077, 1078, 1079, 1204, 1221, 1225, 1236, 1251, 1265, 1267

Single-Family Detached Housing (210)

Vehicle Trip Ends vs: Dwelling Units
On a: Weekday

Setting/Location: General Urban/Suburban

Number of Studies: 155

Avg. Num. of Dwelling Units: 261

Directional Distribution: 50% entering, 50% exiting

Vehicle Trip Generation per Dwelling Unit

Average Rate	Range of Rates	Standard Deviation
9.09	3.47 - 23.80	2.29

Data Plot and Equation

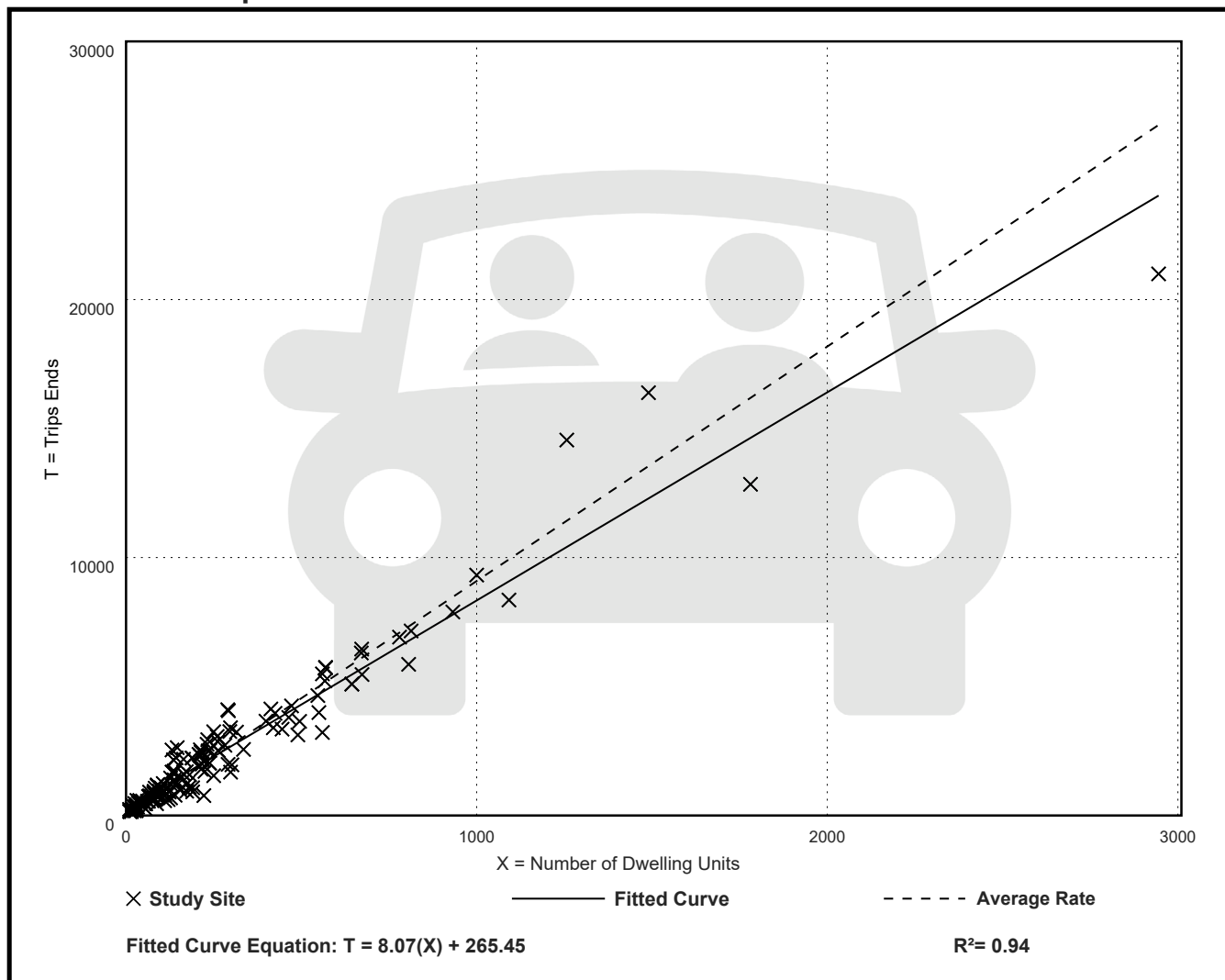

Single-Family Detached Housing (210)

Vehicle Trip Ends vs: Dwelling Units

On a: Weekday,

Peak Hour of Adjacent Street Traffic,
One Hour Between 7 and 9 a.m.

Setting/Location: General Urban/Suburban

Number of Studies: 153

Avg. Num. of Dwelling Units: 239

Directional Distribution: 27% entering, 73% exiting

Vehicle Trip Generation per Dwelling Unit

Average Rate	Range of Rates	Standard Deviation
0.70	0.22 - 2.27	0.26

Data Plot and Equation

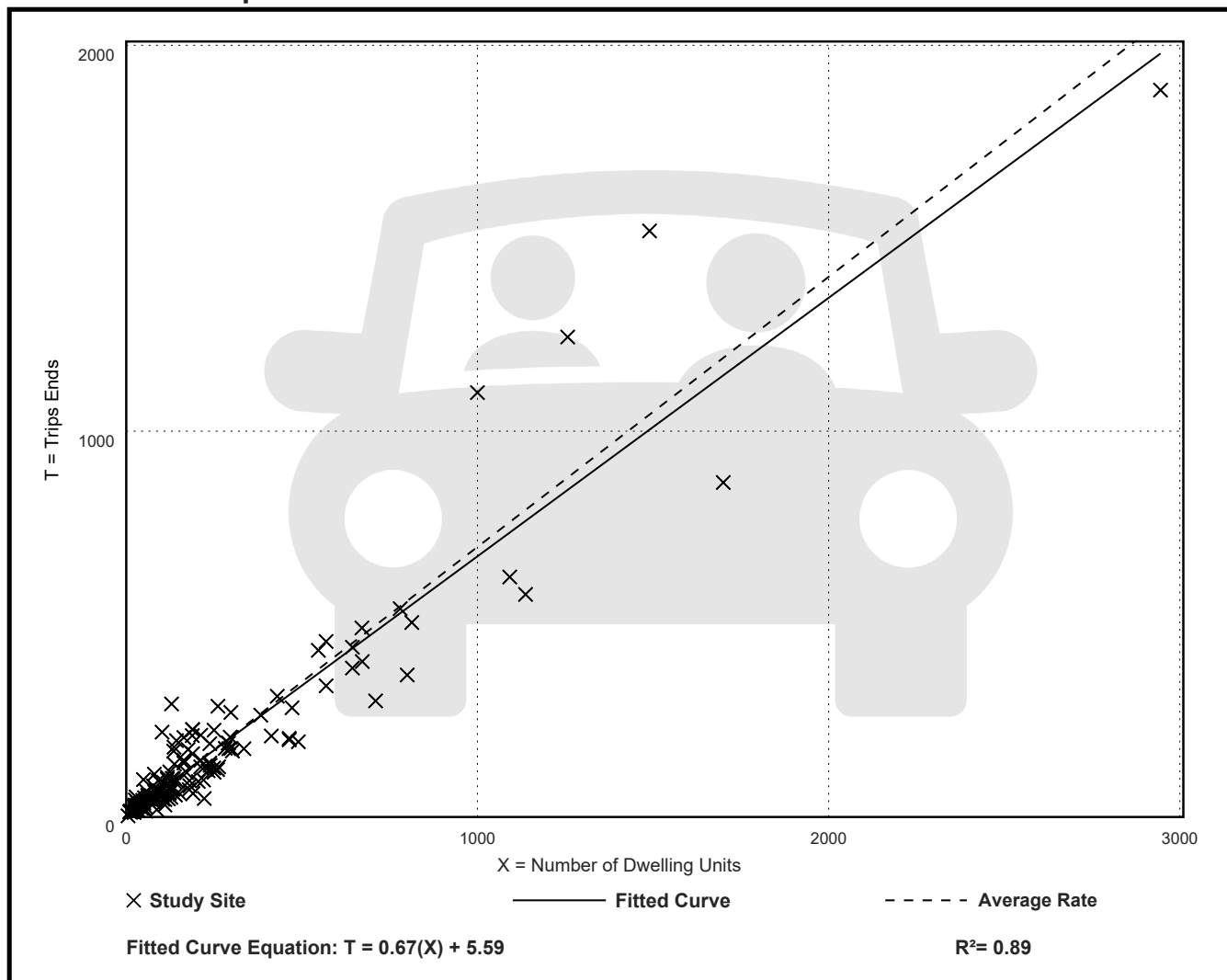

Single-Family Detached Housing (210)

Vehicle Trip Ends vs: Dwelling Units

On a: Weekday,

Peak Hour of Adjacent Street Traffic,
One Hour Between 4 and 6 p.m.

Setting/Location: General Urban/Suburban

Number of Studies: 166

Avg. Num. of Dwelling Units: 266

Directional Distribution: 62% entering, 38% exiting

Vehicle Trip Generation per Dwelling Unit

Average Rate	Range of Rates	Standard Deviation
0.93	0.35 - 2.98	0.33

Data Plot and Equation

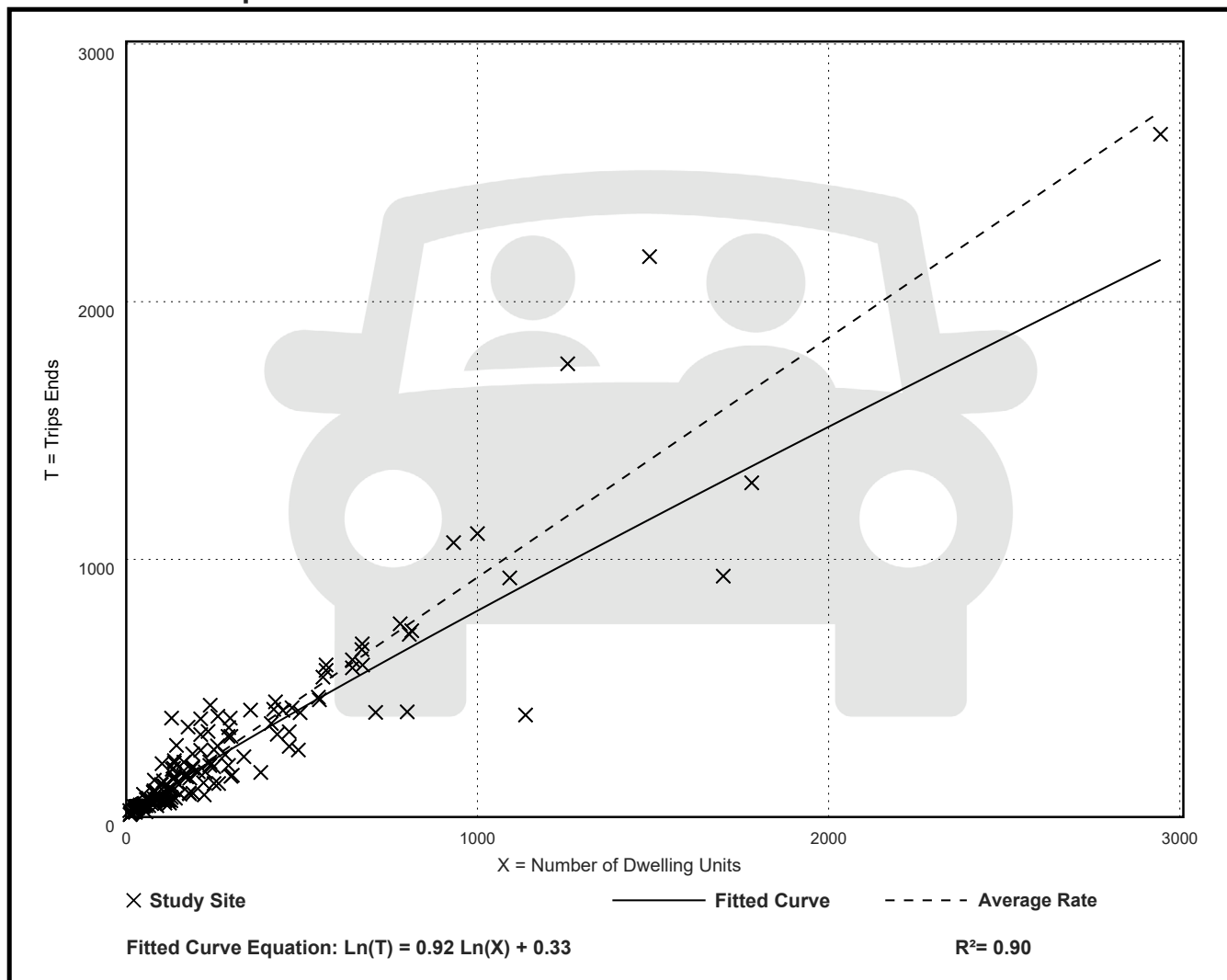

Single-Family Detached Housing (210)

Vehicle Trip Ends vs: Dwelling Units

On a: Weekday,

AM Peak Hour of Generator

Setting/Location: General Urban/Suburban

Number of Studies: 132

Avg. Num. of Dwelling Units: 232

Directional Distribution: 27% entering, 73% exiting

Vehicle Trip Generation per Dwelling Unit

Average Rate	Range of Rates	Standard Deviation
0.75	0.32 - 2.27	0.26

Data Plot and Equation

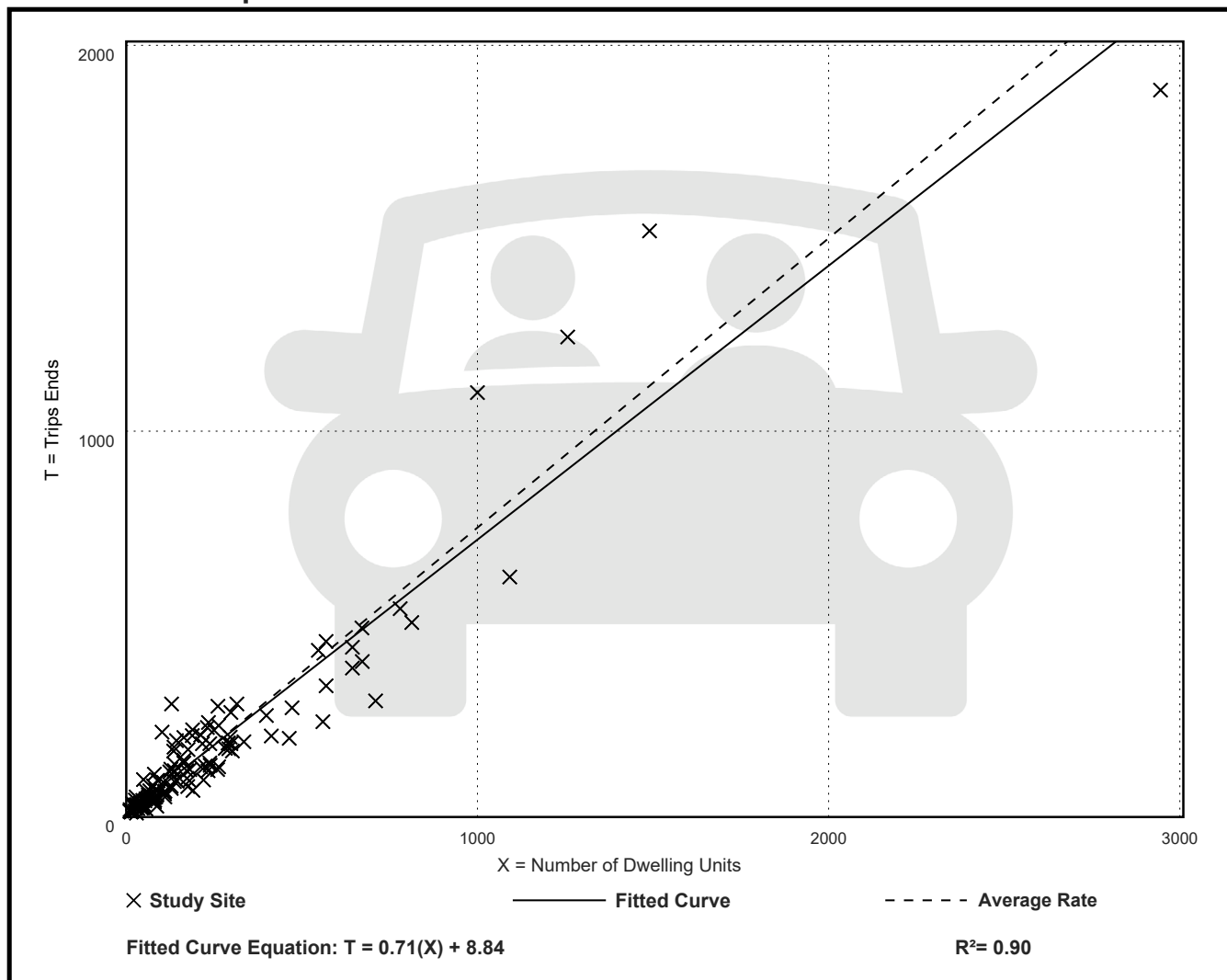

Single-Family Detached Housing (210)

Vehicle Trip Ends vs: Dwelling Units

On a: Weekday,
PM Peak Hour of Generator

Setting/Location: General Urban/Suburban

Number of Studies: 138

Avg. Num. of Dwelling Units: 214

Directional Distribution: 63% entering, 37% exiting

Vehicle Trip Generation per Dwelling Unit

Average Rate	Range of Rates	Standard Deviation
0.97	0.49 - 2.98	0.32

Data Plot and Equation

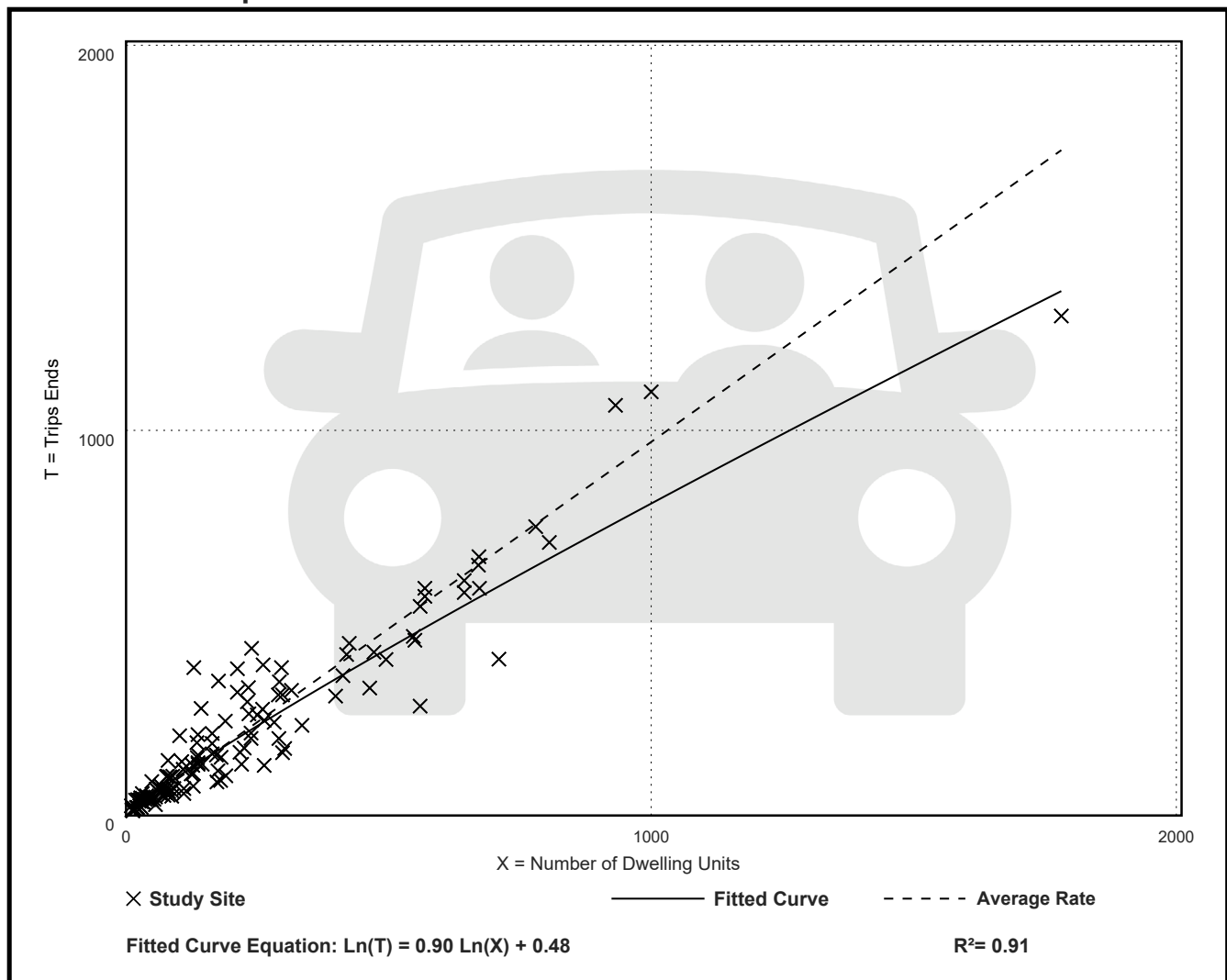

Single-Family Detached Housing (210)

Vehicle Trip Ends vs: Dwelling Units
On a: Saturday

Setting/Location: General Urban/Suburban
Number of Studies: 42
Avg. Num. of Dwelling Units: 159
Directional Distribution: 50% entering, 50% exiting

Vehicle Trip Generation per Dwelling Unit

Average Rate	Range of Rates	Standard Deviation
9.03	3.36 - 28.90	2.51

Data Plot and Equation

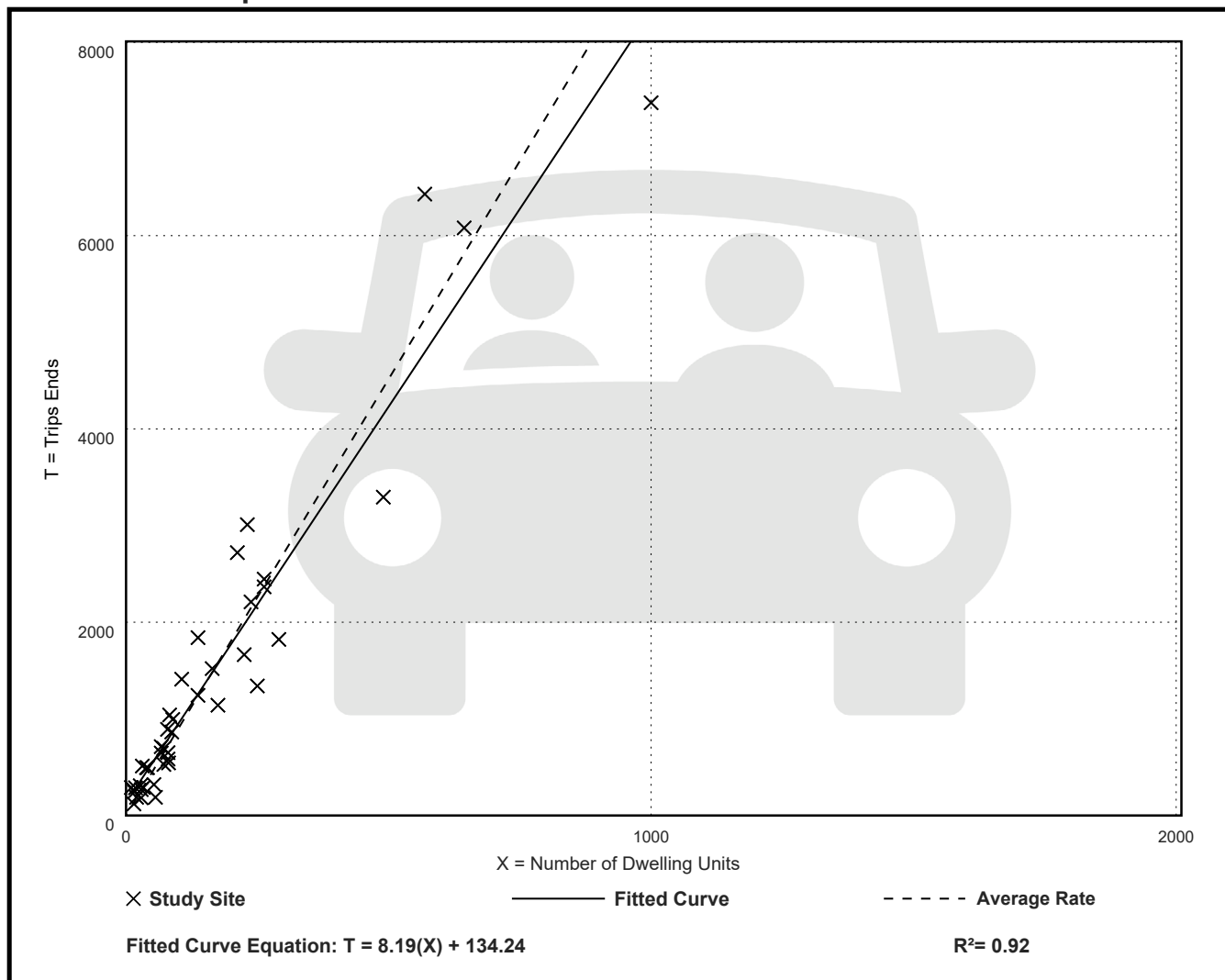

Single-Family Detached Housing (210)

Vehicle Trip Ends vs: Dwelling Units

On a: Saturday, Peak Hour of Generator

Setting/Location: General Urban/Suburban

Number of Studies: 33

Avg. Num. of Dwelling Units: 106

Directional Distribution: 53% entering, 47% exiting

Vehicle Trip Generation per Dwelling Unit

Average Rate	Range of Rates	Standard Deviation
1.00	0.41 - 2.90	0.36

Data Plot and Equation

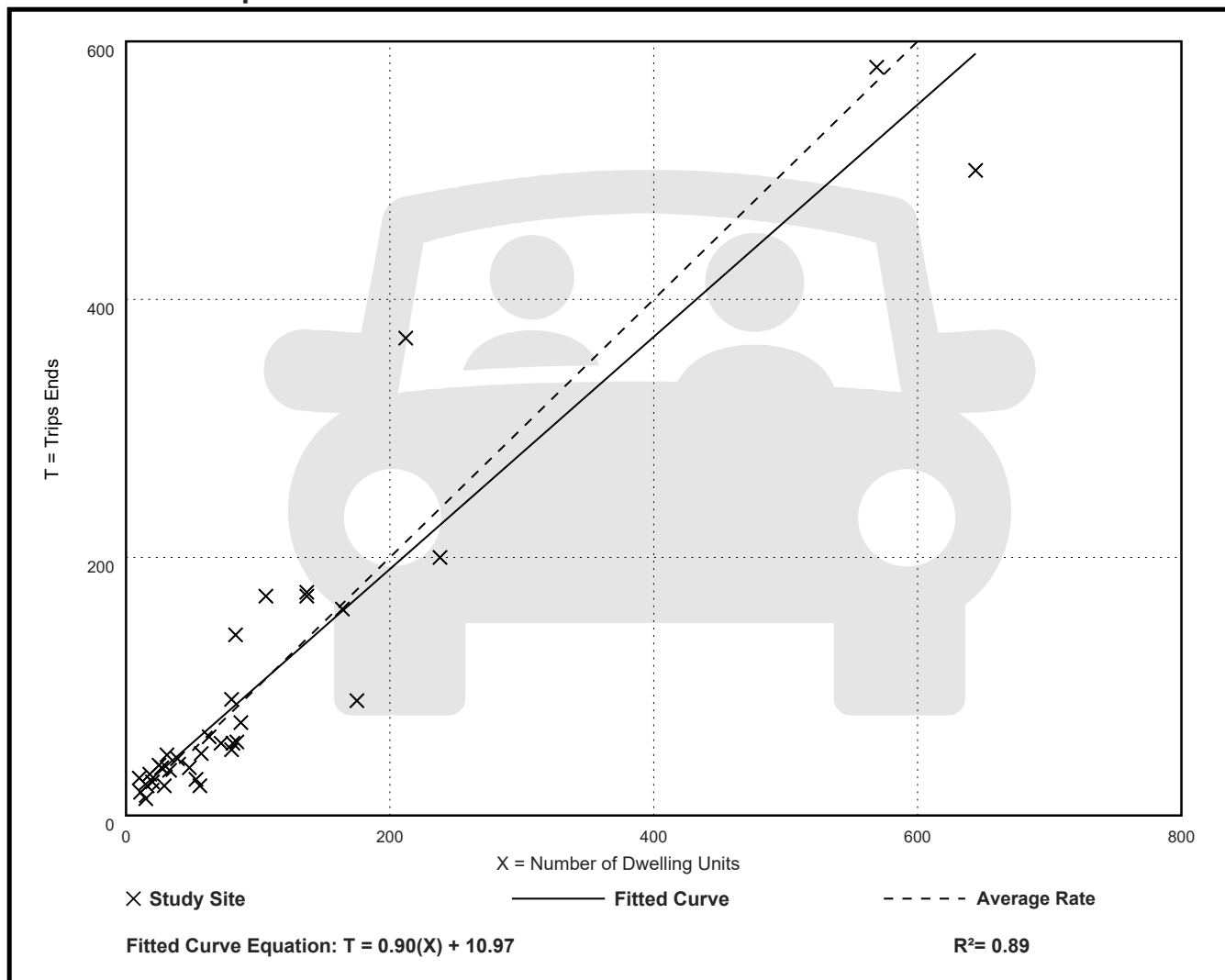

Single-Family Detached Housing (210)

Vehicle Trip Ends vs: Dwelling Units
On a: Sunday

Setting/Location: General Urban/Suburban
Number of Studies: 38
Avg. Num. of Dwelling Units: 172
Directional Distribution: 50% entering, 50% exiting

Vehicle Trip Generation per Dwelling Unit

Average Rate	Range of Rates	Standard Deviation
8.43	2.61 - 16.44	1.73

Data Plot and Equation

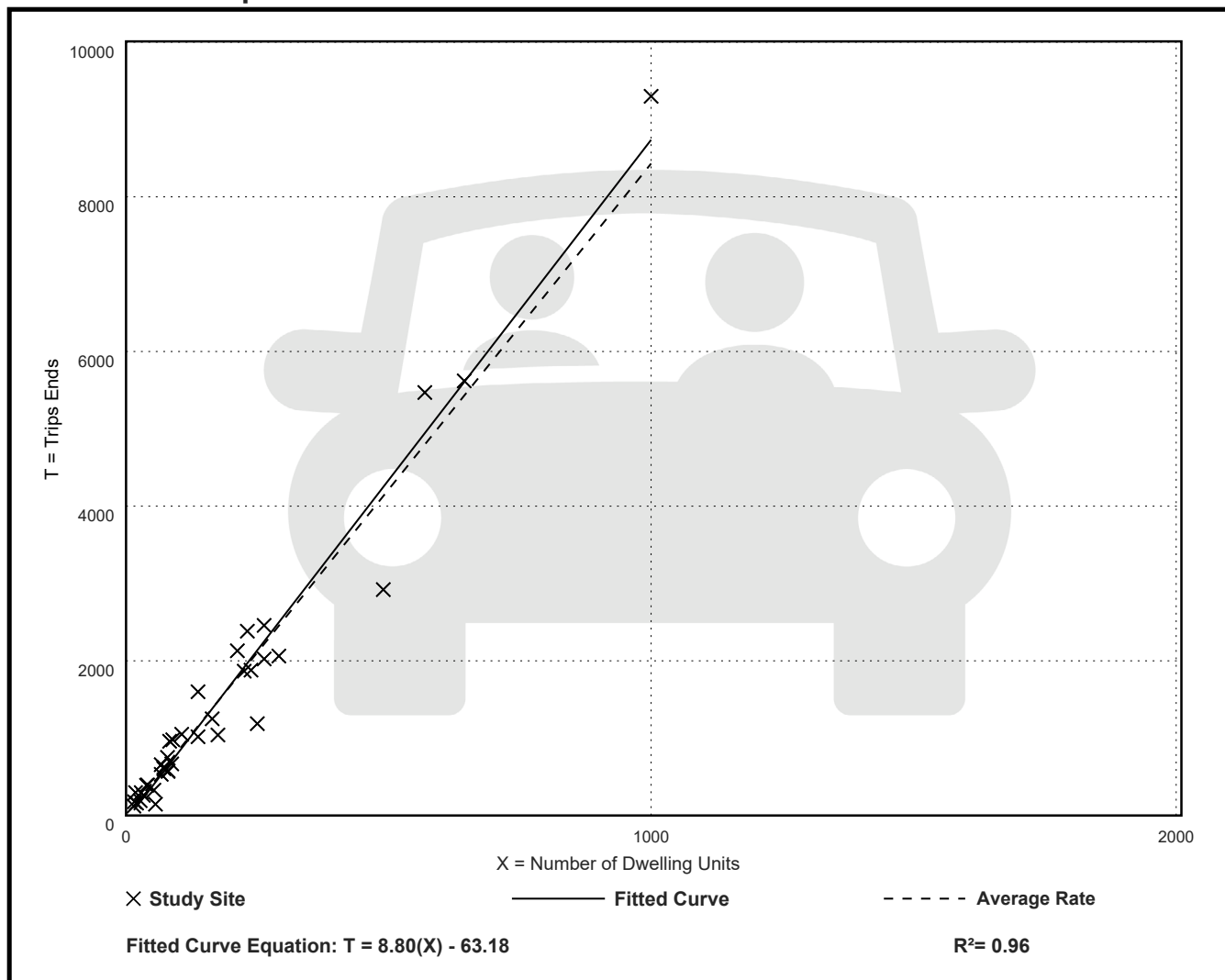

Single-Family Detached Housing (210)

Vehicle Trip Ends vs: Dwelling Units

On a: Sunday, Peak Hour of Generator

Setting/Location: General Urban/Suburban

Number of Studies: 26

Avg. Num. of Dwelling Units: 130

Directional Distribution: 53% entering, 47% exiting

Vehicle Trip Generation per Dwelling Unit

Average Rate	Range of Rates	Standard Deviation
0.91	0.36 - 2.15	0.23

Data Plot and Equation

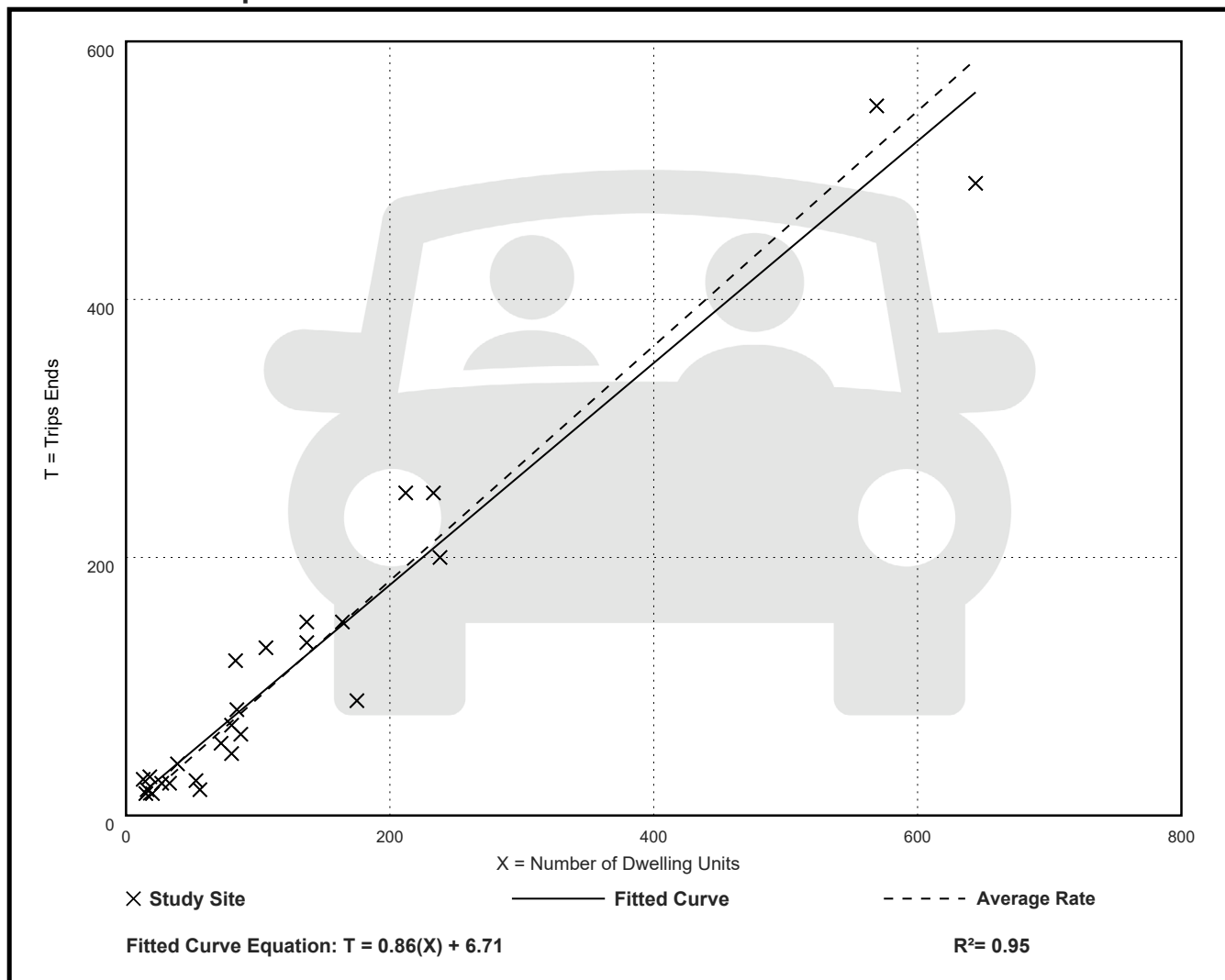

Single-Family Detached Housing (210)

Vehicle Trip Ends vs: Residents
On a: Weekday

Setting/Location: General Urban/Suburban
Number of Studies: 30
Avg. Num. of Residents: 810
Directional Distribution: 50% entering, 50% exiting

Vehicle Trip Generation per Resident

Average Rate	Range of Rates	Standard Deviation
2.65	1.56 - 5.62	0.64

Data Plot and Equation

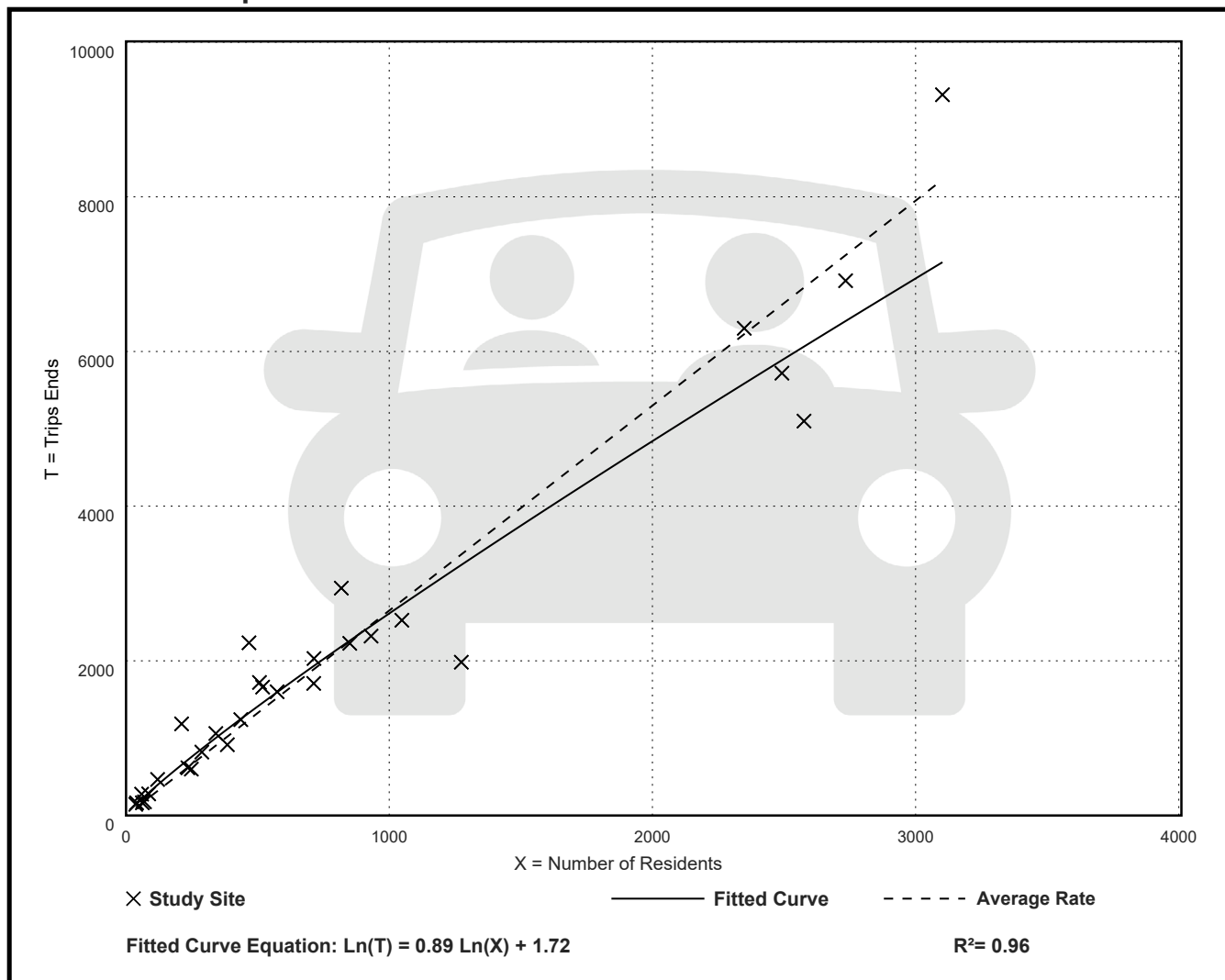

Single-Family Detached Housing (210)

Vehicle Trip Ends vs: Residents

On a: Weekday,

Peak Hour of Adjacent Street Traffic,
One Hour Between 7 and 9 a.m.

Setting/Location: General Urban/Suburban

Number of Studies: 21

Avg. Num. of Residents: 1100

Directional Distribution: 31% entering, 69% exiting

Vehicle Trip Generation per Resident

Average Rate	Range of Rates	Standard Deviation
0.21	0.12 - 0.42	0.08

Data Plot and Equation

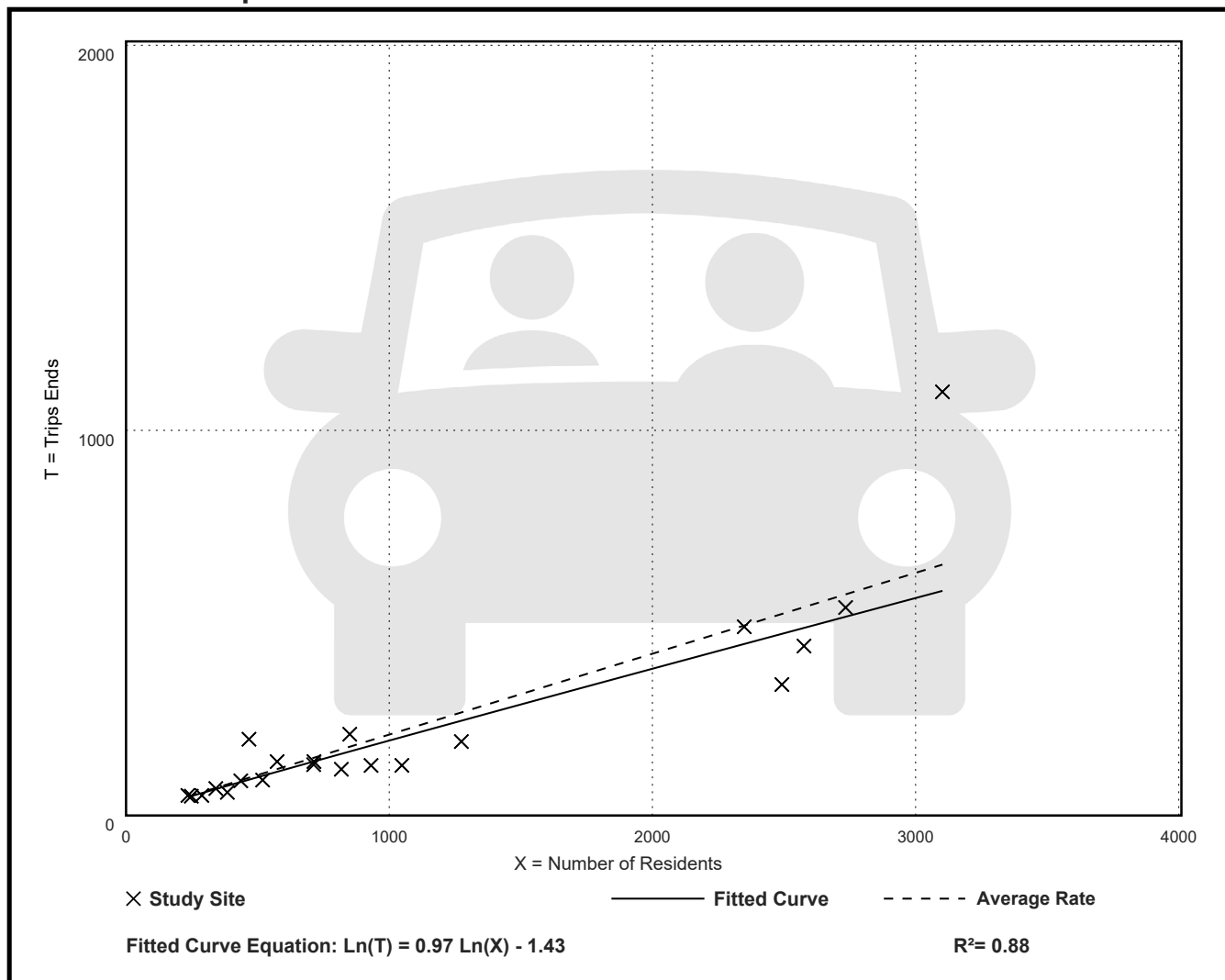

Single-Family Detached Housing (210)

Vehicle Trip Ends vs: Residents

On a: Weekday,

Peak Hour of Adjacent Street Traffic,
One Hour Between 4 and 6 p.m.

Setting/Location: General Urban/Suburban

Number of Studies: 21

Avg. Num. of Residents: 1083

Directional Distribution: 66% entering, 34% exiting

Vehicle Trip Generation per Resident

Average Rate	Range of Rates	Standard Deviation
0.28	0.12 - 0.60	0.08

Data Plot and Equation

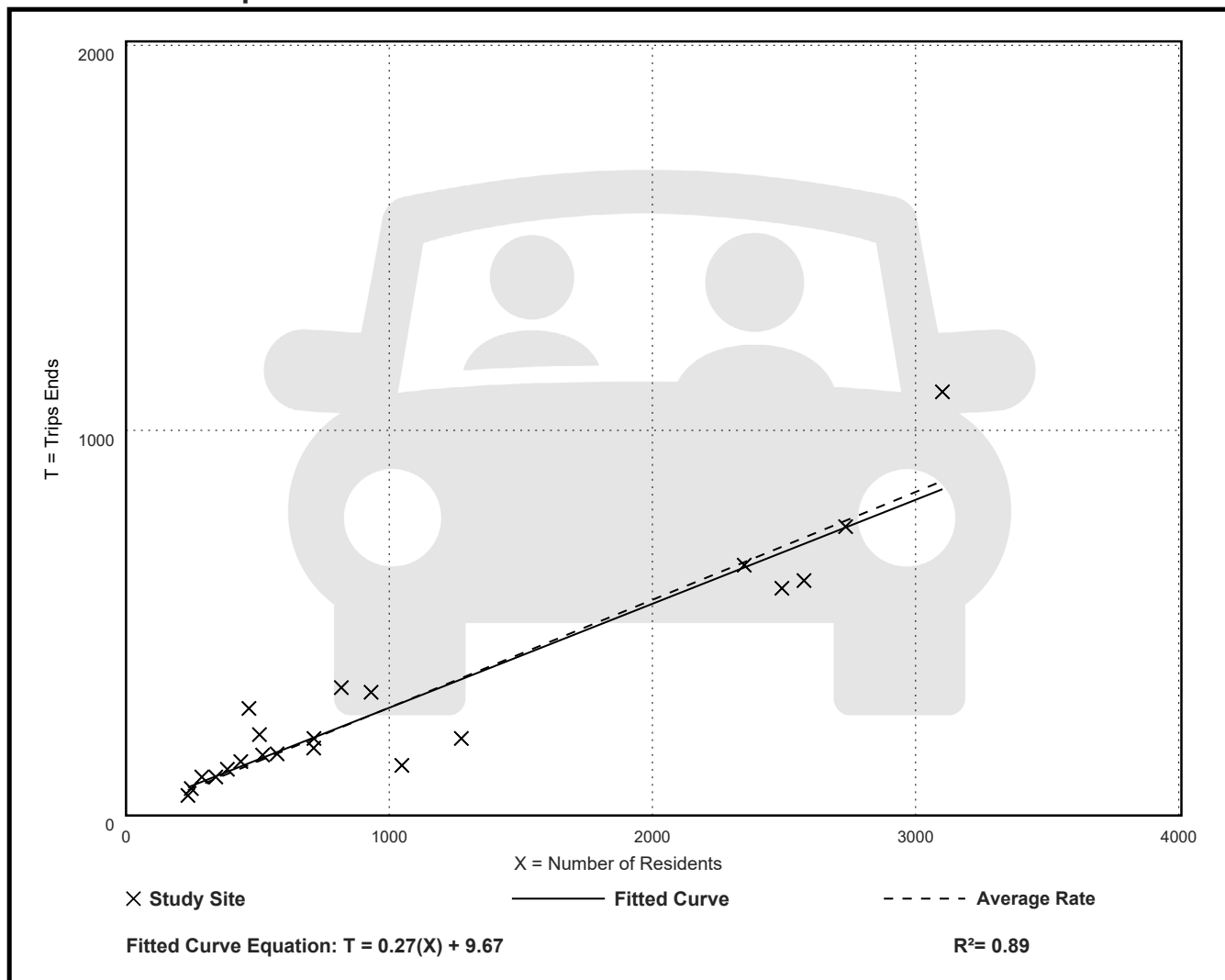

Single-Family Detached Housing (210)

Vehicle Trip Ends vs: Residents

On a: Weekday,

AM Peak Hour of Generator

Setting/Location: General Urban/Suburban

Number of Studies: 22

Avg. Num. of Residents: 1073

Directional Distribution: 30% entering, 70% exiting

Vehicle Trip Generation per Resident

Average Rate	Range of Rates	Standard Deviation
0.21	0.12 - 0.42	0.08

Data Plot and Equation

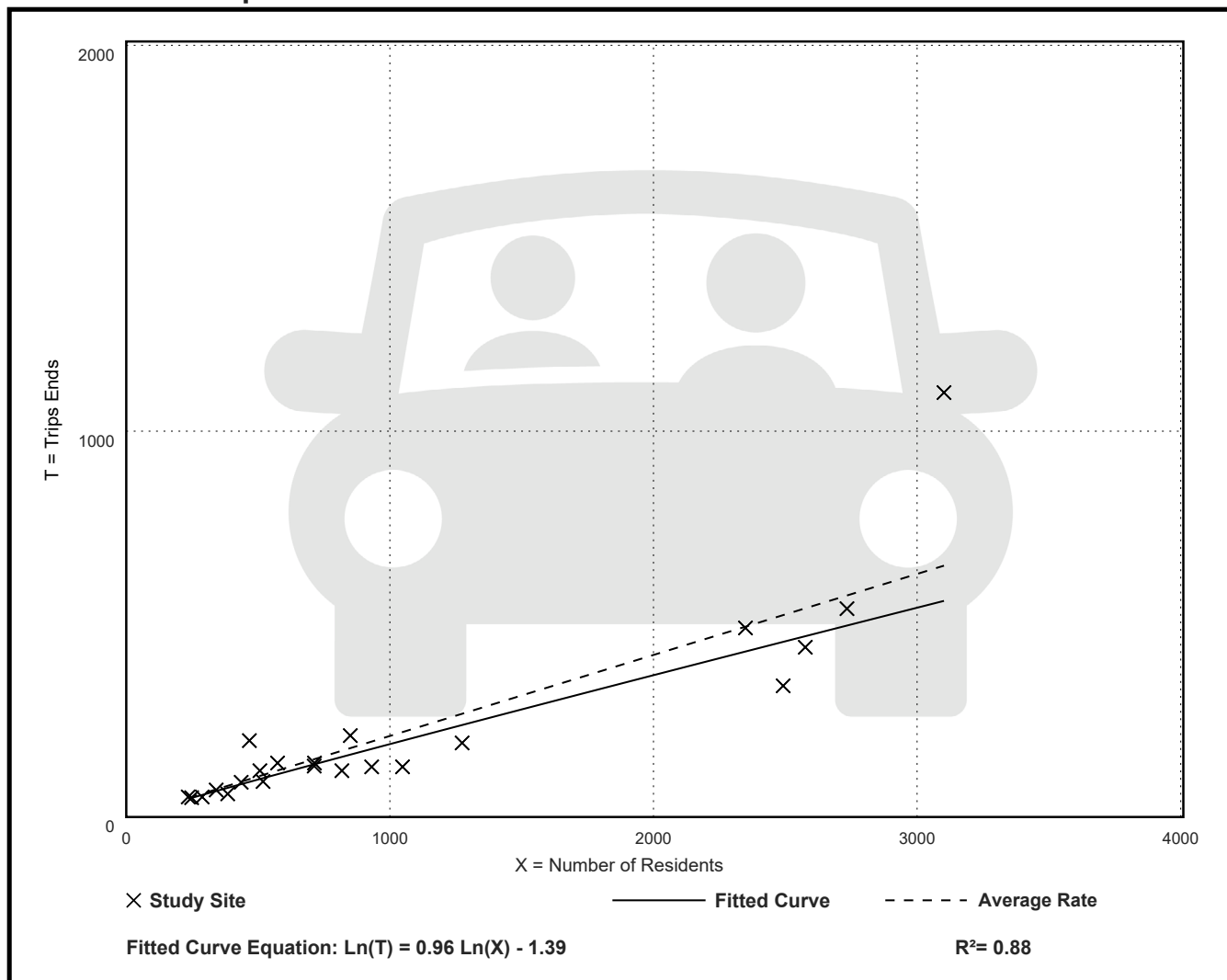

Single-Family Detached Housing (210)

Vehicle Trip Ends vs: Residents

On a: Weekday,

PM Peak Hour of Generator

Setting/Location: General Urban/Suburban

Number of Studies: 21

Avg. Num. of Residents: 1083

Directional Distribution: 66% entering, 34% exiting

Vehicle Trip Generation per Resident

Average Rate	Range of Rates	Standard Deviation
0.28	0.12 - 0.60	0.08

Data Plot and Equation

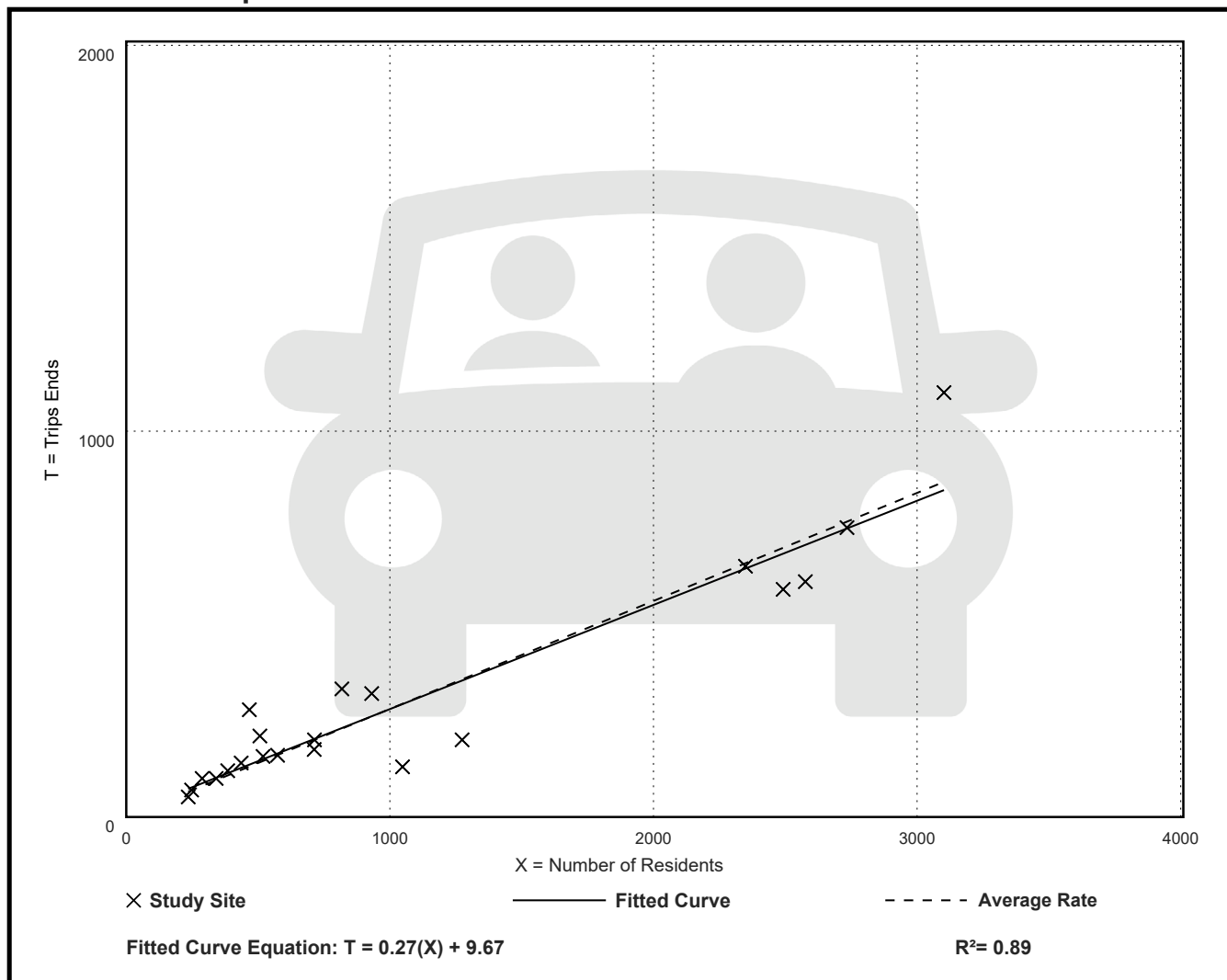

Single-Family Detached Housing (210)

Vehicle Trip Ends vs: Residents
On a: Saturday

Setting/Location: General Urban/Suburban
Number of Studies: 14
Avg. Num. of Residents: 1085
Directional Distribution: 50% entering, 50% exiting

Vehicle Trip Generation per Resident

Average Rate	Range of Rates	Standard Deviation
2.48	1.43 - 3.63	0.46

Data Plot and Equation

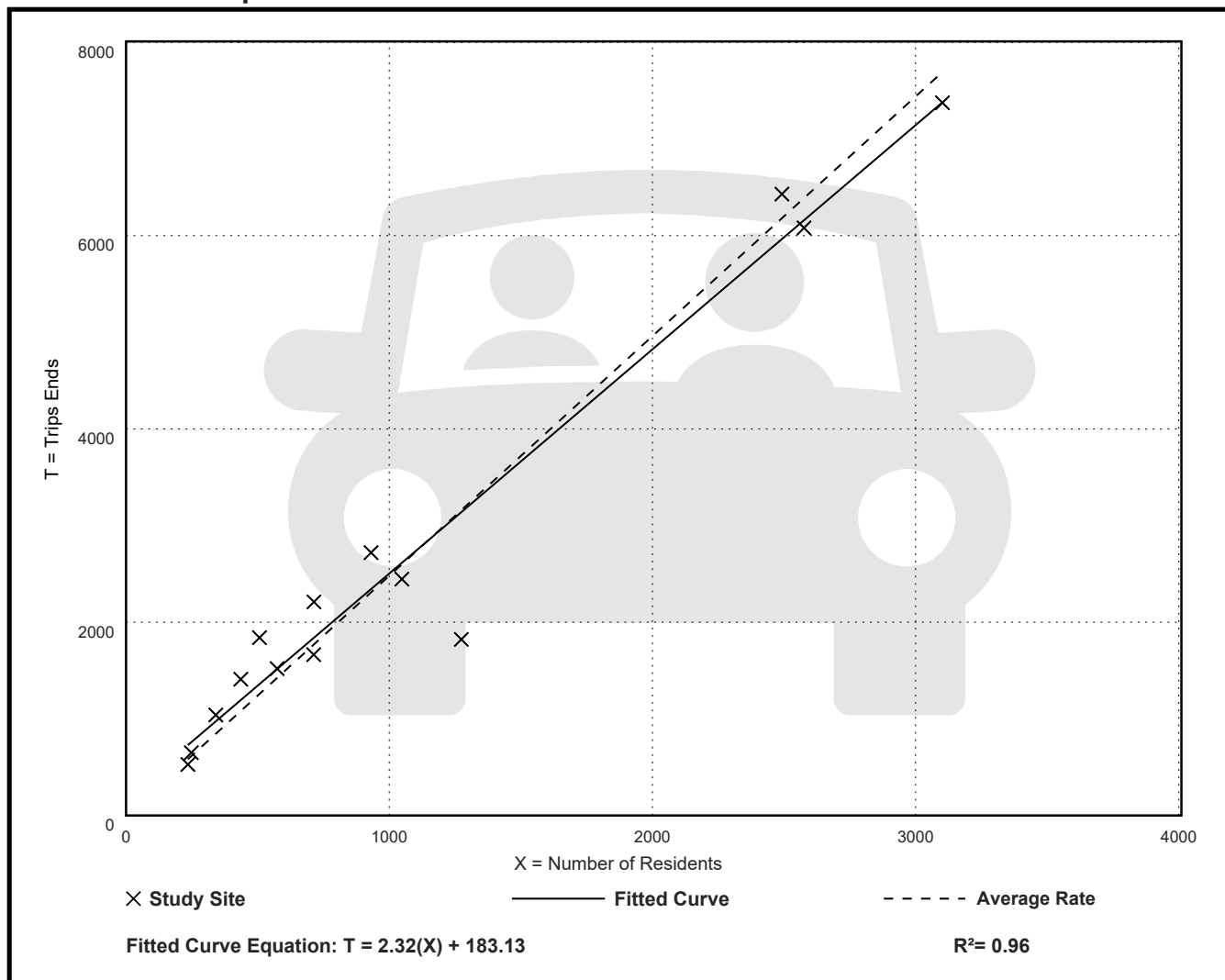

Single-Family Detached Housing (210)

Vehicle Trip Ends vs: Residents

On a: Saturday, Peak Hour of Generator

Setting/Location: General Urban/Suburban

Number of Studies: 11

Avg. Num. of Residents: 875

Directional Distribution: 54% entering, 46% exiting

Vehicle Trip Generation per Resident

Average Rate	Range of Rates	Standard Deviation
0.27	0.19 - 0.41	0.08

Data Plot and Equation

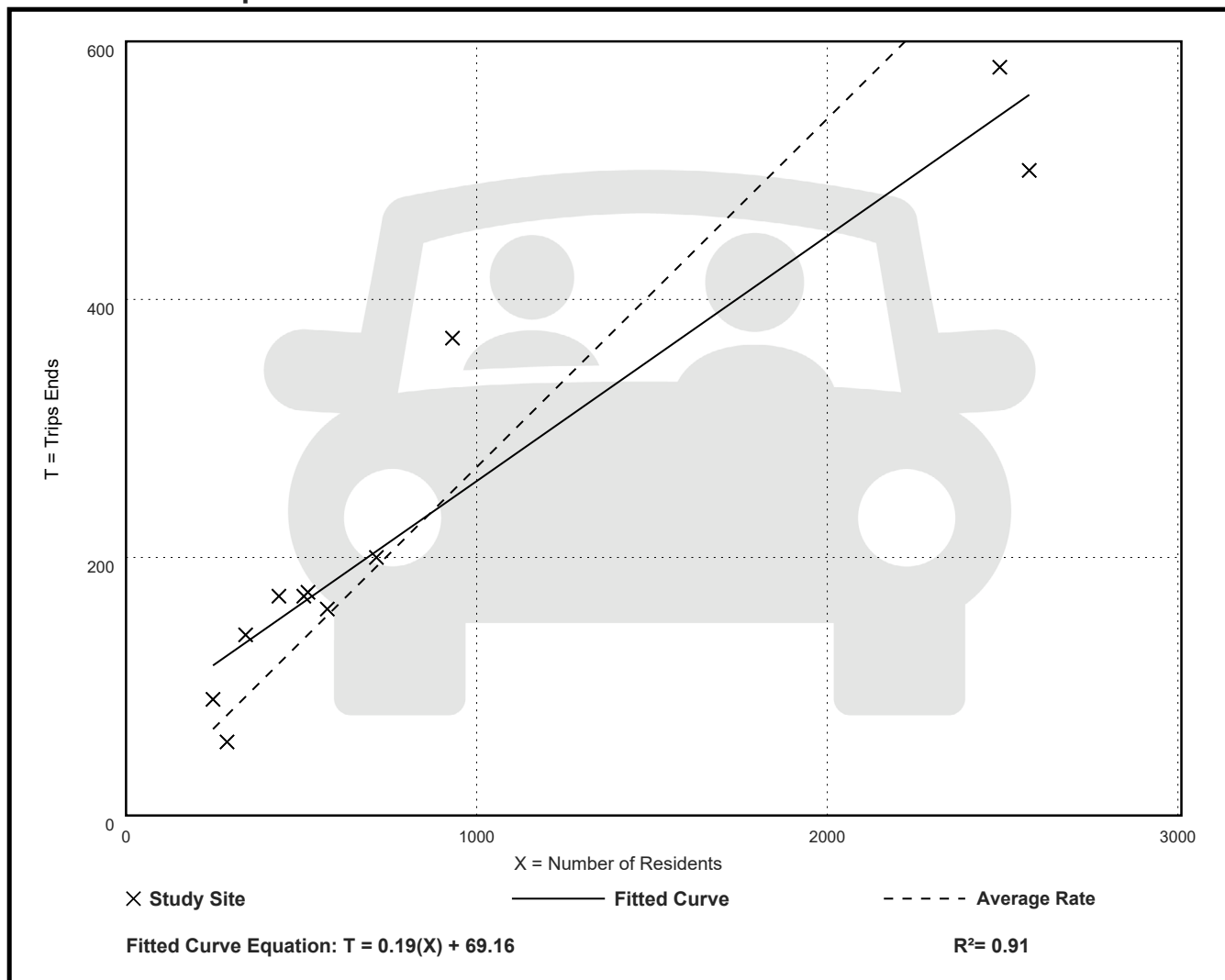

Single-Family Detached Housing (210)

Vehicle Trip Ends vs: Residents
On a: Sunday

Setting/Location: General Urban/Suburban
Number of Studies: 14
Avg. Num. of Residents: 1085
Directional Distribution: 50% entering, 50% exiting

Vehicle Trip Generation per Resident

Average Rate	Range of Rates	Standard Deviation
2.42	1.62 - 3.16	0.43

Data Plot and Equation

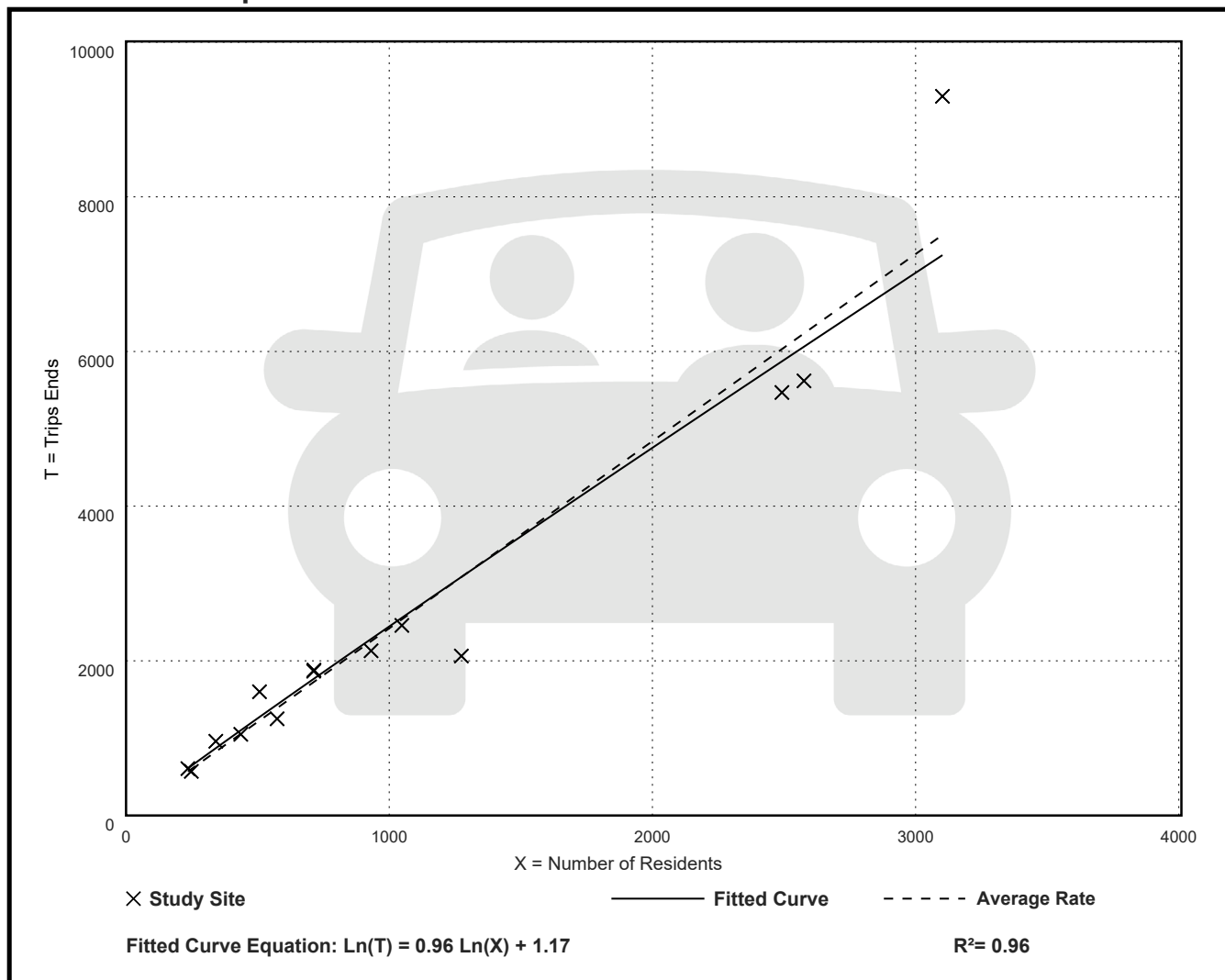

Single-Family Detached Housing (210)

Vehicle Trip Ends vs: Residents

On a: Sunday, Peak Hour of Generator

Setting/Location: General Urban/Suburban

Number of Studies: 12

Avg. Num. of Residents: 870

Directional Distribution: 50% entering, 50% exiting

Vehicle Trip Generation per Resident

Average Rate	Range of Rates	Standard Deviation
0.25	0.19 - 0.35	0.05

Data Plot and Equation

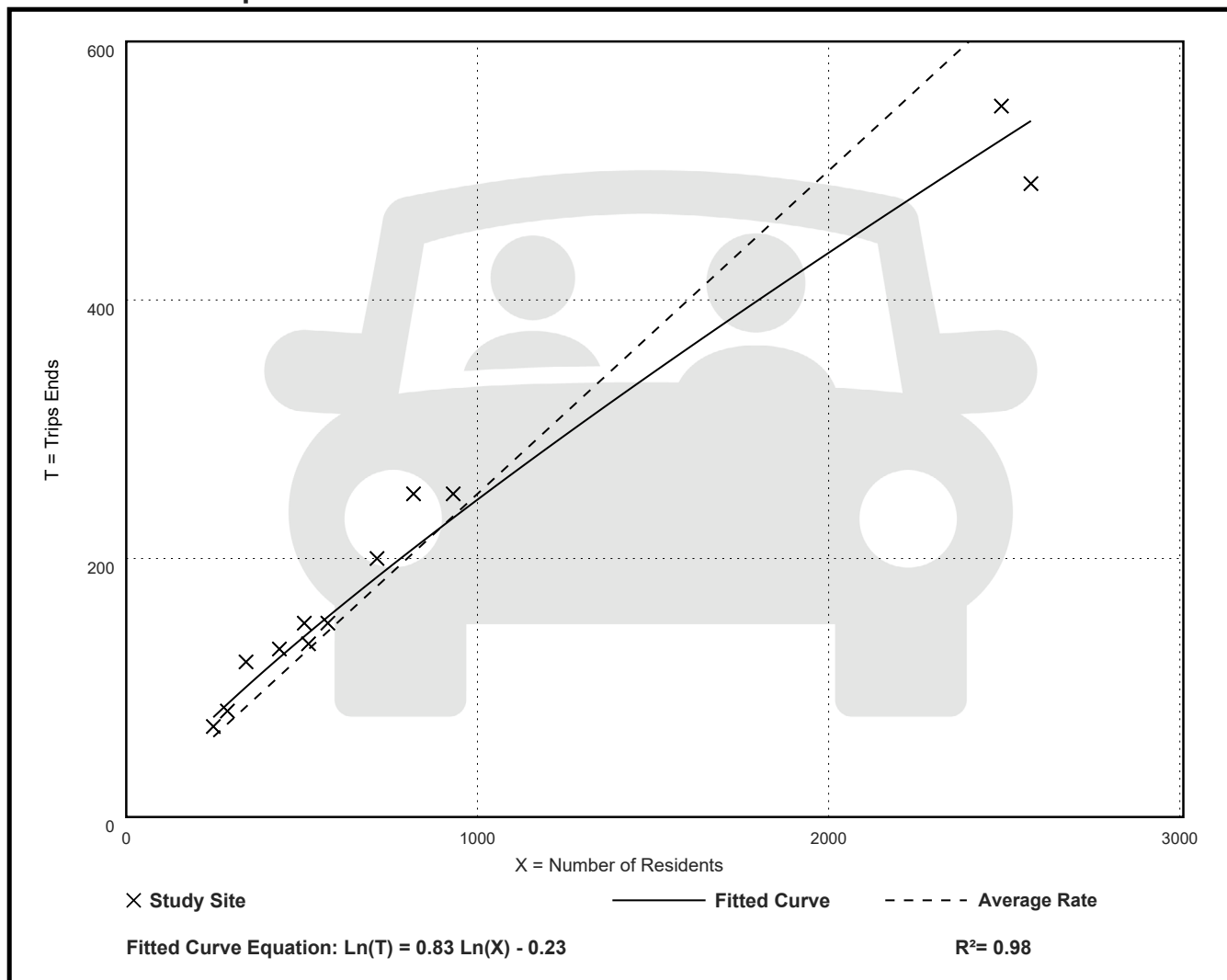

Work Request Submission Confirmation #26357235

From Eversource Do Not Reply <noreply@notifications.eversource.com>

Date Wed 5/6/2026 11:58 AM

To Paul Dimmick <pdimmick@haleyward.com>

You don't often get email from noreply@notifications.eversource.com. [Learn why this is important](#)



EVERSOURCE

Work Request
Submission
Confirmation

Work Request Type:
Customer Requested
Work (Private)

**Work Request
Number:**
26357235

Job Location:
20 CENTRAL AVENUE

Dear Valued Customer,

We received your work request with the following information:

- * Request Type: Customer Requested Work (Private)
- * Request Number: 26357235
- * Work Requested Date: 2026-05-06
- * Job Location: 20 CENTRAL AVENUE
- * Contractor Name: PAUL DIMMICK
- * Contractor Phone Number: 6034309282

NOTE: This email confirms we received your request and does not imply that work will be performed.

Log into your Eversource.com account to track the status of your request. For questions or to cancel your request, call or email us and we'll be happy to assist you.

Sincerely,
Eversource Electric Service Support Center.
18003627764
NHNewService@eversource.com

Please save this confirmation email for your records.
This is an unmonitored mailbox - please do not reply.



May 6, 2026

Paul Dimmick
Haley Ward
200 Griffin Rd Unit 14
Portsmouth NH 03801

RE: Natural Gas Availability to 20 Central Ave Portsmouth NH

Dear Paul,

Unitil's natural gas division has reviewed the requested site for natural gas service.

Unitil hereby confirms natural gas service will be available to 20 Central Ave, Portsmouth NH to serve a three unit residential project. Our closest natural gas main is on Maplewood Ave, roughly 550' away.

Installation is pending the receipt of natural gas load information, an installation agreement with the owner and a street opening approval from the City of Portsmouth DPW.

Let me know if you have any questions. You can email me at oliver@unitil.com. My phone number is 603-294-5174.

Sincerely,

Janet Oliver
Senior Business Development Representative

“GREEN” BUILDING STATEMENT, 20 CENTRAL AVENUE, PORTSMOUTH, NH

LOCATION AND TRANSPORTATION

Walkable Destinations: 20 Central Avenue is located adjoining Maplewood Avenue. It is walkable to downtown Portsmouth.

Bicycles: This is a bike friendly part of the city.

Ride sharing: Although this location is not serviced directly by public transportation, there are numerous bus stops along Maplewood Avenue. The address also allows easy access and is a quickly identifiable for cabs or shared transportation services.

SITE

Stormwater: The existing site has stormwater collection that services the neighborhood. Runoff currently sheet flows from north of the site to the southeast to a catch basin. The proposed development will include an increase in stormwater controls to manage the increase of impervious cover from the proposed development. The proposed stormwater design will include the installation of two rain gardens with new orifices leading to the existing stormwater drains that serve as stormwater control for the neighborhood.

Reuse: The existing site is a single-family home. The proposed project will redevelop the site with three single-family homes that is more cohesive with the surrounding residential developments.

Landscaping: A professionally produced landscaping plan includes shrubbery, grass, and a multitude of trees that currently do not exist. An irrigation system to maintain grass and plantings is included.

Zoning: This project is in the GRA zone.

UTILITIES AND FIRE PROTECTION

Water: New water-saving plumbing fixtures will be installed as per the current plumbing code.

Sewer: Tying into public sewer in Central Avenue and Beechwood Street.

Electric: Tying into existing overhead lines on Central Avenue and Beechwood Street.

Gas or heating oil: Heating oil will be provided.

ENERGY:

Heating and Air Conditioning:

System: Forced Hot Air with Central A/C.

Furnace: Gas fired, Rheem or similar.

Zones: 3 zones; first and second floor, to be determined by plan. Additional zones available as an upgrade.

Insulation: ENERGY STAR Certified

Ceiling: R-49 fiberglass or R-30 in slopes, Upgrades available.

Exterior Walls: "Flash and Batt" 2" spray foam polyurethane insulation w/3.5" R-13 fiberglass, R32 +/-.

Basement: R-30 fiberglass in ceiling.

Garage Ceiling: R-30 fiberglass with conditioned space above only.

Lighting: LED lighting will be used throughout.

Kitchen Appliances: All kitchen appliances will be energy-star certified.

Fenestration: Windows and doors that are state-of-the-art and shall have a U-value below .30, meeting or exceeding energy-star requirements. Proposed windows are to exceed Energy Star 7 window requirements for this region.

Please note that the building energy information provided above is preliminary and subject to change prior to final Planning Board approval.

5/14/2026

Opal Marquise Classic with Wing, 30x28

370.127.v5 GR (5/14/2026)

©2011 Art Form Architecture, LLC, all rights reserved. You may not build this design without purchasing a license, even if you make changes. This design may have geographic restrictions.



Art Form Architecture, LLC

603-431-9559



©2011 Art Form Architecture, LLC
Opal Marquise Classic with Wing, 30x28 370.127.v5 GR

Dear Builders and Home Buyers,

In addition to our Terms and Conditions (the "Terms"), please be aware of the following:

This design may not yet have Construction Drawings (as defined in the Terms), and is, therefore, only available as a Design Drawing (as defined in the Terms and together with Construction Drawings, "Drawings"). It is possible that during the conversion of a Design Drawing to a final Construction Drawing, changes may be necessary including, but not limited to, dimensional changes. Please see Plan Data Explained on www.artform.us to understand room sizes, dimensions and other data provided. We are not responsible for typographical errors.

Art Form Architecture ("Art Form") requires that our home designs be built substantially as designed. Art Form will not be obligated by or liable for use of this design with markups as part of any builder agreement. While we attempt to accommodate where possible and reasonable, and where the changes do not denigrate our design, any and all changes to Drawings must be approved in writing by Art Form. It is recommended that you have your Drawing updated by Art Form prior to attaching any Drawing to any builder agreement. Art Form shall not be responsible for the misuse of or unauthorized alterations to any of its Drawings.

Facade Changes:

- To maintain design integrity, we pay particular attention to features on the front facade, including but not limited to door surrounds, window casings, finished porch column sizes, and roof friezes. While we may allow builders to add their own flare to aesthetic elements, we don't allow our designs to be stripped of critical details. Any such alterations require the express written consent of Art Form.
- Increasing ceiling heights usually requires adjustments to window sizes and other exterior elements.

Floor plan layout and/or Structural Changes:

- Structural changes always require the express written consent of Art Form
- If you wish to move or remove walls or structural elements (such as removal of posts, increases in house size, ceiling height changes, addition of dormers, etc), please do not assume it can be done without other additional changes (even if the builder or lumber yard says you can).

5/14/2026

Opal Marquise Classic with Wing, 30x28

370.127.v5 GR (5/14/2026)

©2011 Art Form Architecture, LLC, all rights reserved. You may not build this design without purchasing a license, even if you make changes. This design may have geographic restrictions.



Art Form Architecture, LLC

603-431-9559



©2011 Art Form Architecture, LLC
Opal Marquise Classic with Wing, 30x28 370.127.v5 GR

5/14/2026

Opal Marquise Classic with Wing, 30x28

370.127.v5 GR (5/14/2026)

©2011 Art Form Architecture, LLC, all rights reserved. You may not build this design without purchasing a license, even if you make changes. This design may have geographic restrictions.



Art Form Architecture, LLC

603-431-9559

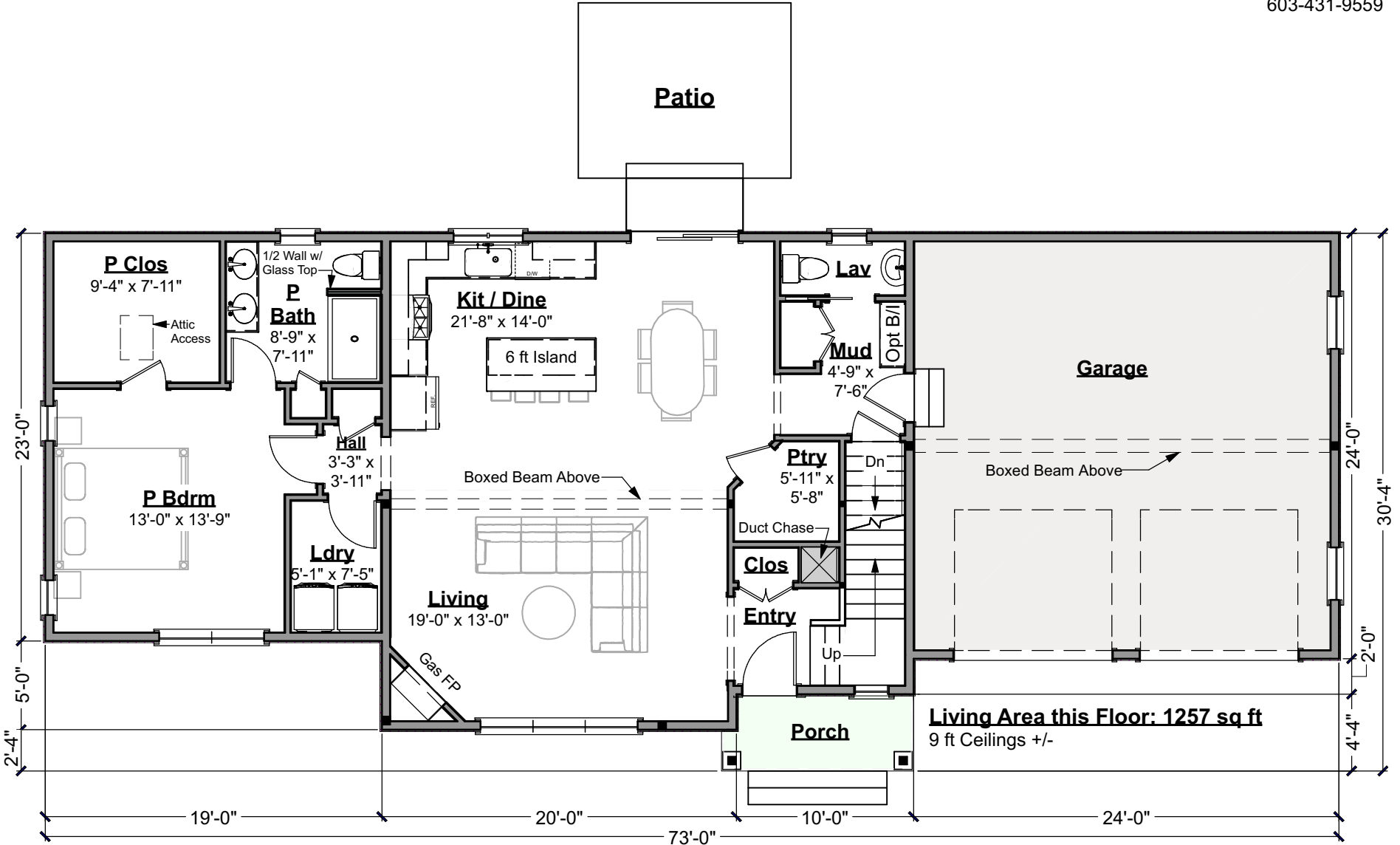

First Floor Plan

Scale: 1/8" = 1'-0"

5/14/2026

Opal Marquise Classic with Wing, 30x28

370.127.v5 GR (5/14/2026)

©2011 Art Form Architecture, LLC, all rights reserved. You may not build this design without purchasing a license, even if you make changes. This design may have geographic restrictions.



Art Form Architecture, LLC

603-431-9559

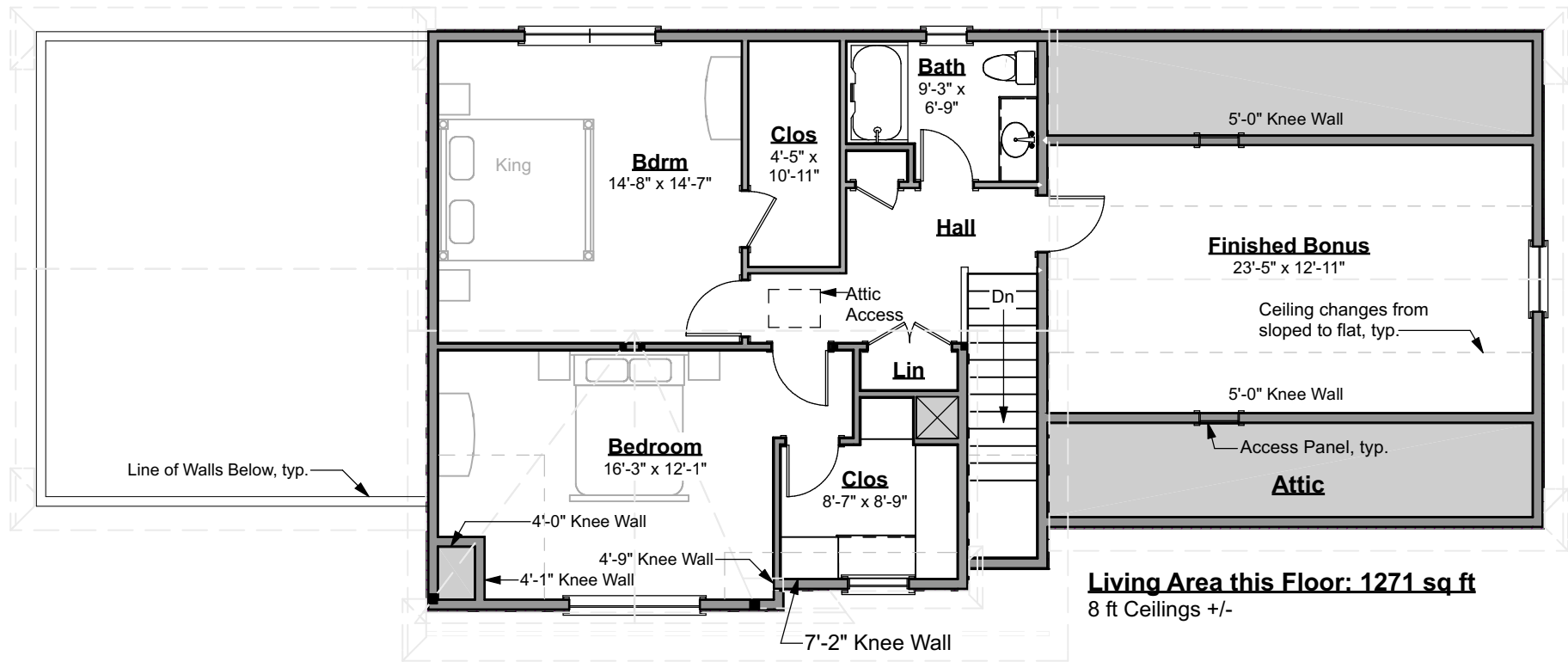

Living Area this Floor: 1271 sq ft
8 ft Ceilings +/-

Second Floor Plan

Scale: 1/8" = 1'-0"

5/14/2026
Opal Marquise Classic with Wing, 30x28
370.127.v5 GR (5/14/2026)

©2011 Art Form Architecture, LLC, all rights reserved. You may not build this design without purchasing a license, even if you make changes. This design may have geographic restrictions.



Art Form Architecture, LLC

603-431-9559

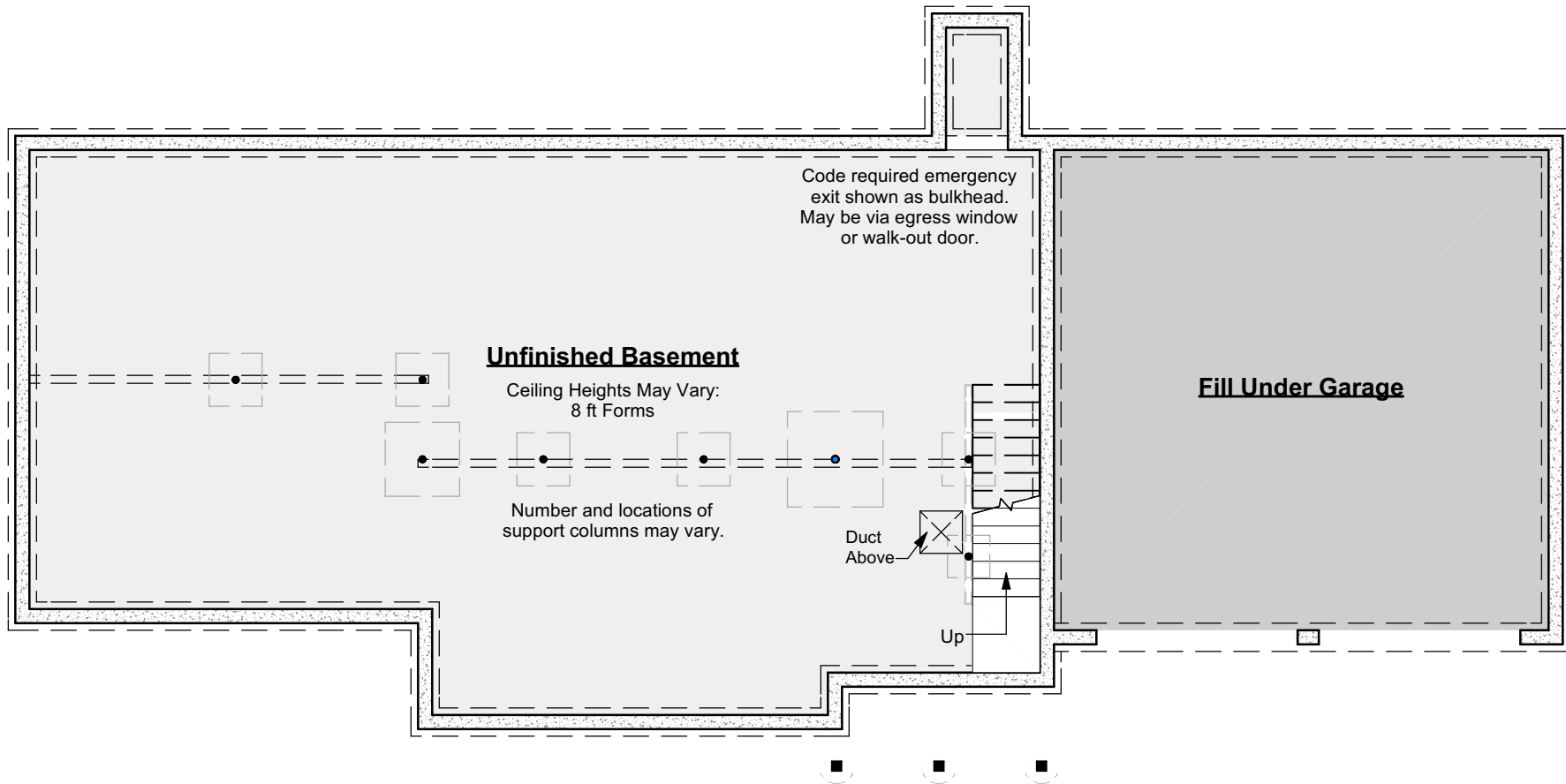

Foundation Plan
Scale: 1/8" = 1'-0"

5/14/2026
Opal Marquise Classic with Wing, 30x28
370.127.v5 GR (5/14/2026)

©2011 Art Form Architecture, LLC, all rights reserved. You may not build this design without purchasing a license, even if you make changes. This design may have geographic restrictions.



Art Form Architecture, LLC

603-431-9559



Front Elevation
Scale: 1/8" = 1'-0"

5/14/2026
Opal Marquise Classic with Wing, 30x28
370.127.v5 GR (5/14/2026)

©2011 Art Form Architecture, LLC, all rights reserved. You may not build this design without purchasing a license, even if you make changes. This design may have geographic restrictions.



Art Form Architecture, LLC

603-431-9559



Right Elevation
Scale: 1/8" = 1'-0"

5/14/2026
Opal Marquise Classic with Wing, 30x28
370.127.v5 GR (5/14/2026)

©2011 Art Form Architecture, LLC, all rights reserved. You may not build this design without purchasing a license, even if you make changes. This design may have geographic restrictions.



Art Form Architecture, LLC

603-431-9559



Rear Elevation
Scale: 1/8" = 1'-0"

5/14/2026
Opal Marquise Classic with Wing, 30x28
370.127.v5 GR (5/14/2026)

©2011 Art Form Architecture, LLC, all rights reserved. You may not build this design without purchasing a license, even if you make changes. This design may have geographic restrictions.



Art Form Architecture, LLC

603-431-9559



Left Elevation
Scale: 1/8" = 1'-0"



Art Form Architecture, LLC

SHERLOCK

387.124.v25 GR

In addition to our Terms and Conditions (the "Terms"), please be aware of the following:

Art Form Architecture, LLC ("Artform") requires that our Drawings be built substantially as designed. Artform will not be obligated by or liable for use of this design with markups as part of any builder agreement. While we attempt to accommodate where possible and reasonable, and where the changes do not denigrate our design, any and all changes to Drawings must be approved in writing by Artform. It is recommended that you have your Drawing updated by Artform prior to attaching any Drawing to any builder agreement. Artform shall not be responsible for the misuse of or unauthorized alterations to any of its Drawings.



Width 48.00 ^{FT}

Depth 36.00 ^{FT}

Height 33.16 ^{FT}

LIVING AREA		BEDROOMS		BATHROOMS	
	2446 ^{FT}		4		2.5
Main	2445 ^{FT}	Main	4	Main	2.5
Future	1 ^{FT}	Future	0	Future	0
2 nd Unit	0 ^{FT}	2 nd Unit	0	2 nd Unit	0



Art Form Architecture, LLC

SHERLOCK - REAR RENDER

387.124.v25 GR

Some features shown are optional. Your Purchase & Sale Agreement governs, whether items are labeled "optional" in this document or not.





Art Form Architecture, LLC

SHERLOCK - 1ST FLOOR

387.124.v25 GR

Some features shown are optional. Your Purchase & Sale Agreement governs, whether items are labeled "optional" in this document or not.

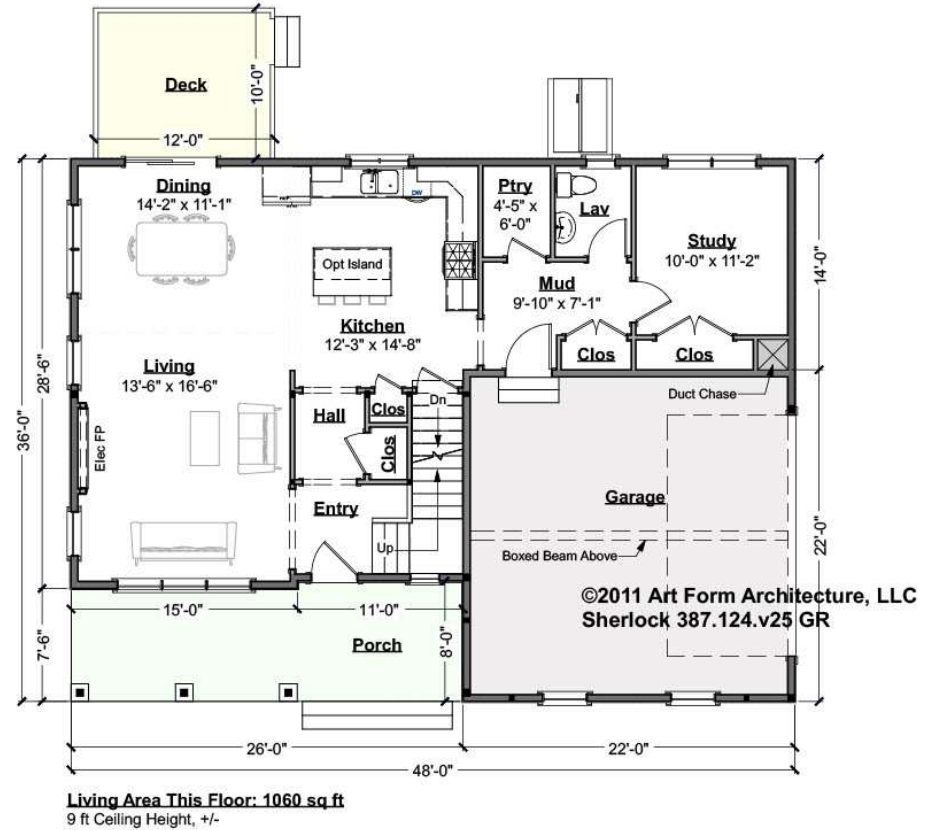

CLG HT SHOWN 9'-0" CLG HT POSSIBLE 8'-0"

* Major Change Fee, see website plan page for cost

F1 LIVING AREA		F1 BEDROOMS		F1 BATHROOMS	
	1061 FT		0		0.5
Main	1060.00 FT	Main		Main	0.50
Future	1.00 FT	Future		Future	
2 nd Unit	FT	2 nd Unit		2 nd Unit	



SHERLOCK - 2ND FLOOR
387.124.v25 GR

Some features shown are optional. Your Purchase & Sale Agreement governs, whether items are labeled "optional" in this document or not.

©2011 Art Form Architecture, LLC
 Sherlock 387.124.v25 GR

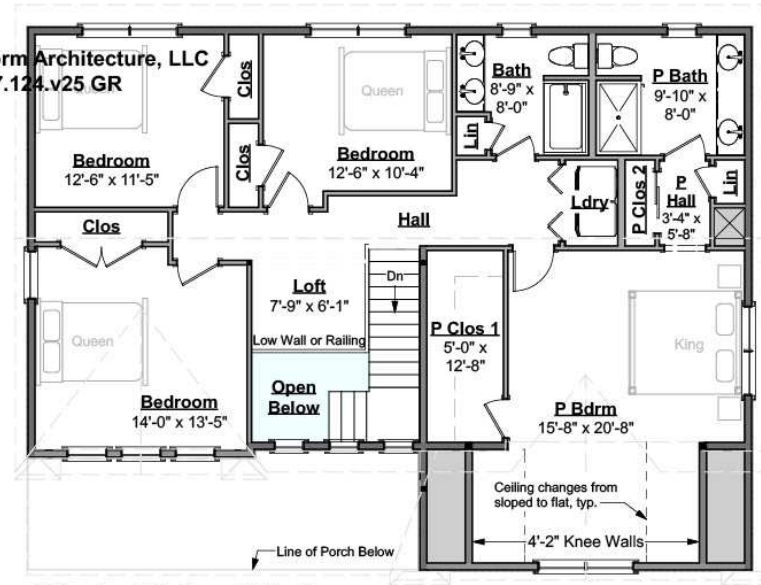

Living Area This Floor: 1385 sq ft
 8 ft Ceiling Height, +/-

CLG HT SHOWN 8'-0"

CLG HT POSSIBLE 9'-0"

** Major Change Fee, see website plan page for cost*

F1 LIVING AREA		F1 BEDROOMS		F1 BATHROOMS	
	1385 ^{FT}		4		2
Main	1385.00 ^{FT}	Main	4.00	Main	2.00
Future	FT	Future		Future	
2 nd Unit	FT	2 nd Unit		2 nd Unit	



SHERLOCK - BASEMENT

387.124.v25 GR

Some features shown are optional. Your Purchase & Sale Agreement governs, whether items are labeled "optional" in this document or not.

©2011 Art Form Architecture, LLC
 Sherlock 387.124.v25 GR

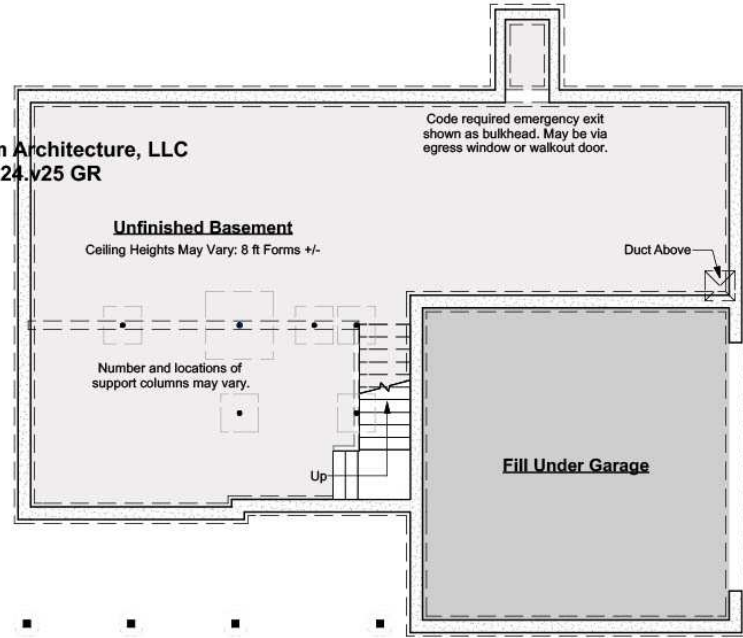

CLG HT SHOWN 7'-8" CLG HT POSSIBLE 10' & Up

* Major Change Fee, see website plan page for cost

F1 LIVING AREA		F1 BEDROOMS		F1 BATHROOMS	
	0 FT		0		0
Main	FT	Main		Main	
Future	FT	Future		Future	
2 nd Unit	FT	2 nd Unit		2 nd Unit	



Art Form Architecture, LLC

SHERLOCK - FRONT ELEVATION

387.124.v25 GR

Some features shown are optional. Your Purchase & Sale Agreement governs, whether items are labeled "optional" in this document or not.





Art Form Architecture, LLC

SHERLOCK - RIGHT ELEVATION

387.124.v25 GR

Some features shown are optional. Your Purchase & Sale Agreement governs, whether items are labeled "optional" in this document or not.





Art Form Architecture, LLC

SHERLOCK - REAR ELEVATION

387.124.v25 GR

Some features shown are optional. Your Purchase & Sale Agreement governs, whether items are labeled "optional" in this document or not.





Art Form Architecture, LLC

SHERLOCK - LEFT ELEVATION

387.124.v25 GR

Some features shown are optional. Your Purchase & Sale Agreement governs, whether items are labeled "optional" in this document or not.

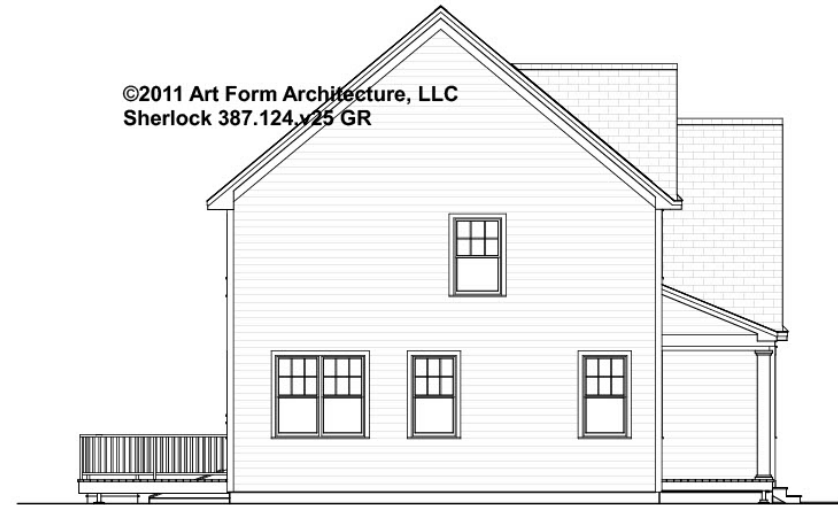



HALEY WARD®

STORMWATER MANAGEMENT AND EROSION CONTROL PLAN

**TO THE CITY OF PORTSMOUTH
FOR 20 CENTRAL AVENUE**

Map 209, Lot 30 | Portsmouth, NH

APPLICANT:

Copley Properties, LLC

94 Portsmouth Avenue, Stratham, NH 03885



June 22, 2026
JN: 5010658.001

REPORT PREPARED BY:

Haley Ward, Inc.

200 Griffin Road, Unit 14 | Portsmouth, NH 03801



EXECUTIVE SUMMARY

This drainage analysis examines the pre-development (existing) and post-development (proposed) stormwater drainage patterns for the proposed residential redevelopment project at 20 Central Avenue in Portsmouth, NH. The site is shown on the City of Portsmouth Assessor's Tax Map 209 as Lot 30. The total size of the existing lot is approximately 28,972 square feet.

The development will subdivide the existing lot and provide for the construction of three (3) single-family homes, with associated landscaping, utilities, and driveways. The new buildings will be serviced by public water and sewer. The development has the potential to increase stormwater runoff to adjacent properties and therefore must be designed in a manner to prevent that occurrence. This will be done primarily by capturing stormwater runoff and routing it through appropriate stormwater facilities, designed to ensure that there will be no significant increase in peak runoff from the site as a result of this project.

The intent of this stormwater design is to comply with the requirements of Section 7.6.1.4 of the City of Portsmouth Site Plan Review Ordinance as related to post-development peak rate of runoff reduction and to improve the overall stormwater system as part of the redevelopment.

INTRODUCTION / PROJECT DESCRIPTION

This drainage report is designed to assist the owner, planning board, contractor, regulatory reviewer, and others in understanding the impact of the proposed development project on local surface water runoff. Bounding the site to the north and east are developed residential properties. The site is bound to the south and west by Central Avenue and Beechwood Street, respectively.

The proposed development will include the construction of single-family homes, decks, driveways, and walkways causing an increase in impervious cover. To offset the increase, two rain gardens have been designed for Proposed Lot 2 and 3. The rain gardens will collect roof runoff from either drip strips or gutters with downspouts. The rain gardens will be equipped with a beehive grate to guide flow for filtration into the existing stormwater systems. The site layouts and drainage designs are preliminary and intended for planning purposes only to show compliance with the zoning ordinances.

The applicant shall submit final site/stormwater design plans with an Operations and Maintenance Plan for review and approval as part of the Building Permit application.

This report includes information about the existing site necessary to analyze stormwater runoff. The report includes maps of pre- development and post-development



watersheds, subcatchment areas and calculations of runoff. The report provides a narrative of the stormwater runoff and describes numerically and graphically the surface water runoff patterns for this site. Proposed stormwater structures and methods will also be described, as well as erosion and sediment control practices. Included within the submittal is an Inspection and Long-Term Maintenance Plan for the proposed project. To fully understand the proposed site development the reader should also review the complete site plan set in addition to this report.

METHODOLOGY

“Extreme Precipitation” values from The Northeast Regional Climate Center (Cornell University) have been used for modeling purposes. These values have been used in this analysis, with a 15% addition to comply with local ordinances.

This report uses the US Soil Conservation Service (SCS) Method for estimating stormwater runoff. The SCS method is published in The National Engineering Handbook (NEH), Section 4 “Hydrology” and includes the Technical Release No. 20, (TR-20) “Computer Program for Project Formulation Hydrology”, and Technical Release No. 55 (TR-55) “Urban Hydrology for Small Watersheds” methods. This report uses the HydroCAD version 10.20 program, written by HydroCAD Software Solutions LLC, Chocorua, N.H., to apply these methods for the calculation of runoff and for pond modeling. Rainfall data and runoff curve numbers are taken from “The Stormwater Management and Erosion Control Handbook for Urban and Developing Areas in New Hampshire.”

Time of Concentration (T_c) is calculated by entering measured flow path data such as flow path type, length, slope and surface characteristics into the HydroCAD program. For the purposes of this report, a minimum time of concentration of 5 minutes is used.

The storm events used for the calculations in this report are the 2-year, 10-year, 25-year, and 50-year (24-hour) storms. Watershed basin boundaries have been delineated using topographic maps prepared by Haley Ward and field observations to confirm.



SITE SPECIFIC INFORMATION

Based on the United States Department of Agriculture (USDA) Natural Resources Conservation Service (NRCS), Soil Survey of Rockingham County, New Hampshire the site is made up of one soil type:

Soil Symbol	Soil Name and Slopes
799	Urban land-Canton complex (3-15% slopes)

A "Type B" hydrologic rating was assumed for the stormwater modelling.

The physical characteristics of the existing lot consist of slopes from 3 to 15%, with the lot generally sloping down from Northwest to Southeast towards Beechwood Street. Elevations on the site range from 14 to 24 feet above mean sea level. The surrounding stormwater collects in the two (2) existing stormdrain easements, located on the southerly portion of the property and flowing west to east.

According to the Federal Emergency Management Agency (FEMA) Flood Insurance Rate Map, Panel 33015C0259F, the project site is not in a special flood hazard area.

There are no protected natural resources on or directly adjacent to the subject property.

PRE-DEVELOPMENT DRAINAGE

In the pre-development condition, the site has been analyzed as two (2) subcatchment watershed basins based on localized topography and discharge location. A Pre-Development Hydrology map and HydroCAD model results have been provided.

Subcatchment 1 represents majority of the flow and the undeveloped grass area of the site. The flow area is generally from northwest to southeast with the northerly abutting area draining onto the site and the flow connecting into the existing catch basin, a part of the City's stormwater system and noted as Summation Point 1 (SP1). SP1 represents the southerly easement that exists along the southern boundary of the lot, generally flowing west to east.

Subcatchment 2 represents the southwest area, including majority of the existing dwelling on site. The flow area leads south onto Beechwood Street and is collected in the City's stormwater system, denoted as Summation Point 2 (SP2). SP2 represents the northerly easement that exists along the southern boundary of the lot that runs parallel with SP1.



POST-DEVELOPMENT DRAINAGE

The proposed development has been designed to match the pre-development drainage patterns to the greatest extent feasible. In the post-development condition, the site has been analyzed as two (2) subcatchment basins. A Post-Development Hydrology map and HydroCAD model results have been provided.

Subcatchment 1A continues to represent the stormwater flow from the northerly abutting properties.

Subcatchment 1B represents the proposed swale along the northerly boundary of the property and culvert leading to the catch basin within Proposed Lot 3.

Subcatchment 1C represents the proposed grass area between dwellings and draining to a rain garden connected to the existing catch basin within Proposed Lot 3.

Subcatchments 1D, 1E, and 1F represent the roof runoff from the proposed drip trench collection systems along the abutting edge of each property.

Subcatchment 2A continues to represent the reduced western half of the site which drains into a rain garden and directly into the northerly stormwater easement.

Subcatchment 2B represents the flow generally from the proposed driveway and southerly grassed area of Lot 2, leading to Beechwood Street and into the City's stormwater system.

RUNOFF COMPARISON

Table 1: Pre-Development to Post-Development Comparison

Design Point	Q2 (CFS)		Q10 (CFS)		Q25 (CFS)		Q50 (CFS)		Description
	Pre	Post	Pre	Post	Pre	Post	Pre	Post	
SP1	0.67	0.54	2.06	1.96	3.34	3.20	4.66	4.47	Southern Stormwater System
SP2	0.22	0.04	0.55	0.47	0.84	0.76	1.14	1.01	Northern Stormwater System

As shown in Table 1, post-development runoff rates are similar or less than those observed under pre-development conditions.

EROSION AND SEDIMENT CONTROL PRACTICES

During construction, the potential for erosion exists due to stormwater runoff. The



contractor will be required to inspect and maintain all necessary erosion control measures, as well as installing any additional measures as required. All erosion control practices shall conform to "The Stormwater Management and Erosion Control Handbook for Urban and Developing Areas in New Hampshire." Some examples of erosion and sediment control measures to be utilized for this project during construction may include:

- Silt Soxx (or approved alternative) located at the toe of disturbed slopes
- Stabilized construction entrance at access point to the site
- Temporary mulching and seeding for disturbed areas
- Spraying water over disturbed areas to minimize wind erosion

After construction, permanent stabilization will be accomplished by permanent seeding, landscaping, and surfacing the access drives and parking areas with asphalt paving and other areas with impervious walkways.

CONCLUSION

The proposed development has been designed to match the pre-development drainage patterns to the greatest extent feasible. With the design of the rain gardens connecting to the existing stormwater systems, the post-development runoff rates are effectively equivalent to the pre-development runoff rates. Erosion and sediment control practices will be implemented for both the temporary condition during construction and for final stabilization after construction. Therefore, there are no negative impacts to downstream receptors or adjacent properties anticipated as a result of this project.

REFERENCES

1. UNH Stormwater Center, Comprehensive Environmental Inc., and NH Department of Environmental Services, "NH Stormwater Manual 2025" (2025). *UNH Stormwater Center*. 126.
2. Minnick, E.L. and H.T. Marshall. *Stormwater Management and Erosion and Sediment Control Handbook for Urban and Developing Areas in New Hampshire*, prepared by Rockingham County Conservation District, prepared for New Hampshire Department of Environmental Services, in cooperation with USDA Soil Conservation Service, August 1992.
3. HydroCAD Software Solution, LLC. *HydroCAD Stormwater Modeling System Version 10.20-9a* copyright 2026.

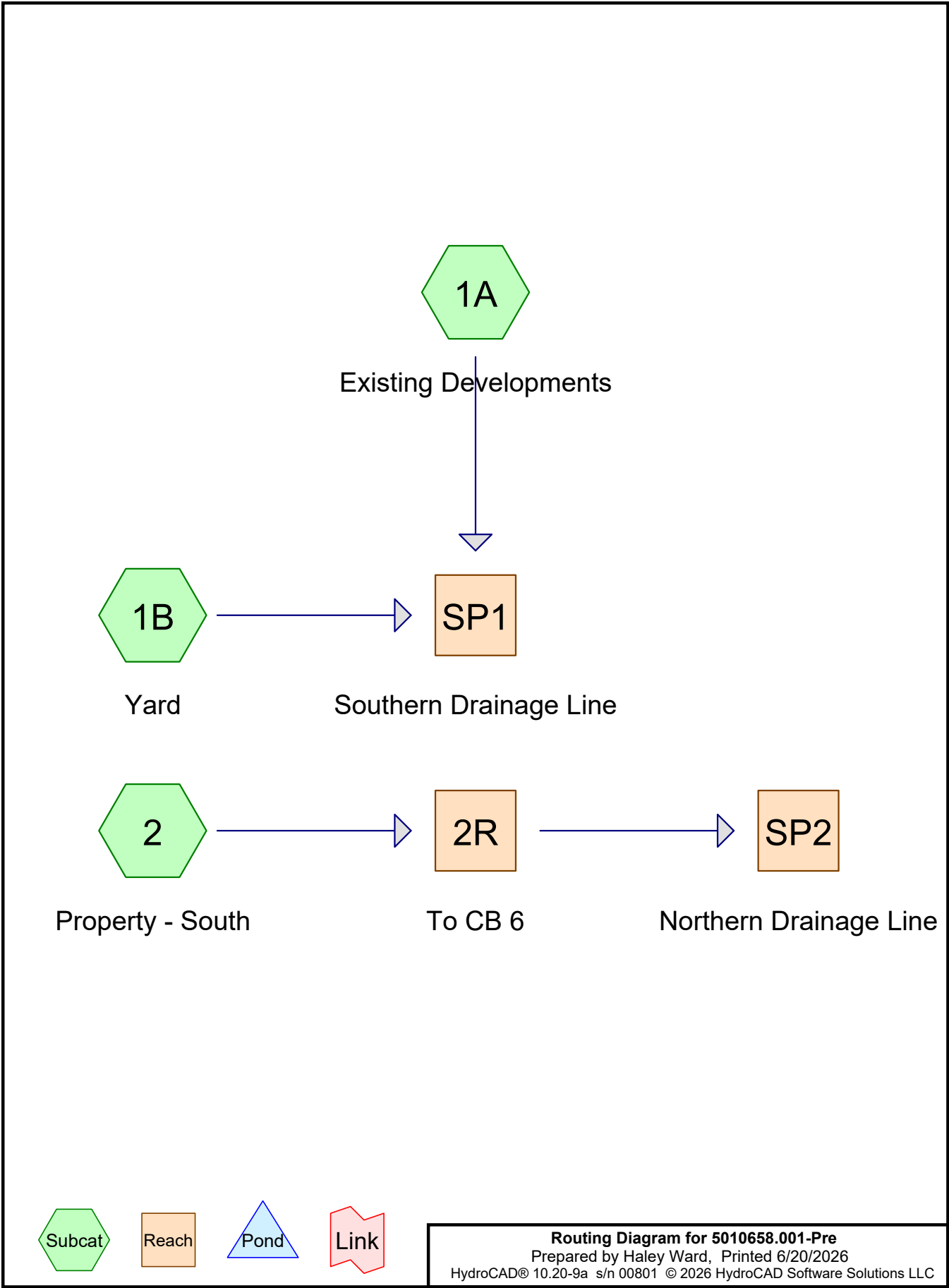

Area Listing (all nodes)

Area (sq-ft)	CN	Description (subcatchment-numbers)
48,695	61	>75% Grass cover, Good, HSG B (1A, 1B, 2)
525	48	Brush, Good, HSG B (2)
475	98	Paved parking, HSG B (2)
1,560	98	Roofs, HSG B (1B, 2)
2,130	98	Unconnected pavement, HSG B (1A, 1B, 2)
53,385	64	TOTAL AREA

Soil Listing (all nodes)

Area (sq-ft)	Soil Group	Subcatchment Numbers
0	HSG A	
53,385	HSG B	1A, 1B, 2
0	HSG C	
0	HSG D	
0	Other	
53,385		TOTAL AREA

Time span=0.00-24.00 hrs, dt=0.05 hrs, 481 points
Runoff by SCS TR-20 method, UH=SCS, Weighted-CN
Reach routing by Stor-Ind+Trans method - Pond routing by Stor-Ind method

Subcatchment 1A: Existing Developments Runoff Area=20,770 sf 1.64% Impervious Runoff Depth>0.65"
Tc=5.0 min UI Adjusted CN=61 Runoff=0.28 cfs 1,133 cf

Subcatchment 1B: Yard Runoff Area=23,250 sf 8.39% Impervious Runoff Depth>0.75"
Tc=5.0 min UI Adjusted CN=63 Runoff=0.39 cfs 1,450 cf

Subcatchment 2: Property - South Runoff Area=9,365 sf 20.02% Impervious Runoff Depth>0.95"
Tc=5.0 min UI Adjusted CN=67 Runoff=0.22 cfs 743 cf

Reach 2R: To CB 6 Avg. Flow Depth=0.01' Max Vel=1.48 fps Inflow=0.22 cfs 743 cf
n=0.013 L=25.0' S=0.1600 '/' Capacity=118.38 cfs Outflow=0.22 cfs 743 cf

Reach SP1: Southern Drainage Line Inflow=0.67 cfs 2,583 cf
Outflow=0.67 cfs 2,583 cf

Reach SP2: Northern Drainage Line Inflow=0.22 cfs 743 cf
Outflow=0.22 cfs 743 cf

Total Runoff Area = 53,385 sf Runoff Volume = 3,326 cf Average Runoff Depth = 0.75"
92.20% Pervious = 49,220 sf 7.80% Impervious = 4,165 sf

Time span=0.00-24.00 hrs, dt=0.05 hrs, 481 points
Runoff by SCS TR-20 method, UH=SCS, Weighted-CN
Reach routing by Stor-Ind+Trans method - Pond routing by Stor-Ind method

Subcatchment 1A: Existing Developments Runoff Area=20,770 sf 1.64% Impervious Runoff Depth>1.73"
Tc=5.0 min UI Adjusted CN=61 Runoff=0.92 cfs 3,003 cf

Subcatchment 1B: Yard Runoff Area=23,250 sf 8.39% Impervious Runoff Depth>1.89"
Tc=5.0 min UI Adjusted CN=63 Runoff=1.14 cfs 3,668 cf

Subcatchment 2: Property - South Runoff Area=9,365 sf 20.02% Impervious Runoff Depth>2.22"
Tc=5.0 min UI Adjusted CN=67 Runoff=0.55 cfs 1,735 cf

Reach 2R: To CB 6 Avg. Flow Depth=0.01' Max Vel=2.11 fps Inflow=0.55 cfs 1,735 cf
n=0.013 L=25.0' S=0.1600 '/' Capacity=118.38 cfs Outflow=0.55 cfs 1,735 cf

Reach SP1: Southern Drainage Line Inflow=2.06 cfs 6,671 cf
Outflow=2.06 cfs 6,671 cf

Reach SP2: Northern Drainage Line Inflow=0.55 cfs 1,735 cf
Outflow=0.55 cfs 1,735 cf

Total Runoff Area = 53,385 sf Runoff Volume = 8,406 cf Average Runoff Depth = 1.89"
92.20% Pervious = 49,220 sf 7.80% Impervious = 4,165 sf

Summary for Subcatchment 1A: Existing Developments

Runoff = 0.92 cfs @ 12.09 hrs, Volume= 3,003 cf, Depth> 1.73"
 Routed to Reach SP1 : Southern Drainage Line

Runoff by SCS TR-20 method, UH=SCS, Weighted-CN, Time Span= 0.00-24.00 hrs, dt= 0.05 hrs
 Type III 24-hr 10-Yr Rainfall=5.59"

Area (sf)	CN	Adj	Description
340	98		Unconnected pavement, HSG B
20,430	61		>75% Grass cover, Good, HSG B
20,770	62	61	Weighted Average, UI Adjusted
20,430			98.36% Pervious Area
340			1.64% Impervious Area
340			100.00% Unconnected

Tc (min)	Length (feet)	Slope (ft/ft)	Velocity (ft/sec)	Capacity (cfs)	Description
5.0					Direct Entry,

Summary for Subcatchment 1B: Yard

Runoff = 1.14 cfs @ 12.09 hrs, Volume= 3,668 cf, Depth> 1.89"
 Routed to Reach SP1 : Southern Drainage Line

Runoff by SCS TR-20 method, UH=SCS, Weighted-CN, Time Span= 0.00-24.00 hrs, dt= 0.05 hrs
 Type III 24-hr 10-Yr Rainfall=5.59"

Area (sf)	CN	Adj	Description
21,300	61		>75% Grass cover, Good, HSG B
1,580	98		Unconnected pavement, HSG B
370	98		Roofs, HSG B
23,250	64	63	Weighted Average, UI Adjusted
21,300			91.61% Pervious Area
1,950			8.39% Impervious Area
1,580			81.03% Unconnected

Tc (min)	Length (feet)	Slope (ft/ft)	Velocity (ft/sec)	Capacity (cfs)	Description
5.0					Direct Entry,

Summary for Subcatchment 2: Property - South

Runoff = 0.55 cfs @ 12.08 hrs, Volume= 1,735 cf, Depth> 2.22"
 Routed to Reach 2R : To CB 6

Runoff by SCS TR-20 method, UH=SCS, Weighted-CN, Time Span= 0.00-24.00 hrs, dt= 0.05 hrs
 Type III 24-hr 10-Yr Rainfall=5.59"

Area (sf)	CN	Adj	Description
6,965	61		>75% Grass cover, Good, HSG B
210	98		Unconnected pavement, HSG B
525	48		Brush, Good, HSG B
475	98		Paved parking, HSG B
1,190	98		Roofs, HSG B
9,365	68	67	Weighted Average, UI Adjusted
7,490			79.98% Pervious Area
1,875			20.02% Impervious Area
210			11.20% Unconnected

Tc (min)	Length (feet)	Slope (ft/ft)	Velocity (ft/sec)	Capacity (cfs)	Description
5.0					Direct Entry,

Summary for Reach 2R: To CB 6

Inflow Area = 9,365 sf, 20.02% Impervious, Inflow Depth > 2.22" for 10-Yr event
 Inflow = 0.55 cfs @ 12.08 hrs, Volume= 1,735 cf
 Outflow = 0.55 cfs @ 12.09 hrs, Volume= 1,735 cf, Atten= 1%, Lag= 0.4 min
 Routed to Reach SP2 : Northern Drainage Line

Routing by Stor-Ind+Trans method, Time Span= 0.00-24.00 hrs, dt= 0.05 hrs
 Max. Velocity= 2.11 fps, Min. Travel Time= 0.2 min
 Avg. Velocity = 0.89 fps, Avg. Travel Time= 0.5 min

Peak Storage= 7 cf @ 12.09 hrs
 Average Depth at Peak Storage= 0.01' , Surface Width= 26.04'
 Bank-Full Depth= 0.25' Flow Area= 6.6 sf, Capacity= 118.38 cfs

26.00' x 0.25' deep channel, n= 0.013 Asphalt, smooth
 Side Slope Z-value= 2.0 '/' Top Width= 27.00'
 Length= 25.0' Slope= 0.1600 '/'
 Inlet Invert= 15.15', Outlet Invert= 11.15'



Summary for Reach SP1: Southern Drainage Line

Inflow Area = 44,020 sf, 5.20% Impervious, Inflow Depth > 1.82" for 10-Yr event
 Inflow = 2.06 cfs @ 12.09 hrs, Volume= 6,671 cf
 Outflow = 2.06 cfs @ 12.09 hrs, Volume= 6,671 cf, Atten= 0%, Lag= 0.0 min

Routing by Stor-Ind+Trans method, Time Span= 0.00-24.00 hrs, dt= 0.05 hrs

Summary for Reach SP2: Northern Drainage Line

Inflow Area = 9,365 sf, 20.02% Impervious, Inflow Depth > 2.22" for 10-Yr event
Inflow = 0.55 cfs @ 12.09 hrs, Volume= 1,735 cf
Outflow = 0.55 cfs @ 12.09 hrs, Volume= 1,735 cf, Atten= 0%, Lag= 0.0 min

Routing by Stor-Ind+Trans method, Time Span= 0.00-24.00 hrs, dt= 0.05 hrs

Time span=0.00-24.00 hrs, dt=0.05 hrs, 481 points
Runoff by SCS TR-20 method, UH=SCS, Weighted-CN
Reach routing by Stor-Ind+Trans method - Pond routing by Stor-Ind method

Subcatchment 1A: Existing Developments Runoff Area=20,770 sf 1.64% Impervious Runoff Depth>2.76"
Tc=5.0 min UI Adjusted CN=61 Runoff=1.51 cfs 4,773 cf

Subcatchment 1B: Yard Runoff Area=23,250 sf 8.39% Impervious Runoff Depth>2.96"
Tc=5.0 min UI Adjusted CN=63 Runoff=1.83 cfs 5,732 cf

Subcatchment 2: Property - South Runoff Area=9,365 sf 20.02% Impervious Runoff Depth>3.37"
Tc=5.0 min UI Adjusted CN=67 Runoff=0.85 cfs 2,629 cf

Reach 2R: To CB 6 Avg. Flow Depth=0.01' Max Vel=2.51 fps Inflow=0.85 cfs 2,629 cf
n=0.013 L=25.0' S=0.1600 '/' Capacity=118.38 cfs Outflow=0.84 cfs 2,628 cf

Reach SP1: Southern Drainage Line Inflow=3.34 cfs 10,505 cf
Outflow=3.34 cfs 10,505 cf

Reach SP2: Northern Drainage Line Inflow=0.84 cfs 2,628 cf
Outflow=0.84 cfs 2,628 cf

Total Runoff Area = 53,385 sf Runoff Volume = 13,133 cf Average Runoff Depth = 2.95"
92.20% Pervious = 49,220 sf 7.80% Impervious = 4,165 sf

5010658.001-Pre

Prepared by Haley Ward

HydroCAD® 10.20-9a s/n 00801 © 2026 HydroCAD Software Solutions LLC

Type III 24-hr 50-Yr Rainfall=8.49"

Printed 6/20/2026

Page 10

Time span=0.00-24.00 hrs, dt=0.05 hrs, 481 points
Runoff by SCS TR-20 method, UH=SCS, Weighted-CN
Reach routing by Stor-Ind+Trans method - Pond routing by Stor-Ind method

Subcatchment 1A: Existing Developments Runoff Area=20,770 sf 1.64% Impervious Runoff Depth>3.82"
Tc=5.0 min UI Adjusted CN=61 Runoff=2.12 cfs 6,611 cf

Subcatchment 1B: Yard Runoff Area=23,250 sf 8.39% Impervious Runoff Depth>4.05"
Tc=5.0 min UI Adjusted CN=63 Runoff=2.53 cfs 7,856 cf

Subcatchment 2: Property - South Runoff Area=9,365 sf 20.02% Impervious Runoff Depth>4.53"
Tc=5.0 min UI Adjusted CN=67 Runoff=1.14 cfs 3,534 cf

Reach 2R: To CB 6 Avg. Flow Depth=0.02' Max Vel=2.82 fps Inflow=1.14 cfs 3,534 cf
n=0.013 L=25.0' S=0.1600 '/' Capacity=118.38 cfs Outflow=1.14 cfs 3,533 cf

Reach SP1: Southern Drainage Line Inflow=4.66 cfs 14,467 cf
Outflow=4.66 cfs 14,467 cf

Reach SP2: Northern Drainage Line Inflow=1.14 cfs 3,533 cf
Outflow=1.14 cfs 3,533 cf

Total Runoff Area = 53,385 sf Runoff Volume = 18,000 cf Average Runoff Depth = 4.05"
92.20% Pervious = 49,220 sf 7.80% Impervious = 4,165 sf

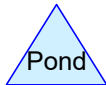
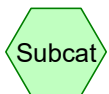
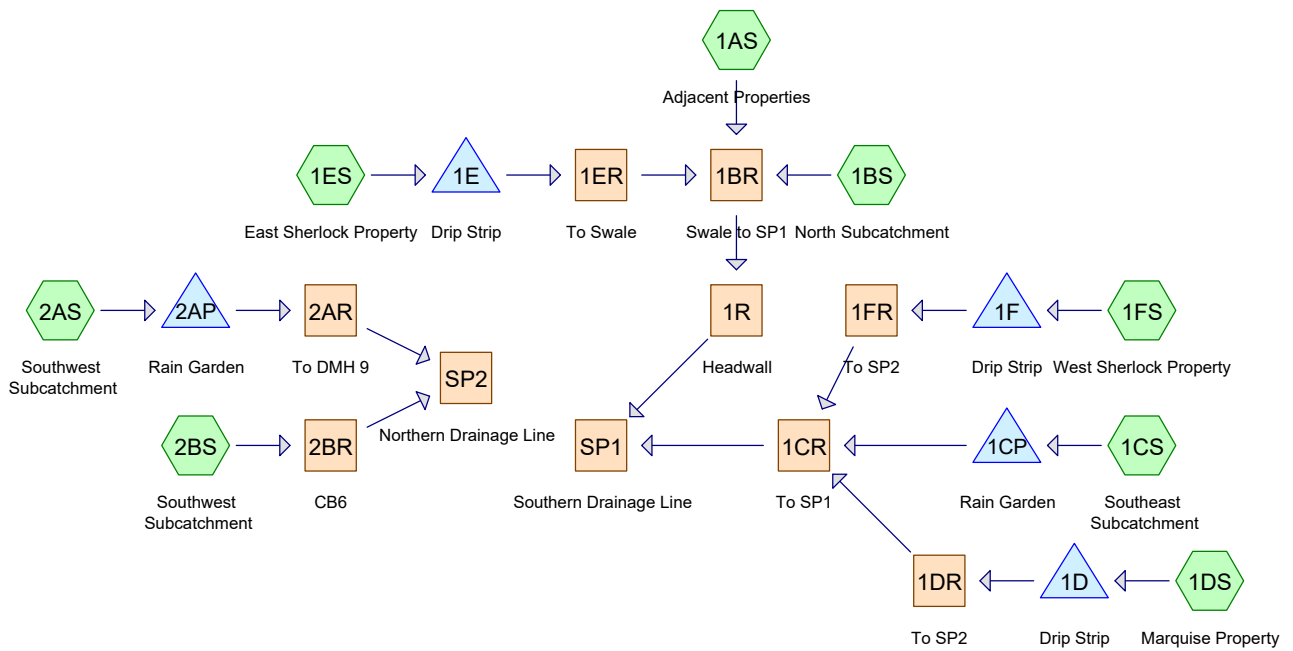

Routing Diagram for 5010658.001-Post
 Prepared by Haley Ward, Printed 6/20/2026
 HydroCAD® 10.20-9a s/n 00801 © 2026 HydroCAD Software Solutions LLC

5010658.001-Post

Prepared by Haley Ward

HydroCAD® 10.20-9a s/n 00801 © 2026 HydroCAD Software Solutions LLC

Printed 6/20/2026

Page 2

Area Listing (all nodes)

Area (sq-ft)	CN	Description (subcatchment-numbers)
44,525	61	>75% Grass cover, Good, HSG B (1AS, 1BS, 1CS, 2AS, 2BS)
1,865	98	Paved parking, HSG B (1AS, 1CS, 2BS)
3,200	98	Roofs, HSG B (1DS, 1ES, 1FS, 2AS)
3,795	98	Unconnected pavement, HSG B (1BS, 1CS, 2AS, 2BS)
53,385	67	TOTAL AREA

5010658.001-Post

Prepared by Haley Ward

HydroCAD® 10.20-9a s/n 00801 © 2026 HydroCAD Software Solutions LLC

Printed 6/20/2026

Page 3

Soil Listing (all nodes)

Area (sq-ft)	Soil Group	Subcatchment Numbers
0	HSG A	
53,385	HSG B	1AS, 1BS, 1CS, 1DS, 1ES, 1FS, 2AS, 2BS
0	HSG C	
0	HSG D	
0	Other	
53,385		TOTAL AREA

Time span=0.00-24.00 hrs, dt=0.05 hrs, 481 points
Runoff by SCS TR-20 method, UH=SCS, Weighted-CN
Reach routing by Stor-Ind+Trans method - Pond routing by Stor-Ind method

Subcatchment 1AS: Adjacent Properties Runoff Area=20,770 sf 1.64% Impervious Runoff Depth>0.70"
Tc=5.0 min CN=62 Runoff=0.32 cfs 1,213 cf

Subcatchment 1BS: North Subcatchment Runoff Area=8,190 sf 11.36% Impervious Runoff Depth>0.75"
Tc=5.0 min UI Adjusted CN=63 Runoff=0.14 cfs 511 cf

Subcatchment 1CS: Southeast Runoff Area=14,290 sf 20.19% Impervious Runoff Depth>0.90"
Tc=5.0 min UI Adjusted CN=66 Runoff=0.31 cfs 1,071 cf

Subcatchment 1DS: Marquise Property Runoff Area=680 sf 100.00% Impervious Runoff Depth>3.44"
Tc=5.0 min CN=98 Runoff=0.06 cfs 195 cf

Subcatchment 1ES: East Sherlock Property Runoff Area=685 sf 100.00% Impervious Runoff Depth>3.45"
Tc=0.0 min CN=98 Runoff=0.06 cfs 197 cf

Subcatchment 1FS: West Sherlock Property Runoff Area=875 sf 100.00% Impervious Runoff Depth>3.44"
Tc=5.0 min CN=98 Runoff=0.07 cfs 251 cf

Subcatchment 2AS: Southwest Runoff Area=5,315 sf 40.92% Impervious Runoff Depth>1.50"
Tc=5.0 min CN=76 Runoff=0.21 cfs 663 cf

Subcatchment 2BS: Southwest Runoff Area=2,580 sf 11.24% Impervious Runoff Depth>0.85"
Tc=5.0 min CN=65 Runoff=0.05 cfs 182 cf

Reach 1BR: Swale to SP1 Avg. Flow Depth=0.05' Max Vel=1.31 fps Inflow=0.50 cfs 1,776 cf
n=0.030 L=227.0' S=0.0401 '/' Capacity=23.57 cfs Outflow=0.46 cfs 1,767 cf

Reach 1CR: To SP1 Avg. Flow Depth=0.02' Max Vel=0.40 fps Inflow=0.35 cfs 1,124 cf
n=0.025 L=161.0' S=0.0093 '/' Capacity=64.03 cfs Outflow=0.26 cfs 1,115 cf

Reach 1DR: To SP2 Inflow=0.06 cfs 45 cf
Outflow=0.06 cfs 45 cf

Reach 1ER: To Swale Avg. Flow Depth=0.02' Max Vel=0.49 fps Inflow=0.07 cfs 53 cf
n=0.033 L=60.0' S=0.0183 '/' Capacity=10.72 cfs Outflow=0.05 cfs 53 cf

Reach 1FR: To SP2 Avg. Flow Depth=0.00' Max Vel=0.13 fps Inflow=0.02 cfs 15 cf
n=0.030 L=660.0' S=0.0079 '/' Capacity=21.43 cfs Outflow=0.00 cfs 15 cf

Reach 1R: Headwall Avg. Flow Depth=0.23' Max Vel=3.47 fps Inflow=0.46 cfs 1,767 cf
24.0" Round Pipe n=0.025 L=58.3' S=0.0497 '/' Capacity=4.13 cfs Outflow=0.45 cfs 1,766 cf

Reach 2AR: To DMH 9 Avg. Flow Depth=0.04' Max Vel=1.06 fps Inflow=0.02 cfs 236 cf
24.0" Round Pipe n=0.012 L=158.0' S=0.0094 '/' Capacity=23.80 cfs Outflow=0.02 cfs 234 cf

Reach 2BR: CB6 Avg. Flow Depth=0.00' Max Vel=0.50 fps Inflow=0.05 cfs 182 cf
n=0.013 L=158.0' S=0.0222 '/' Capacity=136.36 cfs Outflow=0.04 cfs 182 cf

5010658.001-Post

Prepared by Haley Ward

HydroCAD® 10.20-9a s/n 00801 © 2026 HydroCAD Software Solutions LLC

Type III 24-hr 2-Yr Rainfall=3.68"

Printed 6/20/2026

Page 5

Reach SP1: Southern Drainage Line

Inflow=0.61 cfs 2,881 cf
Outflow=0.61 cfs 2,881 cf

Reach SP2: Northern Drainage Line

Inflow=0.04 cfs 416 cf
Outflow=0.04 cfs 416 cf

Pond 1CP: Rain Garden

Peak Elev=10.51' Storage=130 cf Inflow=0.31 cfs 1,071 cf
Outflow=0.29 cfs 1,063 cf

Pond 1D: Drip Strip

Peak Elev=22.25' Storage=56 cf Inflow=0.06 cfs 195 cf
Discarded=0.00 cfs 142 cf Primary=0.06 cfs 45 cf Outflow=0.06 cfs 188 cf

Pond 1E: Drip Strip

Peak Elev=16.56' Storage=51 cf Inflow=0.06 cfs 197 cf
Discarded=0.00 cfs 138 cf Primary=0.07 cfs 53 cf Outflow=0.07 cfs 191 cf

Pond 1F: Drip Strip

Peak Elev=18.62' Storage=99 cf Inflow=0.07 cfs 251 cf
Discarded=0.01 cfs 233 cf Primary=0.02 cfs 15 cf Outflow=0.02 cfs 248 cf

Pond 2AP: Rain Garden

Peak Elev=17.51' Storage=430 cf Inflow=0.21 cfs 663 cf
Outflow=0.02 cfs 236 cf

Total Runoff Area = 53,385 sf Runoff Volume = 4,282 cf Average Runoff Depth = 0.96"
83.40% Pervious = 44,525 sf 16.60% Impervious = 8,860 sf

Time span=0.00-24.00 hrs, dt=0.05 hrs, 481 points
Runoff by SCS TR-20 method, UH=SCS, Weighted-CN
Reach routing by Stor-Ind+Trans method - Pond routing by Stor-Ind method

Subcatchment 1AS: Adjacent Properties Runoff Area=20,770 sf 1.64% Impervious Runoff Depth>1.81"
Tc=5.0 min CN=62 Runoff=0.97 cfs 3,139 cf

Subcatchment 1BS: North Subcatchment Runoff Area=8,190 sf 11.36% Impervious Runoff Depth>1.89"
Tc=5.0 min UI Adjusted CN=63 Runoff=0.40 cfs 1,292 cf

Subcatchment 1CS: Southeast Runoff Area=14,290 sf 20.19% Impervious Runoff Depth>2.14"
Tc=5.0 min UI Adjusted CN=66 Runoff=0.81 cfs 2,547 cf

Subcatchment 1DS: Marquise Property Runoff Area=680 sf 100.00% Impervious Runoff Depth>5.35"
Tc=5.0 min CN=98 Runoff=0.09 cfs 303 cf

Subcatchment 1ES: East Sherlock Property Runoff Area=685 sf 100.00% Impervious Runoff Depth>5.35"
Tc=0.0 min CN=98 Runoff=0.10 cfs 306 cf

Subcatchment 1FS: West Sherlock Property Runoff Area=875 sf 100.00% Impervious Runoff Depth>5.35"
Tc=5.0 min CN=98 Runoff=0.11 cfs 390 cf

Subcatchment 2AS: Southwest Runoff Area=5,315 sf 40.92% Impervious Runoff Depth>3.03"
Tc=5.0 min CN=76 Runoff=0.43 cfs 1,341 cf

Subcatchment 2BS: Southwest Runoff Area=2,580 sf 11.24% Impervious Runoff Depth>2.06"
Tc=5.0 min CN=65 Runoff=0.14 cfs 442 cf

Reach 1BR: Swale to SP1 Avg. Flow Depth=0.10' Max Vel=2.02 fps Inflow=1.45 cfs 4,561 cf
n=0.030 L=227.0' S=0.0401 '/' Capacity=23.57 cfs Outflow=1.36 cfs 4,547 cf

Reach 1CR: To SP1 Avg. Flow Depth=0.04' Max Vel=0.62 fps Inflow=0.87 cfs 2,760 cf
n=0.025 L=161.0' S=0.0093 '/' Capacity=64.03 cfs Outflow=0.75 cfs 2,746 cf

Reach 1DR: To SP2 Inflow=0.08 cfs 122 cf
Outflow=0.08 cfs 122 cf

Reach 1ER: To Swale Avg. Flow Depth=0.03' Max Vel=0.57 fps Inflow=0.09 cfs 130 cf
n=0.033 L=60.0' S=0.0183 '/' Capacity=10.72 cfs Outflow=0.08 cfs 130 cf

Reach 1FR: To SP2 Avg. Flow Depth=0.01' Max Vel=0.17 fps Inflow=0.12 cfs 103 cf
n=0.030 L=660.0' S=0.0079 '/' Capacity=21.43 cfs Outflow=0.02 cfs 103 cf

Reach 1R: Headwall Avg. Flow Depth=0.40' Max Vel=4.72 fps Inflow=1.36 cfs 4,547 cf
24.0" Round Pipe n=0.025 L=58.3' S=0.0497 '/' Capacity=4.13 cfs Outflow=1.35 cfs 4,546 cf

Reach 2AR: To DMH 9 Avg. Flow Depth=0.17' Max Vel=2.72 fps Inflow=0.35 cfs 913 cf
24.0" Round Pipe n=0.012 L=158.0' S=0.0094 '/' Capacity=23.80 cfs Outflow=0.30 cfs 912 cf

Reach 2BR: CB6 Avg. Flow Depth=0.01' Max Vel=0.68 fps Inflow=0.14 cfs 442 cf
n=0.013 L=158.0' S=0.0222 '/' Capacity=136.36 cfs Outflow=0.12 cfs 441 cf

5010658.001-Post

Prepared by Haley Ward

HydroCAD® 10.20-9a s/n 00801 © 2026 HydroCAD Software Solutions LLC

Type III 24-hr 10-Yr Rainfall=5.59"

Printed 6/20/2026

Page 7

Reach SP1: Southern Drainage Line

Inflow=1.98 cfs 7,291 cf
Outflow=1.98 cfs 7,291 cf

Reach SP2: Northern Drainage Line

Inflow=0.42 cfs 1,353 cf
Outflow=0.42 cfs 1,353 cf

Pond 1CP: Rain Garden

Peak Elev=10.74' Storage=172 cf Inflow=0.81 cfs 2,547 cf
Outflow=0.79 cfs 2,536 cf

Pond 1D: Drip Strip

Peak Elev=22.26' Storage=56 cf Inflow=0.09 cfs 303 cf
Discarded=0.00 cfs 165 cf Primary=0.08 cfs 122 cf Outflow=0.09 cfs 287 cf

Pond 1E: Drip Strip

Peak Elev=16.57' Storage=51 cf Inflow=0.10 cfs 306 cf
Discarded=0.00 cfs 161 cf Primary=0.09 cfs 130 cf Outflow=0.10 cfs 291 cf

Pond 1F: Drip Strip

Peak Elev=18.68' Storage=105 cf Inflow=0.11 cfs 390 cf
Discarded=0.01 cfs 271 cf Primary=0.12 cfs 103 cf Outflow=0.13 cfs 374 cf

Pond 2AP: Rain Garden

Peak Elev=17.63' Storage=464 cf Inflow=0.43 cfs 1,341 cf
Outflow=0.35 cfs 913 cf

Total Runoff Area = 53,385 sf Runoff Volume = 9,760 cf Average Runoff Depth = 2.19"
83.40% Pervious = 44,525 sf 16.60% Impervious = 8,860 sf

Summary for Subcatchment 1AS: Adjacent Properties

Runoff = 0.97 cfs @ 12.09 hrs, Volume= 3,139 cf, Depth> 1.81"
 Routed to Reach 1BR : Swale to SP1

Runoff by SCS TR-20 method, UH=SCS, Weighted-CN, Time Span= 0.00-24.00 hrs, dt= 0.05 hrs
 Type III 24-hr 10-Yr Rainfall=5.59"

Area (sf)	CN	Description
340	98	Paved parking, HSG B
20,430	61	>75% Grass cover, Good, HSG B
20,770	62	Weighted Average
20,430		98.36% Pervious Area
340		1.64% Impervious Area

Tc (min)	Length (feet)	Slope (ft/ft)	Velocity (ft/sec)	Capacity (cfs)	Description
5.0					Direct Entry,

Summary for Subcatchment 1BS: North Subcatchment

Runoff = 0.40 cfs @ 12.09 hrs, Volume= 1,292 cf, Depth> 1.89"
 Routed to Reach 1BR : Swale to SP1

Runoff by SCS TR-20 method, UH=SCS, Weighted-CN, Time Span= 0.00-24.00 hrs, dt= 0.05 hrs
 Type III 24-hr 10-Yr Rainfall=5.59"

Area (sf)	CN	Adj	Description
7,260	61		>75% Grass cover, Good, HSG B
930	98		Unconnected pavement, HSG B
8,190	65	63	Weighted Average, UI Adjusted
7,260			88.64% Pervious Area
930			11.36% Impervious Area
930			100.00% Unconnected

Tc (min)	Length (feet)	Slope (ft/ft)	Velocity (ft/sec)	Capacity (cfs)	Description
5.0					Direct Entry,

Summary for Subcatchment 1CS: Southeast Subcatchment

Runoff = 0.81 cfs @ 12.08 hrs, Volume= 2,547 cf, Depth> 2.14"
 Routed to Pond 1CP : Rain Garden

Runoff by SCS TR-20 method, UH=SCS, Weighted-CN, Time Span= 0.00-24.00 hrs, dt= 0.05 hrs
 Type III 24-hr 10-Yr Rainfall=5.59"

5010658.001-Post

Type III 24-hr 10-Yr Rainfall=5.59"

Prepared by Haley Ward

Printed 6/20/2026

HydroCAD® 10.20-9a s/n 00801 © 2026 HydroCAD Software Solutions LLC

Page 9

Area (sf)	CN	Adj	Description
11,405	61		>75% Grass cover, Good, HSG B
1,295	98		Paved parking, HSG B
1,590	98		Unconnected pavement, HSG B
14,290	68	66	Weighted Average, UI Adjusted
11,405			79.81% Pervious Area
2,885			20.19% Impervious Area
1,590			55.11% Unconnected

Tc (min)	Length (feet)	Slope (ft/ft)	Velocity (ft/sec)	Capacity (cfs)	Description
5.0					Direct Entry,

Summary for Subcatchment 1DS: Marquise Property

Runoff = 0.09 cfs @ 12.07 hrs, Volume= 303 cf, Depth> 5.35"
 Routed to Pond 1D : Drip Strip

Runoff by SCS TR-20 method, UH=SCS, Weighted-CN, Time Span= 0.00-24.00 hrs, dt= 0.05 hrs
 Type III 24-hr 10-Yr Rainfall=5.59"

Area (sf)	CN	Description
680	98	Roofs, HSG B
680		100.00% Impervious Area

Tc (min)	Length (feet)	Slope (ft/ft)	Velocity (ft/sec)	Capacity (cfs)	Description
5.0					Direct Entry,

Summary for Subcatchment 1ES: East Sherlock Property

Runoff = 0.10 cfs @ 12.00 hrs, Volume= 306 cf, Depth> 5.35"
 Routed to Pond 1E : Drip Strip

Runoff by SCS TR-20 method, UH=SCS, Weighted-CN, Time Span= 0.00-24.00 hrs, dt= 0.05 hrs
 Type III 24-hr 10-Yr Rainfall=5.59"

Area (sf)	CN	Description
685	98	Roofs, HSG B
685		100.00% Impervious Area

Summary for Subcatchment 1FS: West Sherlock Property

Runoff = 0.11 cfs @ 12.07 hrs, Volume= 390 cf, Depth> 5.35"
 Routed to Pond 1F : Drip Strip

Runoff by SCS TR-20 method, UH=SCS, Weighted-CN, Time Span= 0.00-24.00 hrs, dt= 0.05 hrs
 Type III 24-hr 10-Yr Rainfall=5.59"

5010658.001-Post

Type III 24-hr 10-Yr Rainfall=5.59"

Prepared by Haley Ward

Printed 6/20/2026

HydroCAD® 10.20-9a s/n 00801 © 2026 HydroCAD Software Solutions LLC

Page 10

Area (sf)	CN	Description
875	98	Roofs, HSG B
875		100.00% Impervious Area

Tc (min)	Length (feet)	Slope (ft/ft)	Velocity (ft/sec)	Capacity (cfs)	Description
5.0					Direct Entry,

Summary for Subcatchment 2AS: Southwest Subcatchment

Runoff = 0.43 cfs @ 12.08 hrs, Volume= 1,341 cf, Depth> 3.03"
 Routed to Pond 2AP : Rain Garden

Runoff by SCS TR-20 method, UH=SCS, Weighted-CN, Time Span= 0.00-24.00 hrs, dt= 0.05 hrs
 Type III 24-hr 10-Yr Rainfall=5.59"

Area (sf)	CN	Description
1,215	98	Unconnected pavement, HSG B
960	98	Roofs, HSG B
3,140	61	>75% Grass cover, Good, HSG B
5,315	76	Weighted Average
3,140		59.08% Pervious Area
2,175		40.92% Impervious Area
1,215		55.86% Unconnected

Tc (min)	Length (feet)	Slope (ft/ft)	Velocity (ft/sec)	Capacity (cfs)	Description
5.0					Direct Entry,

Summary for Subcatchment 2BS: Southwest Subcatchment

Runoff = 0.14 cfs @ 12.08 hrs, Volume= 442 cf, Depth> 2.06"
 Routed to Reach 2BR : CB6

Runoff by SCS TR-20 method, UH=SCS, Weighted-CN, Time Span= 0.00-24.00 hrs, dt= 0.05 hrs
 Type III 24-hr 10-Yr Rainfall=5.59"

Area (sf)	CN	Description
230	98	Paved parking, HSG B
60	98	Unconnected pavement, HSG B
2,290	61	>75% Grass cover, Good, HSG B
2,580	65	Weighted Average
2,290		88.76% Pervious Area
290		11.24% Impervious Area
60		20.69% Unconnected

5010658.001-Post

Prepared by Haley Ward

HydroCAD® 10.20-9a s/n 00801 © 2026 HydroCAD Software Solutions LLC

Type III 24-hr 10-Yr Rainfall=5.59"

Printed 6/20/2026

Page 11

Tc (min)	Length (feet)	Slope (ft/ft)	Velocity (ft/sec)	Capacity (cfs)	Description
5.0					Direct Entry,

Summary for Reach 1BR: Swale to SP1

Inflow Area = 29,645 sf, 6.59% Impervious, Inflow Depth > 1.85" for 10-Yr event
 Inflow = 1.45 cfs @ 12.09 hrs, Volume= 4,561 cf
 Outflow = 1.36 cfs @ 12.14 hrs, Volume= 4,547 cf, Atten= 6%, Lag= 3.5 min
 Routed to Reach 1R : Headwall

Routing by Stor-Ind+Trans method, Time Span= 0.00-24.00 hrs, dt= 0.05 hrs
 Max. Velocity= 2.02 fps, Min. Travel Time= 1.9 min
 Avg. Velocity = 0.60 fps, Avg. Travel Time= 6.3 min

Peak Storage= 159 cf @ 12.11 hrs
 Average Depth at Peak Storage= 0.10' , Surface Width= 7.58'
 Bank-Full Depth= 0.50' Flow Area= 4.3 sf, Capacity= 23.57 cfs

7.00' x 0.50' deep channel, n= 0.030 Earth, grassed & winding
 Side Slope Z-value= 3.0 '/' Top Width= 10.00'
 Length= 227.0' Slope= 0.0401 '/'
 Inlet Invert= 24.00', Outlet Invert= 14.90'



Summary for Reach 1CR: To SP1

Inflow Area = 15,845 sf, 28.02% Impervious, Inflow Depth > 2.09" for 10-Yr event
 Inflow = 0.87 cfs @ 12.10 hrs, Volume= 2,760 cf
 Outflow = 0.75 cfs @ 12.22 hrs, Volume= 2,746 cf, Atten= 14%, Lag= 7.1 min
 Routed to Reach SP1 : Southern Drainage Line

Routing by Stor-Ind+Trans method, Time Span= 0.00-24.00 hrs, dt= 0.05 hrs
 Max. Velocity= 0.62 fps, Min. Travel Time= 4.3 min
 Avg. Velocity = 0.21 fps, Avg. Travel Time= 13.0 min

Peak Storage= 201 cf @ 12.15 hrs
 Average Depth at Peak Storage= 0.04' , Surface Width= 35.21'
 Bank-Full Depth= 0.50' Flow Area= 18.3 sf, Capacity= 64.03 cfs

35.00' x 0.50' deep channel, n= 0.025 Earth, clean & winding
 Side Slope Z-value= 3.0 '/' Top Width= 38.00'
 Length= 161.0' Slope= 0.0093 '/'
 Inlet Invert= 14.50', Outlet Invert= 13.00'



Summary for Reach 1DR: To SP2

Inflow Area = 680 sf, 100.00% Impervious, Inflow Depth = 2.15" for 10-Yr event
 Inflow = 0.08 cfs @ 12.08 hrs, Volume= 122 cf
 Outflow = 0.08 cfs @ 12.08 hrs, Volume= 122 cf, Atten= 0%, Lag= 0.0 min
 Routed to Reach 1CR : To SP1

Routing by Stor-Ind+Trans method, Time Span= 0.00-24.00 hrs, dt= 0.05 hrs

Summary for Reach 1ER: To Swale

Inflow Area = 685 sf, 100.00% Impervious, Inflow Depth = 2.28" for 10-Yr event
 Inflow = 0.09 cfs @ 12.01 hrs, Volume= 130 cf
 Outflow = 0.08 cfs @ 12.06 hrs, Volume= 130 cf, Atten= 10%, Lag= 3.1 min
 Routed to Reach 1BR : Swale to SP1

Routing by Stor-Ind+Trans method, Time Span= 0.00-24.00 hrs, dt= 0.05 hrs
 Max. Velocity= 0.57 fps, Min. Travel Time= 1.7 min
 Avg. Velocity = 0.23 fps, Avg. Travel Time= 4.4 min

Peak Storage= 9 cf @ 12.03 hrs
 Average Depth at Peak Storage= 0.03' , Surface Width= 5.18'
 Bank-Full Depth= 0.50' Flow Area= 3.3 sf, Capacity= 10.72 cfs

5.00' x 0.50' deep channel, n= 0.033 Earth, grassed & winding
 Side Slope Z-value= 3.0 ' / ' Top Width= 8.00'
 Length= 60.0' Slope= 0.0183 ' / '
 Inlet Invert= 17.10', Outlet Invert= 16.00'



Summary for Reach 1FR: To SP2

Inflow Area = 875 sf, 100.00% Impervious, Inflow Depth = 1.41" for 10-Yr event
 Inflow = 0.12 cfs @ 12.11 hrs, Volume= 103 cf
 Outflow = 0.02 cfs @ 13.63 hrs, Volume= 103 cf, Atten= 86%, Lag= 91.2 min
 Routed to Reach 1CR : To SP1

5010658.001-Post

Prepared by Haley Ward

HydroCAD® 10.20-9a s/n 00801 © 2026 HydroCAD Software Solutions LLC

Type III 24-hr 10-Yr Rainfall=5.59"

Printed 6/20/2026

Page 13

Routing by Stor-Ind+Trans method, Time Span= 0.00-24.00 hrs, dt= 0.05 hrs
Max. Velocity= 0.17 fps, Min. Travel Time= 66.7 min
Avg. Velocity = 0.13 fps, Avg. Travel Time= 84.3 min

Peak Storage= 65 cf @ 12.52 hrs
Average Depth at Peak Storage= 0.01' , Surface Width= 15.04'
Bank-Full Depth= 0.50' Flow Area= 8.3 sf, Capacity= 21.43 cfs

15.00' x 0.50' deep channel, n= 0.030 Earth, grassed & winding
Side Slope Z-value= 3.0 '/' Top Width= 18.00'
Length= 660.0' Slope= 0.0079 '/'
Inlet Invert= 19.20', Outlet Invert= 14.00'



Summary for Reach 1R: Headwall

Inflow Area = 29,645 sf, 6.59% Impervious, Inflow Depth > 1.84" for 10-Yr event
Inflow = 1.36 cfs @ 12.14 hrs, Volume= 4,547 cf
Outflow = 1.35 cfs @ 12.15 hrs, Volume= 4,546 cf, Atten= 1%, Lag= 0.3 min
Routed to Reach SP1 : Southern Drainage Line

Routing by Stor-Ind+Trans method, Time Span= 0.00-24.00 hrs, dt= 0.05 hrs
Max. Velocity= 4.72 fps, Min. Travel Time= 0.2 min
Avg. Velocity = 1.87 fps, Avg. Travel Time= 0.5 min

Peak Storage= 17 cf @ 12.15 hrs
Average Depth at Peak Storage= 0.40' , Surface Width= 0.98'
Bank-Full Depth= 1.00' Flow Area= 0.8 sf, Capacity= 4.13 cfs

12.0" Round Pipe
n= 0.025 Earth, clean & winding
Length= 58.3' Slope= 0.0497 '/'
Inlet Invert= 14.90', Outlet Invert= 12.00'

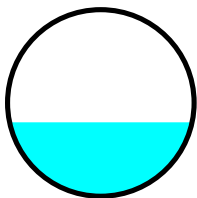

Summary for Reach 2AR: To DMH 9

Inflow Area = 5,315 sf, 40.92% Impervious, Inflow Depth > 2.06" for 10-Yr event
Inflow = 0.35 cfs @ 12.17 hrs, Volume= 913 cf
Outflow = 0.30 cfs @ 12.22 hrs, Volume= 912 cf, Atten= 14%, Lag= 2.9 min
Routed to Reach SP2 : Northern Drainage Line

Routing by Stor-Ind+Trans method, Time Span= 0.00-24.00 hrs, dt= 0.05 hrs
Max. Velocity= 2.72 fps, Min. Travel Time= 1.0 min
Avg. Velocity = 1.07 fps, Avg. Travel Time= 2.5 min

Peak Storage= 20 cf @ 12.20 hrs
Average Depth at Peak Storage= 0.17' , Surface Width= 1.11'
Bank-Full Depth= 2.00' Flow Area= 3.1 sf, Capacity= 23.80 cfs

24.0" Round Pipe
n= 0.012 Corrugated PP, smooth interior
Length= 158.0' Slope= 0.0094 '/'
Inlet Invert= 9.77', Outlet Invert= 8.28'

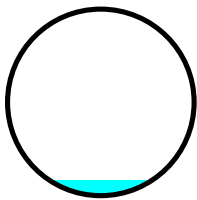

Summary for Reach 2BR: CB6

Inflow Area = 2,580 sf, 11.24% Impervious, Inflow Depth > 2.06" for 10-Yr event
Inflow = 0.14 cfs @ 12.08 hrs, Volume= 442 cf
Outflow = 0.12 cfs @ 12.20 hrs, Volume= 441 cf, Atten= 12%, Lag= 6.7 min
Routed to Reach SP2 : Northern Drainage Line

Routing by Stor-Ind+Trans method, Time Span= 0.00-24.00 hrs, dt= 0.05 hrs
Max. Velocity= 0.68 fps, Min. Travel Time= 3.9 min
Avg. Velocity = 0.50 fps, Avg. Travel Time= 5.3 min

Peak Storage= 29 cf @ 12.12 hrs
Average Depth at Peak Storage= 0.01' , Surface Width= 25.04'
Bank-Full Depth= 0.50' Flow Area= 13.3 sf, Capacity= 136.36 cfs

25.00' x 0.50' deep channel, n= 0.013 Asphalt, smooth
Side Slope Z-value= 3.0 '/' Top Width= 28.00'
Length= 158.0' Slope= 0.0222 '/'
Inlet Invert= 19.00', Outlet Invert= 15.50'



Summary for Reach SP1: Southern Drainage Line

Inflow Area = 45,490 sf, 14.06% Impervious, Inflow Depth > 1.92" for 10-Yr event
 Inflow = 1.98 cfs @ 12.17 hrs, Volume= 7,291 cf
 Outflow = 1.98 cfs @ 12.17 hrs, Volume= 7,291 cf, Atten= 0%, Lag= 0.0 min

Routing by Stor-Ind+Trans method, Time Span= 0.00-24.00 hrs, dt= 0.05 hrs

Summary for Reach SP2: Northern Drainage Line

Inflow Area = 7,895 sf, 31.22% Impervious, Inflow Depth > 2.06" for 10-Yr event
 Inflow = 0.42 cfs @ 12.21 hrs, Volume= 1,353 cf
 Outflow = 0.42 cfs @ 12.21 hrs, Volume= 1,353 cf, Atten= 0%, Lag= 0.0 min

Routing by Stor-Ind+Trans method, Time Span= 0.00-24.00 hrs, dt= 0.05 hrs

Summary for Pond 1CP: Rain Garden

Inflow Area = 14,290 sf, 20.19% Impervious, Inflow Depth > 2.14" for 10-Yr event
 Inflow = 0.81 cfs @ 12.08 hrs, Volume= 2,547 cf
 Outflow = 0.79 cfs @ 12.11 hrs, Volume= 2,536 cf, Atten= 2%, Lag= 1.3 min
 Primary = 0.79 cfs @ 12.11 hrs, Volume= 2,536 cf
 Routed to Reach 1CR : To SP1

Routing by Stor-Ind method, Time Span= 0.00-24.00 hrs, dt= 0.05 hrs
 Automatic Starting Elev= 10.20' Surf.Area= 458 sf Storage= 73 cf
 Peak Elev= 10.74' @ 12.11 hrs Surf.Area= 458 sf Storage= 172 cf (98 cf above start)

Plug-Flow detention time= 28.1 min calculated for 2,462 cf (97% of inflow)
 Center-of-Mass det. time= 3.8 min (854.1 - 850.2)

Volume	Invert	Avail.Storage	Storage Description			
#1	9.80'	1,111 cf	Custom Stage Data (Irregular) Listed below (Recalc)			
Elevation (feet)	Surf.Area (sq-ft)	Perim. (feet)	Voids (%)	Inc.Store (cubic-feet)	Cum.Store (cubic-feet)	Wet.Area (sq-ft)
9.80	458	85.0	0.0	0	0	458
10.20	458	85.0	40.0	73	73	492
14.50	458	85.0	40.0	788	861	857
15.00	545	91.0	100.0	250	1,111	952

Device	Routing	Invert	Outlet Devices
#1	Primary	14.50'	12.0" Horiz. Orifice/Grate C= 0.600 Limited to weir flow at low heads

5010658.001-Post

Prepared by Haley Ward

HydroCAD® 10.20-9a s/n 00801 © 2026 HydroCAD Software Solutions LLC

Type III 24-hr 10-Yr Rainfall=5.59"

Printed 6/20/2026

Page 16

#2 Primary 10.20' **12.0" Round Culvert**
 L= 45.8' CPP, square edge headwall, Ke= 0.500
 Inlet / Outlet Invert= 10.20' / 10.00' S= 0.0044 ' S= 0.0044 ' Cc= 0.900
 n= 0.012 Corrugated PP, smooth interior, Flow Area= 0.79 sf

Primary OutFlow Max=0.78 cfs @ 12.11 hrs HW=10.73' (Free Discharge)

- ↑1=Orifice/Grate (Controls 0.00 cfs)
- ↓2=Culvert (Barrel Controls 0.78 cfs @ 2.67 fps)

Summary for Pond 1D: Drip Strip

Inflow Area = 680 sf, 100.00% Impervious, Inflow Depth > 5.35" for 10-Yr event
 Inflow = 0.09 cfs @ 12.07 hrs, Volume= 303 cf
 Outflow = 0.09 cfs @ 12.08 hrs, Volume= 287 cf, Atten= 1%, Lag= 0.8 min
 Discarded = 0.00 cfs @ 12.08 hrs, Volume= 165 cf
 Primary = 0.08 cfs @ 12.08 hrs, Volume= 122 cf
 Routed to Reach 1DR : To SP2

Routing by Stor-Ind method, Time Span= 0.00-24.00 hrs, dt= 0.05 hrs
 Peak Elev= 22.26' @ 12.08 hrs Surf.Area= 136 sf Storage= 56 cf

Plug-Flow detention time= 110.3 min calculated for 286 cf (94% of inflow)
 Center-of-Mass det. time= 79.6 min (824.6 - 745.0)

Volume	Invert	Avail.Storage	Storage Description
#1	20.70'	83 cf	2.00'W x 23.50'L x 2.00'H Prismaoid Z=1.0 207 cf Overall x 40.0% Voids

Device	Routing	Invert	Outlet Devices
#1	Primary	22.20'	2.0' long + 1.0 ' SideZ x 1.0' breadth Broad-Crested Rectangular Weir Head (feet) 0.20 0.40 0.60 0.80 1.00 1.20 1.40 1.60 1.80 2.00 2.50 3.00 Coef. (English) 2.69 2.72 2.75 2.85 2.98 3.08 3.20 3.28 3.31 3.30 3.31 3.32
#2	Discarded	20.70'	1.000 in/hr Exfiltration over Surface area

Discarded OutFlow Max=0.00 cfs @ 12.08 hrs HW=22.26' (Free Discharge)

- ↑2=Exfiltration (Exfiltration Controls 0.00 cfs)

Primary OutFlow Max=0.08 cfs @ 12.08 hrs HW=22.26' (Free Discharge)

- ↑1=Broad-Crested Rectangular Weir (Weir Controls 0.08 cfs @ 0.65 fps)

Summary for Pond 1E: Drip Strip

Inflow Area = 685 sf, 100.00% Impervious, Inflow Depth > 5.35" for 10-Yr event
 Inflow = 0.10 cfs @ 12.00 hrs, Volume= 306 cf
 Outflow = 0.10 cfs @ 12.01 hrs, Volume= 291 cf, Atten= 2%, Lag= 0.4 min
 Discarded = 0.00 cfs @ 12.01 hrs, Volume= 161 cf
 Primary = 0.09 cfs @ 12.01 hrs, Volume= 130 cf
 Routed to Reach 1ER : To Swale

5010658.001-Post

Type III 24-hr 10-Yr Rainfall=5.59"

Prepared by Haley Ward

Printed 6/20/2026

HydroCAD® 10.20-9a s/n 00801 © 2026 HydroCAD Software Solutions LLC

Page 17

Routing by Stor-Ind method, Time Span= 0.00-24.00 hrs, dt= 0.05 hrs
 Peak Elev= 16.57' @ 12.01 hrs Surf.Area= 130 sf Storage= 51 cf

Plug-Flow detention time= 101.3 min calculated for 291 cf (95% of inflow)
 Center-of-Mass det. time= 74.0 min (814.6 - 740.7)

Volume	Invert	Avail.Storage	Storage Description
#1	15.10'	83 cf	2.00'W x 23.50'L x 2.00'H Prismaoid Z=1.0 207 cf Overall x 40.0% Voids

Device	Routing	Invert	Outlet Devices
#1	Primary	16.50'	2.0' long + 1.0 ' SideZ x 1.0' breadth Broad-Crested Rectangular Weir Head (feet) 0.20 0.40 0.60 0.80 1.00 1.20 1.40 1.60 1.80 2.00 2.50 3.00 Coef. (English) 2.69 2.72 2.75 2.85 2.98 3.08 3.20 3.28 3.31 3.30 3.31 3.32
#2	Discarded	15.10'	1.000 in/hr Exfiltration over Surface area

Discarded OutFlow Max=0.00 cfs @ 12.01 hrs HW=16.56' (Free Discharge)
 ↑**2=Exfiltration** (Exfiltration Controls 0.00 cfs)

Primary OutFlow Max=0.09 cfs @ 12.01 hrs HW=16.56' (Free Discharge)
 ↑**1=Broad-Crested Rectangular Weir** (Weir Controls 0.09 cfs @ 0.68 fps)

Summary for Pond 1F: Drip Strip

Inflow Area = 875 sf, 100.00% Impervious, Inflow Depth > 5.35" for 10-Yr event
 Inflow = 0.11 cfs @ 12.07 hrs, Volume= 390 cf
 Outflow = 0.13 cfs @ 12.11 hrs, Volume= 374 cf, Atten= 0%, Lag= 2.2 min
 Discarded = 0.01 cfs @ 12.11 hrs, Volume= 271 cf
 Primary = 0.12 cfs @ 12.11 hrs, Volume= 103 cf
 Routed to Reach 1FR : To SP2

Routing by Stor-Ind method, Time Span= 0.00-24.00 hrs, dt= 0.05 hrs
 Peak Elev= 18.68' @ 12.11 hrs Surf.Area= 246 sf Storage= 105 cf

Plug-Flow detention time= 134.7 min calculated for 373 cf (96% of inflow)
 Center-of-Mass det. time= 109.3 min (854.3 - 745.0)

Volume	Invert	Avail.Storage	Storage Description
#1	17.10'	150 cf	2.00'W x 44.50'L x 2.00'H Prismaoid Z=1.0 375 cf Overall x 40.0% Voids

Device	Routing	Invert	Outlet Devices
#1	Primary	18.60'	2.0' long + 1.0 ' SideZ x 1.0' breadth Broad-Crested Rectangular Weir Head (feet) 0.20 0.40 0.60 0.80 1.00 1.20 1.40 1.60 1.80 2.00 2.50 3.00 Coef. (English) 2.69 2.72 2.75 2.85 2.98 3.08 3.20 3.28 3.31 3.30 3.31 3.32
#2	Discarded	17.10'	1.000 in/hr Exfiltration over Surface area

5010658.001-Post

Prepared by Haley Ward

HydroCAD® 10.20-9a s/n 00801 © 2026 HydroCAD Software Solutions LLC

Type III 24-hr 10-Yr Rainfall=5.59"

Printed 6/20/2026

Page 18

Discarded OutFlow Max=0.01 cfs @ 12.11 hrs HW=18.67' (Free Discharge)

↳ **2=Exfiltration** (Exfiltration Controls 0.01 cfs)

Primary OutFlow Max=0.11 cfs @ 12.11 hrs HW=18.67' (Free Discharge)

↳ **1=Broad-Crested Rectangular Weir** (Weir Controls 0.11 cfs @ 0.73 fps)

Summary for Pond 2AP: Rain Garden

Inflow Area = 5,315 sf, 40.92% Impervious, Inflow Depth > 3.03" for 10-Yr event
 Inflow = 0.43 cfs @ 12.08 hrs, Volume= 1,341 cf
 Outflow = 0.35 cfs @ 12.17 hrs, Volume= 913 cf, Atten= 18%, Lag= 5.4 min
 Primary = 0.35 cfs @ 12.17 hrs, Volume= 913 cf
 Routed to Reach 2AR : To DMH 9

Routing by Stor-Ind method, Time Span= 0.00-24.00 hrs, dt= 0.05 hrs
 Peak Elev= 17.63' @ 12.15 hrs Surf.Area= 297 sf Storage= 464 cf

Plug-Flow detention time= 161.6 min calculated for 913 cf (68% of inflow)
 Center-of-Mass det. time= 62.7 min (888.6 - 825.8)

Volume	Invert	Avail.Storage	Storage Description
#1	12.80'	587 cf	Custom Stage Data (Irregular) Listed below (Recalc)

Elevation (feet)	Surf.Area (sq-ft)	Perim. (feet)	Voids (%)	Inc.Store (cubic-feet)	Cum.Store (cubic-feet)	Wet.Area (sq-ft)
12.80	190	76.0	0.0	0	0	190
13.20	190	76.0	40.0	30	30	220
17.50	273	89.0	40.0	396	426	614
18.00	370	110.0	100.0	160	587	950

Device	Routing	Invert	Outlet Devices
#1	Primary	17.50'	8.0" Horiz. Orifice/Grate C= 0.600 Limited to weir flow at low heads

Primary OutFlow Max=0.31 cfs @ 12.17 hrs HW=17.63' (Free Discharge)

↳ **1=Orifice/Grate** (Weir Controls 0.31 cfs @ 1.16 fps)

Time span=0.00-24.00 hrs, dt=0.05 hrs, 481 points
 Runoff by SCS TR-20 method, UH=SCS, Weighted-CN
 Reach routing by Stor-Ind+Trans method - Pond routing by Stor-Ind method

Subcatchment1AS: AdjacentProperties	Runoff Area=20,770 sf 1.64% Impervious Runoff Depth>2.86" Tc=5.0 min CN=62 Runoff=1.57 cfs 4,946 cf
Subcatchment1BS: North Subcatchment	Runoff Area=8,190 sf 11.36% Impervious Runoff Depth>2.96" Tc=5.0 min UI Adjusted CN=63 Runoff=0.65 cfs 2,019 cf
Subcatchment1CS: Southeast	Runoff Area=14,290 sf 20.19% Impervious Runoff Depth>3.26" Tc=5.0 min UI Adjusted CN=66 Runoff=1.25 cfs 3,888 cf
Subcatchment1DS: Marquise Property	Runoff Area=680 sf 100.00% Impervious Runoff Depth>6.84" Tc=5.0 min CN=98 Runoff=0.11 cfs 387 cf
Subcatchment1ES: East Sherlock Property	Runoff Area=685 sf 100.00% Impervious Runoff Depth>6.84" Tc=0.0 min CN=98 Runoff=0.12 cfs 390 cf
Subcatchment1FS: West Sherlock Property	Runoff Area=875 sf 100.00% Impervious Runoff Depth>6.84" Tc=5.0 min CN=98 Runoff=0.14 cfs 499 cf
Subcatchment2AS: Southwest	Runoff Area=5,315 sf 40.92% Impervious Runoff Depth>4.33" Tc=5.0 min CN=76 Runoff=0.62 cfs 1,916 cf
Subcatchment2BS: Southwest	Runoff Area=2,580 sf 11.24% Impervious Runoff Depth>3.16" Tc=5.0 min CN=65 Runoff=0.22 cfs 680 cf
Reach 1BR: Swale to SP1	Avg. Flow Depth=0.13' Max Vel=2.43 fps Inflow=2.32 cfs 7,161 cf n=0.030 L=227.0' S=0.0401 '/' Capacity=23.57 cfs Outflow=2.17 cfs 7,143 cf
Reach 1CR: To SP1	Avg. Flow Depth=0.05' Max Vel=0.74 fps Inflow=1.34 cfs 4,240 cf n=0.025 L=161.0' S=0.0093 '/' Capacity=64.03 cfs Outflow=1.20 cfs 4,220 cf
Reach 1DR: To SP2	Inflow=0.11 cfs 186 cf Outflow=0.11 cfs 186 cf
Reach 1ER: To Swale	Avg. Flow Depth=0.03' Max Vel=0.63 fps Inflow=0.12 cfs 196 cf n=0.033 L=60.0' S=0.0183 '/' Capacity=10.72 cfs Outflow=0.11 cfs 196 cf
Reach 1FR: To SP2	Avg. Flow Depth=0.01' Max Vel=0.21 fps Inflow=0.13 cfs 179 cf n=0.030 L=660.0' S=0.0079 '/' Capacity=21.43 cfs Outflow=0.03 cfs 179 cf
Reach 1R: Headwall	Avg. Flow Depth=0.52' Max Vel=5.31 fps Inflow=2.17 cfs 7,143 cf 12.0" Round Pipe n=0.025 L=58.3' S=0.0497 '/' Capacity=4.13 cfs Outflow=2.16 cfs 7,141 cf
Reach 2AR: To DMH 9	Avg. Flow Depth=0.22' Max Vel=3.24 fps Inflow=0.61 cfs 1,488 cf 24.0" Round Pipe n=0.012 L=158.0' S=0.0094 '/' Capacity=23.80 cfs Outflow=0.59 cfs 1,486 cf
Reach 2BR: CB6	Avg. Flow Depth=0.01' Max Vel=0.79 fps Inflow=0.22 cfs 680 cf n=0.013 L=158.0' S=0.0222 '/' Capacity=136.36 cfs Outflow=0.20 cfs 678 cf

5010658.001-Post

Prepared by Haley Ward

HydroCAD® 10.20-9a s/n 00801 © 2026 HydroCAD Software Solutions LLC

Type III 24-hr 25-yr Rainfall=7.08"

Printed 6/20/2026

Page 20

Reach SP1: Southern Drainage Line

Inflow=3.22 cfs 11,361 cf
Outflow=3.22 cfs 11,361 cf

Reach SP2: Northern Drainage Line

Inflow=0.76 cfs 2,165 cf
Outflow=0.76 cfs 2,165 cf

Pond 1CP: Rain Garden

Peak Elev=10.89' Storage=201 cf Inflow=1.25 cfs 3,888 cf
Outflow=1.24 cfs 3,874 cf

Pond 1D: Drip Strip

Peak Elev=22.27' Storage=57 cf Inflow=0.11 cfs 387 cf
Discarded=0.00 cfs 179 cf Primary=0.11 cfs 186 cf Outflow=0.11 cfs 365 cf

Pond 1E: Drip Strip

Peak Elev=16.58' Storage=52 cf Inflow=0.12 cfs 390 cf
Discarded=0.00 cfs 175 cf Primary=0.12 cfs 196 cf Outflow=0.12 cfs 370 cf

Pond 1F: Drip Strip

Peak Elev=18.68' Storage=105 cf Inflow=0.14 cfs 499 cf
Discarded=0.01 cfs 294 cf Primary=0.13 cfs 179 cf Outflow=0.14 cfs 473 cf

Pond 2AP: Rain Garden

Peak Elev=17.70' Storage=484 cf Inflow=0.62 cfs 1,916 cf
Outflow=0.61 cfs 1,488 cf

Total Runoff Area = 53,385 sf Runoff Volume = 14,726 cf Average Runoff Depth = 3.31"
83.40% Pervious = 44,525 sf 16.60% Impervious = 8,860 sf

Time span=0.00-24.00 hrs, dt=0.05 hrs, 481 points
Runoff by SCS TR-20 method, UH=SCS, Weighted-CN
Reach routing by Stor-Ind+Trans method - Pond routing by Stor-Ind method

Subcatchment 1AS: Adjacent Properties Runoff Area=20,770 sf 1.64% Impervious Runoff Depth>3.94"
Tc=5.0 min CN=62 Runoff=2.19 cfs 6,814 cf

Subcatchment 1BS: North Subcatchment Runoff Area=8,190 sf 11.36% Impervious Runoff Depth>4.05"
Tc=5.0 min UI Adjusted CN=63 Runoff=0.89 cfs 2,767 cf

Subcatchment 1CS: Southeast Runoff Area=14,290 sf 20.19% Impervious Runoff Depth>4.41"
Tc=5.0 min UI Adjusted CN=66 Runoff=1.70 cfs 5,251 cf

Subcatchment 1DS: Marquise Property Runoff Area=680 sf 100.00% Impervious Runoff Depth>8.25"
Tc=5.0 min CN=98 Runoff=0.13 cfs 467 cf

Subcatchment 1ES: East Sherlock Property Runoff Area=685 sf 100.00% Impervious Runoff Depth>8.25"
Tc=0.0 min CN=98 Runoff=0.15 cfs 471 cf

Subcatchment 1FS: West Sherlock Property Runoff Area=875 sf 100.00% Impervious Runoff Depth>8.25"
Tc=5.0 min CN=98 Runoff=0.17 cfs 601 cf

Subcatchment 2AS: Southwest Runoff Area=5,315 sf 40.92% Impervious Runoff Depth>5.60"
Tc=5.0 min CN=76 Runoff=0.80 cfs 2,481 cf

Subcatchment 2BS: Southwest Runoff Area=2,580 sf 11.24% Impervious Runoff Depth>4.29"
Tc=5.0 min CN=65 Runoff=0.30 cfs 923 cf

Reach 1BR: Swale to SP1 Avg. Flow Depth=0.16' Max Vel=2.75 fps Inflow=3.21 cfs 9,842 cf
n=0.030 L=227.0' S=0.0401 '/' Capacity=23.57 cfs Outflow=3.04 cfs 9,821 cf

Reach 1CR: To SP1 Avg. Flow Depth=0.06' Max Vel=0.84 fps Inflow=1.81 cfs 5,741 cf
n=0.025 L=161.0' S=0.0093 '/' Capacity=64.03 cfs Outflow=1.66 cfs 5,717 cf

Reach 1DR: To SP2 Inflow=0.13 cfs 250 cf
Outflow=0.13 cfs 250 cf

Reach 1ER: To Swale Avg. Flow Depth=0.04' Max Vel=0.68 fps Inflow=0.15 cfs 261 cf
n=0.033 L=60.0' S=0.0183 '/' Capacity=10.72 cfs Outflow=0.13 cfs 261 cf

Reach 1FR: To SP2 Avg. Flow Depth=0.01' Max Vel=0.25 fps Inflow=0.16 cfs 255 cf
n=0.030 L=660.0' S=0.0079 '/' Capacity=21.43 cfs Outflow=0.05 cfs 255 cf

Reach 1R: Headwall Avg. Flow Depth=0.64' Max Vel=5.72 fps Inflow=3.04 cfs 9,821 cf
12.0" Round Pipe n=0.025 L=58.3' S=0.0497 '/' Capacity=4.13 cfs Outflow=3.01 cfs 9,820 cf

Reach 2AR: To DMH 9 Avg. Flow Depth=0.25' Max Vel=3.48 fps Inflow=0.78 cfs 2,053 cf
24.0" Round Pipe n=0.012 L=158.0' S=0.0094 '/' Capacity=23.80 cfs Outflow=0.75 cfs 2,051 cf

Reach 2BR: CB6 Avg. Flow Depth=0.01' Max Vel=0.92 fps Inflow=0.30 cfs 923 cf
n=0.013 L=158.0' S=0.0222 '/' Capacity=136.36 cfs Outflow=0.28 cfs 921 cf

5010658.001-Post

Prepared by Haley Ward

HydroCAD® 10.20-9a s/n 00801 © 2026 HydroCAD Software Solutions LLC

Type III 24-hr 50-Yr Rainfall=8.49"

Printed 6/20/2026

Page 22

Reach SP1: Southern Drainage Line

Inflow=4.49 cfs 15,536 cf
Outflow=4.49 cfs 15,536 cf

Reach SP2: Northern Drainage Line

Inflow=1.01 cfs 2,972 cf
Outflow=1.01 cfs 2,972 cf

Pond 1CP: Rain Garden

Peak Elev=11.04' Storage=227 cf Inflow=1.70 cfs 5,251 cf
Outflow=1.68 cfs 5,236 cf

Pond 1D: Drip Strip

Peak Elev=22.28' Storage=57 cf Inflow=0.13 cfs 467 cf
Discarded=0.00 cfs 190 cf Primary=0.13 cfs 250 cf Outflow=0.13 cfs 440 cf

Pond 1E: Drip Strip

Peak Elev=16.59' Storage=52 cf Inflow=0.15 cfs 471 cf
Discarded=0.00 cfs 185 cf Primary=0.15 cfs 261 cf Outflow=0.15 cfs 446 cf

Pond 1F: Drip Strip

Peak Elev=18.69' Storage=106 cf Inflow=0.17 cfs 601 cf
Discarded=0.01 cfs 312 cf Primary=0.16 cfs 255 cf Outflow=0.17 cfs 567 cf

Pond 2AP: Rain Garden

Peak Elev=17.74' Storage=496 cf Inflow=0.80 cfs 2,481 cf
Outflow=0.78 cfs 2,053 cf

Total Runoff Area = 53,385 sf Runoff Volume = 19,776 cf Average Runoff Depth = 4.45"
83.40% Pervious = 44,525 sf 16.60% Impervious = 8,860 sf

Extreme Precipitation Tables

Northeast Regional Climate Center

Data represents point estimates calculated from partial duration series. All precipitation amounts are displayed in inches.

Metadata for Point	
Smoothing State	Yes
Location	
Latitude	43.083 degrees North
Longitude	70.772 degrees West
Elevation	0 feet
Date/Time	Wed May 13 2026 13:43:21 GMT-0400 (Eastern Daylight Time)

Extreme Precipitation Estimates

	5min	10min	15min	30min	60min	120min		1hr	2hr	3hr	6hr	12hr	24hr	48hr		1day	2day	4day	7day	10day	
1yr	0.26	0.40	0.50	0.65	0.81	1.04	1yr	0.70	0.98	1.21	1.56	2.03	2.66	2.92	1yr	2.35	2.80	3.21	3.94	4.54	1yr
2yr	0.32	0.50	0.62	0.81	1.02	1.30	2yr	0.88	1.18	1.52	1.94	2.49	3.20	3.56	2yr	2.84	3.43	3.93	4.67	5.32	2yr
5yr	0.37	0.58	0.73	0.97	1.25	1.60	5yr	1.08	1.46	1.88	2.43	3.13	4.06	4.57	5yr	3.59	4.39	5.03	5.92	6.69	5yr
10yr	0.41	0.65	0.82	1.11	1.45	1.89	10yr	1.25	1.72	2.23	2.89	3.74	4.86	5.52	10yr	4.30	5.31	6.07	7.09	7.96	10yr
25yr	0.48	0.76	0.96	1.33	1.77	2.33	25yr	1.53	2.14	2.77	3.62	4.73	6.16	7.09	25yr	5.45	6.81	7.78	9.00	10.03	25yr
50yr	0.53	0.86	1.10	1.53	2.06	2.75	50yr	1.78	2.52	3.28	4.31	5.65	7.38	8.57	50yr	6.53	8.24	9.40	10.79	11.95	50yr
100yr	0.59	0.96	1.24	1.76	2.41	3.24	100yr	2.08	2.97	3.89	5.14	6.75	8.83	10.36	100yr	7.82	9.96	11.35	12.93	14.25	100yr
200yr	0.67	1.09	1.42	2.03	2.81	3.82	200yr	2.43	3.50	4.60	6.11	8.06	10.59	12.52	200yr	9.37	12.04	13.71	15.50	16.99	200yr
500yr	0.79	1.31	1.70	2.47	3.46	4.74	500yr	2.98	4.36	5.74	7.68	10.19	13.45	16.11	500yr	11.90	15.49	17.60	19.72	21.45	500yr

Lower Confidence Limits

	5min	10min	15min	30min	60min	120min		1hr	2hr	3hr	6hr	12hr	24hr	48hr		1day	2day	4day	7day	10day	
1yr	0.23	0.36	0.44	0.59	0.73	0.88	1yr	0.63	0.86	0.92	1.32	1.68	2.22	2.49	1yr	1.97	2.39	2.86	3.17	3.87	1yr
2yr	0.31	0.49	0.60	0.81	1.00	1.19	2yr	0.86	1.16	1.37	1.82	2.34	3.05	3.45	2yr	2.70	3.32	3.82	4.54	5.07	2yr
5yr	0.35	0.54	0.67	0.92	1.17	1.40	5yr	1.01	1.37	1.61	2.12	2.73	3.78	4.18	5yr	3.35	4.02	4.71	5.52	6.23	5yr
10yr	0.38	0.59	0.73	1.02	1.32	1.60	10yr	1.14	1.56	1.81	2.39	3.06	4.36	4.85	10yr	3.86	4.67	5.43	6.40	7.18	10yr
25yr	0.44	0.67	0.83	1.18	1.56	1.90	25yr	1.35	1.86	2.10	2.76	3.54	4.69	5.88	25yr	4.15	5.65	6.63	7.77	8.66	25yr
50yr	0.48	0.73	0.91	1.31	1.76	2.17	50yr	1.52	2.12	2.35	3.08	3.94	5.30	6.79	50yr	4.69	6.53	7.70	9.02	9.99	50yr
100yr	0.53	0.81	1.01	1.46	2.01	2.47	100yr	1.73	2.41	2.63	3.42	4.36	5.94	7.83	100yr	5.26	7.53	8.94	10.47	11.53	100yr
200yr	0.59	0.89	1.13	1.63	2.27	2.81	200yr	1.96	2.75	2.93	3.80	4.81	6.65	9.04	200yr	5.89	8.69	10.38	12.18	13.33	200yr
500yr	0.68	1.02	1.31	1.90	2.71	3.36	500yr	2.33	3.29	3.41	4.34	5.48	7.73	10.91	500yr	6.84	10.50	12.64	14.89	16.13	500yr

Upper Confidence Limits

	5min	10min	15min	30min	60min	120min		1hr	2hr	3hr	6hr	12hr	24hr	48hr		1day	2day	4day	7day	10day	
1yr	0.28	0.44	0.54	0.72	0.89	1.08	1yr	0.77	1.06	1.26	1.74	2.21	2.98	3.15	1yr	2.64	3.03	3.58	4.37	5.04	1yr
2yr	0.34	0.52	0.64	0.86	1.07	1.27	2yr	0.92	1.24	1.48	1.96	2.51	3.42	3.70	2yr	3.03	3.55	4.08	4.83	5.63	2yr
5yr	0.40	0.62	0.76	1.05	1.33	1.62	5yr	1.15	1.58	1.88	2.53	3.25	4.33	4.95	5yr	3.83	4.76	5.37	6.36	7.14	5yr
10yr	0.47	0.72	0.89	1.24	1.61	1.97	10yr	1.39	1.93	2.28	3.10	3.95	5.33	6.19	10yr	4.72	5.95	6.80	7.82	8.73	10yr
25yr	0.57	0.87	1.09	1.55	2.04	2.56	25yr	1.76	2.50	2.95	4.06	5.14	7.79	8.32	25yr	6.90	8.00	9.12	10.32	11.39	25yr
50yr	0.67	1.02	1.27	1.82	2.45	3.12	50yr	2.11	3.05	3.59	4.99	6.30	9.76	10.43	50yr	8.64	10.03	11.41	12.70	13.94	50yr
100yr	0.79	1.19	1.49	2.15	2.95	3.79	100yr	2.54	3.71	4.36	6.14	7.73	12.22	13.08	100yr	10.81	12.57	14.26	15.66	17.06	100yr
200yr	0.92	1.38	1.75	2.53	3.53	4.63	200yr	3.05	4.52	5.32	7.56	9.49	15.34	16.41	200yr	13.57	15.78	17.86	19.30	20.88	200yr
500yr	1.14	1.69	2.18	3.17	4.50	6.00	500yr	3.89	5.87	6.91	9.99	12.48	20.74	22.15	500yr	18.35	21.30	24.04	25.45	27.30	500yr



Custom Soil Resource Report Soil Map



Soil Map may not be valid at this scale.

Map Scale: 1:424 if printed on A landscape (11" x 8.5") sheet.

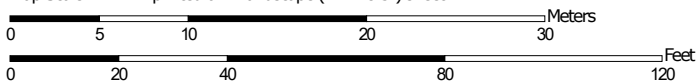

Map projection: Web Mercator Corner coordinates: WGS84 Edge tics: UTM Zone 19N WGS84

MAP LEGEND

Area of Interest (AOI)

 Area of Interest (AOI)



















Soils







 Soil Map Unit Polygons

 Soil Map Unit Lines

 Soil Map Unit Points

Special Point Features





-  Blowout
-  Borrow Pit
-  Clay Spot
-  Closed Depression
-  Gravel Pit
-  Gravelly Spot
-  Landfill
-  Lava Flow
-  Marsh or swamp
-  Mine or Quarry
-  Miscellaneous Water
-  Perennial Water
-  Rock Outcrop
-  Saline Spot
-  Sandy Spot
-  Severely Eroded Spot
-  Sinkhole
-  Slide or Slip
-  Sodic Spot

-  Spoil Area
-  Stony Spot
-  Very Stony Spot
-  Wet Spot
-  Other
-  Special Line Features

Water Features

 Streams and Canals

Transportation

-  Rails
-  Interstate Highways
-  US Routes
-  Major Roads
-  Local Roads

Background

 Aerial Photography

MAP INFORMATION

The soil surveys that comprise your AOI were mapped at 1:24,000.

Warning: Soil Map may not be valid at this scale.

Enlargement of maps beyond the scale of mapping can cause misunderstanding of the detail of mapping and accuracy of soil line placement. The maps do not show the small areas of contrasting soils that could have been shown at a more detailed scale.

Please rely on the bar scale on each map sheet for map measurements.

Source of Map: Natural Resources Conservation Service
 Web Soil Survey URL:
 Coordinate System: Web Mercator (EPSG:3857)

Maps from the Web Soil Survey are based on the Web Mercator projection, which preserves direction and shape but distorts distance and area. A projection that preserves area, such as the Albers equal-area conic projection, should be used if more accurate calculations of distance or area are required.

This product is generated from the USDA-NRCS certified data as of the version date(s) listed below.

Soil Survey Area: Rockingham County, New Hampshire
 Survey Area Data: Version 28, Sep 9, 2025

Soil map units are labeled (as space allows) for map scales 1:50,000 or larger.

Date(s) aerial images were photographed: Jun 19, 2020—Sep 20, 2020

The orthophoto or other base map on which the soil lines were compiled and digitized probably differs from the background imagery displayed on these maps. As a result, some minor shifting of map unit boundaries may be evident.

Map Unit Legend

Map Unit Symbol	Map Unit Name	Acres in AOI	Percent of AOI
799	Urban land-Canton complex, 3 to 15 percent slopes	0.7	100.0%
Totals for Area of Interest		0.7	100.0%

National Flood Hazard Layer FIRMette



70°46'40"W 43°5'10"N

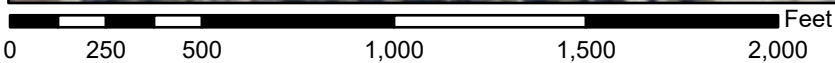
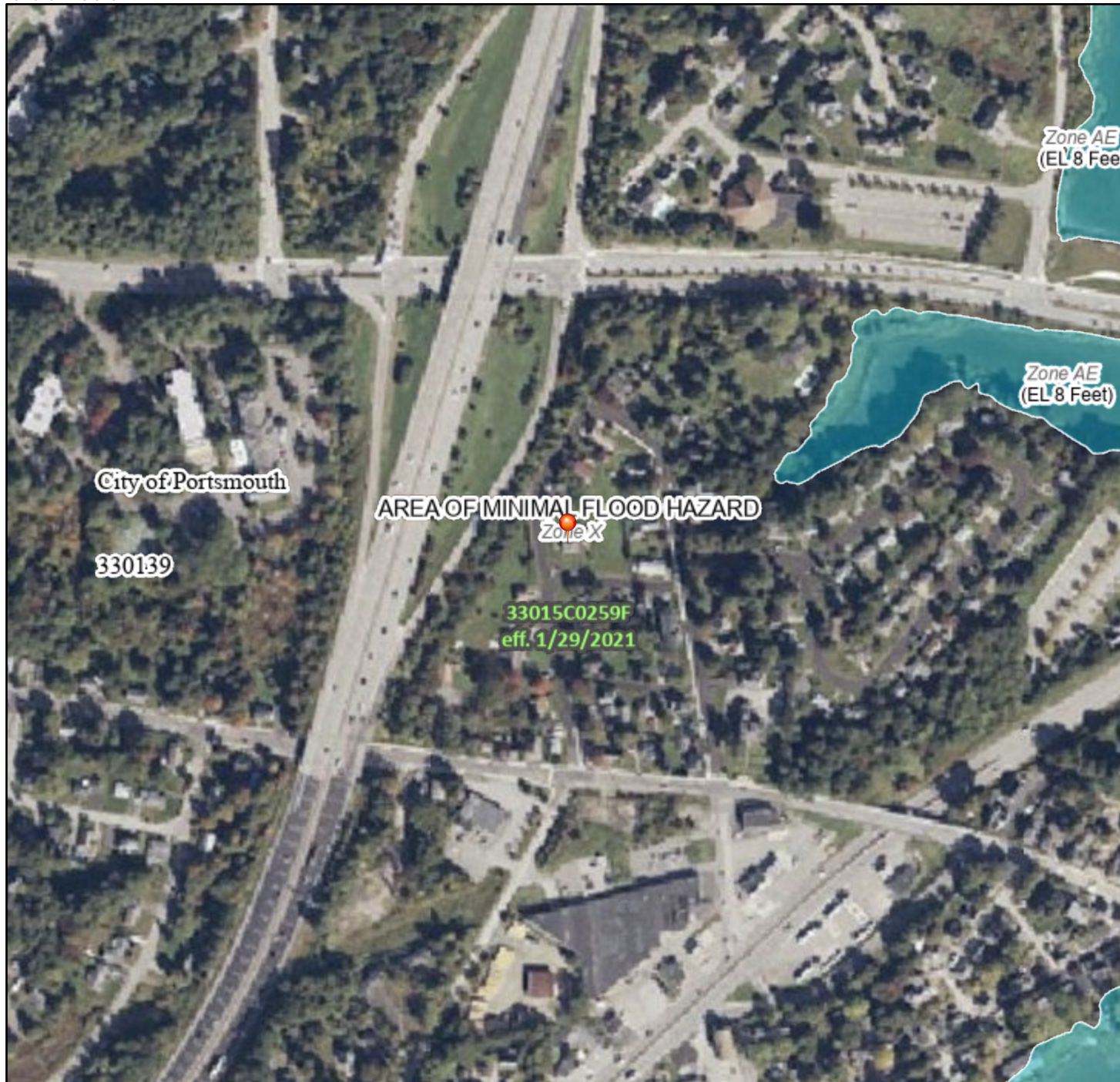

1:6,000

70°46'3"W 43°4'44"N

Basemap Imagery Source: USGS National Map 2023

Legend

SEE FIS REPORT FOR DETAILED LEGEND AND INDEX MAP FOR FIRM PANEL LAYOUT

SPECIAL FLOOD HAZARD AREAS		Without Base Flood Elevation (BFE) Zone A, V, A99
		With BFE or Depth Zone AE, AO, AH, VE, AR
		Regulatory Floodway
OTHER AREAS OF FLOOD HAZARD		0.2% Annual Chance Flood Hazard, Areas of 1% annual chance flood with average depth less than one foot or with drainage areas of less than one square mile Zone X
		Future Conditions 1% Annual Chance Flood Hazard Zone X
		Area with Reduced Flood Risk due to Levee. See Notes. Zone X
		Area with Flood Risk due to Levee Zone D
OTHER AREAS		NO SCREEN Area of Minimal Flood Hazard Zone X
		Effective LOMRs
		Area of Undetermined Flood Hazard Zone D
GENERAL STRUCTURES		Channel, Culvert, or Storm Sewer
		Levee, Dike, or Floodwall
OTHER FEATURES		20.2 Cross Sections with 1% Annual Chance Water Surface Elevation
		17.5
		Coastal Transect
		Base Flood Elevation Line (BFE)
		Limit of Study
		Jurisdiction Boundary
		Coastal Transect Baseline
	Profile Baseline	
MAP PANELS		Digital Data Available
		No Digital Data Available
		Unmapped
		The pin displayed on the map is an approximate point selected by the user and does not represent an authoritative property location.



This map complies with FEMA's standards for the use of digital flood maps if it is not void as described below. The basemap shown complies with FEMA's basemap accuracy standards

The flood hazard information is derived directly from the authoritative NFHL web services provided by FEMA. This map was exported on **4/16/2026 at 5:40 PM** and does not reflect changes or amendments subsequent to this date and time. The NFHL and effective information may change or become superseded by new data over time.

This map image is void if the one or more of the following map elements do not appear: basemap imagery, flood zone labels, legend, scale bar, map creation date, community identifiers, FIRM panel number, and FIRM effective date. Map images for unmapped and unmodernized areas cannot be used for regulatory purposes.



HALEY WARD

**INSPECTION & LONG-TERM MAINTENANCE PLAN FOR
RESIDENTIAL DEVELOPMENT**

**20 Central Avenue
PORTSMOUTH, NH**

Introduction

The intent of this plan is to provide Copley Properties (herein referred to as the "Owner") with a list of procedures that document the inspection and maintenance requirements of the stormwater management system for proposed development at 20 Central Avenue. Specifically, the proposed roof Drip Strip Filter Systems, Rain Gardens, and the stormwater Catch Basins (collectively referred to as the "Stormwater Management System"). The contact information for the owner shall be kept current, and if there is a change of ownership of the property this plan must be transferred to the new owner.

The following inspection and maintenance program is necessary to keep the stormwater management system functioning properly and will help maintain a high quality of stormwater runoff to minimize potential environmental impacts. By following the enclosed procedures, the owner will be able to maintain the functional design of the stormwater management system and maximize its ability to remove sediment and other contaminants from site generated stormwater runoff.

Construction Inspections

During the construction period, inspections shall be conducted at least once every seven (7) calendar days or once every 14 calendar days and within 24 hours of the end of a storm event of 0.5 inch or greater.

Annual Report

Following construction, the owner shall prepare an annual Inspection & Maintenance Report. The report shall include a summary of the system's maintenance and repair by transmission of the Inspection & Maintenance Log and other information as required. A copy of the report shall be delivered annually to the Portsmouth DPW, if required.

Inspection & Maintenance Checklist/Log

The following pages contain the Stormwater Management System Inspection & Maintenance Requirements and a blank copy of the Stormwater Management System Inspection & Maintenance Log. These forms are provided to the owner as a guideline for performing the inspection and maintenance of the Stormwater Management System. This is a guideline and should be periodically reviewed for conformance with current practice and standards.

Stormwater Management System Components

The Stormwater Management System is designed to mitigate the quality of site-generated stormwater runoff. As a result, the design includes the following elements:

Non-Structural BMPs

Non-Structural best management practices (BMP's) include temporary and permanent measures that typically require less labor and capital inputs and are intended to provide protection against erosion of soils. Examples of non-structural BMP's on this project may include but are not limited to:

- Dust control
- Sediment barriers
- Stabilized construction entrance
- Catch basin basket
- Dewatering control

Structural BMPs

Structural BMPs are more labor and capital-intensive structures or installations that require more specialized personnel to install. Examples on this project include but are not limited to:

- Roof Drip Strip Filter System
- Closed Drainage System

Inspection and Maintenance Requirements

The following summarizes the inspection and maintenance requirements for the various BMP's that may be found on this project.

1. **Roof Drip Strip Filter:** Inspections and maintenance of roof dripline filters shall occur annually. Inspect and remove any debris within the reservoir layer. Renew basin media if filter fails to drain within 72 hours after a 1-inch rainfall event.
2. **Storm Drains:** Monitor accumulation of debris in drainage structures monthly or after significant rain events. Remove sediments when they accumulate within the outlet pipe. During construction, maintain inlet protection until all areas have been stabilized. Prior to the end of construction, inspect the drains and basins for accumulations and remove and clean by jet- vacuuming.
3. **Rain Garden:** After installation of the rain garden, perform the following inspections on a monthly basis:
 - a. Monitor for excessive or concentrated accumulations of debris, or excessive erosion below the various pipe inlets. Remove debris as required and replace or add inlet fabric strips or rip rap stones.
 - b. Monitor the outflow for problems with erosion. Repair as required.
 - c. After significant rainfalls, monitor rain garden surfaces for ponding of water. If water remains flooded over the surface 24 hours after a 1" rainfall, then investigate the cause, if not related to overflow blockage, then excavate and replace filter media.
 - d. Monitor vegetation on rain garden and replace dead or dying vegetation as required.
 - e. Monitor rain garden for rodent borrows and repair as required; remove persistent occupiers.
 - f. Monitor side slopes of rain garden for damage or erosion—repair, as necessary.

Pollution Prevention

The following pollution prevention activities shall be undertaken to minimize potential impacts on stormwater runoff quality. The Contractor is responsible for all activities during construction. The Owner is responsible thereafter.

Spill Procedures

Any discharge of waste oil or other pollutant shall be reported immediately to the New Hampshire Department of Environmental Services (NHDES). The Contractor/Owner will be responsible for any incident of groundwater contamination resulting from the improper discharge of pollutants to the stormwater

system and may be required by NHDES to remediate incidents that may impact groundwater quality. If the property ownership is transferred, the new owner will be informed of the legal responsibilities associated with operation of the stormwater system, as indicated above.

Sanitary Facilities

Sanitary facilities shall be provided during all phases of construction.

Material Storage

The contractors are required to remove trash from the site. Hazardous material storage is prohibited. Salt and other de-icing materials must remain under covered storage. Salt storage areas shall be covered using permanent or semi-permanent measures and loading/offloading areas shall be located and designed to not drain directly to receiving waters and be maintained with good housekeeping measures in accordance with NHDES guidance documents. Snow will not be stored onsite – it will be removed from the site by a licensed contractor as needed. There are no wetlands, waterbodies, or other protected natural resources directly adjacent to the development area. Down-gradient stormwater structures will be protected as outlined in this document.

Material Disposal

All waste material, trash, sediment, and debris shall be removed from the site and disposed of in accordance with applicable local, state, and federal guidelines and regulations. Removed sediments shall be if necessary dewatered prior to disposal.

CATCH BASIN BASKET CONSTRUCTION MAINTENANCE SHEET

INSPECTION REQUIREMENTS		
ACTION TAKEN	FREQUENCY	MAINTENANCE REQUIREMENTS
-Check for damage to basket -Remove sediment from basket	Within 24 hours of rainfall, Daily during extended rainfall	<i>-Repair basket as necessary to prevent particles from reaching drainage system, or to prevent flooding.</i> <i>-Empty basket after every storm, or if clogged.</i>

MAINTENANCE LOG	
PROJECT NAME	
INSPECTOR NAME	INSPECTOR CONTACT INFO
DATE OF INSPECTION	REASON FOR INSPECTION <input type="checkbox"/> LARGE STORM EVENT <input type="checkbox"/> PERIODIC CHECK-IN
IS CORRECTIVE ACTION NEEDED? <input type="checkbox"/> YES <input type="checkbox"/> NO	DESCRIBE ANY PROBLEMS, NEEDED MAINTENANCE
DATE OF MAINTENANCE	PERFORMED BY
NOTES	

CLOSED DRAINAGE STRUCTURE LONG-TERM MAINTENANCE SHEET

INSPECTION REQUIREMENTS		
ACTION TAKEN	FREQUENCY	MAINTENANCE REQUIREMENTS
<ul style="list-style-type: none"> -Outlet Control Structures -Drain Manholes -Catch Basins 	Every other Month	<ul style="list-style-type: none"> <i>Check for erosion or short-circuiting</i> <i>Check for sediment accumulation</i> <i>Check for floatable contaminants</i>
<ul style="list-style-type: none"> -Drainage Pipes 	1 time per 2 years	<ul style="list-style-type: none"> <i>Check for sediment accumulation/clogging, or soiled runoff.</i> <i>Check for erosion at outlets.</i>

MAINTENANCE LOG	
PROJECT NAME	
INSPECTOR NAME	INSPECTOR CONTACT INFO
DATE OF INSPECTION	REASON FOR INSPECTION <input type="checkbox"/> LARGE STORM EVENT <input type="checkbox"/> PERIODIC CHECK-IN
IS CORRECTIVE ACTION NEEDED? <input type="checkbox"/> YES <input type="checkbox"/> NO	DESCRIBE ANY PROBLEMS, NEEDED MAINTENANCE
DATE OF MAINTENANCE	PERFORMED BY
NOTES	

STABILIZED CONSTRUCTION ENTRANCE CONSTRUCTION MAINTENANCE SHEET

INSPECTION REQUIREMENTS		
ACTION TAKEN	FREQUENCY	MAINTENANCE REQUIREMENTS
ENTRANCE SURFACE <i>-Check for sediment accumulation/clogging of stone</i> <i>-Check Vegetative filter strips</i>	After heavy rains, as necessary	<i>-Top dress pad with new stone.</i> <i>-Replace stone completely if completely clogged.</i> <i>-Maintain vigorous stand of vegetation.</i>
WASHING FACILITIES (if applicable) <i>-Monitor Sediment Accumulation</i>	As often as necessary	<i>-Remove Sediments from traps.</i>

MAINTENANCE LOG	
PROJECT NAME	
INSPECTOR NAME	INSPECTOR CONTACT INFO
DATE OF INSPECTION	REASON FOR INSPECTION <input type="checkbox"/> LARGE STORM EVENT <input type="checkbox"/> PERIODIC CHECK-IN
IS CORRECTIVE ACTION NEEDED? <input type="checkbox"/> YES <input type="checkbox"/> NO	DESCRIBE ANY PROBLEMS, NEEDED MAINTENANCE
DATE OF MAINTENANCE	PERFORMED BY
NOTES	

Methods for Disposing Non-Native Invasive Plants

Prepared by the Invasives Species Outreach Group, volunteers interested in helping people control invasive plants. Assistance provided by the Piscataquog Land Conservancy and the NH Invasives Species Committee. Edited by Karen Bennett, Extension Forestry Professor and Specialist.

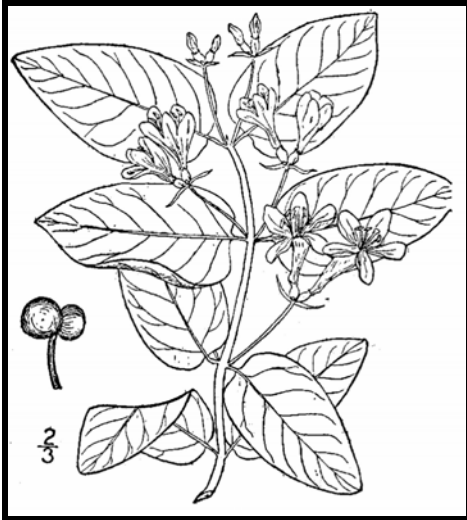

Tatarian honeysuckle

Lonicera tatarica

USDA-NRCS PLANTS Database / Britton, N.L., and A. Brown. 1913. *An illustrated flora of the northern United States, Canada and the British Possessions*. Vol. 3: 282.

Non-native invasive plants crowd out natives in natural and managed landscapes. They cost taxpayers billions of dollars each year from lost agricultural and forest crops, decreased biodiversity, impacts to natural resources and the environment, and the cost to control and eradicate them.

Invasive plants grow well even in less than desirable conditions such as sandy soils along roadsides, shaded wooded areas, and in wetlands. In ideal conditions, they grow and spread even faster. There are many ways to remove these non-native invasives, but once removed, care is needed to dispose the removed plant material so the plants don't grow where disposed.

Knowing how a particular plant reproduces indicates its method of spread and helps determine

the appropriate disposal method. Most are spread by seed and are dispersed by wind, water, animals, or people. Some reproduce by vegetative means from pieces of stems or roots forming new plants. Others spread through both seed and vegetative means.

Because movement and disposal of viable plant parts is restricted (see NH Regulations), viable invasive parts can't be brought to most transfer stations in the state. Check with your transfer station to see if there is an approved, designated area for invasives disposal. This fact sheet gives recommendations for rendering plant parts non-viable.

Control of invasives is beyond the scope of this fact sheet. For information about control visit www.nhinvasives.org or contact your UNH Cooperative Extension office.

New Hampshire Regulations

Prohibited invasive species shall only be disposed of in a manner that renders them nonliving and nonviable. (Agr. 3802.04)

No person shall collect, transport, import, export, move, buy, sell, distribute, propagate or transplant any living and viable portion of any plant species, which includes all of their cultivars and varieties, listed in Table 3800.1 of the New Hampshire prohibited invasive species list. (Agr. 3802.01)

How and When to Dispose of Invasives?

To prevent seed from spreading remove invasive plants before seeds are set (produced). Some plants continue to grow, flower and set seed even after pulling or cutting. Seeds can remain viable in the ground for many years. If the plant has flowers or seeds, place the flowers and seeds in a heavy plastic bag “head first” at the weeding site and transport to the disposal site. The following are general descriptions of disposal methods. See the chart for recommendations by species.

Burning: Large woody branches and trunks can be used as firewood or burned in piles. For outside burning, a written fire permit from the local forest fire warden is required unless the ground is covered in snow. Brush larger than 5 inches in diameter can't be burned. Invasive plants with easily airborne seeds like black swallow-wort with mature seed pods (indicated by their brown color) shouldn't be burned as the seeds may disperse by the hot air created by the fire.

Bagging (solarization): Use this technique with softer-tissue plants. Use heavy black or clear plastic bags (contractor grade), making sure that no parts of the plants poke through. Allow the bags to sit in the sun for several weeks and on dark pavement for the best effect.

Tarping and Drying: Pile material on a sheet of plastic and cover with a tarp, fastening the tarp to the ground and monitoring it for escapes. Let the material dry for several weeks, or until it is clearly nonviable.

Chipping: Use this method for woody plants that don't reproduce vegetatively.

Burying: This is risky, but can be done with watchful diligence. Lay thick plastic in a deep pit before placing the cut up plant material in the hole. Place the material away from the edge of the plastic before covering it with more heavy plastic. Eliminate as much air as possible and toss in soil to weight down the material in the pit. Note that the top of the buried material should be at least three feet underground. Japanese knotweed should be at least 5 feet underground!

Drowning: Fill a large barrel with water and place soft-tissue plants in the water. Check after a few weeks and look for rotted plant material (roots, stems, leaves, flowers). Well-rotted plant material may be composted. A word of caution- seeds may still be viable after using this method. Do this before seeds are set. This method isn't used often. Be prepared for an awful stink!

Composting: Invasive plants can take root in compost. Don't compost any invasives unless you know there is no viable (living) plant material left. Use one of the above techniques (bagging, tarping, drying, chipping, or drowning) to render the plants nonviable before composting. Closely examine the plant before composting and avoid composting seeds.





Japanese knotweed
Polygonum cuspidatum
USDA-NRCS PLANTS Database /
Britton, N.L., and A. Brown. 1913. *An illustrated flora of the northern United States, Canada and the British Possessions*. Vol. 1: 676.

Be diligent looking for seedlings for years in areas where removal and disposal took place.

Suggested Disposal Methods for Non-Native Invasive Plants

This table provides information concerning the disposal of removed invasive plant material. If the infestation is treated with herbicide and left in place, these guidelines don't apply. Don't bring invasives to a local transfer station, unless there is a designated area for their disposal, or they have been rendered non-viable. This listing includes wetland and upland plants from the New Hampshire Prohibited Invasive Species List. The disposal of aquatic plants isn't addressed.

Woody Plants	Method of Reproducing	Methods of Disposal
Norway maple <i>(Acer platanoides)</i> European barberry <i>(Berberis vulgaris)</i> Japanese barberry <i>(Berberis thunbergii)</i> autumn olive <i>(Elaeagnus umbellata)</i> burning bush <i>(Euonymus alatus)</i> Morrow's honeysuckle <i>(Lonicera morrowii)</i> Tatarian honeysuckle <i>(Lonicera tatarica)</i> showy bush honeysuckle <i>(Lonicera x bella)</i> common buckthorn <i>(Rhamnus cathartica)</i> glossy buckthorn <i>(Frangula alnus)</i>		<p>Prior to fruit/seed ripening</p> <p>Seedlings and small plants</p> <ul style="list-style-type: none"> ▪ Pull or cut and leave on site with roots exposed. No special care needed. <p>Larger plants</p> <ul style="list-style-type: none"> ▪ Use as firewood. ▪ Make a brush pile. ▪ Chip. ▪ Burn.
		<p>After fruit/seed is ripe</p> <p>Don't remove from site.</p> <ul style="list-style-type: none"> ▪ Burn. ▪ Make a covered brush pile. ▪ Chip once all fruit has dropped from branches. ▪ Leave resulting chips on site and monitor.
oriental bittersweet <i>(Celastrus orbiculatus)</i> multiflora rose <i>(Rosa multiflora)</i>		<p>Prior to fruit/seed ripening</p> <p>Seedlings and small plants</p> <ul style="list-style-type: none"> ▪ Pull or cut and leave on site with roots exposed. No special care needed. <p>Larger plants</p> <ul style="list-style-type: none"> ▪ Make a brush pile. ▪ Burn.
		<p>After fruit/seed is ripe</p> <p>Don't remove from site.</p> <ul style="list-style-type: none"> ▪ Burn. ▪ Make a covered brush pile. ▪ Chip – only after material has fully dried (1 year) and all fruit has dropped from branches. Leave resulting chips on site and monitor.

Non-Woody Plants	Method of Reproducing	Methods of Disposal
<p>garlic mustard (<i>Alliaria petiolata</i>)</p> <p>spotted knapweed (<i>Centaurea maculosa</i>)</p> <ul style="list-style-type: none"> ▪ Sap of related knapweed can cause skin irritation and tumors. Wear gloves when handling. <p>black swallow-wort (<i>Cynanchum nigrum</i>)</p> <ul style="list-style-type: none"> ▪ May cause skin rash. Wear gloves and long sleeves when handling. <p>pale swallow-wort (<i>Cynanchum rossicum</i>)</p> <p>giant hogweed (<i>Heracleum mantegazzianum</i>)</p> <ul style="list-style-type: none"> ▪ Can cause major skin rash. Wear gloves and long sleeves when handling. <p>dame's rocket (<i>Hesperis matronalis</i>)</p> <p>perennial pepperweed (<i>Lepidium latifolium</i>)</p> <p>purple loosestrife (<i>Lythrum salicaria</i>)</p> <p>Japanese stilt grass (<i>Microstegium vimineum</i>)</p> <p>mile-a-minute weed (<i>Polygonum perfoliatum</i>)</p>	<p>Fruits and Seeds</p> 	<p>Prior to flowering</p> <p>Depends on scale of infestation</p> <p>Small infestation</p> <ul style="list-style-type: none"> ▪ Pull or cut plant and leave on site with roots exposed. <p>Large infestation</p> <ul style="list-style-type: none"> ▪ Pull or cut plant and pile. (You can pile onto or cover with plastic sheeting). ▪ Monitor. Remove any re-sprouting material. <hr/> <p>During and following flowering</p> <p>Do nothing until the following year or remove flowering heads and bag and let rot.</p> <p>Small infestation</p> <ul style="list-style-type: none"> ▪ Pull or cut plant and leave on site with roots exposed. <p>Large infestation</p> <ul style="list-style-type: none"> ▪ Pull or cut plant and pile remaining material. (You can pile onto plastic or cover with plastic sheeting). ▪ Monitor. Remove any re-sprouting material.
<p>common reed (<i>Phragmites australis</i>)</p> <p>Japanese knotweed (<i>Polygonum cuspidatum</i>)</p> <p>Bohemian knotweed (<i>Polygonum x bohemicum</i>)</p>	<p>Fruits, Seeds, Plant Fragments</p> <p>Primary means of spread in these species is by plant parts. Although all care should be given to preventing the dispersal of seed during control activities, the presence of seed doesn't materially influence disposal activities.</p>	<p>Small infestation</p> <ul style="list-style-type: none"> ▪ Bag all plant material and let rot. ▪ Never pile and use resulting material as compost. ▪ Burn. <p>Large infestation</p> <ul style="list-style-type: none"> ▪ Remove material to unsuitable habitat (dry, hot and sunny or dry and shaded location) and scatter or pile. ▪ Monitor and remove any sprouting material. ▪ Pile, let dry, and burn.

January 2010

UNH Cooperative Extension programs and policies are consistent with pertinent Federal and State laws and regulations, and prohibits discrimination in its programs, activities and employment on the basis of race, color, national origin, gender, religion, age, disability, political beliefs, sex, sexual orientation, or veteran's, marital or family status. College of Life Sciences and Agriculture, County Governments, NH Dept. of Resources and Economic Development, Division of Forests and Lands, NH Fish and Game ,and U.S. Dept. of Agriculture cooperating.



HALEY WARD

**INSPECTION & LONG-TERM MAINTENANCE PLAN FOR
RESIDENTIAL DEVELOPMENT**

**20 Central Avenue
PORTSMOUTH, NH**

Introduction

The intent of this plan is to provide Copley Properties (herein referred to as the "Owner") with a list of procedures that document the inspection and maintenance requirements of the stormwater management system for proposed development at 20 Central Avenue. Specifically, the proposed roof Drip Strip Filter Systems, Rain Gardens, and the stormwater Catch Basins (collectively referred to as the "Stormwater Management System"). The contact information for the owner shall be kept current, and if there is a change of ownership of the property this plan must be transferred to the new owner.

The following inspection and maintenance program is necessary to keep the stormwater management system functioning properly and will help maintain a high quality of stormwater runoff to minimize potential environmental impacts. By following the enclosed procedures, the owner will be able to maintain the functional design of the stormwater management system and maximize its ability to remove sediment and other contaminants from site generated stormwater runoff.

Construction Inspections

During the construction period, inspections shall be conducted at least once every seven (7) calendar days or once every 14 calendar days and within 24 hours of the end of a storm event of 0.5 inch or greater.

Annual Report

Following construction, the owner shall prepare an annual Inspection & Maintenance Report. The report shall include a summary of the system's maintenance and repair by transmission of the Inspection & Maintenance Log and other information as required. A copy of the report shall be delivered annually to the Portsmouth DPW, if required.

Inspection & Maintenance Checklist/Log

The following pages contain the Stormwater Management System Inspection & Maintenance Requirements and a blank copy of the Stormwater Management System Inspection & Maintenance Log. These forms are provided to the owner as a guideline for performing the inspection and maintenance of the Stormwater Management System. This is a guideline and should be periodically reviewed for conformance with current practice and standards.

Stormwater Management System Components

The Stormwater Management System is designed to mitigate the quality of site-generated stormwater runoff. As a result, the design includes the following elements:

Non-Structural BMPs

Non-Structural best management practices (BMP's) include temporary and permanent measures that typically require less labor and capital inputs and are intended to provide protection against erosion of soils. Examples of non-structural BMP's on this project may include but are not limited to:

- Dust control
- Sediment barriers
- Stabilized construction entrance
- Catch basin basket
- Dewatering control

Structural BMPs

Structural BMPs are more labor and capital-intensive structures or installations that require more specialized personnel to install. Examples on this project include but are not limited to:

- Roof Drip Strip Filter System
- Closed Drainage System

Inspection and Maintenance Requirements

The following summarizes the inspection and maintenance requirements for the various BMP's that may be found on this project.

1. **Roof Drip Strip Filter:** Inspections and maintenance of roof dripline filters shall occur annually. Inspect and remove any debris within the reservoir layer. Renew basin media if filter fails to drain within 72 hours after a 1-inch rainfall event.
2. **Storm Drains:** Monitor accumulation of debris in drainage structures monthly or after significant rain events. Remove sediments when they accumulate within the outlet pipe. During construction, maintain inlet protection until all areas have been stabilized. Prior to the end of construction, inspect the drains and basins for accumulations and remove and clean by jet- vacuuming.
3. **Rain Garden:** After installation of the rain garden, perform the following inspections on a monthly basis:
 - a. Monitor for excessive or concentrated accumulations of debris, or excessive erosion below the various pipe inlets. Remove debris as required and replace or add inlet fabric strips or rip rap stones.
 - b. Monitor the outflow for problems with erosion. Repair as required.
 - c. After significant rainfalls, monitor rain garden surfaces for ponding of water. If water remains flooded over the surface 24 hours after a 1" rainfall, then investigate the cause, if not related to overflow blockage, then excavate and replace filter media.
 - d. Monitor vegetation on rain garden and replace dead or dying vegetation as required.
 - e. Monitor rain garden for rodent borrows and repair as required; remove persistent occupiers.
 - f. Monitor side slopes of rain garden for damage or erosion—repair, as necessary.

Pollution Prevention

The following pollution prevention activities shall be undertaken to minimize potential impacts on stormwater runoff quality. The Contractor is responsible for all activities during construction. The Owner is responsible thereafter.

Spill Procedures

Any discharge of waste oil or other pollutant shall be reported immediately to the New Hampshire Department of Environmental Services (NHDES). The Contractor/Owner will be responsible for any incident of groundwater contamination resulting from the improper discharge of pollutants to the stormwater

system and may be required by NHDES to remediate incidents that may impact groundwater quality. If the property ownership is transferred, the new owner will be informed of the legal responsibilities associated with operation of the stormwater system, as indicated above.

Sanitary Facilities

Sanitary facilities shall be provided during all phases of construction.

Material Storage

The contractors are required to remove trash from the site. Hazardous material storage is prohibited. Salt and other de-icing materials must remain under covered storage. Salt storage areas shall be covered using permanent or semi-permanent measures and loading/offloading areas shall be located and designed to not drain directly to receiving waters and be maintained with good housekeeping measures in accordance with NHDES guidance documents. Snow will not be stored onsite – it will be removed from the site by a licensed contractor as needed. There are no wetlands, waterbodies, or other protected natural resources directly adjacent to the development area. Down-gradient stormwater structures will be protected as outlined in this document.

Material Disposal

All waste material, trash, sediment, and debris shall be removed from the site and disposed of in accordance with applicable local, state, and federal guidelines and regulations. Removed sediments shall be if necessary dewatered prior to disposal.

CATCH BASIN BASKET CONSTRUCTION MAINTENANCE SHEET

INSPECTION REQUIREMENTS		
ACTION TAKEN	FREQUENCY	MAINTENANCE REQUIREMENTS
-Check for damage to basket -Remove sediment from basket	Within 24 hours of rainfall, Daily during extended rainfall	<i>-Repair basket as necessary to prevent particles from reaching drainage system, or to prevent flooding.</i> <i>-Empty basket after every storm, or if clogged.</i>

MAINTENANCE LOG	
PROJECT NAME	
INSPECTOR NAME	INSPECTOR CONTACT INFO
DATE OF INSPECTION	REASON FOR INSPECTION <input type="checkbox"/> LARGE STORM EVENT <input type="checkbox"/> PERIODIC CHECK-IN
IS CORRECTIVE ACTION NEEDED? <input type="checkbox"/> YES <input type="checkbox"/> NO	DESCRIBE ANY PROBLEMS, NEEDED MAINTENANCE
DATE OF MAINTENANCE	PERFORMED BY
NOTES	

CLOSED DRAINAGE STRUCTURE LONG-TERM MAINTENANCE SHEET

INSPECTION REQUIREMENTS		
ACTION TAKEN	FREQUENCY	MAINTENANCE REQUIREMENTS
<ul style="list-style-type: none"> -Outlet Control Structures -Drain Manholes -Catch Basins 	Every other Month	<ul style="list-style-type: none"> <i>Check for erosion or short-circuiting</i> <i>Check for sediment accumulation</i> <i>Check for floatable contaminants</i>
<ul style="list-style-type: none"> -Drainage Pipes 	1 time per 2 years	<ul style="list-style-type: none"> <i>Check for sediment accumulation/clogging, or soiled runoff.</i> <i>Check for erosion at outlets.</i>

MAINTENANCE LOG	
PROJECT NAME	
INSPECTOR NAME	INSPECTOR CONTACT INFO
DATE OF INSPECTION	REASON FOR INSPECTION <input type="checkbox"/> LARGE STORM EVENT <input type="checkbox"/> PERIODIC CHECK-IN
IS CORRECTIVE ACTION NEEDED? <input type="checkbox"/> YES <input type="checkbox"/> NO	DESCRIBE ANY PROBLEMS, NEEDED MAINTENANCE
DATE OF MAINTENANCE	PERFORMED BY
NOTES	

STABILIZED CONSTRUCTION ENTRANCE CONSTRUCTION MAINTENANCE SHEET

INSPECTION REQUIREMENTS		
ACTION TAKEN	FREQUENCY	MAINTENANCE REQUIREMENTS
ENTRANCE SURFACE <i>-Check for sediment accumulation/clogging of stone</i> <i>-Check Vegetative filter strips</i>	After heavy rains, as necessary	<i>-Top dress pad with new stone.</i> <i>-Replace stone completely if completely clogged.</i> <i>-Maintain vigorous stand of vegetation.</i>
WASHING FACILITIES (if applicable) <i>-Monitor Sediment Accumulation</i>	As often as necessary	<i>-Remove Sediments from traps.</i>

MAINTENANCE LOG	
PROJECT NAME	
INSPECTOR NAME	INSPECTOR CONTACT INFO
DATE OF INSPECTION	REASON FOR INSPECTION <input type="checkbox"/> LARGE STORM EVENT <input type="checkbox"/> PERIODIC CHECK-IN
IS CORRECTIVE ACTION NEEDED? <input type="checkbox"/> YES <input type="checkbox"/> NO	DESCRIBE ANY PROBLEMS, NEEDED MAINTENANCE
DATE OF MAINTENANCE	PERFORMED BY
NOTES	

Methods for Disposing Non-Native Invasive Plants

Prepared by the Invasives Species Outreach Group, volunteers interested in helping people control invasive plants. Assistance provided by the Piscataquog Land Conservancy and the NH Invasives Species Committee. Edited by Karen Bennett, Extension Forestry Professor and Specialist.

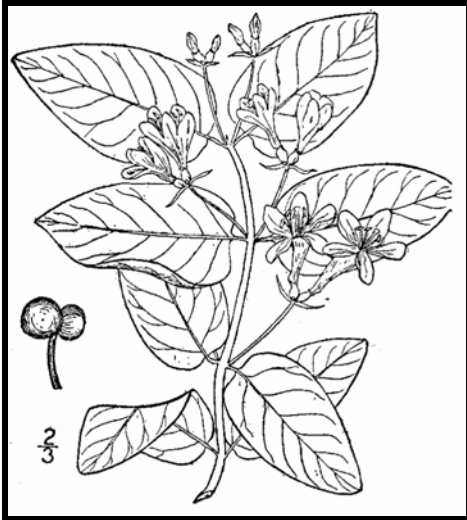

Tatarian honeysuckle

Lonicera tatarica

USDA-NRCS PLANTS Database / Britton, N.L., and A. Brown. 1913. *An illustrated flora of the northern United States, Canada and the British Possessions*. Vol. 3: 282.

Non-native invasive plants crowd out natives in natural and managed landscapes. They cost taxpayers billions of dollars each year from lost agricultural and forest crops, decreased biodiversity, impacts to natural resources and the environment, and the cost to control and eradicate them.

Invasive plants grow well even in less than desirable conditions such as sandy soils along roadsides, shaded wooded areas, and in wetlands. In ideal conditions, they grow and spread even faster. There are many ways to remove these non-native invasives, but once removed, care is needed to dispose the removed plant material so the plants don't grow where disposed.

Knowing how a particular plant reproduces indicates its method of spread and helps determine

the appropriate disposal method. Most are spread by seed and are dispersed by wind, water, animals, or people. Some reproduce by vegetative means from pieces of stems or roots forming new plants. Others spread through both seed and vegetative means.

Because movement and disposal of viable plant parts is restricted (see NH Regulations), viable invasive parts can't be brought to most transfer stations in the state. Check with your transfer station to see if there is an approved, designated area for invasives disposal. This fact sheet gives recommendations for rendering plant parts non-viable.

Control of invasives is beyond the scope of this fact sheet. For information about control visit www.nhinvasives.org or contact your UNH Cooperative Extension office.

New Hampshire Regulations

Prohibited invasive species shall only be disposed of in a manner that renders them nonliving and nonviable. (Agr. 3802.04)

No person shall collect, transport, import, export, move, buy, sell, distribute, propagate or transplant any living and viable portion of any plant species, which includes all of their cultivars and varieties, listed in Table 3800.1 of the New Hampshire prohibited invasive species list. (Agr 3802.01)

How and When to Dispose of Invasives?

To prevent seed from spreading remove invasive plants before seeds are set (produced). Some plants continue to grow, flower and set seed even after pulling or cutting. Seeds can remain viable in the ground for many years. If the plant has flowers or seeds, place the flowers and seeds in a heavy plastic bag “head first” at the weeding site and transport to the disposal site. The following are general descriptions of disposal methods. See the chart for recommendations by species.

Burning: Large woody branches and trunks can be used as firewood or burned in piles. For outside burning, a written fire permit from the local forest fire warden is required unless the ground is covered in snow. Brush larger than 5 inches in diameter can't be burned. Invasive plants with easily airborne seeds like black swallow-wort with mature seed pods (indicated by their brown color) shouldn't be burned as the seeds may disperse by the hot air created by the fire.

Bagging (solarization): Use this technique with softer-tissue plants. Use heavy black or clear plastic bags (contractor grade), making sure that no parts of the plants poke through. Allow the bags to sit in the sun for several weeks and on dark pavement for the best effect.

Tarpping and Drying: Pile material on a sheet of plastic and cover with a tarp, fastening the tarp to the ground and monitoring it for escapes. Let the material dry for several weeks, or until it is clearly nonviable.

Chipping: Use this method for woody plants that don't reproduce vegetatively.

Burying: This is risky, but can be done with watchful diligence. Lay thick plastic in a deep pit before placing the cut up plant material in the hole. Place the material away from the edge of the plastic before covering it with more heavy plastic. Eliminate as much air as possible and toss in soil to weight down the material in the pit. Note that the top of the buried material should be at least three feet underground. Japanese knotweed should be at least 5 feet underground!

Drowning: Fill a large barrel with water and place soft-tissue plants in the water. Check after a few weeks and look for rotted plant material (roots, stems, leaves, flowers). Well-rotted plant material may be composted. A word of caution- seeds may still be viable after using this method. Do this before seeds are set. This method isn't used often. Be prepared for an awful stink!

Composting: Invasive plants can take root in compost. Don't compost any invasives unless you know there is no viable (living) plant material left. Use one of the above techniques (bagging, tarping, drying, chipping, or drowning) to render the plants nonviable before composting. Closely examine the plant before composting and avoid composting seeds.





Japanese knotweed
Polygonum cuspidatum
USDA-NRCS PLANTS Database /
Britton, N.L., and A. Brown. 1913. *An illustrated flora of the northern United States, Canada and the British Possessions*. Vol. 1: 676.

Be diligent looking for seedlings for years in areas where removal and disposal took place.

Suggested Disposal Methods for Non-Native Invasive Plants

This table provides information concerning the disposal of removed invasive plant material. If the infestation is treated with herbicide and left in place, these guidelines don't apply. Don't bring invasives to a local transfer station, unless there is a designated area for their disposal, or they have been rendered non-viable. This listing includes wetland and upland plants from the New Hampshire Prohibited Invasive Species List. The disposal of aquatic plants isn't addressed.

Woody Plants	Method of Reproducing	Methods of Disposal
Norway maple <i>(Acer platanoides)</i> European barberry <i>(Berberis vulgaris)</i> Japanese barberry <i>(Berberis thunbergii)</i> autumn olive <i>(Elaeagnus umbellata)</i> burning bush <i>(Euonymus alatus)</i> Morrow's honeysuckle <i>(Lonicera morrowii)</i> Tatarian honeysuckle <i>(Lonicera tatarica)</i> showy bush honeysuckle <i>(Lonicera x bella)</i> common buckthorn <i>(Rhamnus cathartica)</i> glossy buckthorn <i>(Frangula alnus)</i>		<p>Prior to fruit/seed ripening</p> <p>Seedlings and small plants</p> <ul style="list-style-type: none"> ▪ Pull or cut and leave on site with roots exposed. No special care needed. <p>Larger plants</p> <ul style="list-style-type: none"> ▪ Use as firewood. ▪ Make a brush pile. ▪ Chip. ▪ Burn.
		<p>After fruit/seed is ripe</p> <p>Don't remove from site.</p> <ul style="list-style-type: none"> ▪ Burn. ▪ Make a covered brush pile. ▪ Chip once all fruit has dropped from branches. ▪ Leave resulting chips on site and monitor.
oriental bittersweet <i>(Celastrus orbiculatus)</i> multiflora rose <i>(Rosa multiflora)</i>		<p>Prior to fruit/seed ripening</p> <p>Seedlings and small plants</p> <ul style="list-style-type: none"> ▪ Pull or cut and leave on site with roots exposed. No special care needed. <p>Larger plants</p> <ul style="list-style-type: none"> ▪ Make a brush pile. ▪ Burn.
		<p>After fruit/seed is ripe</p> <p>Don't remove from site.</p> <ul style="list-style-type: none"> ▪ Burn. ▪ Make a covered brush pile. ▪ Chip – only after material has fully dried (1 year) and all fruit has dropped from branches. Leave resulting chips on site and monitor.

Non-Woody Plants	Method of Reproducing	Methods of Disposal
<p>garlic mustard (<i>Alliaria petiolata</i>)</p> <p>spotted knapweed (<i>Centaurea maculosa</i>)</p> <ul style="list-style-type: none"> ▪ Sap of related knapweed can cause skin irritation and tumors. Wear gloves when handling. <p>black swallow-wort (<i>Cynanchum nigrum</i>)</p> <ul style="list-style-type: none"> ▪ May cause skin rash. Wear gloves and long sleeves when handling. <p>pale swallow-wort (<i>Cynanchum rossicum</i>)</p> <p>giant hogweed (<i>Heracleum mantegazzianum</i>)</p> <ul style="list-style-type: none"> ▪ Can cause major skin rash. Wear gloves and long sleeves when handling. <p>dame's rocket (<i>Hesperis matronalis</i>)</p> <p>perennial pepperweed (<i>Lepidium latifolium</i>)</p> <p>purple loosestrife (<i>Lythrum salicaria</i>)</p> <p>Japanese stilt grass (<i>Microstegium vimineum</i>)</p> <p>mile-a-minute weed (<i>Polygonum perfoliatum</i>)</p>	<p>Fruits and Seeds</p> 	<p>Prior to flowering</p> <p>Depends on scale of infestation</p> <p>Small infestation</p> <ul style="list-style-type: none"> ▪ Pull or cut plant and leave on site with roots exposed. <p>Large infestation</p> <ul style="list-style-type: none"> ▪ Pull or cut plant and pile. (You can pile onto or cover with plastic sheeting). ▪ Monitor. Remove any re-sprouting material. <hr/> <p>During and following flowering</p> <p>Do nothing until the following year or remove flowering heads and bag and let rot.</p> <p>Small infestation</p> <ul style="list-style-type: none"> ▪ Pull or cut plant and leave on site with roots exposed. <p>Large infestation</p> <ul style="list-style-type: none"> ▪ Pull or cut plant and pile remaining material. (You can pile onto plastic or cover with plastic sheeting). ▪ Monitor. Remove any re-sprouting material.
<p>common reed (<i>Phragmites australis</i>)</p> <p>Japanese knotweed (<i>Polygonum cuspidatum</i>)</p> <p>Bohemian knotweed (<i>Polygonum x bohemicum</i>)</p>	<p>Fruits, Seeds, Plant Fragments</p> <p>Primary means of spread in these species is by plant parts. Although all care should be given to preventing the dispersal of seed during control activities, the presence of seed doesn't materially influence disposal activities.</p>	<p>Small infestation</p> <ul style="list-style-type: none"> ▪ Bag all plant material and let rot. ▪ Never pile and use resulting material as compost. ▪ Burn. <p>Large infestation</p> <ul style="list-style-type: none"> ▪ Remove material to unsuitable habitat (dry, hot and sunny or dry and shaded location) and scatter or pile. ▪ Monitor and remove any sprouting material. ▪ Pile, let dry, and burn.

January 2010

UNH Cooperative Extension programs and policies are consistent with pertinent Federal and State laws and regulations, and prohibits discrimination in its programs, activities and employment on the basis of race, color, national origin, gender, religion, age, disability, political beliefs, sex, sexual orientation, or veteran's, marital or family status. College of Life Sciences and Agriculture, County Governments, NH Dept. of Resources and Economic Development, Division of Forests and Lands, NH Fish and Game ,and U.S. Dept. of Agriculture cooperating.

COPLEY PROPERTIES, LLC PROPOSED 3 LOT SUBDIVISION

20 CENTRAL AVENUE, PORTSMOUTH NH

PROJECT INFORMATION

CIVIL ENGINEER
HALEY WARD, INC.
ATTN: SHAWN TOBEY, PE.
200 GRIFFIN ROAD, UNIT 14
PORTSMOUTH, NH 03801
T: 603.430.9282

OWNER
MARISSA VALVERDE
20 CENTRAL AVENUE
PORTSMOUTH, NH 03801

SURVEYOR
HALEY WARD, INC.
ATTN: PHILLIP YETMAN, PLS
200 GRIFFIN ROAD, UNIT 14
PORTSMOUTH, NH 03801
T: 603.430.9282

APPLICANT
COPLEY PROPERTIES, LLC
94 PORTSMOUTH AVENUE
STRATHAM, NH 03885

ACOUSTIC STUDY
REUTER ASSOCIATES, LLC
10 VAUGHAN MALL, SUITE 201A
PORTSMOUTH, NH 03801
T: 603.430.2081

ARCHITECT
ART FORM ARCHITECTURE, LLC
ATTN: HOLLY SPINNEY
PO BOX 535
NORTH HAMPTON, NH 03862
T: 603.431.9559

UTILITY PROVIDERS

WATER & SEWER
CITY OF PORTSMOUTH DEPT. OF
PUBLIC WORKS
ATTN: DOUG SPARKS
680 PEVERLY HILL ROAD
PORTSMOUTH, NH 03801
T: 603.427.1530

ELECTRIC
EVERSOURCE
ATTN: NICHOLAS KOSKO
1700 LAFAYETTE ROAD
PORTSMOUTH, NH 03801
T: 603.436.7708, EXT. 3327565

CABLE
XFINITY BY COMCAST
ATTN: MIKE COLLINS
180 GREENLEAF AVENUE
PORTSMOUTH, NH 03801
T: 603.266.2278

COMMUNICATIONS
CONSOLIDATED COMMUNICATIONS
ATTN: BENJAMIN WILLS
1575 GREENLAND ROAD
GREENLAND, NH 03840
T: 603.427.5525

NATURAL GAS
UNITIL
ATTN: DAVE BEAULIEU
325 WEST ROAD
PORTSMOUTH, NH 03801
T: 603.294.5144

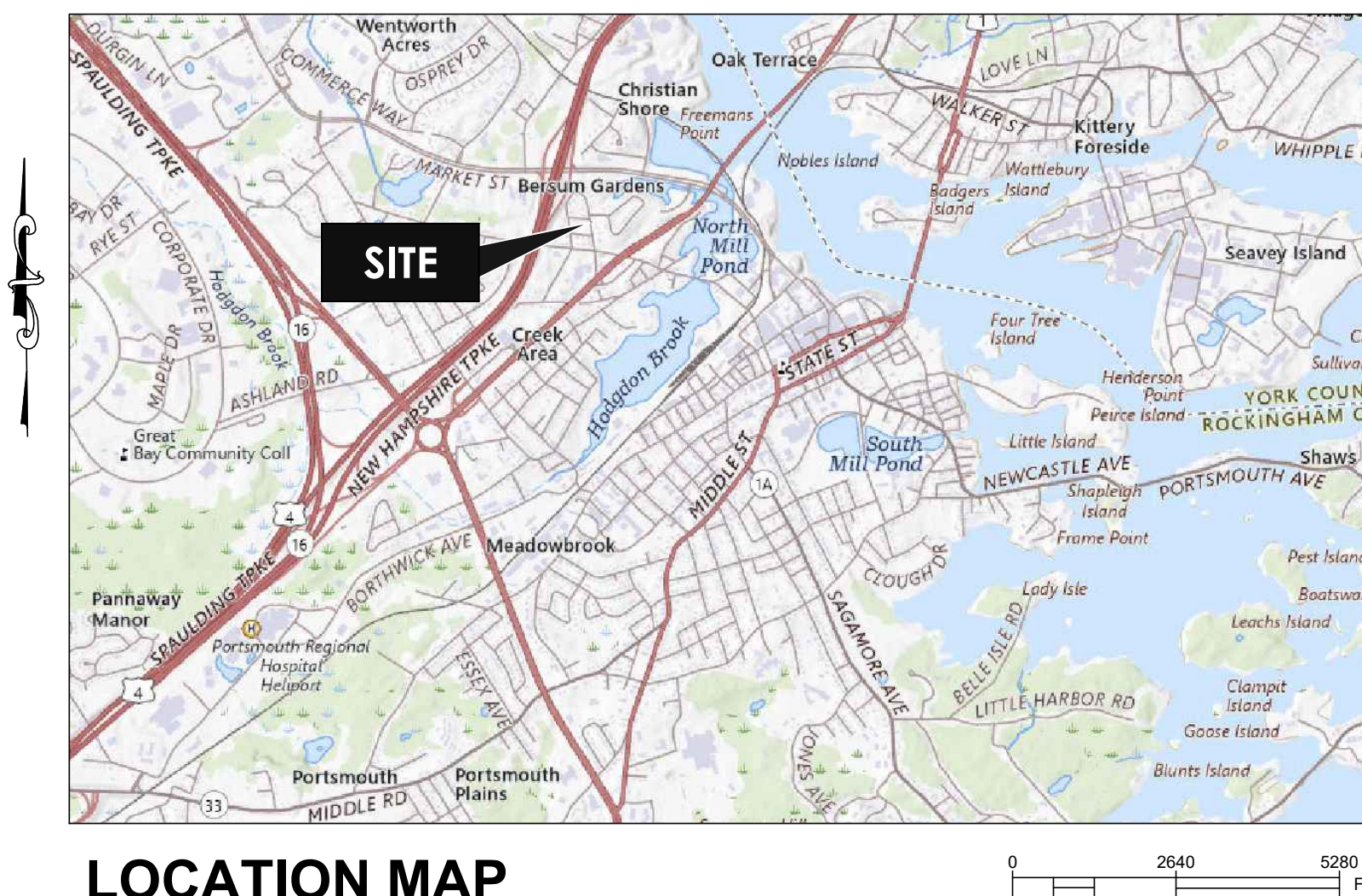

LOCATION MAP

INDEX OF DRAWINGS

C000	COVER SHEET
C001	GENERAL NOTES, LEGEND & ABBREVIATIONS
-	SUBDIVISION PLAN
V101	EXISTING CONDITIONS PLAN
C101	DEMOLITION PLAN
C102	SITE LAYOUT & UTILITY PLAN
C103	GRADING & DRAINAGE PLAN
C501	SITE DETAILS
C502	SITE DETAILS
C701	PRE-DEVELOPMENT HYDROLOGY PLAN
C702	POST-DEVELOPMENT HYDROLOGY PLAN
L101	LANDSCAPE PLAN

PERMITS & APPROVALS	PERMIT #	DATE
CITY OF PORTSMOUTH TAC REVIEW	TBD	PENDING
CITY OF PORTSMOUTH SITE PLAN/SUBDIVISION	TBD	PENDING
CITY OF PORTSMOUTH CONDITIONAL USE PERMIT	TBD	PENDING

**ISSUED FOR TAC REVIEW
JUNE 22, 2026**



HALEY WARD

www.haleyward.com

CONSTRUCTION NOTES

CONSTRUCTION SEQUENCE

- DO NOT BEGIN CONSTRUCTION UNTIL ALL LOCAL, STATE AND FEDERAL PERMITS HAVE BEEN APPLIED FOR AND RECEIVED.
- INSTALL SILT SOXX TO CONTROL EROSION AND SEDIMENTATION PRIOR TO ANY EARTH MOVING ACTIVITIES.
- REMOVE EXISTING BUILDINGS AND SITE FEATURES AS REQUIRED.
- CONSTRUCT STABILIZED CONSTRUCTION ENTRANCE.
- CUT AND REMOVE ALL TREES, SHRUBS, AND OTHER DEBRIS AS REQUIRED.
- STRIP AND STOCKPILE LOAM FROM SITE. STOCKPILES SHALL BE SURROUNDED WITH SILT SOXX TO CONTROL SEDIMENT RUN OFF.
- ROUGH GRADE SITE AND CONSTRUCT DRAINAGE STRUCTURES. INSTALL AND MAINTAIN EROSION CONTROL DEVICES AS SHOWN ON THE PLANS. ALL PERMANENT DITCHES, AND SWALES SHALL BE STABILIZED PRIOR TO DIRECTING RUNOFF TO THEM. CONSTRUCT BUILDING FOUNDATIONS.
- LOAM AND SEED DISTURBED AREAS. CUT AND FILL SLOPES SHALL BE SEEDED IMMEDIATELY AFTER THEIR CONSTRUCTION.
- CONSTRUCT UTILITIES, BUILDINGS AND PAVEMENT BASE COURSE.
- PLANT LANDSCAPING.
- CONSTRUCT PAVEMENT WEARING COURSE.
- REMOVE TRAPPED SEDIMENTS FROM COLLECTION DEVICES AS APPROPRIATE, AND THEN REMOVE TEMPORARY EROSION CONTROL MEASURES.

PROJECT DESCRIPTION

- THE PROJECT CONSISTS OF SUBDIVIDING A SINGLE LOT INTO THREE NEW LOTS, DEMOLISHING THE EXISTING BUILDINGS AND RELATED STRUCTURES, AND CONSTRUCTING THREE SINGLE FAMILY HOMES WITH DRIVEWAYS AND ASSOCIATED SITE IMPROVEMENTS.
- THE TOTAL AREA TO BE DISTURBED IS APPROXIMATELY 25,500 SQUARE FEET.
- THE STORMWATER RUNOFF FROM THE SITE WILL FOLLOW EXISTING PATTERNS AND DISCHARGE OFFSITE TO THE INTO THE CITY STORMWATER SYSTEM IN CENTRAL AVENUE AND BEECHWOOD STREET.

GENERAL CONSTRUCTION NOTES

- THE EROSION CONTROL PROCEDURES SHALL CONFORM TO SECTION 645 OF THE "STANDARD SPECIFICATION FOR ROAD AND BRIDGE CONSTRUCTION" OF THE NHDOT, AND "STORM WATER MANAGEMENT AND EROSION AND SEDIMENT CONTROL HANDBOOK FOR URBAN AND SUBURBAN AREAS IN NEW HAMPSHIRE". THE PROJECT IS TO BE MANAGED IN A MANNER THAT MEETS THE REQUIREMENTS AND INTENT OF RSA 430:53 AND CHAPTER AGR 3800 RELATIVE TO INVASIVE SPECIES.
- DURING CONSTRUCTION AND THEREAFTER, EROSION CONTROL MEASURES ARE TO BE IMPLEMENTED AS NOTED. THE SMALLEST PRACTICAL AREA OF LAND SHOULD BE EXPOSED AT ANY ONE TIME DURING DEVELOPMENT. NO DISTURBED AREA SHALL BE LEFT UNSTABILIZED FOR MORE THAN 45 DAYS.
- ANY DISTURBED AREAS WHICH ARE TO BE LEFT TEMPORARILY, AND WHICH WILL BE REGRADED LATER DURING CONSTRUCTION SHALL BE MACHINE HAY MULCHED AND SEEDED WITH RYE GRASS TO PREVENT EROSION.
- THE PROJECT IS TO BE MANAGED IN A MANNER THAT MEETS THE REQUIREMENTS AND INTENT OF RSA 430:53 AND CHAPTER AGR 3800 RELATIVE TO INVASIVE SPECIES.
- DUST CONTROL MEASURES SHALL INCLUDE BUT ARE NOT LIMITED TO SPRINKLING WATER ON EXPOSED AREAS, COVERING LOADED DUMP TRUCKS LEAVING THE SITE, AND TEMPORARY MULCHING. DUST CONTROL MEASURES SHALL BE UTILIZED SO AS TO PREVENT THE MIGRATION OF DUST FROM THE SITE TO ADJUTING AREAS. IF TEMPORARY STABILIZATION PRACTICES, SUCH AS TEMPORARY VEGETATION AND MULCHING, DO NOT ADEQUATELY REDUCE DUST GENERATION, APPLICATION OF WATER OR CALCIUM CHLORIDE SHALL BE APPLIED IN ACCORDANCE WITH BEST MANAGEMENT PRACTICES.
- SILT/SOXX SHALL BE PERIODICALLY INSPECTED DURING THE LIFE OF THE PROJECT AND AFTER EACH STORM. ALL DAMAGED SILT/SOXX SHALL BE REPAIRED. SEDIMENT DEPOSITS SHALL PERIODICALLY BE REMOVED AND DISPOSED IN A SECURED LOCATION.
- ALL FILLS SHALL BE PLACED AND COMPACTED TO REDUCE EROSION, SLIPPAGE, SETTLEMENT, SUBSIDENCE OR OTHER RELATED PROBLEMS.
- ALL NON-STRUCTURAL, SITE-FILL SHALL BE PLACED AND COMPACTED TO 90% MODIFIED PROCTOR DENSITY IN LAYERS NOT EXCEEDING 18 INCHES IN THICKNESS UNLESS OTHERWISE NOTED.
- FROZEN MATERIAL OR SOFT, MUCKY OR HIGHLY COMPRESSIBLE MATERIAL, TRASH, WOODY DEBRIS, LEAVES, BRUSH OR ANY DELETERIOUS MATTER SHALL NOT BE INCORPORATED INTO FILLS.
- FILL MATERIAL SHALL NOT BE PLACED ON FROZEN FOUNDATION SUBGRADE.
- DURING CONSTRUCTION AND UNTIL ALL DEVELOPED AREAS ARE FULLY STABILIZED, ALL EROSION CONTROL MEASURES SHALL BE INSPECTED WEEKLY AND AFTER EACH ONE HALF INCH OF RAINFALL.
- THE CONTRACTOR SHALL MODIFY OR ADD EROSION CONTROL MEASURES AS NECESSARY TO ACCOMMODATE PROJECT CONSTRUCTION.
- ALL ROADWAYS AND PARKING AREAS SHALL BE STABILIZED WITHIN 72 HOURS OF ACHIEVING FINISHED GRADE. ALL CUT AND FILL SLOPES SHALL BE SEDED/LOAMED WITHIN 72 HOURS OF ACHIEVING FINISHED GRADE.
- AN AREA SHALL BE CONSIDERED STABLE IF ONE OF THE FOLLOWING HAS OCCURRED:
 - BASE COURSE GRAVELS HAVE BEEN INSTALLED ON AREAS TO BE PAVED
 - A MINIMUM OF 85% VEGETATED GROWTH HAS BEEN ESTABLISHED
 - A MINIMUM OF 3 INCHES OF NON-EROSIVE MATERIAL SUCH AS STONE OR RIPRAP HAS BEEN INSTALLED
 - EROSION CONTROL BLANKETS HAVE BEEN INSTALLED
 - IN AREAS TO BE PAVED, "STABLE" MEANS THAT BASE COURSE GRAVELS MEETING THE REQUIREMENTS OF NHDOT STANDARD FOR ROAD AND BRIDGE CONSTRUCTION, 2016, ITEM 304.2 HAVE BEEN INSTALLED.
- STABILIZATION SHALL BE INITIATED ON ALL LOAM STOCKPILES, AND DISTURBED AREAS, WHERE CONSTRUCTION ACTIVITY SHALL NOT OCCUR FOR MORE THAN TWENTY-ONE (21) CALENDAR DAYS BY THE FOURTEENTH (14TH) DAY AFTER CONSTRUCTION ACTIVITY HAS PERMANENTLY OR TEMPORARILY CEASED IN THAT AREA.
- STABILIZATION MEASURES TO BE USED INCLUDE:
 - TEMPORARY SEEDING;
 - MULCHING.
- ALL AREAS SHALL BE STABILIZED WITHIN 45 DAYS OF INITIAL DISTURBANCE.
- WHEN CONSTRUCTION ACTIVITY PERMANENTLY OR TEMPORARILY CEASES WITHIN 100 FEET OF NEARBY SURFACE WATERS OR DELINEATED WETLANDS, THE AREA SHALL BE STABILIZED WITHIN SEVEN (7) DAYS OR PRIOR TO A RAIN EVENT. ONCE CONSTRUCTION ACTIVITY CEASES PERMANENTLY IN THESE AREAS, SILT/SOXX, MULCH BERMS, HAY BALE BARRIERS AND ANY EARTHDIKES SHALL BE REMOVED ONCE PERMANENT MEASURES ARE ESTABLISHED.
- DURING CONSTRUCTION, RUNOFF WILL BE DIVERTED AROUND THE SITE WITH EARTH DIKES, PIPING OR STABILIZED CHANNELS WHERE POSSIBLE. SHEET RUNOFF FROM THE SITE WILL BE FILTERED THROUGH SILT/SOXX, MULCH BERMS, HAY BALE BARRIERS, OR SILT SOCKS. ALL STORM DRAIN BASIN INLETS SHALL BE PROVIDED WITH FLARED END SECTIONS AND TRASH RACKS. THE SITE SHALL BE STABILIZED FOR THE WINTER BY OCTOBER 15.

MAINTENANCE AND PROTECTION

- THE SILT/SOXX BARRIER SHALL BE CHECKED AFTER EACH RAINFALL AND AT LEAST DAILY DURING PROLONGED RAINFALL.
- SILT/SOXX SHALL BE REMOVED ONCE SITE IS STABILIZED, AND DISTURBED AREAS RESULTING FROM SILT/SOXX REMOVAL SHALL BE PERMANENTLY SEEDED.
- THE CATCH BASIN INLET BASKET SHALL BE INSPECTED WITHIN 24 HOURS AFTER EACH RAINFALL OR DAILY DURING EXTENDED PERIODS OF PRECIPITATION. REPAIRS SHALL BE MADE IMMEDIATELY, AS NECESSARY, TO PREVENT PARTICLES FROM REACHING THE DRAINAGE SYSTEM AND/OR CAUSING SURFACE FLOODING. SEDIMENT DEPOSITS SHALL BE REMOVED AFTER EACH STORM EVENT, OR MORE OFTEN IF THE FABRIC BECOMES CLOGGED.

WINTER NOTES

- ALL PROPOSED VEGETATED AREAS THAT DO NOT EXHIBIT A MINIMUM OF 85% VEGETATED GROWTH BY OCTOBER 15, OR WHICH ARE DISTURBED AFTER OCTOBER 15, SHALL BE STABILIZED BY SEEDING AND INSTALLING EROSION CONTROL BLANKETS ON SLOPES GREATER THAN 3:1, AND SEEDING AND PLACING 3 TO 4 TONS OF MULCH PER ACRE, SECURED WITH ANCHORED NETTING, ELSEWHERE. THE INSTALLATION OF EROSION CONTROL BLANKETS OR MULCH AND NETTING SHALL NOT OCCUR OVER ACCUMULATED SNOW OR ON FROZEN GROUND AND SHALL BE COMPLETED IN ADVANCE OF THAW OR SPRING MELT EVENTS.
- ALL DITCHES OR SWALES WHICH DO NOT EXHIBIT A MINIMUM OF 85 PERCENT VEGETATIVE GROWTH BY OCTOBER 15, OR WHICH ARE DISTURBED AFTER OCTOBER 15, SHALL BE STABILIZED TEMPORARILY WITH STONE OR EROSION CONTROL BLANKETS APPROPRIATE FOR THE DESIGN FLOW CONDITIONS.
- AFTER OCTOBER 15, INCOMPLETE ROAD OR PARKING SURFACES, WHERE WORK HAS STOPPED FOR THE WINTER SEASON, SHALL BE PROTECTED WITH A MINIMUM OF 3 INCHES OF CRUSHED GRAVEL PER NHDOT ITEM 304.3, OR IF CONSTRUCTION IS TO CONTINUE THROUGH THE WINTER SEASON BE CLEARED OF ANY ACCUMULATED SNOW AFTER EACH STORM EVENT.

STOCKPILES

- LOCATE STOCKPILES A MINIMUM OF 50 FEET AWAY FROM CATCH BASINS, SWALES, AND CULVERTS.
- ALL STOCKPILES SHOULD BE SURROUNDED WITH TEMPORARY EROSION CONTROL MEASURES PRIOR TO THE ONSET OF PRECIPITATION.
- PERIMETER BARRIERS SHOULD BE MAINTAINED AT ALL TIMES, AND ADJUSTED AS NEEDED TO ACCOMMODATE THE DELIVERY AND REMOVAL OF MATERIALS FROM THE STOCKPILE. THE INTEGRITY OF THE BARRIER SHOULD BE INSPECTED AT THE END OF EACH WORKING DAY.
- PROTECT ALL STOCKPILES FROM STORMWATER RUN-OFF USING TEMPORARY EROSION CONTROL MEASURES SUCH AS BERMS, SILT SOCK, OR OTHER APPROVED PRACTICE TO PREVENT MIGRATION OF MATERIAL BEYOND THE IMMEDIATE CONFINES OF THE STOCKPILES.

CONCRETE WASHOUT AREA

THE FOLLOWING ARE THE ONLY NON-STORMWATER DISCHARGES ALLOWED. ALL OTHER NON-STORMWATER DISCHARGES ARE PROHIBITED ON SITE:

- THE CONCRETE DELIVERY TRUCKS SHALL, WHENEVER POSSIBLE, USE WASHOUT FACILITIES AT THEIR OWN PLANT OR DISPATCH FACILITY;
- IF IT IS NECESSARY, SITE CONTRACTOR SHALL DESIGNATE SPECIFIC WASHOUT AREAS AND DESIGN FACILITIES TO HANDLE ANTICIPATED WASHOUT WATER;
- CONTRACTOR SHALL LOCATE WASHOUT AREAS AT LEAST 150 FEET AWAY FROM STORM DRAINS, SWALES AND SURFACE WATERS OR DELINEATED WETLANDS;
- INSPECT WASHOUT FACILITIES DAILY TO DETECT LEAKS OR TEARS AND TO IDENTIFY WHEN MATERIALS NEED TO BE REMOVED.

UTILITY NOTES

- SEE EXISTING CONDITIONS PLAN FOR BENCHMARK INFORMATION.
- COORDINATE ALL UTILITY WORK WITH APPROPRIATE UTILITY.
- SEE GRADING AND DRAINAGE PLAN FOR PROPOSED GRADING AND EROSION CONTROL MEASURES.
- ALL SEWER PIPE SHALL BE PVC SDR 35 UNLESS OTHERWISE STATED.
- ALL WORK WITHIN CITY R.O.W. SHALL BE COORDINATED WITH CITY OF PORTSMOUTH
- CONTRACTOR SHALL MAINTAIN UTILITY SERVICES TO ABUTTING PROPERTIES THROUGHOUT CONSTRUCTION.
- EXISTING UTILITIES TO BE REMOVED SHALL BE CAPPED AT THE MAIN AND MEET THE DEPARTMENT OF PUBLIC WORKS STANDARDS FOR CAPPING OF WATER AND SEWER SERVICES.
- ALL ELECTRICAL MATERIAL WORKMANSHIP SHALL CONFORM TO THE NATIONAL ELECTRIC CODE, LATEST EDITION, AND ALL APPLICABLE STATE AND LOCAL CODES.
- THE EXACT LOCATION OF NEW UTILITY SERVICES AND CONNECTIONS SHALL BE COORDINATED WITH BUILDING DRAWINGS AND UTILITY COMPANIES.
- ADJUST ALL MANHOLES, CATCH BASINS, CURB BOXES, ETC. WITHIN LIMITS OF WORK TO FINISH GRADE.
- ALL UNDERGROUND CONDUITS SHALL HAVE NYLON PULL ROPES TO FACILITATE PULLING CABLES.
- THE CONTRACTOR SHALL OBTAIN, PAY FOR, AND COMPLY WITH ALL REQUIRED PERMITS, ARRANGE FOR ALL INSPECTIONS, AND SUBMIT COPIES OF ACCEPTANCE CERTIFICATED TO THE OWNER PRIOR TO THE COMPLETION OF PROJECT.
- THE CONTRACTOR SHALL PROVIDE AND INSTALL ALL MANHOLES, BOXES, FITTINGS, CONNECTORS, COVER PLATES AND OTHER MISCELLANEOUS ITEMS NOT NECESSARILY DETAILED IN THESE DRAWING TO RENDER INSTALLATION OF UTILITIES COMPLETE AND OPERATIONAL.
- CONTRACTOR SHALL PROVIDE EXCAVATION, BEDDING, BACKFILL AND COMPACTION FOR NATURAL GAS SERVICES.
- A 10-FOOT MINIMUM EDGE TO EDGE HORIZONTAL SEPARATION SHALL BE PROVIDED BETWEEN ALL WATER AND SANITARY SEWER LINES. AN 18-INCH MINIMUM OUTSIDE TO OUTSIDE VERTICAL SEPARATION SHALL BE PROVIDED AT ALL WATER/SANITARY SEWER CROSSINGS WATER ABOVE SEWER.
- SAWCUT AND REMOVE PAVEMENT AND CONSTRUCT PAVEMENT TRENCH PATCH FOR ALL PROPOSED UTILITIES LOCATED IN EXISTING PAVED AREAS.
- GATE VALVES, FITTINGS, ETC. SHALL MEET THE REQUIREMENTS OF THE CITY OF PORTSMOUTH.
- COORDINATE TESTING OF SEWER CONSTRUCTION WITH THE CITY OF PORTSMOUTH.
- ALL SEWER PIPES WITH LESS THAN 6" COVER SHALL BE INSULATED.
- CONTRACTOR SHALL COORDINATE ALL ELECTRIC WORK INCLUDING BUT NOT LIMITED TO: CONDUIT CONSTRUCTION, MANHOLE CONSTRUCTION, UTILITY POLE CONSTRUCTION, OVERHEAD WIRE RELOCATION, AND TRANSFORMER CONSTRUCTION WITH POWER COMPANY.
- SITE LIGHTING SPECIFICATIONS, CONDUIT LAYOUT AND CIRCUITRY FOR PROPOSED SITE LIGHTING AND SIGN ILLUMINATION SHALL BE PROVIDED BY THE PROJECT ELECTRICAL ENGINEER IN COORDINATION WITH THE SITE CIVIL ENGINEER.
- CONTRACTOR SHALL CONSTRUCT ALL UTILITIES AND DRAINS TO WITHIN 10' OF THE FOUNDATION WALLS AND CONNECT THESE TO SERVICE STUBS FROM THE BUILDING.
- FINAL REVIEW OF ALL UTILITIES SHALL BE MADE DURING THE REQUIRED SEWER CONNECTION PERMIT PROCESS IN COORDINATION WITH DEPARTMENT OF PUBLIC WORKS.
- ALL WORK PERFORMED IN THE PUBLIC RIGHT-OF-WAY SHALL BE BUILT TO DEPARTMENT OF PUBLIC WORKS STANDARDS.
- THE CONTRACTOR SHALL NOTIFY DIG SAFE AT 1-888-DIG-SAFE (1-888-344-7233) AT LEAST 72 HOURS PRIOR TO COMMENCING ANY EXCAVATION ON PUBLIC OR PRIVATE PROPERTY WITHIN 100 FEET OF UNDERGROUND UTILITIES. THE EXCAVATOR IS RESPONSIBLE TO MAINTAIN MARKS. DIG SAFE TICKETS EXPIRE IN THIRTY DAYS.
- UNDERGROUND UTILITY LOCATIONS ARE BASED UPON BEST AVAILABLE EVIDENCE AND ARE NOT FIELD VERIFIED. LOCATING AND PROTECTING ANY ABOVEGROUND OR UNDERGROUND UTILITIES IS THE SOLE RESPONSIBILITY OF THE CONTRACTOR AND/OR THE OWNER. UTILITY CONFLICTS SHOULD BE REPORTED AT ONCE TO THE DESIGN ENGINEER.
- IRRIGATION, IF SUPPLIED, WILL BE PROVIDED ON A SEPARATE METERED SERVICE. DESIGNS OF IRRIGATION WILL BE PROVIDED BY THE LANDSCAPE CONTRACTOR AT THE TIME OF CONSTRUCTION.

ALLOWABLE NON-STORMWATER DISCHARGES

- FIRE-FIGHTING ACTIVITIES;
- FIRE HYDRANT FLUSHING;
- WATERS USED TO WASH VEHICLES WHERE DETERGENTS ARE NOT USED;
- WATER USED TO CONTROL DUST;
- POTABLE WATER INCLUDING UNCONTAMINATED WATER LINE FLUSHING;
- ROUTINE EXTERNAL BUILDING WASH DOWN WHERE DETERGENTS ARE NOT USED;
- PAVEMENT WASH WATERS WHERE DETERGENTS ARE NOT USED;
- UNCONTAMINATED AIR CONDITIONING/COMPRESSOR CONDENSATION;
- UNCONTAMINATED GROUND WATER OR SPRING WATER;
- FOUNDATION OR FOOTING DRAINS WHICH ARE UNCONTAMINATED;
- UNCONTAMINATED EXCAVATION DEWATERING;
- LANDSCAPE IRRIGATION.

WASTE DISPOSAL

- WASTE MATERIAL
 - ALL WASTE MATERIALS SHALL BE COLLECTED AND STORED IN SECURELY LIDDED RECEPTACLES. ALL TRASH AND CONSTRUCTION DEBRIS FROM THE SITE SHALL BE DEPOSITED IN A DUMPSTER;
 - NO CONSTRUCTION WASTE MATERIALS SHALL BE BURIED ON SITE;
 - ALL PERSONNEL SHALL BE INSTRUCTED REGARDING THE CORRECT PROCEDURE FOR WASTE DISPOSAL BY THE SUPERINTENDENT.
- HAZARDOUS WASTE
 - ALL HAZARDOUS WASTE MATERIALS SHALL BE DISPOSED OF IN THE MANNER SPECIFIED BY LOCAL OR STATE REGULATION OR BY THE MANUFACTURER;
 - SITE PERSONNEL SHALL BE INSTRUCTED IN THESE PRACTICES BY THE SUPERINTENDENT.
- SANITARY WASTE
 - ALL SANITARY WASTE SHALL BE COLLECTED FROM THE PORTABLE UNITS A MINIMUM OF ONCE PER WEEK BY A LICENSED SANITARY WASTE MANAGEMENT CONTRACTOR.

BLASTING NOTES

- CONTRACTOR SHALL CONTACT THE NHDES AND/OR LOCAL JURISDICTION PRIOR TO COMMENCING ANY BLASTING ACTIVITIES.
- FOR ANY PROJECT FOR WHICH BLASTING OF BEDROCK IS ANTICIPATED, THE APPLICANT SHALL SUBMIT A BLASTING PLAN THAT IDENTIFIES:
 - WHERE THE BLASTING ACTIVITIES ARE ANTICIPATED TO OCCUR;
 - THE ESTIMATED QUANTITY OF BLAST ROCK IN CUBIC YARDS; AND
 - SITE-SPECIFIC BLASTING BEST MANAGEMENT PRACTICES.

ABBREVIATIONS

@ ANSI APPROX.±	AT AMERICAN NATIONAL STANDARDS INSTITUTE APPROXIMATELY	MAX. MH MIN	MAXIMUM MANHOLE MINIMUM
BLDG	BUILDING	N NE NHDOT N.T.S. NWT	NORTHING NORTHEAST NH DEPT. OF TRANSPORTATION NOT TO SCALE NON WOVEN GEOTEXTILE
CL CB CLR CMP CO CPE	CENTERLINE CATCH BASIN CLEAR CORRUGATED METAL PIPE CLEANOUT CORRUGATED POLYETHYLENE	OD O.C. OH OZ	OUTSIDE DIAMETER ON CENTER OVERHEAD OUNCES
DI DIA	DUCTILE IRON DIAMETER	PERF	PERFORATED
E EL EFM EPS	EASTING ELEVATION EXISTING FORCE MAIN EXTRUDED POLYSTYRENE	PSF PSI PVC PL POH PUGE	POUNDS PER SQUARE FOOT POUNDS PER SQUARE INCH POLYVINYL CHLORIDE PROPERTY LINE PROPOSED OVERHEAD ELECTRIC PROPOSED UNDERGROUND ELECTRIC
FGC FM	FLUSH GRANITE CURB FORCEMAIN	R R&D	RADIUS REMOVE AND DISPOSE
GAL GALV GPH GPM	GALLON GALVANIZED GALLONS PER HOUR GALLONS PER MINUTE	S SCL SCS SDR SE SHT SQ SS SY	SLOPE STORMWATER COLLECTION LINE STORMWATER COLLECTION SYSTEM STANDARD DIMENSION RATIO SOUTHEAST SHEET SQUARE STAINLESS STEEL SQUARE YARD
HDPE HP	HIGH DENSITY POLYETHYLENE HORSEPOWER	TBM TOC TYP	TEMPORARY BENCH MARK TOP OF CONCRETE TYPICAL
ID IN INT. INV.	INSIDE DIAMETER INCHES INTERSECTION INVERT	VGC	VERTICAL GRANITE CURB

LEGEND:

ITEMS SHOWN MAY NOT APPEAR ON PLANS

DESCRIPTION	EXISTING	PROPOSED
PROPERTY LINE	---	---
BENCHMARK	⊕	⊕
SURVEY STATION	⊙	⊙
IRON PIN	⦿	⦿
DRILL HOLE	⦿	⦿
BOUND	⦿	⦿
TEST PIT	⦿	⦿
SEWER MANHOLE	⦿	⦿
GAS VALVE	⦿	⦿
UTILITY POLE	⦿	⦿
GUY ANCHOR	⦿	⦿
ELECTRICAL MANHOLE	⦿	⦿
TRANSFORMER	⦿	⦿
PULL BOX	⦿	⦿
WELL	⦿	⦿
WATER VALVE	⦿	⦿
WATER SHUTOFF	⦿	⦿
HYDRANT	⦿	⦿
AIR RELIEF VALVE	⦿	⦿
DRAINAGE MANHOLE	⦿	⦿
CATCH BASIN	⦿	⦿
CURB INLET	⦿	⦿
PARKING LIGHT	⦿	⦿
FLOOD LIGHT	⦿	⦿
SITE LIGHT	⦿	⦿
SIGN	⦿	⦿
TRASH CAN	⦿	⦿
FLAGPOLE	⦿	⦿
MONITORING WELL	⦿	⦿
EDGE OF GRAVEL	---	---
EDGE OF PAVEMENT	---	---
CURBING	---	---
MAJOR FOOT CONTOUR	---100---	---100---
MINOR FOOT CONTOUR	---98---	---98---
WATERLINE	---W---	---W---
STORM DRAIN	---SD---	---SD---
UNDER DRAIN	---UD---	---UD---
SANITARY SEWER	---SS---	---SS---
FORCE MAIN	---FM---	---FM---
OVERHEAD UTILITIES	---OHU---	---OHU---
UNDERGROUND UTILITIES	---UGU---	---UGU---
GAS LINE	---GAS---	---GAS---
CHAIN LINK FENCE	---X---	---X---
GUARDRAIL	---G---	---G---
SILT FENCE	---SF---	---SF---
TREE LINE	---	---
GRAVEL SURFACE	---	---
PAVED SURFACE	---	---
CONCRETE SURFACE	---	---
BUILDING FOOTPRINT	---	---
WETLANDS	---	---
RIPRAP	---	---

ZONING MAP



Residential Districts	
R	Rural
SRA	Single Residence A
SRB	Single Residence B
GRA	General Residence A
GRB	General Residence B
GRC	General Residence C
GA/MH	Garden Apartment/Mobile Home Park
Mixed Residential Districts	
MRO	Mixed Residential Office
MRB	Mixed Residential Business
G1	Gateway Corridor
G2	Gateway Center

0	2026-06-22	ISSUED FOR TAC REVIEW	SJR	SMT
REV.	DATE	DESCRIPTION	BY	CHK.

ISSUED FOR PERMITTING

HALEY WARD
 200 Griffin Rd., Unit 14
 Portsmouth, New Hampshire 03801
 603.430.9282
 WWW.HALEYWARD.COM

PROPOSED 3 LOT SUBDIVISION
 20 CENTRAL AVENUE, PORTSMOUTH NH

GENERAL NOTES, LEGEND & ABBREVIATIONS

DATE	JUNE 2026	SCALE	NTS
DRAWN BY	SJR	DESIGNED BY	NMT
CHECKED BY	DJO	PROJECT No.	5010658.001
DRAWING No.	C001	REV.	0

STATE OF NEW HAMPSHIRE
 DREW JOHN OLEHOWSKI
 No. 18516
 PROFESSIONAL ENGINEER
 06/22/2026

LEGEND:

DESCRIPTION	EXISTING
RCRD 6478/413	ROCKINGHAM COUNTY REGISTRY OF DEEDS DEED BOOKPAGE
N/F	NOW OR FORMALLY
TYP.	TYPICAL
INV.	INVERT
ELV.	ELEVATION
FF	FINISHED FLOOR
LSA	LANDSCAPE AREA
SGC	SLOPED GRANITE CURB
MAP 21 LOT 8	
BENCHMARK	
IRON ROD/PIPE FOUND	
SEWER MANHOLE	
DRAIN MANHOLE	
UTILITY POLE	
CATCH BASIN	
HYDRANT	
GATE VALVE	
TREES	
GAS/ELECTRIC METER	
SIGN	
PROPERTY LINE	
APPROXIMATE EXTERIOR PROPERTY LINE	
EDGE OF PAVEMENT	
MINOR FOOT CONTOUR	
MAJOR FOOT CONTOUR	
WATER LINE	
STORM DRAIN LINE	
SANITARY SEWER LINE	
OVERHEAD UTILITY LINE	

- PLAN REFERENCES:**
- 1) PLAN OF LAND PORTSMOUTH, N.H. FOR RAYMOND E. & IDELLE E. ST. LAURENT, PREPARED BY JOHN W. DURGIN CIVIL ENGINEERS, DATED: AUG. 1970, SCALE: 1 IN = 20 FT., DURGIN FILE NO. 501 PLAN NO. 4160, NOT RECORDED.
 - 2) PLAN OF LAND PORTSMOUTH, N.H. FOR JOSEPH LAMB, PREPARED BY JOHN W. DURGIN CIVIL ENGINEERS, DATED: DEC. 1968, SCALE: 1 IN = 20 FT., DURGIN FILE NO. 501 PLAN NO. 465, RCRD C-1303.
 - 3) PLAN OF LAND PORTSMOUTH, N.H., CAVARETTA TO COTTELL, PREPARED BY JOHN W. DURGIN CIVIL ENGINEERS, DATED: AUG 1975, SCALE: 1 IN = 20 FT., DURGIN FILE NO. 501 PLAN NO. 4384, RCRD C-5407.
 - 4) PROPOSED LOT LINE ADJUSTMENT BETWEEN FRANCIS X. & MICHELLE QUINN & KEITH R. & LINDA MAHLER, CUTTS ST., PORTSMOUTH, NH, PREPARED BY: BARRETT ASSOCIATES, DATED: SEPT. 25, 1995, SCALE: 1"=10', RCRD C-24422.
 - 5) PLAN OF THE SUBDIVISION OF A PART OF THE JACKSON FARM, PORTSMOUTH, NH, DATED: MARCH 1902, SCALE: 40 FEET TO AN INCH, RCRD 00226.
 - 6) BOARD OF ASSESSORS LOT PLAN NO. 82, PORTSMOUTH, N.H., RCRD 01101.
 - 7) PLAN OF PROPOSED FEDERAL AID PROJECT I-95(119)15 CONTRACT NO. 1, N.H. PROJECT NO. P-3875-E, INTERSTATE ROUTE 95, DATED: 8-5-70, SCALE: 1" = 50', FILE NO. P.O.4992, ON FILE AT N.H. D.O.T.

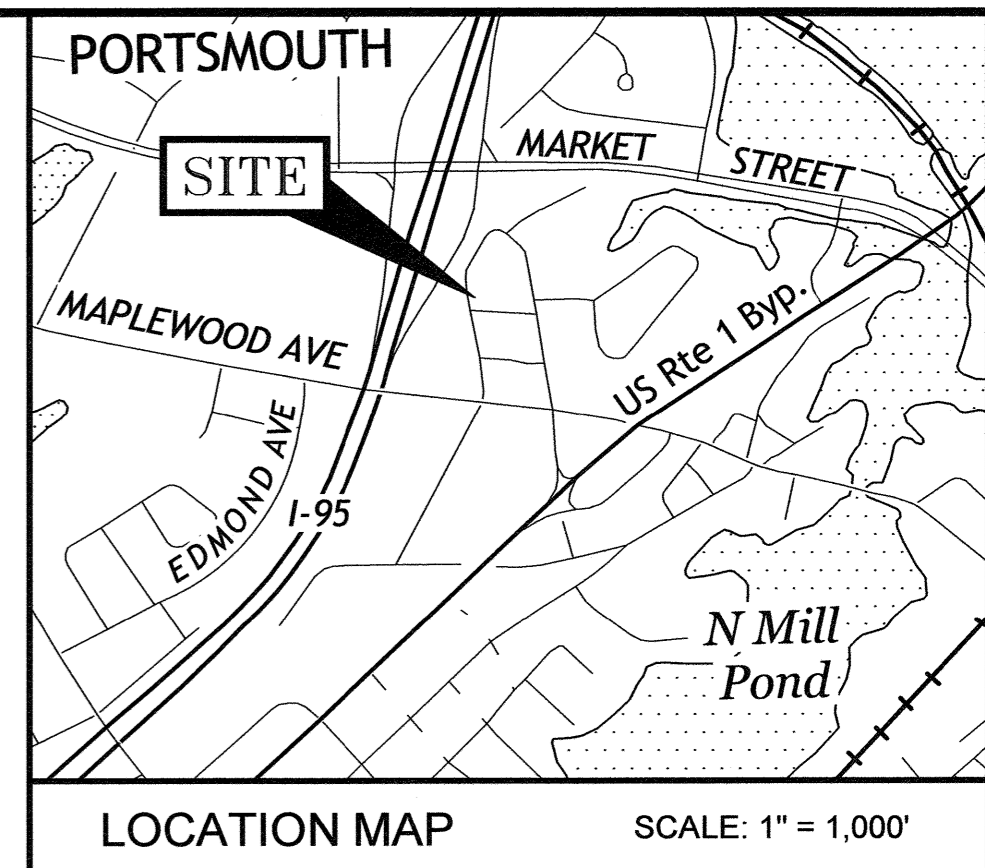

- NOTES:**
- 1) PARCEL IS SHOWN ON THE CITY OF PORTSMOUTH ASSESSOR'S MAP 209 AS LOT 30.
 - 2) OWNER OF RECORD: MARISSA VALVERDE, 20 CENTRAL AVENUE, PORTSMOUTH, NH 03801, 6478/1413.
 - 3) PARCEL IS NOT IN A SPECIAL FLOOD HAZARD AREA ZONE AS SHOWN ON FIRM PANEL 330150259F, EFFECTIVE JANUARY 29, 2021.
 - 4) EXISTING LOT AREA: 28,981 S.F., 0.6653 ACRES.
 - 5) PARCEL IS LOCATED IN THE GENERAL RESIDENCE A (GRA) ZONING DISTRICT.
 - 6) DIMENSIONAL REQUIREMENTS:

MINIMUM LOT AREA:	7,500 S.F.
MINIMUM STREET FRONTAGE:	100 FEET
MINIMUM LOT DEPTH:	70 FEET
SETBACKS:	
FRONT:	15 FEET
SIDE:	10 FEET
REAR:	20 FEET
MAXIMUM BUILDING COVERAGE:	25%
MAXIMUM STRUCTURE HEIGHT:	
SLOPED ROOF:	35 FEET
FLAT ROOF:	30 FEET
ROOF APPURTENANCE HEIGHT:	8 FEET
MINIMUM OPEN SPACE:	30%
 - 7) THE PURPOSE OF THIS PLAN IS TO SHOW THE RESULTS OF AN EXISTING CONDITIONS SURVEY OF ASSESSOR'S MAP 209, LOT 30 IN THE CITY OF PORTSMOUTH.
 - 8) VERTICAL DATUM IS NAVD88. BASIS OF VERTICAL DATUM IS REDUNDANT RTN GNSS OBSERVATIONS.
 - 9) ADJUTER INFORMATION TAKEN FROM THE CITY OF PORTSMOUTH ASSESSOR'S GIS WEBSITE.
 - 10) THIS IS AN ABOVE THE GROUND SURVEY. THE UNDERGROUND UTILITIES, IF SHOWN, ARE BASED UPON BEST AVAILABLE EVIDENCE AND SURFACE FEATURES VISIBLE AT THE TIME OF THE SURVEY. THESE LOCATIONS SHOULD BE CONSIDERED APPROXIMATE. THERE MAY BE ADDITIONAL UNDERGROUND UTILITIES NOT SHOWN ON THIS PLAN. IT IS RECOMMENDED THAT FIELD VERIFICATION OF THE TRUE LOCATION OF ANY UNDERGROUND UTILITIES IS PERFORMED PRIOR TO ANY EXCAVATION.
 - 11) THIS PLAN IS THE RESULT OF AN ON-THE-GROUND INSTRUMENT SURVEY PERFORMED BY HALEY WARD, INC., 4/15/2026.
 - 12) PARCEL IS SUBJECT TO A 10-FOOT WIDE SEWER EASEMENT AND A 10-FOOT WIDE DRAINAGE EASEMENT AS SHOWN ON PLANS OF PROPOSED FEDERAL AID R.O.W. PROJECT I-95(110)14 RECORDED IN ROCKINGHAM COUNTY REGISTRY OF DEEDS, PLAN NO. D-2498, SHEET 6. SEE ALSO, FOURTH EMENTATION TO COMMISSIONERS' RETURN OF HIGHWAY LAYOUT, PORTSMOUTH I-95(10)14-P-5875-B, DATED MARCH 27, 1989, RECORDED IN ROCKINGHAM COUNTY REGISTRY OF DEEDS, BOOK 1957, PAGE 162 SEE ALSO RCRD PLAN #01101 AND BOOK 991, PAGE 351.
 - 13) THE DRAIN LINE SHOWN HEREON WITHIN THE 10' WIDE SEWER EASEMENT APPEARS TO HAVE BEEN SEPARATED AND CONVERTED TO A DRAINAGE LINE.

SEWER STRUCTURE TABLE

STRUCTURE	PROP/EX	RIM	PIPE SIZE/TYPE	INVERT IN	INVERT OUT	DIRECTION
SMH 1	EX	25.13	6" PVC	17.43	17.43	NE
			8" PVC			SE
SMH 2	EX	20.26	8" PVC	10.76	10.76	NW
			8" PVC			NW
			8" PVC			SE
			8" PVC			E
SMH 3	EX	15.52	8" PVC	10.12	10.12	NW
			8" PVC			SE
SMH 4	EX	24.18	8" PVC	9.18	10.02	SE
			8" PVC			W
			8" PVC			S
			6" PVC			SE
			8" PVC			NW

DRAINAGE STRUCTURE TABLE

STRUCTURE	PROP/EX	RIM	PIPE SIZE/TYPE	INVERT IN	INVERT OUT	DIRECTION
CB 1	EX	23.81	8" CPP	20.31	19.26	NW
			12" CPP			SW
DMH 1	EX	23.81	12" CPP	19.01	19.01	NE
			12" CPP			SE
CB 2	EX	18.81	15" RCP	16.11	16.06	NW
			12" CPP			SE
DMH 2	EX	20.43	12" CPP	13.58	13.03	NW
			15" RCP			SE
			12" CPP			SE
			24" CPP			E
DMH 3	EX	20.70	8" PVC	15.80	15.80	SE
			6" CLAY			SE
CB 3	EX	20.09	8" PVC	16.69	16.69	NE
DMH 4	EX	20.17	BRICK TROUGH	7.77	7.77	SW
			BRICK TROUGH			NE
DMH 5	EX	20.43	12" CPP	14.93	13.03	NW
			12" CPP			SE
			12" CPP			SE
			12" CPP			S
DMH 6	EX	20.36	12" CPP	15.61	15.61	SE
			12" CPP			E
CB 4	EX	20.17	12" CPP	16.37	16.37	E
CB 5	EX	19.32	12" CPP	14.62	14.62	NW
CB 6	EX	15.15	12" CPP	11.15	11.15	E
CB 7	EX	15.28	8" CPP	11.88	11.88	W
			12" CPP			E
DMH 7	EX	15.85	12" CPP	11.05	11.58	W
			4" PVC			NE
			12" CPP			NE
DMH 8	EX	16.73	12" CPP	11.33	10.85	W
			12" CPP			SW
			12" CPP			E
			4" PVC			NE
CB 8	EX	17.71	24" RCP	10.23	10.23	N
CB 9	EX	17.24	12" CPP	12.74	12.74	SE
			12" CPP			W
CB 10	EX	13.37	BRICK TROUGH	3.17	3.17	SE
			BRICK TROUGH			NW
DMH 9	EX	16.48	24" RCP	8.28	8.28	SW
			24" RCP			S
			36" RCP			NE

"I CERTIFY THAT THIS PLAN WAS PREPARED UNDER MY DIRECT SUPERVISION, THAT IT IS THE RESULT OF A FIELD SURVEY BY THIS OFFICE AND HAS AN ACCURACY OF THE CLOSED TRAVERSE THAT EXCEEDS THE PRECISION OF 1:15,000."

Charles S. Adams

CHARLES S. ADAMS, LLS 1622

DATE: 04-29-2026

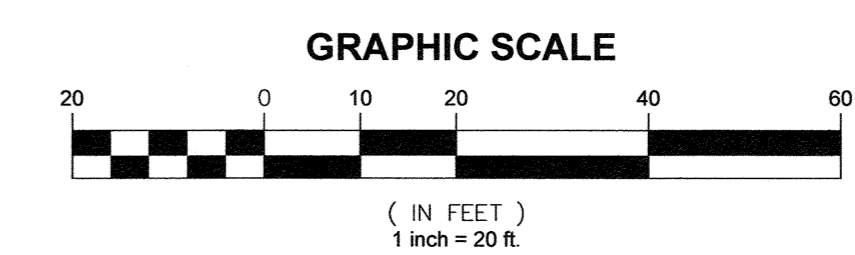
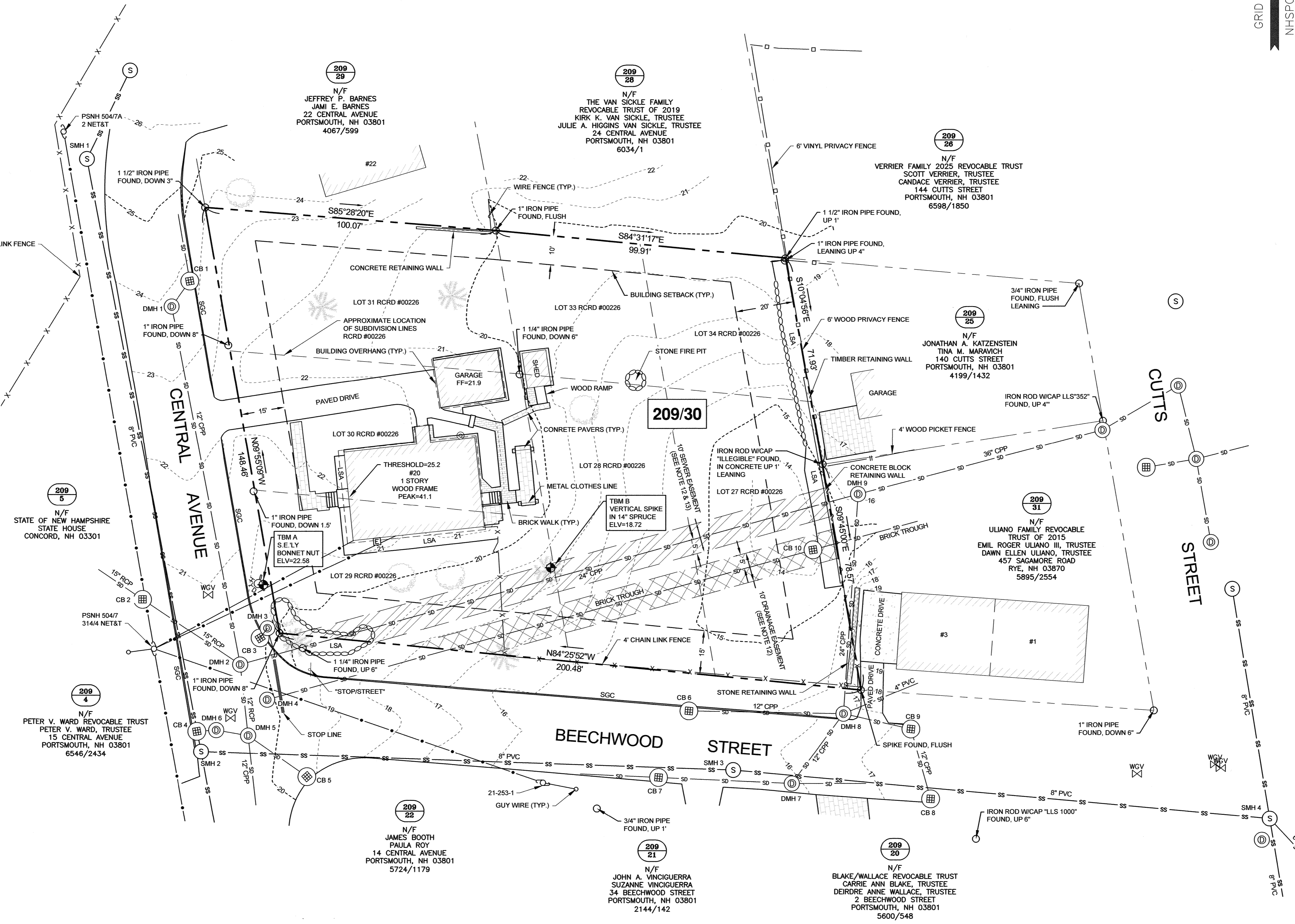

REV.	DATE	ISSUED FOR COMMENT	DESCRIPTION	RJB	CSA
0	4/21/26				

DRAWING ISSUE STATUS

SITE SURVEY

HALEY WARD
ENGINEERING | ENVIRONMENTAL | SURVEYING

200 Griffin Road, Unit 14
Portsmouth, NH 03801
603-430-9282

PROJECT: **COPLEY PROPERTIES**
20 CENTRAL AVENUE, PORTSMOUTH, NH

TITLE: **EXISTING CONDITIONS PLAN**

DATE	SCALE
APRIL 2026	1"=20'
DRAWN BY: RJB	DESIGNED BY: ---
CHECKED BY: CSA	
PROJECT No. 5010658.001	FIELD BOOK / PAGE FB 433 PG 37
DRAWING No. V101	REV. 0

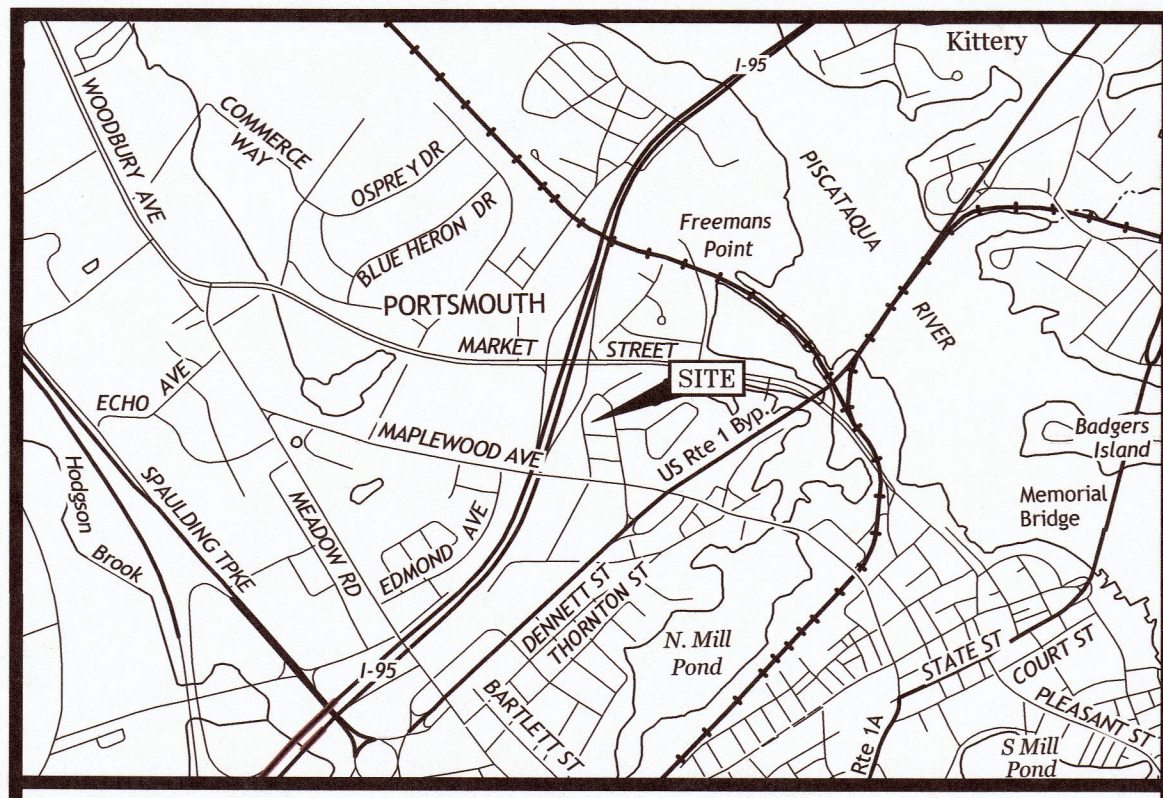

LOCATION MAP SCALE: 1"=2000'

LEGEND:

DESCRIPTION	EXISTING
RCRD 1234/123	ROCKINGHAM COUNTY REGISTRY OF DEEDS DEED BOOK/PAGE NOW OR FORMALLY
N/F	TYPICAL
TYP	TO BE REMOVED
TBR	TO BE SET
TBS	SINGLE WHITE LINE
SWL	DOUBLE YELLOW LINE
DYL	SLOPED GRANITE CURB
SGC	
MAP 21 LOT 8	
IRON ROD/PIPE FOUND	
UTILITY POLE	
ELECTRIC METER	
PROPERTY LINE	
APPROXIMATE EXTERIOR PROPERTY LINE	
EDGE OF PAVEMENT	
OVERHEAD UTILITY LINE	

PLAN REFERENCES:

- 1) PLAN OF LAND PORTSMOUTH, N.H. FOR RAYMOND E. & IDELLE E. ST. LAURENT, PREPARED BY JOHN W. DURGIN CIVIL ENGINEERS, DATED: AUG. 1970, SCALE: 1 IN = 20 FT., DURGIN FILE NO. 501 PLAN NO. 4160, NOT RECORDED.
- 2) PLAN OF LAND PORTSMOUTH, N.H. FOR JOSEPH LAMB, PREPARED BY JOHN W. DURGIN CIVIL ENGINEERS, DATED: DEC. 1968, SCALE: 1 IN = 20 FT., DURGIN FILE NO. 501 PLAN NO. 465, RCRD C-1303.
- 3) PLAN OF LAND PORTSMOUTH, N.H., CAVARETTA TO COTTRELL, PREPARED BY JOHN W. DURGIN CIVIL ENGINEERS, DATED: AUG 1975, SCALE: 1 IN = 20 FT., DURGIN FILE NO. 501 PLAN NO. 4384, RCRD C-5407.
- 4) PROPOSED LOT LINE ADJUSTMENT BETWEEN FRANCIS X. & MICHELLE QUINN & KEITH R. & LINDA MAHLER, CUTTS ST. PORTSMOUTH, NH, PREPARED BY BARRETT ASSOCIATES, DATED: SEPT. 25, 1995, SCALE: 1"=10', RCRD C-24422.
- 5) PLAN OF THE SUBDIVISION OF A PART OF THE JACKSON FARM, PORTSMOUTH, NH, DATED: MARCH 1902, SCALE: 40 FEET TO AN INCH, RCRD 00226.
- 6) BOARD OF ASSESSORS LOT PLAN NO. 32, PORTSMOUTH, N.H., RCRD 01101.
- 7) PLAN OF PROPOSED FEDERAL AID PROJECT I-95-1(1915) CONTRACT NO. 1, N.H. PROJECT NO. P-3875-E, INTERSTATE ROUTE 95, DATED: 8-5-70, SCALE: 1"=50', FILE NO. P.O.4992, ON FILE AT N.H. D.O.T.

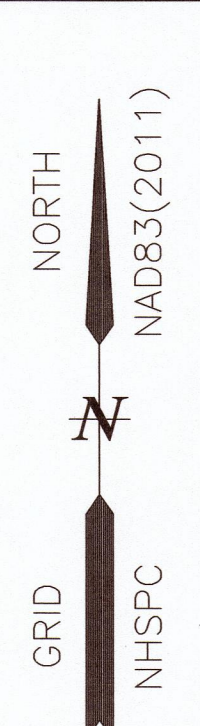
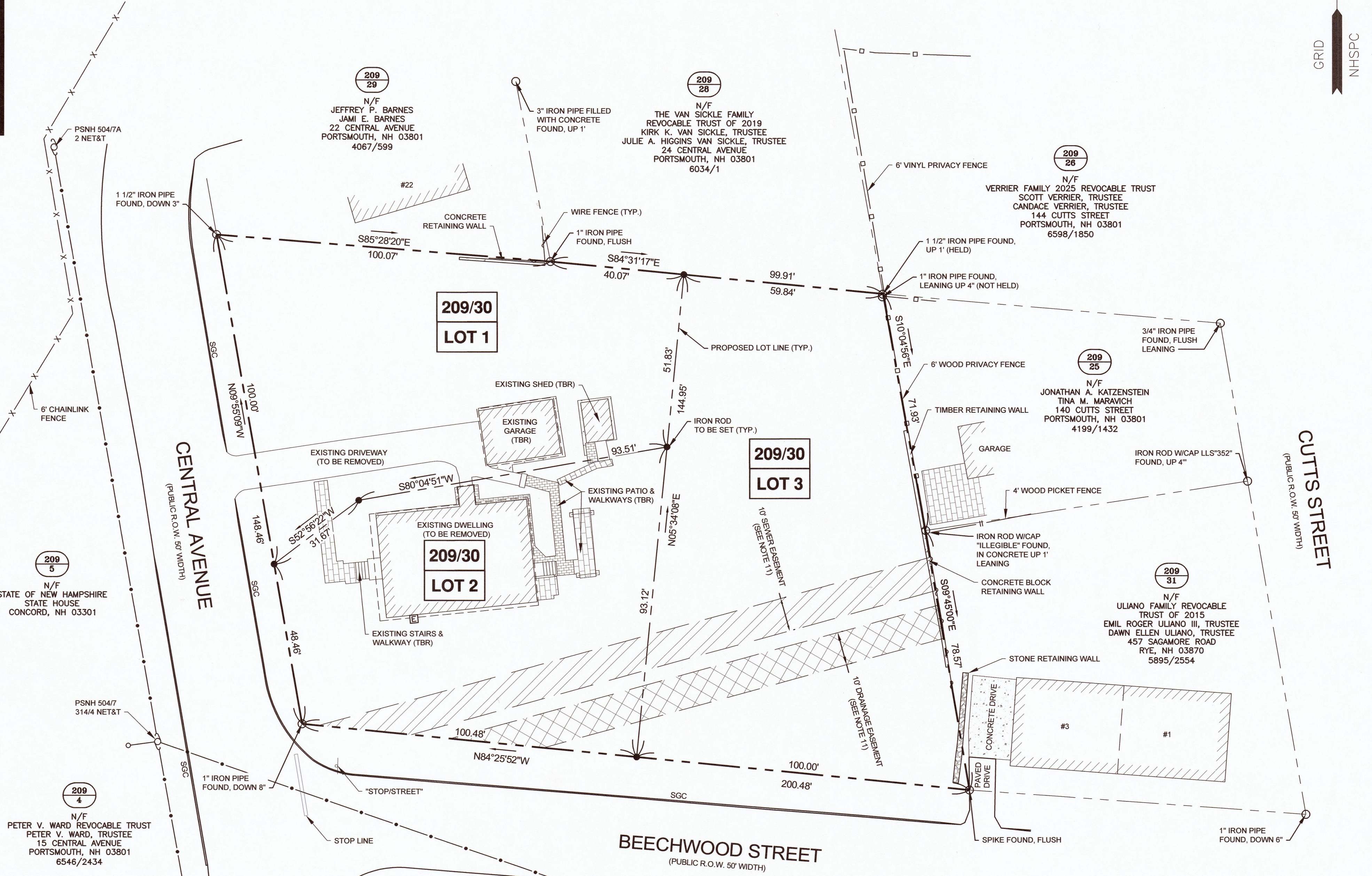

- NOTES:**
- 1) PARCEL IS SHOWN ON THE CITY OF PORTSMOUTH ASSESSOR'S MAP 209 AS LOT 30.
 - 2) OWNER OF RECORD: MARISSA VALVERDE, 20 CENTRAL AVENUE, PORTSMOUTH, NH 03801, 6478/1413.
 - 3) PARCEL IS NOT IN A SPECIAL FLOOD HAZARD AREA ZONE AS SHOWN ON FIRM PANEL 33015C0259F, EFFECTIVE JANUARY 29, 2021.
 - 4) EXISTING LOT AREA: 28,981 S.F. (0.6653 ACRES).
 - 5) PARCEL IS LOCATED IN THE GENERAL RESIDENCE A (GRA) ZONING DISTRICT.
 - 6) DIMENSIONAL REQUIREMENTS:

MINIMUM LOT AREA:	7,500 S.F.
MINIMUM STREET FRONTAGE:	100 FEET
MINIMUM LOT DEPTH:	70 FEET
SETBACKS:	FRONT: 15 FEET
	SIDE: 10 FEET
	REAR: 20 FEET
MAXIMUM BUILDING COVERAGE:	25%
MAXIMUM STRUCTURE HEIGHT:	SLOPED ROOF: 35 FEET
	FLAT ROOF: 30 FEET
ROOF APPURTENANCE HEIGHT:	8 FEET
MINIMUM OPEN SPACE:	30%
 - 7) THE PURPOSE OF THIS PLAN IS TO SHOW A PROPOSED 3 LOT SUBDIVISION OF ASSESSOR'S MAP 209, LOT 30 IN THE CITY OF PORTSMOUTH.
 - 8) ABUTTER INFORMATION TAKEN FROM THE CITY OF PORTSMOUTH ASSESSOR'S GIS WEBSITE.
 - 9) THIS IS AN ABOVE THE GROUND SURVEY. THE UNDERGROUND UTILITIES, IF SHOWN, ARE BASED UPON BEST AVAILABLE EVIDENCE AND SURFACE FEATURES VISIBLE AT THE TIME OF THE SURVEY. THESE LOCATIONS SHOULD BE CONSIDERED APPROXIMATE. THERE MAY BE ADDITIONAL UNDERGROUND UTILITIES NOT SHOWN ON THIS PLAN. IT IS RECOMMENDED THAT FIELD VERIFICATION OF THE TRUE LOCATION OF ANY UNDERGROUND UTILITIES IS PERFORMED PRIOR TO ANY EXCAVATION.
 - 10) THIS PLAN IS THE RESULT OF AN ON-THE-GROUND INSTRUMENT SURVEY PERFORMED BY HALEY WARD, INC. 4/15/2026.
 - 11) PARCEL IS SUBJECT TO A 10-FOOT WIDE SEWER EASEMENT AND A 10-FOOT WIDE DRAINAGE EASEMENT AS SHOWN ON PLANS OF PROPOSED FEDERAL AID R.O.W. PROJECT I-95-1(01)14 RECORDED IN ROCKINGHAM COUNTY REGISTRY OF DEEDS, PLAN NO. D-2488, SHEET 6. SEE ALSO, FOURTH EMENDATION TO COMMISSIONERS' RETURN OF HIGHWAY LAYOUT, PORTSMOUTH I-95(10)14-P-5875-B, DATED MARCH 27, 1969, RECORDED IN ROCKINGHAM COUNTY REGISTRY OF DEEDS, BOOK 1957, PAGE 162 SEE ALSO RCRD PLAN #01101 AND AND BOOK 991, PAGE 351.

"I CERTIFY THAT THIS PLAN WAS PREPARED UNDER MY DIRECT SUPERVISION, THAT IT IS THE RESULT OF A FIELD SURVEY BY THIS OFFICE AND HAS AN ACCURACY OF THE CLOSED TRAVERSE THAT EXCEEDS THE PRECISION OF 1:15,000."

CHARLES S. ADAMS, LLS 1622
DATE: 06-19-2026

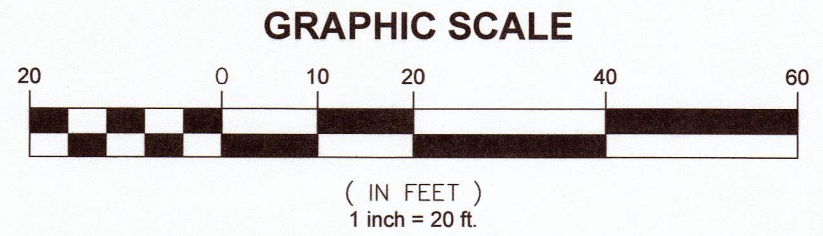
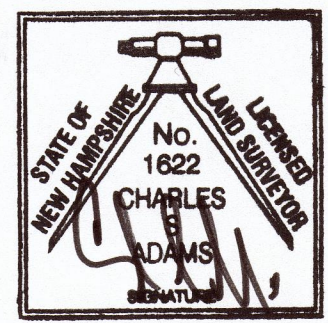

REV.	DATE	DESCRIPTION	BY	CHK.
0	5/15/26	ISSUED FOR COMMENT	CSA	RJB

DRAWING ISSUE STATUS: **SITE SURVEY**

SUBDIVISION PLAN
TAX MAP 209 - LOT 30
OWNER
MARISSA VALVERDE
20 CENTRAL AVENUE
CITY OF PORTSMOUTH
COUNTY OF ROCKINGHAM
STATE OF NEW HAMPSHIRE

TABLE OF DIMENSIONAL STANDARDS:

REGULATION	REQUIRED	LOT 1	LOT 2	LOT 3
MIN. LOT AREA	7,500 S.F.	9,074 S.F.	8,302 S.F.	11,605 S.F.
STREET FRONTAGE	100 FEET	100 FEET	148 FEET	100 FEET
MIN. FRONT SETBACK	15 FEET	27.5 FEET	19.3 FEET	51.6 FEET
MIN. SIDE SETBACK	10 FEET	10.4 FEET	11.8 FEET	10.6 FEET
MIN. REAR SETBACK	20 FEET	58.9 FEET	20.7 FEET	45.7 FEET
MAX. HEIGHT SLOPED ROOF	35 FEET	< 35 FEET	< 35 FEET	< 35 FEET
MAX. BUILDING COVERAGE	25%	19.8%	23.5%	15.5%
MIN. OPEN SPACE	30%	71.1%	63.6%	75.0%

**TOTAL IMPERVIOUS SURFACE AREAS:
(TO PROPERTY LINES)**

LOT 1	LOT 2	LOT 3	TOTAL
2,620 S.F.	3,018 S.F.	2,901 S.F.	8,539 S.F.

UTILITY NOTES:

- REFER TO DWG C001 FOR GENERAL NOTES, LEGEND, & ABBREVIATIONS.
- REFER TO DWGS C501 FOR ALL CONSTRUCTION DETAILS.
- ALL PROPOSED SEWER LINES TO BE 6" PVC SDR 35 GASKETED.
- THE SPACING BETWEEN ELECTRICAL AND COMMUNICATION LINES ON THIS PLAN IS EXAGGERATED FOR CLARITY AND INTENDED TO SHOW THE GENERAL LOCATION OF PROPOSED UTILITIES. THE FINAL LOCATIONS AND SPACING MAY BE ADJUSTED TO RUN WITHIN THE SAME TRENCH PER THE CONSTRUCTION DETAILS.
- FIRE SUPPRESSION IS NOT PROPOSED FOR THIS DEVELOPMENT.
- THE CONTRACT SHALL ENSURE ALL SEWER SERVICES HAVE A MINIMUM OF 6" OF COVER. IF THE MINIMUM COVER CANNOT BE OBTAINED, INSULATION SHALL BE INSTALLED.
- ALL PROPOSED WATER LINES SHALL BE 1"

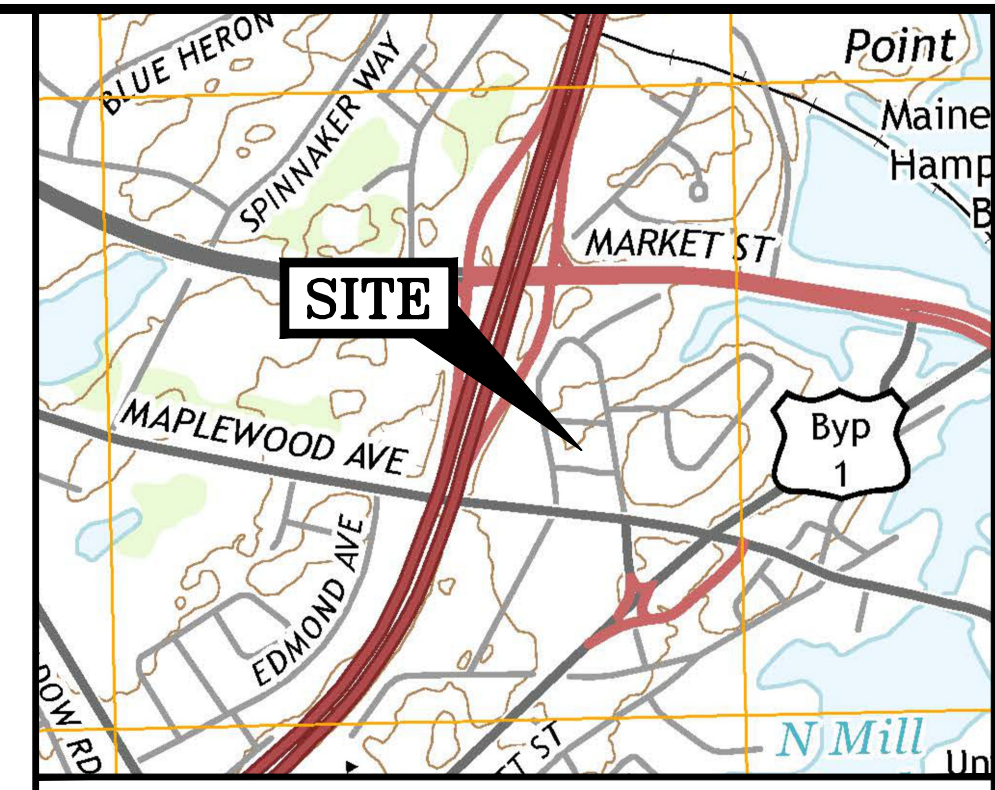

LOCATION MAP SCALE: 1" = 1,000'

NOTES:

- PARCEL IS SHOWN ON THE CITY OF PORTSMOUTH ASSESSOR'S MAP 209 AS LOT 30.
- OWNER OF RECORD (MAP 209 LOT 30):
MARISSA VALVERDE
20 CENTRAL AVENUE
PORTSMOUTH, NH 03801
6478/1413
- APPLICANT:
CORLEY PROPERTIES, LLC
94 PORTSMOUTH AVENUE
STRATHAM, NH 03885
- PARCEL IS NOT IN A SPECIAL FLOOD HAZARD AREA ZONE AS SHOWN ON FIRM PANEL 33015C0259F, EFFECTIVE JANUARY 29, 2021.
- PARCEL IS LOCATED IN THE GENERAL RESIDENCE A (GRA) ZONING DISTRICT.
- EXISTING LOT AREA:
28,981 S.F.
0.6653 ACRES
- REFER TO THE EXISTING CONDITIONS PLAN (DWG. NO. V101) FOR ADDITIONAL SITE INFORMATION.
- THE PURPOSE OF THIS PLAN IS PROPOSE A 3 LOT SUBDIVISION ON ASSESSOR'S MAP 209, LOT 30, IN THE CITY OF PORTSMOUTH.
- ALL EXISTING SITE FEATURES, STRUCTURES, AND BUILDINGS ON THE SUBJECT PARCEL ARE TO BE DEMOLISHED AND REMOVED AS PART OF THIS DEVELOPMENT. SEE DEMOLITION PLAN.
- TRASH DISPOSAL SHALL BE PORTSMOUTH CURBSIDE PICKUP.
- LIGHTING SHALL BE STANDARD RESIDENTIAL WALL MOUNTED ONLY AND DARK SKY COMPLIANT.

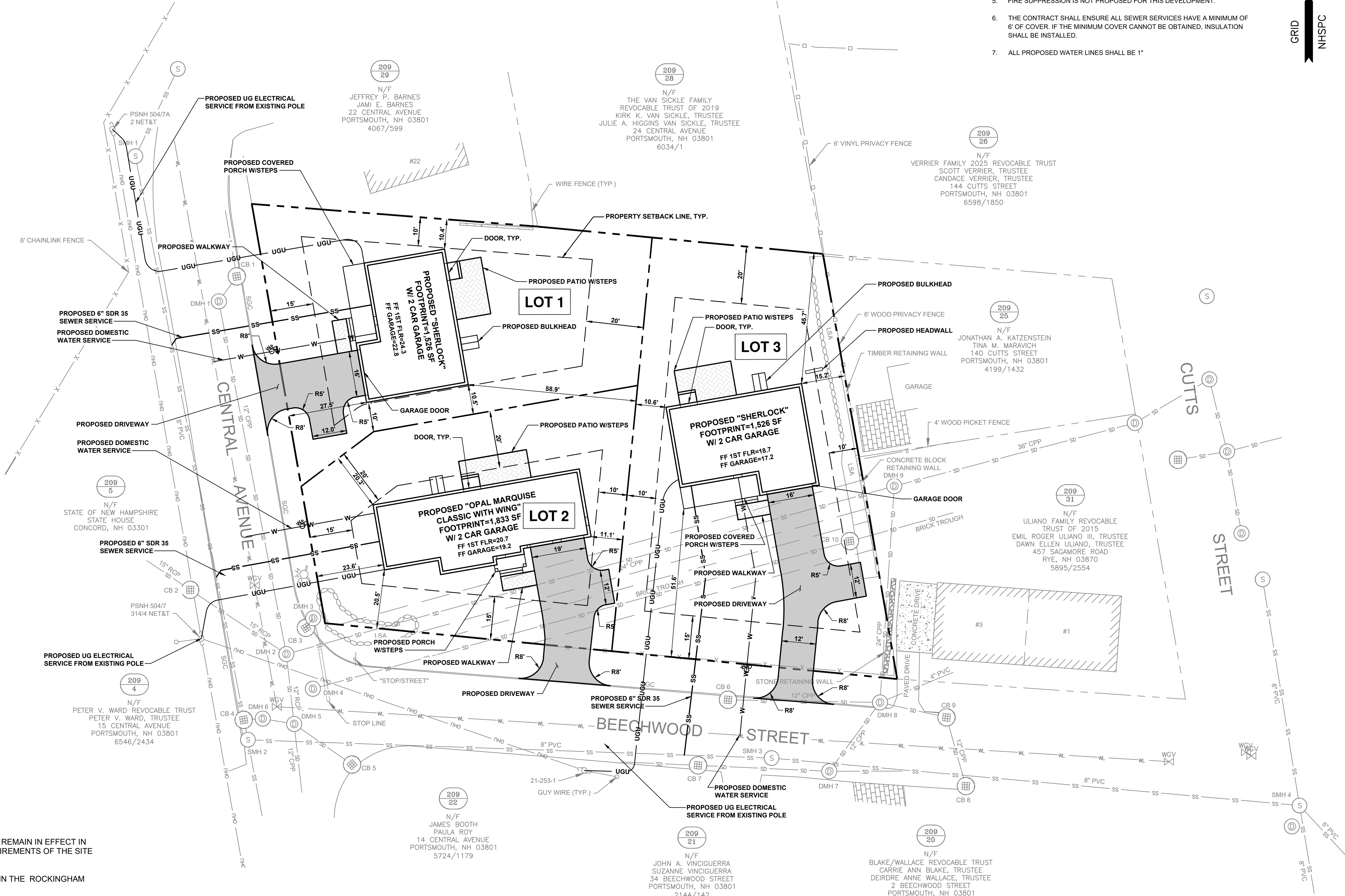

CONDITIONS OF APPROVAL:

- ALL CONDITIONS ON THIS PLAN SHALL REMAIN IN EFFECT IN PERPETUITY PURSUANT TO THE REQUIREMENTS OF THE SITE PLAN REVIEW REGULATIONS.
- THIS SITE PLAN SHALL BE RECORDED IN THE ROCKINGHAM COUNTY REGISTRY OF DEEDS.
- ALL IMPROVEMENTS SHOWN ON THIS SITE PLAN SHALL BE CONSTRUCTED AND MAINTAINED IN ACCORDANCE WITH THE PLAN BY THE PROPERTY OWNER AND ALL FUTURE PROPERTY OWNERS. NO CHANGES SHALL BE MADE TO THIS SITE PLAN WITHOUT THE EXPRESS APPROVAL OF THE PORTSMOUTH PLANNING DIRECTOR.

APPROVED BY THE PORTSMOUTH PLANNING BOARD

CHAIRMAN _____ DATE _____

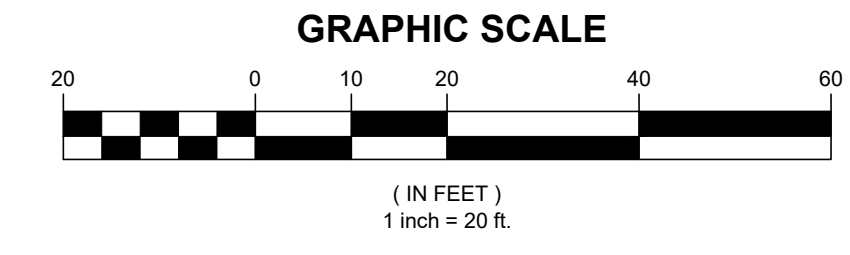

REV.	DATE	DESCRIPTION	BY	CHK.
0	2026.06.22	ISSUED FOR TAC REVIEW	SJR	SMT

ISSUED FOR PERMITTING

HALEY WARD
200 Griffin Rd., Unit 14
Portsmouth, New Hampshire 03801
603.430.9282

PROPOSED 3 LOT SUBDIVISION
20 CENTRAL AVENUE, PORTSMOUTH, NH 03801

SITE LAYOUT & UTILITY PLAN

DATE	SCALE
APRIL 2026	1"=20'
DRAWN BY: SJR	DESIGNED BY: NMT
PROJECT No: 5010658.001	CHECKED BY: DJO
DRAWING No: C102	REV: 0



FILE LOCATION: P:\N1610668\CORLEY_PROPERTIES\5010658\CAD_FILES\C102\DWG_C102.DWG, 2026.06.22, 11:21 AM

NOTES:

1. THE CONTRACTOR SHALL NOTIFY DIG SAFE AT 1-888-DIG-SAFE (1-888-344-7233) AT LEAST 72 HOURS PRIOR TO COMMENCING ANY EXCAVATION ON PUBLIC OR PRIVATE PROPERTY WITHIN 100 FEET OF UNDERGROUND UTILITIES. THE EXCAVATOR IS RESPONSIBLE TO MAINTAIN MARKS. DIG SAFE TICKETS EXPIRE IN THIRTY DAYS.
2. UNDERGROUND UTILITY LOCATIONS ARE BASED UPON BEST AVAILABLE EVIDENCE AND ARE NOT FIELD VERIFIED. LOCATING AND PROTECTING ANY ABOVEGROUND OR UNDERGROUND UTILITIES IS THE SOLE RESPONSIBILITY OF THE CONTRACTOR AND/OR THE OWNER. UTILITY CONFLICTS SHOULD BE REPORTED AT ONCE TO THE DESIGN ENGINEER.
3. CONTRACTOR SHALL INSTALL AND MAINTAIN EROSION CONTROL MEASURES IN ACCORDANCE WITH THE 'NEW HAMPSHIRE STORMWATER MANUAL, VOLUME 3, EROSION AND SEDIMENT CONTROLS DURING CONSTRUCTION, (NHDES DECEMBER 2008).

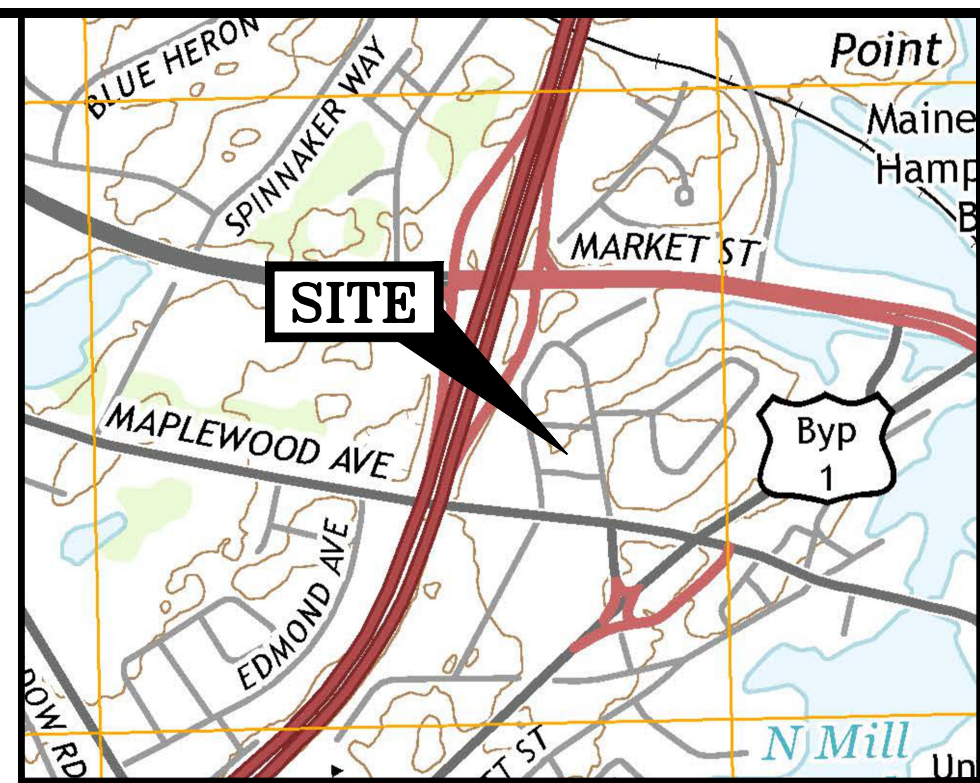

LOCATION MAP SCALE: 1" = 1,000'

DRAINAGE NOTES:

1. REFER TO DWG C001 FOR GENERAL NOTES, LEGEND, AND ABBREVIATIONS.
2. REFER TO DWGS C501-502 FOR ALL CONSTRUCTION DETAILS.
3. ROOF RUNOFF SHALL BE COLLECTED WITH DRIP STRIPS OR A GUTTER COLLECTION SYSTEM AND CONNECTED TO THE STORMWATER SYSTEM.
4. ALL FOOTING DRAINS SHALL BE CONNECTED TO THE STORMWATER SYSTEM WITH A PROVIDED AIR GAP.
5. VERTICAL DATUM IS NAVD88. BASIS OF VERTICAL DATUM IS REDUNDANT RTN GNSS OBSERVATIONS.
6. PORTSMOUTH STORMWATER CONNECTION PERMIT REQUIRED.

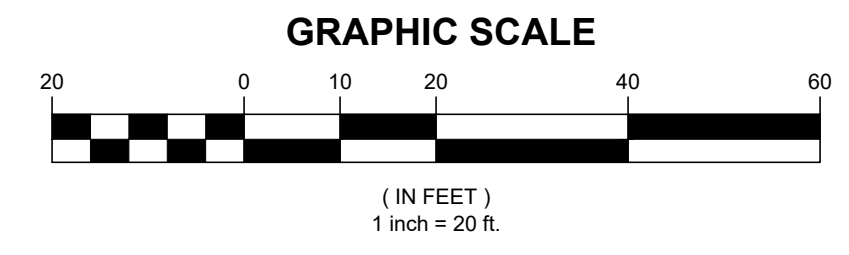
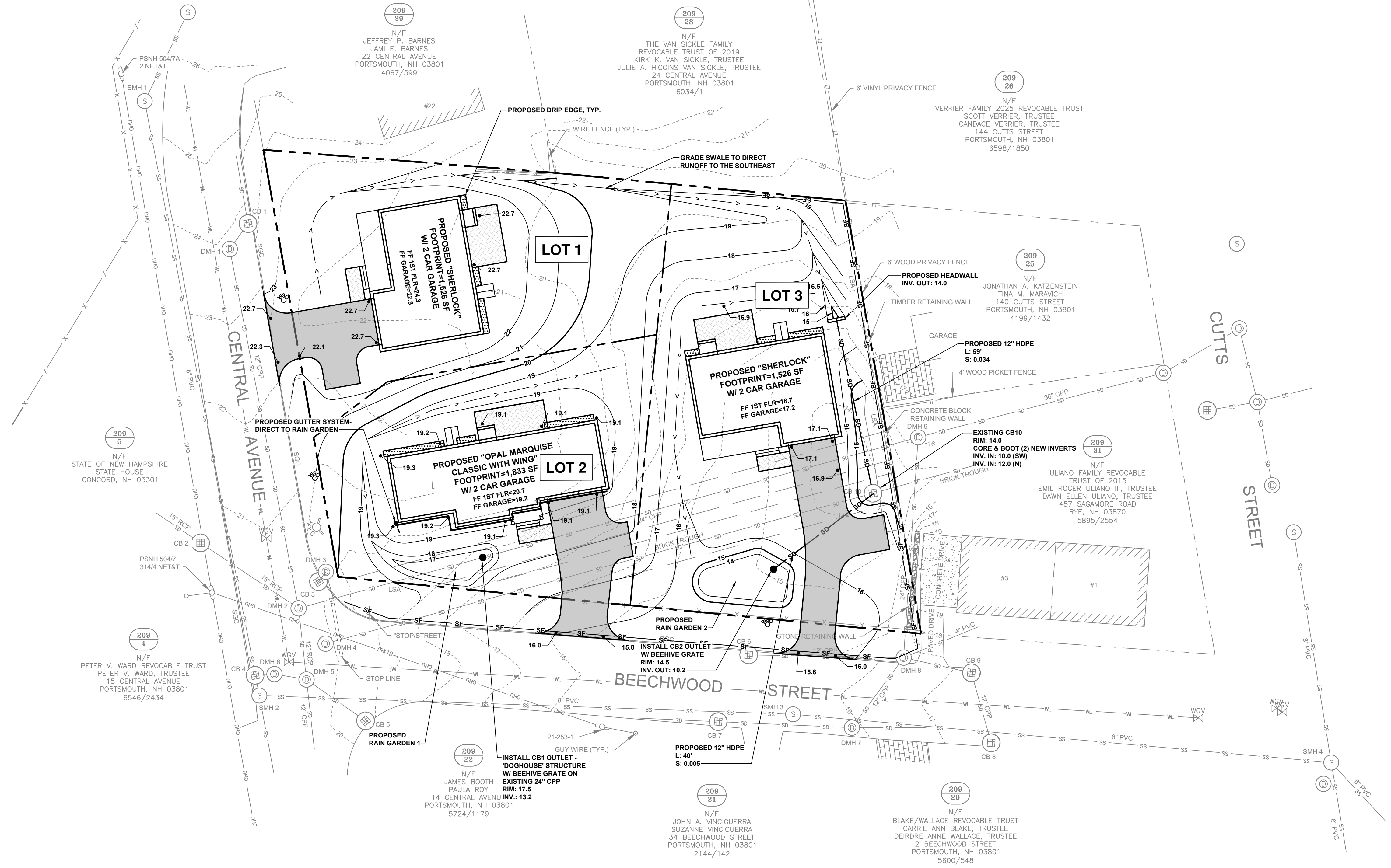

0	2026-06-22	ISSUED FOR TAC REVIEW	SJR	SMT
REV.	DATE	DESCRIPTION	BY	CHK.

ISSUED FOR PERMITTING

HALEY WARD
 200 Griffin Rd., Unit 14
 Portsmouth, New Hampshire 03801
 603.430.9282
WWW.HALEYWARD.COM

PROPOSED 3 LOT SUBDIVISION
 20 CENTRAL AVENUE, PORTSMOUTH, NH 03801

GRADING & DRAINAGE PLAN

DATE	JUNE 2026	SCALE	1"=20'
DRAWN BY	SJR	DESIGNED BY	NMT
CHECKED BY	DJO	PROJECT No.	5010658.001
DRAWING No.	C103	REV.	0

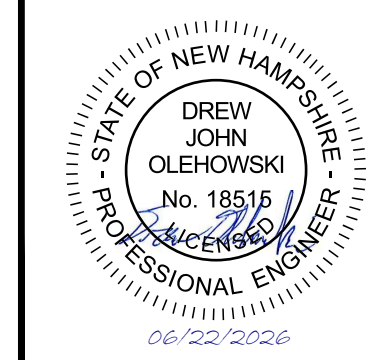

FILE LOCATION: P:\NH\61066\COREY_PROPERTY\501-20CENTRAL_AVE_PORTSMOUTH\ASSET\DWG_CAD_PLESCHE\18010668.dwg: C:\P\DWG_2026\06-22_11:21:AM

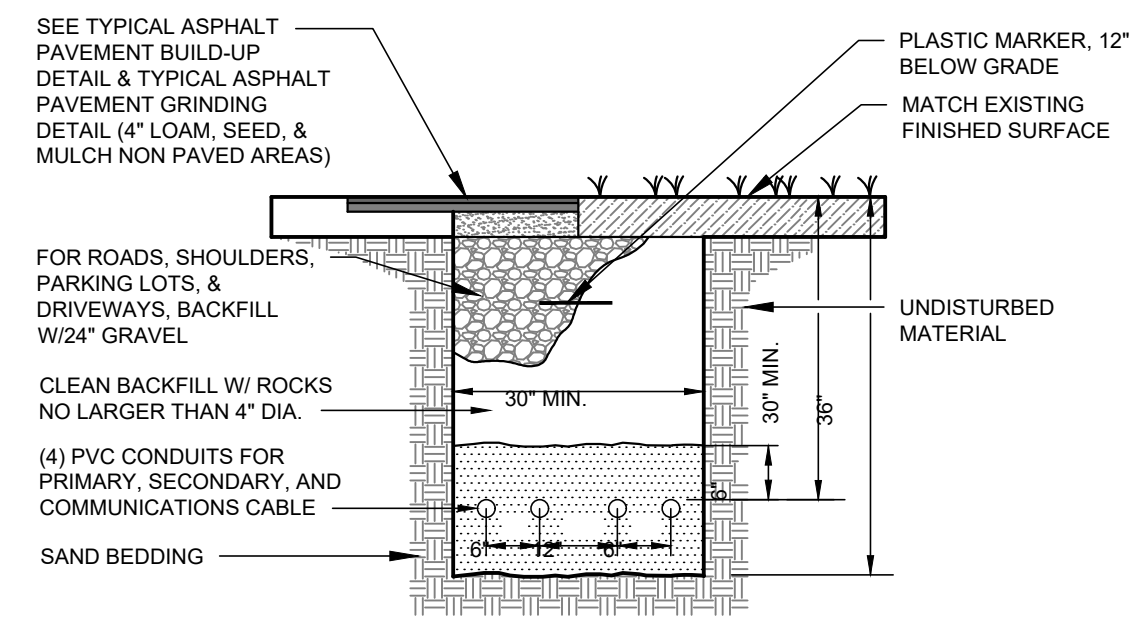

NOTES:
 1. SIZE, NUMBER, MATERIAL, AND ARRANGEMENT OF CONDUIT SHALL BE COORDINATED WITH INDIVIDUAL UTILITIES.
 2. ALL ELECTRICAL CONDUIT AND STRUCTURES SHALL BE WATER TIGHT.

TYPICAL UNDERGROUND UTILITY TRENCH DETAIL
 N.T.S.

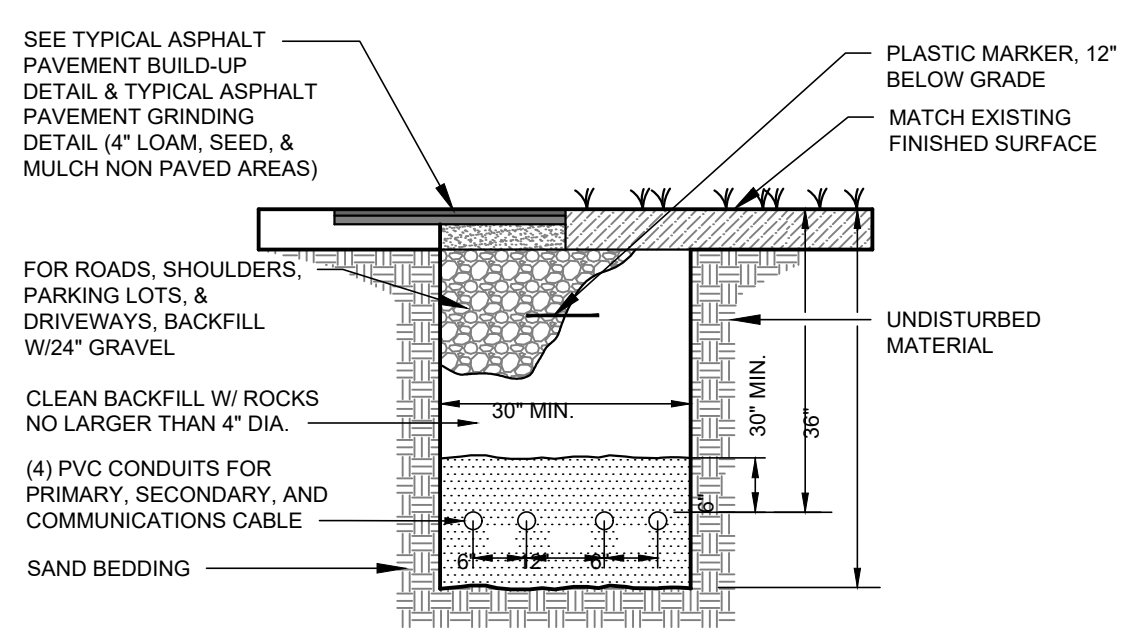

NOTES:
 1. SIZE, NUMBER, MATERIAL, AND ARRANGEMENT OF CONDUIT SHALL BE COORDINATED WITH INDIVIDUAL UTILITIES.
 2. ALL ELECTRICAL CONDUIT AND STRUCTURES SHALL BE WATER TIGHT.

TYPICAL UNDERGROUND UTILITY TRENCH DETAIL
 N.T.S.

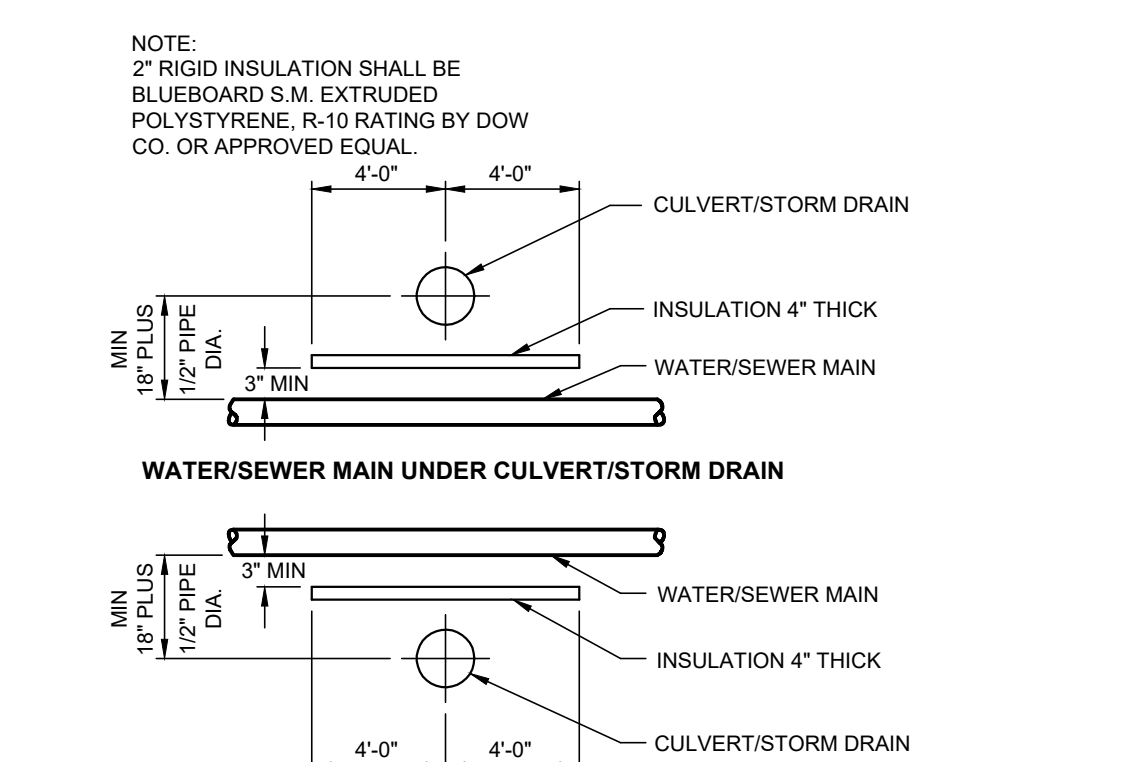

NOTE:
 2" RIGID INSULATION SHALL BE BLUEBOARD S.M. EXTRUDED POLYSTYRENE, R-10 RATING BY DOW CO. OR APPROVED EQUAL.

NOTES:
 1. 2" RIGID INSULATION SHALL BE BLUEBOARD S.M. EXTRUDED POLYSTYRENE, R-10 RATING BY DOW CO. OR APPROVED EQUAL.
 2. INSULATION TO BE 2 FEET WIDE FOR PIPES LESS THAN 6 INCHES IN DIAMETER AND 4 FEET WIDE FOR PIPES 6 INCHES IN DIAMETER AND LARGER, OR AS DIRECTED BY THE ENGINEER.

TYPICAL PIPE CROSSING INSULATION DETAIL
 N.T.S.

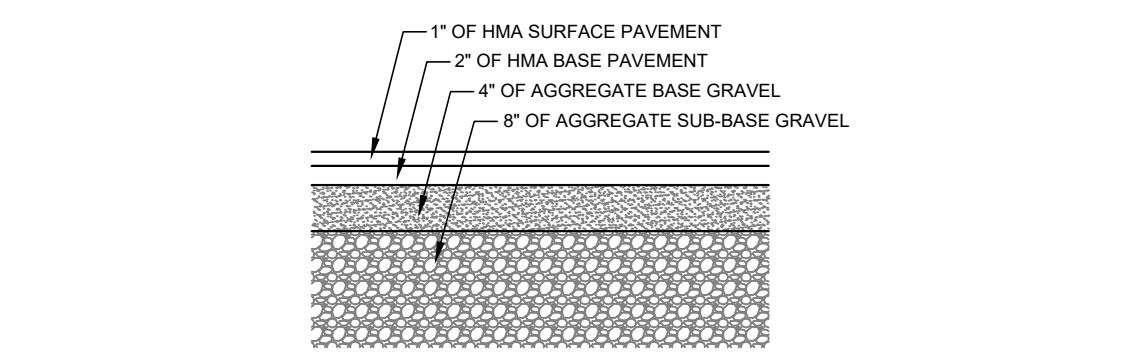

TYPICAL DRIVEWAY PAVING DETAIL
 N.T.S.

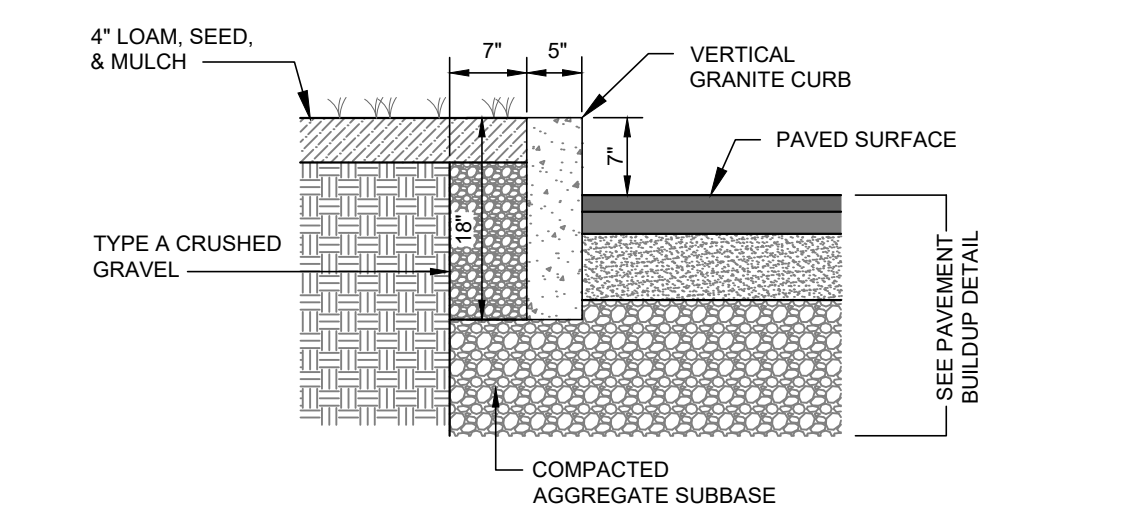

TYPICAL VERTICAL GRANITE CURB DETAIL (WHERE SHOWN)
 N.T.S.

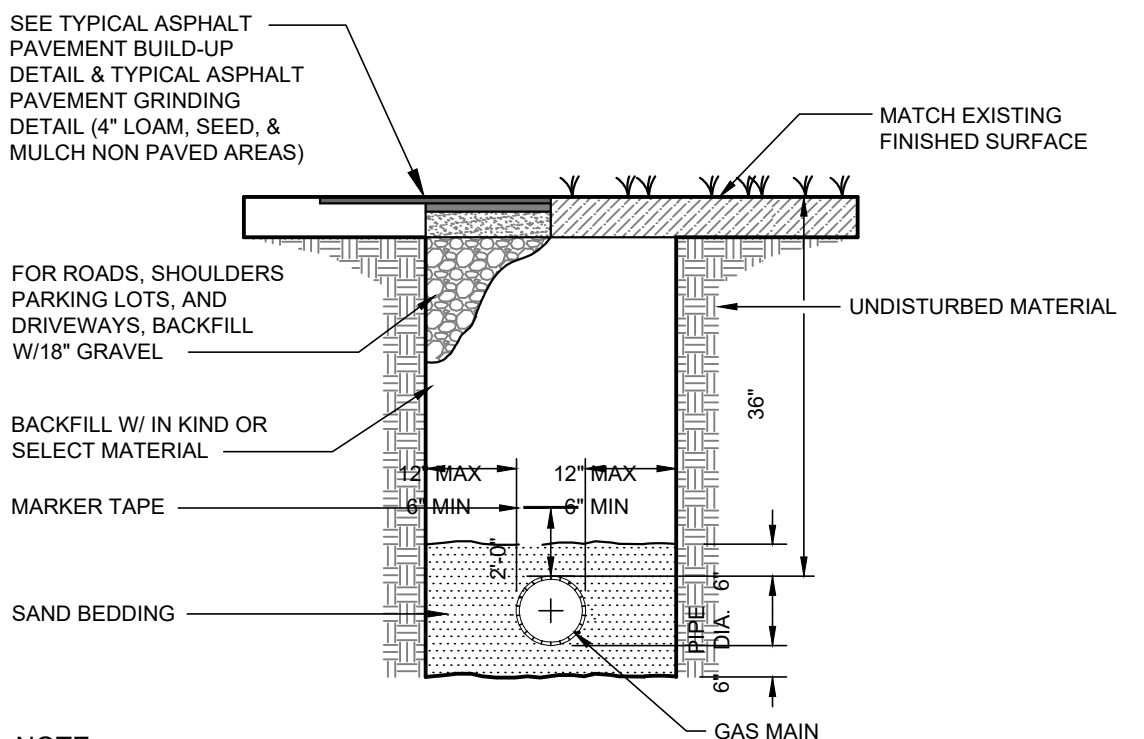

NOTE:
 1. COMPACT ALL GRANULAR MATERIAL AND BACKFILL TO 95%.
 2. SIDE CLEARANCE APPLICABLE TO BACKHOE OPERATIONS.

TYPICAL GAS TRENCH DETAIL
 N.T.S.

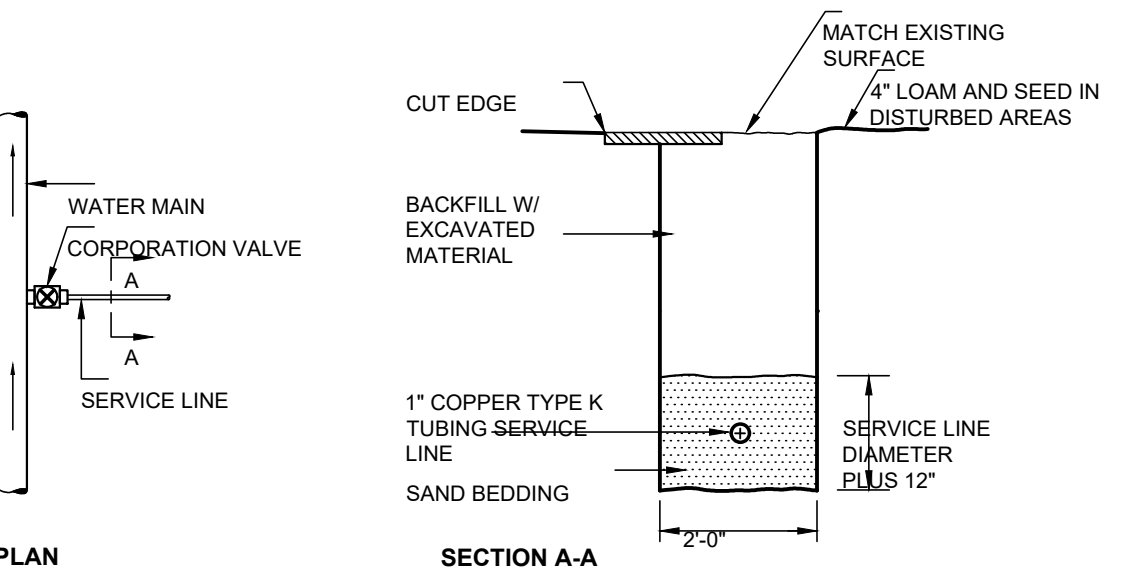
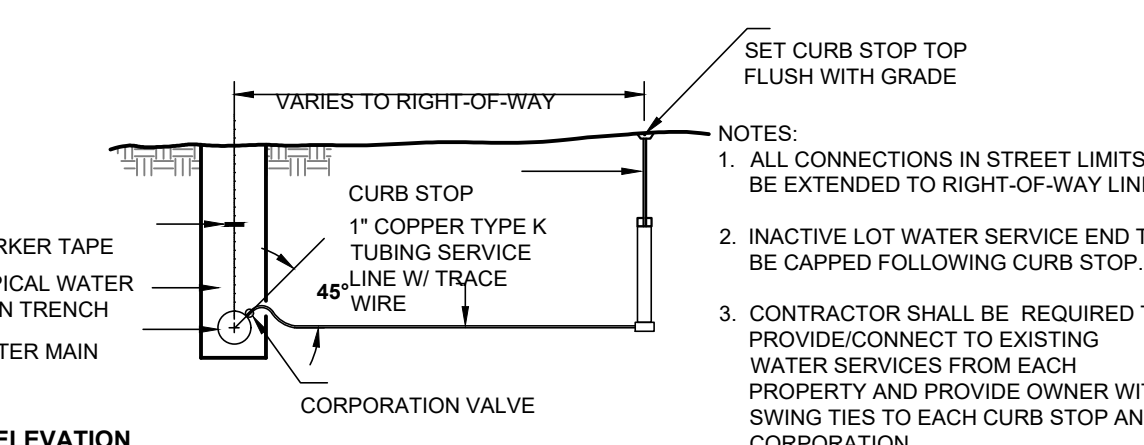

TYPICAL WATER SERVICE DETAIL
 N.T.S.

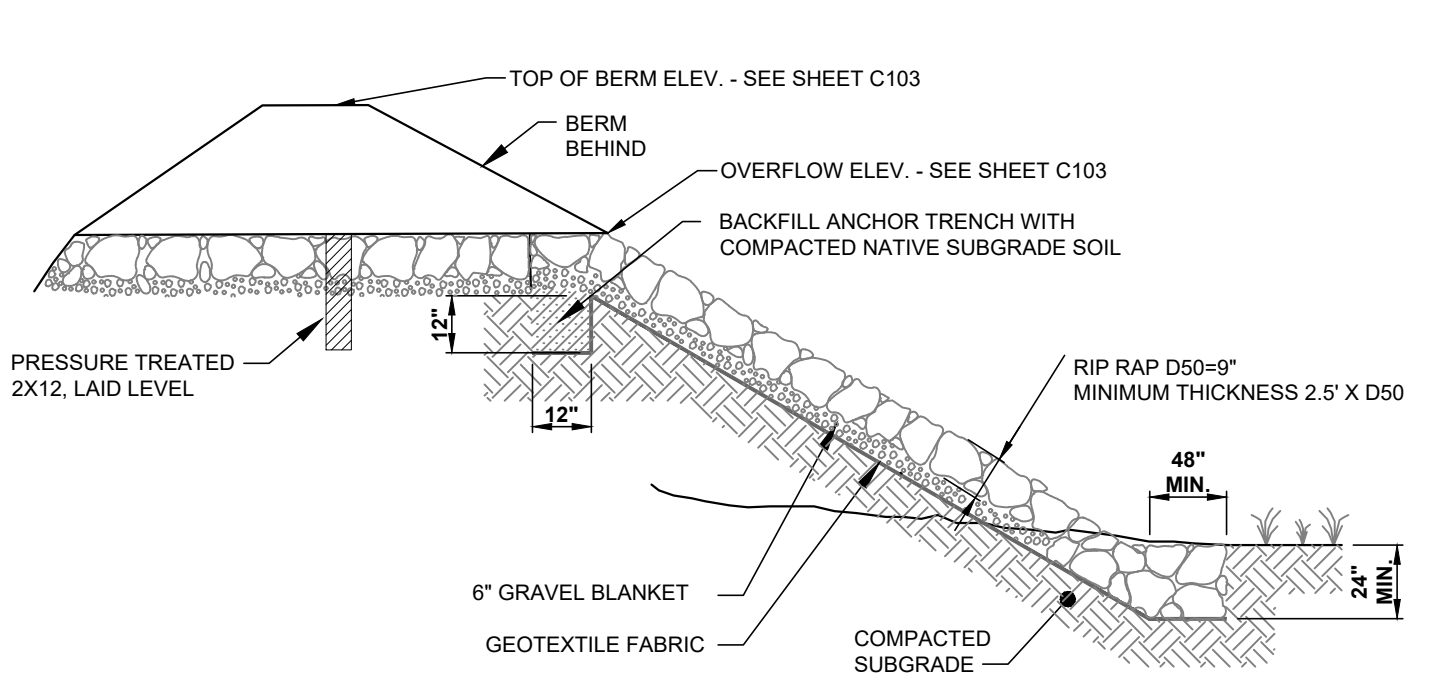

EMERGENCY SPILLWAY SECTION

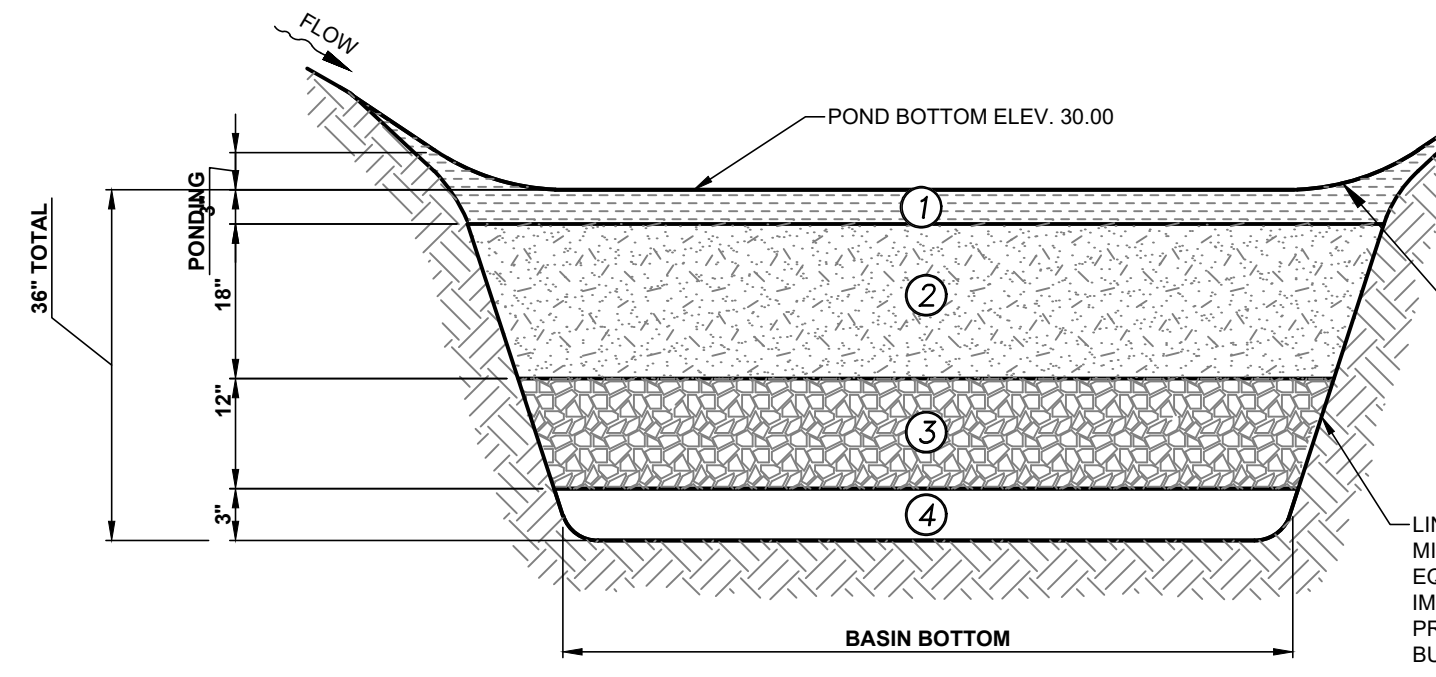

RAIN GARDEN SECTION

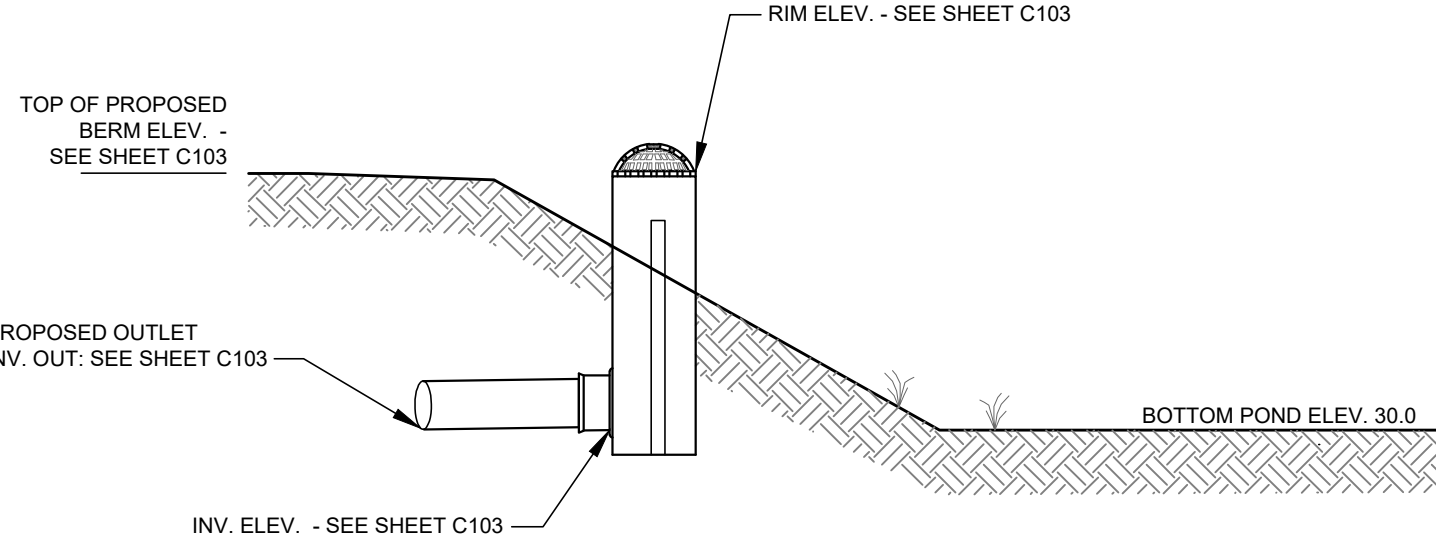

RAIN GARDEN PROFILE

RAIN GARDEN DETAIL
 N.T.S.

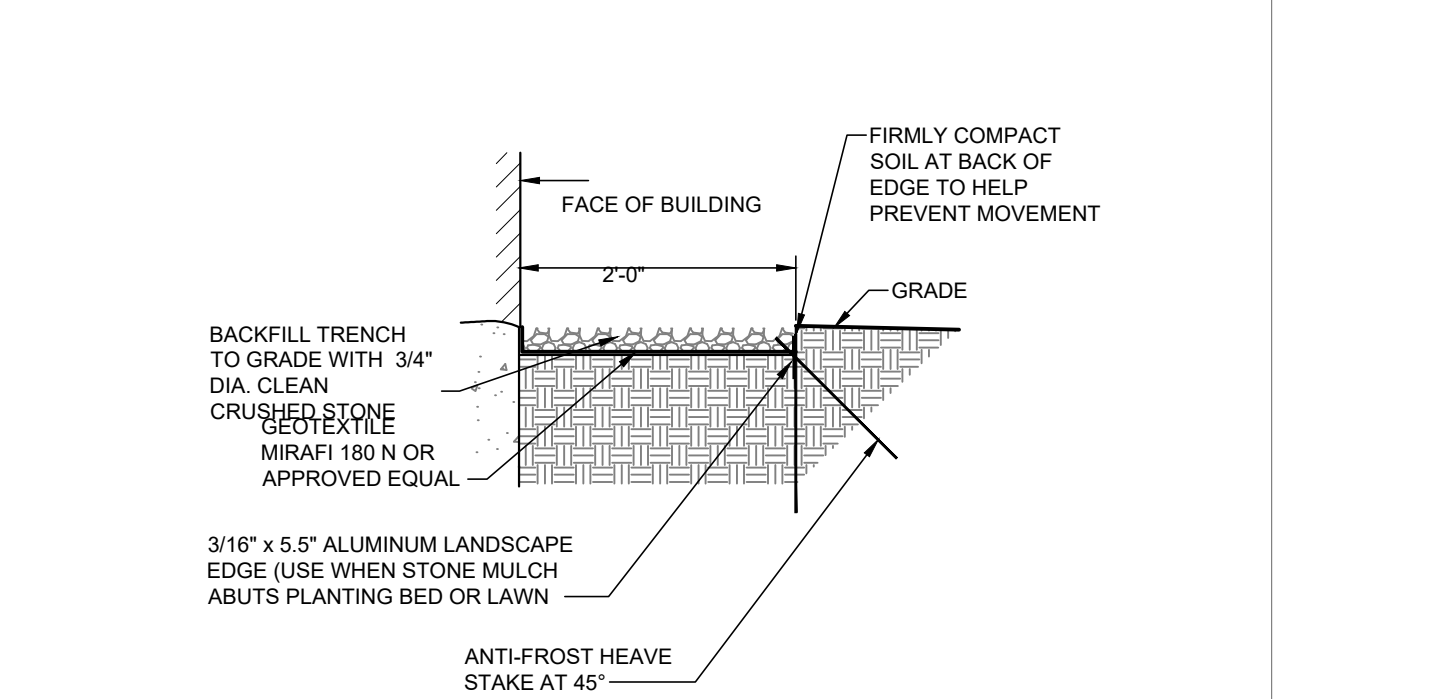

NOTE:
 EDGE TO BE BY SURE-LOC ALUMINUM EDGING CORP. OR APPROVED EQUAL.
 - MILL FINISH
 - 12" STAKES
 - ANTI-FROST HEAVE STAKE POCKETS AT 8" O.C.

DRIP EDGE DETAIL
 N.T.S.

RAIN GARDEN MEDIA											
①	MULCH/GROWING MEDIUM: GRASS SEED MIX A WITH LOAM										
②	SOIL FILTER LAYER: USE UNHSC BIORETENTION SOIL SPECIFICATIONS DATED FEBRUARY, 2017, 20% - 30% MULCH BY VOLUME, MIXED THOROUGHLY WITH LOAMY, COARSE SAND (70% - 80% BY VOLUME) MEETING THE FOLLOWING GRADATION:										
	<table border="1"> <thead> <tr> <th>SIEVE NO.</th> <th>% BY WEIGHT, PASSING</th> </tr> </thead> <tbody> <tr> <td>4</td> <td>100</td> </tr> <tr> <td>10</td> <td>95</td> </tr> <tr> <td>40</td> <td>10 - 25</td> </tr> <tr> <td>200</td> <td>0 - 5</td> </tr> </tbody> </table>	SIEVE NO.	% BY WEIGHT, PASSING	4	100	10	95	40	10 - 25	200	0 - 5
SIEVE NO.	% BY WEIGHT, PASSING										
4	100										
10	95										
40	10 - 25										
200	0 - 5										
③	0.75" - 1.5" CRUSHED STONE, WASHED.										
④	3/4" PEA GRAVEL										

BIORETENTION MAINTENANCE

SOILS:
 VISUALLY INSPECT AND REPAIR EROSION MONTHLY. USE SMALL STONES TO STABILIZE EROSION ALONG DRAINAGE PATHS. CHECK THE pH ONCE OR TWICE A YEAR. APPLY AN ALKALINE PRODUCT, SUCH AS LIMESTONE, IF NEEDED.

MULCH:
 REMULCH ANY VOID AREAS BY HAND AS NEEDED. EVERY 6 MONTHS, IN THE SPRING AND FALL, ADD A FRESH MULCH LAYER. ONCE EVERY 2 TO 3 YEARS, IN THE SPRING, REMOVE OLD MULCH LATER AFTER APPLYING NEW ONE.

PLANTS:
 IMMEDIATELY AFTER THE COMPLETION OF CELL CONSTRUCTION, WATER GRASS COVERING FOR 14 CONSECUTIVE DAYS UNLESS THERE IS SUFFICIENT NATURAL RAINFALL. ONCE A MONTH (MORE FREQUENTLY IN SUMMER), VISUALLY INSPECT VEGETATION FOR DISEASE OR PEST PROBLEMS. IF TREATMENT IS WARRANTED, USE THE LEAST TOXIC APPROACH. TWICE A YEAR, FROM MARCH 15TH TO APRIL 30TH AND OCTOBER 1ST TO NOVEMBER 30TH, REMOVE AND REPLACE ALL DEAD AND DISEASED VEGETATION CONSIDERED BEYOND TREATMENT. DURING TIMES OF EXTENDED DROUGHT, LOOK FOR PHYSICAL FEATURES OF STRESS (UNREVIVED WILTING, YELLOW, SPOTTED OR BROWN PATCHES ETC.). WATER IN THE EARLY MORNING AS NEEDED. WEED REGULARLY, IF NEEDED.

0	2026-06-22	ISSUED FOR TAC REVIEW	SJR	SMT
REV.	DATE	DESCRIPTION	BY	CHK.

ISSUED FOR PERMITTING

HALEY WARD
 200 Griffin Rd., Unit 14
 Portsmouth, New Hampshire 03801
 603.430.9282

PROPOSED 3 LOT SUBDIVISION
 20 CENTRAL AVENUE, PORTSMOUTH NH

SITE DETAILS

DATE	JUNE 2026	SCALE	NTS
DRAWN BY	SJR	DESIGNED BY	NMT
CHECKED BY	DJO	PROJECT No.	5010658.001
DRAWING No.	C502	REV.	0



FILE LOCATION: P:\184510658\CORETY_PROPERTIES\5010658\20-CENTRAL_AVE_PORTSMOUTH\184510658\CAD_FILES\CIVIL\184510658\001_C502.DWG, 2026-06-22, 11:21 AM

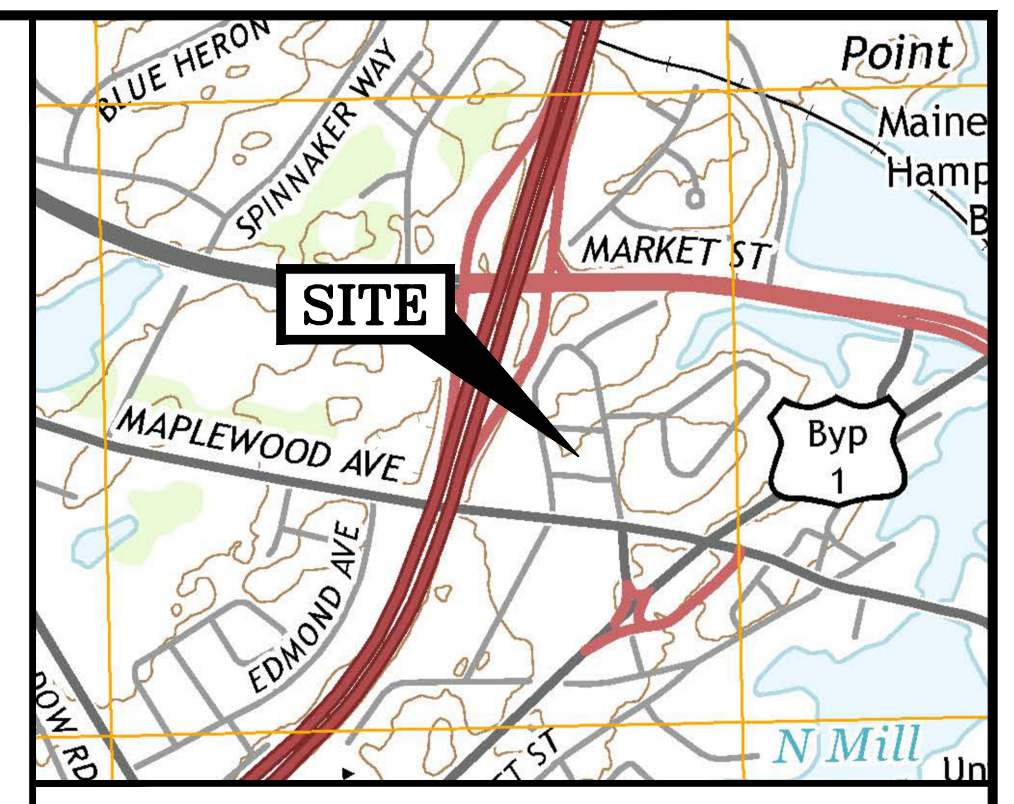

LOCATION MAP SCALE: 1" = 1,000'

PRE LEGEND:

	PROPERTY LINE
	WATERSHED BOUNDARY LINE
	WATERSHED DESIGNATION
	TIME OF CONCENTRATION FLOW PATH
	SUMMATION POINT

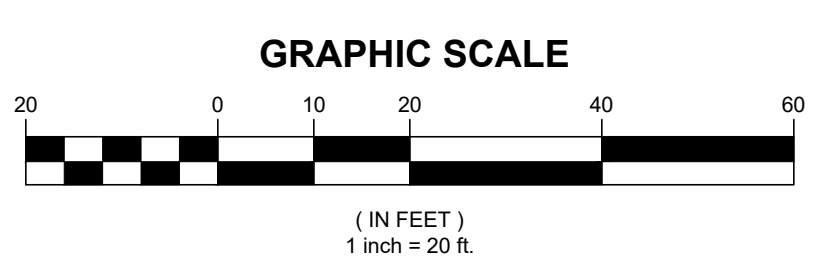
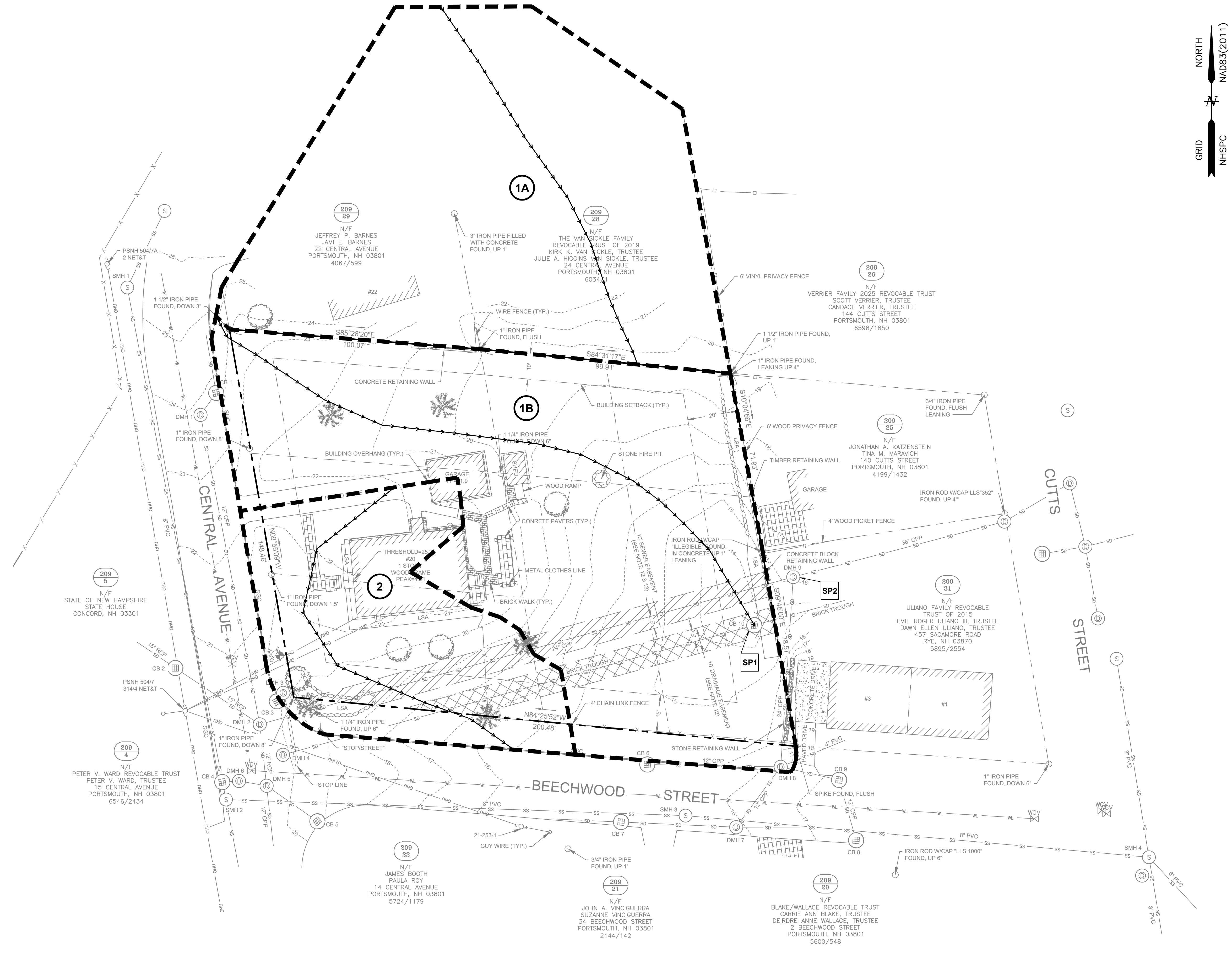

0	2026 05 18	ISSUED FOR TAC	SJR	SMT
REV.	DATE	DESCRIPTION	BY	CHK.
DRAWING ISSUE STATUS				
ISSUED FOR PERMITTING				
		HALEY WARD		
WWW.HALEYWARD.COM		200 Griffin Rd., Unit 14 Portsmouth, New Hampshire 03801 603.430.9282		
PROPOSED 3 LOT SUBDIVISION 20 CENTRAL AVENUE, PORTSMOUTH, NH 03801				
PRE-DEVELOPMENT HYDROLOGY PLAN				
DATE JUNE 2026		SCALE 1"=20'		
DRAWN BY NMT	DESIGNED BY NMT	CHECKED BY DJO		
PROJECT No. 5010658.001		DRAWING No. C701		
		REV. 0		

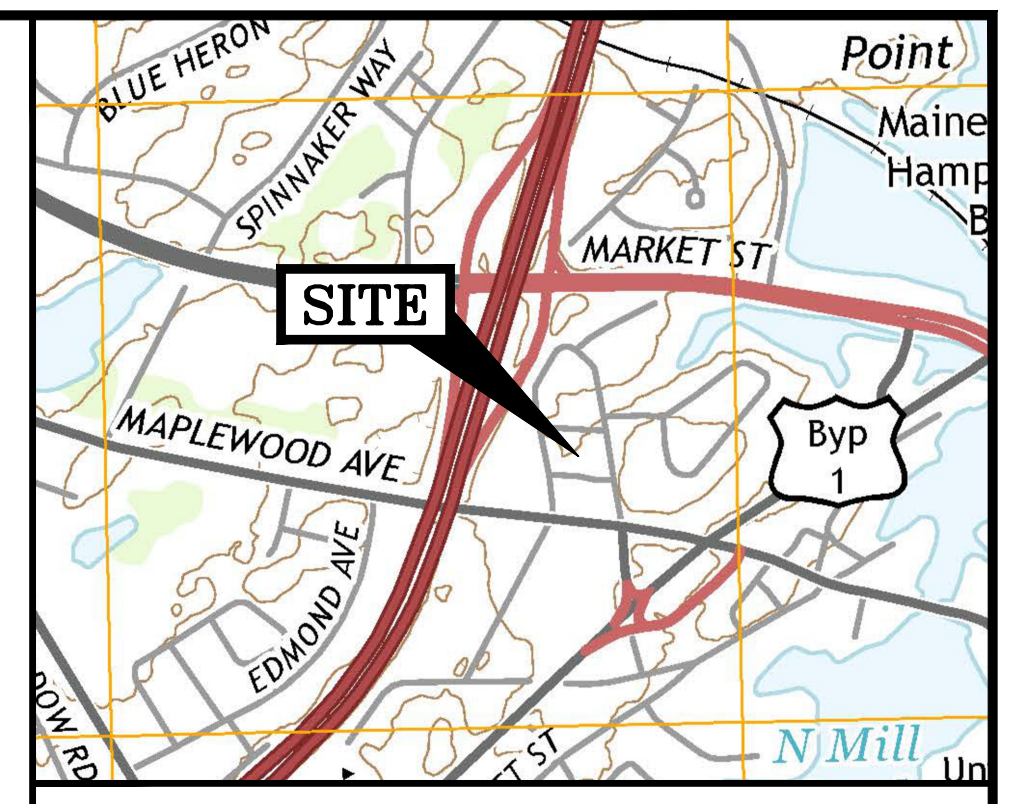

LOCATION MAP SCALE: 1" = 1,000'

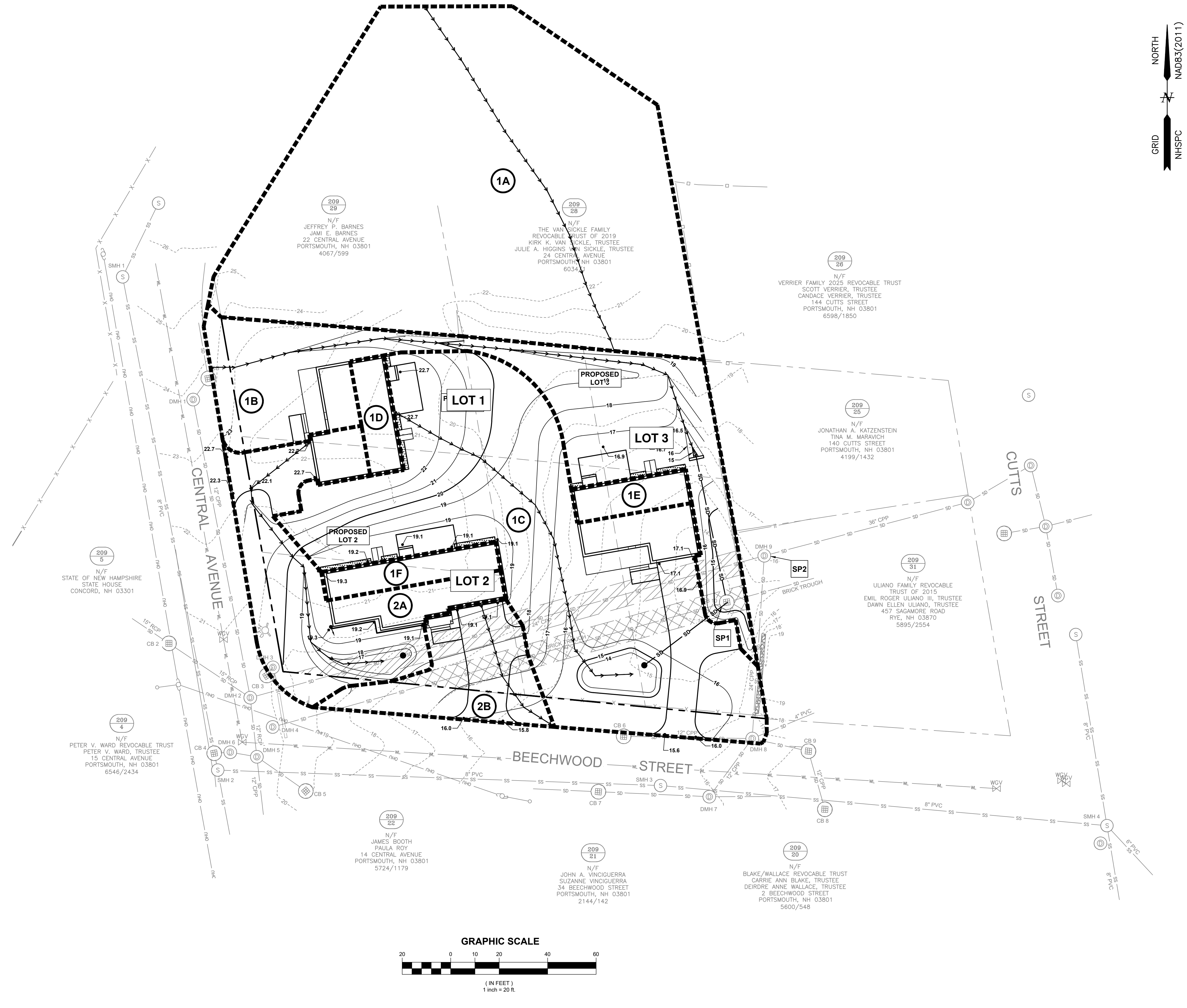
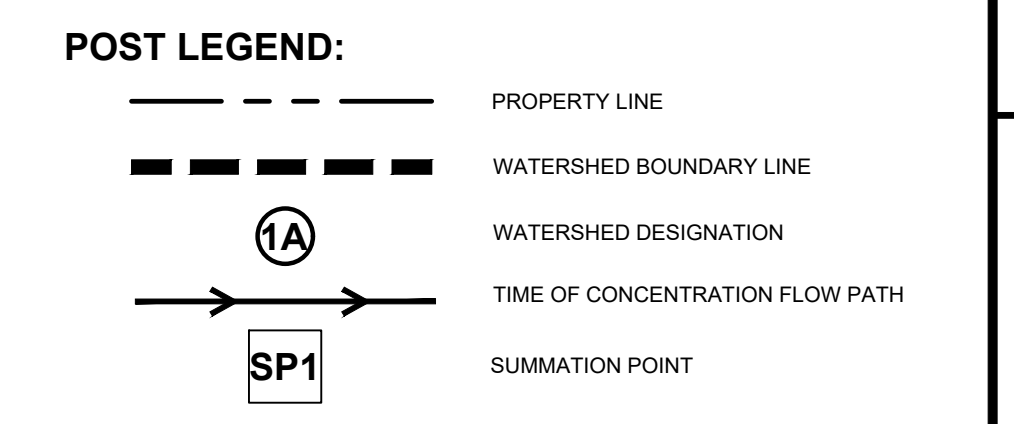
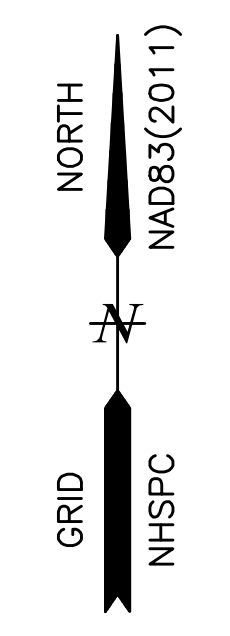

209 29
N/F
JEFFREY P. BARNES
JAMI E. BARNES
22 CENTRAL AVENUE
PORTSMOUTH, NH 03801
4067/599

209 28
N/F
THE VAN SICKLE FAMILY
REVOCABLE TRUST OF 2019
KIRK K. VAN SICKLE, TRUSTEE
JULIE A. HIGGINS VAN SICKLE, TRUSTEE
24 CENTRAL AVENUE
PORTSMOUTH, NH 03801
6034/341

209 26
N/F
VERRIER FAMILY 2025 REVOCABLE TRUST
SCOTT VERRIER, TRUSTEE
CANDACE VERRIER, TRUSTEE
144 CUTTS STREET
PORTSMOUTH, NH 03801
6598/1850

209 25
N/F
JONATHAN A. KATZENSTEIN
TINA M. MARAVICH
140 CUTTS STREET
PORTSMOUTH, NH 03801
4199/1432

209 31
N/F
ULIANO FAMILY REVOCABLE
TRUST OF 2015
EMIL ROGER ULIANO III, TRUSTEE
DAWN ELLEN ULIANO, TRUSTEE
457 SAGAMORE ROAD
RYE, NH 03870
5895/2554

209 5
N/F
STATE OF NEW HAMPSHIRE
STATE HOUSE
CONCORD, NH 03301

209 4
N/F
PETER V. WARD REVOCABLE TRUST
PETER V. WARD, TRUSTEE
15 CENTRAL AVENUE
PORTSMOUTH, NH 03801
6546/2434

209 22
N/F
JAMES BOOTH
PAULA ROY
14 CENTRAL AVENUE
PORTSMOUTH, NH 03801
5724/1179

209 21
N/F
JOHN A. VINGIGUERRA
SUZANNE VINGIGUERRA
34 BEECHWOOD STREET
PORTSMOUTH, NH 03801
2144/142

209 20
N/F
BLAKE/WALLACE REVOCABLE TRUST
CARRIE ANN BLAKE, TRUSTEE
DEIRDRE ANNE WALLACE, TRUSTEE
2 BEECHWOOD STREET
PORTSMOUTH, NH 03801
5600/548

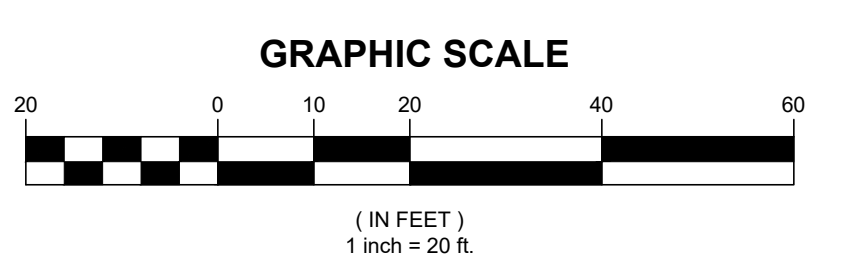

0	2026 05 18	ISSUED FOR TAC							
REV.	DATE	DESCRIPTION							
DRAWING ISSUE STATUS									
ISSUED FOR PERMITTING									
		HALEY WARD							
WWW.HALEYWARD.COM		200 Griffin Rd., Unit 14 Portsmouth, New Hampshire 03801 603.430.9282							
PROPOSED 3 LOT SUBDIVISION									
20 CENTRAL AVENUE, PORTSMOUTH, NH 03801									
PRE-DEVELOPMENT HYDROLOGY PLAN									
		DATE	APRIL 2026	SCALE	1"=20'				
		DRAWN BY	NMT	DESIGNED BY	NMT	CHECKED BY	DJO		
		PROJECT No.	5010658.001			DRAWING No.	C702	REV.	0