



200 Griffin Road, Unit 3, Portsmouth, NH 03801
Phone (603) 430-9282 Fax 436-2315

22 February, 2024

Peter Stith, TAC Committee Chair
City of Portsmouth
1 Junkins Avenue
Portsmouth, NH 03801

RE: Submission for Conditional Use Permit and Site Plan Approval at 581 Lafayette Road; Mixed Use Development; Tax Map 229 Lot 8B

Dear Mr. Stith and TAC Members:

On behalf of Atlas Common, LLC (Owner) we submit the attached Plans and additional supporting material for the above-mentioned project. The revisions were based upon the comments from the February 6, 2024, Technical Advisory Committee meeting. The project consists of the addition of residential units (including 20% of the Units as Workforce Housing) at 581 Lafayette Road with two new building additions with the associated and required site improvements. The site is currently developed with two restaurants. The re-development will include creating an additional car park below first floor building level. The project specifics are as follows:

Project Summary

The project is located at 581 Lafayette Road and is proposed additions to an existing building. The building was renovated when the site was changed from a Cinema to the Tuscan Restaurant – Tuscan Marketplace in 2016. The site is at the corner of Lafayette Road and Ledgewood Drive, and is known as Tax Map 229, Lot 8B. The lot is a 98,124 square foot parcel with frontage on both streets. The existing conditions plan shows the current site features. The Tuscan Restaurant moved to downtown Portsmouth, and that portion of the site was re-purposed to a restaurant with golf simulators, known as Tour. The Tuscan Marketplace closed, but recently the Tuscan Marketplace space was converted to another restaurant with some outside seating.

The property is in the Gateway Neighborhood Mixed-Use District - G1. The purpose of the district is to support the goals of the cities Master Plan and Housing Policy. The aim of the policy is to encourage walkable, mixed-use development, and continued economic vitality in the cities primary gateway areas. The district seeks to ensure that new developments complement and enhance the surroundings and provide housing stock that is suitable for changing demographics and accommodate the housing needs of the city's current and future workforce. This plan works towards that standard by adding to the existing structure and

creating a mixed-use building with 72 new dwelling units. The proposed uses; being restaurant use and dwelling units (multi-family residential) are both allowed uses in the district.

Proposed Development

The proposed building has been edited in footprint since the previous TAC submission, made smaller along the Ledgewood Road side of the development. Currently the project proposes additions that are set back 39 feet from Ledgewood Drive, 39 feet from Lafayette Road, 23 feet from the southerly abutting property line, and 39 feet from the easterly abutting property line. The proposed building additions maintain the ability for the free flow of traffic around the proposed additions, as required by deed restrictions and easements on the property. The building height is intended to comply with section 10.5 B 22.10, with incentives as allowed under the section. Regarding the special 90-foot setback requirement on Lafayette Road, the project is in a location where there is a significant open space in front of the subject parcel. This open space was created when the Lafayette Road, Route 1 Bypass intersection was restructured around 2011. That relocation of the intersection created this large open space area in front of the lot, which meets the special setback requirement for this parcel.

The submitted site plan shows the impervious surface calculations for the proposed development. When the site was redeveloped to the Tuscan Restaurant and Marketplace, the impervious surface coverage was allowed to increase under a Variance, up to coverage which maintained 16.5% open space. The submitted site plan proposes coverage of 80.1% with the reworking of some hardscape spaces to porous surfaces. The plan open space calculations show that when the proposed open space is adjusted for sidewalk percentage allowed to be included in open space, the proposed site open space is 21.8%, and is now conforming.

Project Parking

First floor parking spaces are accessed from driveways to the parking areas at first floor level, as shown on the site plan and parking plan. Underground parking is accessed from a driveway ramp on the north side of the proposed structure off Ledgewood Drive. The total parking provided meets the ordinance requirements of the city of Portsmouth.

There is an existing encroachment of approximately 30 parking spaces (as adjusted to current code for landscape islands) in a small portion of land owned by the State of New Hampshire along Route 1. The encroachment results in parking spaces being approximately zero to seven feet onto property owned by the State of New Hampshire. The land area involved is approximately 1200 square feet. This parking encroachment has existed for many decades and the encroachment is shown on the State of New Hampshire plans for the widening of Route 1 which occurred when the overpass over Route 1 was eliminated in favor of the traffic lights and traffic lanes that exist today.

This encroachment has been accurately identified on prior site plan(s) that were approved by the City of Portsmouth Planning Board in 2015 for the Tuscan Kitchen and Marketplace conversion of the movie theater, without any requirement to bring the encroachment into compliance. The applicant proposes no changes to those parking spaces (other than adding code compliant landscape islands and a space for a new transformer) and therefore requests they be left as is in their nonconforming use.

As support for leaving the parking encroachment as-is, the Applicant proposes to pay the cost and reconfigure that immediate area, when and if required by the State of New Hampshire, in accordance with the “Alternative Parking Layout” as shown on Sheet C4 of the plan set. The proposed site plan contains a total of 181 parking spaces. If that area is required to be vacated and parking spaces installed according to the Alternative Parking Layout, then a total of 7 parking spaces would be lost. Any loss of parking spaces is easily provided for in the cross-parking easement recorded in the Rockingham Registry of Deeds with the abutting property owner.

Attached is a copy of the NHDOT Highway plans showing the relationship between the right-of-way line and the pavement at the time of the improvement project. In addition, the deeded right to shared parking is also included in the submission.

Project Drainage

The existing drainage consists of some roof drain connections as well as some parking lot connections to the drainage network, which flow off-site. The property drainage is divided into two watersheds, one that flows to the south along the front of the adjacent mall and the other flows to the south along the back of the adjacent mall and across the adjacent property. The intent of this design is to maintain those flow directions and re-purpose the drainage in accordance with the proposed site addition roof drains. The roof drains will replace the catch basins and direct the water in the same direction as the previous approved design, with the same contributing area. The plan calls for the addition of a Jellyfish Filter, which will provide more advanced treatment than the existing on-site mechanical separator.

Proposed Public Realm

Under Section 10.5B74.12 the development standards of that section require that there is a Public Realm Improvement associated with the development. The project proposes an off-site sidewalk connection to Portsmouth High School and an improved basketball facility with seating at the end of Ledgewood Drive (all on city property) as this component. The development team is in ongoing discussions with the School Department regarding those improvements. Concept improvements are included in the plan set. As discussions are ongoing at this time the submission includes a Draft MOU. In the MOU the Developer would be responsible for planning and building the project. Since the design needs to be completed with the input of the stakeholders and detailed cost estimates developed, we hereby request that the project be moved along to the Planning Board with a condition that the completion of this process occur at a later date.

Project Community Space

The Community Space on the site consists of an Outdoor Dining Café and a Pocket Park. The Pocket Park includes a proposed public bike rack in close proximity to the existing bus stop. The Outdoor Dining Café provides an area of outside use for the public, as well as the building residents, which will be fitted with tables and chairs. The area includes an outdoor fireplace. The space dedicated to the existing restaurants for outdoor dining is not included in the Community Space Easement area. The required 10% of lot area as Community Space is not provided on site. The proposed total is 7.6%, therefore relief from the Ordinance, which is allowed to be granted by the Planning Board, will be requested. The Developer has met

with city staff and has identified areas adjacent to the on-site Community Space that can be expanded and enhanced. Those spaces will be landscaped and maintained by the developer and the area of the space, and the proposed planting is identified in the plan set.

Conditional Use Permit Development Standards

The development is consistent with the Portsmouth Master Plan. The project has been designed under Article 5B Gateway Neighborhood Mixed Use Districts, Section 10.5B34.80, Mixed-Use Building and Section 10.5B42.20, Mixed-Use Development. The development standards of that section requires relief from the Planning Board for a Conditional Use Permit where development deviates from the strict standards.

In the density section of the ordinance this development would be allowed up to 24 units per structure. This project proposes a Conditional Use Permit for a density bonus as allowed in section 10.5B72 for two buildings with 36 units in each building. This increased housing density is allowed with an incentive. In order to be eligible for the bonus incentive the development shall include workforce housing. The intent of this development is to provide workforce housing as defined by the Portsmouth Ordinance in the amount of 20% of the dwelling units, or 15 units.

We believe that under section 10.5B74.30 the Planning Board is authorized to grant modifications to the standards of the section. Modifications to the Community Space requirement will be requested from the Planning Board in this application. We believe that the modifications to the strict ordinance interpretations are consistent with the purpose and intent set forth in the Gateway Neighborhood Mixed-Use District section. The site offers 7.6% Community Space where 10% is required.

Development Site Conditional Use Permit

Under Section 10.5B41.10 Development Site Standards are allowed by Conditional Use Permit approval from the Planning Board. A development site is a development including more than one principal building or building type. As the proposed development includes more than one principal building and the proposed Public Realm improvements are proposed on a separate lot, a CUP to allow the use of the Development Site Standards is being requested for this proposed project.

Conditional Use Permit Criteria

Under Section 10.5B41.10 the following addresses how the Project warrants the granting of a Conditional Use Permit for a Development Site by satisfying the following four (4) criteria for approval in Section 10.5B43.10 of the Zoning Ordinance:

1) The development project is consistent with the Portsmouth Master Plan. **The Project is consistent with several goals identified in the Master Plan.**

Goal 1.2 is to encourage walkable mixed-use development along existing commercial corridors. The project will promote walking and bicycling by expanding the sidewalk

network and connecting, through the Public Realm off-site improvement, the Lafayette Road sidewalk network to the Portsmouth High School property.

The plan also creates public community space consisting of a Pocket Park and an Outdoor Café. The plans identify public bicycle storage spaces in close proximity to a Coast Bus Stop.

Goal 2.1 is to ensure that new development complements and enhances its surroundings. The proposed residential building additions will add residential use to the adjacent commercial development. This creates the Mixed-Use environment that the Master Plan identifies as essential to the maintenance of a vibrant neighborhood. Residential uses expand on the commercial retail and restaurant uses located in the Lafayette Plaza and surrounding parcels. The Gateway Corridor was identified as an area where residential expansion is encouraged.

(2) The development project has been designed to allow uses that are appropriate for its context and consistent with the City’s planning goals and objectives for the area. **The project provides much needed housing.**

The development will be complementary to the abutting uses. The proposed use is allowed within the zone. Creating a mixed-use environment will serve to ensure the maintenance of a vibrant neighborhood. The introduction of Workforce Housing provides much needed relief to the need for affordable housing.

(3) The project includes measures to mitigate or eliminate anticipated impacts on traffic safety and circulation, demand on municipal services, stormwater runoff, natural resources, and adjacent neighborhood character. **The project does not create excess demand for city services nor change the essential character of the neighborhood.**

The Project will generate peak traffic during different times than the surrounding commercial uses on Lafayette Road. The existing large traffic volumes will mask any impacts. The drainage design will increase treatment to stormwater runoff with the use of a more advanced stormwater filtration treatment practice. The addition of residential use will be complementary to the abutting commercial uses. City infrastructure is in place to accommodate the development.

(4) The project is consistent with the purpose and intent set forth in Section 10.5B11. **The project supports the Master Plan goals in a significant way by providing affordable housing and creating a mixed-use development.**

Section 10.5B11.10 states that the purpose of Article 5B is to implement and support the goals of the City’s Master Plan and Housing Policy to encourage walkable mixed-use development and continued economic vitality in the City’s primary gateway areas, ensure that new development complements and enhances its surroundings, provide housing stock that is suited for changing demographics, and accommodate the housing needs of the City’s current and future workforce. Section 10.5B11.20 sets forth the intent of the standards. The project meets the standards and will create a mixed-use development that will help to create a vibrant neighborhood. The

introduction of Workforce Housing provides much needed relief to the need for affordable housing in an area outside of the downtown core, with easy access to abutting retail and public transportation. The project will be the other bookend from the recently approved residential development at the other end of this commercial strip.

Project Site Details

The complete development plan is shown on the attached Proposed Site Plans and the Supplemental material submitted herewith.

Requested Approval

We look forward to TAC review of this submission and the Committees feedback on the proposed design. We hereby request that the project be approved and allowed to move forward to the Planning Board.

Sincerely,

A handwritten signature in black ink, appearing to read 'J. Chagnon', with a long horizontal flourish extending to the right.

John Chagnon, PE; Ambit Engineering – Haley Ward

P:\NH\5010156-McNabb_Properties\1397.03-Lafayette Rd., Portsmouth-JRC\2023 Site Plan 1397.03\Applications\Portsmouth Site Plan\581 Lafayette TAC Submission 2-22-24.doc



LCHIP	ROA646155	25.00
RECORDING		22.00
SURCHARGE		2.00

WARRANTY DEED

JOHN GALT, LLC, a New Hampshire limited liability company with a mailing address of 3 Pleasant Street, Suite 400, Portsmouth, New Hampshire 03801 ("Grantor") for consideration paid grants to **ATLAS COMMONS, LLC**, a New Hampshire limited liability company with a mailing address of 3 Pleasant Street, Suite 400, Portsmouth, New Hampshire 03801 ("Grantee") **WITH WARRANTY COVENANTS**

THE FOLLOWING DESCRIBED PREMISES:

1. A certain tract or parcel of land, together with any buildings or improvements thereon, situate in Portsmouth, County of Rockingham and State of New Hampshire, bounded and described as follows:

Beginning at a point in the Easterly sideline of Lafayette Road at the Northwesterly corner of the parcel herein described and at land of the City of Portsmouth; thence running North 81°43 East by City of Portsmouth land, two hundred eighty-one and seven tenths (281.7) feet to a corner at land of Ledgewood Manor Associates; thence turning and running South 5°56' West two hundred forty-six and thirty-one hundredths (246.31) feet, South 15°05'30" West fourteen and twenty-one hundredths (14.21) feet, South 07°12' West seventy-two and no hundredths (72.00) feet, South 48°45' East thirty-three and thirty-two hundredths (33.32) feet and South 39°04' East seventy-five and seven hundredths (75.07) feet, all by land of Ledgewood Manor Associates to a corner of land now or formerly of William N. Genimatas; thence turning and running North 84°04' West three hundred thirty and forty hundredths (330.40) feet by land of said Genimatas to Lafayette Road; thence turning and running North 05°56' East two hundred thirty-nine and thirty-nine hundredths (239.39) feet and North 05°31' West ninety-six and two tenths (96.2) feet by said Lafayette Road to the point of beginning. Containing 2.25 acres, more or less.

2. Together with the perpetual right to use in common with DLR, Inc., and William N. Genimatas, their heirs, devisees, successors and assigns, the Lafayette Road entrance-exit way as developed by DLR, Inc., (formerly MDL, Inc.) near the southwest corner of the land retained by Genimatas, together with the perpetual right hereby granted to grantees,

their heirs, devisees and assigns, to use in common with said DLR, Inc., and Genimatas, their heirs, devisees, successors and assigns, the other Lafayette Road entrance-exit ways on the DLR, Inc. and the Bowl-O-Rama lots adjoining the premises hereby conveyed.

3. Subject to, and with the benefit of mutual parking rights in common with said DLR, Inc., and said Genimatas respecting this lot and the adjoining Bowl-O-Rama and DLR, Inc., lots, namely and respectively, that said DLR, Inc., Genimatas and Robbins shall have free parking as may be necessarily available on any of these three parcels of land, and such parking rights for each of them in each other's adjacent land shall be mutually interchangeable, for said Genimatas, DLR, Inc., and said Robbins, their respective heirs, devisees, successors and assigns, such mutual parking rights and benefits to extend to any other persons or corporations and any other lands and premises, which said Genimatas, said Robbins, MGR Realty and/or MGR Realty, Inc., may have heretofore conveyed and reserved such rights, benefits or privileges. The foregoing parking rights shall not limit or restricts the rights of the owners of the said lots to construct buildings or additions to same, upon the said lots, provided no unreasonable imposition of owner's parking is caused the abutters by such buildings or additions thereto.
4. Also being conveyed with the benefit of, a certain right of way in common with others, including Petzold, et al, and Ledgewood Manor Associates on the Southerly part of the DLR, Inc., Lot #3, second lot south of this lot, said right of way being also subject to a restriction against the erection of a barrier, fence or other obstruction on either side of said right of way as it runs to Lafayette Road, all as per agreement acknowledged on July 23, 1973, recorded in Rockingham Registry of Deeds, Book 2209, Page 1400.
5. The foregoing premises are further conveyed subject to, and with the benefit of, a perpetual easement for a roadway thirty (30) feet in width extending from Lafayette Road on the South, adjacent to land of Petzold, running thence along the southerly and easterly boundary of the DLR (former Tower Restaurant) Lot of 1.92 acres, the easterly boundary of the Genimatas (Bowl-O-Rama) Lot of 2.82 acres, and the easterly boundary of the Robbins (Jerry Lewis Cinema) Lot of 2.25 acres, as shown on plan of "Subdivision of Land, Portsmouth, N.H., for Genimatas and Robbins" dated November 1978, Revised June 7, 1979 which roadway easement is reserved for use in common of, and the benefit in common of, William N. Genimatas, Henry J. Robbins, Joan M. Robbins, and DLR, Inc., and their respective heirs, devisees, successors and assigns. Owners of Lots #1, 2, and 3 in said Subdivision agree that they will equally contribute to development and maintenance of such thirty (30) foot right-of-right as a passable gravel way, excluding winter maintenance such as snow plowing and clearing way of snow, ice, slush or water.
6. The premises hereby conveyed (the "Premises") shall be SUBJECT TO the restriction (this "Use Restriction") that the business of a movie theater shall not be conducted or maintained upon the Premises or any portion thereof for a period of twenty (20) years from October 10, 2007, the date of the recording of the deed from Canavan Properties, LLC, to MANI Properties, LLC recorded in the Rockingham County Registry of Deeds at Book 4851, Page 526 (the "Restriction Term"). By the acceptance of this Deed, the within grantee agrees to be bound by this Use Restriction. This Use Restriction shall run with the land and be binding upon the within grantee, the within grantee's successor and

assigns, and the Premises and every part thereof for the duration of the Restriction Term; and in each and every Deed to the Premises or any portion thereof given during the Restriction Term, the then grantor shall undertake to insert a clause referring to this Use Restriction. This Use Restriction is for the benefit of Hoyts Cinemas Corporation, a Delaware Corporation, and its subsidiaries, and their respective successors and assigns (collectively, "Hoyts"), and Hoyts, as a former tenant of the Premises and for consideration paid to the within grantor, shall have the right to enforce this Use Restriction.

7. A portion of the above premises, more particularly bounded and described as set forth below, is subject to a perpetual easement for the installation and maintenance of utility lines:

A certain tract or parcel of land situate on the Easterly side of Lafayette Road, Portsmouth, Rockingham County, New Hampshire, described as follows:

Beginning at a point in the Easterly sideline of Lafayette Road at the Northwest corner of the parcel herein described and the Southwest corner of land of the City of Portsmouth; thence running North $81^{\circ}43'$ East two hundred eighty-one and seven tenths (281.7) feet to an iron pipe at land now or formerly of Ledgewood Manor Associates; thence turning and running South $05^{\circ}56'$ West by said Ledgewood Manor Associates land ten and thirty-two hundredths (10.32) feet to a corner at other land now or formerly of MGR Realty; thence turning and running South $81^{\circ}43'$ West sixty-seven and fifty-six hundredths (67.56) feet; South $59^{\circ}00'$ West ten and eighty-eight hundredths (10.88) feet and South $66^{\circ}12'$ West one hundred seventy-eight and ten hundredths (178.10) feet to a point; thence continuing on the arc of a curve to the left having a radius of 50 feet an arc distance of fifty-two and fifty-nine hundredths (52.59) feet to a point in the easterly sideline of Lafayette Road, said previous four courses being along land now or formerly of MGR Realty; thence turning and running North $05^{\circ}56'$ East one and sixty-nine hundredths (1.69) feet and North $05^{\circ}31'$ West ninety-six and two tenths (96.2) feet by the Easterly sideline of Lafayette Road to the point of beginning.

The said easement rights are preserved and more fully described in a certain Partial Termination of Easement granted by RPL Properties, LLC to DiLorenzo Lafayette Ledgewood Real Estate, LLC, dated November 3, 2015 and recorded in the Rockingham County Registry of Deeds as of the date hereof, and as set forth therein consist of the rights of RPL Properties, LLC, its successors and assigns ("RPL") to install, lay, maintain, replace and repair and use utility lines of all types including, without limitation, water mains, gas mains, electric wires (above and below grade) and telephone lines (above and below grade), storm and sanitary sewer drains and catch basins, together with all facilities related to the use, operations and maintenance of such utility lines, and the right to pass and re-pass over said premises for the foregoing purposes. Any such work performed by RPL shall be undertaken so as to minimize disruption, disturbance or damage to the premises herein conveyed, and once commenced, such work shall be diligently

pursued to completion. Any damage or disturbance to the premises herein conveyed shall be repaired or restored in a prompt and workmanlike manner as nearly as practicable to the condition that existed immediately prior to such damage or destruction.

Meaning and intending to convey Lot #1, as shown on plan entitled "Subdivision of Land, Portsmouth, N.H., for Genimatas and Robbins" dated November 1978, Revised June 7, 1979, being Durgin Plan #5558, File #689, drawn by John W. Durgin Civil Engineers, which Plan is recorded in the Rockingham County Registry of Deeds as Plan D-8806. See also Warranty Deed of DiLorenzo Lafayette Ledgewood Real Estate, LLC to Grantor dated November 9, 2015 and recorded in the Rockingham County Registry of Deeds at Book 5669, Page 667.

Meaning and intending to describe and convey the same premises conveyed to the Grantor by deed of OMJ Realty dated October 20, 2022 and recorded in the Rockingham County Registry of Deeds at Book 6448, Page 1309 on October 25, 2022.

Transfer Tax: This transfer is exempt from transfer tax pursuant to RSA 78-B:2, XXII.

Homestead: This is not homestead property.

March 30, 2023

John Galt, LLC

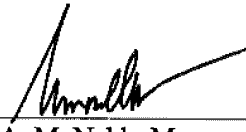
By: 
Mark A. McNabb, Manager

STATE OF NEW HAMPSHIRE
COUNTY OF ROCKINGHAM

The foregoing instrument was acknowledged before me this 30 day of March, 2023 by Mark A. McNabb, Manager of John Galt, LLC a New Hampshire limited liability company, on behalf of the company.

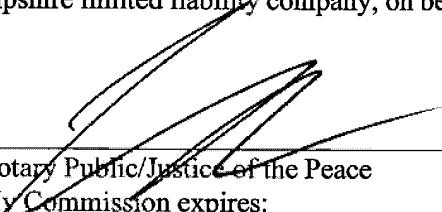
Notary Public/Justice of the Peace
My Commission expires:



ABUTTERS ON WEST SIDE OF LAFAYETTE ROAD

243
1
N/F J.E. SHOLDAR, T.F. GERGEN JR., N.J. CZ/KE, R.E. GERGEN & J.M. GERGEN
155 GREENLEAF AVENUE
PORTSMOUTH, N.H. 03801
5495/1585

243
2A
N/F CROSS ROADS HOUSE, INC.
600 LAFAYETTE ROAD
PORTSMOUTH, N.H. 03801
2773/2910

243
2B
N/F OPERATION BLESSING, INC.
P.O. BOX 4069
PORTSMOUTH, N.H. 03802
3767/1721

AMBIT ENGINEERING, INC.
Civil Engineers & Land Surveyors
200 Griffin Road, Unit 3
Portsmouth, N.H. 03801-7114
Tel (603) 430-9202
Fax (603) 436-2315

- NOTES:**
- 1) PARCEL IS SHOWN ON THE CITY OF PORTSMOUTH ASSESSOR'S MAP 229 AS LOT 8B.
 - 2) OWNERS OF RECORD:
DMJ REALTY, LLC
63 MAIN STREET
PO BOX 1195
SALEM, N.H. 03079
5669/0667
 - 3) THE PARCEL IS NOT IN A FLOOD HAZARD ZONE AS SHOWN ON FIRM PANEL 33015C0270E, EFFECTIVE MAY 17, 2005
 - 4) EXISTING LOT AREA:
98,124 S.F.
2,2526 AC
 - 5) PARCEL IS LOCATED IN THE GATEWAY (GW) DISTRICT.
 - 6) DIMENSIONAL REQUIREMENTS:
MIN. LOT AREA: 43,560 S.F.
FRONTAGE: 200 FT.
DEPTH: 100 FT.
SETBACKS: FRONT: 30 FT.
SIDE: 30 FT.
REAR: 50 FT.
MAXIMUM STRUCTURE HEIGHT: 40 FT.
MAXIMUM ROOF APPURTENANCE HEIGHT: 10 FT.
MAXIMUM BUILDING COVERAGE: 30%
MINIMUM OPEN SPACE: 20%
 - 7) THE PURPOSE OF THIS PLAN IS TO SHOW THE EXISTING CONDITIONS ON TAX MAP 229 LOT 8B.
 - 8) EASEMENTS & RESTRICTIONS:
A) ROAD/UTILITY EASEMENT AREA: SEE C-3316 AND RCRD 2110/428 AND 2184/184. THIS EASEMENT WAS PARTIALLY TERMINATED ON 11/9/15: SEE RCRD 5689/0645.
B) 30' RIGHT OF WAY: SEE D-8806 AND 5446/2589.
C) MUTUAL PARKING AND ACCESS RIGHTS FOR LOTS 1-3 ON PLAN D-8806 ARE OF RECORD, RCRD 2343/128 AND 5446/2588.

POW
PUMT

**SITE REDEVELOPMENT
TUSCAN KITCHEN
581 LAFAYETTE ROAD
PORTSMOUTH, N.H.**

3	REVISED NOTES 2 AND 8	12/21/15
2	ADDED HANDICAP PARKING	8/26/15
1	ADDED EXISTING FORCE MAIN	7/30/15
0	ISSUED FOR COMMENT	7/20/15
NO.	DESCRIPTION	DATE



SCALE: 1" = 30' JULY 2015

EXISTING CONDITIONS PLAN **C1**

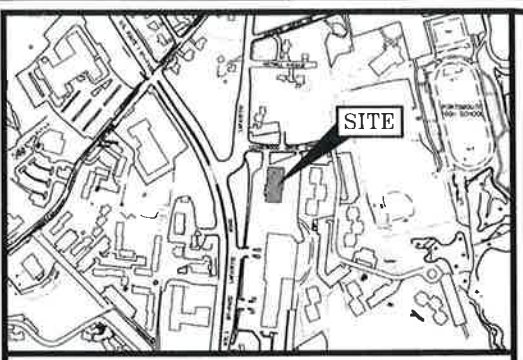

LOCATION MAP SCALE: 1" = 400'±

LEGEND:

- | EXISTING | PROPOSED | |
|----------|----------|------------------------------|
| FM | FM | FORCE MAIN |
| S | S | SEWER LINE |
| G | G | GAS LINE |
| D | D | STORM DRAIN |
| SPP | SPP | SMOOTH PLASTIC PIPE |
| W | W | WATER LINE |
| UE | UE | UNDERGROUND ELECTRIC |
| UU | UU | UNDERGROUND UTILITIES |
| 100 | 100 | OVERHEAD ELECTRIC WIRES |
| 97x3 | 98x0 | CONTOUR |
| | | SPOT ELEVATION |
| | | EDGE OF PAVEMENT (EP) |
| | | WOODS / TREE LINE |
| | | UTILITY POLE |
| | | WATER SHUT OFF/CURB STOP |
| | | GAS SHUT OFF |
| | | GATE VALVE |
| | | HYDRANT |
| | | METER (GAS, WATER, ELECTRIC) |
| | | CATCH BASIN |
| | | TELEPHONE MANHOLE |
| | | SEWER MANHOLE |
| | | DRAIN MANHOLE |
| | | WELL |
| | | EDGE OF WETLAND FLAGGING |
| | | SWAMP/ MARSH |
| | | ASBESTOS CEMENT PIPE |
| | | CAST IRON PIPE |
| | | CORRUGATED METAL PIPE |
| | | CONCRETE MASONRY UNIT |
| | | DUCTILE IRON PIPE |
| | | POLYVINYL CHLORIDE PIPE |
| | | REINFORCED CONCRETE PIPE |
| | | VITRIFIED CLAY PIPE |
| | | ELEVATION |
| | | EDGE OF PAVEMENT |
| | | FINISHED FLOOR |
| | | INVERT |
| | | TEMPORARY BENCH MARK |
| | | TYPICAL |
| | | VERTICAL/SLOPED GRANITE CURB |
| | | CAPE COD BERM |
| | | CENTERLINE |
| | | IRON ROD/CAP FOUND |
| | | NHDOT BOUND FOUND |
| | | POLE/ LIGHT |

LENGTH TABLE

LINE	BEARING	DISTANCE
L1	S15°17'27"W	14.20'
L2	S48°43'16"E	33.26'

EASEMENT LENGTH TABLE

LINE	BEARING	DISTANCE
L3	N05°54'49"E	1.69'
L4	S05°56'03"W	10.32'
L5	S58°58'49"W	10.88'

EASEMENT CURVE TABLE

CURVE	RADIUS	ARC LENGTH	CHORD LENGTH	CHORD BEARING	DELTA ANGLE
C1	50.00'	52.60'	50.20'	S36°02'43"W	60°16'11"

LAFAYETTE
U.S. ROUTE 1

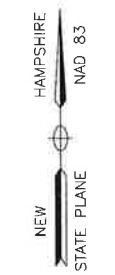
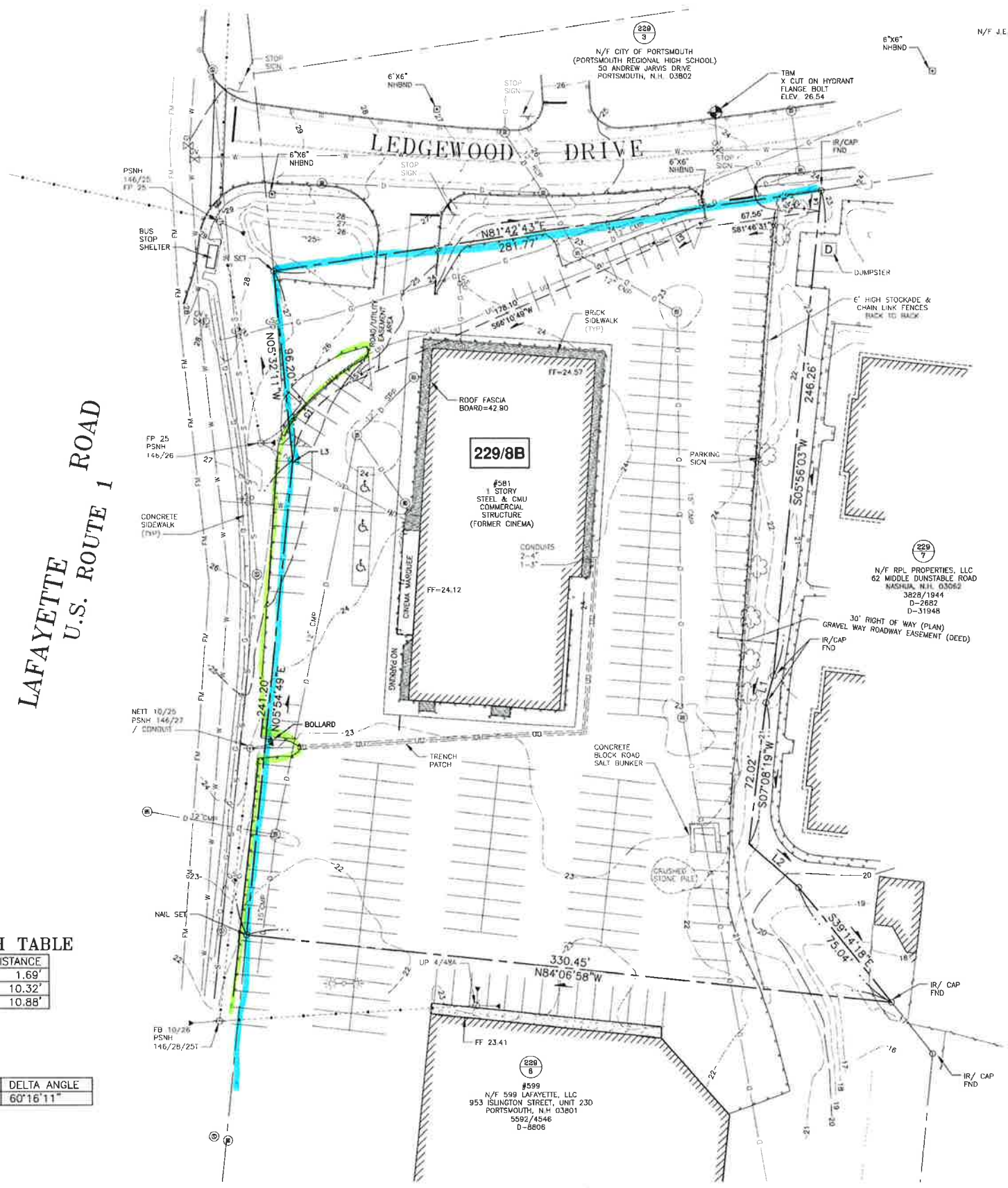

APPROVED BY THE PORTSMOUTH PLANNING BOARD

CHAIRMAN _____ DATE _____

MEMORANDUM OF AGREEMENT

THIS AGREEMENT (“Agreement”) is entered into this ____ day of, 2024, between the **Atlas Commons, LLC**, a New Hampshire limited liability company, with an address of 3 Pleasant Street, Suite 400, Portsmouth, NH 03801 (the “Developer”) and the **City of Portsmouth [School Board?]**, a New Hampshire municipality, with an address of 1 Junkins Avenue, Portsmouth, NH 03801 (the “City”). The Developer and the City may be collectively referred to herein as the “Parties.”

WITNESSETH:

WHEREAS, the Developer is the owner of certain real property located at 581 Lafayette Road in the City of Portsmouth, located at Tax Map/Lot 229/8B (the “Atlas Property”); and

WHEREAS, the City is the owner of certain adjacent real property located at 50 Andrew Jarvis Drive in the City of Portsmouth, located at Tax Map/Lot 229/3, which property currently serves at Portsmouth High School and which property contains a certain right of way abutting the Atlas Property known as Ledgewood Drive and associated cul-de-sac (the “School Property”); and

WHEREAS, the Developer has obtained certain approvals from the City’s land use boards to construct a 5-story mixed-use building with associated on-site and off-site improvements (see generally City permit number LU-23-189) (the “Developer’s Project”); and

WHEREAS, the Developer is seeking a density incentive bonus pursuant to Section 10.5B73 of the Portsmouth Zoning Ordinance (the “Ordinance”), and, as such, the Parties have entered into this Agreement to satisfy the requirements of Section 10.5B73.20 of the Ordinance and the Parties recognize the public benefit to be derived from creating greater pedestrian connectivity from Ledgewood Drive through and to the School Property; and

WHEREAS, the Parties desire for the Developer, at its sole cost, to design, engineer and construct certain public realm improvements within the School Property (collectively, and as further defined herein, the “Public Realm Improvements”).

NOW, THEREFORE, the Parties agree as follows:

Section I: The Developer’s Obligations.

A. The Public Realm Improvements

The Developer shall, at its sole cost and obligation design, engineer and install the following and other minimal Public Realm Improvements shown on the plan set entitled, “Public Realm Plan,” dated January 4, 2024, as revised, prepared by Haley Ward and attached as Exhibit A within the School Property:

1. Install an 8 foot gravel path with lighting and benches that extends from the existing sidewalk on Ledgewood Drive over and across the School Property.

2. Install public benches, a bike rack, a picnic table, basketball court markings, and other minor infrastructure within the School Property.

3. All Public Realm Improvements made by the Developer on the School Property shall be compliant with the Americans with Disabilities Act (ADA),.

4. All changes to the Public Realm Improvements from what is depicted in Exhibit A shall be submitted to the City Manager in writing and reviewed and approved by the Director of Public Works.

B. Construction Obligations

The Developer shall complete at its sole cost and obligation the following tasks to secure the construction of the infrastructure described in Section I, A:

1. Prior to commencing any construction, the Developer shall submit construction plans to the City (the “Construction Plans”). The construction plans must be reviewed and approved by the Director of Public Works for consistency with City standards. The City may, at its sole discretion and cost, employ a third-party engineer to conduct a peer review of the construction plans.

2. The Developer shall secure the construction of the items above via a security instrument, such as a bond or letter of credit, in a form acceptable to the City Attorney. The value of the security instrument shall be estimated by the Developer and set by the Director of Public Works.

3. The Developer shall enter into a Construction Management Mitigation Agreement (CMMP) with the City sufficient to describe the Developer’s construction plan for the Public Realm Improvements and the Developer’s Project.

4. As a part of the CMMP, the Developer shall designate a Project Manager, who shall serve as the point of contact for all public inquiries regarding the Public Realm Improvements, the Developer’s Project, and the related impacts on vehicular travel. This point of contact shall be available to respond to public inquiries and respond to requests within 24 hours.

5. The Developer shall provide the City with proof of insurance at the City’s customary levels for the period of construction of the Public Realm Improvements. The proof of insurance shall list the City as an additional insured.

Section II: The City’s Obligations

1. The City shall employ a third-party engineer to oversee the construction of the Public Realm Improvements. The cost of the third-party engineer shall be paid by the City.

2. The City hereby waives all fees applicable to the construction of the Public Realm Improvements. This provision shall not apply to any permit fees required pursuant to the Developer's Project.

3. The City shall designate a Project Manager for the Public Realm Improvements. All communications regarding the Public Realm Improvements from the Developer shall be addressed to the Project Manager, with a copy to the City Attorney.

4. Following approval of the Public Realm Improvements by the City's third-party engineer and the Director of Public Works, the City shall accept ownership in writing of all Public Realm Improvements. If review by the City's third-party engineer or the City's Public Works Department reveal the Public Realm Improvements are not constructed to City standards or the Construction Plans, the Developer shall cause the insufficiencies to be remedied to the City's satisfaction.

Section III: Miscellaneous

1. Compliance with other laws: The Developer acknowledges that their obligations under this contract are subject to full compliance with all applicable state, federal, and local laws, and failure to adhere to such laws shall constitute a material breach of this contract.

2. Costs: Following acceptance of the Public Realm Improvements by the City, the City shall assume maintenance of the Public Realm Improvements. The City's maintenance obligations shall not exceed the ordinary maintenance responsibilities for any property in the City.

3. Entire Agreement. This Agreement and the attachments hereto, each of which is hereby incorporated herein, sets forth all the agreements, promises, covenants conditions and undertakings between the parties with respect to the subject matter hereof, and supersedes all prior and contemporaneous agreements and understandings, inducements, or conditions, express or implied, oral or written.

4. Amendment. No waiver or modification of any of the terms of this Agreement shall be valid unless in writing and signed by each of the parties hereto. Failure by any party to enforce any rights under this Agreement shall not be construed as a waiver of such rights, and a waiver by any party of a default hereunder in one or more instances shall not be construed as constituting a continuing waiver or as a waiver of other instances of default.

5. Waiver of Breach: The failure of either party to enforce any provision of this contract shall not be construed as a waiver of subsequent breaches or as a relinquishment of the right to enforce such provisions. No waiver by either party of any breach of this contract shall be deemed to be a waiver of any other or subsequent breach.

6. Governing Law. The construction and effect of the terms of this Agreement shall be determined in accordance with the laws of the State of New Hampshire.

As authorized by vote of the Portsmouth City Council taken on _____, during its meeting that commenced _____.

Atlas Commons, LLC

By: _____
Mark. A. McNabb
Its Manager

STATE OF NEW HAMPSHIRE
COUNTY OF ROCKINGHAM

On this ____ day of _____, 2024, before: me, the undersigned notary public, personally appeared Mark A. McNabb, Manager of Atlas Commons, LLC, proved to me through satisfactory evidence of identification, which was a valid driver's license, to be the person whose name is signed on the preceding or attached document, and acknowledged to me that he signed it in his capacity as stated therein and voluntarily for its stated purpose.

Notary Public
My Commission expires:

City of Portsmouth, New Hampshire

By: _____
Karen S. Conard, City Manager

STATE OF NEW HAMPSHIRE
COUNTY OF ROCKINGHAM

On this ____ day of _____, 2024, before: me, the undersigned notary public, personally appeared Karen S. Conard, City Manager of the City of Portsmouth New Hampshire, proved to me through satisfactory evidence of identification, which was a valid driver's license, to be the person whose name is signed on the preceding or attached document, and acknowledged to me that she signed it in her capacity as stated therein and voluntarily for its stated purpose.

Notary Public:
My Commission Expires:

581 Lafayette Road						
Unit/Parking Analysis						
February 22, 2024						
Level	Room No.	# bedrooms	Area (sf)	spaces/unit	Workforce	Accessible
LEVEL 5	B504	STUDIO	369	0.50		
LEVEL 5	A505	STUDIO	424	0.50		
LEVEL 5	A507	STUDIO	424	0.50		
LEVEL 5	A503	STUDIO	425	0.50		
LEVEL 5	A504	STUDIO	425	0.50		
LEVEL 5	A509	STUDIO	425	0.50		
LEVEL 4	B406	STUDIO	425	0.50		
LEVEL 3	B306	STUDIO	426	0.50		
LEVEL 5	B503	STUDIO	434	0.50		
LEVEL 5	A511	STUDIO	457	0.50		
LEVEL 4	B411	STUDIO- ACCESSIBLE	494	0.50	Fully Accessible-1	
LEVEL 5	A508	STUDIO	499	0.50		
LEVEL 3	B303	1BR	499	0.50		
LEVEL 3	B311	1BR	499	0.50		
LEVEL 4	B403	1BR	499	0.50		
LEVEL 3	B304	1BR	524	1.00		
LEVEL 4	B404	1BR	531	1.00		
LEVEL 5	B505	1BR	532	1.00		
LEVEL 5	B506	1BR	532	1.00		
LEVEL 5	B502	1BR	541	1.00		
LEVEL 2	B207	1BR	542	1.00		
LEVEL 3	B309	1BR	572	1.00		
LEVEL 4	B409	1BR	572	1.00		
LEVEL 4	A407	STUDIO- ACCESSIBLE	580	1.00	Fully Accessible-2	
LEVEL 4	B410	1BR	599	1.00		
LEVEL 4	A408	1BR	620	1.00		
LEVEL 3	B310	1BR	621	1.00		
LEVEL 3	B307	1BR- ACCESSIBLE	644	1.00	Fully Accessible-3	
LEVEL 4	B408	1BR	645	1.00		
LEVEL 2	B206	1BR	651	1.00		
LEVEL 3	B308	1BR	652	1.00		
LEVEL 4	B407	1BR	659	1.00		
LEVEL 2	A205	1BR	660	1.00		
LEVEL 3	A305	1BR	660	1.00		
LEVEL 4	B401	1BR	667	1.00		
LEVEL 5	A502	1BR	672	1.00		
LEVEL 3	A309	1BR	682	1.00		
LEVEL 3	A307	1BR	694	1.00		
LEVEL 2	A207	1BR	698	1.00		
LEVEL 3	A308	1BR	699	1.00		
LEVEL 4	A405	1BR	702	1.00		
LEVEL 3	B301	1BR	703	1.00		
LEVEL 4	B402	2BR	708	1.00		
LEVEL 2	A209	1BR	709	1.00		
LEVEL 2	A208	1BR	723	1.00		
LEVEL 5	B507	2BR- ACCESSIBLE	733	1.00	Fully Accessible-4	
LEVEL 4	A406	1BR	749	1.00		
LEVEL 3	B305	2BR	749	1.00		
LEVEL 4	B405	2BR	749	1.00		
LEVEL 3	B302	2BR	780	1.30		
LEVEL 2	B202	2BR	782	1.30		
LEVEL 2	A206	1BR	786	1.30		
LEVEL 3	A306	1BR	823	1.30		
LEVEL 2	B201	2BR-WORKFORCE	872	1.30		
LEVEL 2	A203	1BR- ACCESSIBLE- WF	886	1.30	Workforce 1	Fully Accessible-5
LEVEL 5	A506	1BR- ACCESSIBLE- WF	910	1.30	Workforce 2	Fully Accessible-6
LEVEL 3	A303	2BR- WF	988	1.30	Workforce 3	
LEVEL 5	B501	2BR-WORKFORCE	1007	1.30	Workforce 4	
LEVEL 2	B203	3BR-WORKFORCE	1146	1.30	Workforce 5	
LEVEL 4	A402	3BR-WORKFORCE	1365	1.30	Workforce 6	
LEVEL 2	B204	3BR- WF	1456	1.30	Workforce 7	
LEVEL 2	B205	3BR-WORKFORCE- ACCESSIBL	1497	1.30	Workforce 8	Fully Accessible-7
LEVEL 3	A302	3BR-WORKFORCE	1504	1.30	Workforce 9	
LEVEL 2	A202	3BR-WORKFORCE	1535	1.30	Workforce 10	
LEVEL 5	A510	3BR- WF	1535	1.30	Workforce 11	
LEVEL 4	A403	3BR- WF	1726	1.30	Workforce 12	
LEVEL 4	A401	3BR-WORKFORCE	2034	1.30	Workforce 13	
LEVEL 3	A301	3BR-WORKFORCE	2056	1.30	Workforce 14	
LEVEL 2	A204	3BR	2144	1.30	Workforce 15	
LEVEL 4	A404	3BR	2153	1.30		
LEVEL 3	A304	3BR-ACCESSIBLE	2172	1.30		Fully Accessible-8
LEVEL 2	A201	3BR	2200	1.30		
Total Units			Parking Req.	workforce housing		
Total Units:	72		71.40	20% of units	average unit size	
Visitor Parking - 1 space per every 5 dwellings			14.40		14.4	848
Residential automobile parking required (base, unadjusted)			85.80		86.00	ROUNDED UP

Car Parking Spaces Required per Unit Size			
0-500	0.5		
500-750	1.0		
751-1900	1.3		

Bicycle Parking Required		
use	spaces required per use	total required
multifamily	1 bicycle for every 5 dwelling units	15
restaurant/rec	1 bicycle for each 10 car parking spaces	12
TOTAL Required		27
Total Provided (in building, basement + 1st floor)		80
Total Provided (outside)		8
Total Provided, inside & outside		88
Excess Provided (beyond required)		61
Excess applied to New Additions (housing)	(18.0)	(3)
Excess applied to existing building	(36.0)	(6)
Net leftover excess bicycle parking	7	(9)
Scooter parking provided (none required)		7
Motorcycle parking provided (none required)		2

Apartment Types - Unit Mix & Locations					
level	number of bedrooms per apartment				
	5	1	2	3	Total
5	9	5	2	1	17
4	3	10	2	4	19
3	1	13	3	3	20
2	0	8	2	6	16
total	13	36	9	14	72
Total bedrooms	13	36	18	42	109

Apartment Types - Unit Distribution per Building				
Level	Building A	Building B	TOTAL	
5	10	7	17	
4	8	11	19	
3	9	11	20	
2	9	7	16	
total units	36	36	72	

				with gateway deduct -20%
Apartments Parking Required				
subtotal base parking spaces required				86.00
Gateway deduct -20%				(17.20)
Subtotal parking required				68.80
	# excess bike spaces	%	# car spaces deducted	
Bicycle parking deduction 1 space for 6 bikes, max 5%:				65.80
	(18.0)	3.50%	(3.0)	
max 5% allowed = 3.44 spaces				
Apartment Parking Required (adjusted for Gateway-1 & bikes)				66.00
				Rounded Up

					subtotal w/20% gateway deduct
Restaurant/Recreation Parking Required					
	spaces/gfa	gfa or occ	spaces (rounded up)		
restaurant	1/100	13,982.00	140		112
mezzanine office	1/350	1,060.00	4		4
recreation (golf)	1per 4 occ.	20.00	5		4
subtotal					149
Gateway deduct -20%					-29.8
Subtotal restaurant/recreation parking required					120
	# excess bike spaces	%	# car spaces	round down	
Bicycle parking deduction - 1 space for 6 bikes, max 5%					
	42.0	-5.00%	(6.0)	(6.00)	
max 5% allowed = 6.00 spaces					
Restaurant/Recreation Parking Required (adjusted for Gateway-1 & bikes)					114

bicycle deduct 5%		total
	(6.00)	106.0
	0.00	4.0
	0.00	4.0

9. Eating and Drinking Places		
9.10-9.50	All eating and drinking places	1 per 100 sf GFA
10. RECREATION USES		
4.10	Religious, sectarian or private non-profit recreational use	Parking demand analysis
4.20	Cinema or similar indoor amusement use with no live performance	0.4 per seat, or Parking demand analysis
4.30	Indoor recreation use, such as bowling alley or arcade	1 per 4 persons maximum occupancy
4.40	Health club, yoga studio, martial arts school, or similar use	1 per 250 sf GFA
4.50	Outdoor recreation use	Parking demand analysis
4.60	Amusement park, water park or theme park	NA - Prohibited Use

TOTAL parking required all uses (adjusted for gateway & bikes) 180.0

Shared Parking 10.1112.60 Land Use	Weekday				Weekend				Nighttime		Maximum TOTAL Required
	daytime (8am-5pm)	spaces required	evening (6-12pm)	spaces required	daytime (8am-5pm)	spaces required	evening (6-midnight)	spaces required	(midnight-6am)	spaces required	
Apartments	60%	39.6	100%	66.0	80%	52.8	100%	66.0	100%	66.0	
restaurant	70%	74.2	100%	106.0	80%	84.8	100%	106.0	10%	10.6	
Office	100%	4.0	20%	0.8	10%	0.4	5%	0.2	5%	0.2	
entertainment (golf)	40%	1.6	100%	4.0	80%	3.2	100%	4.0	10%	0.4	
ADJUSTED TOTAL Required, all uses, shared		119.4		176.80		141.2		176.2		77.2	177

Total Parking Proposed		
In-building, level 1 + basement		151
Open air, on site		30
Off-site parking per deeded easement		0
Total parking proposed		181
Excess (Defecit)		4
Existing total available-today		154
Proposed Net Increase (reduction) in parking		23

MIXED USE DEVELOPMENT

581 LAFAYETTE ROAD PORTSMOUTH, NEW HAMPSHIRE SITE PERMIT PLANS

OWNER:

ATLAS COMMONS, LLC
3 PLEASANT STREET
SUITE #400
PORTSMOUTH, NH 03801

LAND SURVEYOR & CIVIL ENGINEER:

AMBIT ENGINEERING, INC.
A DIVISION OF HALEY WARD, INC
200 GRIFFIN ROAD, UNIT 3
PORTSMOUTH, N.H. 03801
Tel. (603) 430-9282
Fax (603) 436-2315

ARCHITECT:

ARCOVE ARCHITECTS
3 CONGRESS STREET, SUITE 1
PORTSMOUTH, NH 03801
TEL. (603) 988-0042

LANDSCAPE ARCHITECT:

TERRA FIRMA LANDSCAPE
ARCHITECTURE
163A COURT STREET
PORTSMOUTH, NH 03801
TEL. (603) 430-8388

PERMIT LIST:

NHDES SEWER DISCHARGE PERMIT: TO BE SUBMITTED
PORTSMOUTH SITE PLAN APPROVAL: PENDING
CITY COUNCIL APPROVAL: PENDING

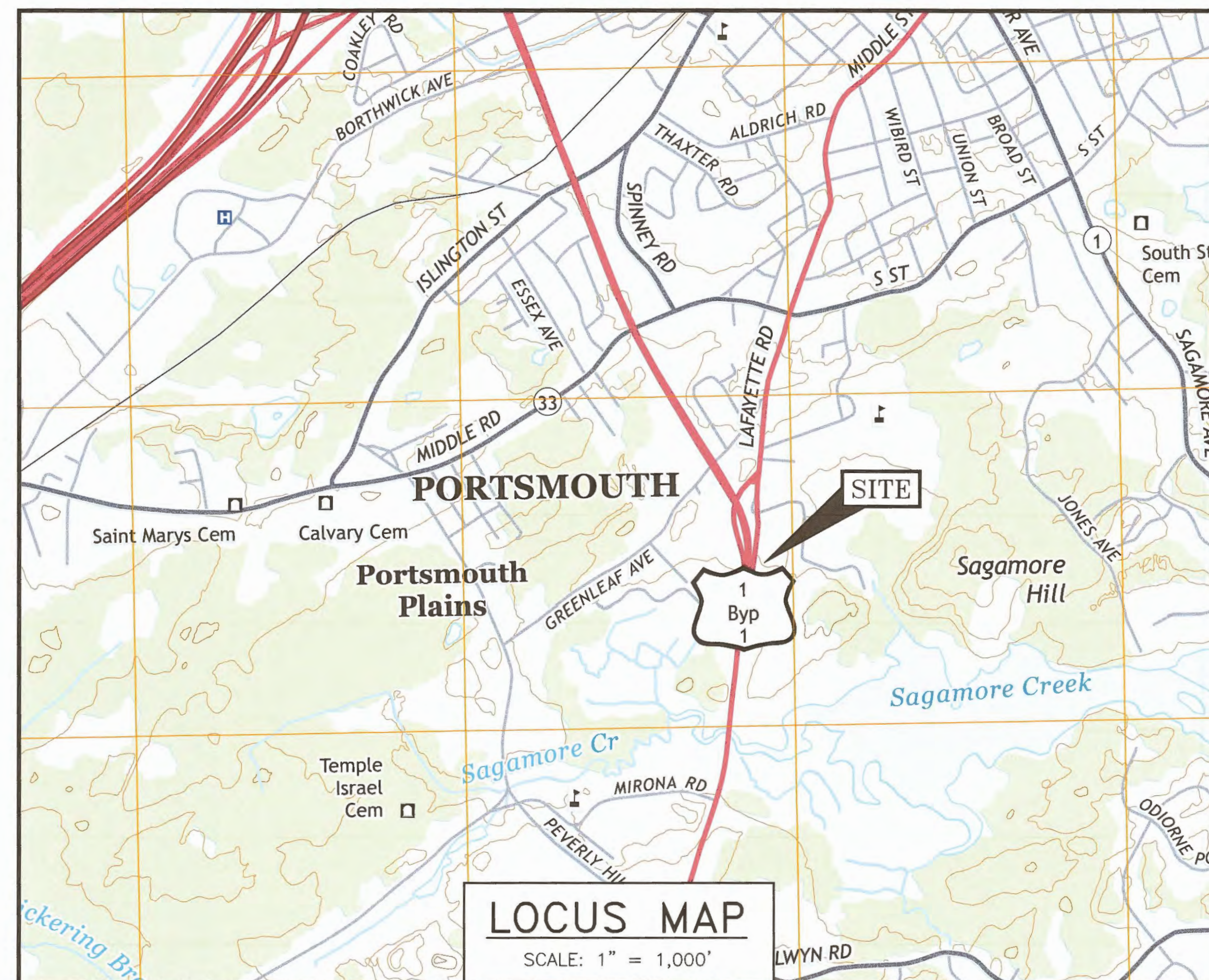
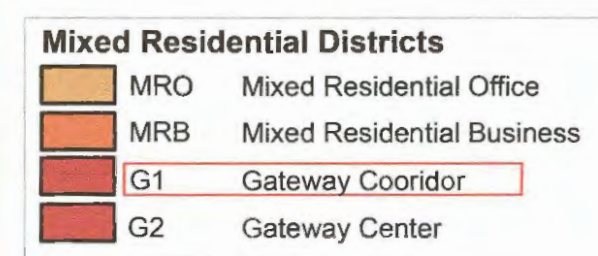
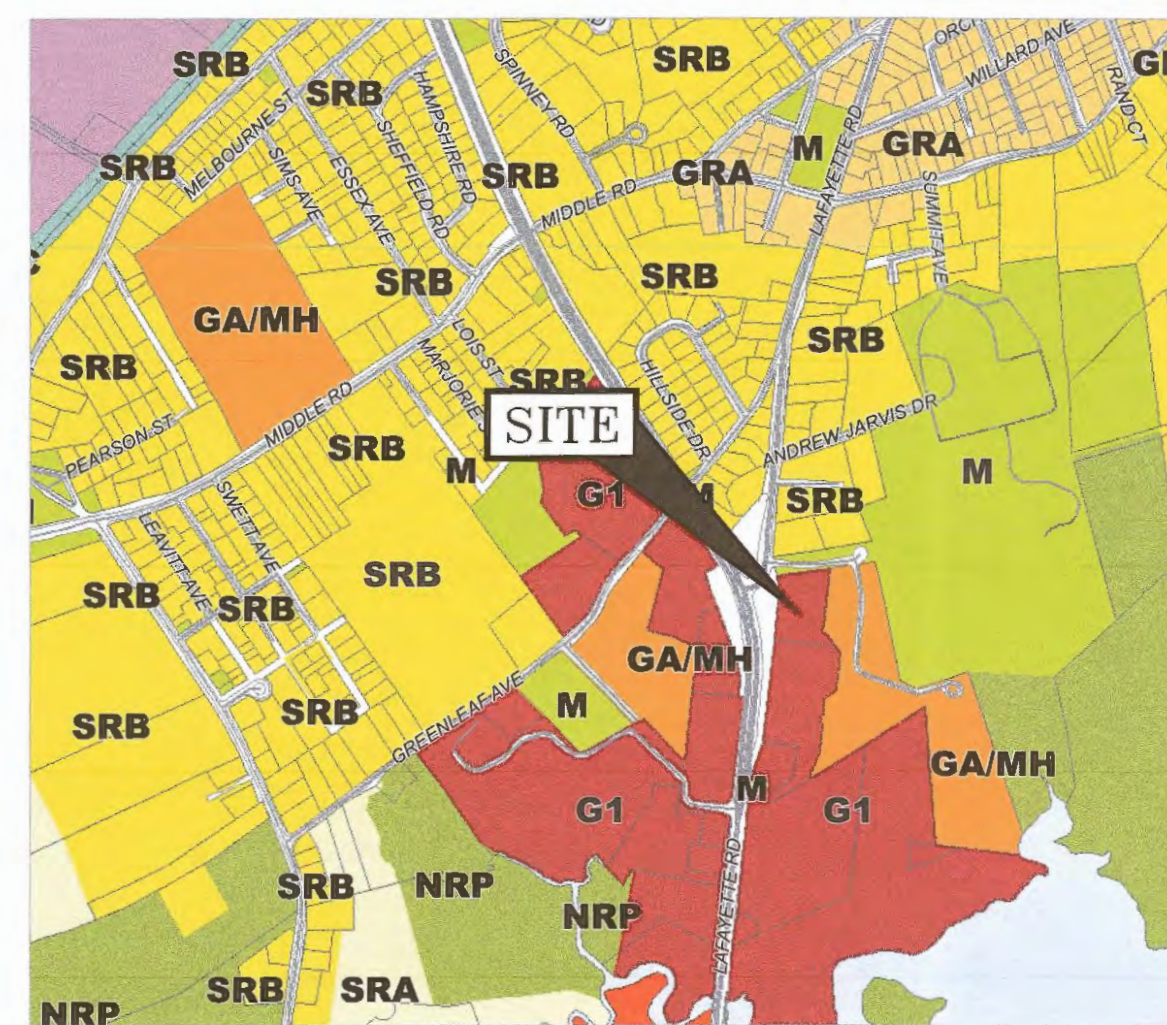

LOCUS MAP
SCALE: 1" = 1,000'

LEGEND:

EXISTING	PROPOSED	
---	---	PROPERTY LINE
---	---	SETBACK
S	S	SEWER PIPE
SL	SL	SEWER LATERAL
G	G	GAS LINE
D	D	STORM DRAIN
W	W	WATER LINE
WS	WS	WATER SERVICE
UGE	UGE	UNDERGROUND ELECTRIC
OHW	OHW	OVERHEAD ELECTRIC/WIRES
---	---	FOUNDATION DRAIN
---	---	EDGE OF PAVEMENT (EP)
100	100	CONTOUR
97x3	98x0	SPOT ELEVATION
○	○	UTILITY POLE
☀	☀	WALL MOUNTED EXTERIOR LIGHTS
☒	☒	TRANSFORMER ON CONCRETE PAD
⊕	⊕	ELECTRIC HANDHOLD
⊖	⊖	SHUT OFFS (WATER/GAS)
⊗	⊗	GATE VALVE
⊙	⊙	HYDRANT
⊚	⊚	CATCH BASIN
⊛	⊛	SEWER MANHOLE
⊜	⊜	DRAIN MANHOLE
⊝	⊝	TELEPHONE MANHOLE
⊞	⊞	PARKING SPACE COUNT
⊟	⊟	PARKING METER
LSA	LSA	LANDSCAPED AREA
TBD	TBD	TO BE DETERMINED
CI	CI	CAST IRON PIPE
COP	COP	COPPER PIPE
DI	DI	DUCTILE IRON PIPE
PVC	PVC	POLYVINYL CHLORIDE PIPE
RCP	RCP	REINFORCED CONCRETE PIPE
AC	AC	ASBESTOS CEMENT PIPE
VC	VC	VITRIFIED CLAY PIPE
EP	EP	EDGE OF PAVEMENT
EL	EL	ELEVATION
FF	FF	FINISHED FLOOR
INV	INV	INVERT
S =	S =	SLOPE FT/FT
TBM	TBM	TEMPORARY BENCH MARK
TYP	TYP	TYPICAL



INDEX OF SHEETS

DWG No.	Description
-	COMMUNITY SPACE EASEMENT PLAN
C1	EXISTING CONDITIONS PLAN
C2	DEMOLITION PLAN
C3	SITE PLAN
L1A, L1B, L2	LANDSCAPE PLANS - ON SITE & OFF SITE
L3	LIGHTING PLAN
C4	PARKING PLAN
C5	UTILITY PLAN
C6	GRADING, DRAINAGE, EROSION CONTROL PLAN
C7	OPEN SPACE PLAN
C8	ON-SITE COMMUNITY SPACE PLAN
C8.1	OFF-SITE LANDSCAPE MAINTENANCE AREA
C9	PUBLIC REALM PLAN
C10	PUBLIC REALM PLAN
C11	EXISTING AVERAGE GRADE PLANE
C12	PROPOSED AVERAGE GRADE PLANE
T1 & T2	TURNING PLANS
D1 - D6	EROSION CONTROL NOTES AND DETAILS
PB1.00-1.06	FLOOR PLANS
PB2.00-2.01	ELEVATIONS
PB3.01	RENDERINGS

UTILITY CONTACTS

ELECTRIC:
EVERSOURCE
1700 LAFAYETTE ROAD
PORTSMOUTH, N.H. 03801
Tel. (603) 436-7708, Ext. 555.5678
ATTN: MICHAEL BUSBY, P.E. (MANAGER)

NATURAL GAS:
UNITIL
325 WEST ROAD
PORTSMOUTH, N.H. 03801
Tel. (603) 294-5144
ATTN: DAVE BEAULIEU

CABLE:
COMCAST
155 COMMERCE WAY
PORTSMOUTH, N.H. 03801
Tel. (603) 679-5695 (X1037)
ATTN: MIKE COLLINS

SEWER & WATER:
PORTSMOUTH DEPARTMENT OF PUBLIC WORKS
680 PEVERLY HILL ROAD
PORTSMOUTH, N.H. 03801
Tel. (603) 427-1530
ATTN: JIM TOW

COMMUNICATIONS:
FAIRPOINT COMMUNICATIONS
JOE CONSIDINE
1575 GREENLAND ROAD
GREENLAND, N.H. 03840
Tel. (603) 427-5525

PORTSMOUTH APPROVAL CONDITIONS NOTE:
ALL CONDITIONS ON THIS PLAN SET SHALL REMAIN IN EFFECT IN PERPETUITY PURSUANT TO THE REQUIREMENTS OF THE CITY OF PORTSMOUTH SITE PLAN REVIEW REGULATIONS.

APPROVED BY THE PORTSMOUTH PLANNING BOARD

CHAIRMAN

DATE

**SITE PLANS
MIXED USE DEVELOPMENT
581 LAFAYETTE ROAD
PORTSMOUTH, N.H.**

AMBIT ENGINEERING, INC.
A DIVISION OF HALEY WARD, INC.

WWW.HALEYWARD.COM

200 Griffin Road, Unit 3
Portsmouth, NH 03801
603.430.9282

PLAN SET SUBMITTAL DATE: 21 FEBRUARY 2024

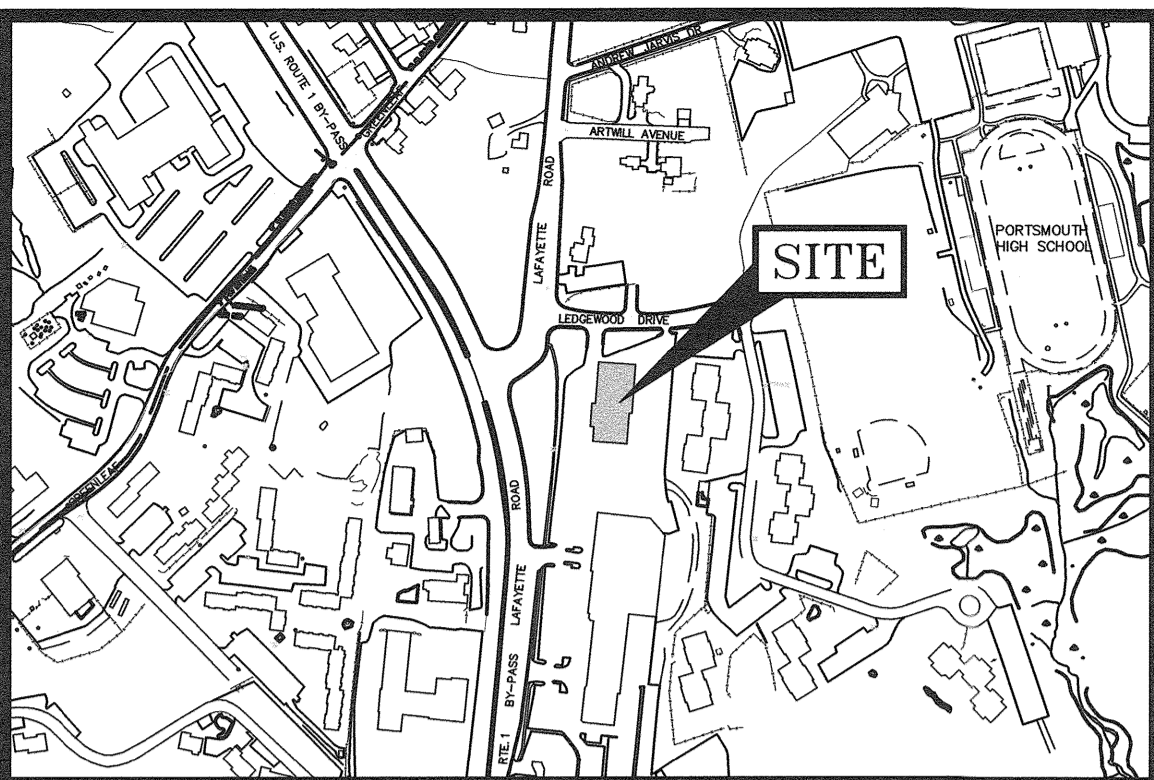

LOCATION MAP SCALE: 1" = 400' ±

LAFAYETTE ROAD
U.S. ROUTE 1

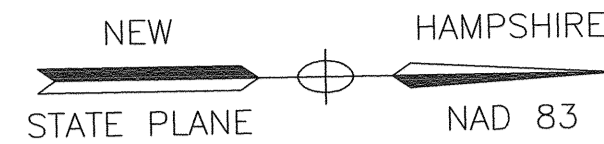

200 Griffin Road, Unit 3
Portsmouth, NH 03801
603.436.2915

WWW.HALEYWARD.COM

NOTES:

- 1) PARCEL IS SHOWN ON THE CITY OF PORTSMOUTH ASSESSOR'S MAP 229 AS LOT 8B.
- 2) OWNERS OF RECORD:
ATLAS COMMONS, LLC
3 PLEASANT STREET, SUITE 400
PORTSMOUTH, NH 03801
6474/1538
- 3) THE PARCEL IS NOT IN A FLOOD HAZARD ZONE AS SHOWN ON FIRM PANEL 33015C0270F, EFFECTIVE JANUARY 29, 2021
- 4) EXISTING LOT AREA:
98,124 S.F.
2.2526 AC
- 5) PARCEL IS LOCATED IN THE GATEWAY NEIGHBORHOOD CORRIDOR (G1) DISTRICT.
- 6) DIMENSIONAL REQUIREMENTS:
SEE ZONING ORDINANCE SECTION 10.5B22.10
- 7) THE PURPOSE OF THIS PLAN IS TO SHOW THE COMMUNITY SPACE EASEMENT ON TAX MAP 229 LOT 8B AND THE ADDITIONAL OFF-SITE AREA WHERE CITY LANDSCAPE MAINTENANCE WILL BE THE RESPONSIBILITY OF THE TAX MAP 229 LOT 8B PROPERTY OWNER.

LENGTH TABLE

LINE	BEARING	DISTANCE
L1	S15°17'27"W	14.20'
L2	S48°43'16"E	33.26'

COMMUNITY SPACE

- 6,120 S.F. OF POCKET PARK
- 1,294 S.F. OF OUTDOOR DINING CAFE
- PROPOSED COMMUNITY SPACE 7,414 S.F.
- LOT AREA 98,124 S.F.
- COMMUNITY SPACE REQUIRED: 10%
(PER SECTION 10.5B41.80.2)
- COMMUNITY SPACE PROVIDED: 7.6%
- COMMUNITY SPACE USES
(PER SECTION 10.5B102)
- PROPOSED USES: OUTDOOR DINING CAFE
POCKET PARK
- MAINTENANCE AREA
9,351 S.F. OF AREA WHERE THE LANDSCAPING WILL BE MAINTAINED BY THE OWNER OF TAX MAP 229 LOT 8B.

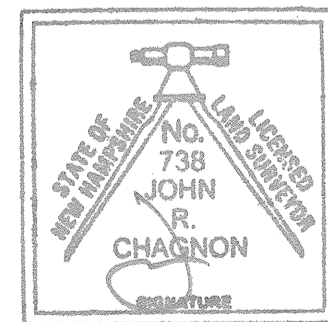
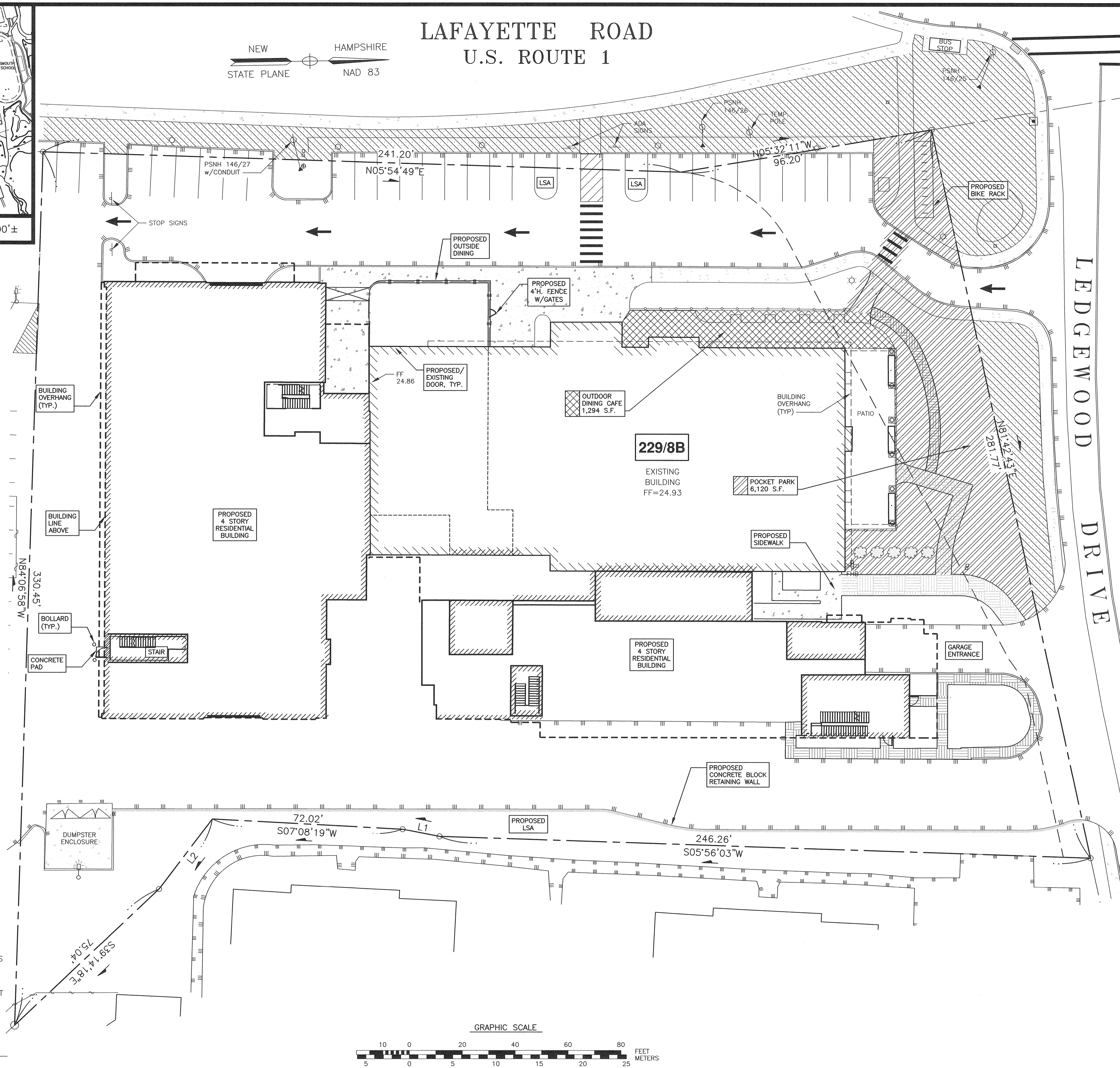

I CERTIFY THAT THIS PLAN WAS PREPARED UNDER MY DIRECT SUPERVISION, THAT IT IS THE RESULT OF A FIELD SURVEY BY THIS OFFICE AND HAS AN ACCURACY OF THE CLOSED TRAVERSE THAT EXCEEDS THE PRECISION OF 1:15,000.

I CERTIFY THAT THIS SURVEY PLAT IS NOT A SUBDIVISION PURSUANT TO THIS TITLE AND THAT THE LINES OF STREETS AND WAYS SHOWN ARE THOSE OF PUBLIC OR PRIVATE STREETS OR WAYS ALREADY ESTABLISHED AND THAT NO NEW WAYS ARE SHOWN.

John R. Chagnon
JOHN R. CHAGNON, LLS-738
DATE: 2.21.24

GRAPHIC SCALE

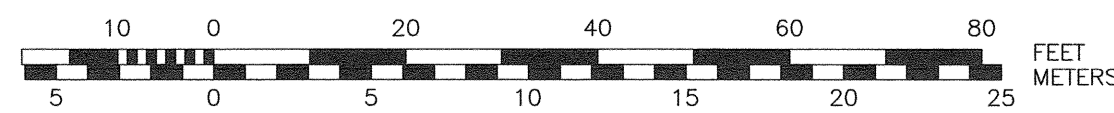

NO.	DESCRIPTION	DATE
1	EASEMENT LOCATIONS	2/21/24
0	ISSUED FOR COMMENT	1/24/24

581 LAFAYETTE ROAD
COMMUNITY SPACE
EASEMENT PLAN
TAX MAP 229 - LOT 8B
TO
THE CITY OF PORTSMOUTH
OWNER
ATLAS COMMONS, LLC
PROPERTY LOCATED AT
581 LAFAYETTE ROAD
CITY OF PORTSMOUTH
COUNTY OF ROCKINGHAM
STATE OF NEW HAMPSHIRE

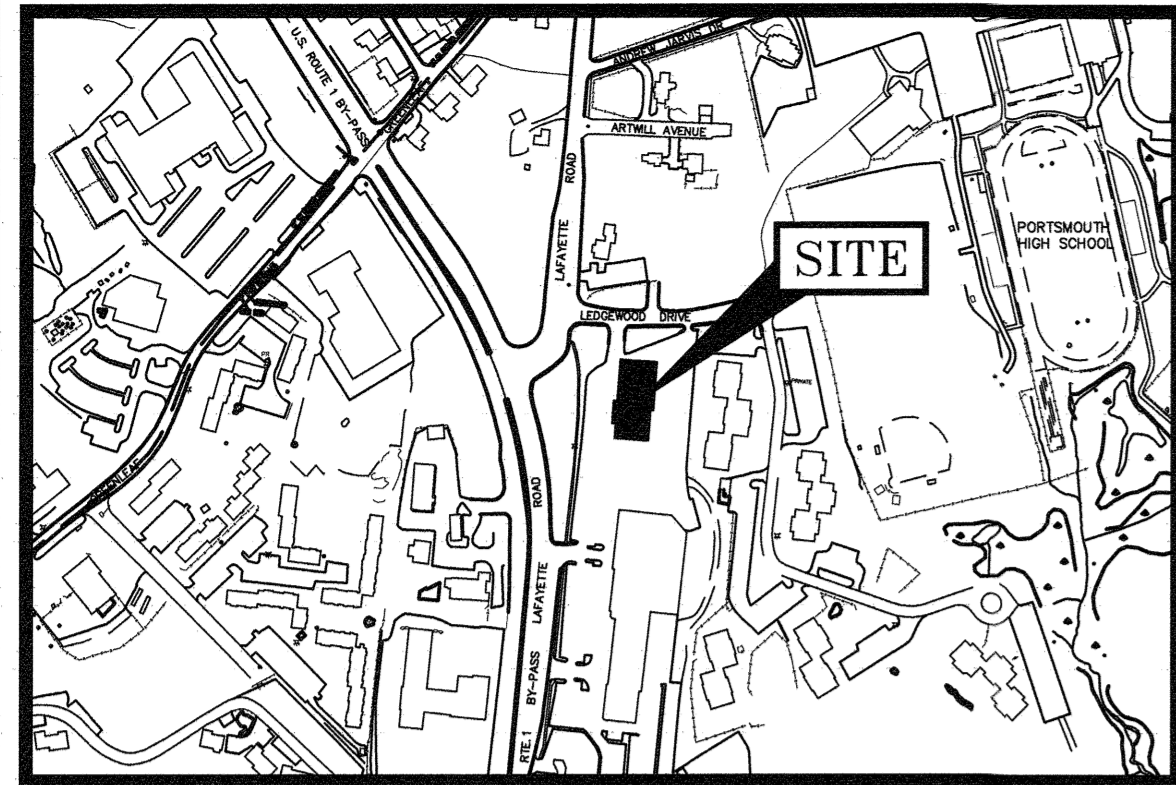

LOCATION MAP

SCALE: 1" = 400'±

LENGTH TABLE

LINE	BEARING	DISTANCE
L1	S15°17'27"W	14.20'
L2	S48°43'16"E	33.26'

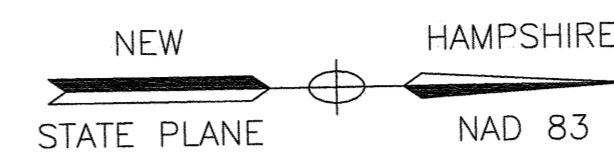

LAFAYETTE ROAD
U.S. ROUTE 1

LEGEND

- EXISTING**
- 124/21 MAP 124 / LOT 21
 - N/F NOW OR FORMERLY
 - RP RECORD OF PROBATE
 - RCRD ROCKINGHAM COUNTY REGISTRY OF DEEDS
 - BOUNDARY LINE
 - SETBACK LINE
 - RR SPK FND RAILROAD SPIKE FOUND
 - IR FND IRON ROD FOUND
 - IP FND IRON PIPE FOUND
 - DH FND DRILL HOLE FOUND
 - BND w/ DH BOUND w/ DRILL HOLE
 - FM FORCE MAIN
 - S SEWER LINE
 - G GAS LINE
 - D STORM DRAIN
 - W POTABLE WATER LINE
 - UNDERGROUND ELECTRIC
 - OVERHEAD WIRES
 - 100 CONTOUR LINE
 - 97x3 SPOT ELEVATION
 - EDGE OF PAVEMENT
 - WOODS / TREE LINE
 - UTILITY POLE (w/ GUY) (w/ LIGHT)
 - LIGHT POLE
 - SHUTOFF/CURB STOP (WATER, GAS, SEWER)
 - GATE VALVE
 - HYD. HYDRANT
 - CB CATCH BASIN
 - TELEPHONE MANHOLE
 - SEWER MANHOLE
 - DRAIN MANHOLE
 - FF FINISHED FLOOR
 - INV. INVERT
 - TBM TEMPORARY BENCHMARK
 - TYP. TYPICAL

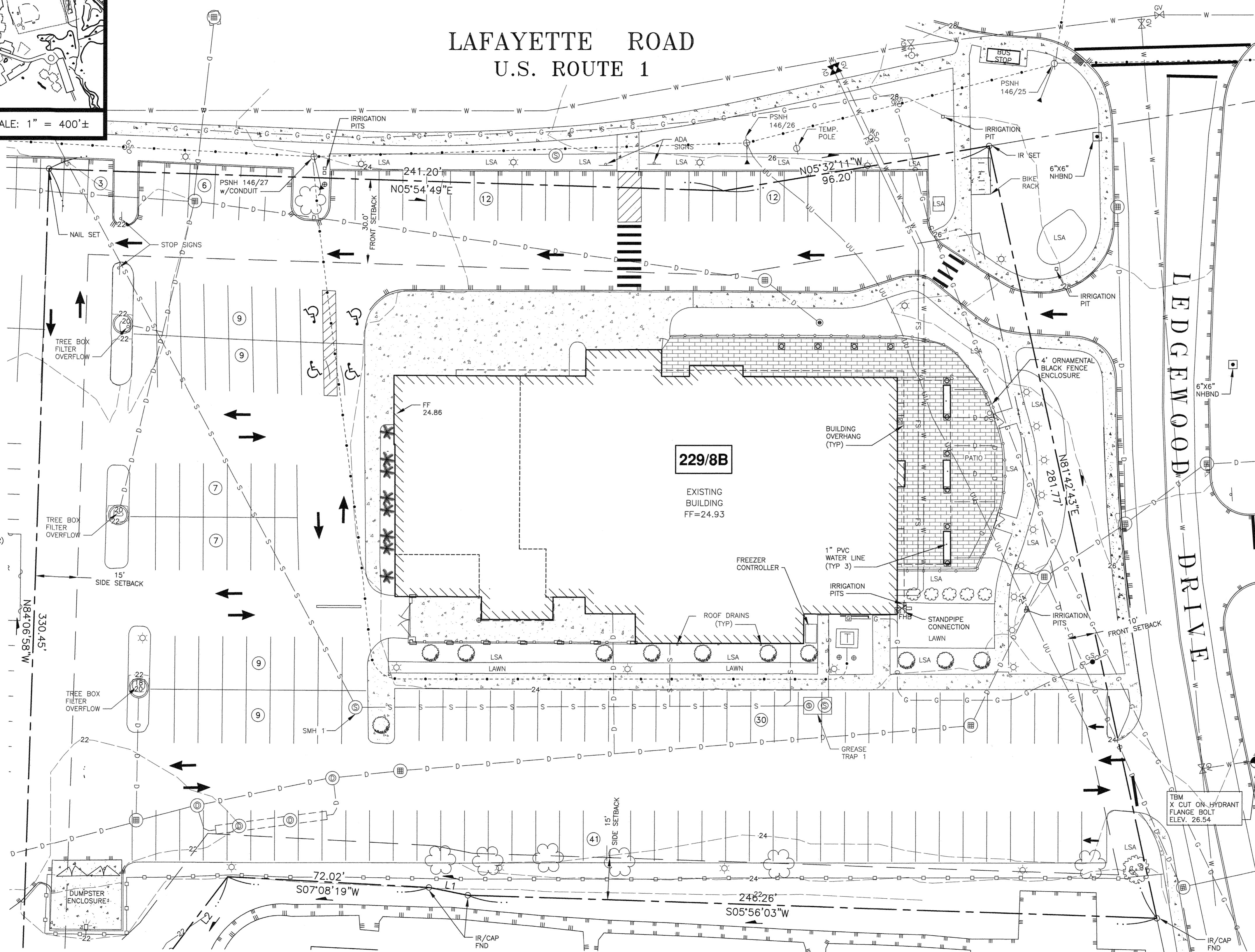

GRAPHIC SCALE

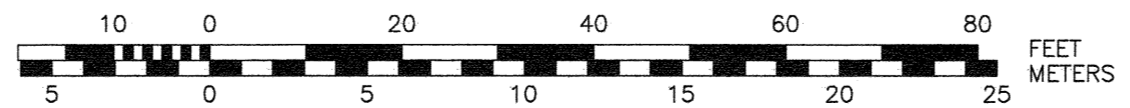

200 Griffin Road, Unit 3
Portsmouth, NH 03801
603.430.9282

WWW.HALEYWARD.COM

NOTES:

- 1) PARCEL IS SHOWN ON THE CITY OF PORTSMOUTH ASSESSOR'S MAP 229 AS LOT 8B.
- 2) OWNERS OF RECORD:
ATLAS COMMONS, LLC
3 PLEASANT STREET, SUITE 400
PORTSMOUTH, NH 03801
6474/1538
- 3) THE PARCEL IS NOT IN A FLOOD HAZARD ZONE AS SHOWN ON FIRM PANEL 33015C0270F, EFFECTIVE JANUARY 29, 2021.
- 4) EXISTING LOT AREA:
98,124 S.F.
2,2526 AC
- 5) PARCEL IS LOCATED IN THE GATEWAY (GW) DISTRICT.
- 6) DIMENSIONAL REQUIREMENTS:
SEE ZONING ORDINANCE SECTION 10.5B22.10
- 7) THE PURPOSE OF THIS PLAN IS TO SHOW THE EXISTING CONDITIONS ON TAX MAP 229 LOT 8B.
- 8) EASEMENTS & RESTRICTIONS:
A) ROAD/UTILITY EASEMENT AREA: SEE C-3316 AND RCRD 2110/428 AND 2184/184. THIS EASEMENT WAS PARTIALLY TERMINATED ON 11/9/15; SEE RCRD 5669/0645.
B) 30' RIGHT OF WAY: SEE D-8806 AND 5446/2589.
C) MUTUAL PARKING AND ACCESS RIGHTS FOR LOTS 1-3 ON PLAN D-8806 ARE OF RECORD. RCRD 2343/128 AND 5446/2588.
- 9) UNDERGROUND UTILITY LOCATIONS ARE BASED UPON BEST AVAILABLE EVIDENCE AND ARE NOT FIELD VERIFIED. LOCATING AND PROTECTING ANY ABOVEGROUND OR UNDERGROUND UTILITIES IS THE SOLE RESPONSIBILITY OF THE CONTRACTOR AND/OR THE OWNER. UTILITY CONFLICTS SHOULD BE REPORTED AT ONCE TO THE DESIGN ENGINEER.
- 10) THE 2011 NHDOT LAFAYETTE ROAD PROJECT IDENTIFIED THIS ENCROACHMENT.

COMMERCIAL DEVELOPMENT
581 LAFAYETTE ROAD
PORTSMOUTH, N.H.

NO.	DESCRIPTION	DATE
2	CONTOURS, NOTE 6	1/24/24
1	ISSUED FOR APPROVAL	9/5/23
0	ISSUED FOR COMMENT	7/5/23

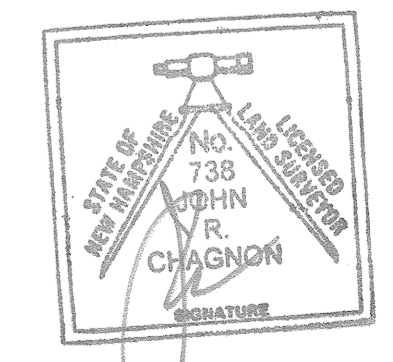

SCALE: 1"=20'

JULY 2023

EXISTING CONDITIONS PLAN

C1

GENERAL NOTES:

- 1) THE CONTRACTOR SHALL NOTIFY DIG SAFE AT 1-888-DIG-SAFE (1-888-344-7233) AT LEAST 72 HOURS PRIOR TO COMMENCING ANY EXCAVATION ON PUBLIC OR PRIVATE PROPERTY WITHIN 100 FEET OF UNDERGROUND UTILITIES. THE EXCAVATOR IS RESPONSIBLE TO MAINTAIN MARKS. DIG SAFE TICKETS EXPIRE IN THIRTY DAYS.
- 2) UNDERGROUND UTILITY LOCATIONS ARE BASED UPON BEST AVAILABLE EVIDENCE AND ARE NOT FIELD VERIFIED. LOCATING AND PROTECTING ANY ABOVEGROUND OR UNDERGROUND UTILITIES IS THE SOLE RESPONSIBILITY OF THE CONTRACTOR AND/OR THE OWNER. UTILITY CONFLICTS SHOULD BE REPORTED AT ONCE TO THE DESIGN ENGINEER.
- 3) CONTRACTOR SHALL INSTALL AND MAINTAIN EROSION CONTROL MEASURES IN ACCORDANCE WITH THE 'NEW HAMPSHIRE STORMWATER MANUAL, VOLUME 3, EROSION AND SEDIMENT CONTROLS DURING CONSTRUCTION. (NHDES DECEMBER 2008).

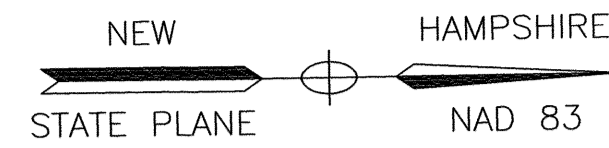

DEMOLITION NOTES

- A) THE LOCATIONS OF UNDERGROUND UTILITIES ARE APPROXIMATE AND THE LOCATIONS ARE NOT GUARANTEED BY THE OWNER OR THE DESIGNER. IT IS THE CONTRACTORS' RESPONSIBILITY TO LOCATE UTILITIES AND ANTICIPATE CONFLICTS. CONTRACTOR SHALL REPAIR EXISTING UTILITIES DAMAGED BY THEIR WORK AND RELOCATE EXISTING UTILITIES THAT ARE REQUIRED TO BE RELOCATED PRIOR TO COMMENCING ANY WORK IN THE IMPACTED AREA OF THE PROJECT.
- B) ALL MATERIALS SCHEDULED TO BE REMOVED SHALL BECOME THE PROPERTY OF THE CONTRACTORS UNLESS OTHERWISE SPECIFIED. THE CONTRACTOR SHALL DISPOSE OF ALL MATERIALS OFF-SITE IN ACCORDANCE WITH ALL FEDERAL, STATE, AND LOCAL REGULATIONS, ORDINANCES AND CODES. THE CONTRACTOR SHALL COORDINATE REMOVAL, RELOCATION, DISPOSAL, OR SALVAGE OF UTILITIES WITH THE OWNER AND APPROPRIATE UTILITY COMPANY.
- C) ANY EXISTING WORK OR PROPERTY DAMAGED OR DISRUPTED BY CONSTRUCTION/ DEMOLITION ACTIVITIES SHALL BE REPLACED OR REPAIRED TO THE ORIGINAL EXISTING CONDITIONS BY THE CONTRACTOR AT NO ADDITIONAL COST TO THE OWNER.
- D) THE CONTRACTOR SHALL VERIFY LOCATION OF ALL EXISTING UTILITIES AND CALL DIG SAFE AT LEAST 72 HOURS PRIOR TO THE COMMENCEMENT OF ANY DEMOLITION/CONSTRUCTION ACTIVITIES.
- E) SAWCUT AND REMOVE PAVEMENT ONE FOOT OFF PROPOSED EDGE OF PAVEMENT TRENCH IN AREAS WHERE PAVEMENT IS TO BE REMOVED.
- F) IT IS THE CONTRACTOR'S RESPONSIBILITY TO FAMILIARIZE THEMSELVES WITH THE CONDITIONS OF ALL THE PERMIT APPROVALS.
- G) THE CONTRACTOR SHALL NOTICE AND PAY FOR ADDITIONAL CONSTRUCTION PERMITS, NOTICES AND FEES NECESSARY TO COMPLETE THE WORK AND ARRANGE FOR AND PAY FOR ANY INSPECTIONS AND APPROVALS FROM THE AUTHORITIES HAVING JURISDICTION. THE CONTRACTOR SHALL BE RESPONSIBLE FOR ANY ADDITIONAL AND OFF-SITE DISPOSAL OF MATERIALS REQUIRED TO COMPLETE THE WORK.
- H) THE CONTRACTOR SHALL REMOVE AND DISPOSE OF ALL EXISTING STRUCTURES, CONCRETE, UTILITIES, VEGETATION, PAVEMENT, AND CONTAMINATED SOIL WITHIN THE WORK LIMITS SHOWN UNLESS SPECIFICALLY IDENTIFIED TO REMAIN. ANY EXISTING DOMESTIC / IRRIGATION SERVICE WELLS IN THE PROJECT AREA IDENTIFIED DURING THE CONSTRUCTION AND NOT CALLED OUT ON THE PLANS SHALL BE BROUGHT TO THE ATTENTION OF THE OWNER AND ENGINEER FOR PROPER CAPPING / RE-USE.
- I) PROVIDE INLET PROTECTION BARRIERS AT ALL CATCH BASINS WITHIN CONSTRUCTION LIMITS AND MAINTAIN FOR THE DURATION OF THE PROJECT. INLET PROTECTION BARRIERS SHALL BE HIGH FLOW SILT SACK BY ACT ENVIRONMENTAL OR APPROVED EQUAL. INSPECT BARRIERS WEEKLY AND AFTER EACH RAIN OF 0.25 INCHES OR GREATER. CONTRACTOR SHALL COMPLETE A MAINTENANCE INSPECTION REPORT AFTER EACH INSPECTION. SEDIMENT DEPOSITS SHALL BE REMOVED AFTER EACH STORM EVENT OR MORE OFTEN IF WARRANTED OR FABRIC BECOMES CLOGGED. EROSION CONTROL MEASURES SHALL BE INSTALLED PRIOR TO THE START OF ANY CLEARING OR DEMOLITION ACTIVITIES.
- J) THE CONTRACTOR SHALL PAY ALL COSTS NECESSARY FOR TEMPORARY PARTITIONING, BARRICADING, FENCING, SECURITY AND SAFETY DEVICES REQUIRED FOR THE MAINTENANCE OF A CLEAN AND SAFE CONSTRUCTION SITE.
- K) ANY CONTAMINATED MATERIAL REMOVED DURING THE COURSE OF THE WORK WILL REQUIRE HANDLING IN ACCORDANCE WITH NHDES REGULATIONS. CONTRACTOR SHALL HAVE A HEALTH AND SAFETY PLAN IN PLACE, AND COMPLY WITH ALL APPLICABLE PERMITS, APPROVALS, AUTHORIZATIONS, AND REGULATIONS.

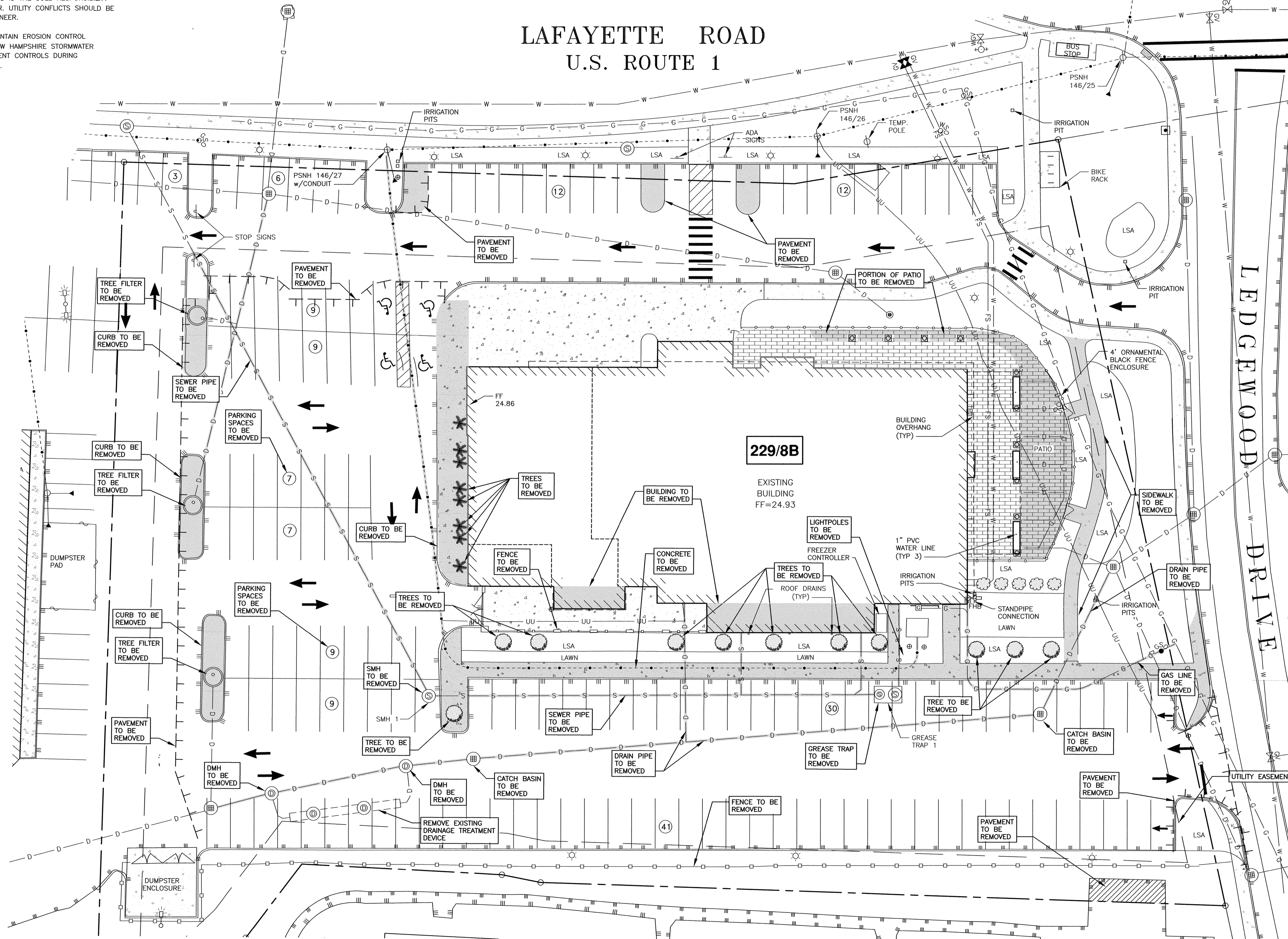

COMMERCIAL DEVELOPMENT
581 LAFAYETTE ROAD
PORTSMOUTH, N.H.

NO.	DESCRIPTION	DATE
2	BUILDING & SIDEWALK DEMO	2/21/24
1	ISSUED FOR APPROVAL	9/5/23
0	ISSUED FOR COMMENT	7/5/23

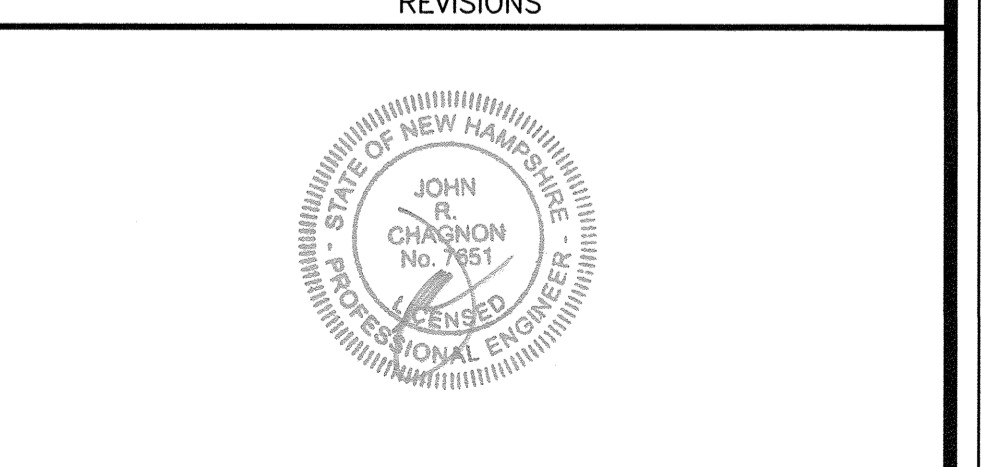

SCALE: 1"=20' JULY 2023

DEMOLITION PLAN

C2

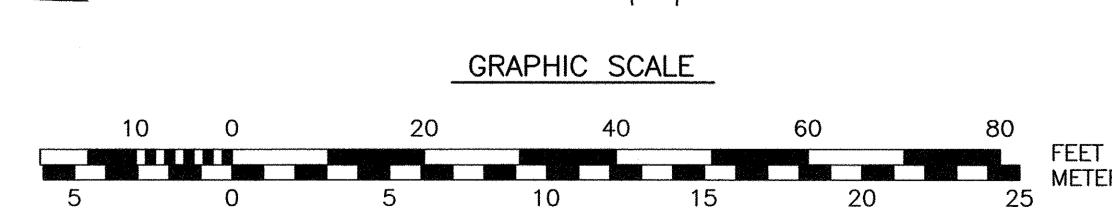

ZONING TABLE

Zone	Additions	proposed
	G1 allowed	
Height	G1 apartments: 5 stories or 60 ft per Density Bonus 10.5872.30; 4 stories or 50 ft (+ density bonus 1 story or 10') 10.58.22.20, at streets <60' row: 35' max <25' setback 45' max <50' setback 60' max >50' setback.	<35/3 stories at street fronts <45/4 stories beyond <50/5 stories at center: Building A: 56'-9 13/16" Building B: 57'-8 1/16"
Penthouses	10' above allowed building height	<10'
Roof appurtenance	Roof decks, roof gardens, and related structures and appurtenances shall not be counted in the building height limits	<10'
Facade Types	forecourt, recessed entry, dooryard, step, porch	recessed entry Workforce Housing: 4 stories Podium parking at street level and one level below grade
Building Types	Dwelling units	
Setbacks (ft) *	Front (principal) min 30' & max 37' from Lot Line at Ledgerwood	setback is within public way 39'
Side	Minimum side setback: 15 ft. Where a development site includes a more than one building type, the minimum building setback to interior lot lines shall be 0 feet	39'
Rear	N/A. Minimum rear setback: 20 ft. (& 25 ROW easement)	39'
Front lot line buildout residential	50%	85%
Front lot line buildout commercial/mixed-use	75%	85%
Frontage, Lafayette	100 ft min	337.4'
Lot area (sf)	NR	
area per dwelling	Workforce Housing units for rent: min 10% or 2 units, min. 300 sq ft or average unit size (larger of two)	WF units are larger than average unit size: >359 sf
Coverage, maximum	50%	80.1%
Footprint, max	NR for apartment buildings For developments located on public transit with year-round, 5-days-per-week, fixed-route service and where at least 50% of the building(s) are within 1/4 mile of a transit stop, the minimum offstreet parking shall be reduced by 20%.	See attached parking summary
Offstreet parking		
ground floor area per use, max	NR	parking
Open space, minimum	20%	21.8%
permitted uses (G1)	multifamily, restaurant	multifamily
building length, max (ft)	200	<200
façade modulation length, max (ft)	A) Symmetrical and vertically articulated bays >6' & <50' wide, minimum 3. B) Buildings greater than one hundred (100) feet in width shall read as a series of smaller buildings with varied architectural design and façade glazing patterns; or include a change in vertical plane of the façade of at least four (4) feet (in depth or projection) for at least one (1) bay in width for every one hundred (100) feet of total façade width. This change in plane applies to the entire height of the façade.	modulations < 100 ft
entrance spacing, max (ft)		both entries are facing street fronts
floor height above sidewalk, max	36"	8"
ground floor height, min		12"
second floor height, min		11"
glazing, shopfront, min	20%	entrances 100%. Sides & rear: podium parking at first floor, some open and some screening
glazing, other	NR	
roof types (pitch)	structural expression of the building façade and its materials	Flat & Sloped
Parking, off-street;	1 bicycle space for each 5 dwellings units or portion thereof. Off-site parking: Less than 500 sq. ft. 0.5 spaces per unit. 500-700 sq. ft. 1.0 space per unit. Over 750 sq. ft. 1.3 space per unit. 10.1112.312 In addition to the off-street parking spaces provided in accordance with Sec. 10.1112.311, any dwelling or group of dwelling on a lot containing more than 4 dwelling units shall provide one visitor parking space for every 5 dwelling units or portion thereof.	See attached parking summary
Units density	24 units per building, 36 units exception for workforce housing Conditional Use Permit under the provisions for Density Bonuses in Section 10.5872&10.5872	36 units per building * 2 buildings = 72 units

IMPERVIOUS SURFACE AREAS (TO PROPERTY LINE)

STRUCTURE	POST-CONSTRUCTION IMPERVIOUS (S.F.)
MAIN STRUCTURE	43179
SIDEWALK	3,946
PAVEMENT	30,812
CURB	266
RETAINING WALL	368
TOTAL	78571
LOT SIZE	98,124
% IMPERVIOUS SURFACE	80.1%

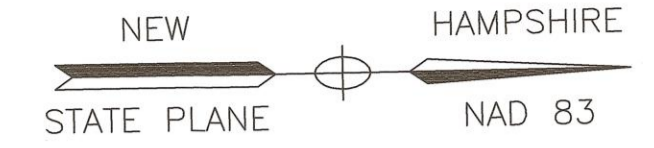

LAFAYETTE ROAD
U.S. ROUTE 1

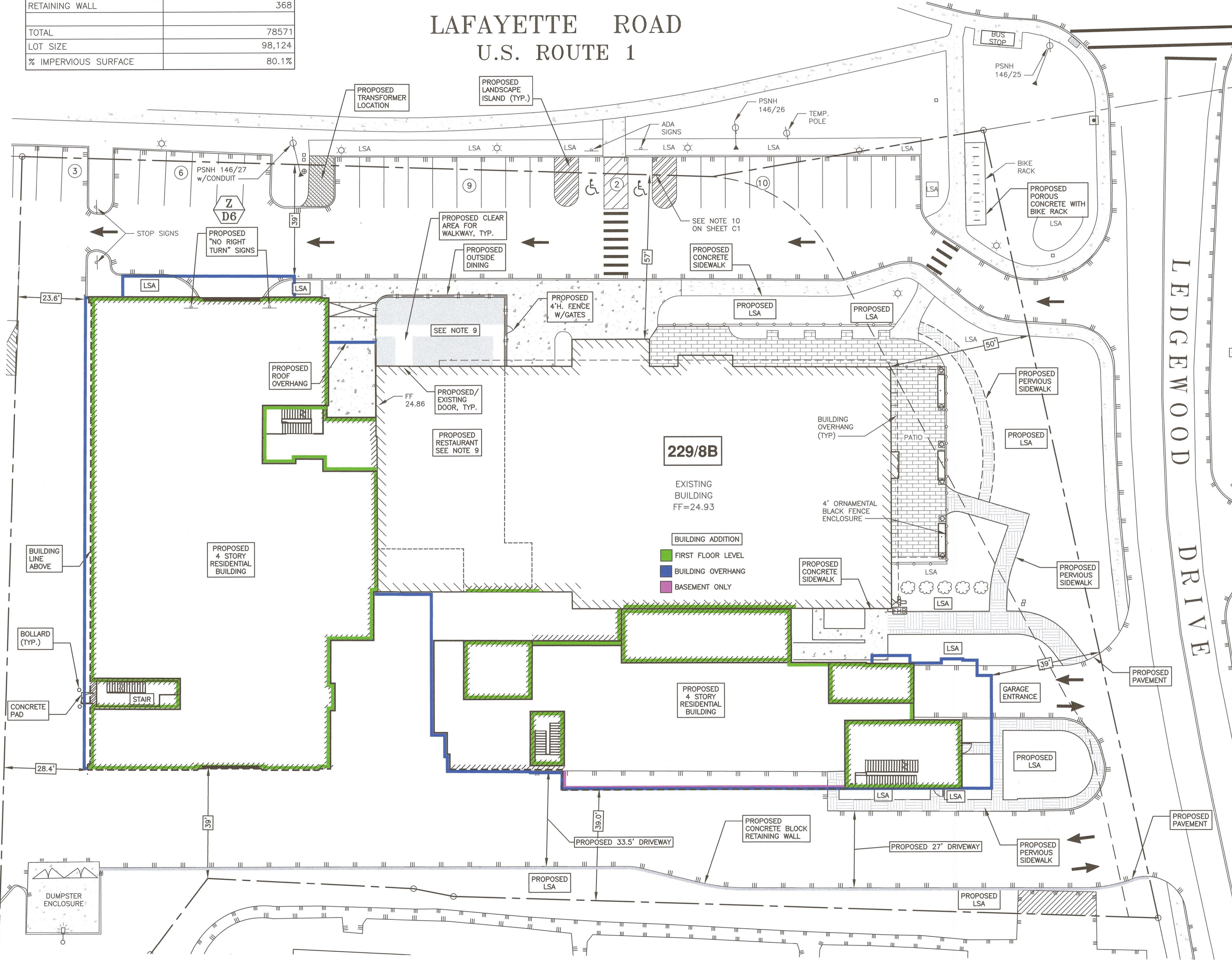

229/8B

EXISTING BUILDING
FF=24.93

- BUILDING ADDITION
- FIRST FLOOR LEVEL
- BUILDING OVERHANG
- BASEMENT ONLY

PORTSMOUTH APPROVAL CONDITIONS

- NOTES:
- ALL CONDITIONS ON THIS PLAN SET SHALL REMAIN IN EFFECT IN PERPETUITY PURSUANT TO THE REQUIREMENTS OF THE CITY OF PORTSMOUTH SITE PLAN REVIEW REGULATIONS.
 - THIS SITE PLAN SHALL BE RECORDED IN THE ROCKINGHAM COUNTY REGISTRY OF DEEDS.
 - ALL IMPROVEMENTS SHOWN ON THIS SITE PLAN SHALL BE CONSTRUCTED AND MAINTAINED IN ACCORDANCE WITH THE PLAN BY THE PROPERTY OWNER AND ALL FUTURE PROPERTY OWNERS. NO CHANGES SHALL BE MADE TO THIS SITE PLAN WITHOUT THE EXPRESS APPROVAL OF THE PORTSMOUTH PLANNING DIRECTOR.

200 Griffin Road, Unit 3
Portsmouth, NH 03801
603.430.9282

WWW.HALEYWARD.COM

NOTES:

- PARCEL IS SHOWN ON THE CITY OF PORTSMOUTH ASSESSOR'S MAP 229 AS LOT 8B.
- OWNERS OF RECORD:
ATLAS COMMONS, LLC
3 PLEASANT STREET, SUITE 400
PORTSMOUTH, NH 03801
6474/1538
- THE PARCEL IS NOT IN A FLOOD HAZARD ZONE AS SHOWN ON FIRM PANEL 3301500270E, EFFECTIVE MAY 17, 2005
- EXISTING LOT AREA:
98,124 S.F.
2.2526 AC
- PARCEL IS LOCATED IN THE GATEWAY NEIGHBORHOOD CORRIDOR (G1) DISTRICT.
- DIMENSIONAL REQUIREMENTS:
SEE ZONING ORDINANCE SECTION 10.5B22.10
- THE PURPOSE OF THIS PLAN IS TO SHOW A PROPOSED BUILDING ADDITION ON TAX MAP 229 LOT 8B.
- DESIGN BASED ON ARCHITECTURAL PLAN BY ARCOVE ARCHITECTS DATED 2/21/24.
- CONVERSION OF TUSCAN MARKETPLACE TO RESTAURANT (NORTHEASTERN THAI, LLC) APPROVED UNDER PERMIT: LU-22-254

COMMERCIAL DEVELOPMENT
581 LAFAYETTE ROAD
PORTSMOUTH, N.H.

NO.	DESCRIPTION	DATE
6	BUILDING REVISION, PARKING LAYOUT	2/21/24
5	SIGNAGE	2/6/24
4	TABLES & PARKING	1/24/24
3	LANDSCAPE AREA, IMPERVIOUS TABLE	1/2/24
2	IMPERVIOUS SURFACE TABLE	12/19/23
1	ISSUED FOR APPROVAL	11/20/23
0	ISSUED FOR COMMENT	8/31/23

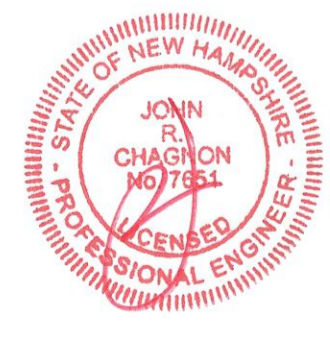
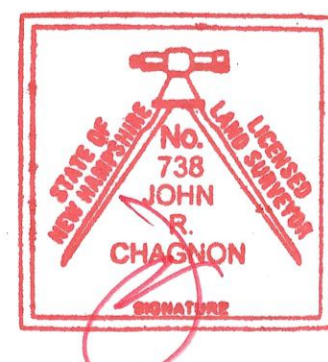

SCALE: 1"=20'

JULY 2023

APPROVED BY THE PORTSMOUTH PLANNING BOARD

CHAIRMAN _____ DATE _____

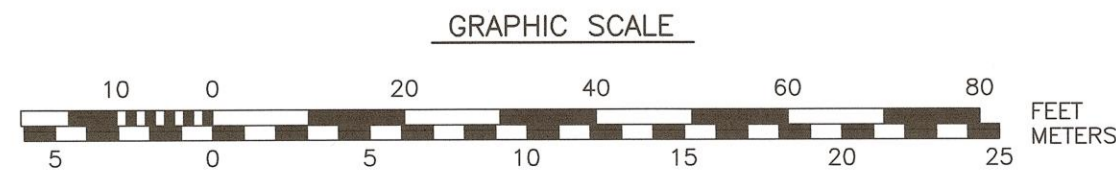

SITE PLAN

C3

Plant List - Off-Site Perennials

ID	Qty	Botanical Name	Common Name	Scheduled Size
AND	925	Andropogon ger. 'Blackhawks'	Big Bluestem	Plugs
BAP	15	Baptisia australis 'Screaming Yellow'	False Indigo	2 QT
DES	43	Deschampsia cespitosa	Tussock Grass	1 Gal.
ERA	30	Eragrostis spectabilis	Purple Lovegrass	2 QT
GMB	16	Geranium macrorrhizum 'Bevan's'	Cranesbill	2 QT
LIA	363	Liatris spicata	Gayfeather	2 QT
PVS	63	Panicum virgatum 'Shenandoah'	Shenandoah Switch Grass	2 Gal.
RF	13	Rudbeckia fulgida 'Goldstrum'	Goldstrum Black-Eyed Susan	2 QT
SH	45	Sporobolus heterolepis	Prairie Dropseed	1 Gal.
XAN	2	Xanthorhiza simplicissima	Yellowroot	2 QT

Plant List - Off-Site Trees + Shrubs

ID	Qty	Botanical Name	Common Name	Scheduled Size
CK	3	Cladrastis kentuckea	Yellowwood	2 1/2" Cal.
CR	20	Cornus racemosa	Grey Dogwood	5 Gal.
HAL	2	Halesia carolina 'Jersey Belle'	Jersey Belle Carolina Silverbelle	1 1/2" Cal.
HYP	12	Hypericum 'Hidcote'	St. Johnswort	5 Gal.
JBD	25	Juniperus communis depressa 'AmiDak'	Blueberry Delight Juniper	2 Gal.
JES	6	Juniperus virginiana 'Emerald Sentinel'	Emerald Sentinel Red Cedar	3" Cal.
MG	31	Myrica gale	Sweetgale	2 Gal.
MP	26	Myrica pensylvanica	Northern Bayberry	2 Gal.
NS	4	Nyssa sylvatica	Black Tupelo	3" Cal.
OV	2	Ostrya virginiana	American Hophornbeam	2-2.5" Cal.
RGL	187	Rhus aromatica 'Grow Low'	Grow Low Sumac	18"+ Ht.
RYC	5	Rhododendron yaku. 'Crete'	Yaku Crete Rhododendron	3-4'
SA	6	Sassafras albidum	Sassafras	3 1/2" Cal.
VTC	3	Viburnum trilobum 'Compacta'	Compact American Cranberry Viburnum	4-5'



NOTE: IRRIGATION IN THE FORM OF SPRINKLER HEADS IN THE LAWN AREAS AND DRIP IRRIGATION IN PLANTING BEDS SHALL BE SOURCED FROM THE CITY OF PORTSMOUTH'S MUNICIPAL WATER, AND SHALL INCLUDE A BACK FLOW PREVENTION.

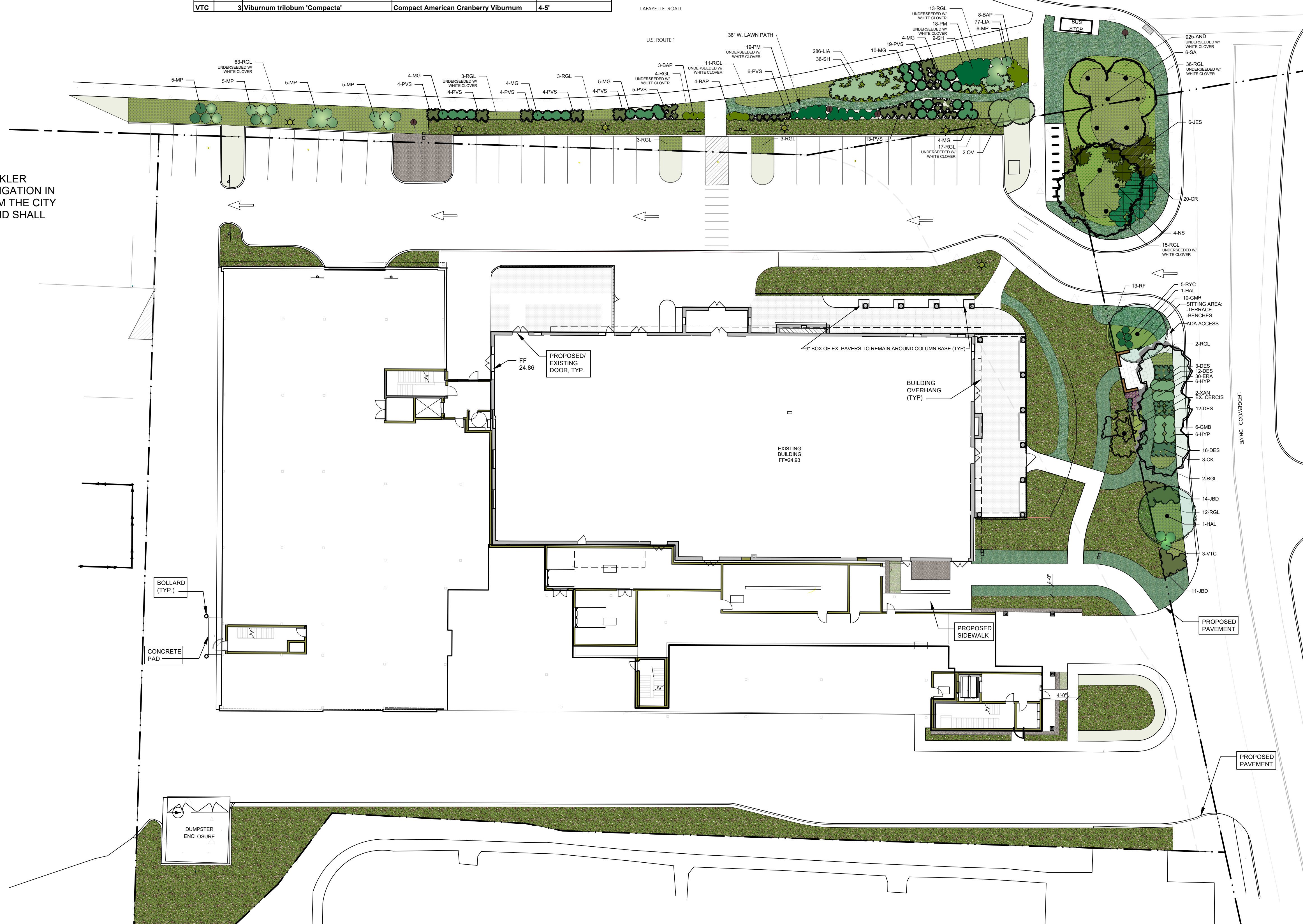

No.	Date	By	Revision Notes
E	2/21/2024		PLANNING SUBMISSION
D	2/14/2024		T+G COMMENTS (GATE REMOVAL)
C	2/12/2024		COMMUNITY SPACE DESIGN
B	1/10/2024		TREES + GREENERY COMMENTS
A	1/2/2024		TAC COMMENTS

No.	Date	Issue Notes

Design Firm	terra firma landscape architecture 163.a Court Street Portsmouth, NH
Consultant	
Project Title	581 LAFAYETTE
Sheet Title	Off-Site Community Space Landscape Plan
Project Manager	Project ID: 581 LAFAYETTE
Drawn By: TC	Scale: 1:240
Reviewed By: TP	Sheet No. L-1B
Date: 11/20/2023	of 2
CAD File Name: 581LAFAYETTE2024.vwx	

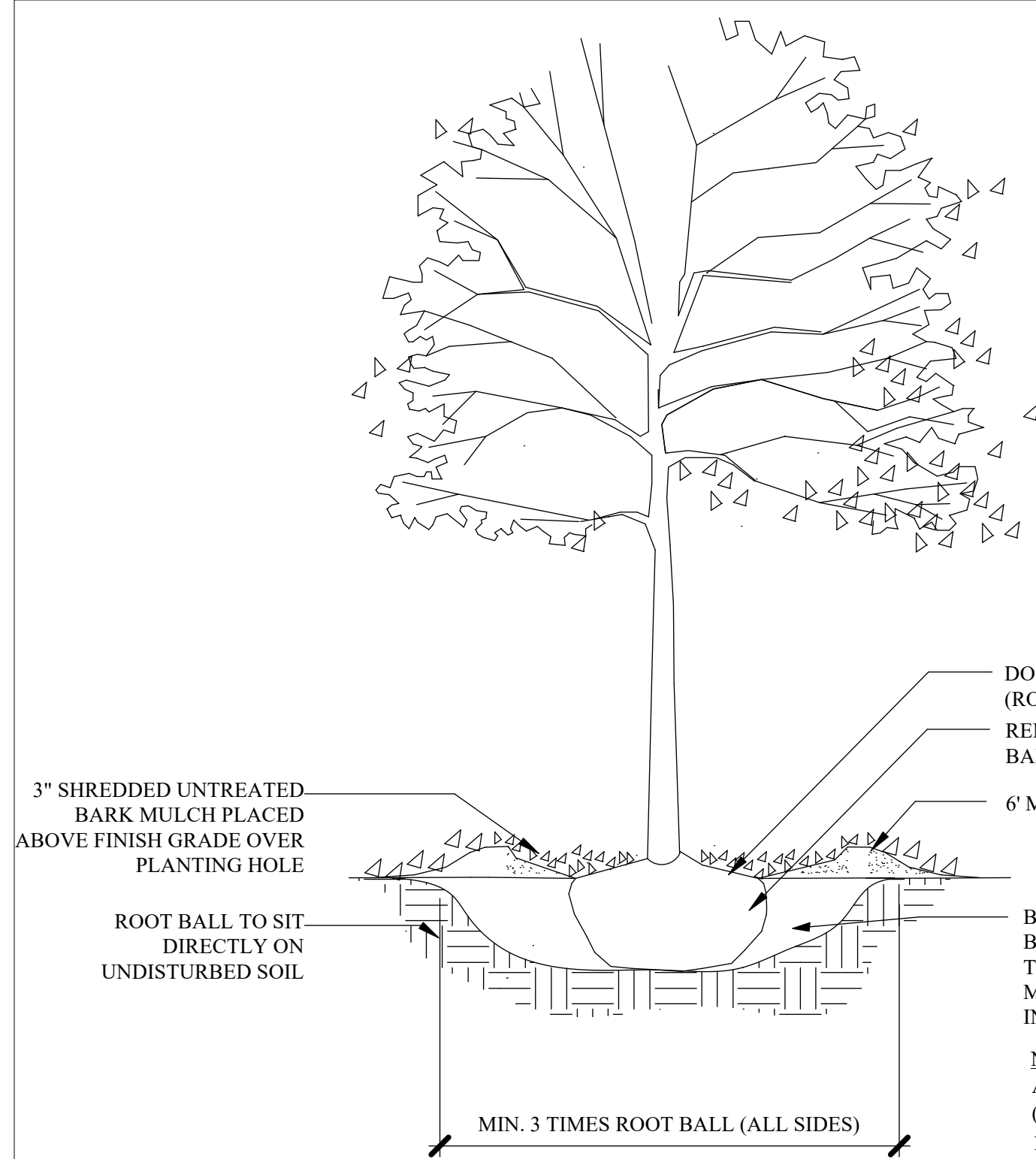
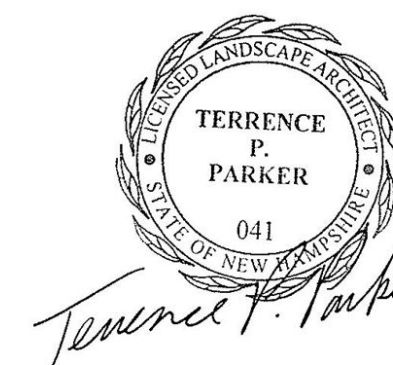

1
L-2 **TREE PLANTING - 2"+ CAL.**
SCALE: NTS

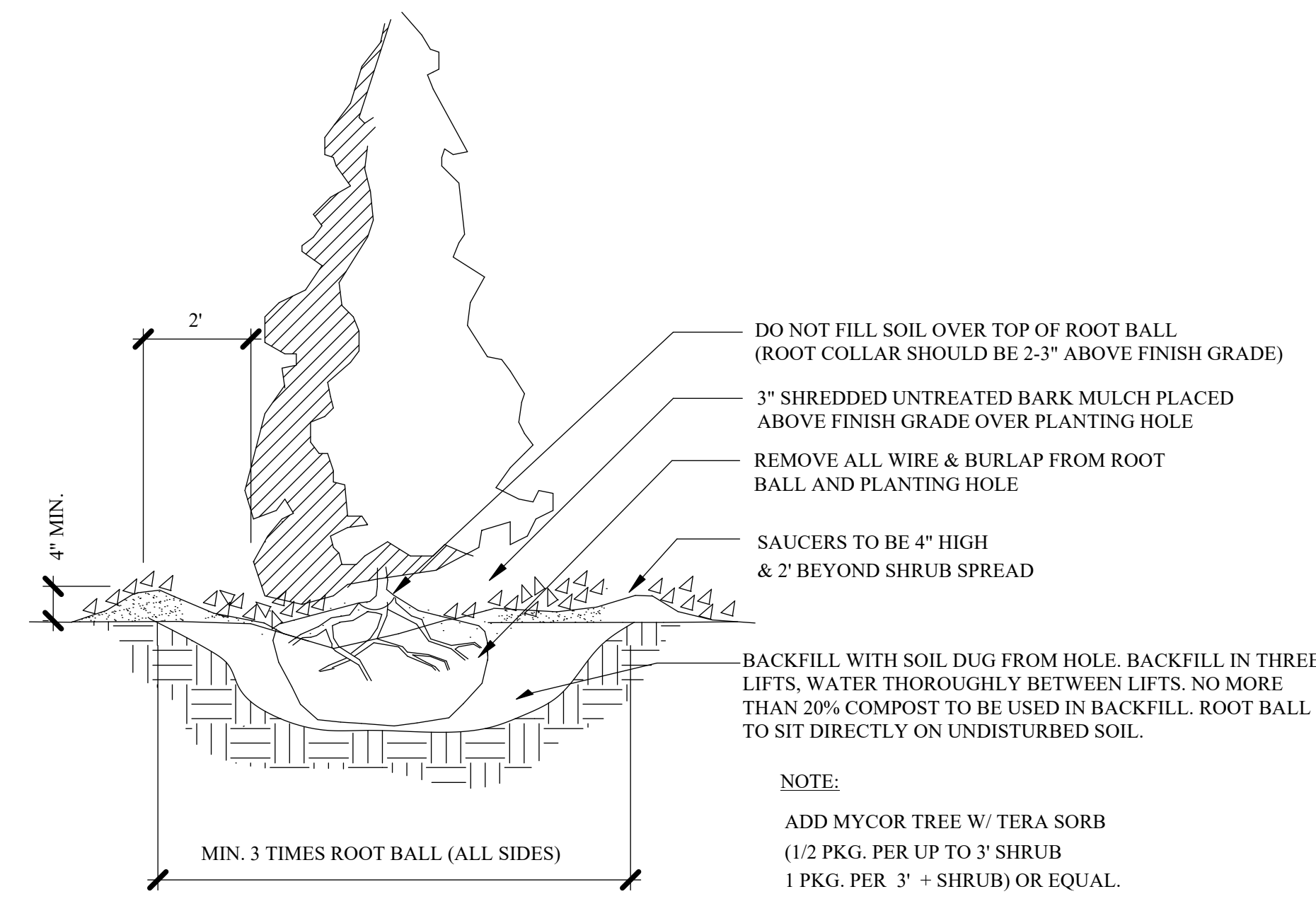

2
L-2 **PYRAMIDAL EVERGREEN TREE PLANTING**
SCALE: NTS

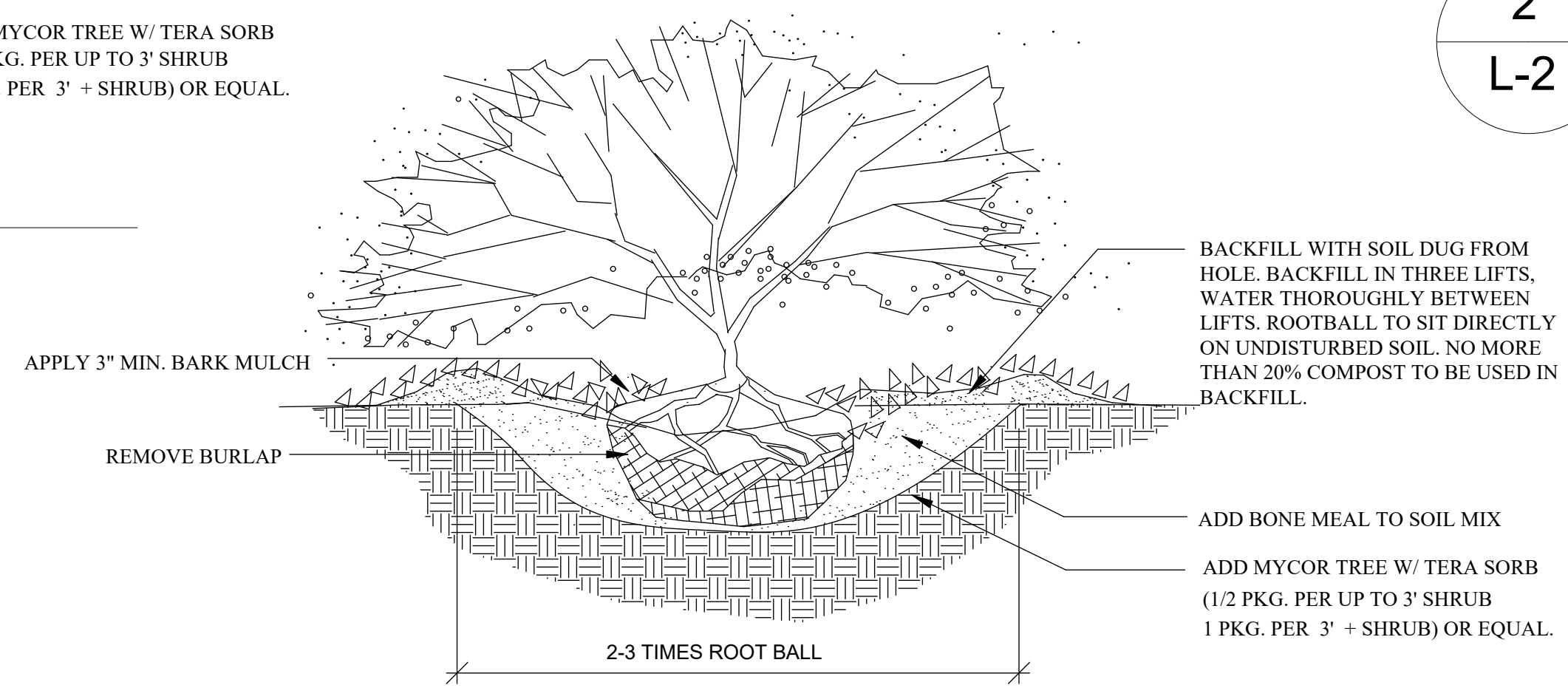

3
L-2 **B&B SHRUB PLANTING**
SCALE: NTS

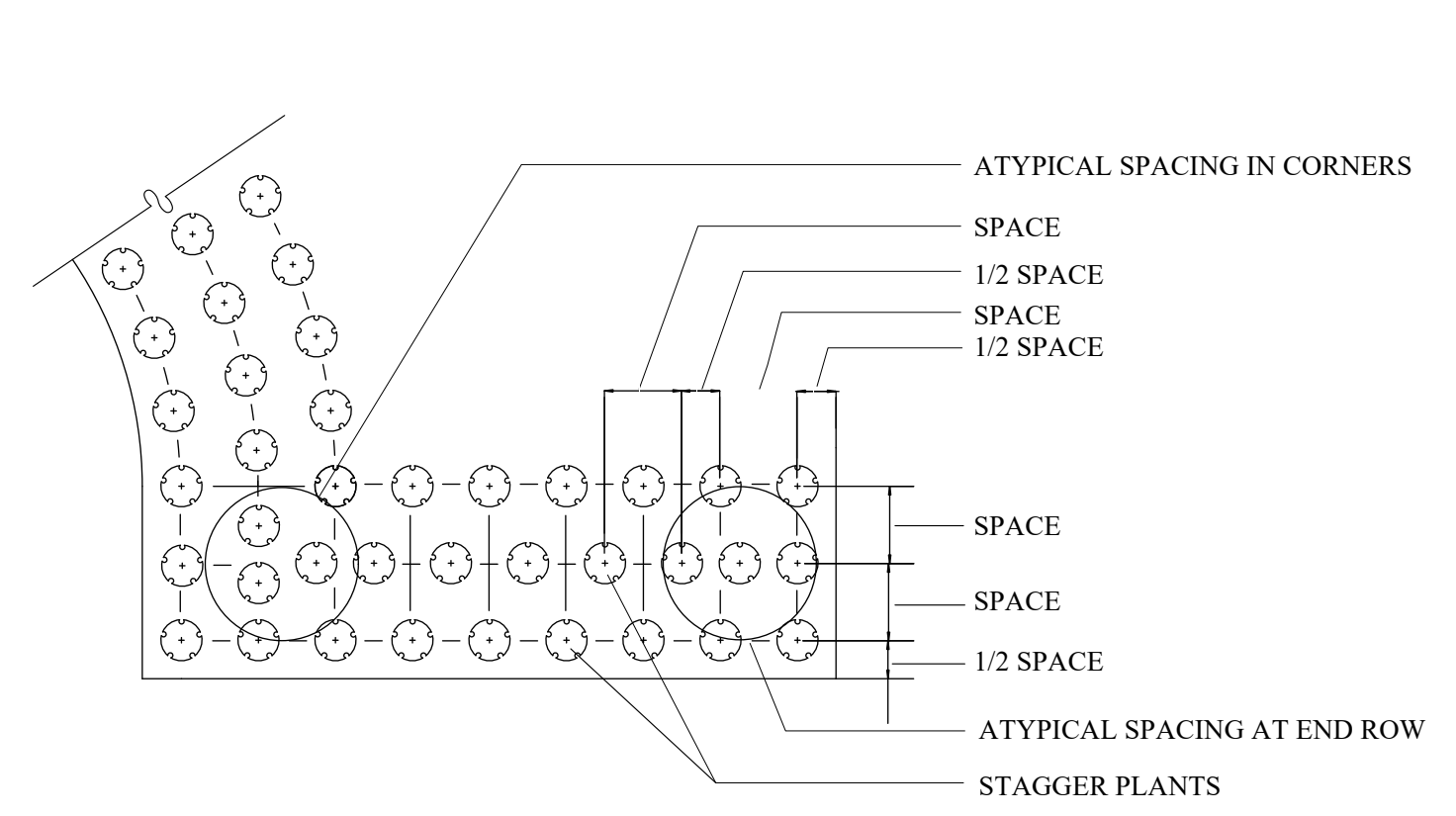

NOTES:
1. PLACE PLANTS IN BED AS SHOWN, SPACING AS SPECIFIED IN PLANT SCHEDULE.
2. GROUND COVER SHALL BE TRIANGULAR SPACED IN ROWS PARALLEL TO STRAIGHT EDGES AND SHALL BE EVENLY SPACED IN ROWS PARALLEL TO CURVE EDGES.

4
L-2 **GROUND COVER SPACING DETAIL**
SCALE: NTS

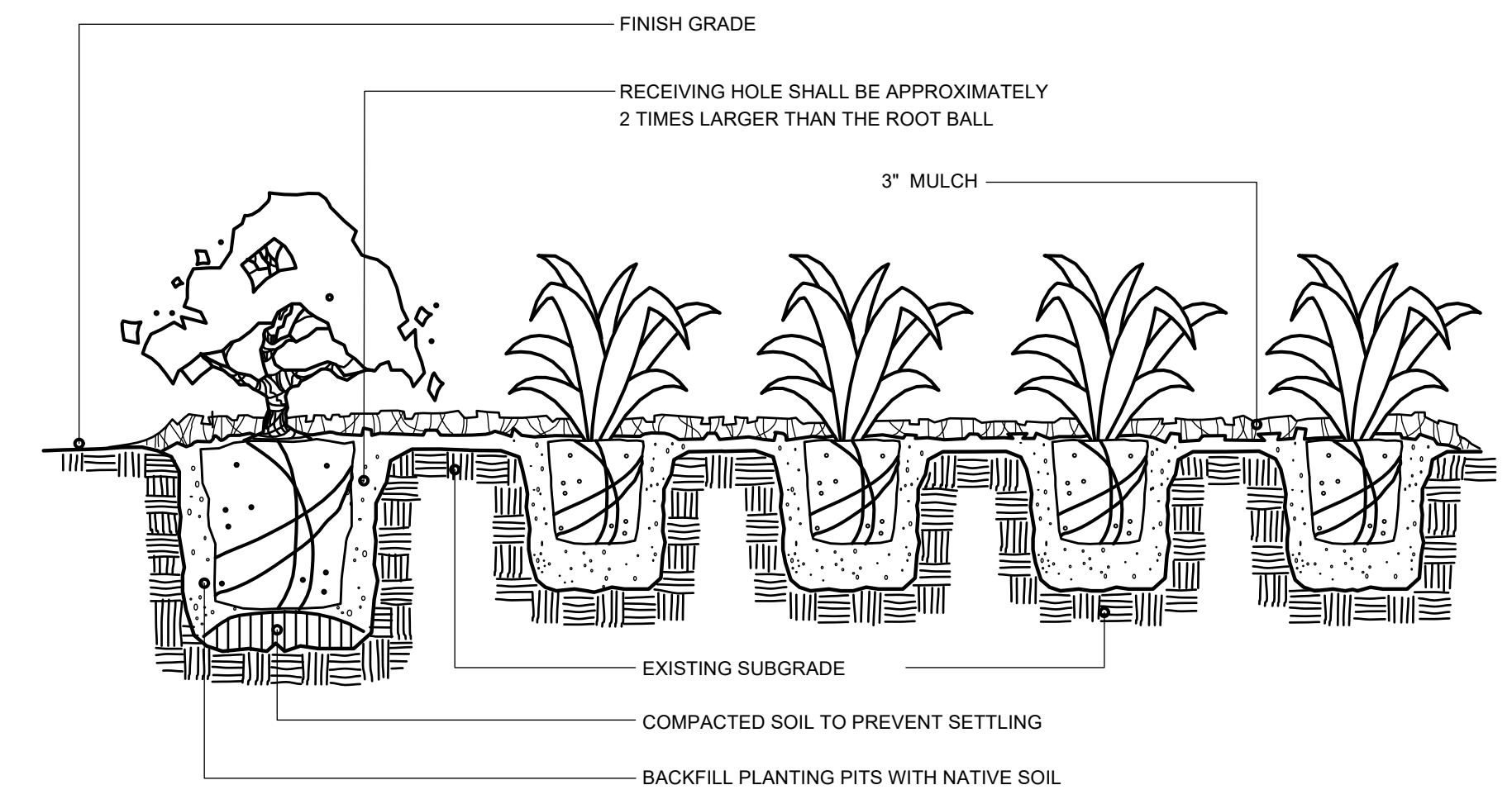

5
L-2 **SHRUB/GROUND COVER PLANTING DETAIL**
SCALE: NTS

LANDSCAPE NOTES:

1. THE CONTRACTOR SHALL LOCATE AND VERIFY THE EXISTENCE OF ALL UTILITIES PRIOR TO STARTING WORK.
2. THE CONTRACTOR SHALL SUPPLY ALL PLANT MATERIALS IN QUANTITIES SUFFICIENT TO COMPLETE THE PLANTINGS SHOWN ON THE DRAWINGS.
3. ALL MATERIAL SHALL CONFORM TO THE GUIDELINES ESTABLISHED BY THE CURRENT AMERICAN STANDARD FOR NURSERY STOCK PUBLISHED BY THE AMERICAN ASSOCIATION OF NURSERYMEN.
4. ALL PLANT SUBSTITUTIONS MUST BE APPROVED BY THE LANDSCAPE ARCHITECT.
5. ALL PLANT MATERIALS SHALL BE EXACTLY AS SPECIFIED BY THE LANDSCAPE ARCHITECT. IF PLANT SPECIES CULTIVARS ARE FOUND TO VARY FROM THAT SPECIFIED AT ANY TIME DURING THE GUARANTEE PERIOD, THE LANDSCAPE ARCHITECT RESERVES THE RIGHT TO HAVE THE CONTRACTOR REPLACE THAT PLANT MATERIAL. THE LANDSCAPE ARCHITECT RESERVES THE RIGHT TO REJECT ANY PLANT DELIVERED TO THE SITE FOR AESTHETIC REASONS BEFORE PLANTING. THE LANDSCAPE CONTRACTOR IS RESPONSIBLE FOR THE QUALITY FOR ALL THE PLANTS.
6. PLANTS SHALL BE SUBJECT TO INSPECTION AND APPROVAL AT THE PLACE OF GROWTH, UPON DELIVERY OR AT THE JOB SITE WHILE WORK IS ON-GOING TO CONFORMITY TO SPECIFIED QUALITY, SIZE AND VARIETY.
7. PLANTS FURNISHED IN CONTAINERS SHALL HAVE THE ROOTS WELL ESTABLISHED IN THE SOIL MASS AND SHALL HAVE AT LEAST ONE (1) GROWING SEASON. ROOT-BOUND PLANTS OR INADEQUATELY SIZED CONTAINERS TO SUPPORT THE PLANT MAY BE DEEMED UNACCEPTABLE.
8. NO PLANT SHALL BE PUT IN THE GROUND BEFORE GRADING HAS BEEN FINISHED AND APPROVED BY THE LANDSCAPE ARCHITECT.
9. ALL PLANTS SHALL BE INSTALLED AND DETAILED PER PROJECT SPECIFICATIONS.
10. ALL PLANTS SHALL BE WATERED THOROUGHLY TWICE DURING THE FIRST 24-HOUR PERIOD AFTER PLANTING. ALL PLANTS SHALL BE WATERED WEEKLY, OR MORE OFTEN IF NECESSARY, DURING THE FIRST GROWING SEASON.
11. ALL PLANTS SHALL BE GUARANTEED BY THE CONTRACTOR FOR NOT LESS THAN ONE FULL YEAR FROM THE TIME OF PROVISIONAL ACCEPTANCE. DURING THIS TIME, THE OWNER SHALL MAINTAIN ALL PLANT MATERIALS IN THE ABOVE MANNER. IT IS THE CONTRACTOR'S RESPONSIBILITY TO INSPECT THE PLANTS TO ENSURE PROPER CARE. IF THE CONTRACTOR IS DISSATISFIED WITH THE CARE GIVEN, HE SHALL IMMEDIATELY, AND IN SUFFICIENT TIME TO PERMIT THE CONDITION TO BE RECTIFIED, NOTIFY THE LANDSCAPE ARCHITECT IN WRITING OR OTHERWISE FORFEIT HIS CLAIM. LANDSCAPE CONTRACTOR SHALL PRUNE PLANTINGS OF DEAD LIMBS OR TWIGS DURING THE FIRST YEAR OF GROWTH.
12. FINAL ACCEPTANCE BY THE LANDSCAPE ARCHITECT WILL BE MADE UPON THE CONTRACTOR'S REQUEST AFTER ALL CORRECTIVE WORK HAS BEEN COMPLETED.
13. LANDSCAPE CONTRACTOR SHOULD REPLACE DEAD PLANTINGS IMMEDIATELY UPON OWNER DIRECTION WITHIN THE WARRANTY PERIOD AND AGAIN AT THE END OF THE GUARANTEE PERIOD. THE CONTRACTOR SHALL HAVE REPLACED ANY PLANT MATERIAL THAT IS MISSING, NOT TRUE TO SIZE AS SPECIFIED, THAT HAVE DIED, THAT HAVE LOST THEIR NATURAL SHAPE DUE TO DEAD BRANCHES, EXCESSIVE PRUNING OR INADEQUATE OR IMPROPER CARE, OR THAT ARE, IN THE OPINION OF THE LANDSCAPE ARCHITECT, IN UNHEALTHY OR UNSIGHTLY CONDITION.
14. ALL LANDSCAPE AREAS TO BE GRASS COMMON TO REGION EXCEPT FOR INTERIOR LANDSCAPED ISLANDS OR WHERE OTHER PLANT MATERIAL IS CALLED FOR.
15. ALL TREES AND SHRUBS TO BE PLANTED IN MULCH BEDS WITH DEFINED AND CUT EDGES TO SEPARATE TURF GRASS AREAS.
16. FOR ANY LANDSCAPE AREA SO DESIGNATED TO REMAIN, WHETHER ON OR OFF-SITE, REMOVE WEEDS, ROCKS, CONSTRUCTION ITEMS, ETC., THEN APPLY GRASS SEED OR PINE BARK MULCH AS DEPICTED ON PLANS.
17. LANDSCAPE CONTRACTOR SHALL FEED AND PRUNE EX. TREES, ON OR JUST OFF SITE, THAT HAVE EXPERIENCED ROOT BASE INTRUSION OR DAMAGE DURING CONSTRUCTION IMMEDIATELY AND FOR THE DURATION OF THE WARRANTY PERIOD AT THE DIRECTION OF THE LANDSCAPE ARCHITECT.
18. EXISTING TREES TO REMAIN SHALL BE PROTECTED WITH TEMPORARY SNOW FENCING AT THE EDGE OF THE EX. TREE CANOPY THE CONTRACTOR SHALL NOT STORE VEHICLES OR MATERIALS WITHIN THE LANDSCAPED AREAS. ANY DAMAGE TO EXISTING TREES, SHRUBS OR LAWN SHALL BE REPAIRED BY THE CONTRACTOR AT NO ADDITIONAL COST TO THE OWNER.
19. ALL MULCH AREAS SHALL RECEIVE A 2-3" LAYER OF SHREDDED PINE BARK MULCH.
20. ALL WORK SHALL BE DONE IN STRICT ACCORDANCE WITH PROJECT SPECIFICATIONS.
21. ALL PLANTING HOLES TO BE HAND-DUG, EXCEPT IN NEW CONSTRUCTION WITH NEW PLANTING PITS, PLANTING NEAR CURBS, OR AREAS WHERE SILVA CELLS WILL BE USED. IF HOLES ARE MACHINE-DUG, BOTTOM OF HOLES NEED TO BE THE APPROPRIATE HEIGHT, AND FIRMED BY THE MACHINE TO CREATE STABILITY FOR THE PLANT MATERIAL.

PLEASE NOTE: THIS SHEET IS SCALED FOR 22 BY 34 PAPER, DO NOT REDUCE OR ENLARGE.

No.	Date	By	Revision Notes

No.	Date	Issue Notes
E	2/21/2024	PLANNING SUBMISSION
D	2/14/2024	T+G COMMENTS (GATE REMOVAL)
C	2/12/2024	COMMUNITY SPACE DESIGN
B	1/10/2024	TREES + GREENERY COMMENTS
A	1/2/2024	TAC COMMENTS

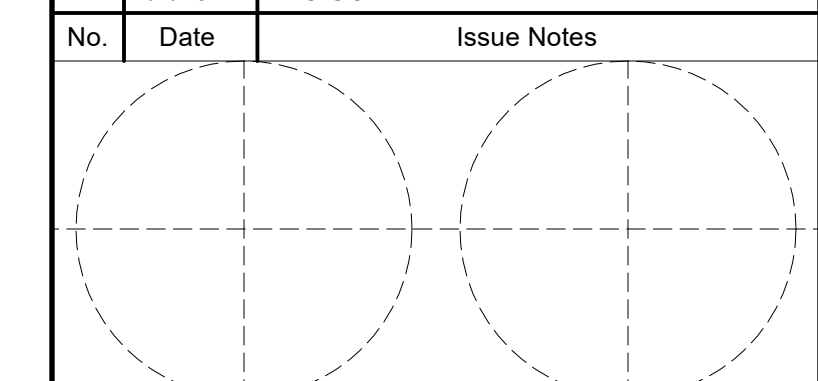

Design Firm: terra firma landscape architecture
163.a Court Street
Portsmouth, NH

Consultant: 581 LAFAYETTE

Project Title: 581 LAFAYETTE

Sheet Title	
Landscape Details	
Project Manager	Project ID: 581 LAFAYETTE
Drawn By: TC	Scale: AS NOTED
Reviewed By: TP	Sheet No.: L-2
Date: 11/20/2023	of 2
CAD File Name: 581LAFAYETTE22024.vwx	2

Symbol	Qty	Label	Arrangement	Description	[MANUFAC]	Tag
	6	B3	Single	WAT44-AC-36NB-80-3K-UNV-DIR3-PT-FINISH	BEACON PRODUCTS	EXISTING
	11	PL	Single	EL188-3L3KUV-H70	KIM LIGHTING	EXISTING
	4	W1	Single	LEW-30001-5.5W-T4-W30-CXX	LIGMAN	PROPOSED
	2	W2	Single	UGN-30081-72W-W30-XX-120/277V	LIGMAN	PROPOSED
	2	W3	Single	LEW-30021-20W-T3-W30-CXX	LIGMAN	PROPOSED
	5	W4	Single	LEW-30021-28W-T4-W30-CXX	LIGMAN	PROPOSED

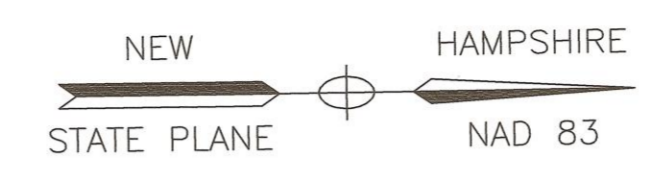

LAFAYETTE ROAD U.S. ROUTE 1

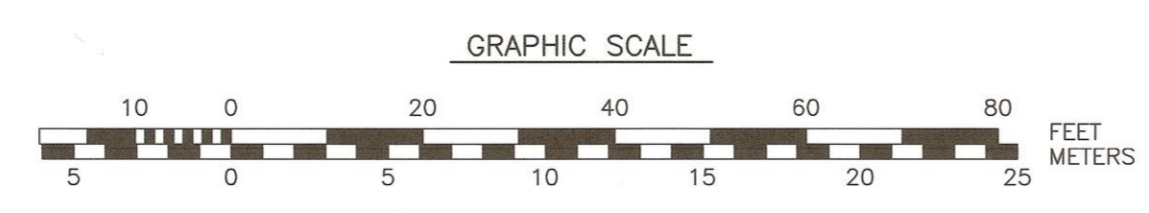
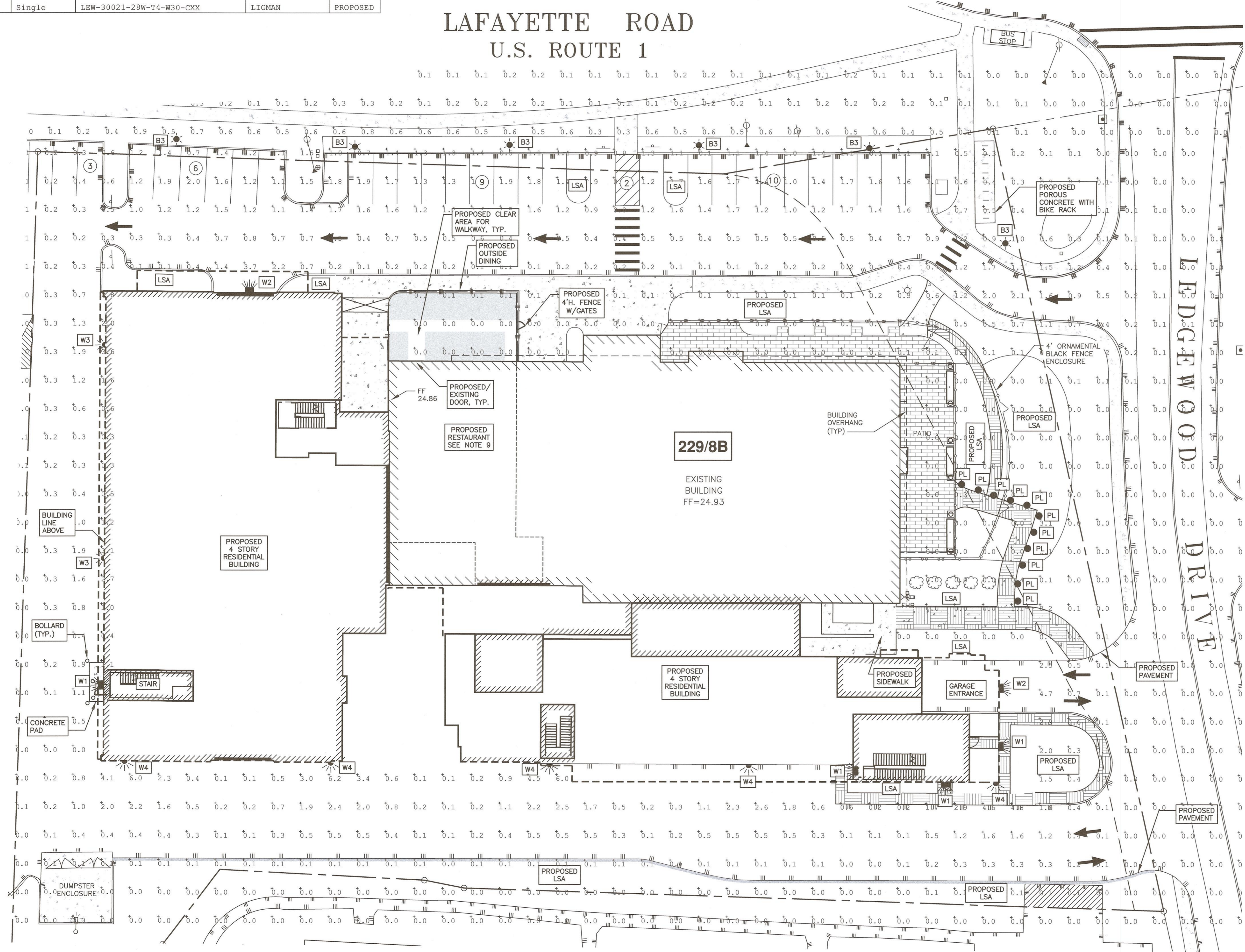

- NOTES:**
- PARCEL IS SHOWN ON THE CITY OF PORTSMOUTH ASSESSOR'S MAP 229 AS LOT 8B.
 - OWNERS OF RECORD:
ATLAS COMMONS, LLC
3 PLEASANT STREET, SUITE 400
PORTSMOUTH, NH 03801
6474/1538
 - THE PURPOSE OF THIS PLAN IS TO SHOW PROPOSED LIGHTING ON TAX MAP 229 LOT 8B.

COMMERCIAL DEVELOPMENT 581 LAFAYETTE ROAD PORTSMOUTH, N.H.

NO.	DESCRIPTION	DATE
1	BUILDING	2/21/24
0	ISSUED FOR APPROVAL	1/24/24

REVISIONS	

SCALE: 1"=20' JULY 2023

LIGHTING PLAN L3

P:\NH\010105-Michalski-Properties\1397.03-Lafayette Rd., Portsmouth -R\C\2023 Site Plan 1397.03\Plan & Specs\SitePlan.dwg, 2/22/2024, 3:48:43 PM, Portsmouth Planner, 1730303.dwg

NOTES:

- 1) PARCEL IS SHOWN ON THE CITY OF PORTSMOUTH ASSESSOR'S MAP 229 AS LOT 8B.
- 2) OWNERS OF RECORD:
ATLAS COMMONS, LLC
3 PLEASANT STREET, SUITE 400
PORTSMOUTH, NH 03801
6474/1538
- 3) THE PURPOSE OF THIS PLAN IS TO SHOW PARKING IN GENERAL FOR THE PROPOSED SITE DEVELOPMENT ON ASSESSOR'S MAP 229 LOT 8B IN THE CITY OF PORTSMOUTH.
- 4) TANDEM SPACES SHALL BE ASSIGNED TO PARTICULAR UNITS TO CONFORM TO SECTION 10.1114.33
- 5) IF THE NHDOT REQUIRES THE PARKING ENCROACHMENT ON ROUTE 1 TO BE ELIMINATED AND THE PARKING NEEDS TO BE REVISED THEN THE ALTERNATIVE PARKING LAYOUT WILL BE CONSTRUCTED.

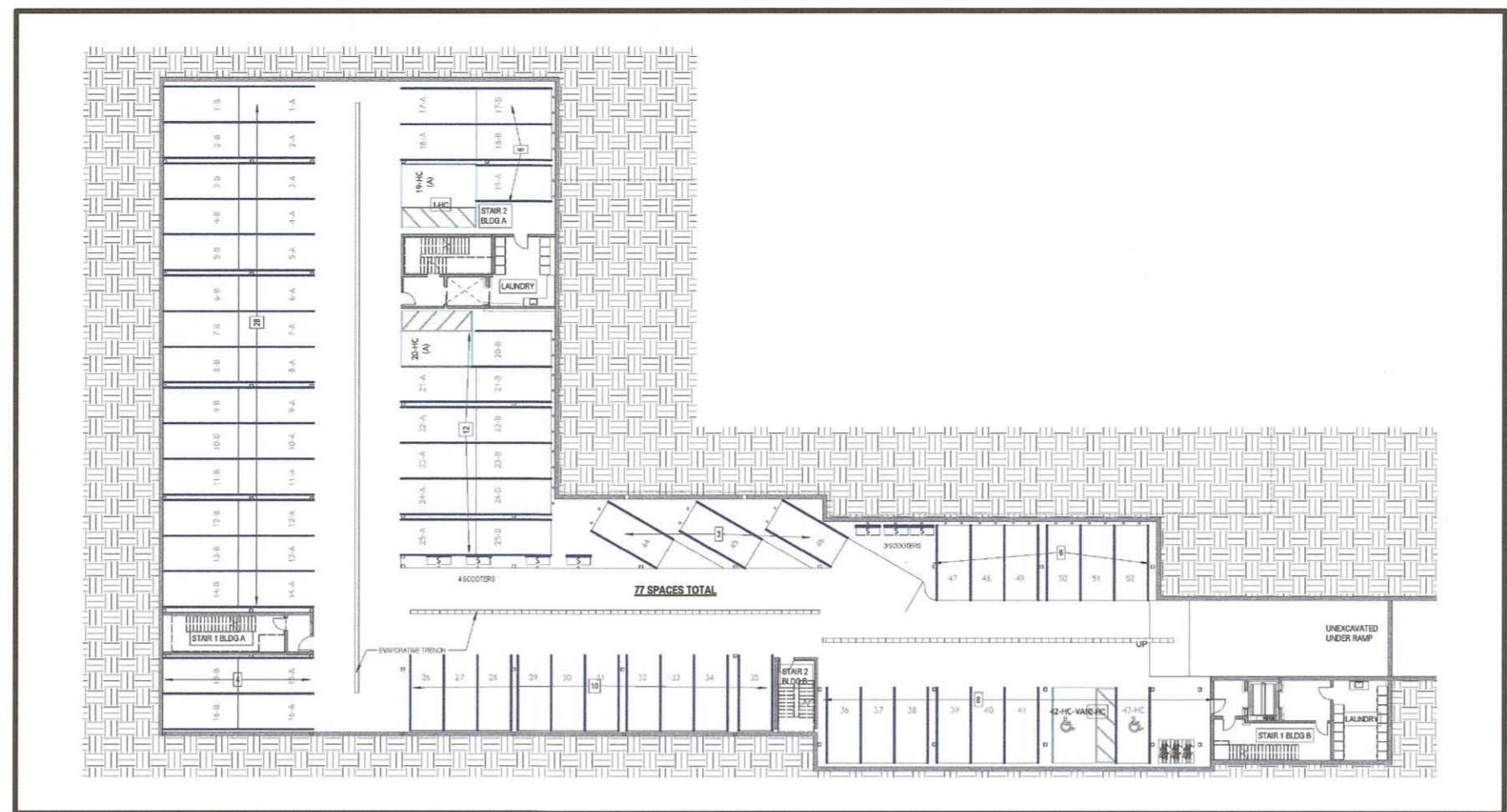

BASEMENT— 77 TOTAL SPACES

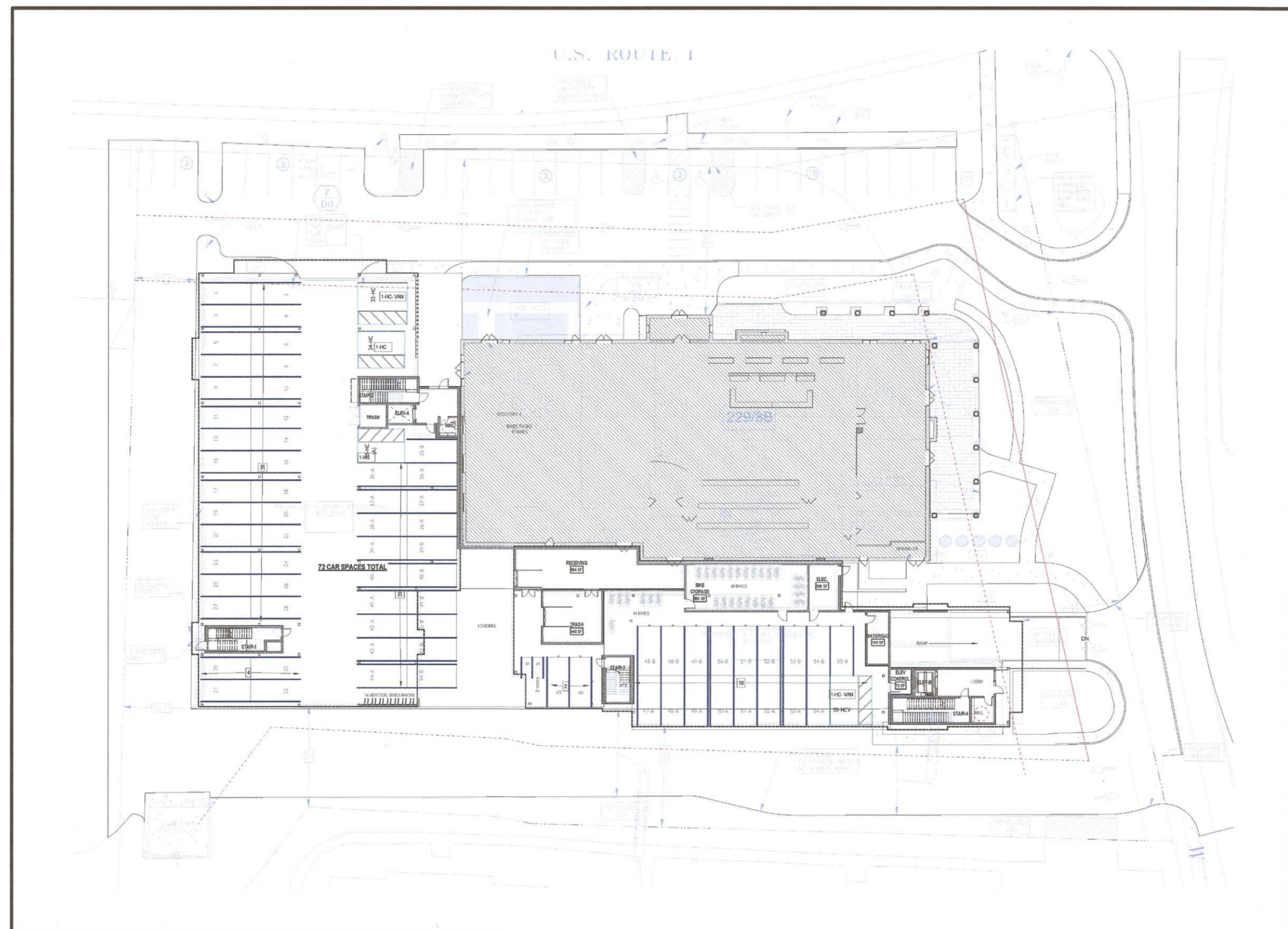

LEVEL 1— 74 TOTAL SPACES

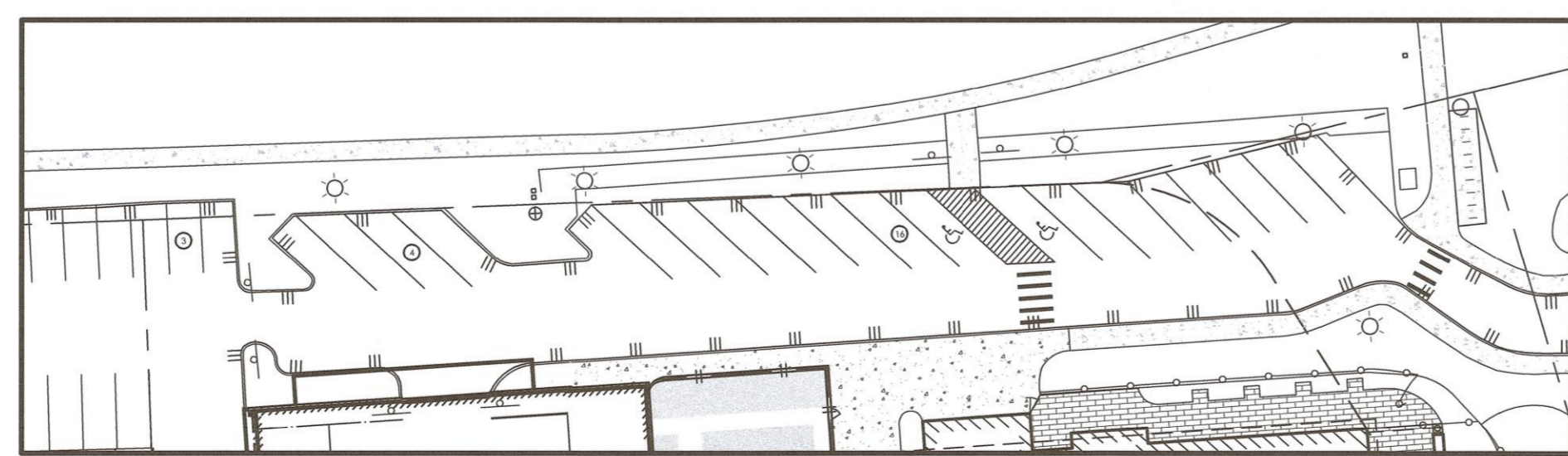

ALTERNATE PARKING LAYOUT

NOTE: THE ALTERNATE PARKING LAYOUT REDUCES SITE PARKING 7 SPACES (30-23)

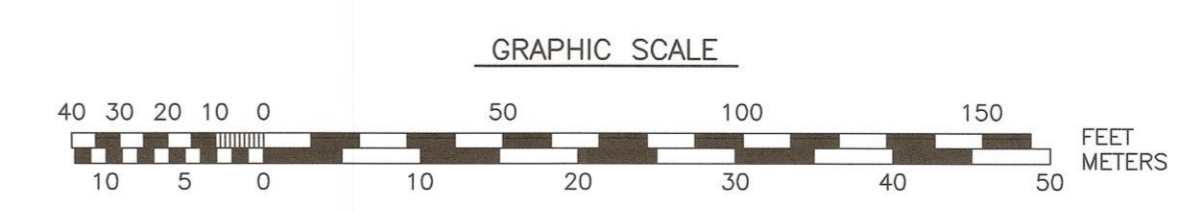

COMMERCIAL DEVELOPMENT
581 LAFAYETTE ROAD
PORTSMOUTH, N.H.

5	COMBINE PARKING PLANS, ALTERNATIVE	2/21/24
4	SEWER SIZE, NOTE 4	2/6/24
3	PARKING TABLES, PARKING LAYOUT	1/24/24
2	PARKING TABLES	12/19/23
1	ISSUED FOR APPROVAL	11/20/23
0	ISSUED FOR COMMENT	7/5/23

NO.	DESCRIPTION	DATE
-----	-------------	------

REVISIONS		

SCALE: 1"=40' JULY 2023

PARKING PLAN	C4
---------------------	-----------

P:\NH\010156-McKeeb-Properties\1397-03-Lafayette Rd., Portsmouth, NH\2023 Site Plan 1397-03\Plans & Specs\Site\Final Set Revised 2-22-2024\C4 - PARKING PLAN.dwg, 2/22/2024, 2:30:46 PM, 1397-03.dwg, 2/22/2024, 2:30:46 PM

DRAINAGE STRUCTURE SCHEDULE

STRUCTURE	PROP/EX	RIM	PIPE SIZE/TYPE	INVERT IN	INVERT OUT	DIRECTION
DMH 1	EX	22.3	15"	17.60	17.40	W
DMH 2	EX	22.3	15"	17.40	17.40	W
DMH 3	PROP		24"	17.69	17.44	E
CB 1	EX	21.46	24"	17.29	17.29	N
CB 2	EX	22.00	12"	18.00	17.95	N
CB 3	PROP	22.16	18"	17.80	17.70	N
CB 4	PROP	22.45	18"	17.90	17.90	S
CB 5	PROP	22.60	18"	18.02	18.02	S
CB 6	PROP	22.65	18"	18.09	21.06	S
CB 7	EX	24.16	12"	21.15	21.06	N
JELLYFISH FILTER	PROP	23.05	24"	17.41	17.31	S

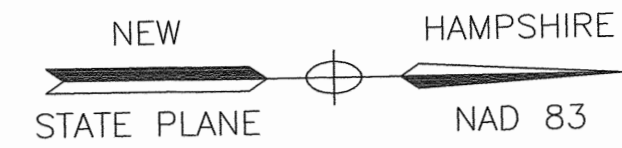

**LAFAYETTE ROAD
U.S. ROUTE 1**

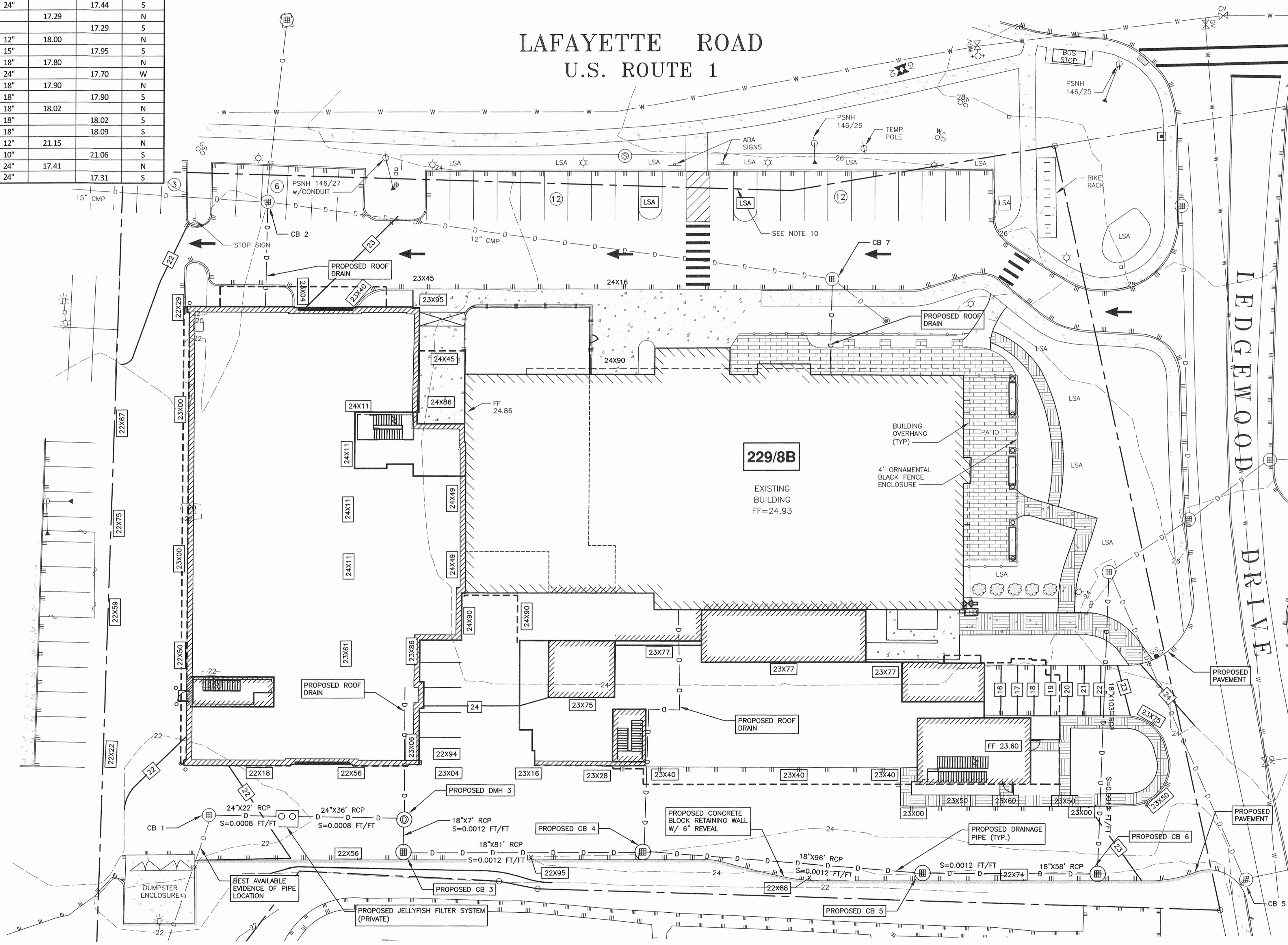

AMBIT ENGINEERING, INC.
A DIVISION OF HALEY WARD, INC.

200 Griffin Road, Unit 3
Portsmouth, NH 03801
603.430.9282

WWW.HALEYWARD.COM

- NOTES:**
- 1) THE CONTRACTOR SHALL NOTIFY DIG SAFE AT 1-888-DIG-SAFE (1-888-344-7233) AT LEAST 72 HOURS PRIOR TO COMMENCING ANY EXCAVATION ON PUBLIC OR PRIVATE PROPERTY WITHIN 100 FEET OF UNDERGROUND UTILITIES. THE EXCAVATOR IS RESPONSIBLE TO MAINTAIN MARKS. DIG SAFE TICKETS EXPIRE IN THIRTY DAYS.
 - 2) UNDERGROUND UTILITY LOCATIONS ARE BASED UPON BEST AVAILABLE EVIDENCE AND ARE NOT FIELD VERIFIED. LOCATING AND PROTECTING ANY ABOVEGROUND OR UNDERGROUND UTILITIES IS THE SOLE RESPONSIBILITY OF THE CONTRACTOR AND/OR THE OWNER. UTILITY CONFLICTS SHOULD BE REPORTED AT ONCE TO THE DESIGN ENGINEER.
 - 3) CONTRACTOR SHALL INSTALL AND MAINTAIN EROSION CONTROL MEASURES IN ACCORDANCE WITH THE "NEW HAMPSHIRE STORMWATER MANUAL, VOLUME 3, EROSION AND SEDIMENT CONTROLS DURING CONSTRUCTION. (NHDES DECEMBER 2008).

**COMMERCIAL DEVELOPMENT
581 LAFAYETTE ROAD
PORTSMOUTH, N.H.**

NO.	DESCRIPTION	DATE
3	BUILDING GRADES	2/21/24
2	GRADES	1/24/24
1	ISSUED FOR APPROVAL	11/20/23
0	ISSUED FOR COMMENT	2/7/23

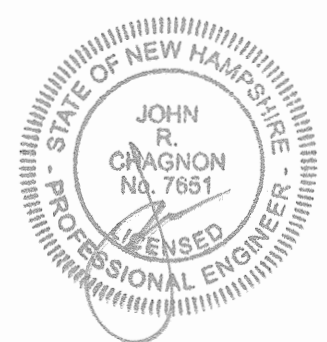

SCALE: 1"=20' JULY 2023

**GRADING DRAINAGE
EROSION CONTROL PLAN**

C6

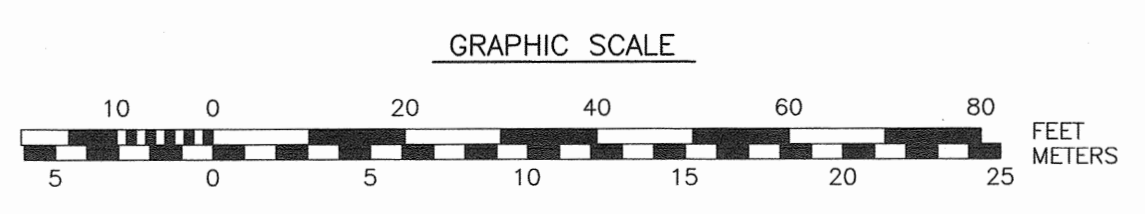

LAFAYETTE ROAD
U.S. ROUTE 1

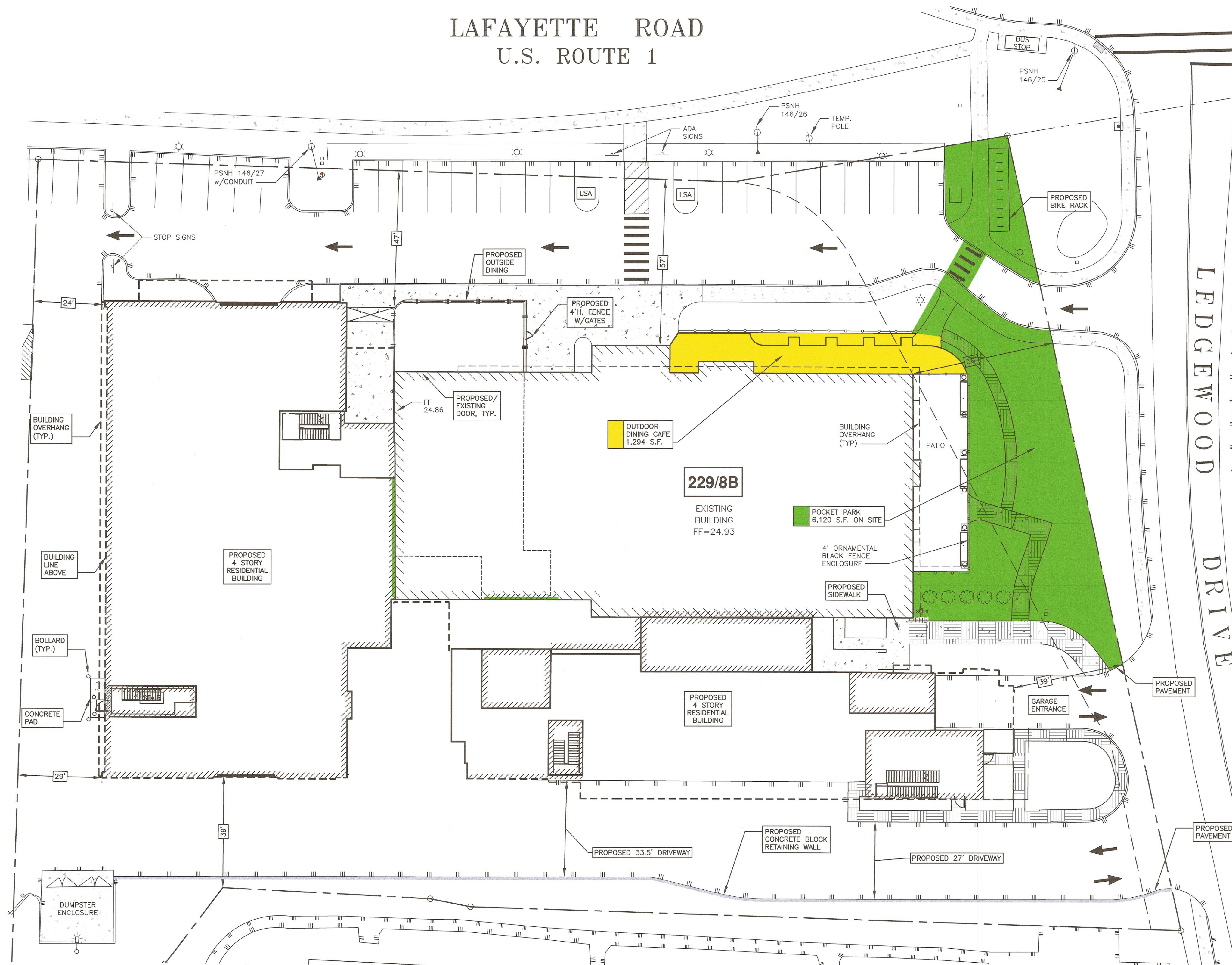

COMMUNITY SPACE ON-SITE
 POCKET PARK = 6,120 S.F.
 OUTDOOR DINING CAFE = 1,294 S.F.
 PROPOSED ON-SITE COMMUNITY SPACE 7,414 S.F.
 LOT AREA 98,124 S.F.
 COMMUNITY SPACE REQUIRED: 10%
 (PER SECTION 10.5B41.80.2)
 ON-SITE COMMUNITY SPACE PROVIDED: 7.6%
 COMMUNITY SPACE USES
 (PER SECTION 10.5B102)
 PROPOSED USES: OUTDOOR DINING CAFE
 POCKET PARK

NOTES:

- 1) PARCEL IS SHOWN ON THE CITY OF PORTSMOUTH ASSESSOR'S MAP 229 AS LOT 8B.
- 2) OWNERS OF RECORD:
ATLAS COMMONS, LLC
3 PLEASANT STREET, SUITE 400
PORTSMOUTH, NH 03801
6474/1538
- 3) THE PARCEL IS NOT IN A FLOOD HAZARD ZONE AS SHOWN ON FIRM PANEL 33015C0270F, EFFECTIVE JANUARY 29, 2021
- 4) EXISTING LOT AREA:
98,124 S.F.
2.2526 AC
- 5) PARCEL IS LOCATED IN THE GATEWAY NEIGHBORHOOD CORRIDOR (G1) DISTRICT.
- 6) DIMENSIONAL REQUIREMENTS:
SEE ZONING ORDINANCE SECTION 10.5B22.10
- 7) THE PURPOSE OF THIS PLAN IS TO SHOW THE ON-SITE COMMUNITY SPACE ON TAX MAP 229 LOT 8B.

COMMERCIAL DEVELOPMENT
581 LAFAYETTE ROAD
PORTSMOUTH, N.H.

NO.	DESCRIPTION	DATE
3	AREAS/TYPES	2/21/24
2	COMMUNITY SPACE TYPES	2/6/24
1	AREAS/TYPES	1/24/24
0	ISSUED FOR COMMENT	12/19/23

REVISIONS



SCALE: 1"=20' JULY 2023

ON-SITE COMMUNITY SPACE PLAN

C8

APPROVED BY THE PORTSMOUTH PLANNING BOARD

CHAIRMAN _____ DATE _____

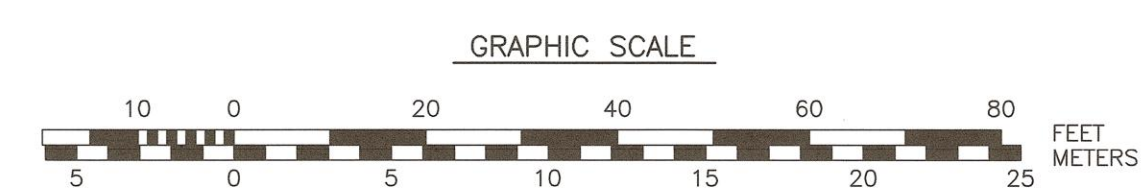

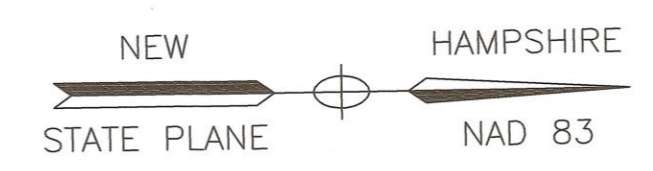

LAFAYETTE ROAD
U.S. ROUTE 1

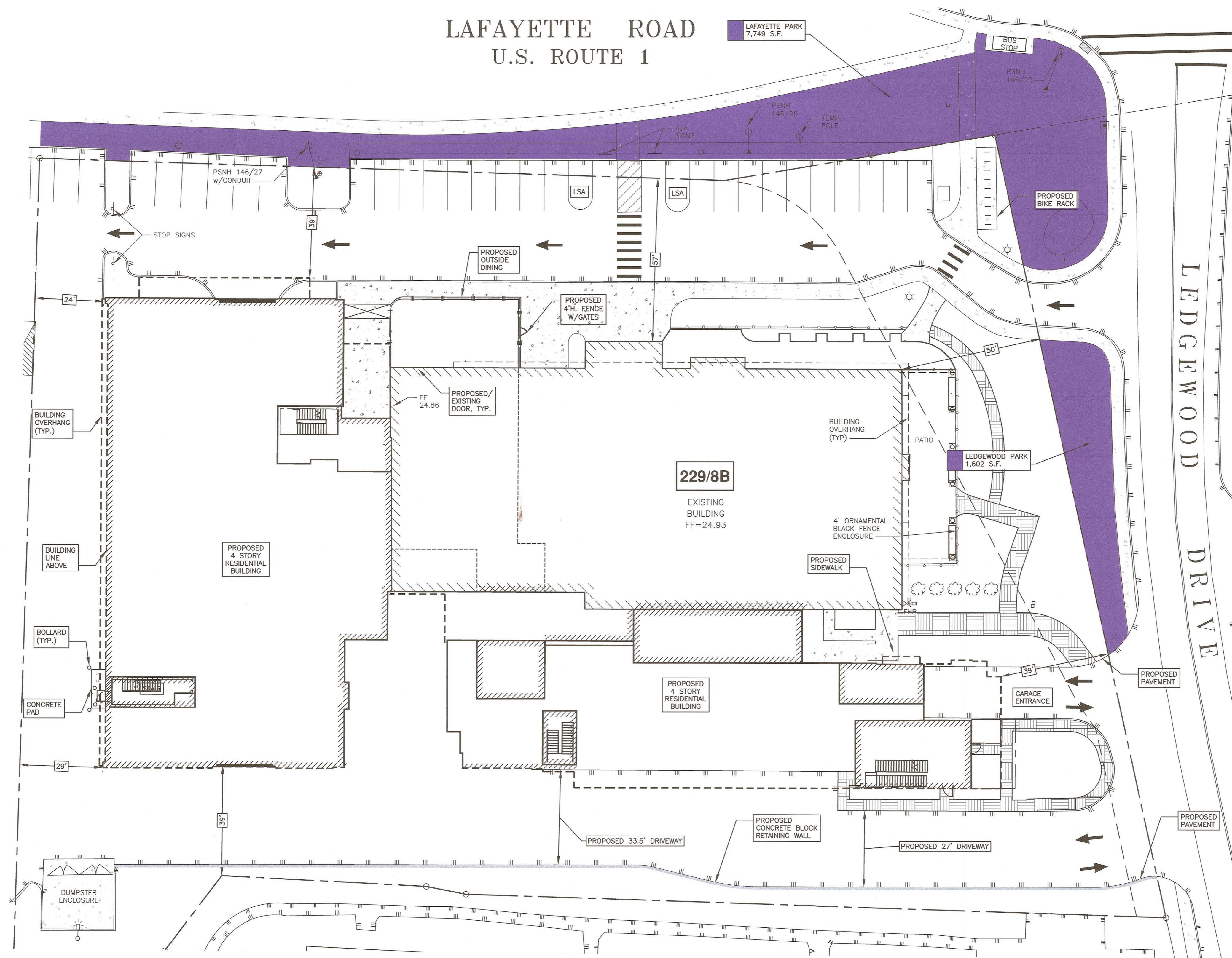

OFF-SITE LANDSCAPE MAINTENANCE AREA
LAFAYETTE PARK = 7,749 S.F.
LEDGEWOOD PARK = 1,602 S.F.
PROPOSED OFF-SITE MAINTENANCE AREA 9,351 S.F.

NOTES:

- 1) PARCEL IS SHOWN ON THE CITY OF PORTSMOUTH ASSESSOR'S MAP 229 AS LOT 8B.
- 2) OWNERS OF RECORD:
ATLAS COMMONS, LLC
3 PLEASANT STREET, SUITE 400
PORTSMOUTH, NH 03801
6474/1538
- 3) THE PARCEL IS NOT IN A FLOOD HAZARD ZONE AS SHOWN ON FIRM PANEL 3301500270F, EFFECTIVE JANUARY 29, 2021
- 4) EXISTING LOT AREA:
98,124 S.F.
2.2526 AC
- 5) PARCEL IS LOCATED IN THE GATEWAY NEIGHBORHOOD CORRIDOR (G1) DISTRICT.
- 6) DIMENSIONAL REQUIREMENTS:
SEE ZONING ORDINANCE SECTION 10.5B22.10
- 7) THE PURPOSE OF THIS PLAN IS TO SHOW THE OFF-SITE COMMUNITY SPACE TO BE MAINTAINED BY THE OWNER OF TAX MAP 229 LOT 8B.
- 8) SIGNAGE IDENTIFYING THE POCKET PARK AS PUBLIC SPACE TO BE PROVIDED.

COMMERCIAL DEVELOPMENT
581 LAFAYETTE ROAD
PORTSMOUTH, N.H.

1	TITLE	2/21/24
0	ISSUED FOR COMMENT	2/21/24
NO.	DESCRIPTION	DATE



SCALE: 1"=20' JULY 2023

OFF-SITE LANDSCAPE MAINTENANCE AREA **C8.1**

APPROVED BY THE PORTSMOUTH PLANNING BOARD

CHAIRMAN _____ DATE _____

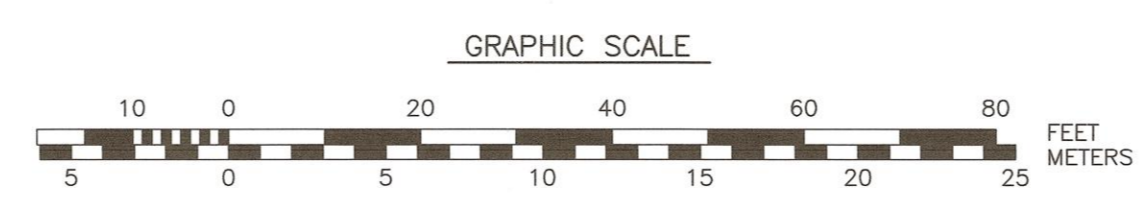

PUBLIC REALM

PUBLIC REALM IMPROVEMENT (PER SECTION 10.5B73.20.1)
 LINEAR STREET FRONTAGE OF SITE: 619 FT
 PROPOSED TRAIL NETWORK LENGTH: 622 FT

REQUIRED LENGTH: 619 FT
 PROVIDED LENGTH: 622 FT

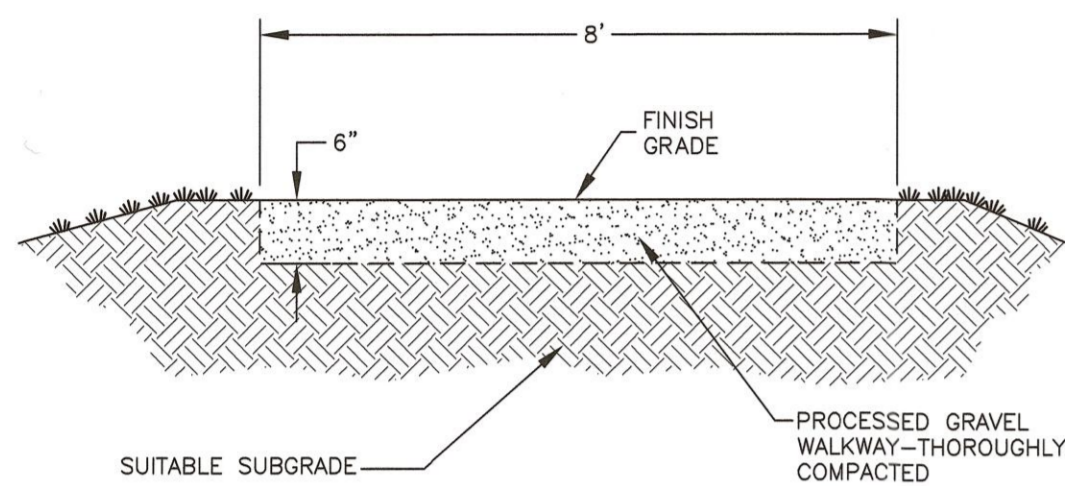

1 GRAVEL PATH
 NTS

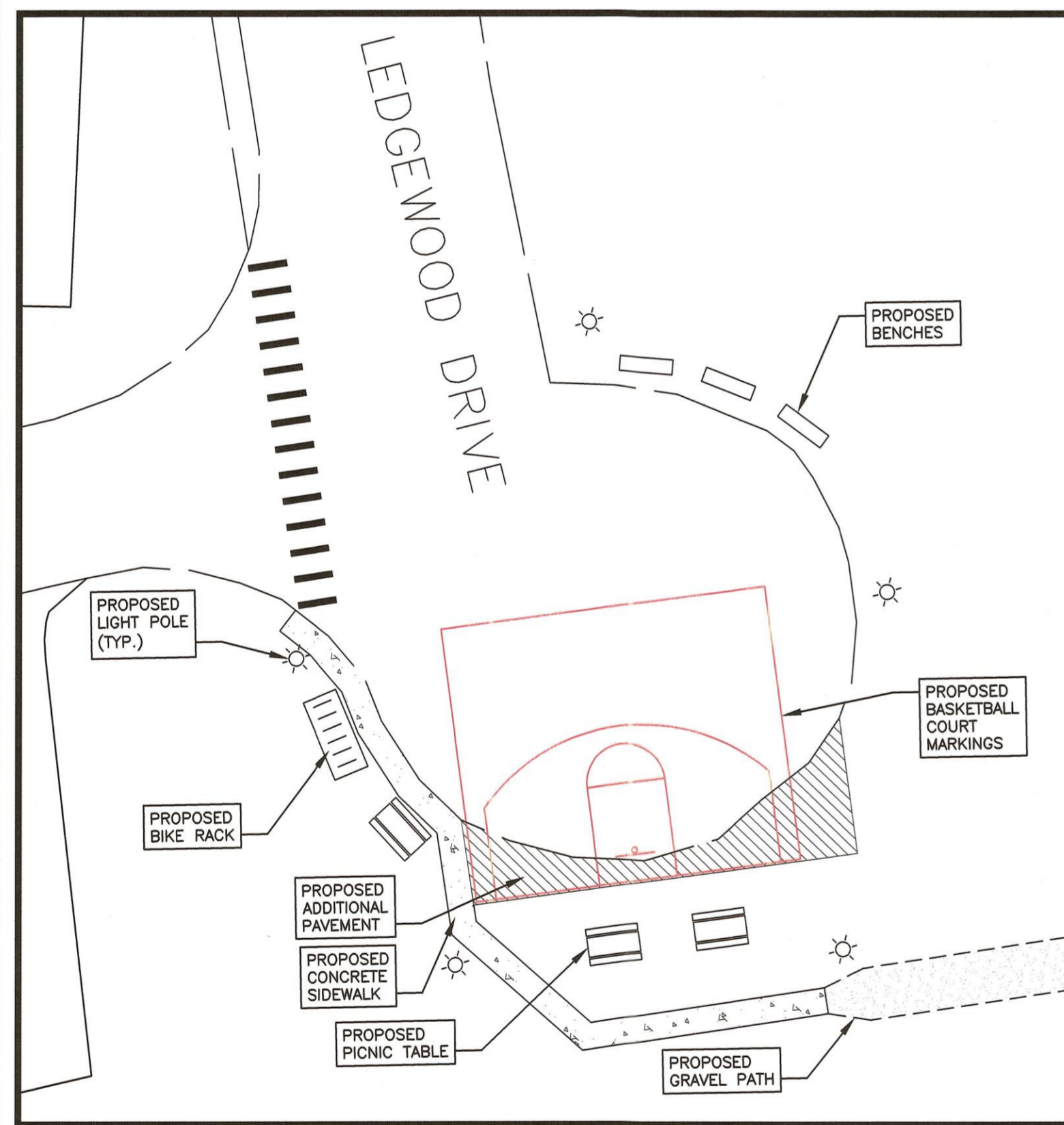

2 LEDGEWOOD IMPROVEMENTS
 NTS

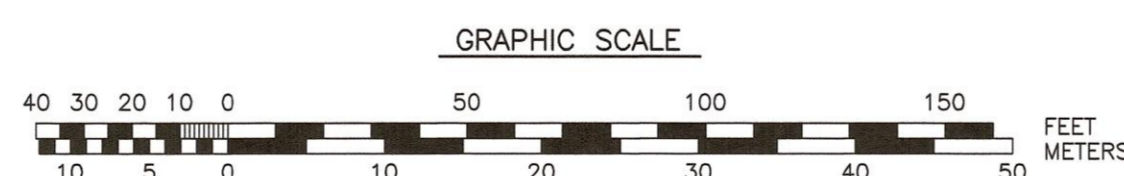
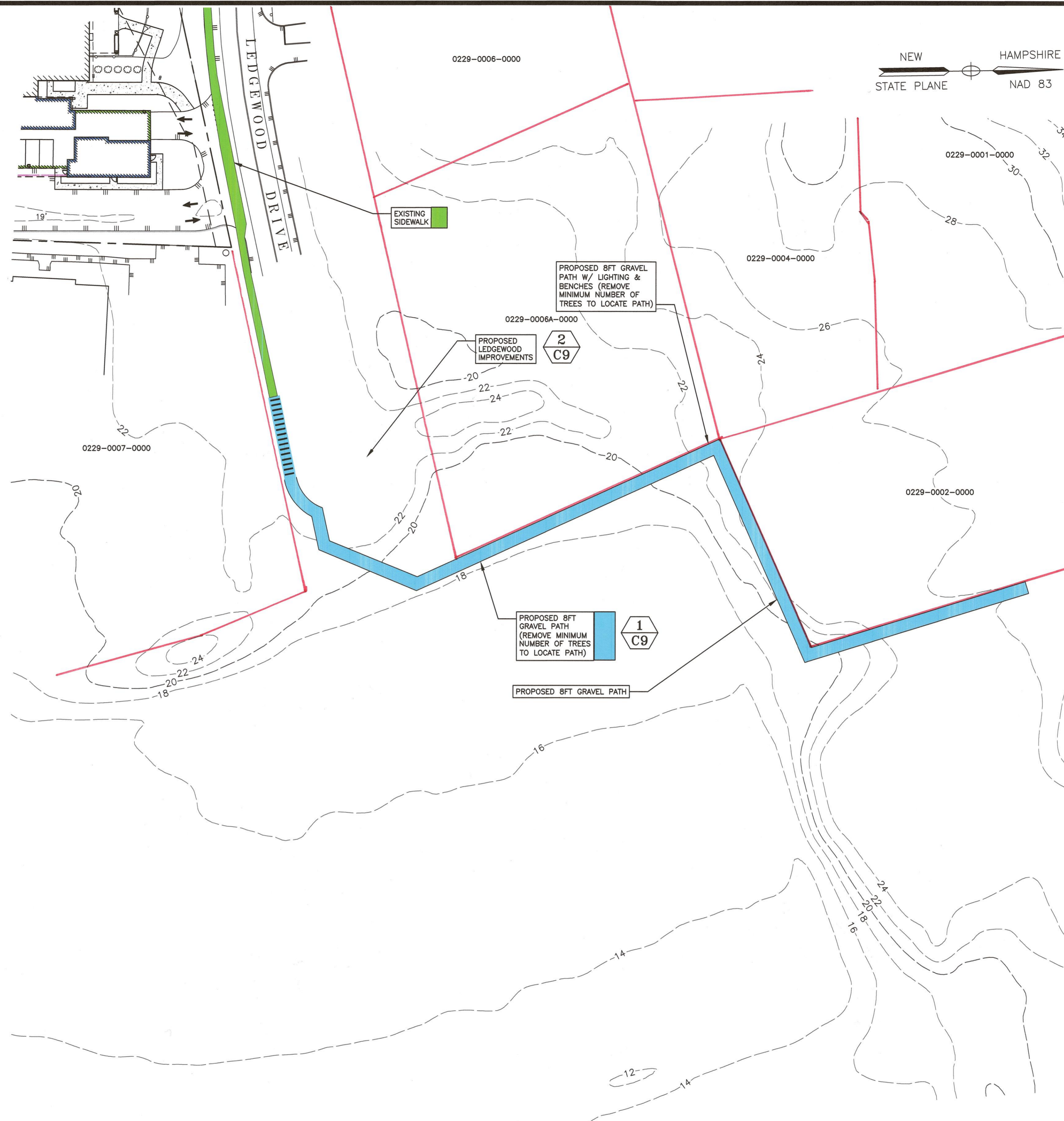
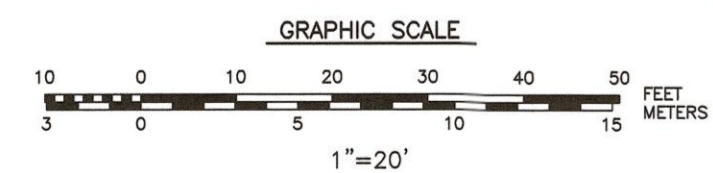

NEW HAMPSHIRE
 STATE PLANE NAD 83

NOTES:

- 1) PARCEL IS SHOWN ON THE CITY OF PORTSMOUTH ASSESSOR'S MAP 229 AS LOT 8B.
- 2) OWNERS OF RECORD:
 ATLAS COMMONS, LLC
 3 PLEASANT STREET, SUITE 400
 PORTSMOUTH, NH 03801
 6474/1538
- 3) THE PARCEL IS NOT IN A FLOOD HAZARD ZONE AS SHOWN ON FIRM PANEL 33015C0270E, EFFECTIVE MAY 17, 2005
- 4) EXISTING LOT AREA:
 98,124 S.F.
 2.2526 AC
- 5) PARCEL IS LOCATED IN THE GATEWAY NEIGHBORHOOD CORRIDOR (G1) DISTRICT.
- 6) DIMENSIONAL REQUIREMENTS:
 SEE ZONING ORDINANCE SECTION 10.5B22.10
- 7) THE PURPOSE OF THIS PLAN IS TO SHOW PUBLIC REALM IN ACCORDANCE WITH SECTION 10.5B7320.1 ON TAX MAP 229 LOT 8B.
- 8) PUBLIC REALM IMPROVEMENTS SHOWN HEREON ARE SUBJECT TO CITY OF PORTSMOUTH SCHOOL DEPARTMENT REVIEW AND APPROVAL. FINAL DESIGN & LOCATION TO BE DETERMINED.
- 9) TOPOGRAPHY FROM LIDAR.

COMMERCIAL DEVELOPMENT
581 LAFAYETTE ROAD
PORTSMOUTH, N.H.

NO.	DESCRIPTION	DATE
0	ISSUED FOR COMMENT	1/4/24

REVISIONS

SCALE: 1"=40' JANUARY 2024

PUBLIC REALM PLAN

C10

CONCEPT

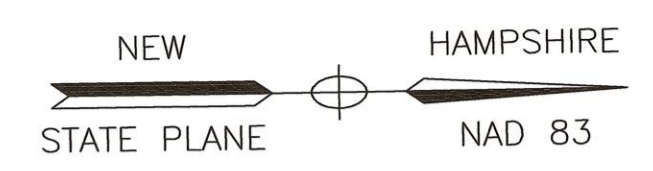

**LAFAYETTE ROAD
U.S. ROUTE 1**

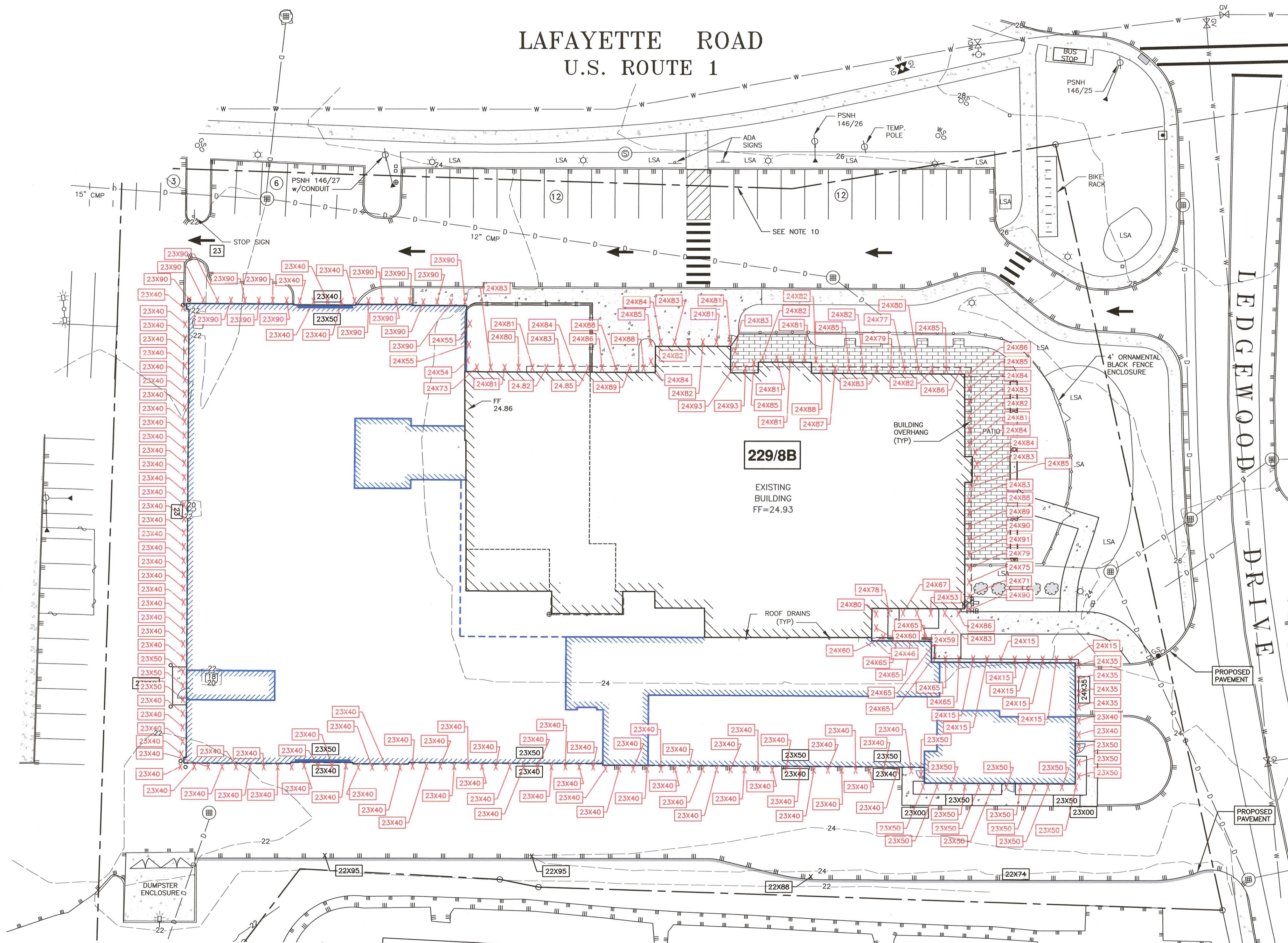

NOTES:

- 1) THE CONTRACTOR SHALL NOTIFY DIG SAFE AT 1-888-DIG-SAFE (1-888-344-7233) AT LEAST 72 HOURS PRIOR TO COMMENCING ANY EXCAVATION ON PUBLIC OR PRIVATE PROPERTY WITHIN 100 FEET OF UNDERGROUND UTILITIES. THE EXCAVATOR IS RESPONSIBLE TO MAINTAIN MARKS. DIG SAFE TICKETS EXPIRE IN THIRTY DAYS.
- 2) UNDERGROUND UTILITY LOCATIONS ARE BASED UPON BEST AVAILABLE EVIDENCE AND ARE NOT FIELD VERIFIED. LOCATING AND PROTECTING ANY ABOVEGROUND OR UNDERGROUND UTILITIES IS THE SOLE RESPONSIBILITY OF THE CONTRACTOR AND/OR THE OWNER. UTILITY CONFLICTS SHOULD BE REPORTED AT ONCE TO THE DESIGN ENGINEER.
- 3) CONTRACTOR SHALL INSTALL AND MAINTAIN EROSION CONTROL MEASURES IN ACCORDANCE WITH THE "NEW HAMPSHIRE STORMWATER MANUAL, VOLUME 3, EROSION AND SEDIMENT CONTROLS DURING CONSTRUCTION. (NHDES DECEMBER 2008).
- 4) VERTICAL DATUM IS NAVD88. BASIS OF VERTICAL DATUM IS REDUNDANT RTN GNSS OBSERVATIONS.

**COMMERCIAL
DEVELOPMENT
581 LAFAYETTE ROAD
PORTSMOUTH, N.H.**

0	ISSUED FOR COMMENT	1/11/24
NO.	DESCRIPTION	DATE



SCALE: 1"=20' DECEMBER 2023

PROPOSED AVERAGE GRADE PLANE **C12**

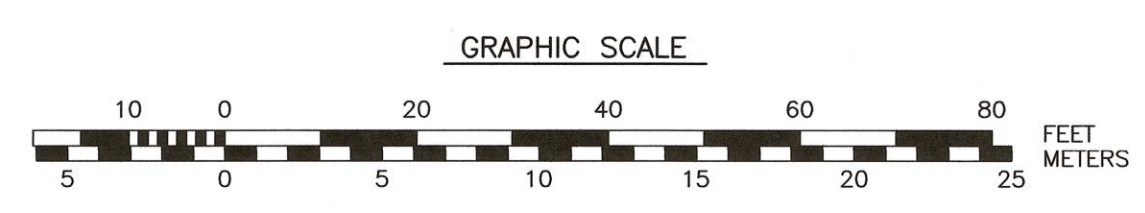

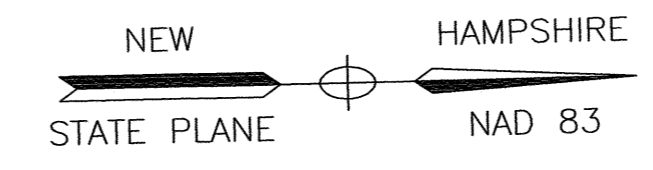

LAFAYETTE ROAD
U.S. ROUTE 1

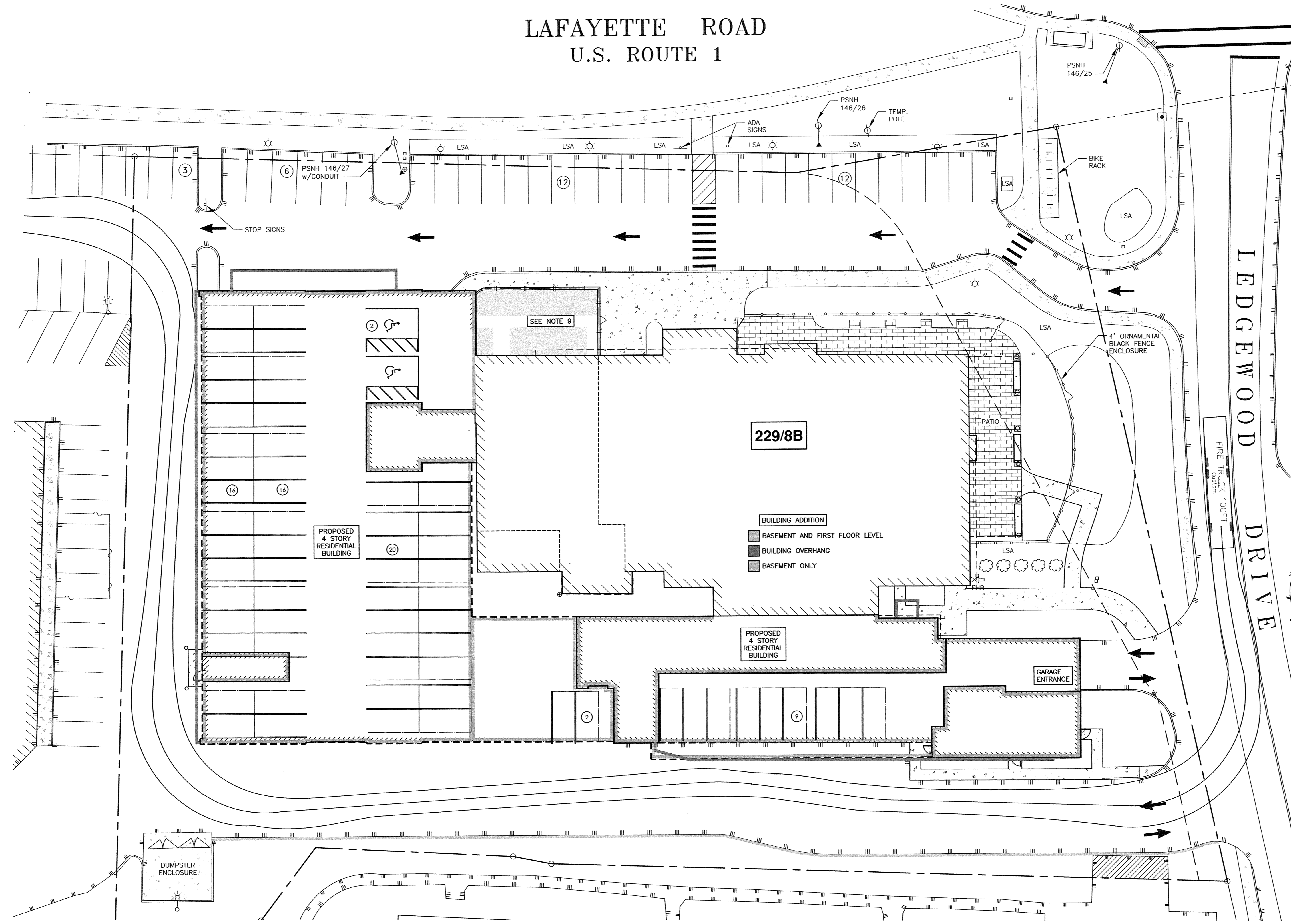

NOTES:

- 1) PARCEL IS SHOWN ON THE CITY OF PORTSMOUTH ASSESSOR'S MAP 229 AS LOT 8B.
- 2) OWNERS OF RECORD:
ATLAS COMMONS, LLC
3 PLEASANT STREET, SUITE 400
PORTSMOUTH, NH 03801
6474/1538
- 3) THE PARCEL IS NOT IN A FLOOD HAZARD ZONE AS SHOWN ON FIRM PANEL 33015C0270E, EFFECTIVE MAY 17, 2005
- 4) EXISTING LOT AREA:
98,124 S.F.
2.2526 AC
- 5) PARCEL IS LOCATED IN THE GATEWAY CORRIDOR (G1) DISTRICT.
- 6) DIMENSIONAL REQUIREMENTS:
SEE ZONING ORDINANCE SECTION 10.5B22.10
- 7) THE PURPOSE OF THIS PLAN IS TO SHOW GENERAL TURNING MOVEMENTS ON TAX MAP 229 LOT 8B.
- 8) DESIGN BASED ON ARCHITECTURAL PLAN BY ARCOVE ARCHITECTS DATED 8/22/23.
- 9) CONVERSION OF TUSCAN MARKETPLACE TO RESTAURANT (NORTHEASTERN THAI, LLC) APPROVED UNDER PERMIT: LU-22-254

COMMERCIAL DEVELOPMENT
581 LAFAYETTE ROAD
PORTSMOUTH, N.H.

NO.	DESCRIPTION	DATE
1	ISSUED FOR APPROVAL	1/24/24
0	ISSUED FOR COMMENT	8/31/23

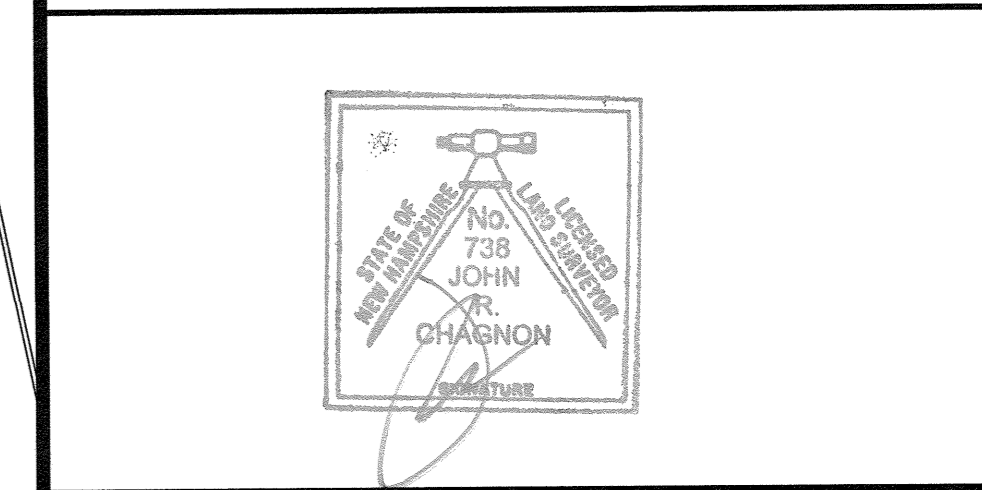

SCALE: 1"=20' JULY 2023

FIRE TRUCK TURNING PLAN **T1**

APPROVED BY THE PORTSMOUTH PLANNING BOARD

CHAIRMAN _____ DATE _____

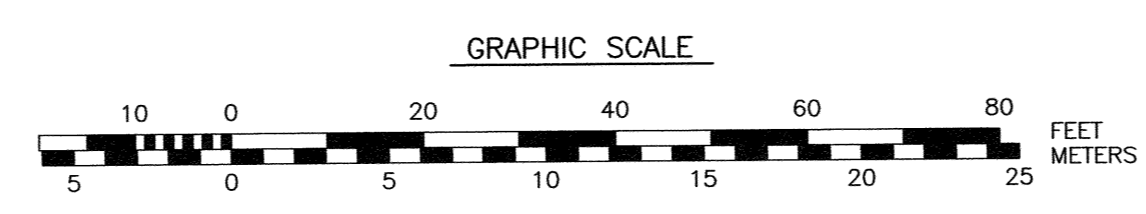

P:\NH\051516_Macys\1397.04_Lafayette_Rd_Portsmouth_Hampshire\1397.04_DISTING 2023.dwg 1/24/24 10:53:34 AM, Appointed: Peter Cerin 7/10/2023

LAFAYETTE ROAD
U.S. ROUTE 1

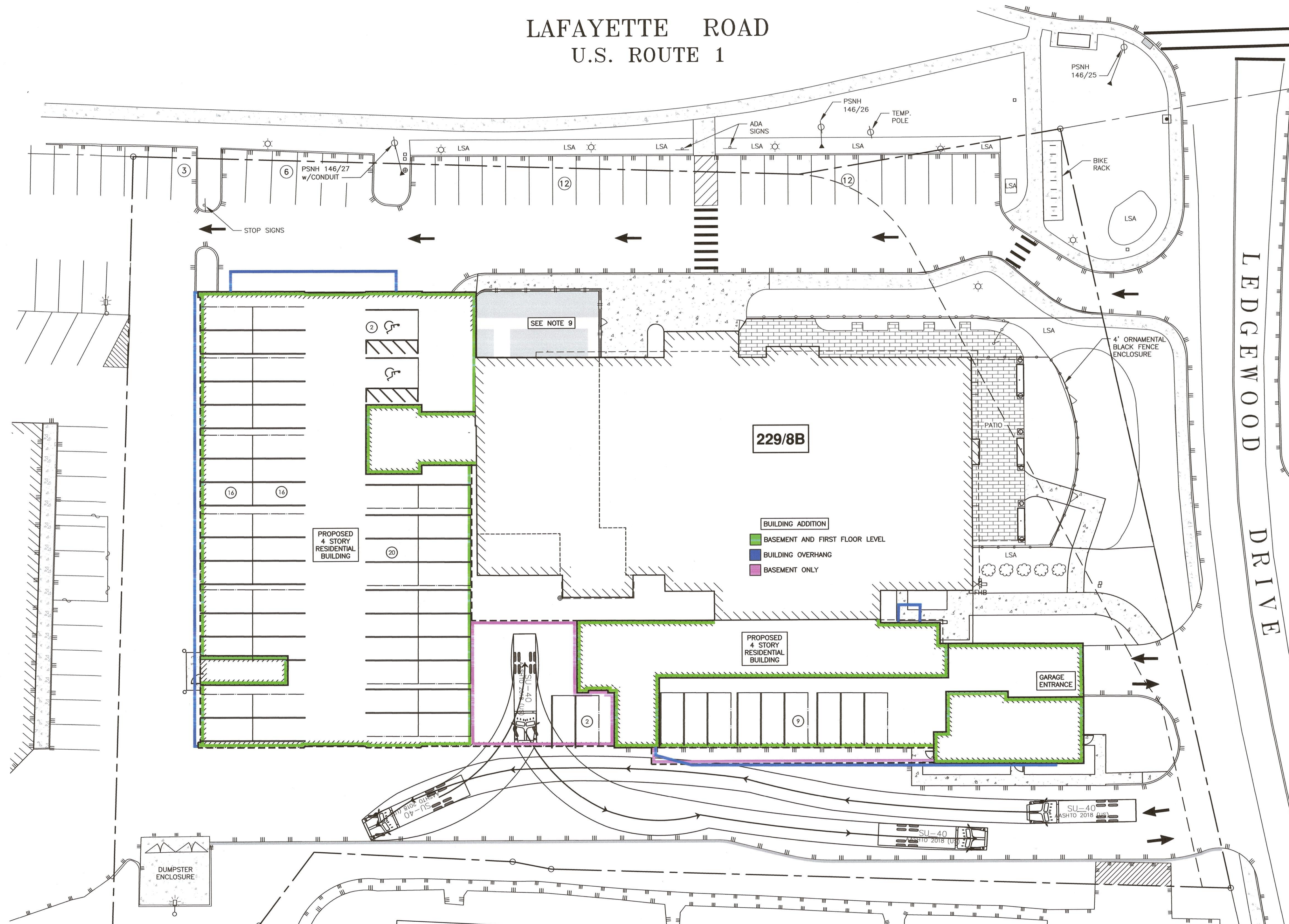

NOTES:

- 1) PARCEL IS SHOWN ON THE CITY OF PORTSMOUTH ASSESSOR'S MAP 229 AS LOT 8B.
- 2) OWNERS OF RECORD:
ATLAS COMMONS, LLC
3 PLEASANT STREET, SUITE 400
PORTSMOUTH, NH 03801
6474/1538
- 3) THE PARCEL IS NOT IN A FLOOD HAZARD ZONE AS SHOWN ON FIRM PANEL 33015C0270E, EFFECTIVE MAY 17, 2005
- 4) EXISTING LOT AREA:
98,124 S.F.
2.2526 AC
- 5) PARCEL IS LOCATED IN THE GATEWAY CORRIDOR (G1) DISTRICT.
- 6) DIMENSIONAL REQUIREMENTS:
SEE ZONING ORDINANCE SECTION 10.5B22.10
- 7) THE PURPOSE OF THIS PLAN IS TO SHOW GENERAL TURNING MOVEMENTS ON TAX MAP 229 LOT 8B.
- 8) DESIGN BASED ON ARCHITECTURAL PLAN BY ARCOVE ARCHITECTS DATED 8/22/23.
- 9) CONVERSION OF TUSCAN MARKETPLACE TO RESTAURANT (NORTHEASTERN THAI, LLC) APPROVED UNDER PERMIT: LU-22-254

COMMERCIAL DEVELOPMENT
581 LAFAYETTE ROAD
PORTSMOUTH, N.H.

NO.	DESCRIPTION	DATE
1	ISSUED FOR APPROVAL	1/24/24
0	ISSUED FOR COMMENT	8/31/23



SCALE: 1"=20' JULY 2023

DELIVERY TRUCK TURNING PLAN

T2

APPROVED BY THE PORTSMOUTH PLANNING BOARD

CHAIRMAN _____ DATE _____

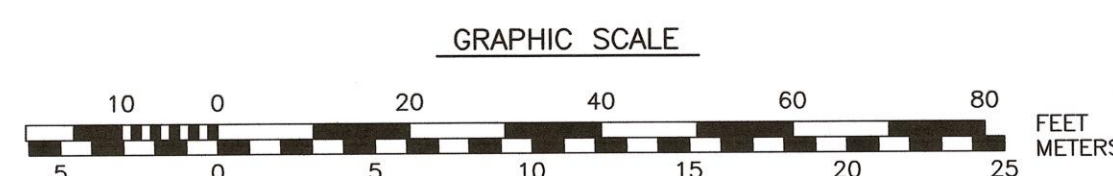

EROSION CONTROL NOTES

CONSTRUCTION SEQUENCE

- DO NOT BEGIN CONSTRUCTION UNTIL ALL LOCAL, STATE AND FEDERAL PERMITS HAVE BEEN APPLIED FOR AND RECEIVED.
- THE CONTRACTOR SHALL OBTAIN AN NPDES PHASE II STORMWATER PERMIT BEFORE BEGINNING CONSTRUCTION AND SHALL HAVE ON-SITE A STORMWATER POLLUTION PREVENTION PLAN (S.W.P.P.P.) AVAILABLE FOR INSPECTION BY THE PERMITTING AUTHORITY DURING THE CONSTRUCTION. THE CONTRACTOR SHALL BE RESPONSIBLE FOR CARRYING OUT THE S.W.P.P.P. AND INSPECTING AND MAINTAINING ALL BMP'S CALLED FOR BY THE PLAN. THE CONTRACTOR SHALL SUBMIT A NOTICE OF TERMINATION (N.O.T.) FORM TO THE REGIONAL EPA OFFICE WITHIN 30 DAYS OF FINAL STABILIZATION OF THE ENTIRE SITE OR TURNING OVER CONTROL OF THE SITE TO ANOTHER OPERATOR.
- INSTALL PERIMETER CONTROLS, I.E., SILT/SOXX AROUND THE LIMITS OF DISTURBANCE AND CATCH BASIN BASKETS AS NEEDED BEFORE ANY EARTH MOVING OPERATIONS.
- CONSTRUCT STABILIZED CONSTRUCTION ENTRANCE.
- CUT AND GRUB ALL TREES, SHRUBS, SAPLINGS, BRUSH, VINES AND REMOVE OTHER DEBRIS AND RUBBISH AS REQUIRED.
- DEMOLISH EXISTING WALKWAYS, PAVEMENT, AND UTILITIES AS INDICATED ON THE PLANS.
- REPLANT TREES OR MOVE TO STABLE LOCATION.
- BEGIN CONSTRUCTION OF ADDITIONS.
- LAYOUT AND INSTALL ALL BURIED UTILITIES AND SERVICES UP TO 10' OF THE PROPOSED BUILDING FOUNDATIONS. CAP AND MARK TERMINATIONS OR LOG SWING TIES.
- FINISH GRADE SITE, BACKFILL ROAD SUBBASE GRAVEL IN TWO, COMPACTED LIFTS. PROVIDE TEMPORARY EROSION PROTECTION IN THE FORM OF MULCHING, JUTE MESH OR DITCH DAMS.
- INSTALL RETAINING WALL.
- INSTALL DRAINAGE SYSTEM.
- PLACE BINDER LAYER OF PAVEMENT, THEN RAISE CATCH BASIN FRAMES TO FINAL GRADE. REINSTALL BASIN INLET PROTECTION.
- PLANT LANDSCAPING IN AREAS OUT OF WAY OF BUILDING CONSTRUCTION. PREPARE AND STABILIZE FINAL SITE GRADING BY ADDING TOPSOIL, SEED, MULCH AND FERTILIZER.
- AFTER BUILDINGS ARE COMPLETED, FINISH ALL REMAINING LANDSCAPED WORK.
- CONSTRUCT ASPHALT WEARING COURSE.
- REMOVE TRAPPED SEDIMENTS FROM COLLECTION DEVICES AS APPROPRIATE, AND THEN REMOVE TEMPORARY EROSION CONTROL MEASURES UPON COMPLETION OF FINAL STABILIZATION OF THE SITE.

GENERAL CONSTRUCTION NOTES

- THE EROSION CONTROL PROCEDURES SHALL CONFORM TO SECTION 645 OF THE "STANDARD SPECIFICATION FOR ROAD AND BRIDGE CONSTRUCTION" OF THE NHDOT, AND "STORM WATER MANAGEMENT AND EROSION AND SEDIMENT CONTROL HANDBOOK FOR URBAN AND DEVELOPING AREAS IN NEW HAMPSHIRE". THE PROJECT IS TO BE MANAGED IN A MANNER THAT MEETS THE REQUIREMENTS AND INTENT OF RSA 430:53 AND CHAPTER AGR 3800 RELATIVE TO INVASIVE SPECIES.
- DURING CONSTRUCTION AND THEREAFTER, EROSION CONTROL MEASURES ARE TO BE IMPLEMENTED AS NOTED. THE SMALLEST PRACTICAL AREA OF LAND SHOULD BE EXPOSED AT ANY ONE TIME DURING DEVELOPMENT. NO DISTURBED AREA SHALL BE LEFT UNSTABILIZED FOR MORE THAN 45 DAYS.
- ANY DISTURBED AREAS WHICH ARE TO BE LEFT TEMPORARILY, AND WHICH WILL BE REGRADED LATER DURING CONSTRUCTION SHALL BE MACHINE HAY MULCHED AND SEEDED WITH RYE GRASS TO PREVENT EROSION.
- DUST CONTROL: IF TEMPORARY STABILIZATION PRACTICES, SUCH AS TEMPORARY VEGETATION AND MULCHING, DO NOT ADEQUATELY REDUCE DUST GENERATION, APPLICATION OF WATER OR CALCIUM CHLORIDE SHALL BE APPLIED IN ACCORDANCE WITH BEST MANAGEMENT PRACTICES.
- SILT FENCES AND SILT/SOXX SHALL BE PERIODICALLY INSPECTED DURING THE LIFE OF THE PROJECT AND AFTER EACH STORM. ALL DAMAGED SILT FENCES AND SILT/SOXX SHALL BE REPAIRED. SEDIMENT DEPOSITS SHALL PERIODICALLY BE REMOVED AND DISPOSED IN A SECURED LOCATION.
- AVOID THE USE OF FUTURE OPEN SPACES (LOAM AND SEED AREAS) WHEREVER POSSIBLE DURING CONSTRUCTION. CONSTRUCTION TRAFFIC SHALL USE THE ROADBEDS OF FUTURE ACCESS DRIVES AND PARKING AREAS.
- ADDITIONAL TOPSOIL REQUIRED FOR THE ESTABLISHMENT OF VEGETATION SHALL BE STOCKPILED IN AMOUNTS NECESSARY TO COMPLETE FINISHED GRADING OF ALL EXPOSED AREAS--CONSTRUCT SILT FENCE OR SILT/SOXX AROUND TOPSOIL STOCKPILE.
- AREAS TO BE FILLED SHALL BE CLEARED, GRUBBED AND STRIPPED OF TOPSOIL TO REMOVE TREES, VEGETATION, ROOTS OR OTHER OBJECTIONABLE MATERIAL. STUMPS SHALL BE DISPOSED OF IN AN APPROVED FACILITY.
- ALL FILLS SHALL BE PLACED AND COMPACTED TO REDUCE EROSION, SLIPPAGE, SETTLEMENT, SUBSIDENCE OR OTHER RELATED PROBLEMS.
- ALL NON-STRUCTURAL, SITE-FILL SHALL BE PLACED AND COMPACTED TO 90% MODIFIED PROCTOR DENSITY IN LAYERS NOT EXCEEDING 18 INCHES IN THICKNESS UNLESS OTHERWISE NOTED.
- FROZEN MATERIAL OR SOFT, MUCKY OR HIGHLY COMPRESSIBLE MATERIAL, TRASH, WOODY DEBRIS, LEAVES, BRUSH OR ANY DELETERIOUS MATTER SHALL NOT BE INCORPORATED INTO FILLS.
- FILL MATERIAL SHALL NOT BE PLACED ON FROZEN FOUNDATION SUBGRADE.
- DURING CONSTRUCTION AND UNTIL ALL DEVELOPED AREAS ARE FULLY STABILIZED, ALL EROSION CONTROL MEASURES SHALL BE INSPECTED WEEKLY AND AFTER EACH ONE HALF INCH OF RAINFALL.
- THE CONTRACTOR SHALL MODIFY OR ADD EROSION CONTROL MEASURES AS NECESSARY TO ACCOMMODATE PROJECT CONSTRUCTION.
- ALL ROADWAYS AND PARKING AREAS SHALL BE STABILIZED WITHIN 72 HOURS OF ACHIEVING FINISHED GRADE. ALL CUT AND FILL SLOPES SHALL BE SEEDED/LOAMED WITHIN 72 HOURS OF ACHIEVING FINISHED GRADE.
- AN AREA SHALL BE CONSIDERED STABLE IF ONE OF THE FOLLOWING HAS OCCURRED:
 - BASE COURSE GRAVELS HAVE BEEN INSTALLED ON AREAS TO BE PAVED
 - A MINIMUM OF 85% VEGETATED GROWTH HAS BEEN ESTABLISHED
 - A MINIMUM OF 3 INCHES OF NON-EROSIVE MATERIAL SUCH AS STONE OR RIPRAP HAS BEEN INSTALLED
 - EROSION CONTROL BLANKETS HAVE BEEN INSTALLED

VEGETATIVE PRACTICE

FOR PERMANENT MEASURES AND PLANTINGS:

- LIMESTONE SHALL BE THOROUGHLY INCORPORATED INTO THE LOAM LAYER AT A RATE OF 2 TONS PER ACRE.
- FERTILIZER SHALL BE SPREAD ON THE TOP LAYER OF LOAM AND WORKED INTO THE SURFACE. FERTILIZER APPLICATION RATE SHALL BE 500 POUNDS PER ACRE OF 10-20-20 FERTILIZER.
- SEED SHALL BE SOWN AT THE RATES SHOWN IN THE TABLE BELOW. IMMEDIATELY BEFORE SEEDING,

THE SOIL SHALL BE LIGHTLY RAKED. ONE HALF THE SEED SHALL BE SOWN IN ONE DIRECTION AND THE OTHER HALF AT RIGHT ANGLES TO THE ORIGINAL DIRECTION. IT SHALL BE LIGHTLY RAKED INTO THE SOIL TO A DEPTH NOT OVER 1/4 INCH AND ROLLED WITH A HAND ROLLER WEIGHING NOT OVER 100 POUNDS PER LINEAR FOOT OF WIDTH. HAY MULCH SHALL BE APPLIED IMMEDIATELY AFTER SEEDING AT A RATE OF 1.5 TO 2 TONS PER ACRE, AND SHALL BE HELD IN PLACE USING APPROPRIATE TECHNIQUES FROM THE EROSION AND SEDIMENT CONTROL HANDBOOK.

THE SURFACE SHALL BE WATERED AND KEPT MOIST WITH A FINE SPRAY AS REQUIRED, WITHOUT WASHING AWAY THE SOIL, UNTIL THE GRASS IS WELL ESTABLISHED. ANY AREAS WHICH ARE NOT SATISFACTORILY COVERED SHALL BE RESEED, AND ALL NOXIOUS WEEDS REMOVED.

A GRASS SEED MIXTURE CONTAINING THE FOLLOWING SEED REQUIREMENTS SHALL BE:

GENERAL COVER	PROPORTION	SEEDING RATE
CREeping RED FESCUE	50%	100 LBS/ACRE
KENTUCKY BLUEGRASS	50%	
SLOPE SEED (USED ON ALL SLOPES GREATER THAN OR EQUAL TO 3:1)		
CREeping RED FESCUE	42%	
TALL FESCUE	42%	48 LBS/ACRE
BIRDSFOOT TREFLOIL	16%	

IN NO CASE SHALL THE WEED CONTENT EXCEED ONE PERCENT BY WEIGHT. ALL SEED SHALL COMPLY WITH APPLICABLE STATE AND FEDERAL SEED LAWS.

FOR TEMPORARY PROTECTION OF DISTURBED AREAS:
 MULCHING AND SEEDING SHALL BE APPLIED AT THE FOLLOWING RATES:
 PERENNIAL RYE: 0.7 LBS./1,000 S.F.
 MULCH: 1.5 TONS/ACRE

MAINTENANCE AND PROTECTION

- THE CONTRACTOR SHALL MAINTAIN ALL LOAM & SEED AREAS UNTIL FINAL ACCEPTANCE AT THE COMPLETION OF THE CONTRACT. MAINTENANCE SHALL INCLUDE WATERING, WEEDING, REMOVAL OF STONES AND OTHER FOREIGN OBJECTS OVER 1/2 INCHES IN DIAMETER WHICH MAY APPEAR AND THE FIRST TWO (2) CUTTINGS OF GRASS NO CLOSER THEN TEN (10) DAYS APART. THE FIRST CUTTING SHALL BE ACCOMPLISHED WHEN THE GRASS IS FROM 2 1/2 TO 3 INCHES HIGH. ALL BARE AND DEAD SPOTS WHICH BECOME APPARENT SHALL BE PROPERLY PREPARED, LIMED AND FERTILIZED, AND RESEED BY THE CONTRACTOR AT HIS EXPENSE AS MANY TIMES AS NECESSARY TO SECURE GOOD GROWTH. THE ENTIRE AREA SHALL BE MAINTAINED, WATERED AND CUT UNTIL ACCEPTANCE OF THE LAWN BY THE OWNER'S REPRESENTATIVE.
- THE CONTRACTOR SHALL TAKE WHATEVER MEASURES ARE NECESSARY TO PROTECT THE GRASS WHILE IT IS DEVELOPING.
- TO BE ACCEPTABLE, SEEDED AREAS SHALL CONSIST OF A UNIFORM STAND OF AT LEAST 90 PERCENT ESTABLISHED PERMANENT GRASS SPECIES, WITH UNIFORM COUNT OF AT LEAST 100 PLANTS PER SQUARE FOOT.
- SEEDED AREAS WILL BE FERTILIZED AND RESEED AS NECESSARY TO INSURE VEGETATIVE ESTABLISHMENT.
- THE SWALES WILL BE CHECKED WEEKLY AND REPAIRED WHEN NECESSARY UNTIL ADEQUATE VEGETATION IS ESTABLISHED.
- THE SILT FENCE OR SILT/SOXX BARRIER SHALL BE CHECKED AFTER EACH RAINFALL AND AT LEAST DAILY DURING PROLONGED RAINFALL.
- SILT FENCING AND SILT/SOXX SHALL BE REMOVED ONCE VEGETATION IS ESTABLISHED, AND DISTURBED AREAS RESULTING FROM SILT FENCE AND SILT/SOXX REMOVAL SHALL BE PERMANENTLY SEEDED.

WINTER NOTES

- ALL PROPOSED VEGETATED AREAS WHICH DO NOT EXHIBIT A MINIMUM OF 85% VEGETATIVE GROWTH BY OCTOBER 15TH, OR WHICH ARE DISTURBED AFTER OCTOBER 15TH, SHALL BE STABILIZED BY SEEDING AND INSTALLING EROSION CONTROL BLANKETS ON SLOPES GREATER THAN 3:1, AND SEEDING AND PLACING 3 TO 4 TONS OF MULCH PER ACRE, SECURED WITH ANCHORED NETTING, ELSEWHERE. THE INSTALLATION OF EROSION CONTROL BLANKETS OR MULCH AND NETTING SHALL NOT OCCUR OVER ACCUMULATED SNOW OR ON FROZEN GROUND AND SHALL BE COMPLETED IN ADVANCE OF THAW OR SPRING MELT EVENTS.
- ALL DITCHES OR SWALES WHICH DO NOT EXHIBIT A MINIMUM OF 85% VEGETATIVE GROWTH BY OCTOBER 15TH, OR WHICH ARE DISTURBED AFTER OCTOBER 15TH, SHALL BE STABILIZED TEMPORARILY WITH STONE OR EROSION CONTROL BLANKETS APPROPRIATE FOR THE DESIGN FLOW CONDITIONS.
- AFTER NOVEMBER 15TH, INCOMPLETE ROAD OR PARKING SURFACES, WHERE WORK HAS STOPPED FOR THE WINTER SEASON, SHALL BE PROTECTED WITH A MINIMUM OF 3 INCHES OF CRUSHED GRAVEL PER NHDOT ITEM 304.3.

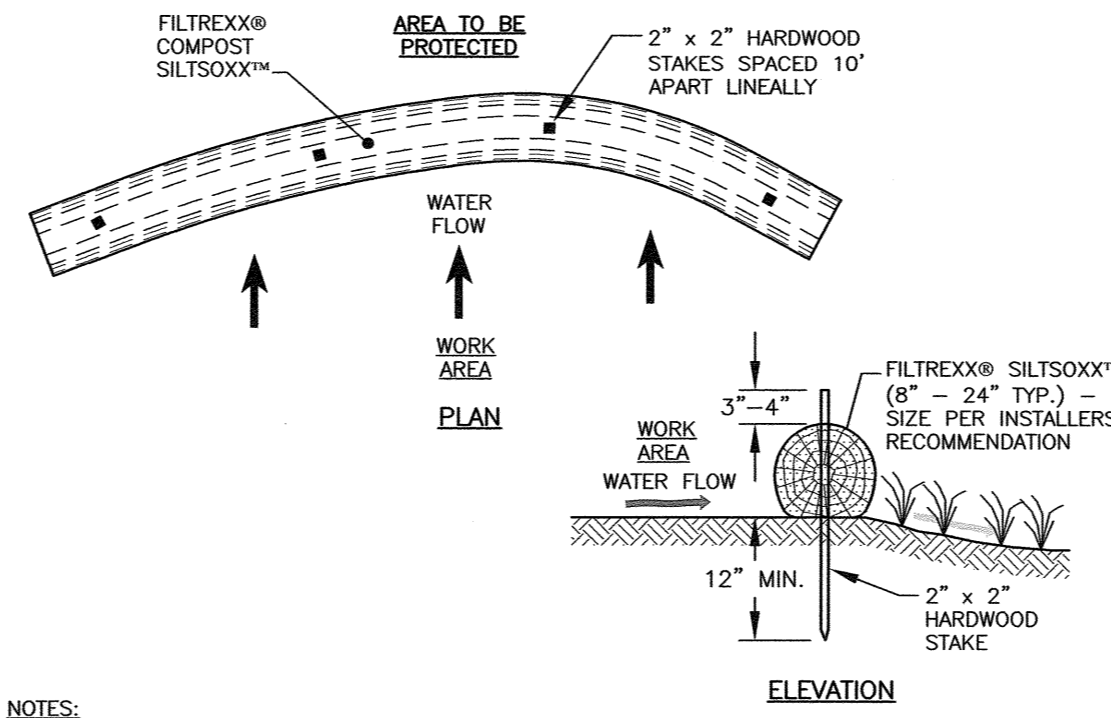

- NOTES:**
- ALL MATERIAL TO MEET FILTRIXX SPECIFICATIONS.
 - FILTRIXX SYSTEM SHALL BE INSTALLED BY A CERTIFIED FILTRIXX INSTALLER.
 - THE CONTRACTOR SHALL MAINTAIN THE COMPOST FILTRATION SYSTEM IN A FUNCTIONAL CONDITION AT ALL TIMES. IT WILL BE ROUTINELY INSPECTED AND REPAIRED WHEN REQUIRED.
 - SILT/SOXX DEPICTED IS FOR MINIMUM SLOPES, GREATER SLOPES MAY REQUIRE ADDITIONAL PLACEMENTS.
 - THE COMPOST FILTER MATERIAL WILL BE DISPENSED ON SITE WHEN NO LONGER REQUIRED, AS DETERMINED BY THE ENGINEER.

A C6 FILTRIXX® SILT/SOXX™ FILTRATION SYSTEM NTS

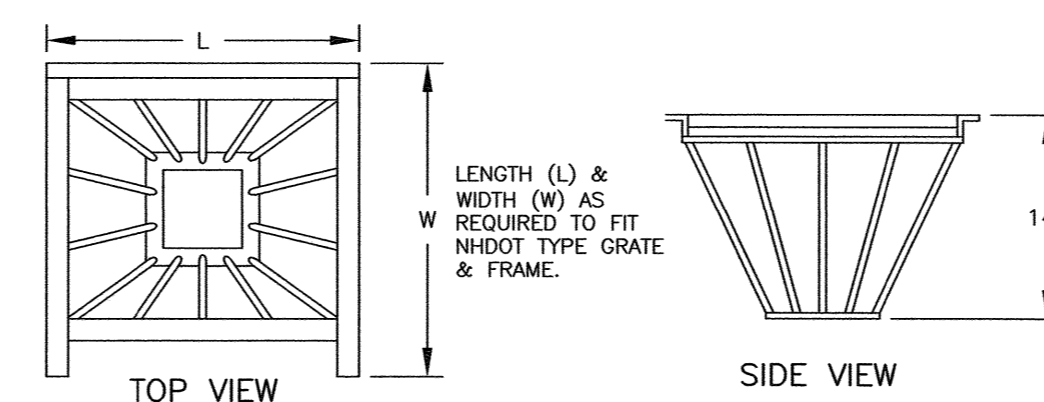

- INLET BASKETS SHALL BE INSTALLED IMMEDIATELY AFTER CATCH BASIN CONSTRUCTION IS COMPLETE AND SHALL REMAIN IN PLACE AND BE MAINTAINED UNTIL PAVEMENT BINDER COURSE IS COMPLETE.
- FILTER FABRIC SHALL BE PUSHED DOWN AND FORMED TO THE SHAPE OF THE BASKET. THE SHEET OF FABRIC SHALL BE LARGE ENOUGH TO BE SUPPORTED BY THE BASKET FRAME WHEN HOLDING SEDIMENT AND, SHALL EXTEND AT LEAST 6" PAST THE FRAME. THE INLET GRATE SHALL BE PLACED OVER THE BASKET/FRAME AND WILL SERVE AS THE FABRIC ANCHOR.
- THE FILTER FABRIC SHALL BE A GEOTEXTILE FABRIC: POLYESTER, POLYPROPYLENE, STABILIZED NYLON, POLYETHYLENE, OR POLYVINYLIDENE CHLORIDE MEETING THE FOLLOWING SPECIFICATIONS:
 - RAB STRENGTH: 45 LB. MIN. IN ANY PRINCIPAL DIRECTION (ASTM D1682)
 - MULLEN BURST STRENGTH: MIN. 60 psi (ASTM D774)
- THE FABRIC SHALL HAVE AN OPENING NO GREATER THAN A NUMBER 20 U.S. STANDARD SIEVE AND A MINIMUM PERMEABILITY OF 120 gpm/ft. (MULTIPLY THE PERMITTIVITY IN SEC.-1 FROM ASTM 54491-85 CONSTANT HEAD TEST USING THE CONVERSION FACTOR OF 74.)
- THE INLET BASKET SHALL BE INSPECTED WITHIN 24 HOURS AFTER EACH RAINFALL OR DAILY DURING EXTENDED PERIODS OF PRECIPITATION. REPAIRS SHALL BE MADE IMMEDIATELY, AS NECESSARY, TO PREVENT PARTICLES FROM REACHING THE DRAINAGE SYSTEM AND/OR CAUSING SURFACE FLOODING.
- SEDIMENT DEPOSITS SHALL BE REMOVED AFTER EACH STORM EVENT, OR MORE OFTEN IF THE FABRIC BECOMES CLOGGED.

B C6 CATCH BASIN INLET BASKET NTS

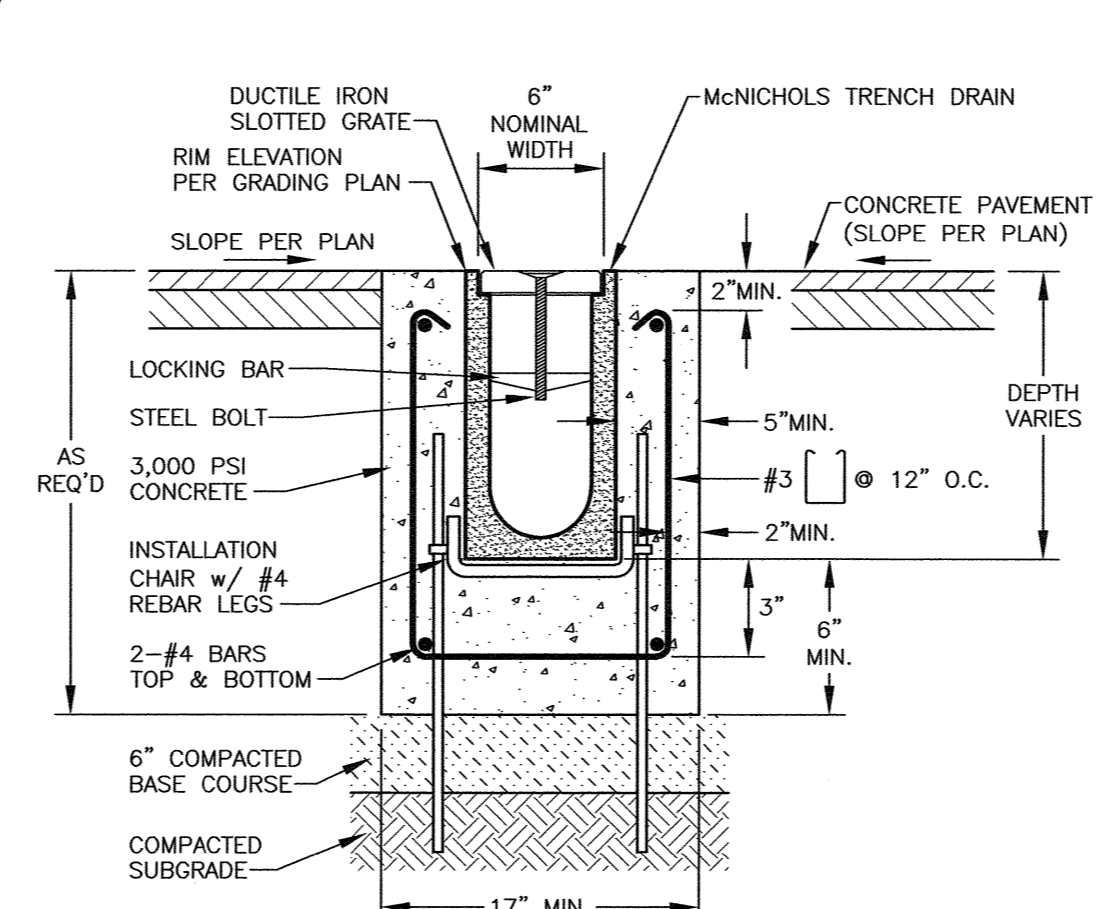

D C4 EVAPORATIVE TRENCH DRAIN DETAIL IN GARAGE NTS SECTION

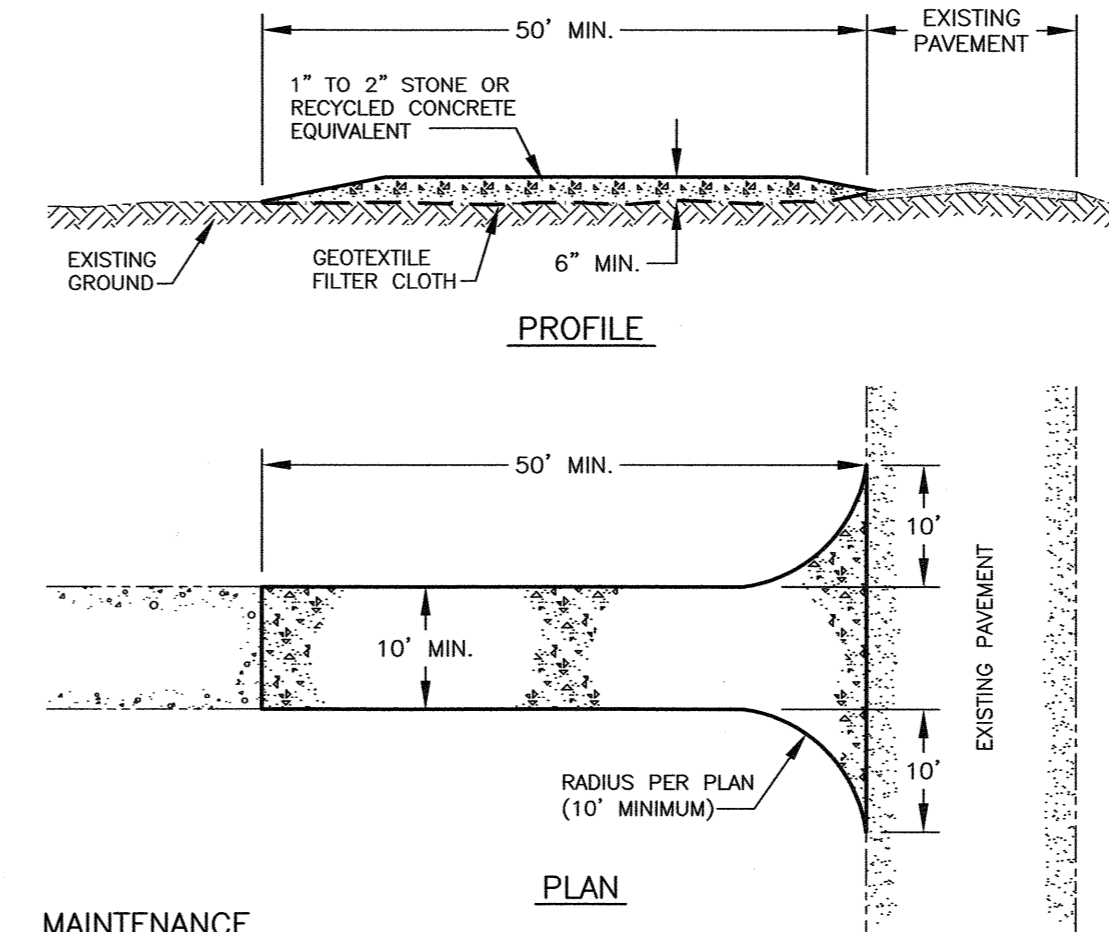

- MAINTENANCE**
- MUD AND SOIL PARTICLES WILL EVENTUALLY CLOG THE VOIDS IN THE GRAVEL AND THE EFFECTIVENESS OF THE GRAVEL PAD WILL NOT BE SATISFACTORY. WHEN THIS OCCURS, THE PAD SHOULD BE TOP DRESSED WITH NEW STONE. COMPLETE REPLACEMENT OF THE PAD MAY BE NECESSARY WHEN THE PAD BECOMES COMPLETELY CLOGGED.
 - IF WASHING FACILITIES ARE USED, THE SEDIMENT TRAPS SHOULD BE CLEANED OUT AS OFTEN AS NECESSARY TO ASSURE THAT ADEQUATE TRAPPING EFFICIENCY AND STORAGE VOLUME IS AVAILABLE. VEGETATIVE FILTER STRIPS SHOULD BE MAINTAINED TO INSURE A VIGOROUS STAND OF VEGETATION AT ALL TIMES.

CONSTRUCTION SPECIFICATIONS

- STONE FOR A STABILIZED CONSTRUCTION ENTRANCE SHALL BE 1 TO 2 INCH STONE, RECLAIMED STONE, OR RECYCLED CONCRETE EQUIVALENT.
- THE LENGTH OF THE STABILIZED ENTRANCE SHALL NOT BE LESS THAN 50 FEET, EXCEPT FOR A SINGLE RESIDENTIAL LOT WHERE A 30 FOOT MINIMUM LENGTH WOULD APPLY.
- THE THICKNESS OF THE STONE FOR THE STABILIZED ENTRANCE SHALL NOT BE LESS THAN 6 INCHES.
- THE WIDTH OF THE ENTRANCE SHALL NOT BE LESS THAN THE FULL WIDTH OF THE ENTRANCE WHERE INGRESS OR EGRESS OCCURS OR 10 FEET, WHICHEVER IS GREATER.
- GEOTEXTILE FILTER CLOTH SHALL BE PLACED OVER THE ENTIRE AREA PRIOR TO PLACING THE STONE. FILTER CLOTH IS NOT REQUIRED FOR A SINGLE FAMILY RESIDENCE LOT.
- ALL SURFACE WATER THAT IS FLOWING TO OR DIVERTED TOWARD THE CONSTRUCTION ENTRANCE SHALL BE PIPED BENEATH THE ENTRANCE. IF PIPING IS IMPRACTICAL, A BERM WITH 5:1 SLOPES THAT CAN BE GROSSED BY VEHICLES MAY BE SUBSTITUTED FOR THE PIPE.
- THE ENTRANCE SHALL BE MAINTAINED IN A CONDITION THAT WILL PREVENT TRACKING OR FLOWING OF SEDIMENT ONTO PUBLIC RIGHTS-OF-WAY. THIS MAY REQUIRE PERIODIC TOP DRESSING WITH ADDITIONAL STONE AS CONDITIONS DEMAND AND REPAIR AND/OR CLEANOUT OF ANY MEASURES USED TO TRAP SEDIMENT. ALL SEDIMENT SPILLED, WASHED, OR TRACKED ONTO PUBLIC RIGHT-OF-WAY MUST BE REMOVED PROMPTLY.
- WHEELS SHALL BE CLEANED TO REMOVE MUD PRIOR TO ENTRANCE ONTO PUBLIC RIGHT-OF-WAY, WHEN WASHING IS REQUIRED, IT SHALL BE DONE ON AN AREA STABILIZED WITH STONE WHICH DRAINS INTO AN APPROVED SEDIMENT TRAPPING DEVICE.

C C6 STABILIZED CONSTRUCTION ENTRANCE NTS

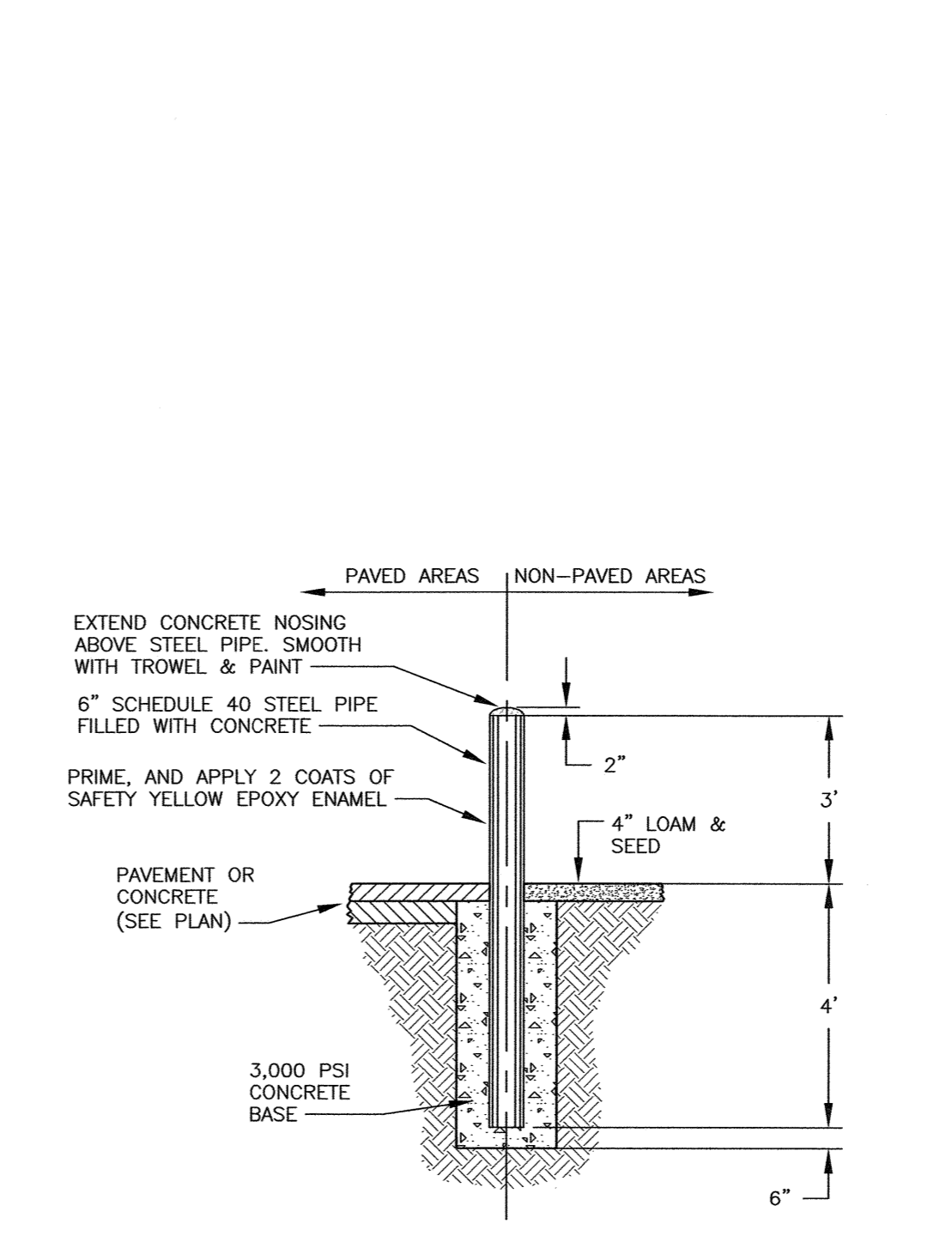

E C3 PIPE BOLLARD DETAIL NTS

APPROVED BY THE PORTSMOUTH PLANNING BOARD

CHAIRMAN _____ DATE _____

AMBIT ENGINEERING, INC.
 A DIVISION OF HALEY WARD, INC.

200 Griffin Road, Unit 3
 Portsmouth, NH 03801
 603.430.9282

WWW.HALEYWARD.COM

MIXED USE DEVELOPMENT
581 LAFAYETTE ROAD
PORTSMOUTH, N.H.

NO.	DESCRIPTION	DATE
0	ISSUED FOR COMMENT	11/20/23

Professional Engineer Seal for John R. Chagnon, No. 7851, State of New Hampshire.

SCALE: AS NOTED NOVEMBER 2023

EROSION CONTROL NOTES & DETAILS

D1

NOTES:
1) UNDERGROUND UTILITY LOCATIONS ARE BASED UPON BEST AVAILABLE EVIDENCE AND ARE NOT FIELD VERIFIED. LOCATING AND PROTECTING ANY ABOVEGROUND OR UNDERGROUND UTILITIES IS THE SOLE RESPONSIBILITY OF THE CONTRACTOR AND/OR THE OWNER. UTILITY CONFLICTS SHOULD BE REPORTED AT ONCE TO THE DESIGN ENGINEER.

2) THE CONTRACTOR SHALL NOTIFY DIG SAFE AT 1-888-DIG-SAFE (1-888-344-7233) AT LEAST 72 HOURS PRIOR TO COMMENCING ANY EXCAVATION ON PUBLIC OR PRIVATE PROPERTY.

3) CONTRACTOR SHALL INSTALL AND MAINTAIN EROSION CONTROL MEASURES IN ACCORDANCE WITH THE "NEW HAMPSHIRE STORMWATER MANUAL, VOLUME 3, EROSION AND SEDIMENT CONTROLS DURING CONSTRUCTION. (NHDES DECEMBER 2008).

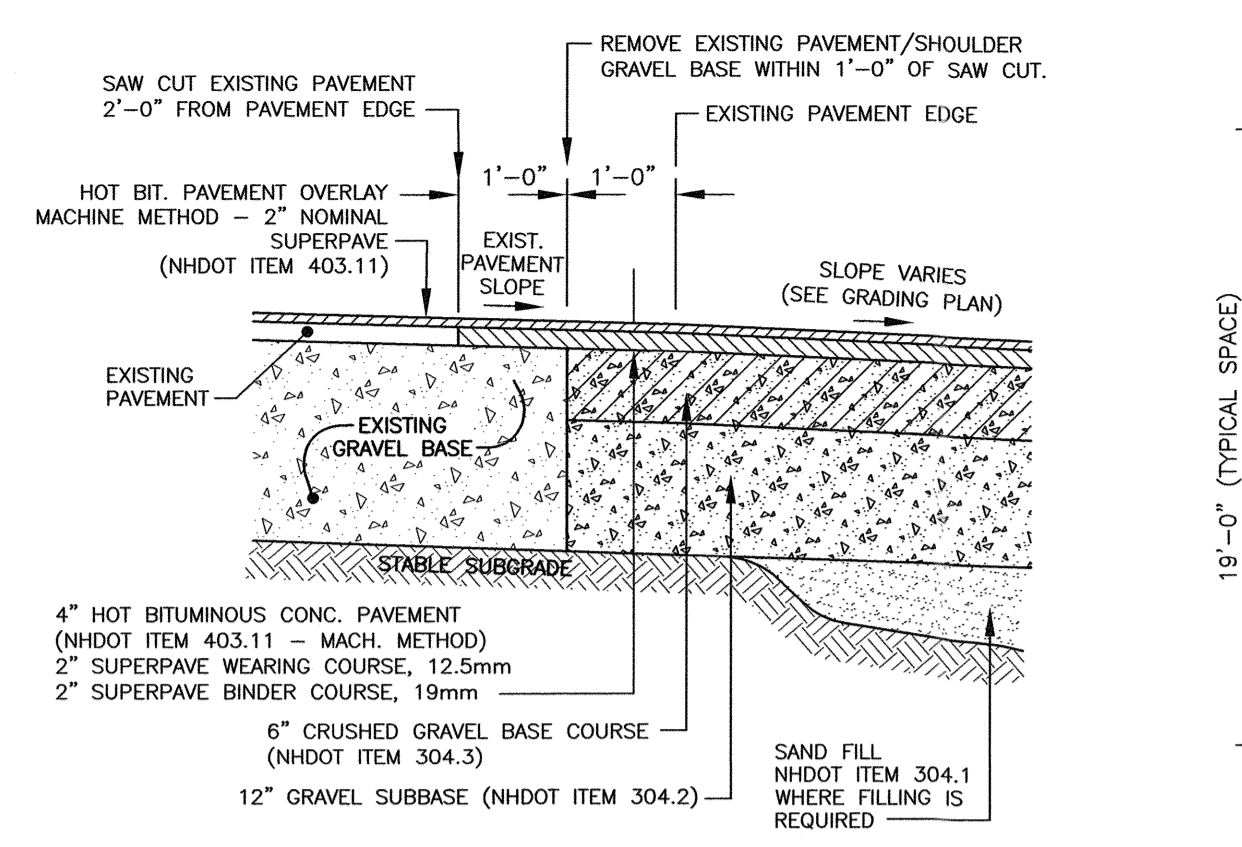

F
C3
FULL DEPTH PAVEMENT SECTION AND PAVEMENT JOINT DETAIL
NTS

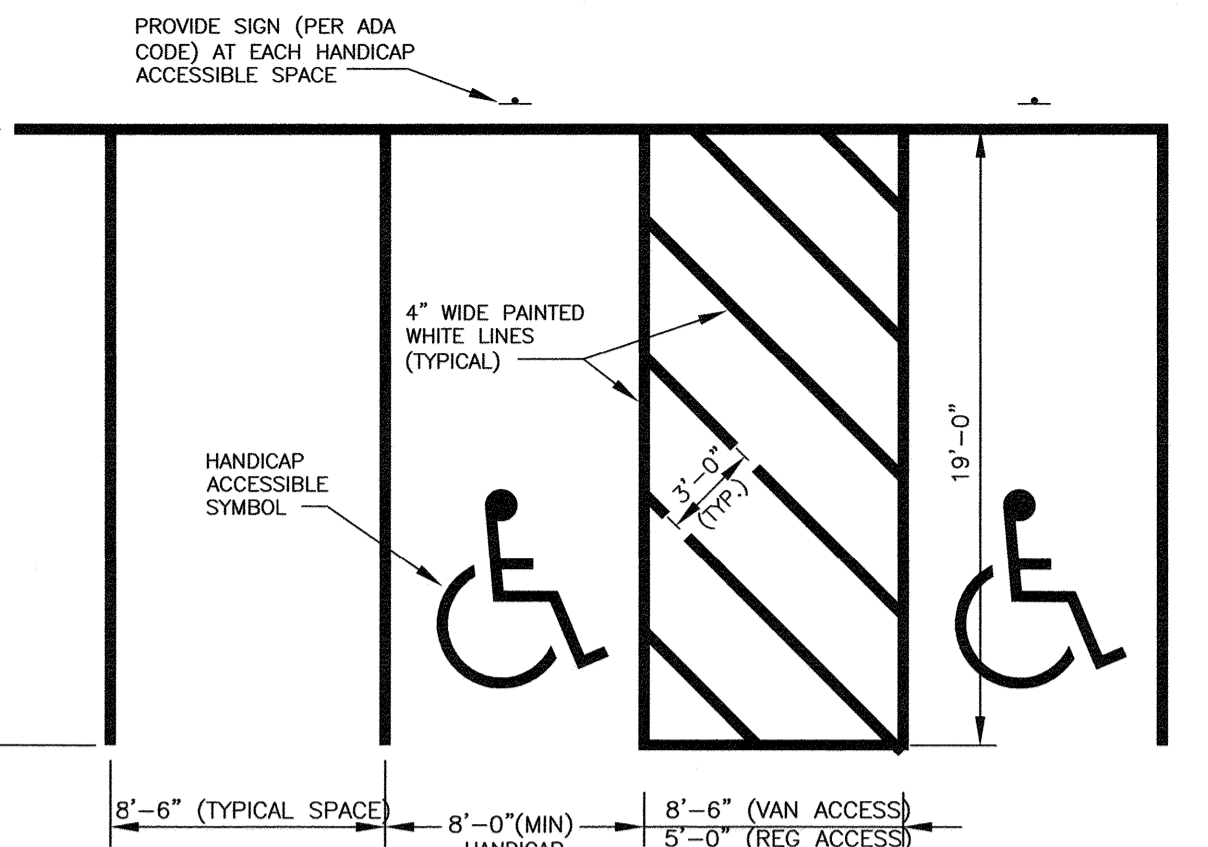

J
C3
PARKING STALL DETAIL
NTS

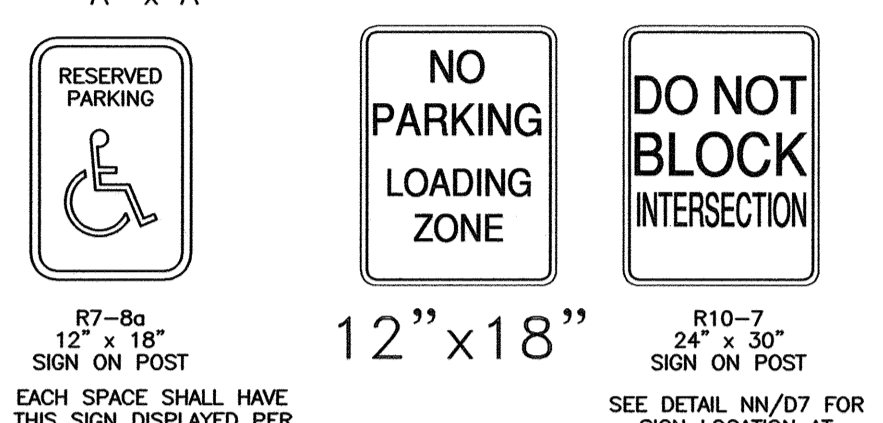
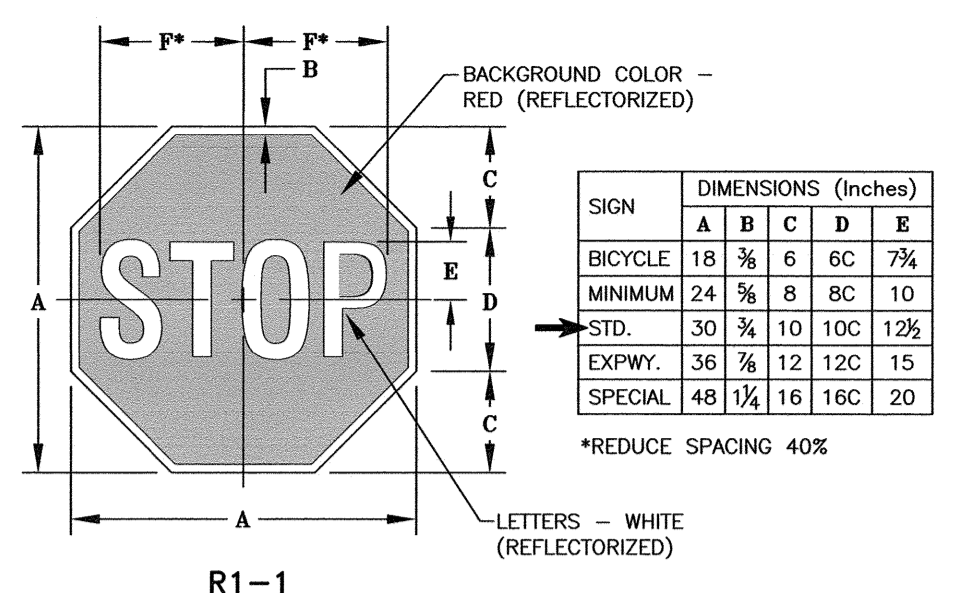

R7-8a
12" x 18"
SIGN ON POST
EACH SPACE SHALL HAVE THIS SIGN DISPLAYED PER ADA CODE

R10-7
24" x 30"
SIGN ON POST
SEE DETAIL NN/D7 FOR SIGN LOCATION AT INTERSECTION OF LEDGWOOD DRIVE AND LAFAYETTE ROAD

R5-1
30" x 30"
SIGN DETAILS
NTS

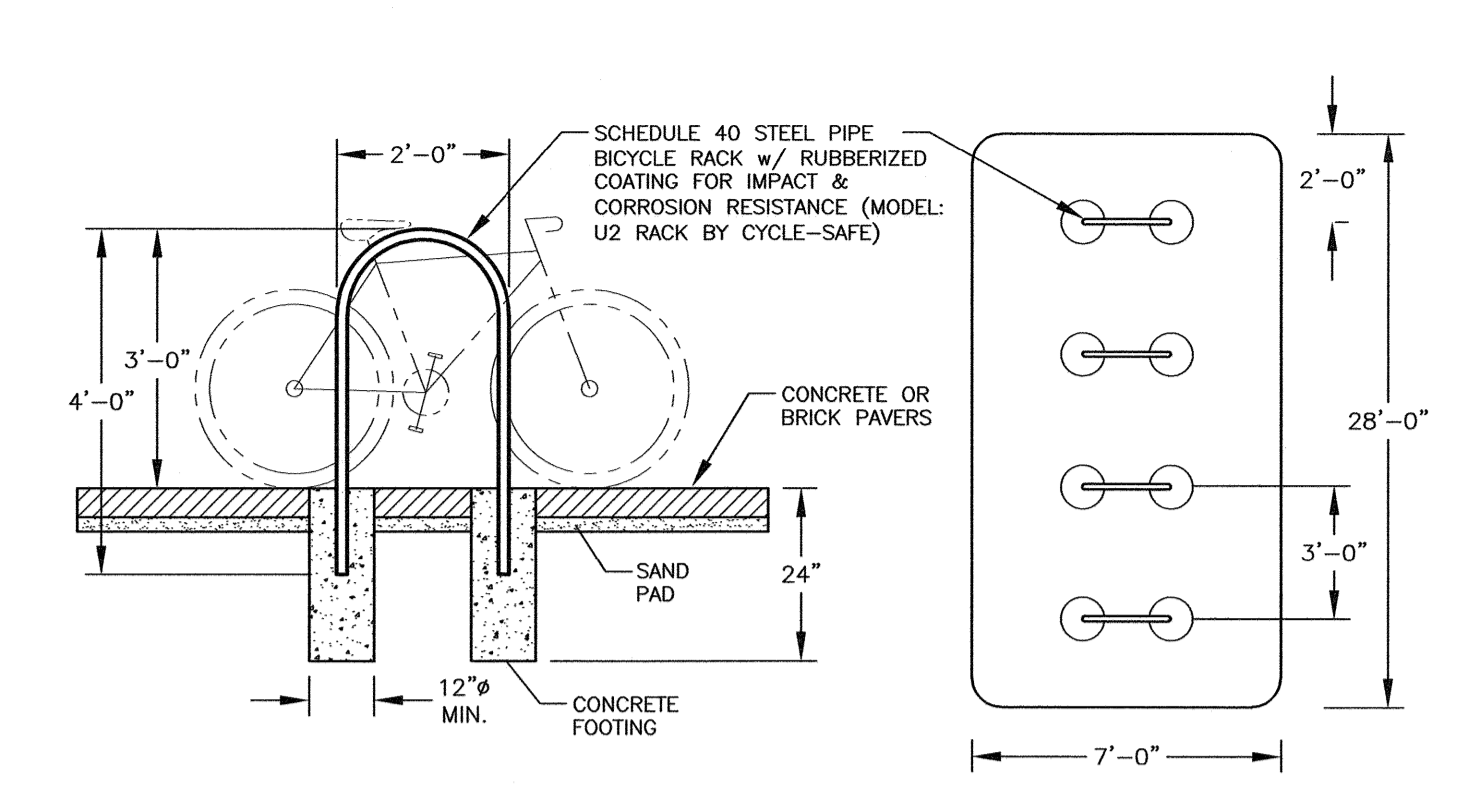

N
C3
UPTURNED "U" BICYCLE RACK
NTS

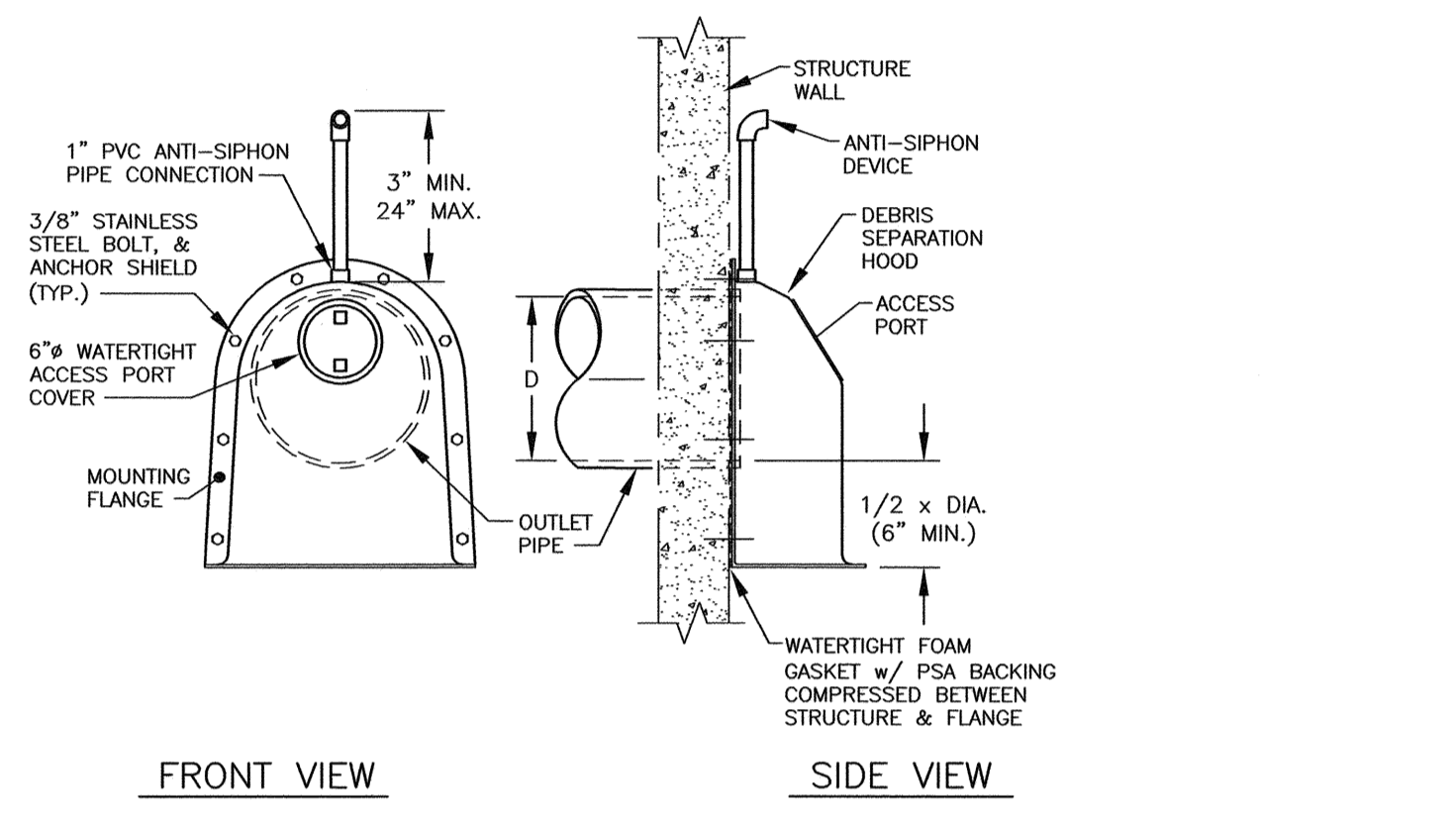

O
C6
CATCH BASIN OUTLET HOOD DETAIL
NTS

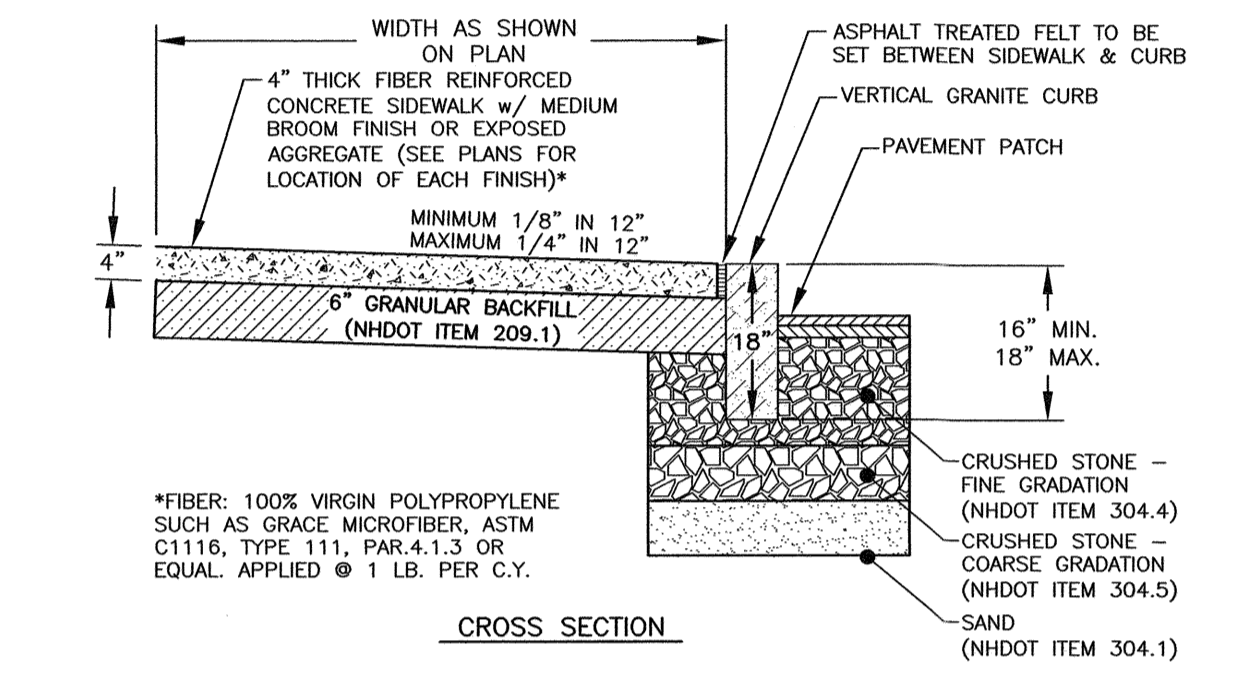

G
C3
PORTLAND CEMENT CONCRETE SIDEWALK
NTS

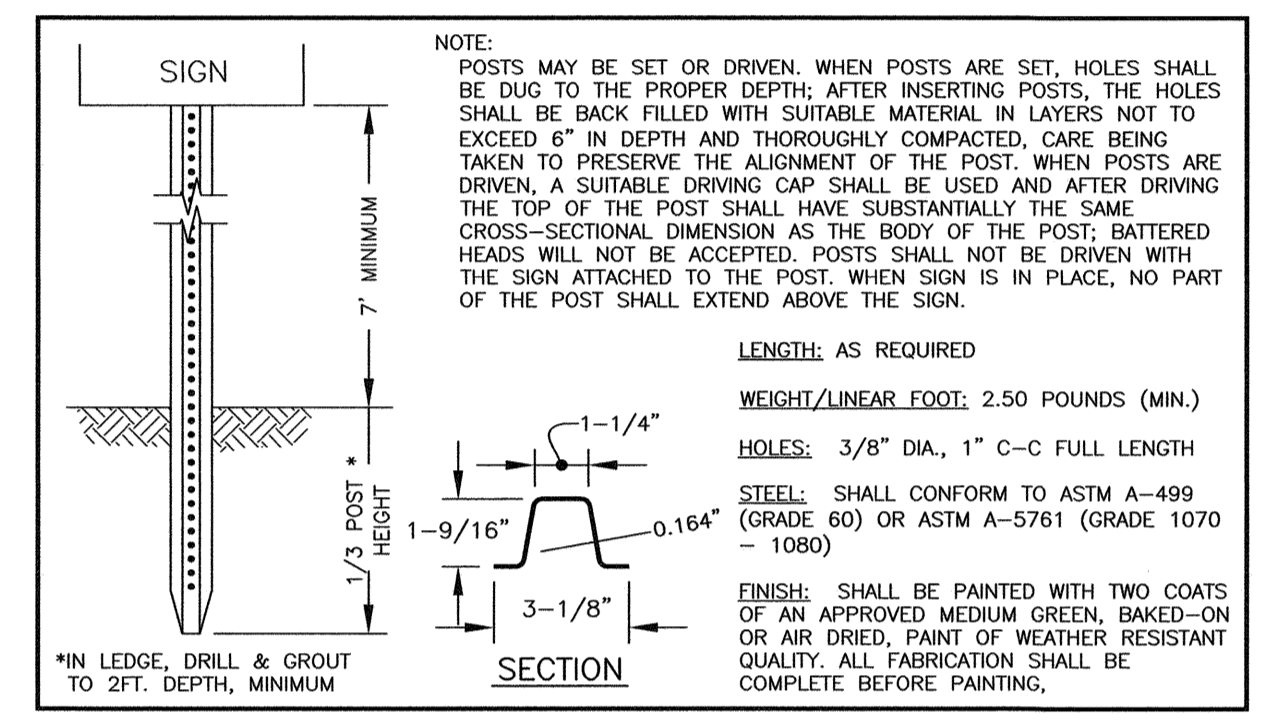

K
C3
SIGN POST DETAIL
NTS

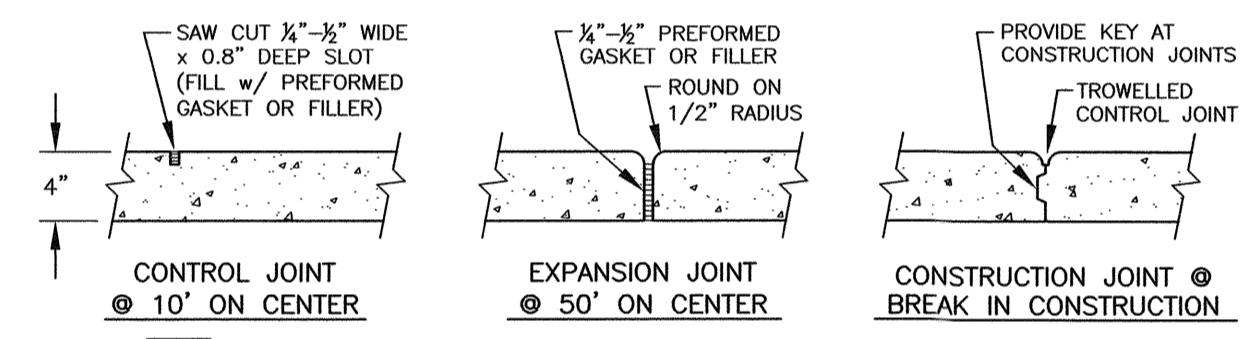

H
C3
GRANITE CURBING DETAILS (CITY OF PORTSMOUTH)
NTS

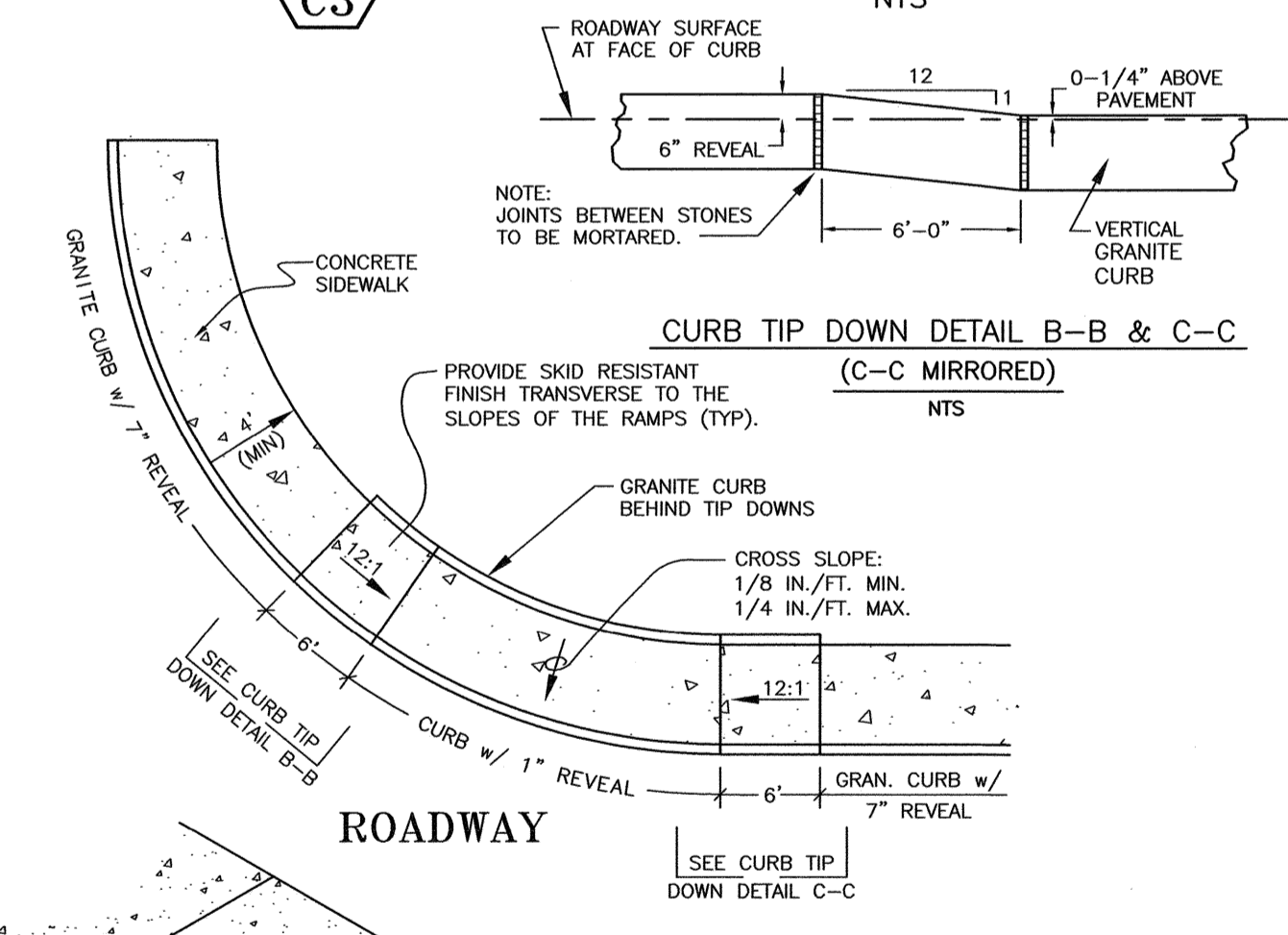

L
C3
TIP DOWNS FOR CONCRETE SIDEWALK
NTS

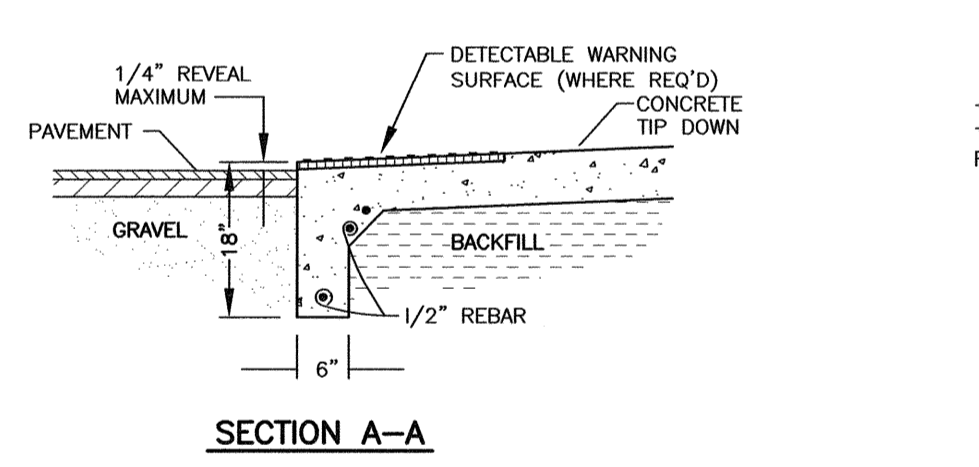

M
C3
GRANITE CURB END FOR VERTICAL GRANITE CURB
NTS

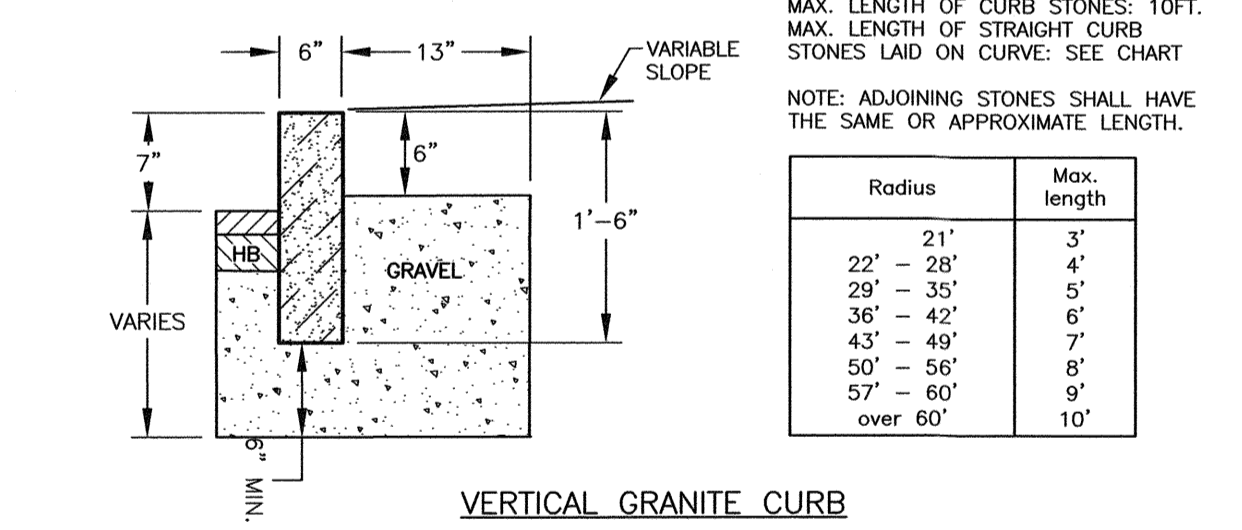

I
C3
PAINTED CROSSWALK DETAIL
NTS

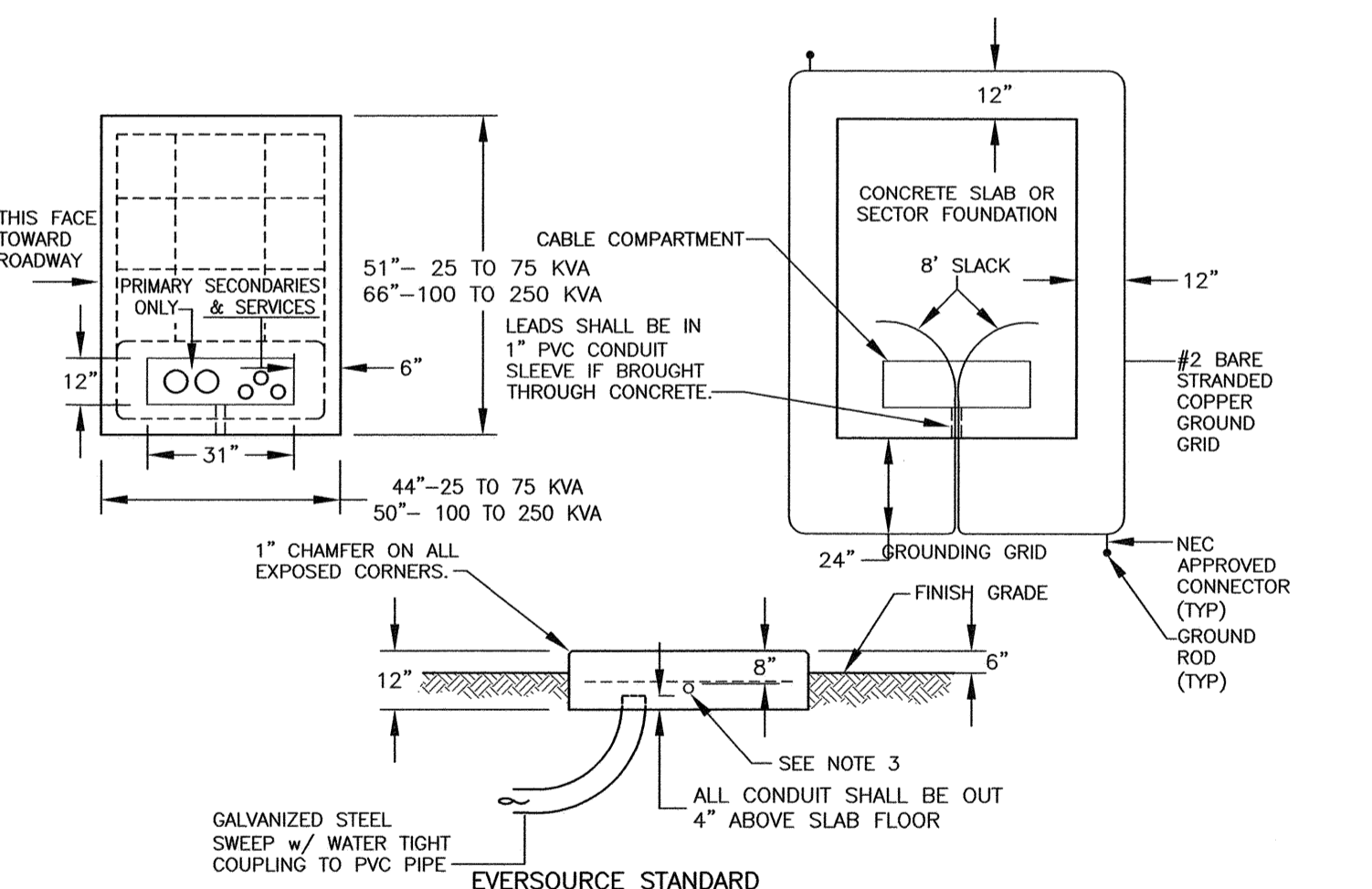

P
C5
TRANSFORMER PAD
COORDINATE WITH EVERSOURCE
NTS

CONSTRUCTION SPECIFICATIONS:
1) SLOPE OF RAMP VARIES WITH SIDEWALK WIDTH & HEIGHT, WITH A MAXIMUM SLOPE OF 12 : 1 AND A MINIMUM SLOPE OF 16 : 1.
2) A SKID RESISTANT FINISH TRANSVERSE TO THE SLOPE OF THE RAMP AND WARPED SIDEWALK, SHALL BE USED ON PORTLAND CEMENT CONCRETE RAMP.

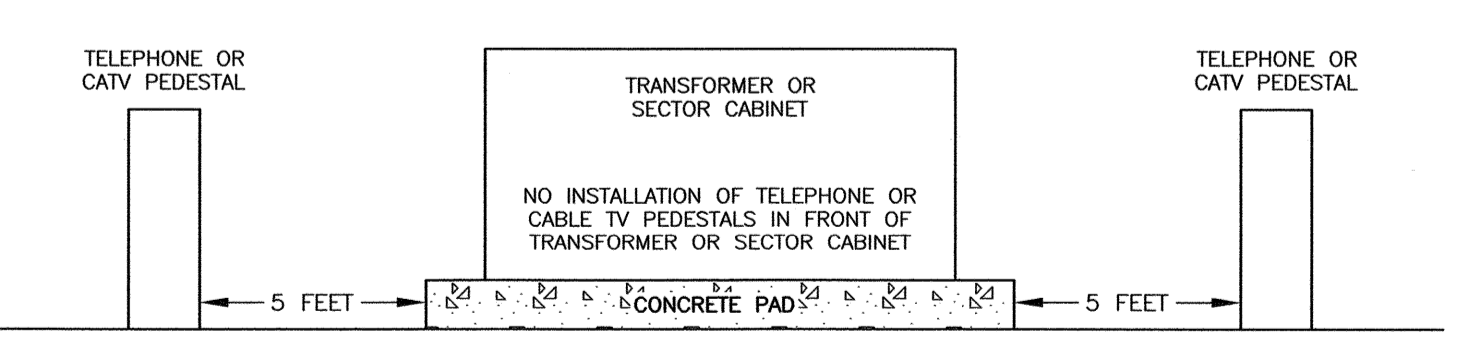

NOTES:
1. ALL REINFORCING TO BE #6 BARS.
2. 1" PVC CONDUIT SLEEVE FOR GROUND LEADS.
3. THE GROUND GRID SHALL BE SUPPLIED AND INSTALLED BY THE CONTRACTOR AND IS TO BE BURIED AT LEAST 12" BELOW GRADE. EIGHT FEET OF EXTRA WIRE FOR EACH GROUND GRID LEG SHALL BE LEFT EXPOSED IN THE CABLE COMPARTMENT TO ALLOW FOR THE CONNECTION TO THE TRANSFORMER. THE TWO 8' GROUND RODS MAY BE EITHER GALVANIZED STEEL OR COPPERWELD AND THEY SHALL BE CONNECTED TO THE GRID WITH NEC APPROVED CONNECTORS.
4. NO SHRUBS, FENCES, OR PERMANENT STRUCTURES CAN BE PLACED WITHIN 10 FEET OF THE FRONT AND 5 FEET OF THE SIDES AND BACK OF PAD-MOUNTED EQUIPMENT. THE COMPANY HAS THE RIGHT TO REMOVE THESE OBJECTS WITHOUT NOTICE TO THE OWNER.

MIXED USE DEVELOPMENT
581 LAFAYETTE ROAD
PORTSMOUTH, N.H.

NO.	ISSUED FOR COMMENT	11/20/23
	DESCRIPTION	DATE

REVISIONS	

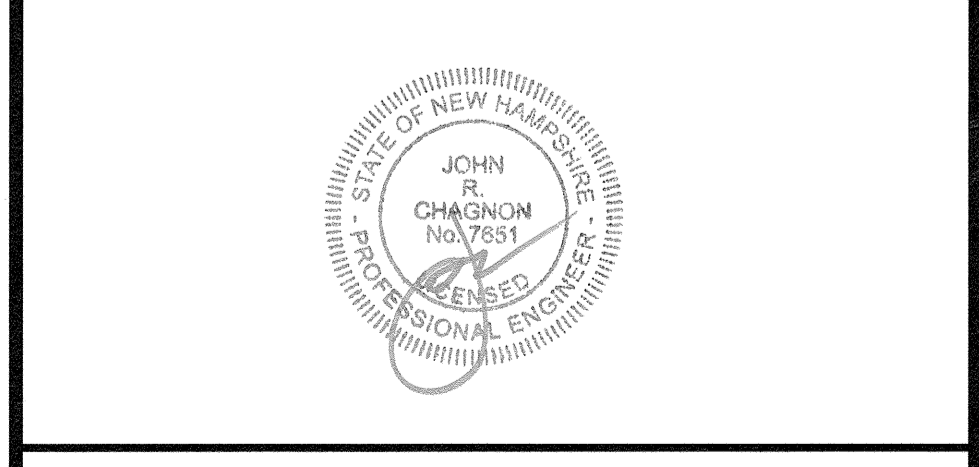

SCALE: AS NOTED NOVEMBER 2023

DETAILS **D2**

APPROVED BY THE PORTSMOUTH PLANNING BOARD
CHAIRMAN _____ DATE _____

NOTES:
1) UNDERGROUND UTILITY LOCATIONS ARE BASED UPON BEST AVAILABLE EVIDENCE AND ARE NOT FIELD VERIFIED. LOCATING AND PROTECTING ANY ABOVEGROUND OR UNDERGROUND UTILITIES IS THE SOLE RESPONSIBILITY OF THE CONTRACTOR AND/OR THE OWNER. UTILITY CONFLICTS SHOULD BE REPORTED AT ONCE TO THE DESIGN ENGINEER.

2) THE CONTRACTOR SHALL NOTIFY DIG SAFE AT 1-888-DIG-SAFE (1-888-344-7233) AT LEAST 72 HOURS PRIOR TO COMMENCING ANY EXCAVATION ON PUBLIC OR PRIVATE PROPERTY.

3) CONTRACTOR SHALL INSTALL AND MAINTAIN EROSION CONTROL MEASURES IN ACCORDANCE WITH THE "NEW HAMPSHIRE STORMWATER MANUAL, VOLUME 3, EROSION AND SEDIMENT CONTROLS DURING CONSTRUCTION. (NHDES DECEMBER 2008).

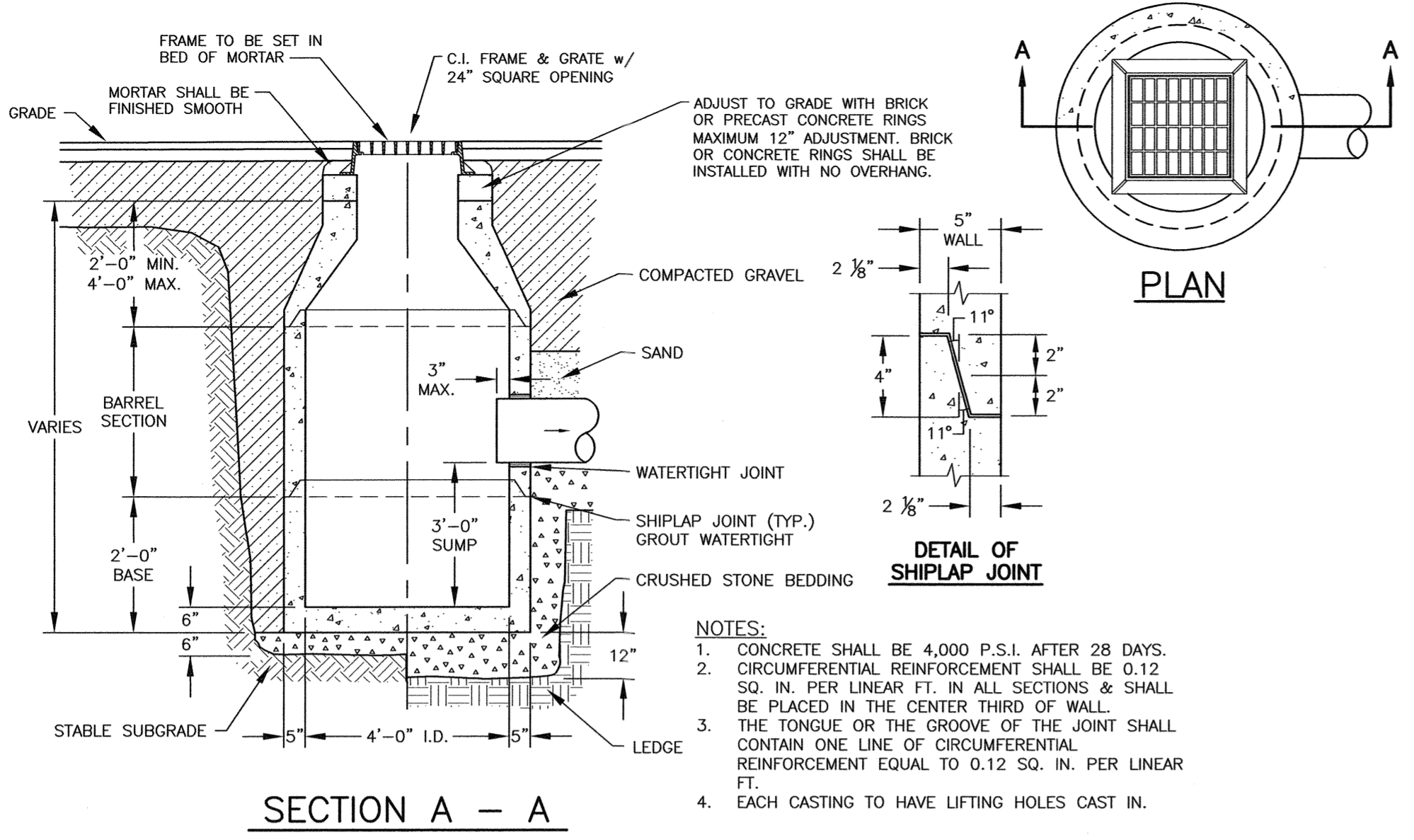

- NOTES:**
1. CONCRETE SHALL BE 4,000 P.S.I. AFTER 28 DAYS.
2. CIRCUMFERENTIAL REINFORCEMENT SHALL BE 0.12 SQ. IN. PER LINEAR FT. IN ALL SECTIONS & SHALL BE PLACED IN THE CENTER THIRD OF WALL.
3. THE TONGUE OR THE GROOVE OF THE JOINT SHALL CONTAIN ONE LINE OF CIRCUMFERENTIAL REINFORCEMENT EQUAL TO 0.12 SQ. IN. PER LINEAR FT.
4. EACH CASTING TO HAVE LIFTING HOLES CAST IN.

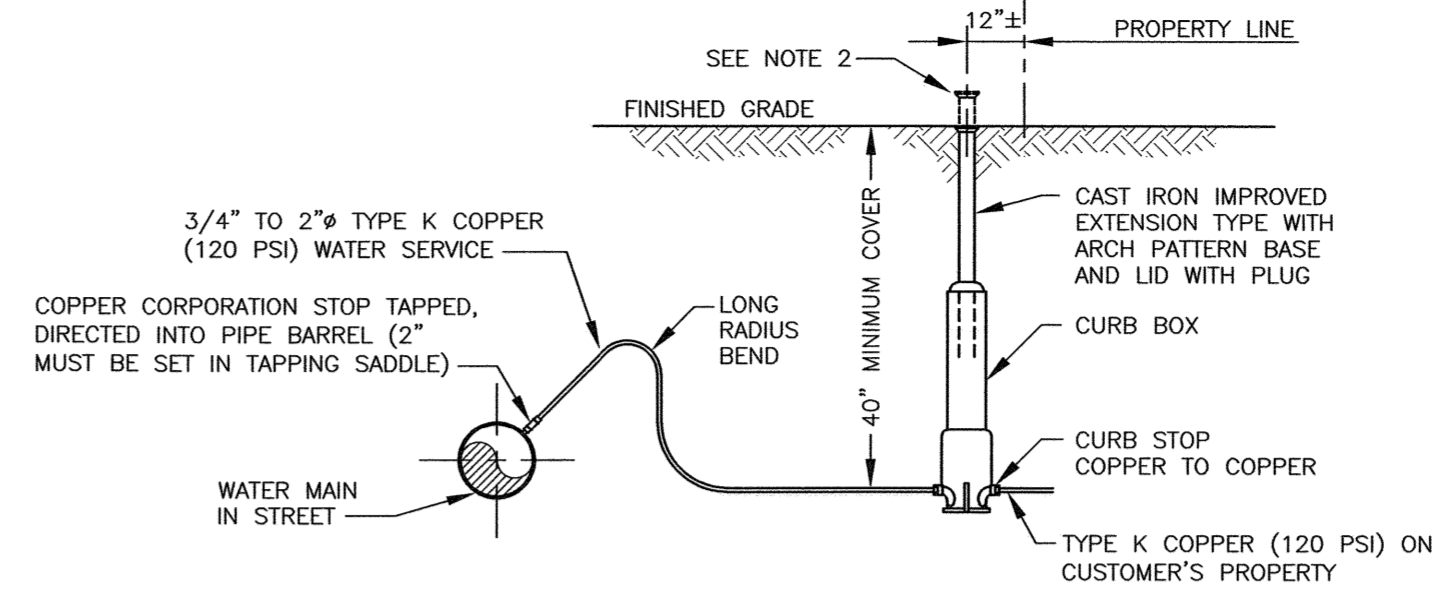
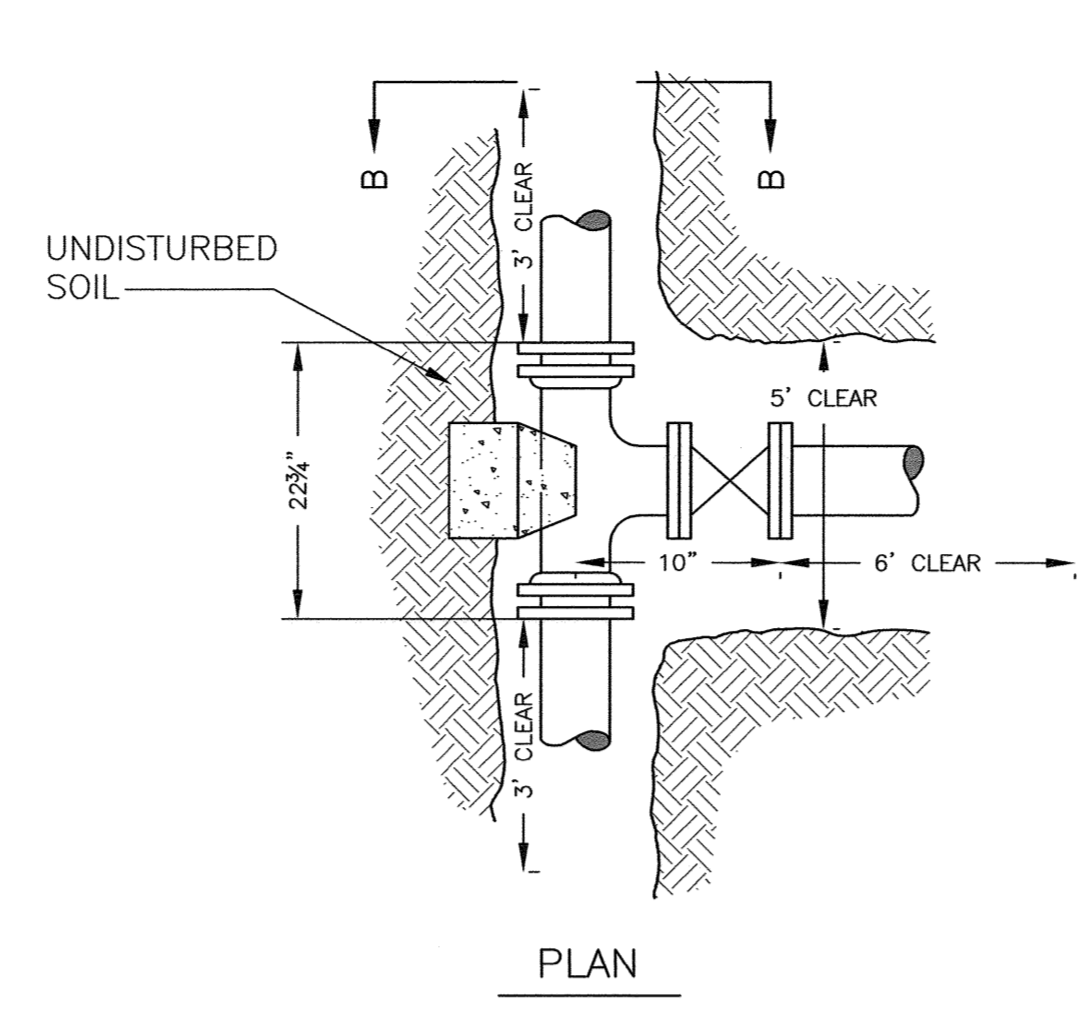

- NOTES:**
1) ALL MATERIALS SHALL BE APPROVED BY THE PORTSMOUTH WATER DEPARTMENT PRIOR TO INSTALLATION AND USE.
2) ALL JOINTS SHALL BE MECHANICAL.
3) "CLEAR" DIMENSIONS SHOWN ARE REQUIRED FOR WORKSPACE. NO JOINTS ON PIPE BEING TAPPED WITHIN "CLEAR" AREA.
4) FORD TYPE STAINLESS STEEL TAPPING SADDLES OR APPROVED EQUAL ARE ALSO ACCEPTABLE.

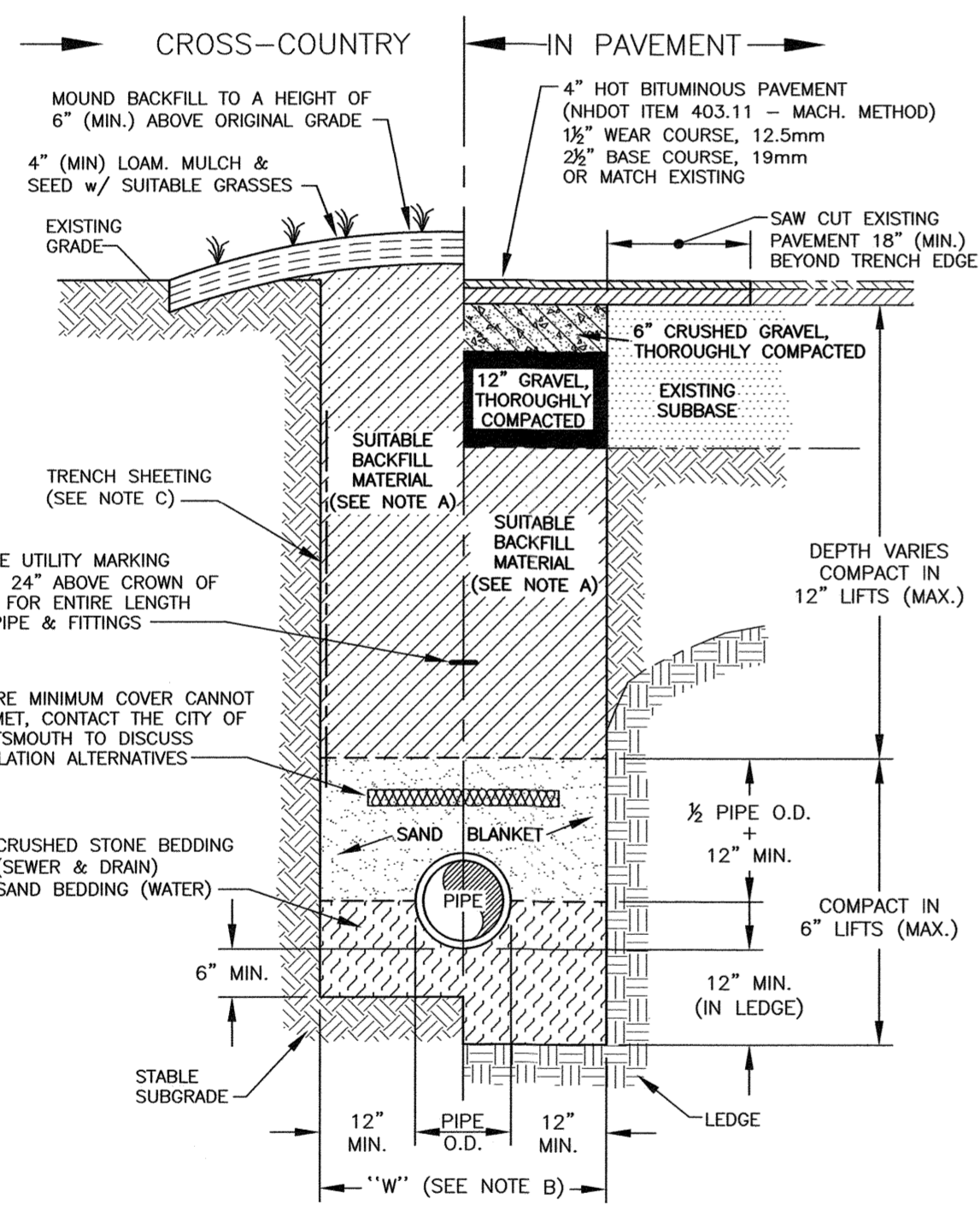

T TAPPING SLEEVE AND GATE
C4 INSTALL PER PORTSMOUTH REQUIREMENTS NTS

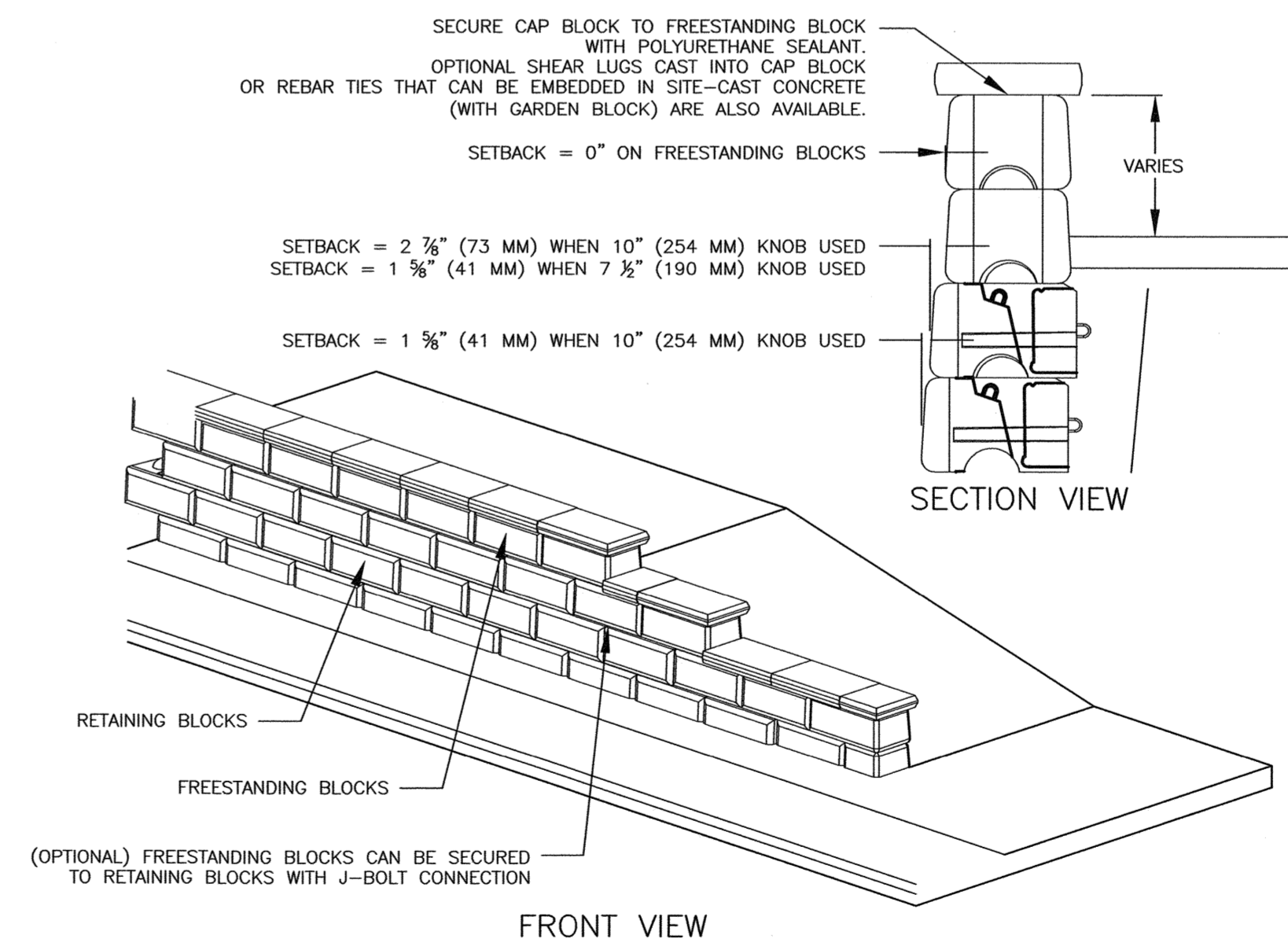
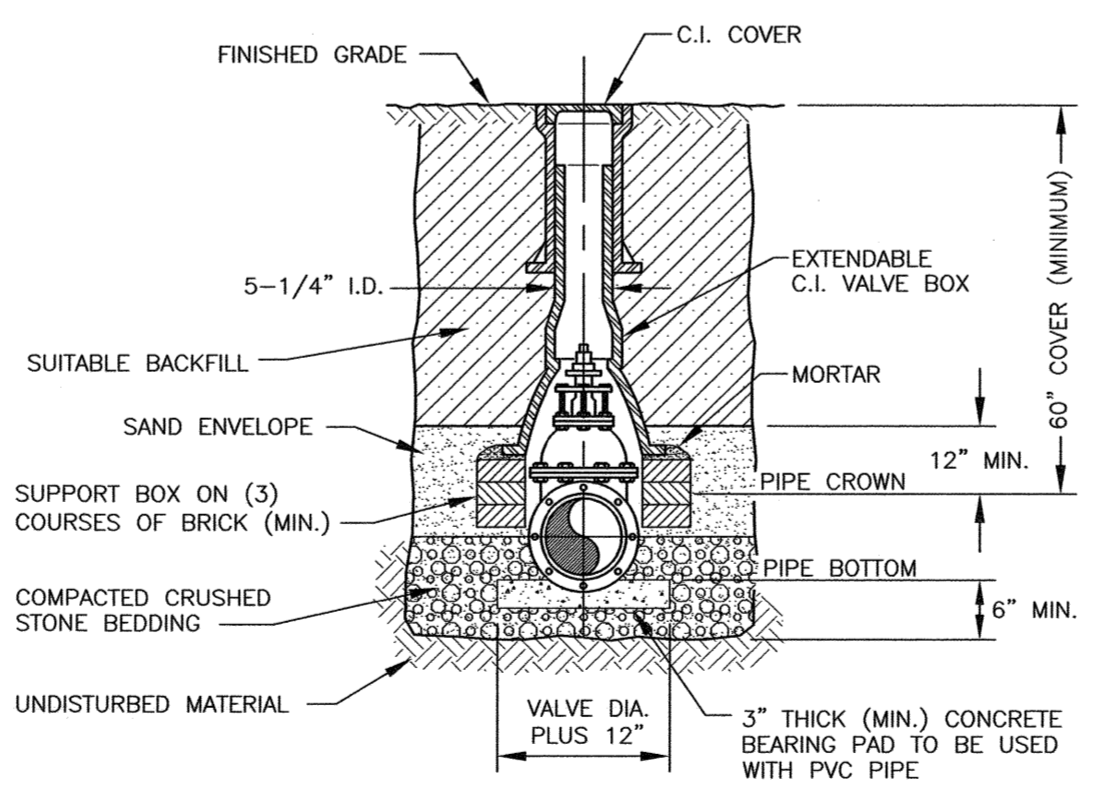

R TYPICAL PIPE TRENCH
C4 NTS

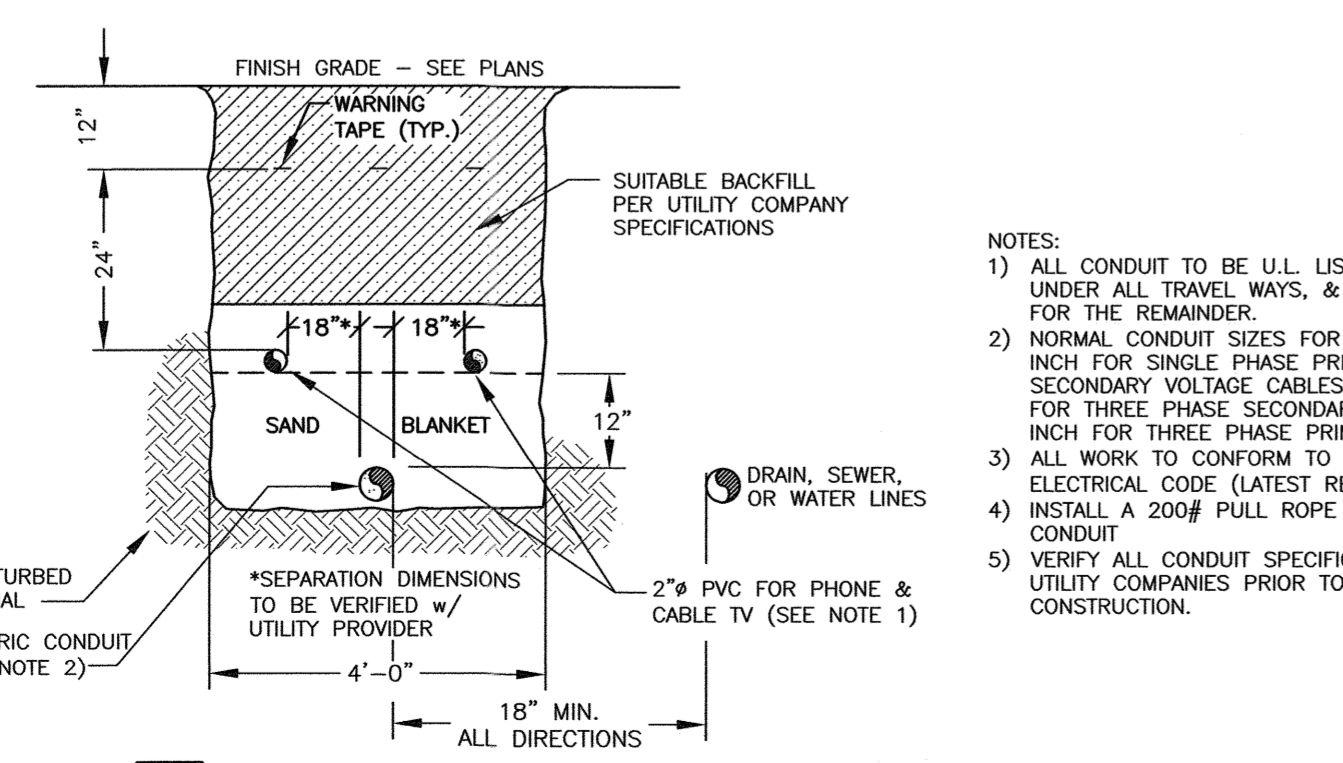

- NOTES:**
1) ALL CONDUIT TO BE U.L. LISTED, SCH. 80 UNDER ALL TRAVEL WAYS, & SCH. 40 FOR THE REMAINDER.
2) NORMAL CONDUIT SIZES FOR PSNH ARE 3 INCH FOR SINGLE PHASE PRIMARY AND SECONDARY VOLTAGE CABLES, 4 INCH FOR THREE PHASE SECONDARY, AND 5 INCH FOR THREE PHASE PRIMARY.
3) ALL WORK TO CONFORM TO THE NATIONAL ELECTRICAL CODE (LATEST REVISION)
4) INSTALL A 200# PULL ROPE FOR EACH CONDUIT
5) VERIFY ALL CONDUIT SPECIFICATIONS WITH UTILITY COMPANIES PRIOR TO ANY CONSTRUCTION.

APPROVED BY THE PORTSMOUTH PLANNING BOARD

CHAIRMAN _____ DATE _____

MIXED USE DEVELOPMENT
581 LAFAYETTE ROAD
PORTSMOUTH, N.H.

0	ISSUED FOR COMMENT	11/20/23
NO.	DESCRIPTION	DATE
REVISIONS		

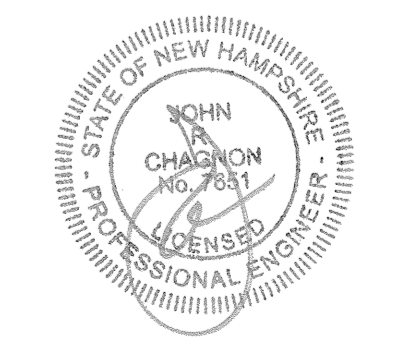

SCALE: AS NOTED NOVEMBER 2023

DETAILS **D3**

JELLYFISH DESIGN NOTES

JELLYFISH TREATMENT CAPACITY IS A FUNCTION OF THE CARTRIDGE LENGTH AND THE NUMBER OF CARTRIDGES. THE STANDARD PEAK DIVERSION STYLE WITH PRECAST TOP SLAB IS SHOWN. ALTERNATE OFFLINE VAULT AND/OR SHALLOW ORIENTATIONS ARE AVAILABLE. PEAK CONVEYANCE CAPACITY TO BE DETERMINED BY ENGINEER OF RECORD.

CARTRIDGE SELECTION	54"	40"	27"	15"
CARTRIDGE LENGTH	6'-4"	6'-4"	4'-3"	3'-3"
OUTLET INVERT TO STRUCTURE INVERT (A)	0.47'	0.47'	0.089'	0.049' / 0.025'
FLOW RATE HI-FLO / DRAINDOWN (CFS) PER CART	1.96	1.47	0.98	0.54
MAX. TREATMENT (CFS)	5.00	4.00	4.00	4.00
DECK TO INSIDE TOP (MIN) (B)				

- GENERAL NOTES:**
- CONTECH TO PROVIDE ALL MATERIALS UNLESS NOTED OTHERWISE.
 - FOR SITE SPECIFIC DRAWINGS WITH DETAILED STRUCTURE DIMENSIONS AND WEIGHT, PLEASE CONTACT YOUR CONTECH ENGINEERED SOLUTIONS REPRESENTATIVE. www.conteches.com
 - JELLYFISH WATER QUALITY STRUCTURE SHALL BE IN ACCORDANCE WITH ALL DESIGN DATA AND INFORMATION CONTAINED IN THIS DRAWING. CONTRACTOR TO CONFIRM STRUCTURE MEETS REQUIREMENTS OF PROJECT.
 - STRUCTURE SHALL MEET AASHTO HS-20 OR PER APPROVING JURISDICTION REQUIREMENTS, WHICHEVER IS MORE STRINGENT, ASSUMING EARTH COVER OF 10' - 12' AND GROUNDWATER ELEVATION AT OR BELOW THE OUTLET PIPE INVERT ELEVATION. ENGINEER OF RECORD TO CONFIRM ACTUAL GROUNDWATER ELEVATION. CASTINGS SHALL MEET AASHTO M306 LOAD RATING AND BE CAST WITH THE CONTECH LOGO.
 - STRUCTURE SHALL BE PRECAST CONCRETE CONFORMING TO ASTM C-867, ASTM C-918, AND AASHTO LOAD FACTOR DESIGN METHOD.
 - OUTLET PIPE INVERT IS EQUAL TO THE CARTRIDGE DECK ELEVATION.
 - THE OUTLET PIPE DIAMETER FOR NEW INSTALLATIONS IS RECOMMENDED TO BE ONE PIPE SIZE LARGER THAN THE INLET PIPE AT EQUAL OR GREATER SLOPE.
 - NO PRODUCT SUBSTITUTIONS SHALL BE ACCEPTED UNLESS SUBMITTED 10 DAYS PRIOR TO PROJECT BID DATE, OR AS DIRECTED BY THE ENGINEER OF RECORD.

- INSTALLATION NOTES:**
- ANY SUB-BASE, BACKFILL DEPTH, AND/OR ANTI-FLOTATION PROVISIONS ARE SITE-SPECIFIC DESIGN CONSIDERATIONS AND SHALL BE SPECIFIED BY ENGINEER OF RECORD.
 - CONTRACTOR TO PROVIDE EQUIPMENT WITH SUFFICIENT LIFTING AND REACH CAPACITY TO LIFT AND SET THE STRUCTURE.
 - CONTRACTOR WILL INSTALL AND LEVEL THE STRUCTURE, SEALING THE JOINTS, LINE ENTRY AND EXIT POINTS (NON-SHRINK GROUT WITH APPROVED WATERSTOP OR FLEXIBLE BOOT).
 - CARTRIDGE INSTALLATION, BY CONTECH, SHALL OCCUR ONLY AFTER SITE HAS BEEN STABILIZED AND THE JELLYFISH UNIT IS CLEAN AND FREE OF DEBRIS. CONTACT CONTECH TO COORDINATE CARTRIDGE INSTALLATION WITH SITE STABILIZATION.

SITE SPECIFIC DATA REQUIREMENTS

STRUCTURE ID	ID
WATER QUALITY FLOW RATE (cfs)	WQFLOW
PEAK FLOW RATE (cfs)	PEAK
RETURN PERIOD OF PEAK FLOW (yrs)	RETURN
# OF CARTRIDGES REQUIRED (HF / DD)	CART
CARTRIDGE LENGTH	SIZE
PIPE DATA: IE MATL DIA SLOPE % HGL	
INLET #1 ELEV MATL DIA SLOPE HGL	
INLET #2 ELEV MATL DIA SLOPE HGL	
OUTLET ELEV MATL DIA SLOPE HGL	

SEE GENERAL NOTES 6-7 FOR INLET AND OUTLET HYDRAULIC AND SIZING REQUIREMENTS

RIM ELEVATION	RIM ELEV
ANTI-FLOTATION BALLAST	WIDTH HEIGHT
	WIDTH HEIGHT

NOTES/SPECIAL REQUIREMENTS:
* PER ENGINEER OF RECORD

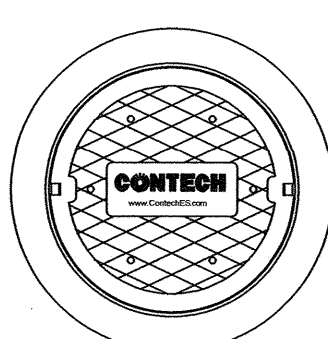

FRAME AND COVER
(DIAMETER VARIES)
N.T.S.

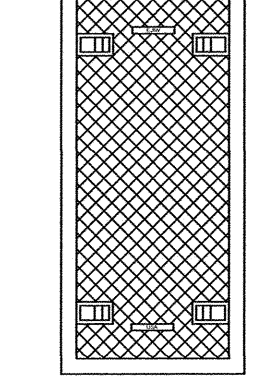

24" TRENCH COVER
(LENGTH VARIES)
N.T.S.

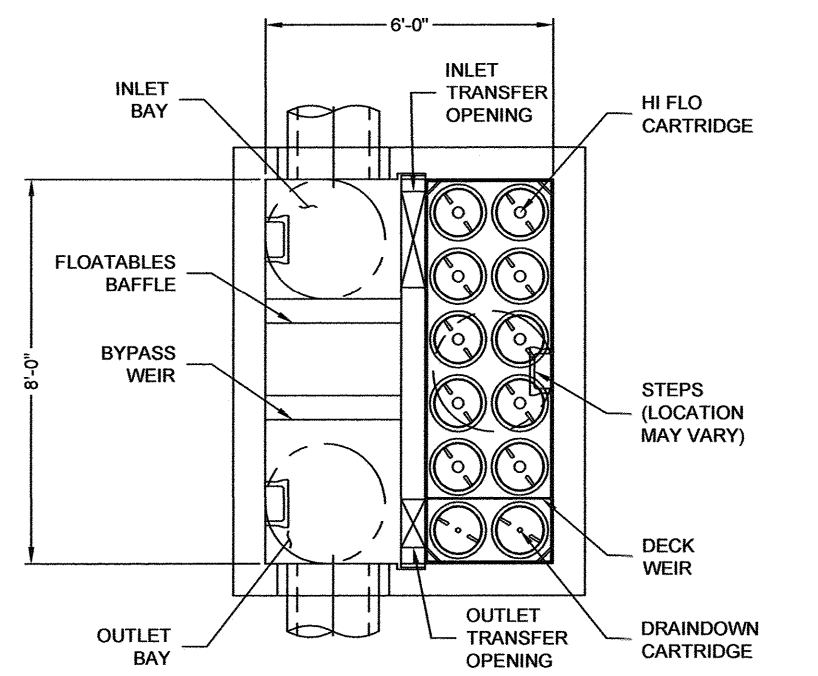

PLAN VIEW
(TOP SLAB NOT SHOWN FOR CLARITY)

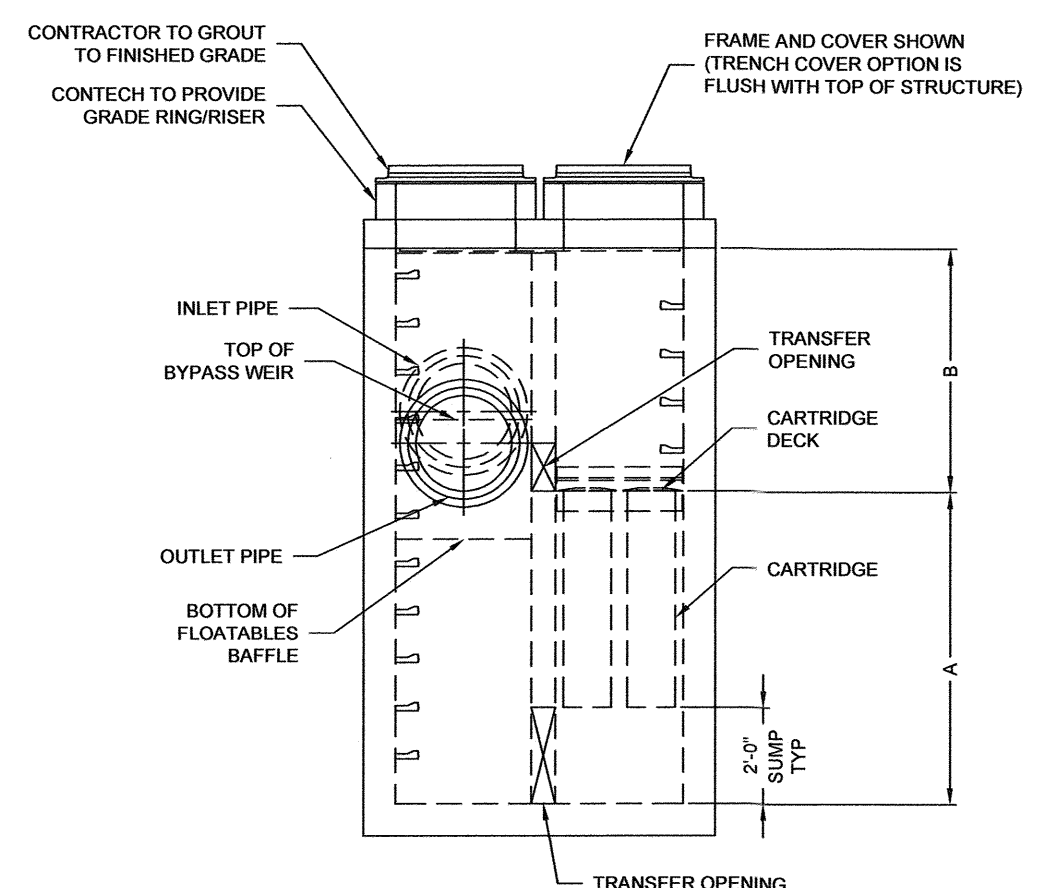

ELEVATION VIEW

JELLYFISH FILTER DETAIL
N.T.S.

1.0 Inspection and Maintenance Overview

The primary purpose of the Jellyfish® Filter is to capture and remove pollutants from stormwater runoff. As with any filtration system, these pollutants must be removed to maintain the filter's maximum treatment performance. Regular inspection and maintenance are required to insure proper functioning of the system.

- A minimum of quarterly inspections during the first year of operation to assess the sediment and floatable pollutant accumulation, and to ensure proper functioning of the system.
- Inspection frequency in subsequent years is based on the inspection and maintenance plan developed in the first year of operation. Minimum frequency should be once per year.
- Inspection is recommended after each major storm event.
- Inspection is required immediately after an upstream oil, fuel or other chemical spill.

3.0 Inspection Procedure

- The following procedure is recommended when performing inspections:
- Provide traffic control measures as necessary.
 - Inspect the MAW or inlet bay for floatable pollutants such as trash, debris, and oil sheen.
 - Measure oil and sediment depth in several locations, by lowering a sediment probe until contact is made with the floor of the structure. Record sediment depth, and presences of any oil layers.
 - Inspect cartridge lids. Missing or damaged cartridge lids to be replaced.
 - Inspect the MAW (where appropriate), cartridge deck and receptacles, and backwash pool weir, for damaged or broken components.

- Inspection activities are typically conducted from surface observations and include:
- Observe if standing water is present
 - Observe if there is any physical damage to the deck or cartridge lids
 - Observe the amount of debris in the Maintenance Access Wall (MAW) or inlet bay for vault systems
- Maintenance activities include:
- Removal of oil, floatable trash and debris
 - Removal of collected sediments
 - Rinsing and re-installing the filter cartridges
 - Replace filter cartridge tentacles, as needed

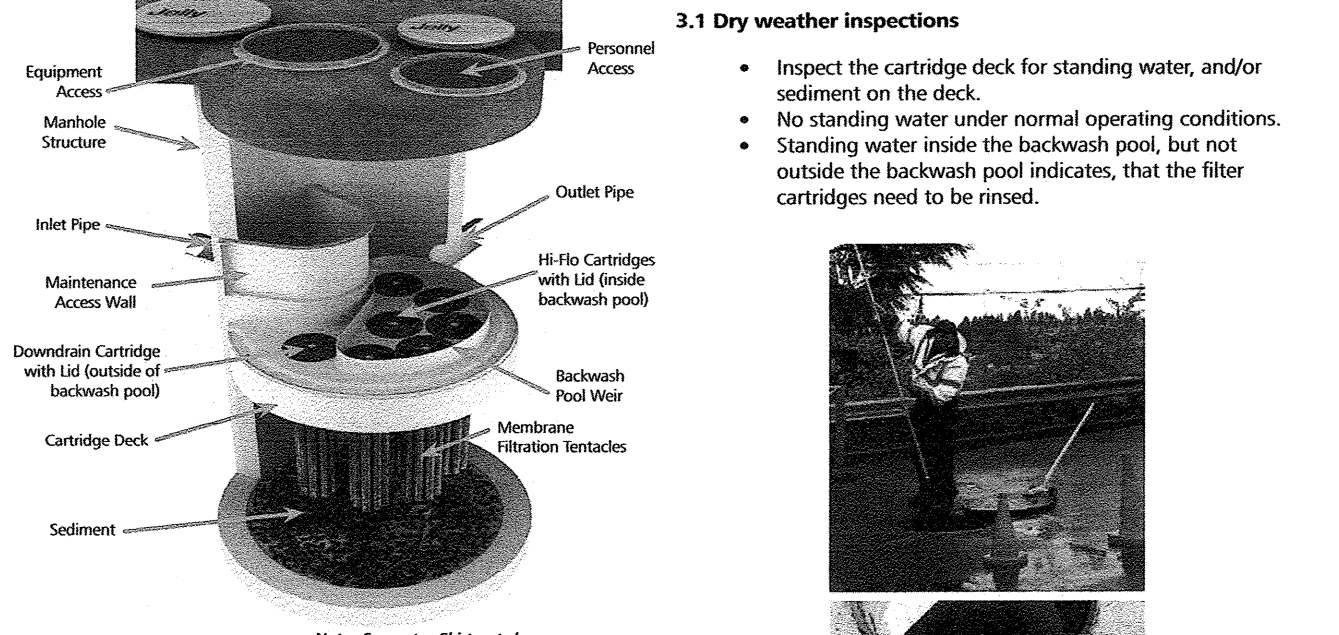

2.0 Inspection Timing

Inspection of the Jellyfish Filter is key in determining the maintenance requirements for, and to develop a history of, the site's pollutant loading characteristics. In general, inspections should be performed at the times indicated below, or per the approved project stormwater quality documents (if applicable), whichever is more frequent.

5.3 Sediment and Floatables Extraction

- Perform vacuum cleaning of the Jellyfish Filter only after filter cartridges have been removed from the system. Access the lower chamber for vacuum cleaning only through the maintenance access wall (MAW) opening. Be careful not to damage the flexible plastic separator skirt that is attached to the underside of the deck on manhole systems. Do not lower the vacuum wand through a cartridge receptacle, as damage to the receptacle will result.
- Vacuum floatable trash, debris, and oil, from the MAW opening or inlet bay. Alternatively, floatable solids may be removed by a net or skimmer.

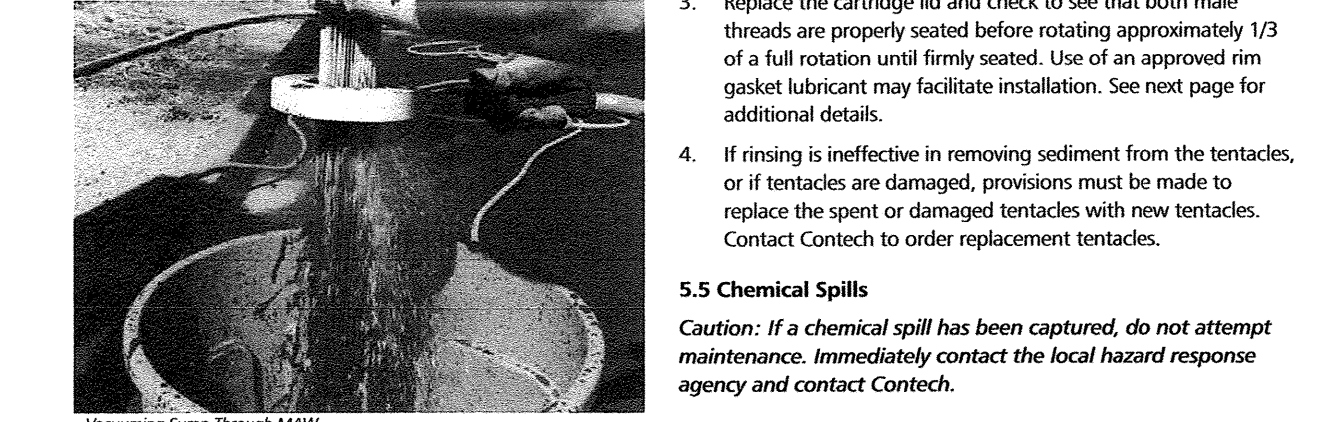

- Pressure wash cartridge deck and receptacles to remove all sediment and debris. Sediment should be rinsed into the sump area. Take care not to flush rinse water into the outlet pipe.
- Remove water from the sump area. Vacuum or pump equipment should only be introduced through the MAW or inlet bay.
- Remove the sediment from the bottom of the unit through the MAW or inlet bay opening.

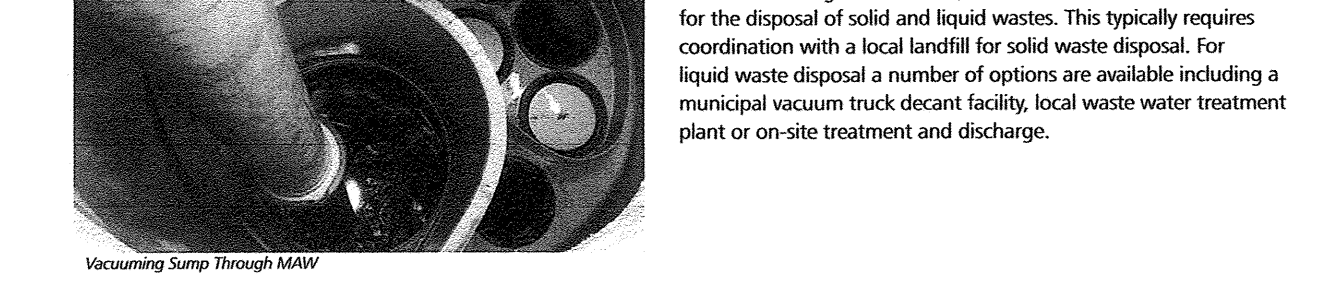

- Standing water outside the backwash pool is not anticipated and may indicate a backwater condition caused by high water elevation in the receiving water body, or possibly a blockage in downstream infrastructure.
- Any appreciable sediment (≥1/16") accumulated on the deck surface should be removed.

3.2 Wet weather inspections

- Observe the rate and movement of water in the unit. Note the depth of water above deck elevation within the MAW or inlet bay.
- Less than 6 inches, flow should be exiting the cartridge lids of each of the draindown cartridges (i.e. cartridges located outside the backwash pool).
- Greater than 6 inches, flow should be exiting the cartridge lids of each of the draindown cartridges and each of the hi-flo cartridges (i.e. cartridges located inside the backwash pool), and water should be overflowing the backwash pool weir.
- 18 inches or greater and relatively little flow is exiting the cartridge lids and outlet pipe, this condition indicates that the filter cartridges need to be rinsed.

4.0 Maintenance Requirements

Required maintenance for the Jellyfish Filter is based upon results of the most recent inspection, historical maintenance records, or the site specific water quality management plan, whichever is more frequent. In general, maintenance requires some combination of the following:

- Sediment removal for depths reaching 12 inches or greater, or within 3 years of the most recent sediment cleaning, whichever occurs sooner.
- Floatable trash, debris, and oil removal.
- Deck cleaned and free from sediment.
- Filter cartridges rinsed and re-installed as required by the most recent inspection results, or within 12 months of the most recent filter rinsing, whichever occurs sooner.
- Replace tentacles if rinsing does not restore adequate hydraulic capacity, remove accumulated sediment, or if damaged or missing. It is recommended that tentacles should remain in service no longer than 5 years before replacement.
- Damaged or missing cartridge deck components must be repaired or replaced as indicated by results of the most recent inspection.
- The unit must be cleaned out and filter cartridges inspected immediately after an upstream oil, fuel, or chemical spill. Filter cartridge tentacles should be replaced if damaged or compromised by the spill.

5.0 Maintenance Procedure

- The following procedures are recommended when maintaining the Jellyfish Filter:
- Provide traffic control measures as necessary.
 - Open all covers and hatches. Use ventilation equipment as required, according to confined space entry procedures. **Caution: Dropping objects onto the cartridge deck may cause damage.**

Jellyfish Filter Components & Filter Cartridge Assembly and Installation

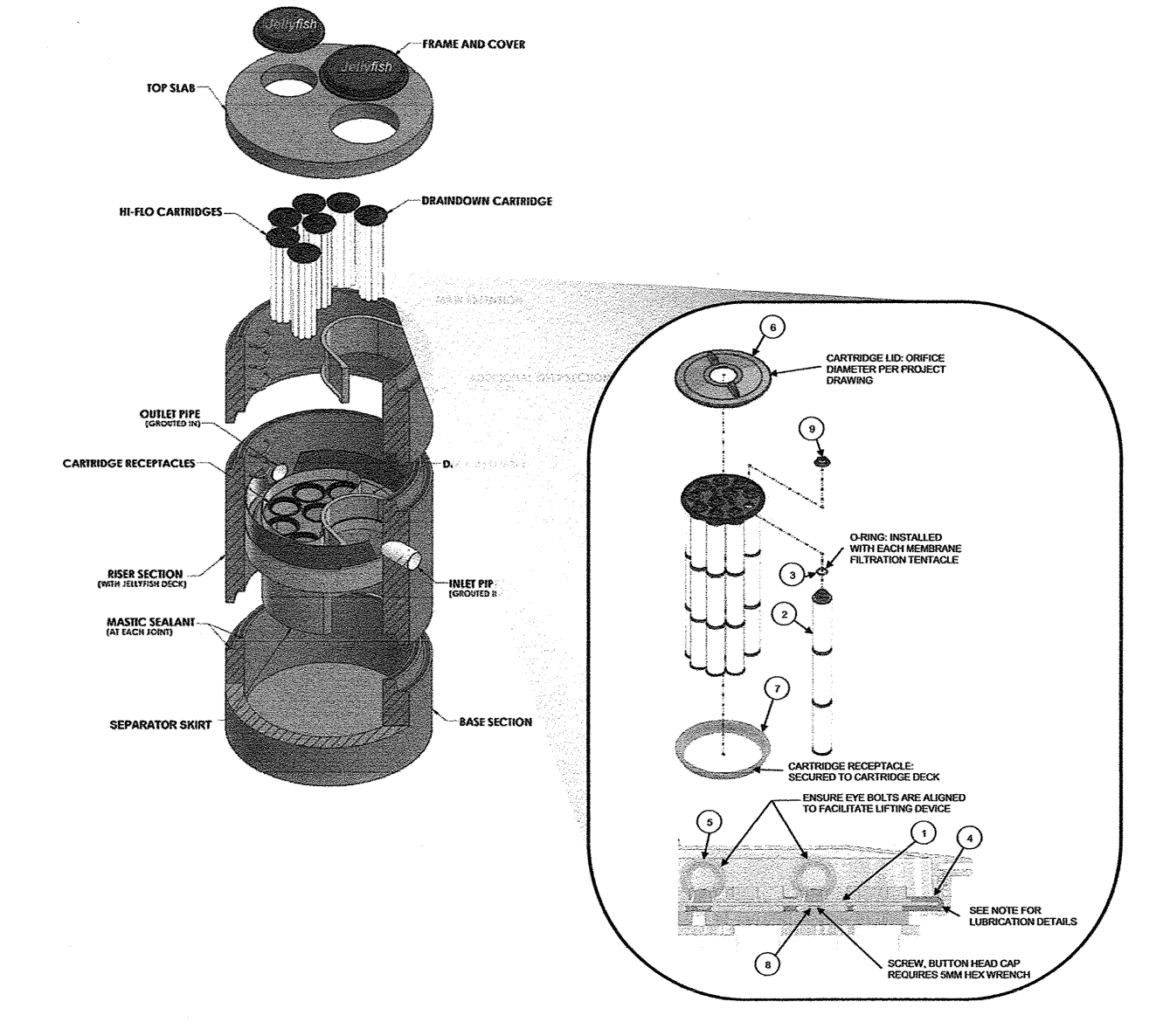

TABLE 1: BOM

ITEM NO.	DESCRIPTION
1	JF HEAD PLATE
2	JF TENTACLE
3	JF O-RING
4	JF HEAD PLATE GASKET
5	JF CARTRIDGE EYELET
6	JF 1/4" COVER
7	JF RECEPTACLE
8	BUITON HEAD CAP
9	JF CARTRIDGE NUT

TABLE 2: APPROVED GASKET LUBRICANTS

PART NO.	MFR.	DESCRIPTION
78713	LA-CO	LUBR-JOINT
40501	HERCULES	DOCK BUTTER
3960	QATEY	PIPE LUBRICANT
PROSELEC 10	PROSELECT	PIPE JOINT LUBRICANT

NOTES:

Head Plate Gasket Installation: Install Head Plate Gasket (Item 4) onto the Head Plate (Item 1) and liberally apply a lubricant from Table 2. Approved Gasket Lubricants onto the gasket where it contacts the Receptacle (Item 7) and Cartridge Lid (Item 6). Follow Lubricant manufacturer's instructions.

Lid Assembly: Rotate Cartridge Lid counter-clockwise until both male threads drop down and properly seat. Then rotate Cartridge Lid clockwise approximately one-third of a full rotation until Cartridge Lid is firmly secured, creating a watertight seal.

AMBIT ENGINEERING, INC.
A DIVISION OF HALEY WARD, INC.

200 Griffin Road, Unit 3
Portsmouth, NH 03801
603.430.9262

WWW.HALEYWARD.COM

- NOTES:**
- THE CONTRACTOR SHALL NOTIFY DIG SAFE AT 1-888-DIG-SAFE (1-888-344-7233) AT LEAST 72 HOURS PRIOR TO COMMENCING ANY EXCAVATION ON PUBLIC OR PRIVATE PROPERTY.
 - UNDERGROUND UTILITY LOCATIONS ARE BASED UPON BEST AVAILABLE EVIDENCE AND ARE NOT FIELD VERIFIED. LOCATING AND PROTECTING ANY ABOVEGROUND OR UNDERGROUND UTILITIES IS THE SOLE RESPONSIBILITY OF THE CONTRACTOR AND/OR THE OWNER. UTILITY CONFLICTS SHOULD BE REPORTED AT ONCE TO THE DESIGN ENGINEER.
 - CONTRACTOR SHALL INSTALL AND MAINTAIN EROSION CONTROL MEASURES IN ACCORDANCE WITH THE "NEW HAMPSHIRE EROSION AND SEDIMENT CONTROL BMP'S" PUBLISHED BY THE NEW HAMPSHIRE D.E.S. IN 2008.



- Position tentacles in a container (or over the MAW), with the threaded connector (open end) facing down, so rinse water is flushed through the membrane and captured in the container.
- Using the Jellyfish rinse tool (available from Contech) or a low-pressure garden hose sprayer, direct water spray onto the tentacle membrane, sweeping from top to bottom along the length of the tentacle. Rinse until all sediment is removed from the membrane. **Caution: Do not use a high pressure sprayer or focused stream of water on the membrane. Excessive water pressure may damage the membrane.**

APPROVED BY THE PORTSMOUTH PLANNING BOARD

CHAIRMAN _____ DATE _____

MIXED USE DEVELOPMENT
581 LAFAYETTE ROAD
PORTSMOUTH, N.H.

NO.	DESCRIPTION	DATE
0	ISSUED FOR COMMENT	11/20/23
REVISIONS		

SCALE: AS NOTED NOVEMBER 2023

JELLYFISH DETAILS

D4

NOTES:

- 1) UNDERGROUND UTILITY LOCATIONS ARE BASED UPON BEST AVAILABLE EVIDENCE AND ARE NOT FIELD VERIFIED. LOCATING AND PROTECTING ANY ABOVEGROUND OR UNDERGROUND UTILITIES IS THE SOLE RESPONSIBILITY OF THE CONTRACTOR AND/OR THE OWNER. UTILITY CONFLICTS SHOULD BE REPORTED AT ONCE TO THE DESIGN ENGINEER.
- 2) THE CONTRACTOR SHALL NOTIFY DIG SAFE AT 1-888-DIG-SAFE (1-888-344-7233) AT LEAST 72 HOURS PRIOR TO COMMENCING ANY EXCAVATION ON PUBLIC OR PRIVATE PROPERTY.
- 3) CONTRACTOR SHALL INSTALL AND MAINTAIN EROSION CONTROL MEASURES IN ACCORDANCE WITH THE "NEW HAMPSHIRE STORMWATER MANUAL, VOLUME 3, EROSION AND SEDIMENT CONTROLS DURING CONSTRUCTION. (NHDES DECEMBER 2008).

MANHOLE NOTES

- 1) IT IS THE INTENTION THAT THE MANHOLE, INCLUDING ALL COMPONENT PARTS, HAVE ADEQUATE SPACE, STRENGTH AND LEAK PROOF QUALITIES CONSIDERED NECESSARY FOR THE INTENDED SERVICE. SPACE REQUIREMENTS AND CONFIGURATIONS, SHALL BE AS SHOWN ON THE DRAWING. MANHOLES SHALL BE AN ASSEMBLY OF PRECAST SECTIONS, WITH STEEL REINFORCEMENT, WITH ADEQUATE JOINTING, OR CONCRETE CAST MONOLITHICALLY IN PLACE WITH REINFORCEMENT. IN ANY APPROVED MANHOLE, THE COMPLETE STRUCTURE SHALL BE OF SUCH MATERIAL AND QUALITY AS TO WITHSTAND LOADS OF 8 TONS (H-20 LOADING) WITHOUT FAILURE AND PREVENT LEAKAGE IN EXCESS OF ONE GALLON PER DAY PER VERTICAL FOOT OF MANHOLE, CONTINUOUSLY FOR THE LIFE OF THE STRUCTURE. A PERIOD GENERALLY IN EXCESS OF 25 YEARS IS TO BE UNDERSTOOD IN BOTH CASES.
- 2) BARRELS AND CONE SECTIONS SHALL BE PRECAST REINFORCED CONCRETE, OR POURED IN PLACE REINFORCED CONCRETE IF POURED AS A COMPLETE MANHOLE.
- 3) PRECAST CONCRETE BARREL SECTIONS, CONES AND BASES SHALL CONFORM TO ASTM C478.
- 4) LEAKAGE TEST MAY NOT BE FEASIBLE, BUT SHALL CONFORM TO ENV-WQ 704.10(X) THROUGH ENV-WQ 704.10(Z).
- 5) INVERTS AND SHELVES: MANHOLES SHALL HAVE A BRICK PAVED SHELF AND INVERT, CONSTRUCTED TO CONFORM TO THE SIZE OF THE PIPE AND FLOW. AT CHANGES IN DIRECTIONS, THE INVERTS SHALL BE LAID OUT IN CURVES OF THE LONGEST RADIUS POSSIBLE AND TANGENT TO THE CENTERLINE OF THE SEWER PIPES. SHELVES SHALL BE CONSTRUCTED TO THE ELEVATION OF THE HIGHEST PIPE CROWN AND SLOPED TO DRAIN TOWARD FLOWING THROUGH CHANNEL. UNDERLAYMENT OF INVERT AND SHELF SHALL CONSIST OF BRICK MASONRY.
- 6) FRAMES AND COVERS: MANHOLE FRAMES AND COVERS SHALL BE OF HEAVY DUTY DESIGN AND PROVIDE A 30-INCH CLEAR OPENING. A THREE INCH (MINIMUM HEIGHT) WORD "SEWER" FOR SEWERS AND "DRAIN" FOR DRAINS SHALL BE PLAINLY CAST INTO THE CENTER OF EACH COVER. CASTINGS SHALL CONFORM TO CLASS 30, ASTM A48.
- 7) BEDDING: SCREENED GRAVEL AND/OR CRUSHED STONE, FREE FROM CLAY, LOAM, ORGANIC MATTER AND MEETING ASTM C33 STONE SIZE NO. 67.

100% PASSING	1 INCH SCREEN
90%-100% PASSING	3/4 INCH SCREEN
20%- 55% PASSING	3/8 INCH SCREEN
0%- 10% PASSING	#4 SIEVE
0%- 5% PASSING	#8 SIEVE

WHEN ORDERED BY THE ENGINEER TO STABILIZE THE BASE, SCREENED GRAVEL OR CRUSHED STONE 1/2 INCH TO 1-1/2 INCH SHALL BE USED.

- 8) FLEXIBLE JOINT: A FLEXIBLE JOINT SHALL BE PROVIDED WITHIN THE FOLLOWING DISTANCES:
RCP & CI PIPE - ALL SIZES - 48"
- 9) SHALLOW MANHOLE: IN LIEU OF A CONE SECTION, WHEN MANHOLE DEPTH IS LESS THAN 6 FEET, A REINFORCED CONCRETE SLAB COVER MAY BE USED HAVING AN ECCENTRIC ENTRANCE OPENING AND CAPABLE OF SUPPORTING H-20 LOADS.
- 10) HORIZONTAL JOINTS BETWEEN SECTIONS OF PRECAST CONCRETE BARRELS SHALL BE OF A TYPE APPROVED BY THE ENGINEER, WHICH TYPE SHALL, IN GENERAL, DEPEND FOR WATER TIGHTNESS UPON AN ELASTOMERIC OR MASTIC-LIKE GASKET, IN 2 ROWS. APPROVED ELASTOMERIC SEALANTS ARE:

RAM-NEK	1 INCH SCREEN
KENT SEAL NO. 2	3/4 INCH SCREEN
EZ	3/8 INCH SCREEN
	#4 SIEVE
	#10 SIEVE

WHEN ORDERED BY THE ENGINEER, OVEREXCAVATE UNSTABLE TRENCH BOTTOM AND BACKFILL WITH CRUSHED STONE.

- 11) LOCATION: THE LOCATION OF THE TEE OR WYE SHALL BE RECORDED AND FILED IN THE MUNICIPAL RECORDS. IN ADDITION, A FERROUS METAL ROD OR PIPE SHALL BE PLACED OVER THE TEE OR WYE AS DESCRIBED IN THE TYPICAL "CHIMNEY" DETAIL, TO AID IN LOCATING THE BURIED PIPE WITH A DIP NEEDLE OR PIPE FINDER.
- 12) CAST-IN-PLACE CONCRETE: SHALL CONFORM TO THE REQUIREMENTS FOR CLASS A (3000 PSI) CONCRETE OF THE NEW HAMPSHIRE DEPARTMENT OF TRANSPORTATION STANDARD SPECIFICATIONS AS FOLLOWS:

CEMENT:	6.0 BAGS PER CUBIC YARD
WATER:	5.75 GALLONS PER BAG OF CEMENT
MAXIMUM AGGREGATE SIZE:	3/4 INCH

- 13) BACKFILL UP TO SUBBASE GRAVEL SHALL BE WITH EXCAVATED SOIL FROM TRENCHING OPERATIONS. COMPACT IN 8" LIFTS WITH VIBRATORY PLATE COMPACTORS TO 90% OF MODIFIED PROCTOR DENSITY. IF FINE-GRAINED, COMPACT WITH POGO STICKS OR SHEEPSFOOT ROLLERS. PLACE NO LARGE ROCKS WITHIN 24" OF PIPE. TRENCHES THAT ARE NOT ADEQUATELY COMPACTED SHALL BE RE-EXCAVATED AND BACKFILLED UNDER THE SUPERVISION OF THE DESIGN ENGINEER OR GOVERNING BODY. UNSUITABLE BACKFILL MATERIAL INCLUDES CHUNKS OF PAVEMENT, TOPSOIL, ROCKS OVER 6" IN SIZE, MUCK, PEAT OR PIECES OF PAVEMENT.
- 14) THE CONTRACTOR IS SOLELY RESPONSIBLE FOR JOB-SITE SAFETY AND COMPLIANCE WITH GOVERNING REGULATIONS.
- 15) ORDERED EXCAVATION OF UNSUITABLE MATERIAL BELOW GRADE. REFILL WITH BEDDING MATERIAL FOR TRENCH WIDTH SEE TRENCH DETAIL.
- 16) SAND BLANKET: CLEAN SAND, FREE FROM ORGANIC MATTER, SO GRADED THAT 90% - 100% PASSES A 1/2 INCH SIEVE AND NOT MORE THAN 15% WILL PASS A #200 SIEVE. BLANKET MAY BE OMITTED FOR DUCTILE IRON AND REINFORCED CONCRETE PIPE PROVIDED THAT NO STONE LARGER THAN 2 INCHES IS IN CONTACT WITH THE PIPE.
- 17) BASE COURSE GRAVEL, IF ORDERED BY THE ENGINEER, SHALL MEET THE REQUIREMENTS OF DIVISION 300 OF THE LATEST EDITION OF THE:

STANDARD SPECIFICATIONS FOR ROAD AND BRIDGE CONSTRUCTION OF THE STATE OF NEW HAMPSHIRE, DEPARTMENT OF TRANSPORTATION.

- 18) IF FULL ENCASEMENT IS UTILIZED, DEPTH OF CONCRETE BELOW PIPE SHALL BE 1/4 I.D. (4" MIN.) BLOCK SUPPORT SHALL BE SOLID CONCRETE BLOCKS.
- 19) THE CONTRACTOR SHALL NOTIFY DIG SAFE AT 1-888-DIG-SAFE (1-888-344-7233) AT LEAST 72 HOURS PRIOR TO COMMENCING ANY EXCAVATION.
- 20) THE PURPOSE OF THIS PLAN IS TO SHOW STANDARDS FOR SEWER CONSTRUCTION.
- 21) ALL WORK SHALL BE IN COMPLIANCE WITH NHDES CODE OF ADMINISTRATIVE RULES PART ENV-WQ 704 DESIGN OF SEWERS.

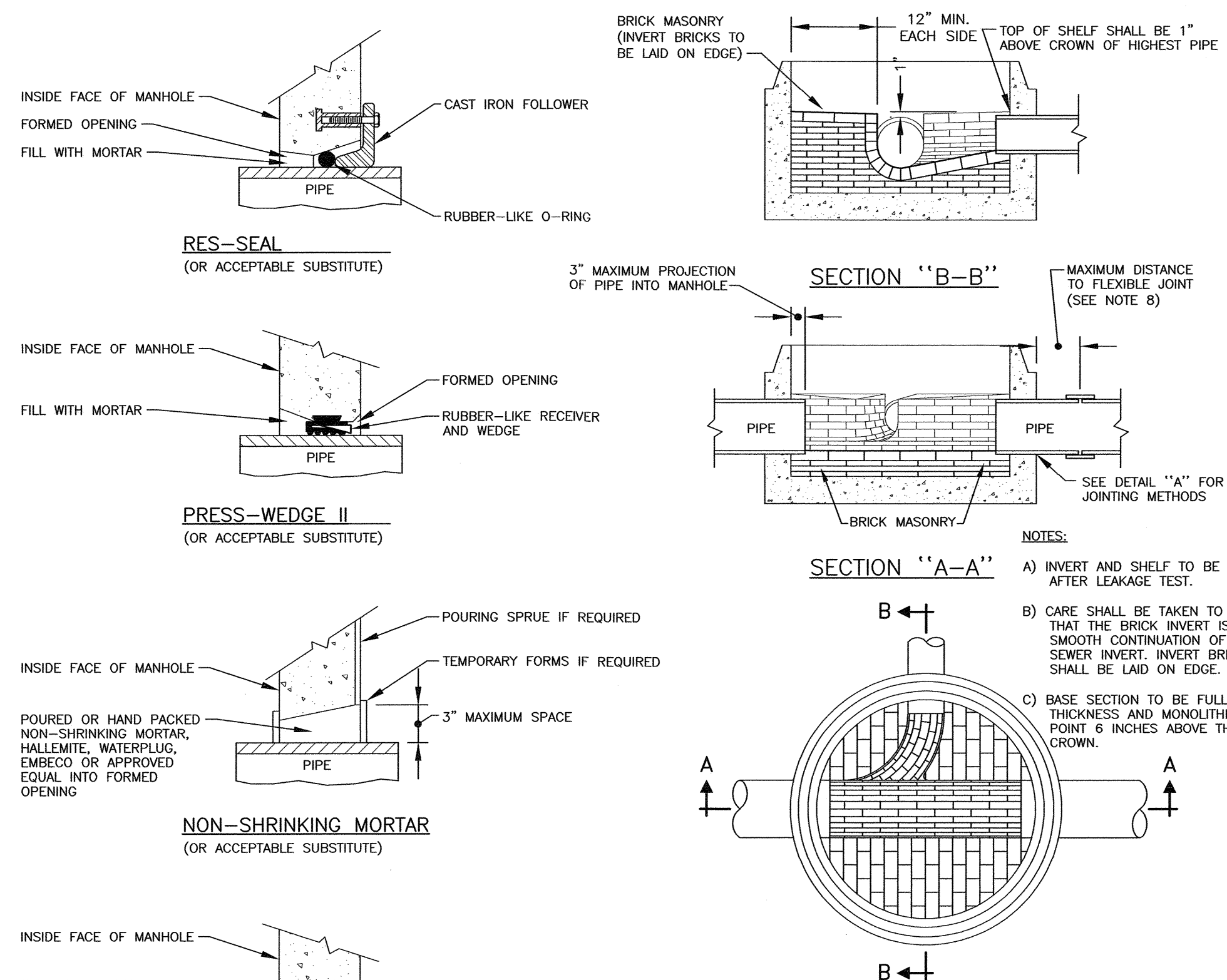

TYPICAL MANHOLE - PLAN VIEW

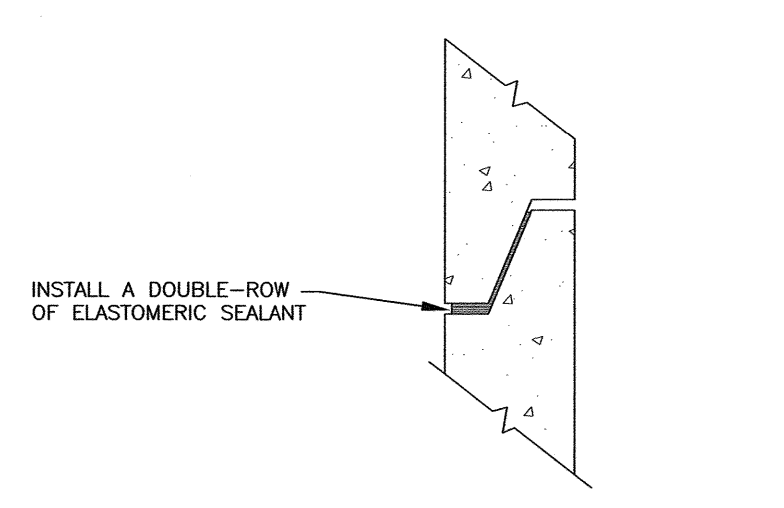

DETAIL "B" - HORIZONTAL JOINTS

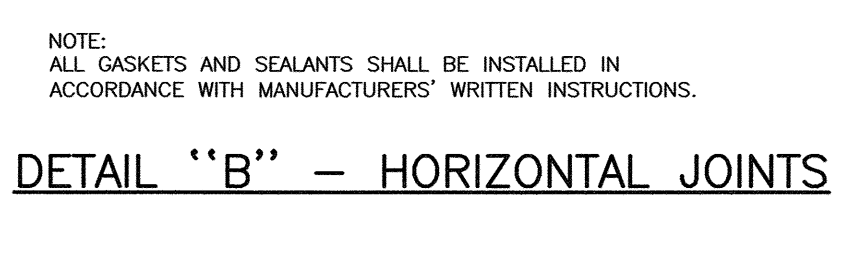

DETAIL "A" - PIPE TO MANHOLE JOINTS

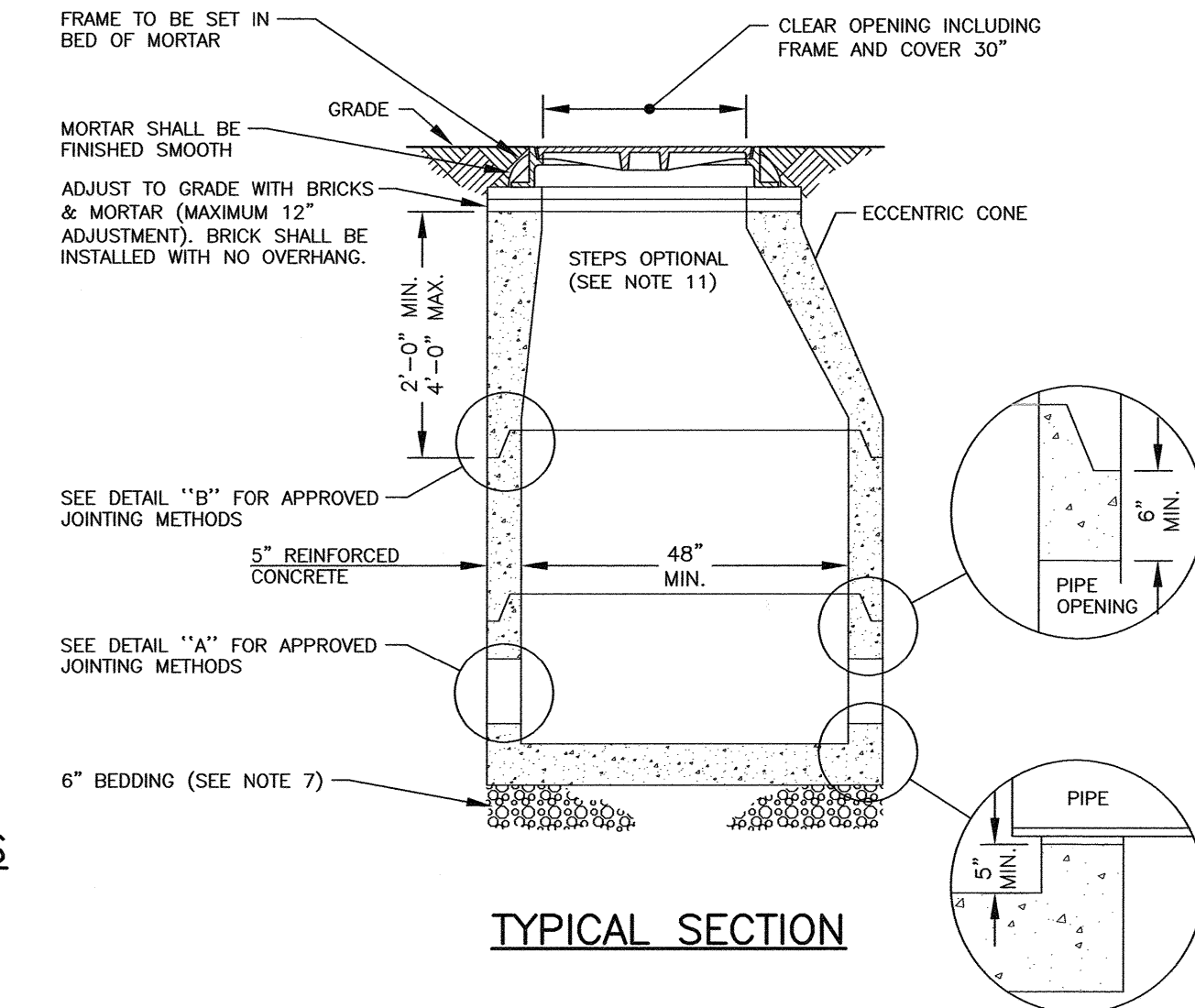
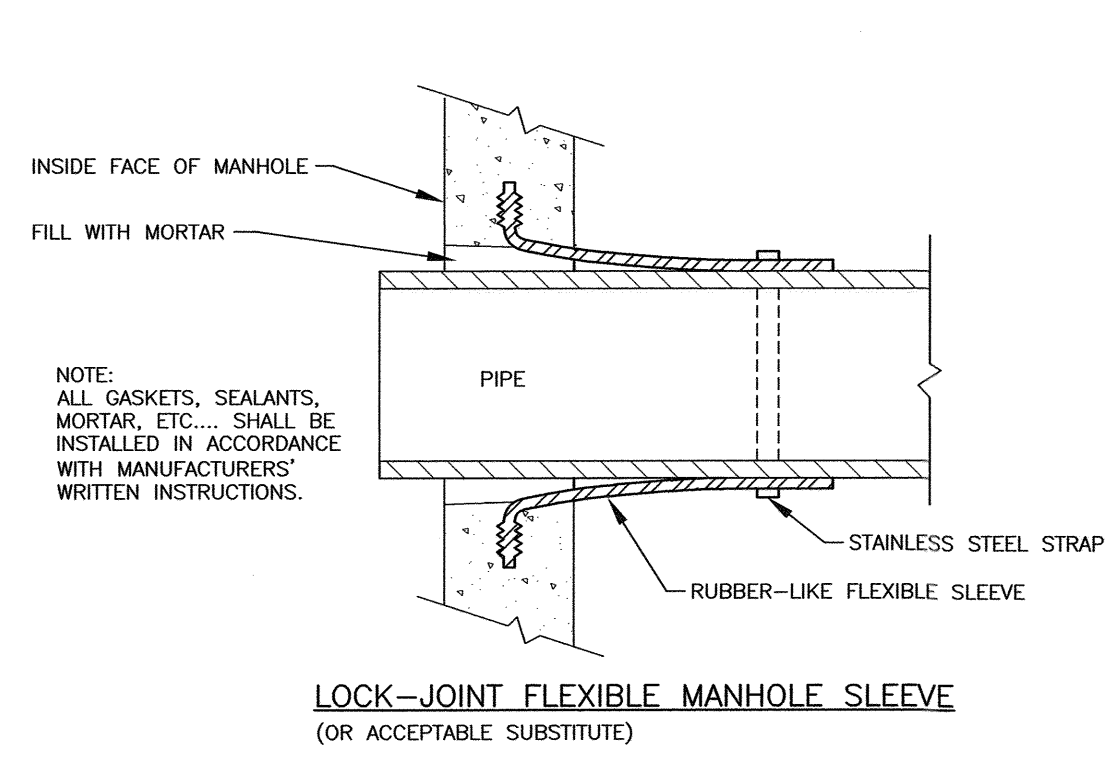

APPROVED BY THE PORTSMOUTH PLANNING BOARD

SEWER MANHOLE DETAILS
INSTALL PER PORTSMOUTH REQUIREMENTS NTS

CHAIRMAN _____ DATE _____

SCALE: AS NOTED NOVEMBER 2023

0	ISSUED FOR COMMENT	11/20/23
NO.	DESCRIPTION	DATE
REVISIONS		

NOTES:

- 1) UNDERGROUND UTILITY LOCATIONS ARE BASED UPON BEST AVAILABLE EVIDENCE AND ARE NOT FIELD VERIFIED. LOCATING AND PROTECTING ANY ABOVEGROUND OR UNDERGROUND UTILITIES IS THE SOLE RESPONSIBILITY OF THE CONTRACTOR AND/OR THE OWNER. UTILITY CONFLICTS SHOULD BE REPORTED AT ONCE TO THE DESIGN ENGINEER.
- 2) THE CONTRACTOR SHALL NOTIFY DIG SAFE AT 1-888-DIG-SAFE (1-888-344-7233) AT LEAST 72 HOURS PRIOR TO COMMENCING ANY EXCAVATION ON PUBLIC OR PRIVATE PROPERTY.
- 3) CONTRACTOR SHALL INSTALL AND MAINTAIN EROSION CONTROL MEASURES IN ACCORDANCE WITH THE "NEW HAMPSHIRE STORMWATER MANUAL, VOLUME 3, EROSION AND SEDIMENT CONTROLS DURING CONSTRUCTION. (NHDES DECEMBER 2008).

APPROVED BY THE PORTSMOUTH PLANNING BOARD

CHAIRMAN _____ DATE _____

MIXED USE DEVELOPMENT
581 LAFAYETTE ROAD
PORTSMOUTH, N.H.

NO.	DESCRIPTION	DATE
2	DETAIL Z	2/21/24
1	DETAIL Y	2/6/24
0	ISSUED FOR COMMENT	1/2/24



SCALE: AS NOTED JANUARY 2024

DETAILS **D6**

GENERAL NOTES:

CONCRETE SPECIFICATIONS:

- 1) 4000 PSI @ 28 DAYS.
- 2) 4%-6% ENTRAINED AIR.
- 3) TANK PENETRATIONS ARE INTEGRALLY CAST.
- 4) ALL JOINTS SEALED WITH BUTYL RESIN.
- 5) EXTERIOR TO BE COATED.

GREASE TRAP INFORMATION:

- 1) TANKS SHOULD BE PUMPED AS NEEDED.
- 2) ACCESS COVERS SHOULD HAVE RISERS TO BRING COVER ACCESS TO GRADE.
- 3) TANKS CAN BE VACUUM TESTED AT AN ADDITIONAL COST.

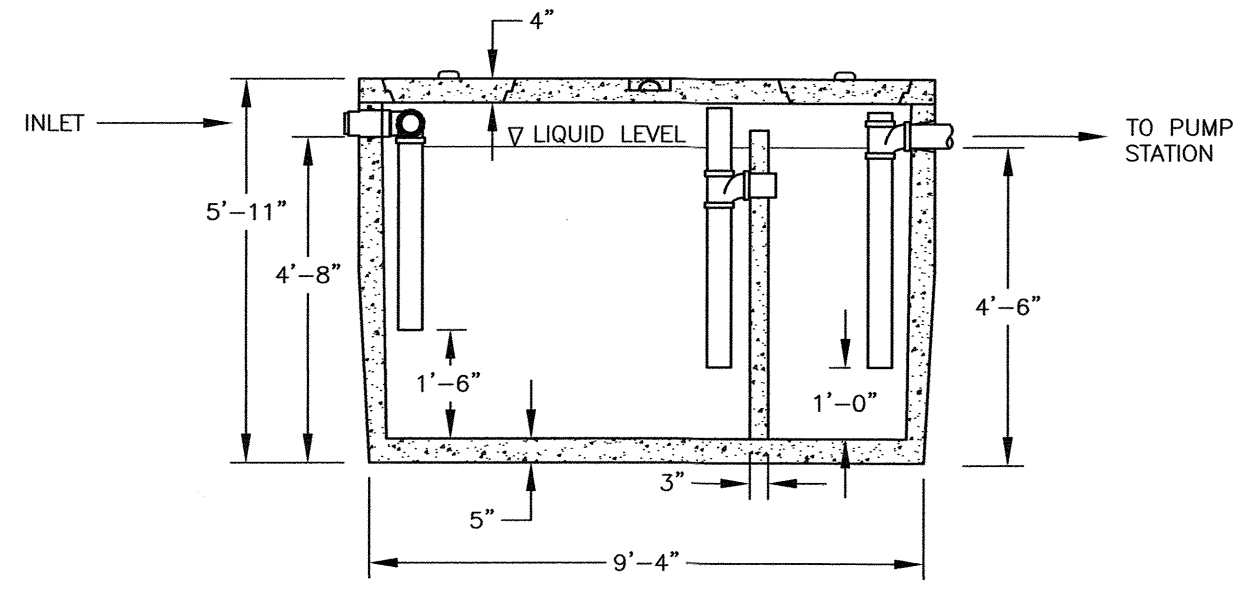
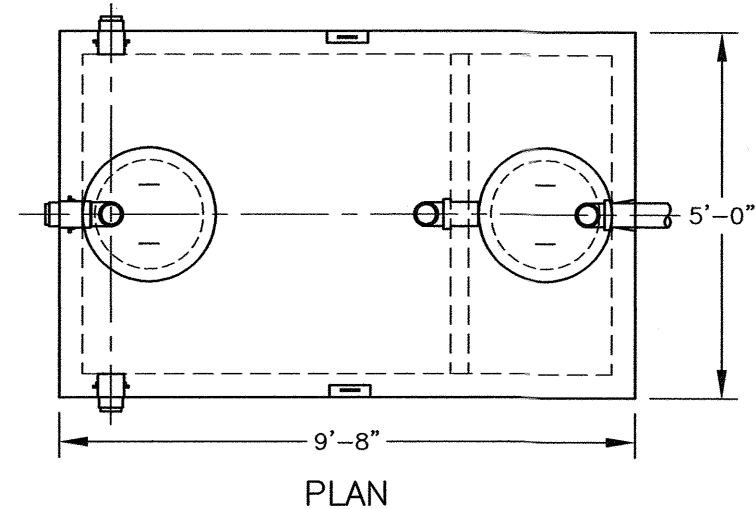

X SHEA CONCRETE
C5 1000 GALLON 2 COMP. GREASE TRAP NTS
14,825 Lbs
ITEM # M1000H
H2O LOAD RATED

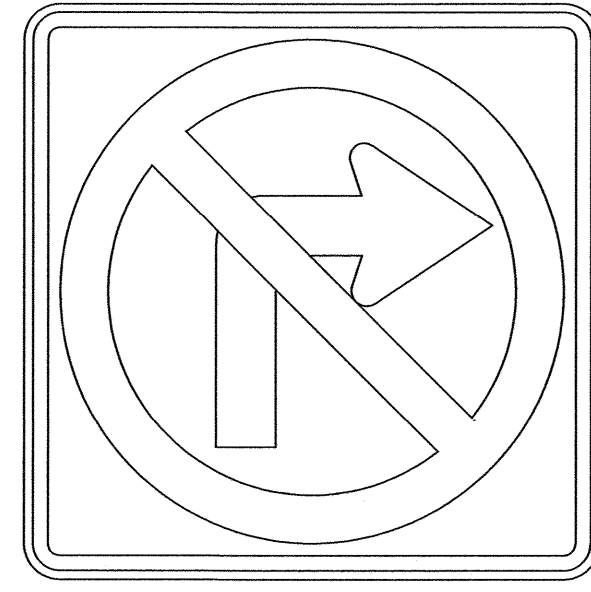

MUTCD R3-1

SIGN TO BE MOUNTED SO BOTTOM EDGE IS NO LESS THAN 7 FEET FROM GROUND SURFACE AND EDGE NEAREST STREET IS NO LESS THAN 2 FEET Laterally FROM EDGE OF PAVEMENT.

Z WALL MOUNTED NO RIGHT
C3 HAND TURN SIGN NTS

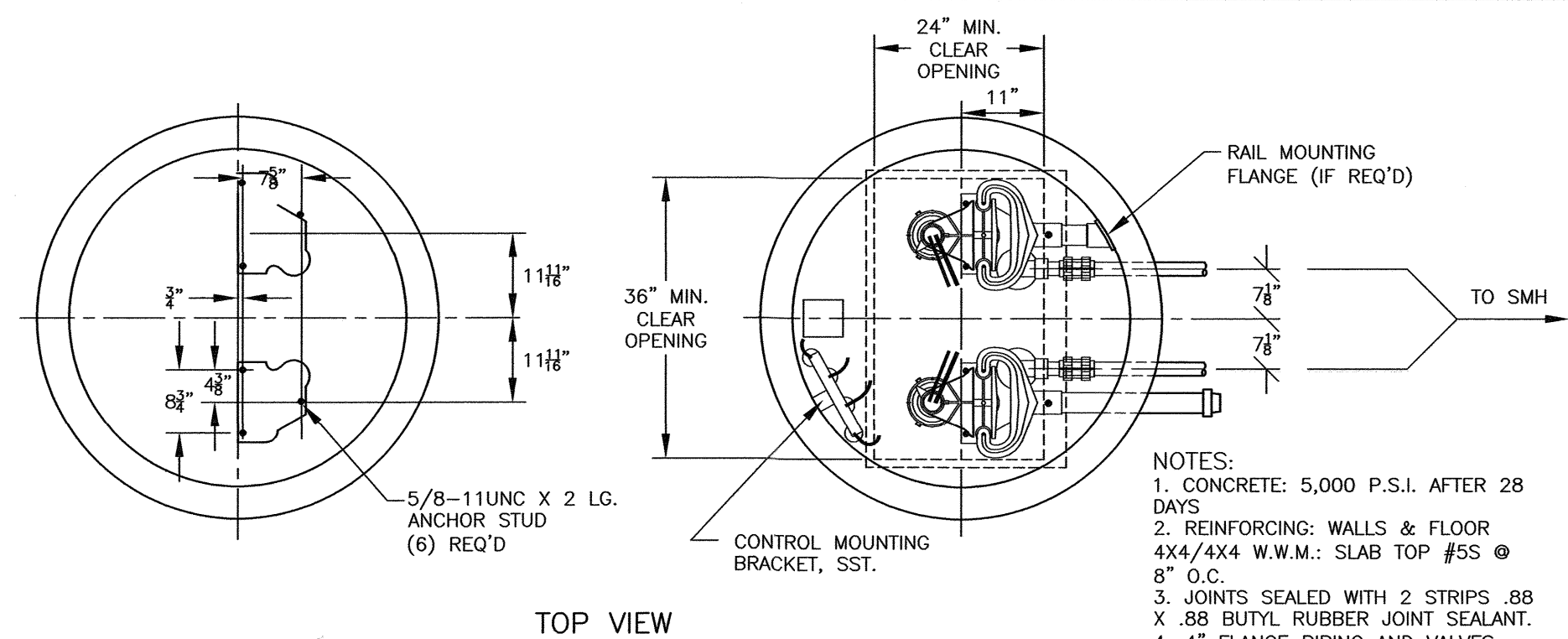

NOTES:

1. CONCRETE: 5,000 P.S.I. AFTER 28 DAYS
2. REINFORCING: WALLS & FLOOR 4X4/4X4 W.W.M.: SLAB TOP #5S @ 8" O.C.
3. JOINTS SEALED WITH 2 STRIPS .88 X .88 BUTYL RUBBER JOINT SEALANT.
4. 4" FLANGE PIPING AND VALVES.
5. PUMPS TO BE GRINDER PUMPS. PUMPS MUST MAINTAIN 3 FT/SEC MIN. VELOCITY IN FORCE MAIN.
6. EMERGENCY PUMP CONNECTION AVAILABLE IN VALVE PIT.
7. PUMP STATION TO BE TESTED FOR WATER TIGHTNESS.

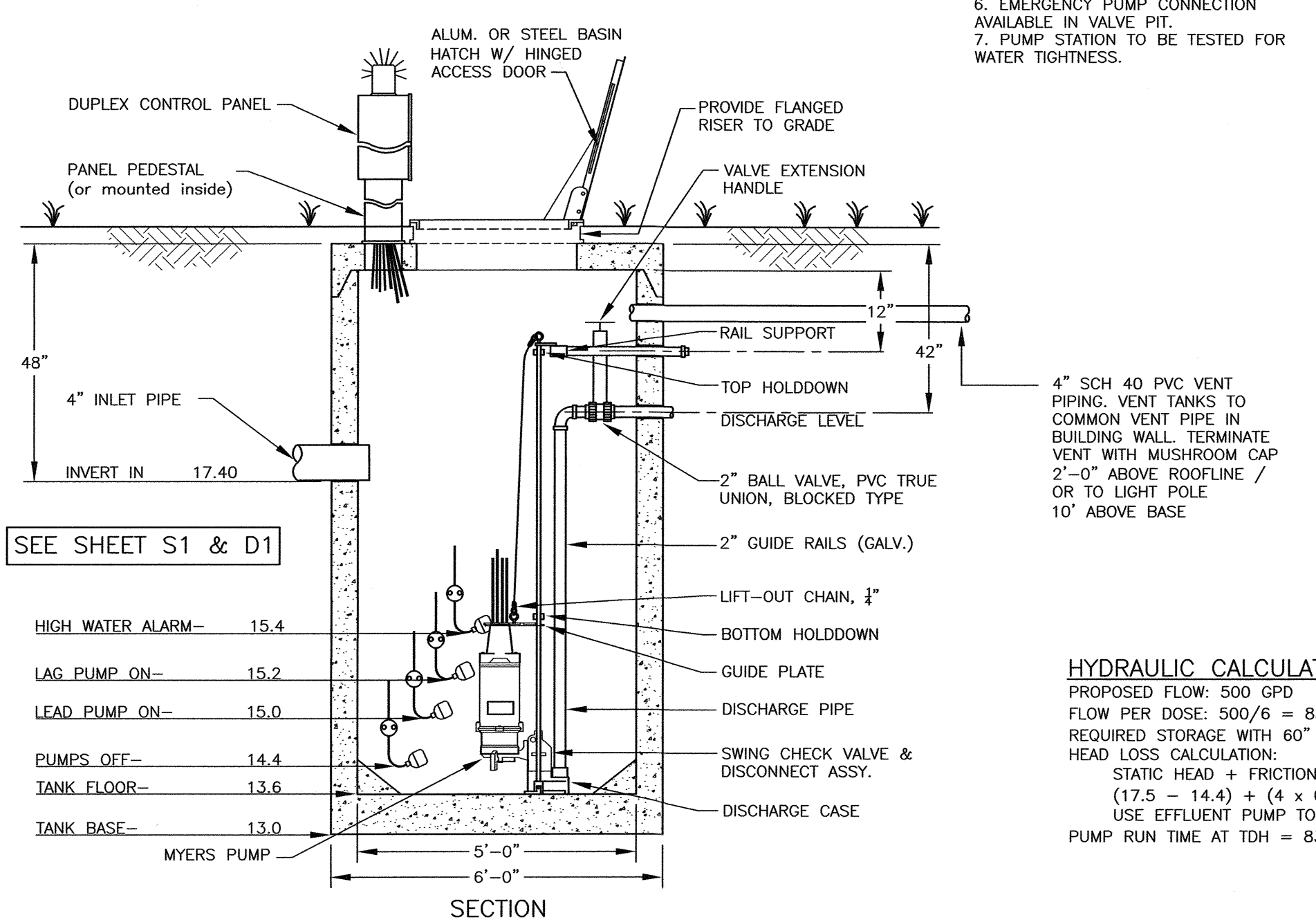

HYDRAULIC CALCULATIONS:

PROPOSED FLOW: 500 GPD
FLOW PER DOSE: 500/6 = 83 GALLONS PER DOSE
REQUIRED STORAGE WITH 60" DIAMETER PUMP STATION: 0.6'

HEAD LOSS CALCULATION:
STATIC HEAD + FRICTION HEAD
(17.5 - 14.4) + (4 x 0.64) = 5.6'
USE EFFLUENT PUMP TO RUN AT 20 GPM
PUMP RUN TIME AT TDH = 83 GAL./20 GPM = 4.1 MINUTES

SEE SHEET S1 & D1

HIGH WATER ALARM	15.4
LAG PUMP ON	15.2
LEAD PUMP ON	15.0
PUMPS OFF	14.4
TANK FLOOR	13.6
TANK BASE	13.0

Y COMMERCIAL EFFLUENT PUMP STATION NTS
C5 OR APPROVED EQUAL



3 CONGRESS ST., SUITE1
 PORTSMOUTH NH 03801
 603.988.0042
 www.ARCove.com

581 Lafayette Road Apartments

581 LAFAYETTE RD
 PORTSMOUTH, NH 03801

PROJECT NO: 1013

OWNER
 ATLAS COMMONS, LLC
 3 PLEASANT STREET, SUITE 400
 PORTSMOUTH, NH 03801
 603.427.0725

CIVIL ENGINEERING
 AMBIT ENGINEERING, A DIVISION OF
 HALEY WARD
 200 GRIFFIN ROAD, UNIT 3
 PORTSMOUTH, NH 03801
 603.430.9282
<https://www.ambitengineering.com/>

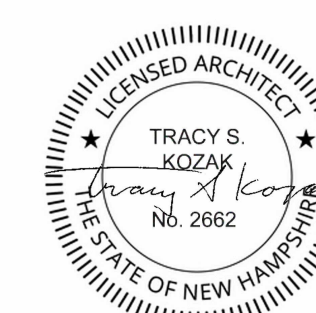

SITE PLAN REVIEW

REVISIONS

NO.	DATE	DESCRIPTION

LEVEL 2 FLOOR PLAN

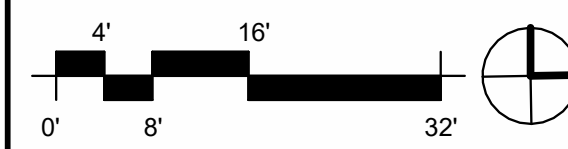

SCALE: 1/16" = 1'-0"

DATE: 2/22/2024

DRAWN: TK/JSV

CHECKED: TK

PB1.02



- 1 BEDROOM
- 2 BEDROOM
- 3 BEDROOM

1 LEVEL 2 - OVERALL PLAN - PB
 1/16" = 1'-0"



3 CONGRESS ST., SUITE 1
 PORTSMOUTH NH 03801
 603.988.0042
 www.ARCove.com

581 Lafayette Road Apartments

581 LAFAYETTE RD
 PORTSMOUTH, NH 03801

PROJECT NO: 1013

OWNER
 ATLAS COMMONS, LLC
 3 PLEASANT STREET, SUITE 400
 PORTSMOUTH, NH 03801
 603.427.0725

CIVIL ENGINEERING
 AMBIT ENGINEERING, A DIVISION OF
 HALEY WARD
 200 GRIFFIN ROAD, UNIT 3
 PORTSMOUTH, NH 03801
 603.430.9282
<https://www.ambitengineering.com/>

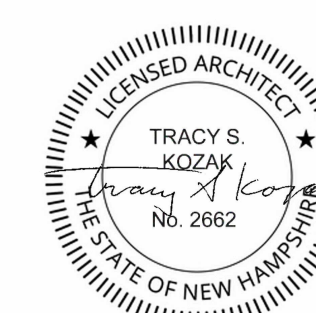

SITE PLAN REVIEW

REVISIONS

NO.	DATE	DESCRIPTION

LEVEL 3 FLOOR PLAN



SCALE: 1/16" = 1'-0"

DATE: 2/22/2024

DRAWN: TK/STV

CHECKED: TK

PB1.03



- 1 BEDROOM
- 2 BEDROOM
- 3 BEDROOM
- STUDIO

1 LEVEL 3 - OVERALL PLAN - PB
 1/16" = 1'-0"



3 CONGRESS ST., SUITE1
 PORTSMOUTH NH 03801
 603.988.0042
 www.ARCove.com

581 Lafayette Road Apartments

581 LAFAYETTE RD
 PORTSMOUTH, NH, 03801

PROJECT NO: 1013

OWNER
 ATLAS COMMONS, LLC
 3 PLEASANT STREET, SUITE 400
 PORTSMOUTH, NH 03801
 603.427.0725

CIVIL ENGINEERING
 AMBIT ENGINEERING, A DIVISION OF
 HALEY WARD
 200 GRIFFIN ROAD, UNIT 3
 PORTSMOUTH, NH 03801
 603.430.9282
<https://www.ambitengineering.com/>

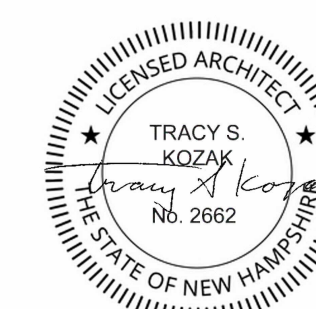

SITE PLAN REVIEW

REVISIONS

NO.	DATE	DESCRIPTION

LEVEL 4 FLOOR PLAN

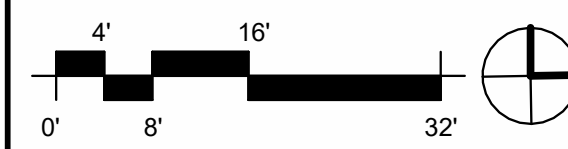

SCALE: 1/16" = 1'-0"

DATE: 2/22/2024

DRAWN: TK/STV

CHECKED: TK

PB1.04



- 1 BEDROOM
- 2 BEDROOM
- 3 BEDROOM
- STUDIO

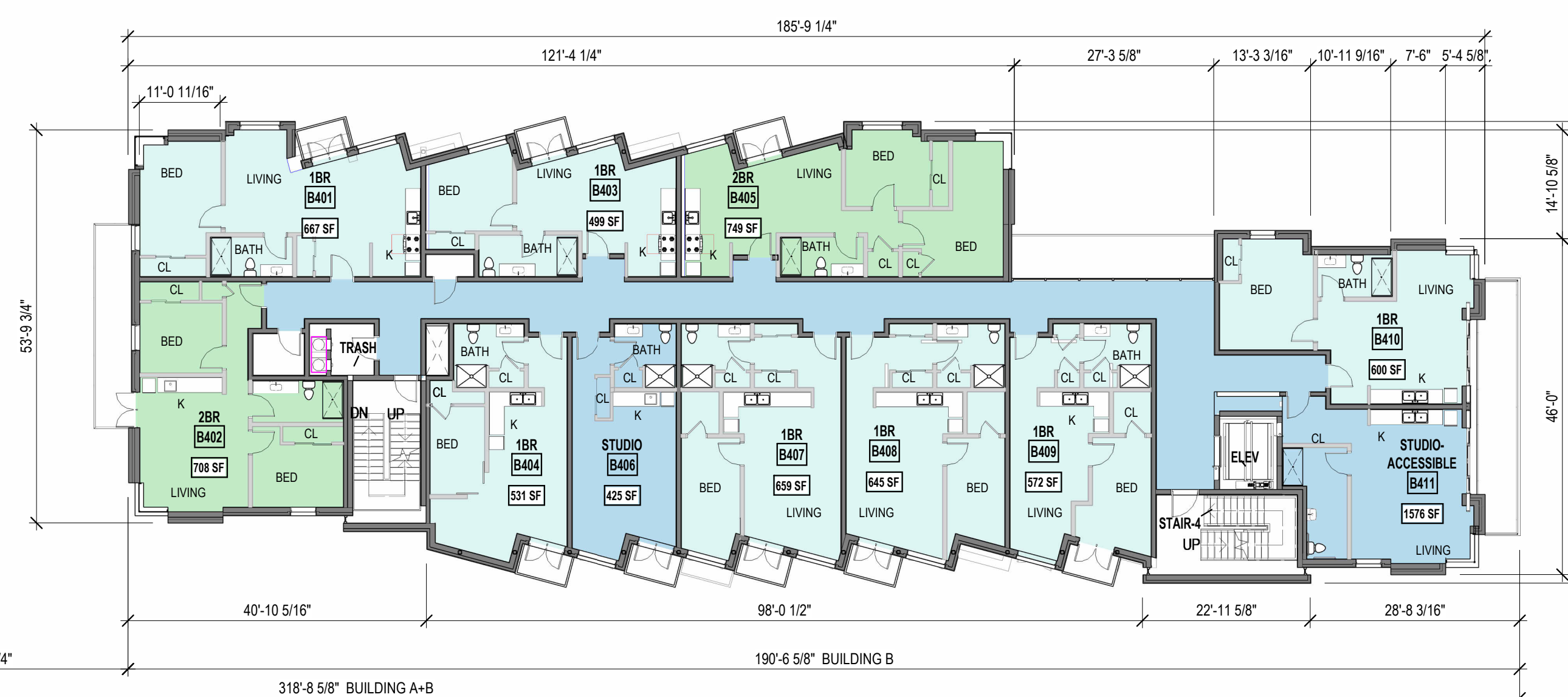

1 LEVEL 4 - OVERALL PLAN - PB
 1/16" = 1'-0"



3 CONGRESS ST., SUITE 1
 PORTSMOUTH NH 03801
 603.988.0042
 www.ARCove.com

581 Lafayette Road Apartments

581 LAFAYETTE RD
 PORTSMOUTH, NH, 03801

PROJECT NO: 1013

OWNER
 ATLAS COMMONS, LLC
 3 PLEASANT STREET, SUITE 400
 PORTSMOUTH, NH 03801
 603.427.0725

CIVIL ENGINEERING
 AMBIT ENGINEERING, A DIVISION OF
 HALEY WARD
 200 GRIFFIN ROAD, UNIT 3
 PORTSMOUTH, NH 03801
 603.430.9282
<https://www.ambitengineering.com/>

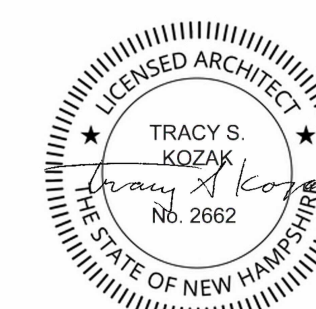

SITE PLAN REVIEW

REVISIONS

NO.	DATE	DESCRIPTION

LEVEL 5 FLOOR PLAN

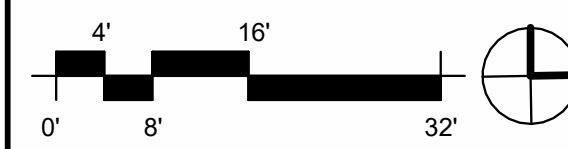

SCALE: 1/16" = 1'-0"

DATE: 2/22/2024
 DRAWN: TK/STV
 CHECKED: TK

PB1.05



- 1 BEDROOM
- 2 BEDROOM
- 3 BEDROOM
- STUDIO

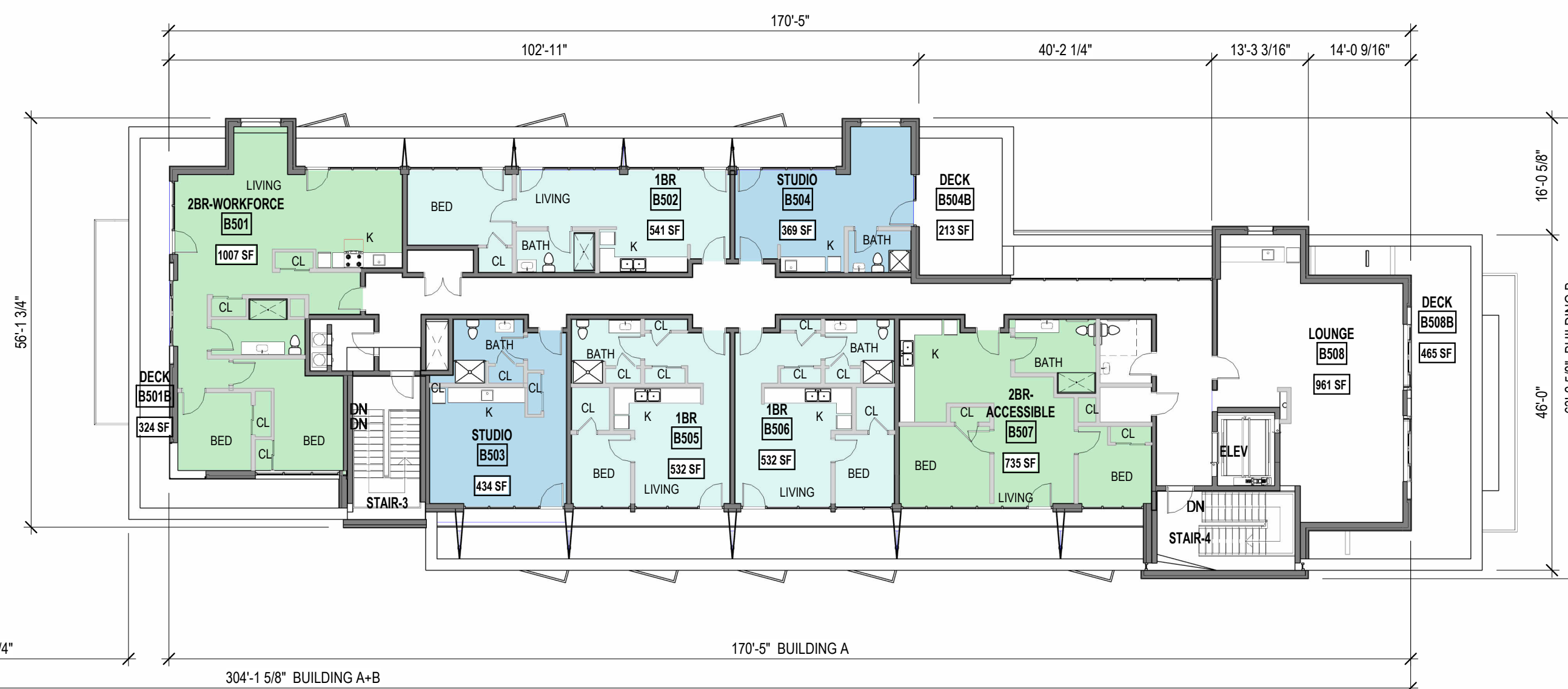

1 LEVEL 5 - OVERALL PLAN - PB
 1/16" = 1'-0"



3 CONGRESS ST., SUITE1
 PORTSMOUTH NH 03801
 603.988.0042
 www.ARCOVE.com

581 Lafayette Road Apartments

581 LAFAYETTE RD
 PORTSMOUTH, NH, 03801

PROJECT NO: 1013

OWNER
 ATLAS COMMONS, LLC
 3 PLEASANT STREET, SUITE 400
 PORTSMOUTH, NH 03801
 603.427.0725

CIVIL ENGINEERING
 AMBIT ENGINEERING, A DIVISION OF
 HALEY WARD
 200 GRIFFIN ROAD, UNIT 3
 PORTSMOUTH, NH 03801
 603.430.9282
<https://www.ambitengineering.com/>

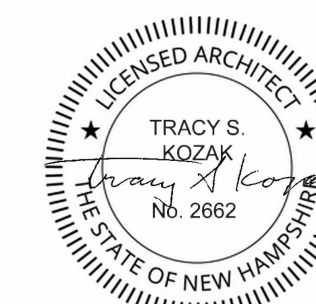

SITE PLAN REVIEW

REVISIONS

NO.	DATE	DESCRIPTION

ELEVATIONS

SCALE: 1/16" = 1'-0"
 DATE: 2/22/2024
 DRAWN:
 CHECKED:

PB2.01

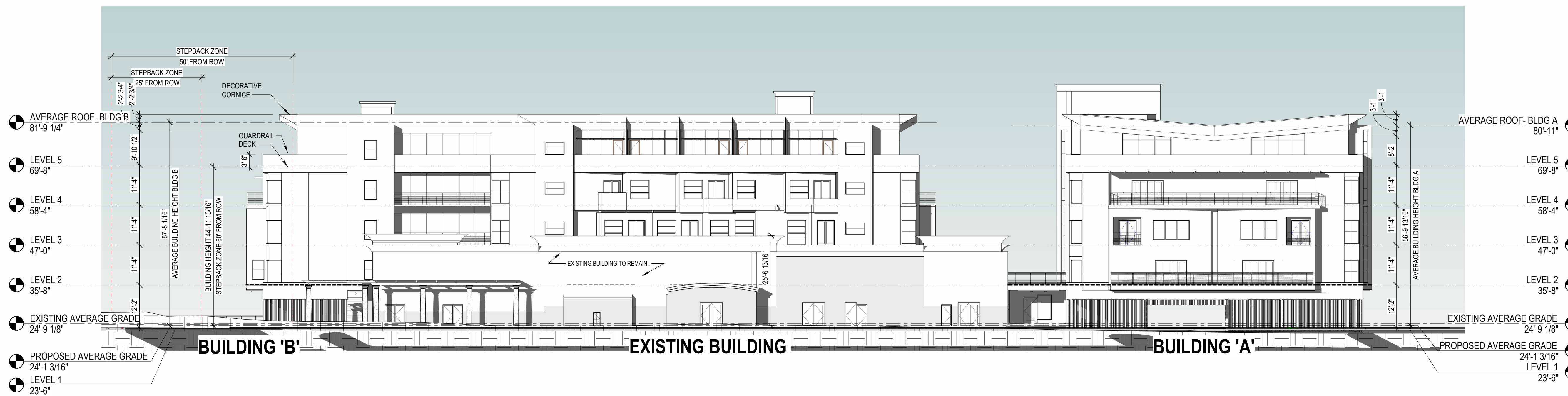

2 WEST ELEVATION PB
 1/16" = 1'-0"

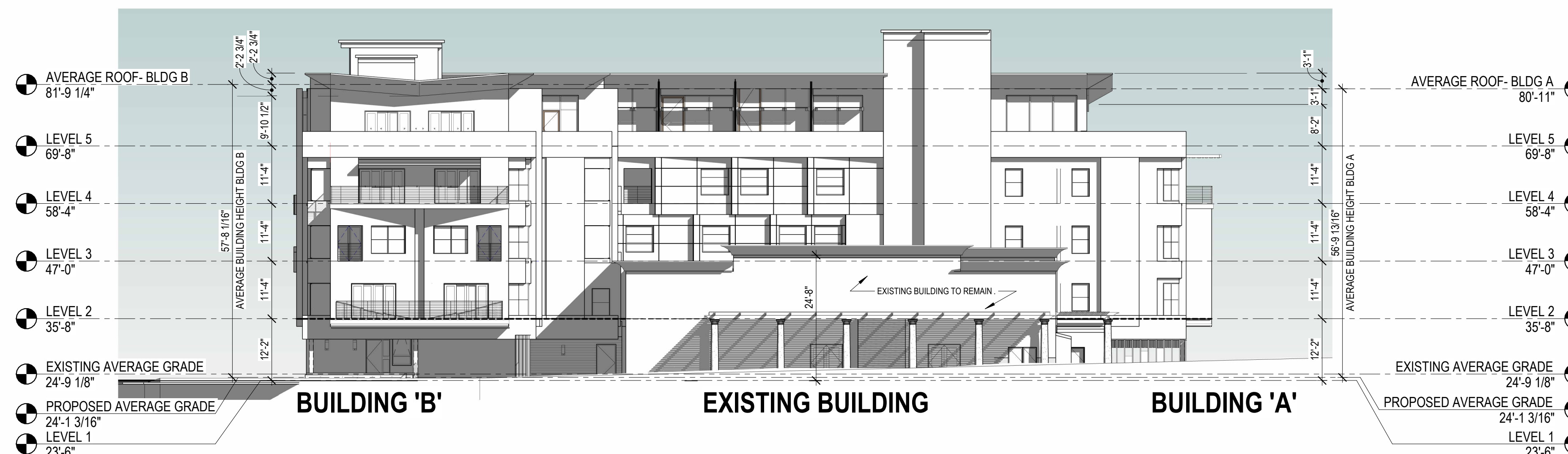

1 NORTH ELEVATION PB
 1/16" = 1'-0"



3 CONGRESS ST., SUITE 1
 PORTSMOUTH NH 03801
 603.988.0042
 www.ARCOVE.com

581 Lafayette Road Apartments

581 LAFAYETTE RD
 PORTSMOUTH, NH 03801

PROJECT NO: 1013

OWNER
 ATLAS COMMONS, LLC
 3 PLEASANT STREET, SUITE 400
 PORTSMOUTH, NH 03801
 603.427.0725

CIVIL ENGINEERING
 AMBIT ENGINEERING, A DIVISION OF
 HALEY WARD
 200 GRIFFIN ROAD, UNIT 3
 PORTSMOUTH, NH 03801
 603.430.9282
<https://www.ambitengineering.com/>

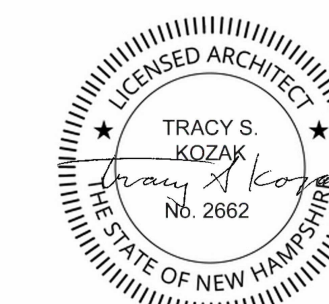

SITE PLAN REVIEW

REVISIONS

NO.	DATE	DESCRIPTION

ELEVATIONS

SCALE: 1/16" = 1'-0"
 DATE: 2/22/2024
 DRAWN: Author
 CHECKED: Checker

PB2.02

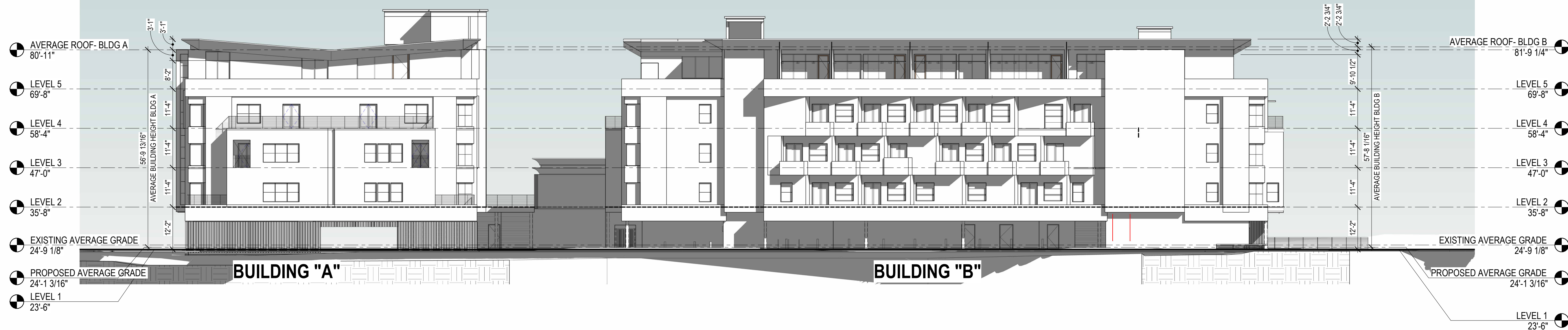

2 EAST ELEVATION PB
 1/16" = 1'-0"

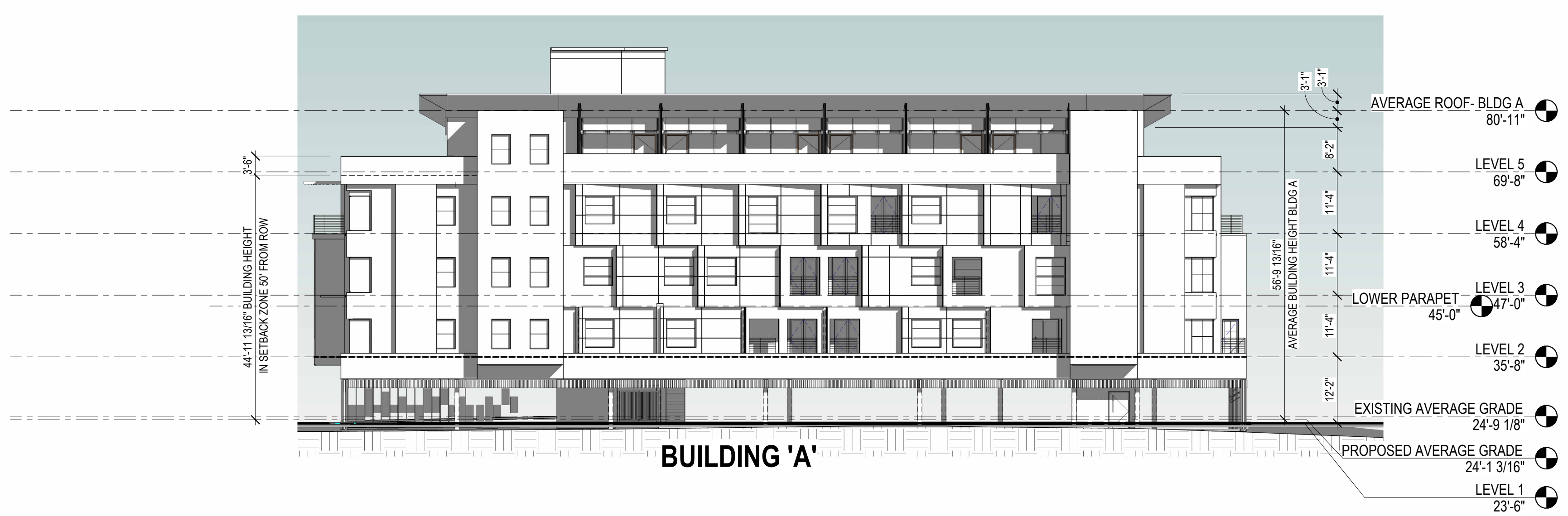

1 SOUTH ELEVATION PB
 1/16" = 1'-0"



3 CONGRESS ST., SUITE1
 PORTSMOUTH NH 03801
 603.988.0042
 www.ARCove.com

581 Lafayette Road Apartments

581 LAFAYETTE RD
 PORTSMOUTH, NH, 03801

PROJECT NO: 1013

OWNER
 ATLAS COMMONS, LLC
 3 PLEASANT STREET, SUITE 400
 PORTSMOUTH, NH 03801
 603.427.0725

CIVIL ENGINEERING
 AMBIT ENGINEERING, A DIVISION OF
 HALEY WARD
 200 GRIFFIN ROAD, UNIT 3
 PORTSMOUTH, NH 03801
 603.430.9282
<https://www.ambitengineering.com/>

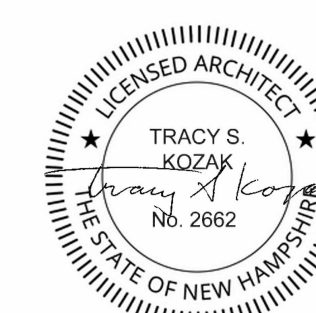

SITE PLAN REVIEW

REVISIONS

NO.	DATE	DESCRIPTION

RENDERING

SCALE: 3/4" = 1'-0"

DATE: 2/22/2024

DRAWN: Author

CHECKED: Checker

PB3.01



2 PERSPECTIVE FROM NW
 3/4" = 1'-0"

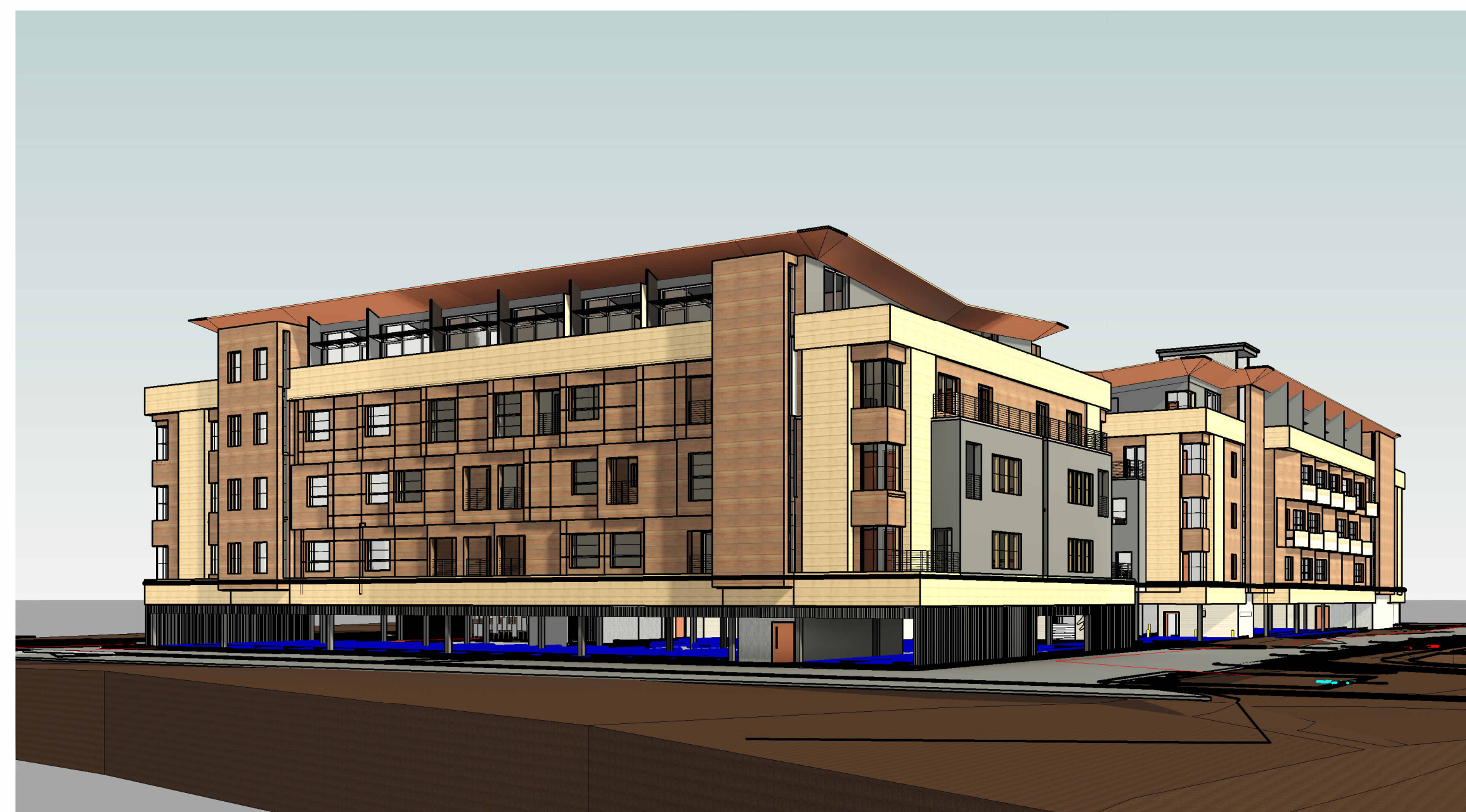

3 PERSPECTIVE FROM SE



1 PERSPECTIVE FROM SW