

# PROPOSED SITE DEVELOPMENT

## 46-64 MAPLEWOOD AVENUE

PORTSMOUTH, NEW HAMPSHIRE

## PERMIT SITE PLANS

REQUIRED STATE AND FEDERAL PERMITS  
NHDES SEWER DISCHARGE: TO BE SUBMITTED

**OWNER:**

30 MAPLEWOOD, LLC  
30 MAPLEWOOD AVENUE  
PORTSMOUTH, N.H. 03801  
Tel (603) 766-3760  
Fax (603) 766-3761

**LAND SURVEYOR & ENGINEER:**  
**AMBIT ENGINEERING, INC.**

200 GRIFFIN ROAD, UNIT 3  
PORTSMOUTH, N.H. 03801-7114  
Tel (603) 430-9282  
Fax (603) 436-2315

**BUILDING DESIGN:**  
**SOMMA STUDIOS**

30 MAPLEWOOD AVENUE  
PORTSMOUTH, N.H. 03801  
Tel (617) 766-3760  
Fax (617) 766-3761

**LIGHTING CONSULTING:**  
**VISIBLE LIGHT INC.**

24 STICKNEY TERRACE, SUITE 6  
HAMPTON, N.H. 03842  
Tel (603) 926-6049  
Fax (603) 926-6708

**LANDSCAPE ARCHITECT:**  
**WOODBURN & COMPANY LANDSCAPE ARCHITECTURE, LLC**

103 KENT PLACE  
NEWMARKET, N.H. 03857  
Tel (603) 659-5949  
Fax (603) 659-5939



**PORTSMOUTH APPROVAL CONDITIONS NOTE:**  
ALL CONDITIONS ON THIS PLAN SET SHALL REMAIN IN EFFECT IN PERPETUITY PURSUANT TO THE REQUIREMENTS OF THE CITY OF PORTSMOUTH SITE PLAN REVIEW REGULATIONS.

APPROVED BY THE PORTSMOUTH PLANNING BOARD

CHAIRMAN \_\_\_\_\_ DATE \_\_\_\_\_

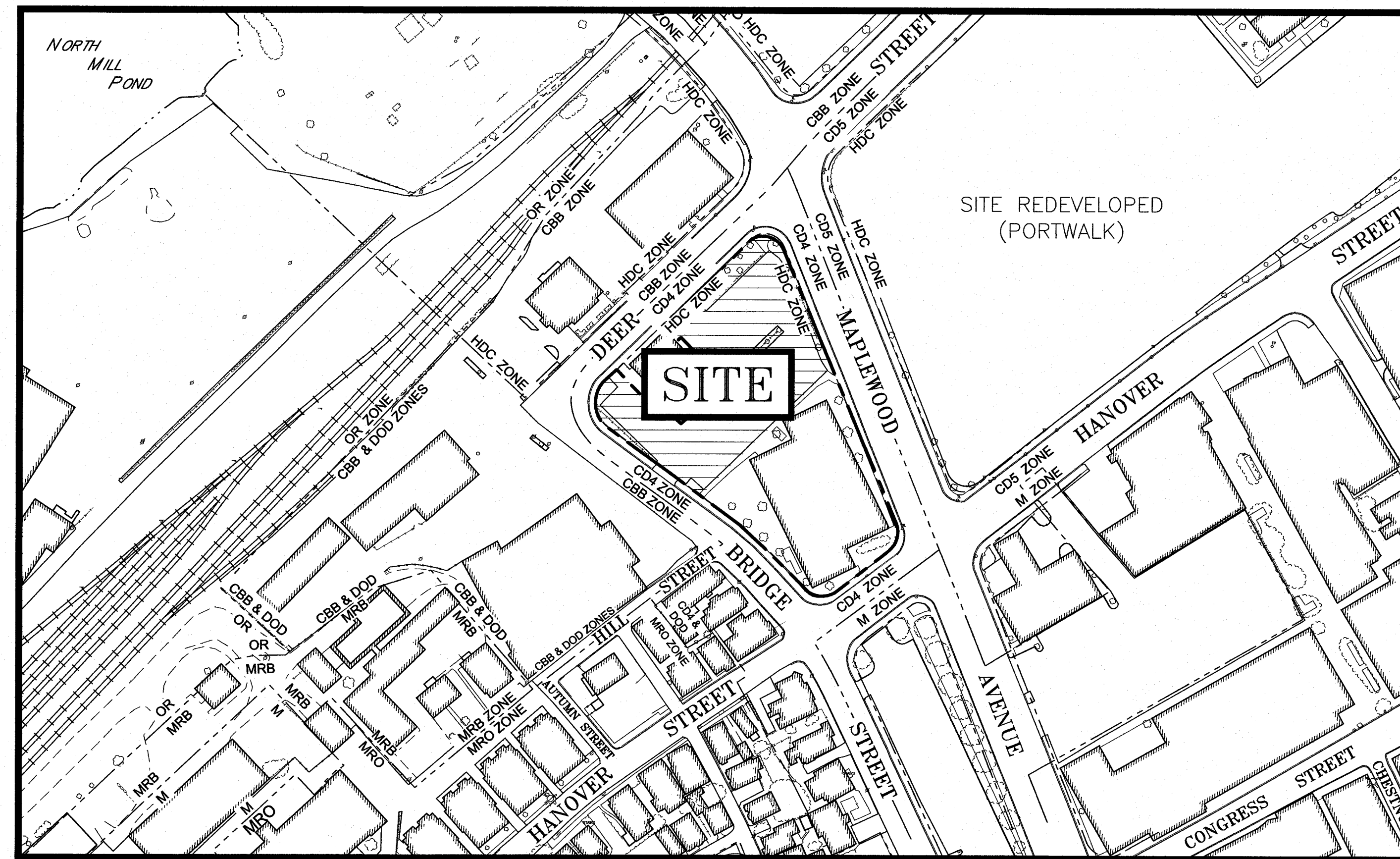

**LOCUS MAP**

SCALE: 1" = 100'

ZONING AS OF 2013

**INDEX OF SHEETS**

- EASEMENT AND LICENSE PLAN
- C1 - EXISTING CONDITIONS PLAN
- C2 - DEMOLITION PLAN
- LANDSCAPE PLANS L-1 TO L-3
- C3 - SITE PLAN, 1st FLOOR LEVEL
- C4 - SITE PLAN, BASEMENT LEVEL
- C5 - UTILITY PLAN
- C6 - GRADING AND DRAINAGE PLAN
- P1 - GARAGE RAMP PROFILE
- L1 - LIGHTING PLAN
- D1-D5 - DETAILS
- ARCHITECTURAL ELEVATIONS

**UTILITY CONTACTS**

**ELECTRIC:**  
EVERSOURCE  
1700 LAFAYETTE ROAD  
PORTSMOUTH, N.H. 03801  
Tel. (603) 436-7708, Ext. 555.5678  
ATTN: MICHAEL BUSBY, P.E. (MANAGER)  
MICHAEL.BUSBY@NU.COM

**NATURAL GAS:**  
UNITIL  
325 WEST ROAD  
PORTSMOUTH, N.H. 03801  
Tel. (603) 294-5144  
ATTN: DAVE BEAULIEU

**CABLE:**  
COMCAST  
155 COMMERCE WAY  
PORTSMOUTH, N.H. 03801  
Tel. (603) 679-5695 (X1037)  
ATTN: MIKE COLLINS

**SEWER & WATER:**  
PORTSMOUTH DEPARTMENT OF PUBLIC WORKS  
680 PEVERLY HILL ROAD  
PORTSMOUTH, N.H. 03801  
Tel. (603) 427-1530  
ATTN: JOHN ADAMS (SEWER)  
ATTN: TERRY DESMARIS (WATER)

**COMMUNICATIONS:**  
FAIRPOINT COMMUNICATIONS  
JOE CONSIDINE  
1575 GREENLAND ROAD  
GREENLAND, N.H. 03840  
Tel. (603) 427-5525

**LEGEND:**

EXISTING	PROPOSED	
---	---	PROPERTY LINE
---	---	SETBACK
S	S	SEWER PIPE
SL	SL	SEWER LATERAL
G	G	GAS LINE
D	D	STORM DRAIN
W	W	WATER LINE
WS	WS	WATER SERVICE
UGE	UGE	UNDERGROUND ELECTRIC
OHW	OHW	OVERHEAD ELECTRIC/WIRES
	UD	FOUNDATION DRAIN
		EDGE OF PAVEMENT (EP)
100	100	CONTOUR
97x3	98x0	SPOT ELEVATION
		UTILITY POLE
		WALL MOUNTED EXTERIOR LIGHTS
		TRANSFORMER ON CONCRETE PAD
		SHUT OFFS (WATER/GAS)
		GATE VALVE
		HYDRANT
		CATCH BASIN
		SEWER MANHOLE
		DRAIN MANHOLE
		TELEPHONE MANHOLE
		PARKING SPACE COUNT
		PARKING METER
		LANDSCAPED AREA
LSA		LANDSCAPED AREA
TBD	TBD	TO BE DETERMINED
CI	CI	CAST IRON PIPE
COP	COP	COPPER PIPE
DI	DI	DUCTILE IRON PIPE
PVC	PVC	POLYVINYL CHLORIDE PIPE
RCP	RCP	REINFORCED CONCRETE PIPE
AC		ASBESTOS CEMENT PIPE
VC	VC	VITRIFIED CLAY PIPE
EP	EP	EDGE OF PAVEMENT
EL	EL	ELEVATION
FF	FF	FINISHED FLOOR
INV	INV	INVERT
S =	S =	SLOPE FT/FT
TBM	TBM	TEMPORARY BENCH MARK
TYP	TYP	TYPICAL

**PROPOSED SITE DEVELOPMENT**  
46-64 MAPLEWOOD AVENUE  
PORTSMOUTH, N.H.

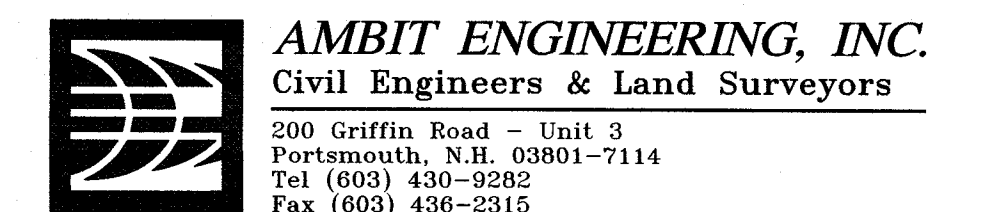

PLAN SET ISSUED: 12 JANUARY 2018

**NOTES:**

- 1) PARCELS ARE SHOWN ON THE CITY OF PORTSMOUTH ASSESSORS MAP 125 AS LOTS 2 & 2A.
- 2) OWNERS OF RECORD:  
 125/2:  
 30 MAPLEWOOD AVENUE  
 CONDOMINIUM ASSOCIATION  
 36 MAPLEWOOD AVENUE  
 PORTSMOUTH, N.H. 03801  
 5099/2424  
 PLAN D-38936  
 DECLARATION: BK 5636, BK 1930  
 FIRST AMENDMENT: BK 5647, PG 1038  
 SECOND AMENDMENT: BK 5688, PG 2226  
 THIRD AMENDMENT: BK 5783 PG 2443  
 FOURTH AMENDMENT: BK 5807, PG 2635  
 FIFTH AMENDMENT: BK 5835/ PG 1026  
 125/2A  
 30 MAPLEWOOD LLC  
 36 MAPLEWOOD AVENUE  
 PORTSMOUTH, N.H. 03801  
 5835/1026
- 3) PARCEL IS NOT IN A FLOOD HAZARD ZONE AS SHOWN ON FIRM PANEL 33015C0259E, MAY 17, 2005.
- 4) EXISTING LOT AREAS:  

LOT 1	LOT 2
34,887 S.F.	21,798 S.F.
0.8009 AC.	0.5004 AC.
- 5) PARCELS ARE CURRENTLY LOCATED IN THE CHARACTER DISTRICT 4-L, HISTORIC DISTRICT, AND DOWNTOWN OVERLAY DISTRICT.
- 6) THE PURPOSE OF THIS PLAN IS TO SHOW THE LOCATION OF PROPOSED EASEMENTS AND LICENSES.
- 7) PARCELS ARE SUBJECT TO:  
 AN EASEMENT TO EVERSOURCE (PUBLIC SERVICE COMPANY OF N.H.) RECORDED AT RCRD 5516/946 (SEE D-38148)  
 AN EASEMENT TO THE CITY OF PORTSMOUTH AT RCRD 5512/1047. NOTE: INFRASTRUCTURE RELOCATED TO EVERSOURCE EASEMENT AREA.
- 8) LOT 2A HAS A DEEDED RIGHT TO USE THE DUMPSTER ON LOT 2. SEE RCRD 5835/1026
- 9) PER MUTUAL EASEMENT DEED BETWEEN LOT 1 AND LOT 2 THE CONSTRUCTION AND MAINTENANCE OF THIS DRAINAGE SYSTEM WILL BE THE RESPONSIBILITY OF 46 MAPLEWOOD AVENUE CONDOMINIUM ASSOCIATION.

NO.	DESCRIPTION	DATE
1	ADDED HATCHING	1/12/18
0	ISSUED FOR COMMENT	12/19/17

**EASEMENT AND LICENSE PLAN**  
**TAX MAP 125-LOTS 2 & 2A**  
**(SUBDIVISION LOTS 1 & 2)**  
 OWNER:  
**30 MAPLEWOOD, LLC**  
 30-64 MAPLEWOOD AVENUE  
 CITY OF PORTSMOUTH  
 COUNTY OF ROCKINGHAM  
 STATE OF NEW HAMPSHIRE

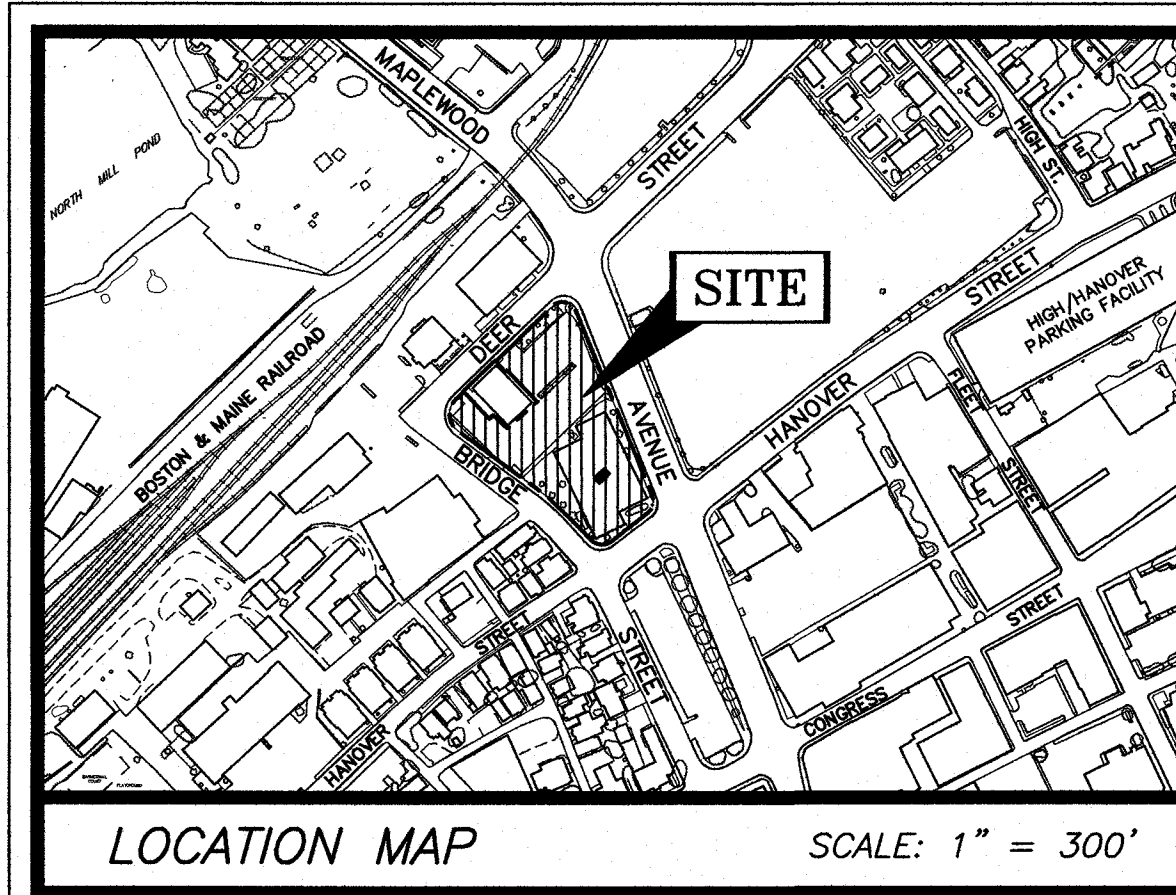

- LEGEND:**
- LCA LIMITED COMMON AREA
  - N/F NOW OR FORMERLY
  - RP RECORD OF PROBATE
  - RCRD ROCKINGHAM COUNTY REGISTRY OF DEEDS
  - RR SPK RAILROAD SPIKE
  - MAP 11/LOT 21
  - IR FND IRON ROD FOUND
  - IP FND IRON PIPE FOUND
  - IR SET IRON ROD SET
  - RR SPK SET RAILROAD SPIKE SET
  - DH FND DRILL HOLE FOUND
  - DH SET DRILL HOLE SET
  - BND w/DH BOUND WITH DRILL HOLE
  - ST BND w/DH STONE BOUND WITH DRILL HOLE
  - 1 A REFERENCE TO FIFTH AMENDMENT TO BE RECORDED (HEREWITH)
  - 10 PARKING COUNT (10)

**ABUTTERS LIST:**

- 125 1 N/F PARADE OFFICE c/o CATHARTIS PRIVATE INVESTMENTS 262 WASHINGTON STREET, SUITE 302 BOSTON, MA 02108 3756 / 2701
- 125 3 N/F EMERSON HOVEY POST 168 VFW 238 DEER STREET PORTSMOUTH, N.H. 03801
- 125 4 N/F SHIANG TA CHEN & JUNE LI 60 NORTON ROAD QUINCY, MA 02169 3280 / 0645
- 125 5 N/F CINDY LEE CARROLL 391 MILLER AVENUE PORTSMOUTH, N.H. 03801 3103 / 0287
- 125 6 N/F G AND N REALTY, LLC 30074 VILLAGE PARK DRIVE CHAPEL HILL, NC 27517 3957 / 2586
- 125 16 N/F JOHN GRAY REVOC. TRUST BRADFORD A GRAY REVOC. TRUST 7 PATRIOTS WAY RYE, N.H. 03870 3895 / 0643
- 125 17 N/F DEER STREET ASSOCIATES P. O. BOX 100 YORK HARBOR, ME 03911
- 125 2 N/F SHAINES AND McEACHERN CO (PORTSMOUTH) LLC 282 CORPORATE DRIVE PORTSMOUTH, N.H. 03801 4496 / 0556
- 125 55 N/F STEPHEN & CHRISTINE MAYEUX 64 BRIDGE STREET PORTSMOUTH, N.H. 03801 2869 / 0647
- 125 59 N/F CITY OF PORTSMOUTH P. O. BOX 628 PORTSMOUTH, N.H. 03802 2166 / 0388 #D-4125

- PLAN REFERENCES:**
1. VAUGHAN STREET URBAN RENEWAL PROJECT N.H. R-10, PORTSMOUTH, NEW HAMPSHIRE, DISPOSITION PLAN PARCEL 7. DATED OCT. 1973 BY ANDERSON-NIHOLS & CO., INC. RCRD #D-4119.
  2. VAUGHAN STREET URBAN RENEWAL PROJECT N.H. R-10, PORTSMOUTH, NEW HAMPSHIRE, DISPOSITION PLAN PARCEL 10. DATED OCT. 1973 BY ANDERSON-NIHOLS & CO., INC. RCRD #D-4125.
  3. VAUGHAN STREET URBAN RENEWAL PROJECT N.H. R-10, PORTSMOUTH, NEW HAMPSHIRE, DISPOSITION MAP, DATED NOV. 1969 BY ANDERSON-NIHOLS & CO., INC. RCRD #D-2408.
  4. EASEMENT SITE PLAN, TAX MAP 125 - LOT 2, 30 MAPLEWOOD, LLC TO PUBLIC SERVICE COMPANY OF NEW HAMPSHIRE (PSNH), SCALE: 1" = 20', OCTOBER 2013 BY AMBIT ENGINEERING. RCRD D-38148.
  5. PROPOSED EASEMENT TO CITY OF PORTSMOUTH, SCALE: 1" = 10', 9/18/13 BY AMBIT ENGINEERING. BK 5512, PG 1046.
  6. CONDOMINIUM SITE PLAN, TAX MAP 125 - LOT 2, BY AMBIT ENGINEERING. RCRD D-38936; AMENDED AT RCRD D-39005.
  7. SUBDIVISION PLAN, TAX MAP 125 - LOT 2, OWNER: 30 MAPLEWOOD, LLC, 30-46 MAPLEWOOD AVENUE, CITY OF PORTSMOUTH, STATE OF NEW HAMPSHIRE, DATED OCTOBER 2015. RCRD PLAN D-40246.
  8. SITE PLAN, TAX MAP 125 LOT 2, 30 MAPLEWOOD AVENUE, CITY OF PORTSMOUTH, COUNTY OF ROCKINGHAM, STATE OF NEW HAMPSHIRE, DATED AUGUST 2015. RCRD PLAN D-39173.

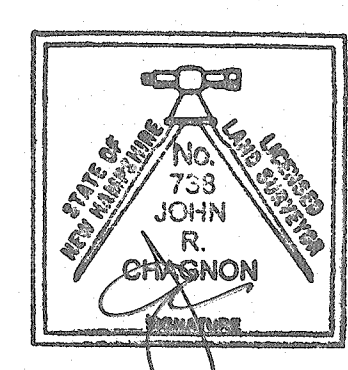
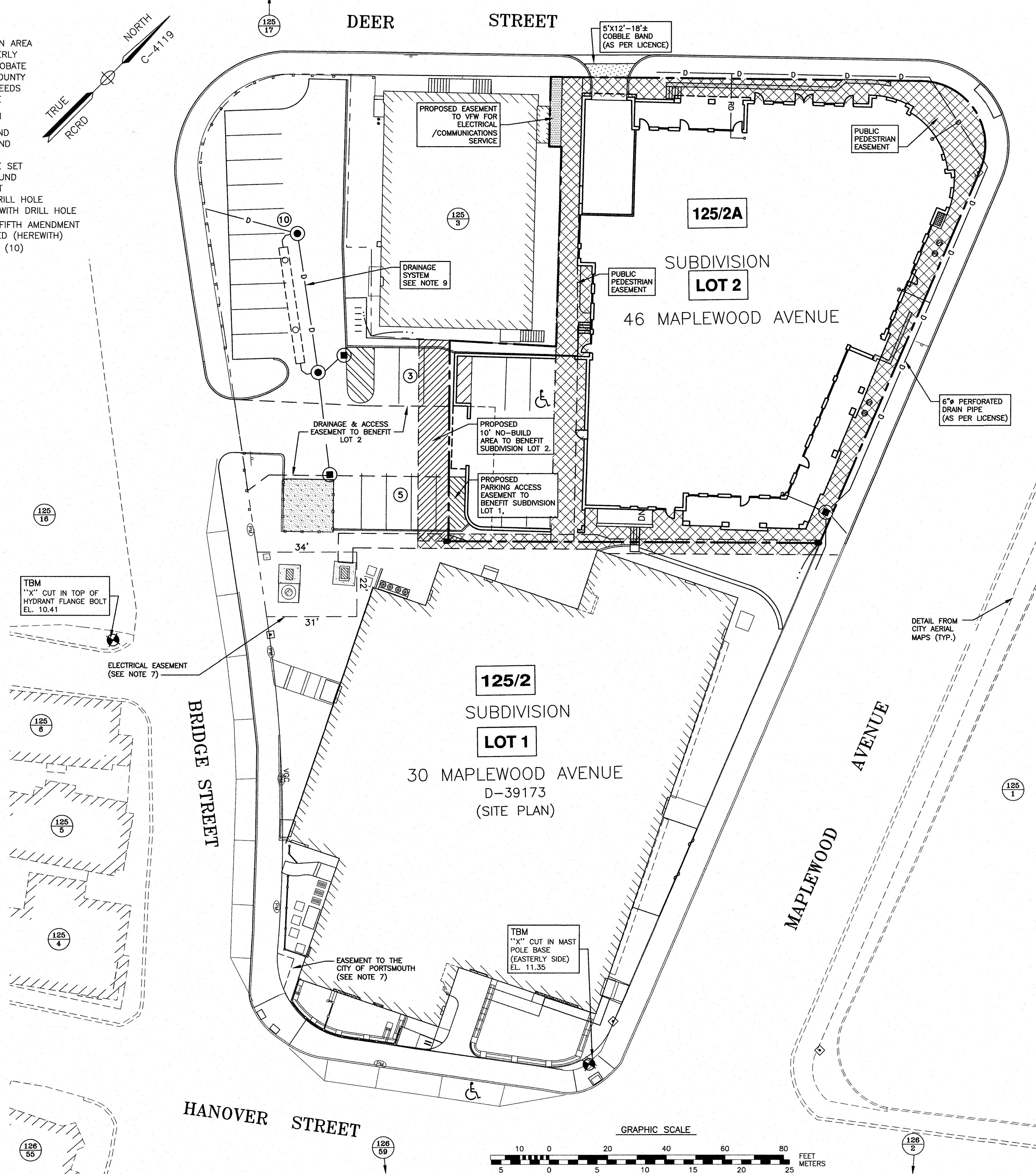

APPROVED BY THE PORTSMOUTH PLANNING BOARD

CHAIRMAN \_\_\_\_\_ DATE \_\_\_\_\_

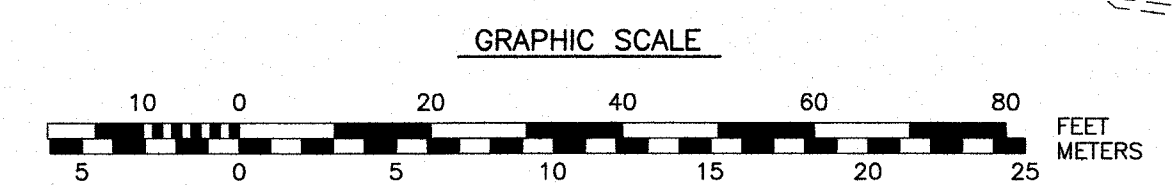

J:\0951\UN1800s\UN1800s\UN1800s\2017 Site Plan 46 Maplewood\Plans & Specs\Site\1809W046.dwg, EASEMENT

LINE	BEARING	DISTANCE
L1	S46°31'15"W	4.30'

CURVE	RADIUS	ARC LENGTH	CHORD LENGTH	CHORD BEARING	DELTA ANGLE
C1	22.00'	43.23'	36.60'	S78°04'35"E	112°35'04"

- PLAN REFERENCES:**
- 1) VAUGHAN STREET URBAN RENEWAL PROJECT N.H. R-10, PORTSMOUTH, NEW HAMPSHIRE, DISPOSITION PLAN PARCEL 7, DATED OCT. 1973 BY ANDERSON-NIHOLS & CO., INC. RCRD #D-4119.
  - 2) VAUGHAN STREET URBAN RENEWAL PROJECT N.H. R-10, PORTSMOUTH, NEW HAMPSHIRE, DISPOSITION PLAN PARCEL 10, DATED OCT. 1973 BY ANDERSON-NIHOLS & CO., INC. RCRD #D-4125.
  - 3) VAUGHAN STREET URBAN RENEWAL PROJECT N.H. R-10, PORTSMOUTH, NEW HAMPSHIRE, DISPOSITION PLAN, DATED NOV. 1969 BY ANDERSON-NIHOLS & CO., INC. RCRD #D-2408.
  - 4) SUBDIVISION PLAN, 30 MAPLEWOOD LLC, 1"=20', OCTOBER 2015 RCRD #D-40246

- LEGEND:**
- N/F NOW OR FORMERLY
  - RP RECORD OF PROBATE
  - RCRD ROCKINGHAM COUNTY REGISTRY OF DEEDS
  - RR SPK RAILROAD SPIKE
  - MAP 11/LOT 21
  - IR FND IRON ROD FOUND
  - IP FND IRON PIPE FOUND
  - IR SET IRON ROD SET
  - CONCRETE BOUND FOUND

**DRAIN STRUCTURE TABLE**

STRUCTURE	RIM ELEV.	INV. ELEV. IN	PIPE SIZE & TYPE
CB 3522	10.09	7.48±	12" RCP (NE)
		6.29	12" (NW)
CB 3523	9.49	6.29	12" (NW)
		6.29	12" (NW)
DMH 3540	10.78	NA	18" RCP (NE)
		1.53	48" RCP (NW)
DMH 3541	10.23	7.48±	12" RCP (SW)
		2.07	36" (S)
DMH 3542	9.41	1.93	36"
		2.58	36"
		2.18	36"

**SEWER STRUCTURE TABLE**

STRUCTURE	RIM ELEV.	INV. ELEV. IN	PIPE SIZE & TYPE
1491	10.10	0.60	21" VC (SE)
		0.50	14" VC (S)
		0.51	21" VC (NE)
1492	11.17	3.52	6" PVC
		?	21" VC
1493	10.04	2.49	6" VC (NE)
		2.39	6" VC (NW)
1499	15.77	-1.89	48" BOX SEWER
		-1.89	48" BOX SEWER
1500	14.14	-	-
2305	10.87	7.31	6" VC (SW)
		-1.20	48" VC
5317	8.24	1.29	14" AC (ESE)
		1.18	14" AC (NW)
5318	9.85	0.60	21" VC (SE)
		0.40	21" VC (NW)

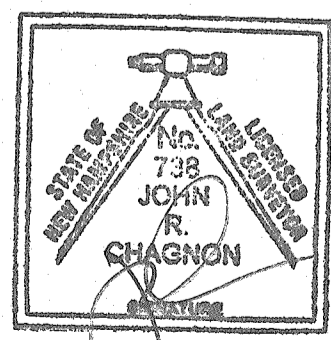

APPROVED BY THE PORTSMOUTH PLANNING BOARD

CHAIRMAN \_\_\_\_\_ DATE \_\_\_\_\_

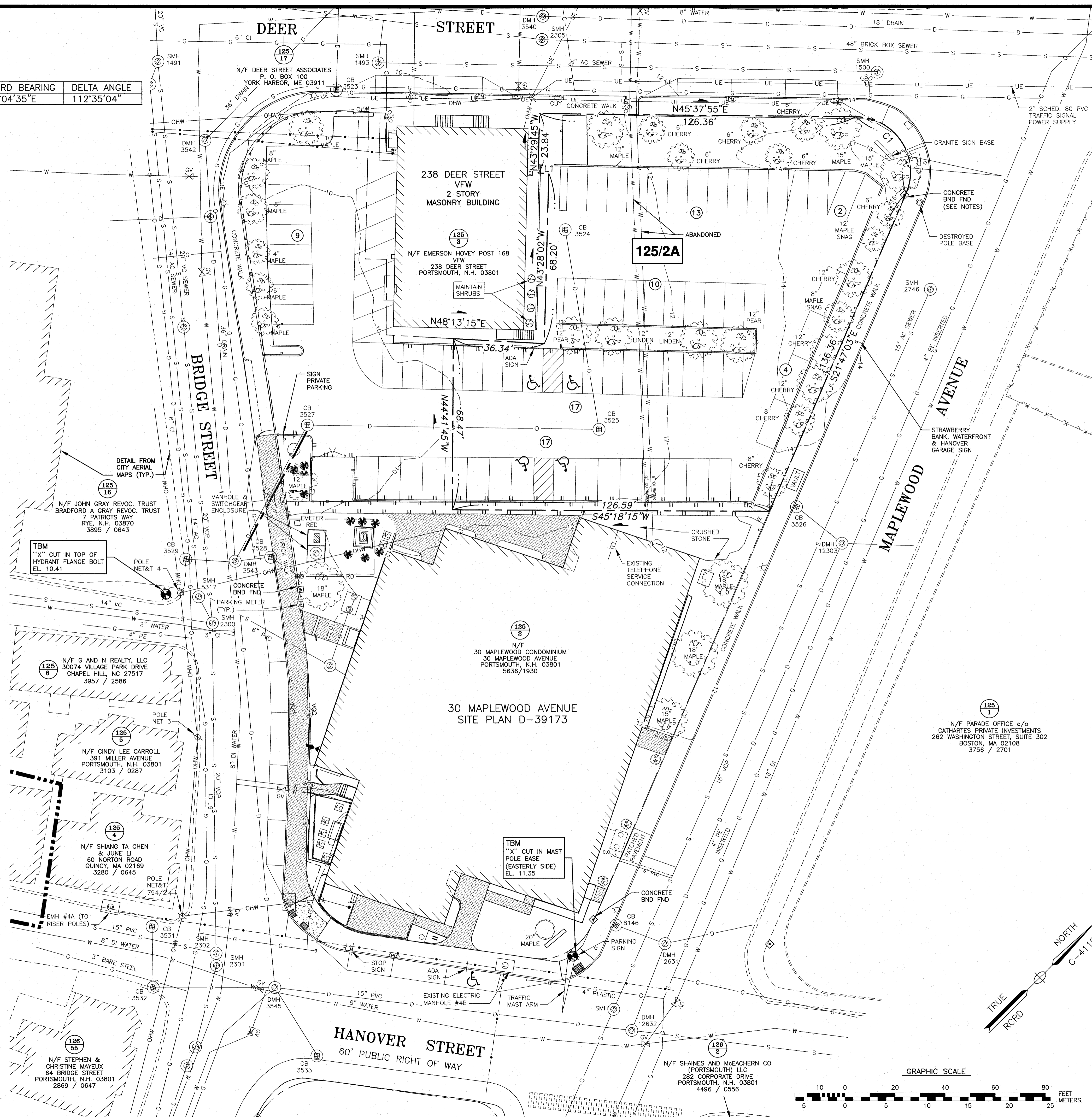

**AMBIT ENGINEERING, INC.**  
Civil Engineers & Land Surveyors  
200 Griffin Road, Unit 3  
Portsmouth, N.H. 03801-7114  
Tel (603) 430-9282  
Fax (603) 436-2315

- NOTES:**
1. PARCEL IS SHOWN ON THE CITY OF PORTSMOUTH ASSESSOR'S MAP 125 AS LOT 2A.
  2. OWNER OF RECORD:  
30 MAPLEWOOD, LLC  
30 MAPLEWOOD AVENUE  
PORTSMOUTH, N.H. 03801  
5099 / 2424  
PLAN C-4119
  3. PARCEL IS NOT IN A FLOOD HAZARD ZONE AS SHOWN ON FIRM PANEL 33015C0259E, MAY 17, 2005.
- EXISTING LOT AREA:  
21,798 S.F.  
0.5004 ACRES
4. PARCEL IS LOCATED IN CHARACTER DISTRICT 4-L (CD-4L), HISTORIC DISTRICT A, AND DOWNTOWN OVERLAY DISTRICT.
  5. DIMENSIONAL REQUIREMENTS: (VESTED TO OLD ZONING - CBB)  
MIN. LOT AREA: 2,000 S.F.  
FRONTAGE: NOT APPLICABLE  
SETBACKS: FRONT 0 FEET  
SIDE 0 FEET  
REAR 0 FEET  
MAXIMUM STRUCTURE HEIGHT: 60 FEET  
MAXIMUM BUILDING COVERAGE: 95%  
MINIMUM OPEN SPACE: 0%
  6. THE PURPOSE OF THIS PLAN IS TO SHOW THE EXISTING CONDITIONS AT THE SITE.
  7. WORK ON PHASE I IS ONGOING. PLAN MAY SHOW SOME APPROVED, BUT NOT YET CONSTRUCTED ELEMENTS.
  8. DATUM: NGVD 1988 (NAD)  
MEAN SEA LEVEL  
BENCHMARK: "X" CUT IN EASTERLY SIDE OF SIGNAL MAST BASE AT NORTHWEST CORNER OF MAPLEWOOD AVENUE AND HANOVER STREET. ELEV. 11.56
  9. SEE PLAN REFERENCE 2 FOR INFORMATION REGARDING RELATION OF CONCRETE BOUNDS TO PROPERTY CORNERS. CONTRACTOR RESPONSIBLE TO MAINTAIN PROPERTY CORNER AND/OR HIRE A LICENSED LAND SURVEYOR TO REPLACE PROPERTY MARKERS ON NEW SURFACES AT THE COMPLETION OF CONSTRUCTION.

**TAX MAP 125 LOT 2A**  
**46-64 MAPLEWOOD AVENUE**  
**PORTSMOUTH, N.H.**

NO.	DESCRIPTION	DATE
2	NOTE 9	1/12/18
1	REVISED UTILITIES AND PAVEMENT TYPES	10/17/17
0	ISSUED FOR COMMENT	6/19/17

SCALE: 1" = 20'  
JUNE 2017

EXISTING CONDITIONS PLAN  
**C1**

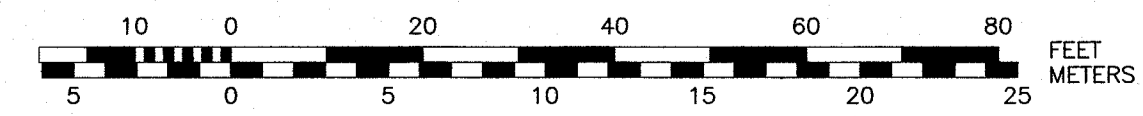

J:\0851\UN18005\UN18005\2017 Site Plan 46 Maplewood\Plans & Specs\Site\1808046.dwg, C1\_EXIST\_COND

**DEMOLITION NOTES**

- a) THE LOCATIONS OF UNDERGROUND UTILITIES ARE APPROXIMATE AND THE LOCATIONS ARE NOT GUARANTEED BY THE OWNER OR THE DESIGNER. IT IS THE CONTRACTORS' RESPONSIBILITY TO LOCATE UTILITIES AND ANTICIPATE CONFLICTS. CONTRACTOR SHALL REPAIR EXISTING UTILITIES DAMAGED BY THEIR WORK AND RELOCATE EXISTING UTILITIES THAT ARE REQUIRED TO BE RELOCATED PRIOR TO COMMENCING ANY WORK IN THE IMPACTED AREA OF THE PROJECT.
- b) ALL MATERIALS SCHEDULED TO BE REMOVED SHALL BECOME THE PROPERTY OF THE CONTRACTORS UNLESS OTHERWISE SPECIFIED. THE CONTRACTOR SHALL DISPOSE OF ALL MATERIALS OFF-SITE IN ACCORDANCE WITH ALL FEDERAL, STATE, AND LOCAL REGULATIONS, ORDINANCES AND CODES. THE CONTRACTOR SHALL COORDINATE REMOVAL, RELOCATION, DISPOSAL, OR SALVAGE OF UTILITIES WITH THE OWNER AND APPROPRIATE UTILITY COMPANY.
- c) ANY EXISTING WORK OR PROPERTY DAMAGED OR DISRUPTED BY CONSTRUCTION/DEMOLITION ACTIVITIES SHALL BE REPLACED OR REPAIRED TO THE ORIGINAL EXISTING CONDITIONS BY THE CONTRACTOR AT NO ADDITIONAL COST TO THE OWNER.
- d) THE CONTRACTOR SHALL VERIFY LOCATION OF ALL EXISTING UTILITIES AND CALL DIG SAFE AT LEAST 72 HOURS PRIOR TO THE COMMENCEMENT OF ANY DEMOLITION/CONSTRUCTION ACTIVITIES.
- e) SAWCUT AND REMOVE PAVEMENT ONE FOOT OFF PROPOSED EDGE OF PAVEMENT OR EXISTING CURB LINE IN AREAS WHERE PAVEMENT TO BE REMOVED ABUTS EXISTING PAVEMENT OR CONCRETE TO REMAIN.
- f) IT IS THE CONTRACTOR'S RESPONSIBILITY TO FAMILIARIZE THEMSELVES WITH THE CONDITIONS OF ALL THE PERMIT APPROVALS.
- g) THE CONTRACTOR SHALL OBTAIN AND PAY FOR ADDITIONAL CONSTRUCTION PERMITS, NOTICES AND FEES NECESSARY TO COMPLETE THE WORK AND ARRANGE FOR AND PAY FOR ANY INSPECTIONS AND APPROVALS FROM THE AUTHORITIES HAVING JURISDICTION. THE CONTRACTOR SHALL BE RESPONSIBLE FOR ANY ADDITIONAL AND OFF-SITE DISPOSAL OF MATERIALS REQUIRED TO COMPLETE THE WORK.
- h) THE CONTRACTOR SHALL REMOVE AND DISPOSE OF ALL EXISTING STRUCTURES, CONCRETE, UTILITIES, VEGETATION, PAVEMENT, AND CONTAMINATED SOIL WITHIN THE WORK LIMITS SHOWN UNLESS SPECIFICALLY IDENTIFIED TO REMAIN. ANY EXISTING DOMESTIC / IRRIGATION SERVICE WELLS IN THE PROJECT AREA IDENTIFIED DURING THE CONSTRUCTION AND NOT CALLED OUT ON THE PLANS SHALL BE BROUGHT TO THE ATTENTION OF THE OWNER AND ENGINEER FOR PROPER CAPPING / RE-USE. ANY EXISTING MONITORING WELLS IN THE PROJECT AREA IDENTIFIED DURING THE CONSTRUCTION AND NOT CALLED OUT ON THE PLANS SHALL BE BROUGHT TO THE ATTENTION OF THE OWNER AND ENGINEER TO COORDINATE MONITORING WELL REMOVAL AND/OR RELOCATION WITH NHDES AND OTHER AUTHORITY WITH JURISDICTION PRIOR TO CONSTRUCTION.
- i) ALL WORK WITHIN THE CITY OF PORTSMOUTH RIGHT OF WAY SHALL BE COORDINATED WITH THE CITY OF PORTSMOUTH DEPARTMENT OF PUBLIC WORKS (DPW).
- j) REMOVE TREES AND BRUSH AS REQUIRED FOR COMPLETION OF WORK. CONTRACTOR SHALL GRUB AND REMOVE ALL SLUMPS WITHIN LIMITS OF WORK AND DISPOSE OF OFF-SITE IN ACCORDANCE WITH FEDERAL, STATE, AND LOCAL LAWS AND REGULATIONS.
- k) CONTRACTOR SHALL PROTECT ALL PROPERTY MONUMENTATION THROUGHOUT DEMOLITION AND CONSTRUCTION OPERATIONS. SHOULD ANY MONUMENTATION BE DISTURBED, THE CONTRACTOR SHALL EMPLOY A NH LICENSED LAND SURVEYOR TO REPLACE THEM.
- l) PROVIDE INLET PROTECTION BARRIERS AT ALL CATCH BASINS WITHIN CONSTRUCTION LIMITS AND MAINTAIN FOR THE DURATION OF THE PROJECT. INLET PROTECTION BARRIERS SHALL BE HIGH FLOW SILT SACK BY ACF ENVIRONMENTAL OR APPROVED EQUAL. INSPECT BARRIERS WEEKLY AND AFTER EACH RAIN OF 0.25 INCHES OR GREATER. CONTRACTOR SHALL COMPLETE A MAINTENANCE INSPECTION REPORT AFTER EACH INSPECTION. SEDIMENT DEPOSITS SHALL BE REMOVED AFTER EACH STORM EVENT OR MORE OFTEN IF WARRANTED OR FABRIC BECOMES CLOGGED. EROSION CONTROL MEASURES SHALL BE INSTALLED PRIOR TO THE START OF ANY CLEARING OR DEMOLITION ACTIVITIES.
- m) THE CONTRACTOR SHALL PAY ALL COSTS NECESSARY FOR TEMPORARY PARTITIONING, BARRICADING, FENCING, SECURITY AND SAFETY DEVICES REQUIRED FOR THE MAINTENANCE OF A CLEAN AND SAFE CONSTRUCTION SITE.
- n) ANY CONTAMINATED MATERIAL REMOVED DURING THE COURSE OF THE WORK WILL REQUIRE HANDLING IN ACCORDANCE WITH NHDES REGULATIONS. CONTRACTOR SHALL HAVE A HEALTH AND SAFETY PLAN IN PLACE, AND COMPLY WITH ALL APPLICABLE PERMITS, APPROVALS, AUTHORIZATIONS, AND REGULATIONS

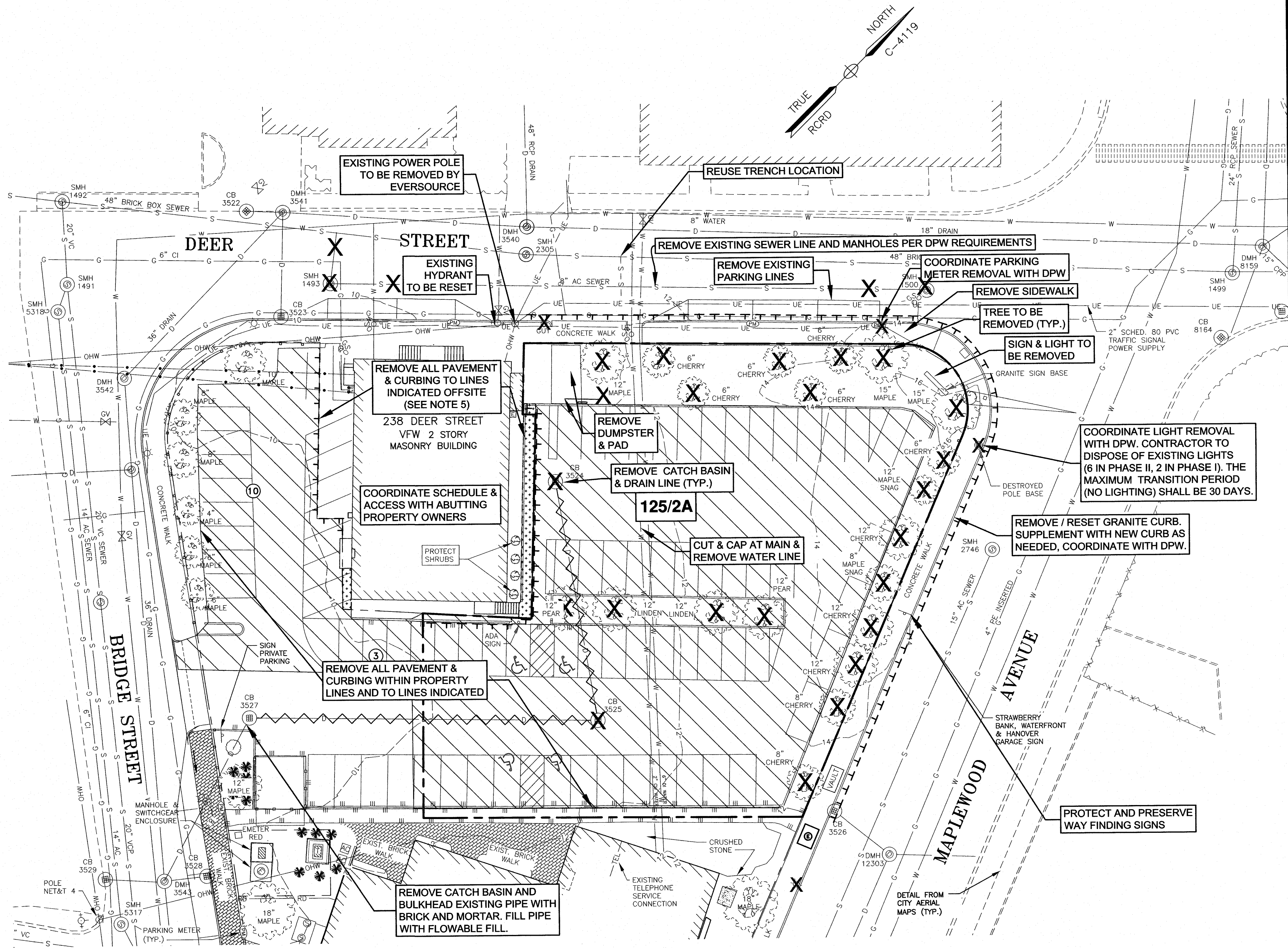

**AMBIT ENGINEERING, INC.**  
Civil Engineers & Land Surveyors  
200 Griffin Road, Unit 3  
Portsmouth, N.H. 03801-7114  
Tel (603) 430-9282  
Fax (603) 436-2315

- NOTES:**
- 1) THE CONTRACTOR SHALL NOTIFY DIG SAFE AT 1-888-DIG-SAFE (1-888-344-7233) AT LEAST 72 HOURS PRIOR TO COMMENCING ANY EXCAVATION ON PUBLIC OR PRIVATE PROPERTY.
  - 2) UNDERGROUND UTILITY LOCATIONS ARE BASED UPON BEST AVAILABLE EVIDENCE AND ARE NOT FIELD VERIFIED. LOCATING AND PROTECTING ANY ABOVEGROUND OR UNDERGROUND UTILITIES IS THE SOLE RESPONSIBILITY OF THE CONTRACTOR AND/OR THE OWNER. UTILITY CONFLICTS SHOULD BE REPORTED AT ONCE TO THE DESIGN ENGINEER.
  - 3) CONTRACTOR SHALL INSTALL AND MAINTAIN EROSION CONTROL MEASURES IN ACCORDANCE WITH THE "NEW HAMPSHIRE STORMWATER MANUAL, VOLUME 3, EROSION AND SEDIMENT CONTROLS DURING CONSTRUCTION. (NHDES DECEMBER 2008).
  - 4) MAINTAIN ACCESS TO VFW EXIT DOORS DURING CONSTRUCTION.
  - 5) OFFSITE PAVEMENT REMOVAL REQUIRES APPROVAL OF ADJACENT PROPERTY OWNER. IF APPROVAL IS NOT OBTAINED THEN LEAVE IN PLACE. COORDINATE WITH OWNER.
  - 6) CHANGES IN THE LOCATION OF STREET LIGHT POLES SHALL BE COORDINATED WITH THE CITY'S WAYFINDING PROGRAM SO THAT THE WAYFINDING SIGNS ARE MAINTAINED.

**TAX MAP 125 LOT 2A  
46-64 MAPLEWOOD AVENUE  
PORTSMOUTH, N.H.**

3	SEWER STUB	1/12/18
2	SEWER LINE REMOVAL, DEMOLITION NOTES	12/19/17
1	ISSUED FOR APPROVAL	10/17/17
0	ISSUED FOR COMMENT	6/19/17
NO.	DESCRIPTION	DATE
REVISIONS		

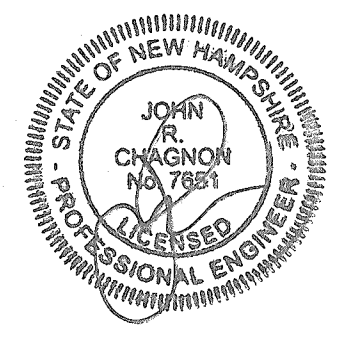

SCALE: 1" = 20' JUNE 2017

**DEMOLITION PLAN C2**

APPROVED BY THE PORTSMOUTH PLANNING BOARD  
CHAIRMAN \_\_\_\_\_ DATE \_\_\_\_\_

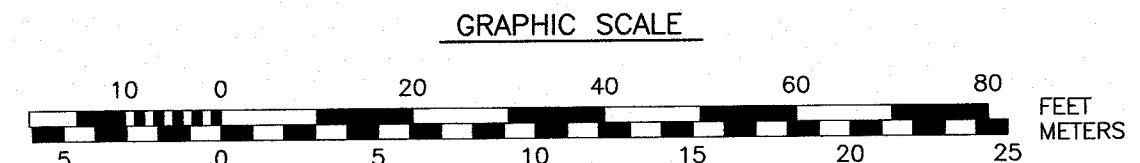

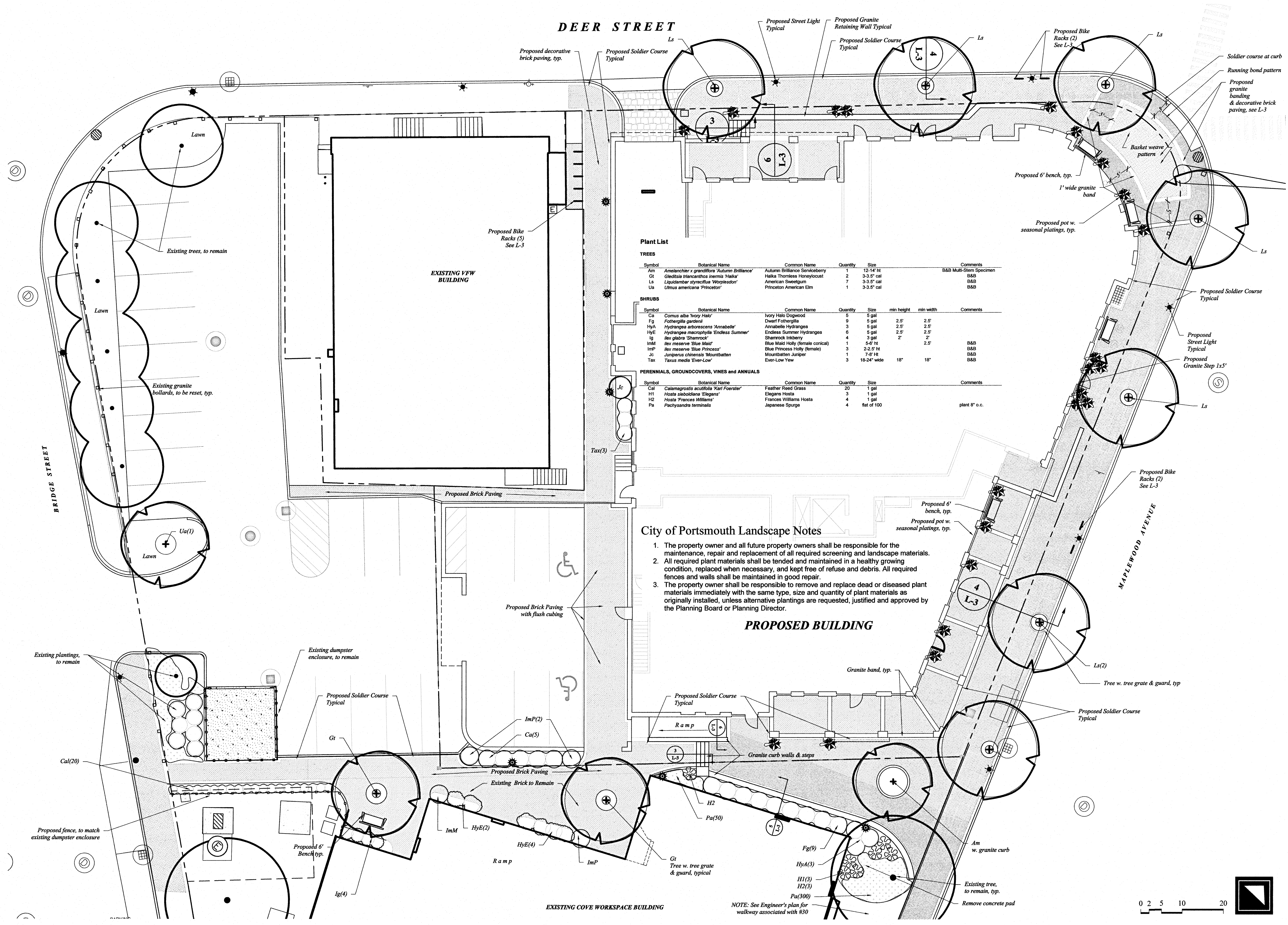

**Plant List**

**TREES**

Symbol	Botanical Name	Common Name	Quantity	Size	Comments
Am	<i>Amelanchier v. grandiflora</i> 'Autumn Brilliance'	Autumn Brilliance Serviceberry	1	12-14' Ht	B&B Multi-Stem Specimen
Gt	<i>Gleditsia triacanthos inermis</i> 'Halka'	Halka Thornless Honeylocust	2	3-3.5' cal	B&B
Ls	<i>Liquidambar styraciflua</i> 'Worplesdon'	American Sweetgum	7	3-3.5' cal	B&B
Ua	<i>Ulmus americana</i> 'Princeton'	Princeton American Elm	1	3-3.5' cal	B&B

**SHRUBS**

Symbol	Botanical Name	Common Name	Quantity	Size	min height	min width	Comments
Ca	<i>Cornus alba</i> 'Ivory Halo'	Ivory Halo Dogwood	5	5 gal			
Fg	<i>Fothergilla gardenii</i>	Dwarf Fothergilla	9	5 gal	2.5'	2.5'	
HyA	<i>Hydrangea arborescens</i> 'Annabelle'	Annabelle Hydrangea	3	5 gal	2.5'	2.5'	
HyE	<i>Hydrangea macrophylla</i> 'Endless Summer'	Endless Summer Hydrangea	6	5 gal	2.5'	2.5'	
Ig	<i>Ilex glabra</i> 'Shamrock'	Shamrock Inkberry	4	3 gal	2'	2'	
ImM	<i>Ilex meservee</i> 'Blue Maid'	Blue Maid Holly (female conical)	1	5-6' Ht		2.5'	B&B
Imp	<i>Ilex meservee</i> 'Blue Princess'	Blue Princess Holly (female)	3	2-2.5' Ht			B&B
Jc	<i>Juniperus chinensis</i> 'Mountbatten'	Mountbatten Juniper	1	7-8' Ht			B&B
Tax	<i>Taxus media</i> 'Ever-Low'	Ever-Low Yew	3	18-24" wide	18"	18"	B&B

**PERENNIALS, GROUNDCOVERS, VINES AND ANNUALS**

Symbol	Botanical Name	Common Name	Quantity	Size	Comments
Cal	<i>Calamagrostis acutiflora</i> 'Karl Foerster'	Feather Reed Grass	20	1 gal	
H1	<i>Hosta sieboldiana</i> 'Elegans'	Elegans Hosta	3	1 gal	
H2	<i>Hosta 'Frances Williams'</i>	Frances Williams Hosta	4	1 gal	
Pa	<i>Pachysandra terminalis</i>	Japanese Spurge	4	flat of 100	plant 8" o.c.

**City of Portsmouth Landscape Notes**

- The property owner and all future property owners shall be responsible for the maintenance, repair and replacement of all required screening and landscape materials.
- All required plant materials shall be tended and maintained in a healthy growing condition, replaced when necessary, and kept free of refuse and debris. All required fences and walls shall be maintained in good repair.
- The property owner shall be responsible to remove and replace dead or diseased plant materials immediately with the same type, size and quantity of plant materials as originally installed, unless alternative plantings are requested, justified and approved by the Planning Board or Planning Director.

**PROPOSED BUILDING**

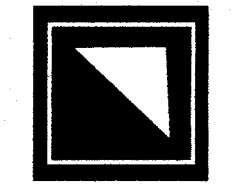
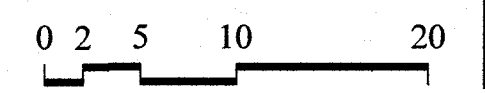

NOTE: See Engineer's plan for walkway associated with #30



*Existing Board Fence to be repeated*



*Portsmouth Street Light*

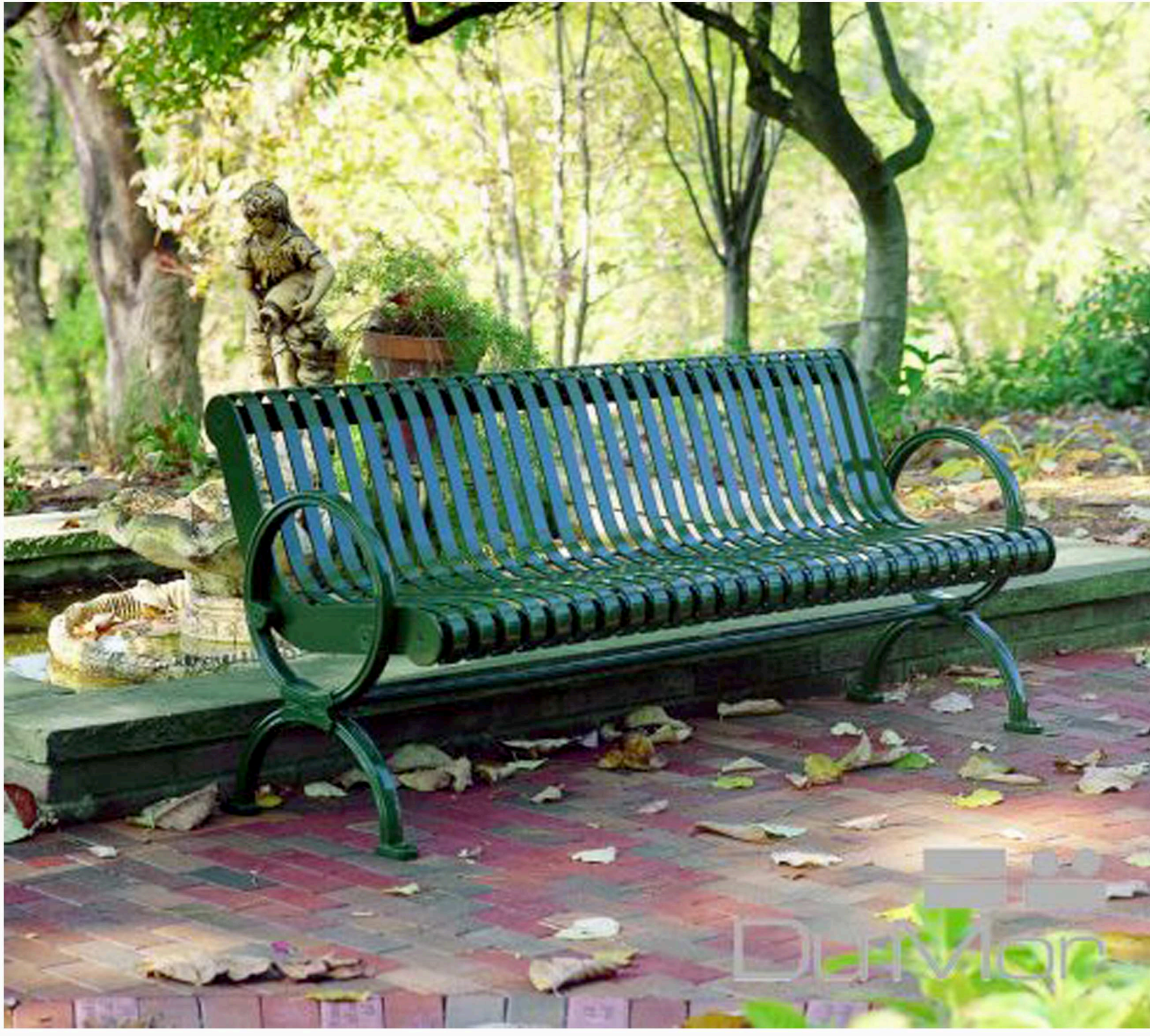

*Bench (9) - DuMor 119, black*



*Trash Receptacle - DuMor 157  
32 gal. with shield*



*Ironsmith Olympian 60" Tree Grate*



*Ironmith M-13 Tree Guard*



*Campania Sandhurst - 26"*



*Campania Vallarella*

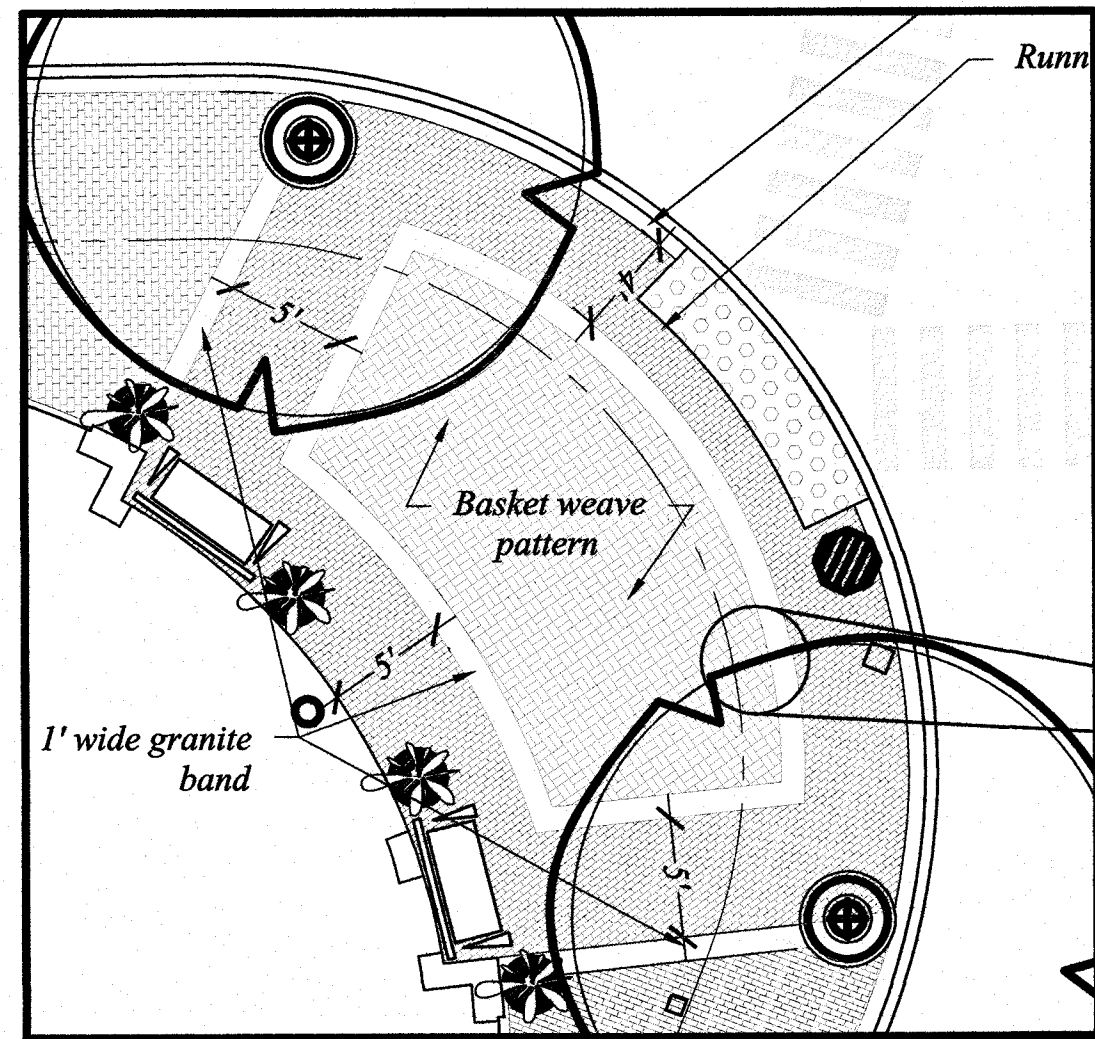

**1 ENTRY PAVING ENLARGEMENT**  
Scale: 1/8"=1'-0"

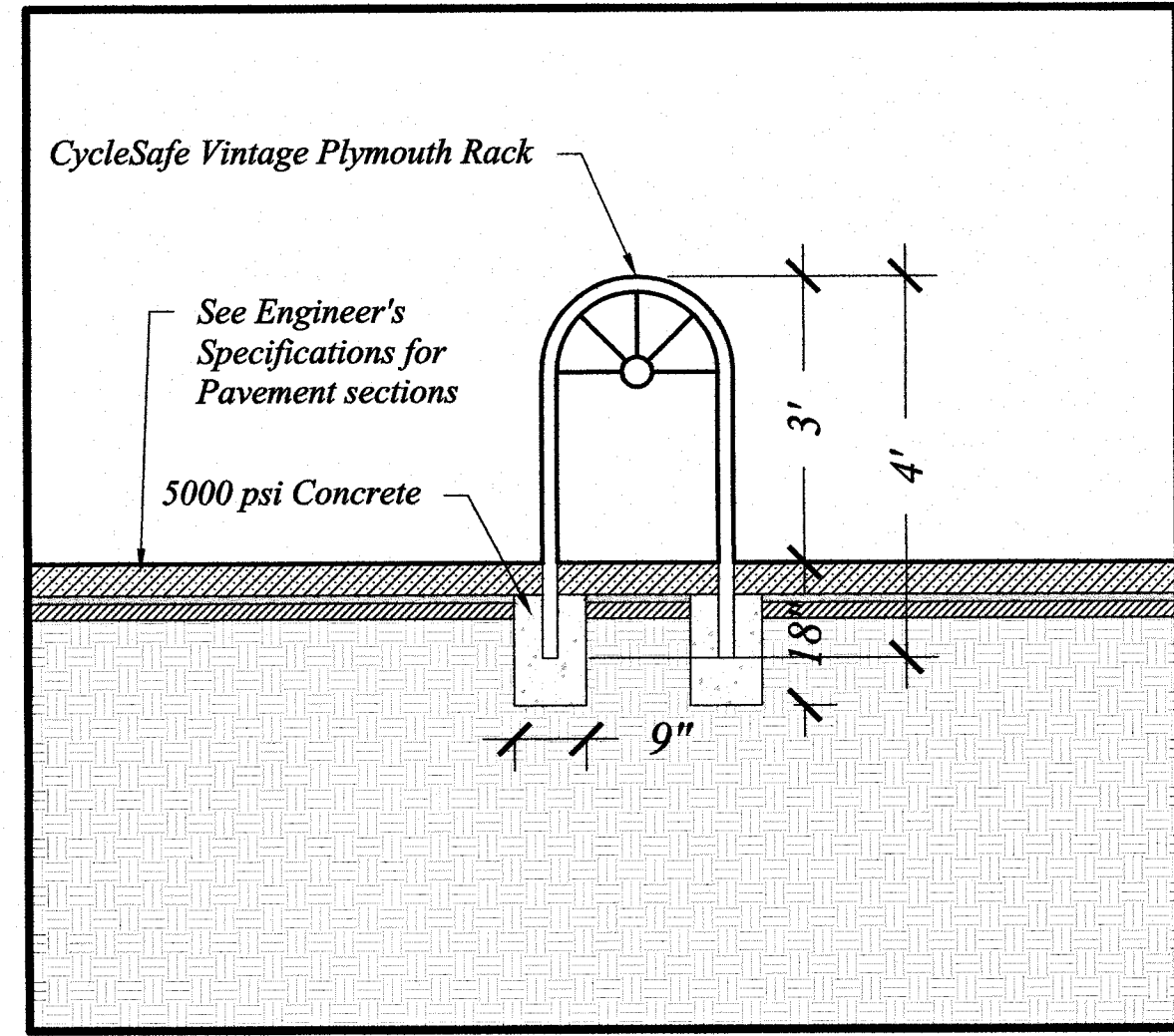

**2 BIKE RACK**  
Scale: 1/2"=1'-0"

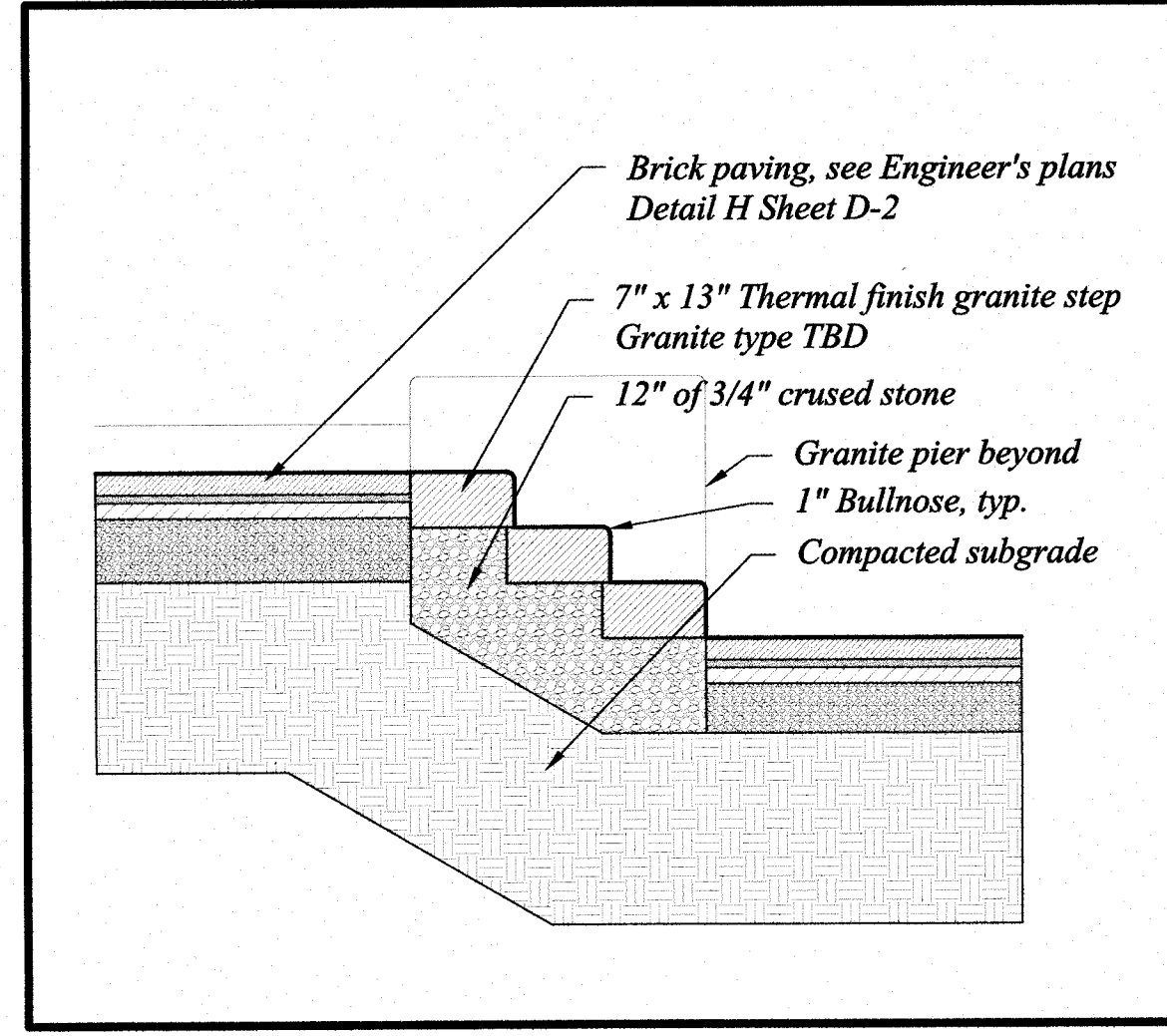

**3 GRANITE STEPS**  
Scale: 1/2"=1'-0"

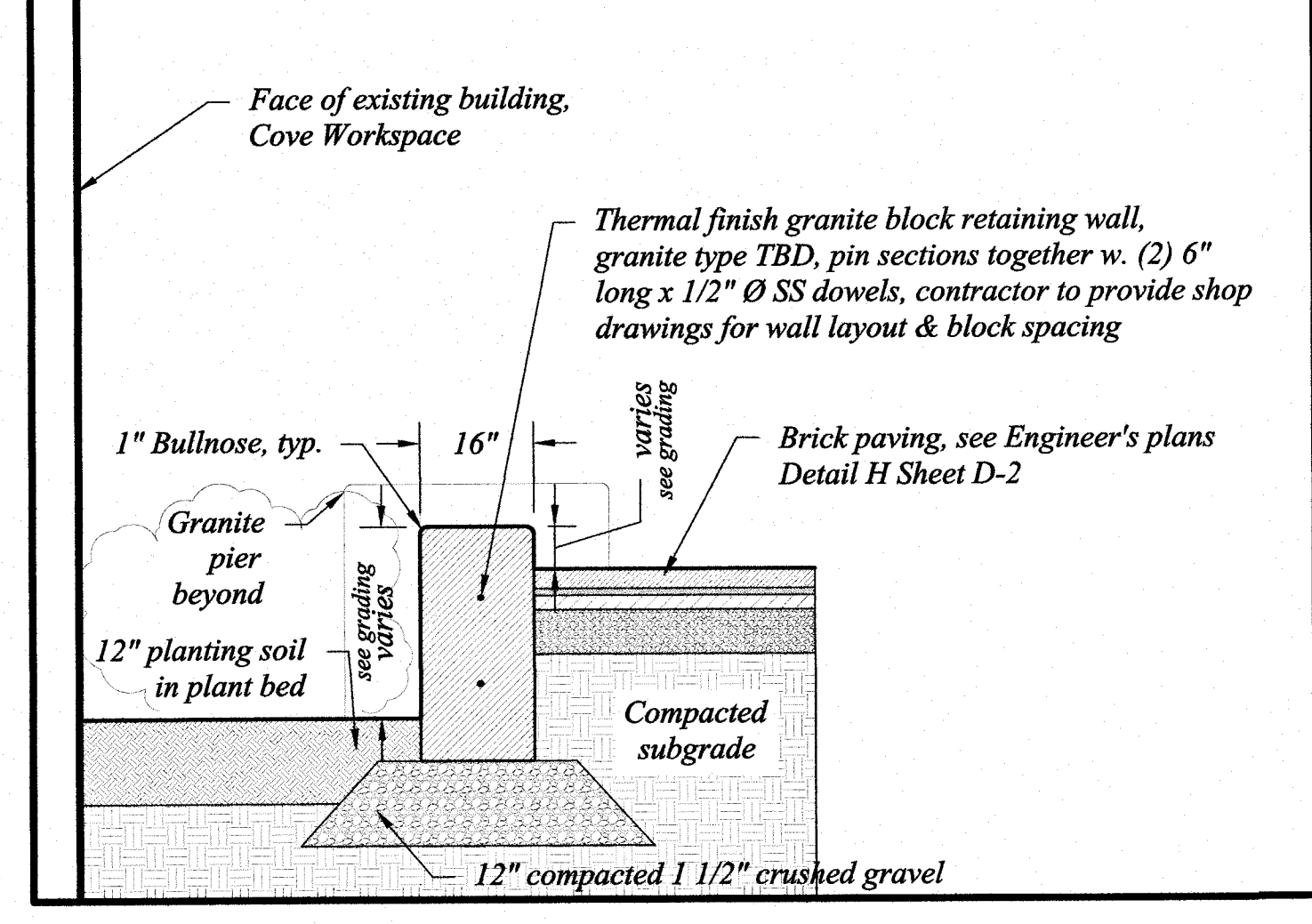

**5 RETAINING WALL AT COVE**  
Scale: 1/2"=1'-0"

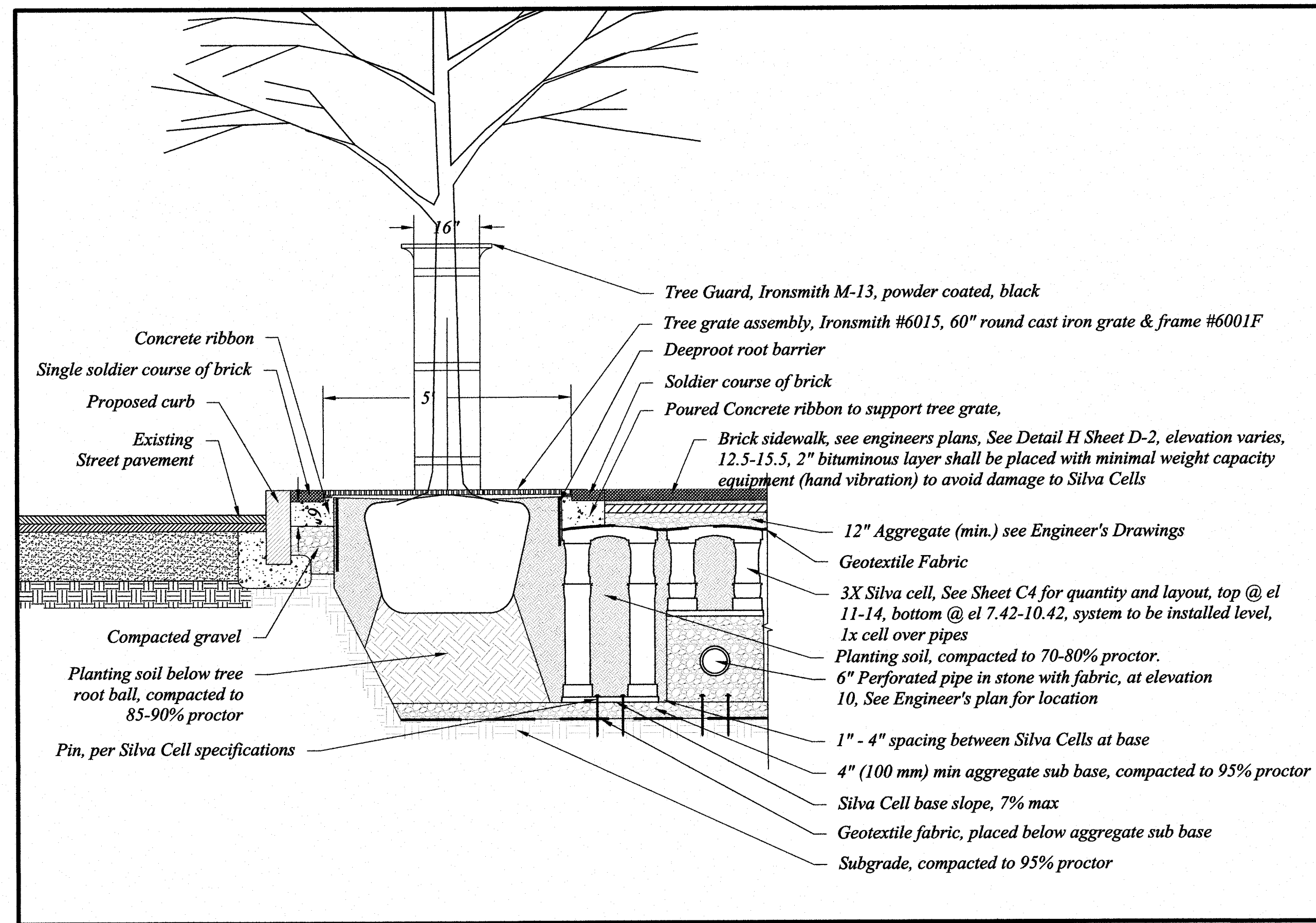

**4 PROPOSED TREE WITH TREE GRATE & GUARD & SILVA CELLS BELOW**  
Scale: 1/2"=1'-0"

**NOTES ON SILVA CELLS:**

1. Silva Cell installation shall be coordinated with Deeproot Green Infrastructure, LLC (Al Key 212-353-8788) Woodburn & Company (Robbi Woodburn 603-659-5949) and Ambit Engineering (John Chagnon 603-430-9282). On site pre-construction meeting to be arranged by contractor prior to commencing construction on system.
2. Silva Cells shall be installed prior to curb placement.

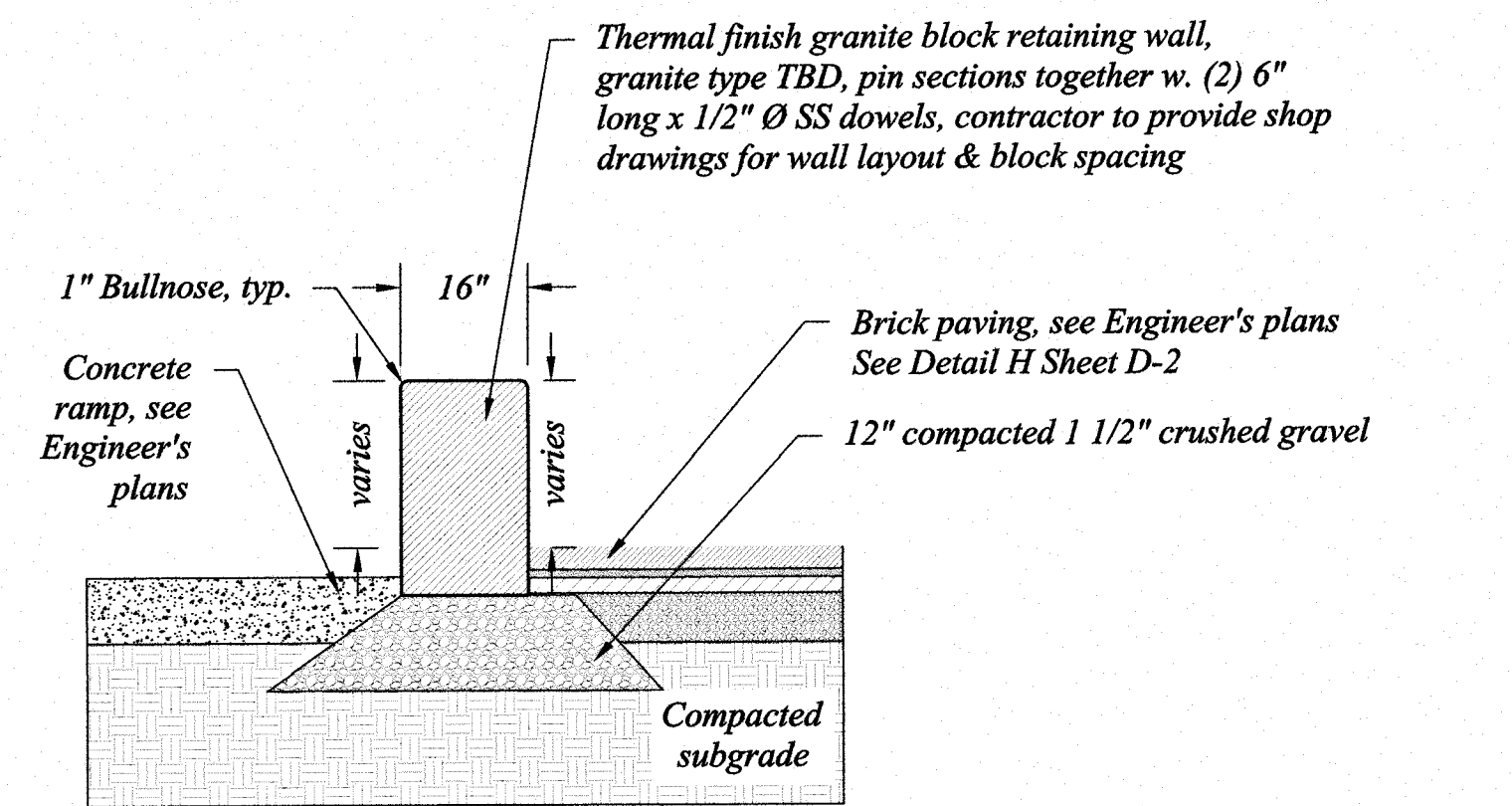

**6 RETAINING WALL AT RAMP**  
Scale: 1/2"=1'-0"

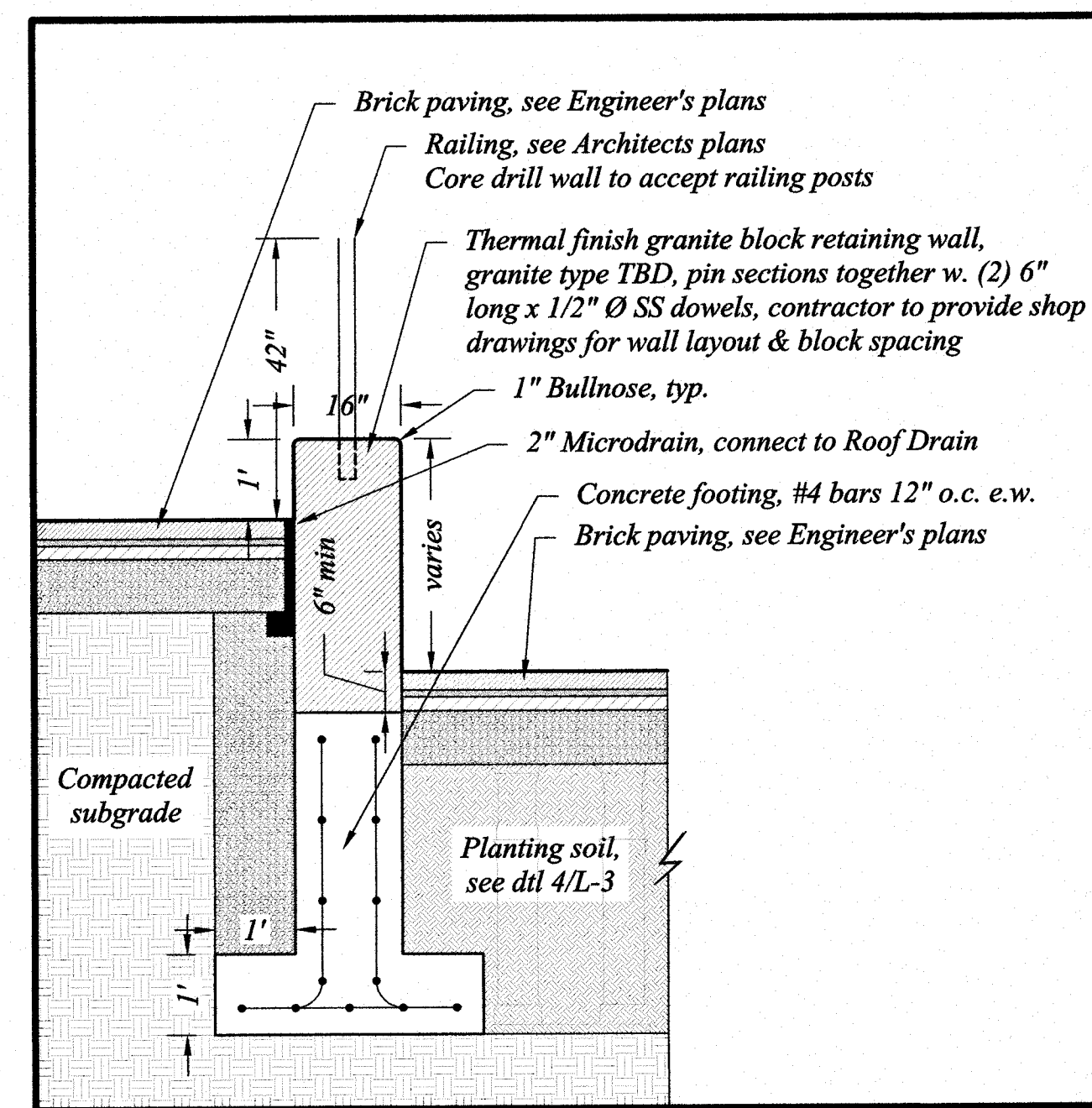

**7 RETAINING WALL AT DEER STREET**  
Scale: 1/2"=1'-0"

- NOTES:**
- PROPOSED BUILDING USES:  
 BASEMENT: PARKING, MERCHANDISE, STORAGE, UTILITIES, CIRCULATION  
 1st FLOOR: PARKING, RETAIL, OFFICE, RESTAURANT  
 2nd to PENTHOUSE FLOOR: RESIDENTIAL & OFFICE  
 22 RESIDENTIAL UNITS AND 1 OFFICE SPACE  
 PARKING CALCULATIONS  
 REQUIRED PARKING:  
 22 RESIDENTIAL UNITS x 1.5 SPACE/UNIT = 33 SPACES  
 33 - 4 (ORDINANCE REDUCTION) = 29 SPACES REQUIRED  
 SPACES PROVIDED: 36 SPACES (SEE ALSO SHEET C4)
  - EXISTING LOT AREA: 21,798 S.F.  
 PROPOSED BUILDING: 17,525 S.F.  
 TOTAL BUILDING COVERAGE: 17,525/21,798 x 100% = 79%  
 OPEN SPACE: (21,798 - 17,525 S.F.)/21,798 S.F. x 100 = 20%
  - ALL CONDITIONS ON THIS PLAN SHALL REMAIN IN EFFECT IN PERPETUITY PURSUANT TO THE REQUIREMENTS OF THE SITE PLAN REVIEW REGULATIONS. STATEMENT REQUIRED PER SECTION 2.13.3 OF THE SITE PLAN REGULATIONS SHALL BE INCLUDED ON THE SITE PLAN TO BE RECORDED.
  - IF BLASTING IS REQUIRED, A BLASTING PLAN WILL BE SUBMITTED TO THE CITY OF PORTSMOUTH FOR REVIEW AND APPROVAL (PRIOR TO ANY BLASTING).
  - EXTERIOR LIGHTING SHALL CONFORM TO THE STANDARDS IN SEC. 10.1140 OF THE CITY OF PORTSMOUTH ZONING ORDINANCE AND ARTICLE 10 OF THE SITE PLAN REVIEW REGULATIONS, INCLUDING PREVENTION OF LIGHT TRESPASS AND GLARE.
  - A CONSTRUCTION MANAGEMENT MITIGATION PLAN (CMMP) SHALL BE PREPARED FOR REVIEW AND APPROVAL BY THE CITY ATTORNEY AND PLANNING DEPARTMENT PRIOR TO THE ISSUANCE OF A BUILDING PERMIT. THE PLAN SHALL INCLUDE AN ACTION PLAN FOR THE DISPOSAL OF ANY CONTAMINATED MATERIALS ENCOUNTERED DURING CONSTRUCTION.
  - ALL SNOW SHALL BE REMOVED FROM THE SITE AND DISPOSED OF OFF SITE IN CONJUNCTION WITH CITY REMOVAL OPERATIONS.
  - 46-64 MAPLEWOOD TRASH DISPOSAL IS AT 30 MAPLEWOOD DUMPSTER, WITH PERMISSION. SEE RCRD 5807/2635.
  - SITE IS VESTED TO DECEMBER 2013 ZONING.

**TAX MAP 125 LOT 2A**  
**46-64 MAPLEWOOD AVENUE**  
**PORTSMOUTH, N.H.**

NO.	DESCRIPTION	DATE
3	INTERIOR LAYOUT, NOTES 3 & 7, CU CRITERIA	1/12/18
2	INTERIOR LAYOUT, TABLE	12/19/17
1	REVISED INTERIOR	10/17/17
0	ISSUED FOR COMMENT	6/19/17

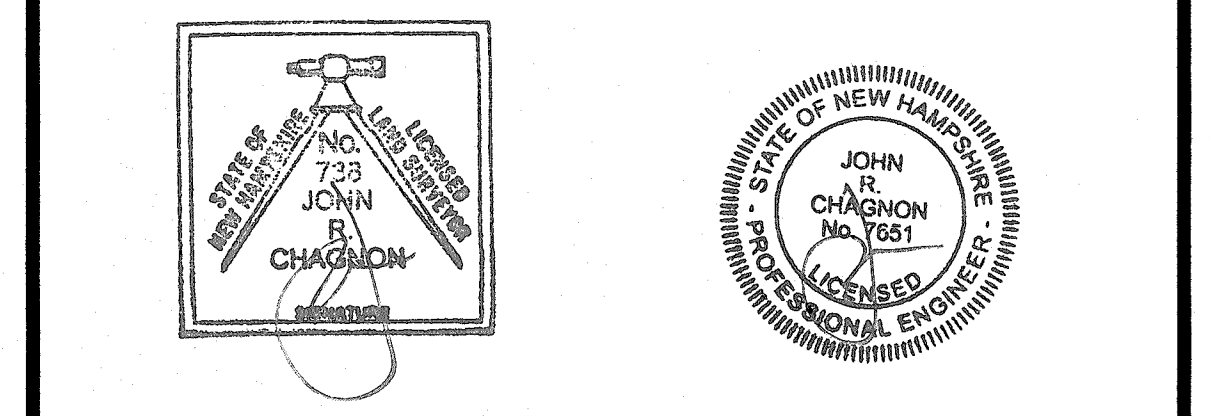

SCALE: 1" = 10'  
JUNE 2017  
**SITE PLAN**  
**FIRST FLOOR LEVEL**  
**C3**

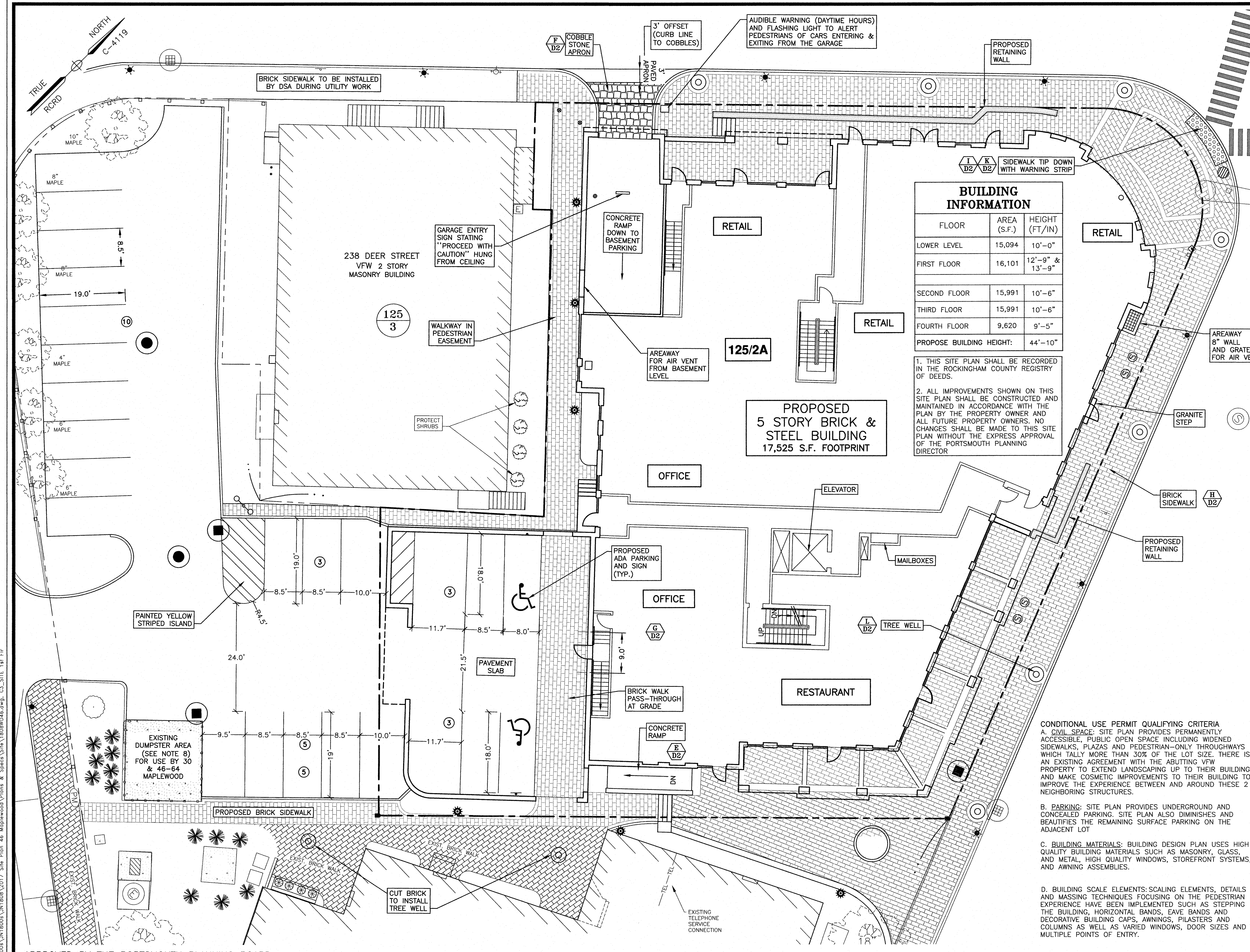

**BUILDING INFORMATION**

FLOOR	AREA (S.F.)	HEIGHT (FT./IN)
LOWER LEVEL	15,094	10'-0"
FIRST FLOOR	16,101	12'-9" & 13'-9"
SECOND FLOOR	15,991	10'-6"
THIRD FLOOR	15,991	10'-6"
FOURTH FLOOR	9,620	9'-5"
PROPOSE BUILDING HEIGHT:		44'-10"

1. THIS SITE PLAN SHALL BE RECORDED IN THE ROCKINGHAM COUNTY REGISTRY OF DEEDS.  
 2. ALL IMPROVEMENTS SHOWN ON THIS SITE PLAN SHALL BE CONSTRUCTED AND MAINTAINED IN ACCORDANCE WITH THE PLAN BY THE PROPERTY OWNER AND ALL FUTURE PROPERTY OWNERS. NO CHANGES SHALL BE MADE TO THIS SITE PLAN WITHOUT THE EXPRESS APPROVAL OF THE PORTSMOUTH PLANNING DIRECTOR

**CONDITIONAL USE PERMIT QUALIFYING CRITERIA**

A. CIVIL SPACE: SITE PLAN PROVIDES PERMANENTLY ACCESSIBLE, PUBLIC OPEN SPACE INCLUDING WIDENED SIDEWALKS, PLAZAS AND PEDESTRIAN-ONLY THROUGHWAYS WHICH TALLY MORE THAN 30% OF THE LOT SIZE. THERE IS AN EXISTING AGREEMENT WITH THE ABUTTING VFW PROPERTY TO EXTEND LANDSCAPING UP TO THEIR BUILDING AND MAKE COSMETIC IMPROVEMENTS TO THEIR BUILDING TO IMPROVE THE EXPERIENCE BETWEEN AND AROUND THESE 2 NEIGHBORING STRUCTURES.

B. PARKING: SITE PLAN PROVIDES UNDERGROUND AND CONCEALED PARKING. SITE PLAN ALSO DIMINISHES AND BEAUTIFIES THE REMAINING SURFACE PARKING ON THE ADJACENT LOT

C. BUILDING MATERIALS: BUILDING DESIGN PLAN USES HIGH QUALITY BUILDING MATERIALS SUCH AS MASONRY, GLASS, AND METAL, HIGH QUALITY WINDOWS, STOREFRONT SYSTEMS, AND AWNING ASSEMBLIES.

D. BUILDING SCALE ELEMENTS: SCALING ELEMENTS, DETAILS AND MASSING TECHNIQUES FOCUSING ON THE PEDESTRIAN EXPERIENCE HAVE BEEN IMPLEMENTED SUCH AS STEPPING THE BUILDING, HORIZONTAL BANDS, EAVE BANDS AND DECORATIVE BUILDING CAPS, AWNINGS, PILASTERS AND COLUMNS AS WELL AS VARIOUS WINDOWS, DOOR SIZES AND MULTIPLE POINTS OF ENTRY.

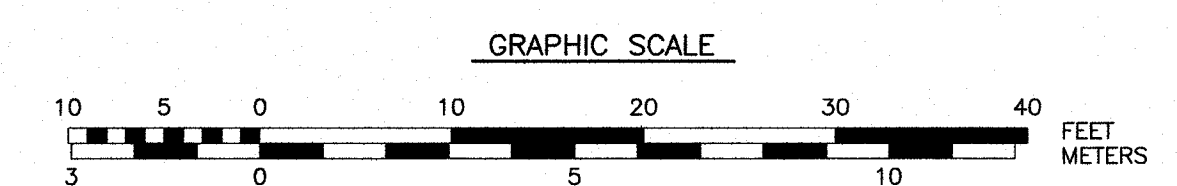

APPROVED BY THE PORTSMOUTH PLANNING BOARD  
CHAIRMAN \_\_\_\_\_ DATE \_\_\_\_\_

J:\JOBS\18003\18003\_18003\_2017\_Site Plan 46 Maplewood\Plans & Specs\Site\18003\046.dwg, C3\_SITE 1st Fl.



J:\JOB5\UNT1808\UNT1808\UNT1808 2017 Site Plan 45 Maplewood\Plans & Specs\Site\1808W046.dwg - CA SITE BSMT



**AMBIT ENGINEERING, INC.**  
 Civil Engineers & Land Surveyors  
 200 Griffin Road, Unit 3  
 Portsmouth, N.H. 03801-7114  
 Tel (603) 430-9292  
 Fax (603) 436-2315

**NOTES:**

- 1) THE CONTRACTOR SHALL NOTIFY DIG SAFE AT 1-888-DIG-SAFE (1-888-344-7233) AT LEAST 72 HOURS PRIOR TO COMMENCING ANY EXCAVATION ON PUBLIC OR PRIVATE PROPERTY.
- 2) UNDERGROUND UTILITY LOCATIONS ARE BASED UPON BEST AVAILABLE EVIDENCE AND ARE NOT FIELD VERIFIED. LOCATING AND PROTECTING ANY ABOVEGROUND OR UNDERGROUND UTILITIES IS THE SOLE RESPONSIBILITY OF THE CONTRACTOR AND/OR THE OWNER. UTILITY CONFLICTS SHOULD BE REPORTED AT ONCE TO THE DESIGN ENGINEER.
- 3) CONTRACTOR SHALL INSTALL AND MAINTAIN EROSION CONTROL MEASURES IN ACCORDANCE WITH THE "NEW HAMPSHIRE STORMWATER MANUAL, VOLUME 3, EROSION AND SEDIMENT CONTROLS DURING CONSTRUCTION. (NHDES DECEMBER 2008).
- 4) PRIOR TO CONSTRUCTION, IF NEEDED, A CONSTRUCTION SITE DEWATERING PLAN WILL BE SUBMITTED TO THE CITY PUBLIC WORKS DEPARTMENT FOR REVIEW AND APPROVAL. SAID PLAN TO OUTLINE METHODS TO PROPERTY DEAL WITH ANY GROUNDWATER ENCOUNTERED OR EXPECTED TO BE ENCOUNTERED DURING CONSTRUCTION.
- 5) GARAGE EGRESS TO BE COMPLIANT WITH CURRENT IBC. FINAL DESIGN APPROVAL BY THE PORTSMOUTH BUILDING INSPECTOR IS REQUIRED.
- 6) VENTILATION DESIGN TO BE COMPLIANT WITH CURRENT IBC; SEE PRELIMINARY VENT LOCATIONS. FINAL APPROVAL BY THE PORTSMOUTH BUILDING INSPECTOR IS REQUIRED.
- 7) CHAPTER 7 PROTECTED OPENINGS EXHIBIT SUBMITTED FOR REVIEW - ALSO SEE EASEMENT PLAN. FINAL APPROVAL REQUIRED BEFORE BUILDING PERMIT.
- 8) STREET FEATURES SHOWN FOR REFERENCE ONLY - SEE SHEET C3 FOR DETAIL.
- 9) GENERATOR INTAKE AIR AND EXHAUST TO BE DESIGNED BY QUALIFIED HVAC ENGINEERING PRIOR TO BUILDING PERMIT. FINAL APPROVAL REQUIRED.
- 10) VARIANCE FOR STACKED PARKING GRANTED BY THE PORTSMOUTH ZBA ON JUNE 27, 2017.

TAX MAP 125 LOT 2A  
 46-64 MAPLEWOOD AVENUE  
 PORTSMOUTH, N.H.

NO.	DESCRIPTION	DATE
3	REVISED INTERIOR, NOTE 4 & 10	1/12/18
2	REVISED INTERIOR, ADDED VENTILATION	12/19/17
1	REVISED INTERIOR	10/17/17
0	ISSUED FOR COMMENT	6/19/17

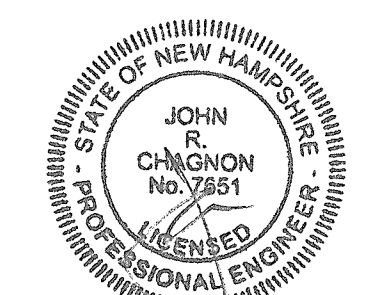
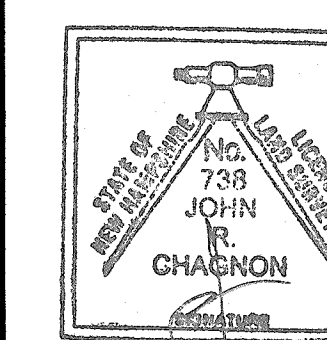

SCALE: 1" = 10'

JUNE 2017

**SITE PLAN  
 BASEMENT LEVEL**

**C4**

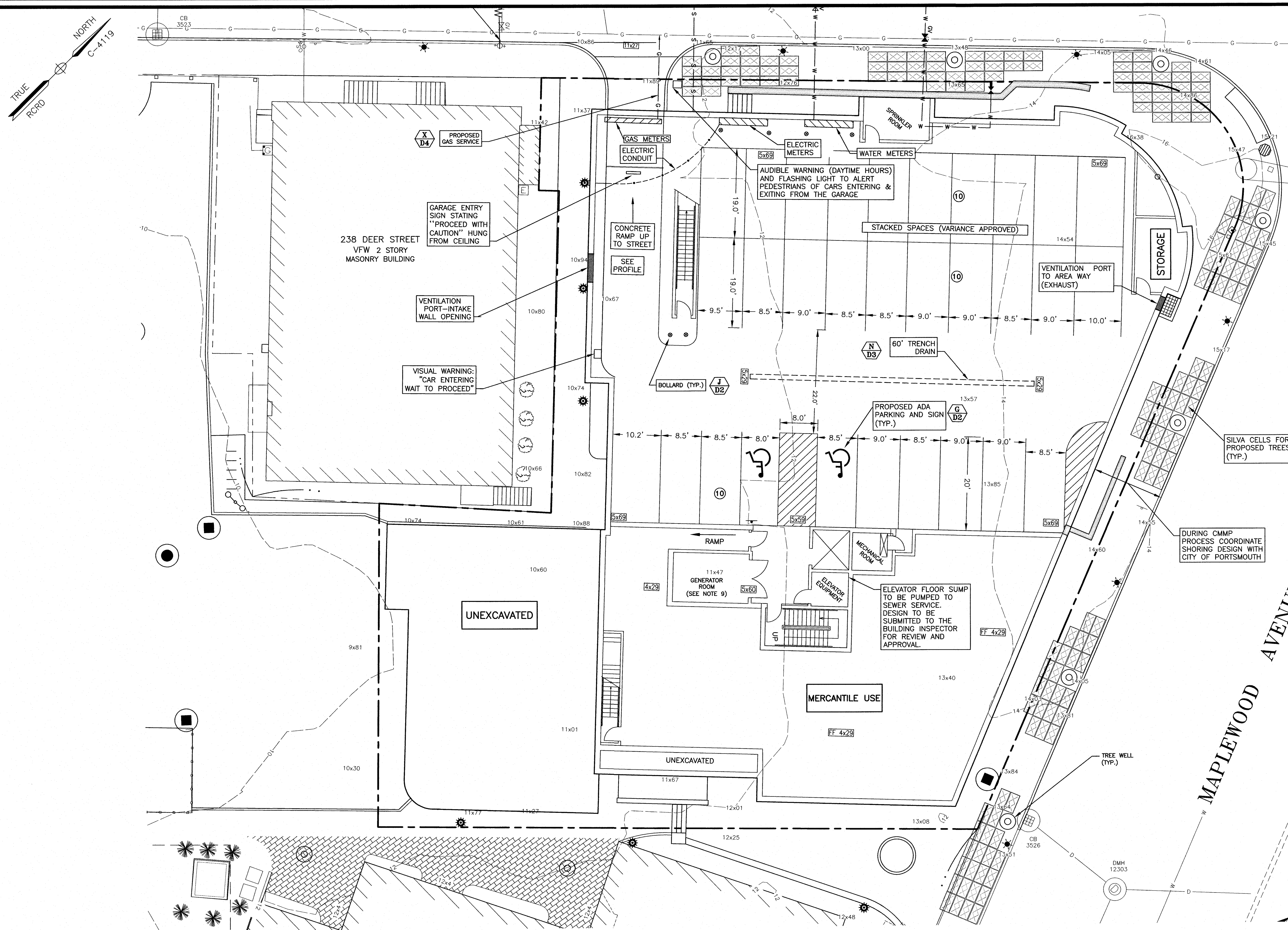

APPROVED BY THE PORTSMOUTH PLANNING BOARD

CHAIRMAN \_\_\_\_\_ DATE \_\_\_\_\_



**AMBIT ENGINEERING, INC.**  
Civil Engineers & Land Surveyors

200 Griffin Road, Unit 3  
Portsmouth, N.H. 03801-7114  
Tel (603) 430-9292  
Fax (603) 436-2315

**NOTES:**

- THE CONTRACTOR SHALL NOTIFY DIG SAFE AT 1-888-DIG-SAFE (1-888-344-7233) AT LEAST 72 HOURS PRIOR TO COMMENCING ANY EXCAVATION ON PUBLIC OR PRIVATE PROPERTY.
- UNDERGROUND UTILITY LOCATIONS ARE BASED UPON BEST AVAILABLE EVIDENCE AND ARE NOT FIELD VERIFIED. LOCATING AND PROTECTING ANY ABOVEGROUND OR UNDERGROUND UTILITIES IS THE SOLE RESPONSIBILITY OF THE CONTRACTOR AND/OR THE OWNER. UTILITY CONFLICTS SHOULD BE REPORTED AT ONCE TO THE DESIGN ENGINEER.
- CONTRACTOR SHALL INSTALL AND MAINTAIN EROSION CONTROL MEASURES IN ACCORDANCE WITH THE "NEW HAMPSHIRE STORMWATER MANUAL, VOLUME 3, EROSION AND SEDIMENT CONTROLS DURING CONSTRUCTION." (NHDES DECEMBER 2008).
- SEWER LOADING:  
21 RESIDENTIAL UNITS: 3,150 GPD (150 GPD/UNIT)  
OFFICE RETAIL: 1,800 GPD (15 GPD/100 S.F.)  
RESTAURANT: 2,000 GPD (50 SEATS X 40 GPH/SEAT)  
TOTAL FLOW: 6,950 GPD
- FIRE SPRINKLER SYSTEM:  
PRIOR TO OBTAINING BUILDING PERMIT A SPRINKLER DESIGN PLAN WILL BE SUBMITTED TO THE CITY FOR REVIEW AND APPROVAL. PROVIDE A SPRINKLER CONNECTION (PER FIRE DEPARTMENT SPECIFICATIONS) ON DEER STREET SIDE OF BUILDING. PROVIDE KNEX BOX AT ACCESSIBLE EXTERIOR LOCATION. COORDINATE INSTALLATION WITH PORTSMOUTH FIRE DEPARTMENT.
- EACH ADDITIONAL RESTAURANT PROPOSED IN THIS STRUCTURE SHALL INSTALL ITS OWN EXTERNAL GREASE TRAP. GREASE TRAPS SERVICE FREQUENCY SHALL BE BASED UPON ACTUAL LOADS IMPOSED BY THE PARTICIPATING RESTAURANT.
- BUILDING WILL HAVE ONE WATER METER - USES WILL BE SUB-METERED BY OWNER.
- STREET LIGHTS TO BE REPLACED WITH CURRENT CITY STANDARD (DUCTILE IRON). DEVELOPER SHALL COORDINATE WITH DPW ON THE FINAL ROUTING OF THE ELECTRICAL CONDUIT TO THE STREET LIGHTS.
- THE DEVELOPER SHALL PAY THE CAPACITY USE SURCHARGE FOR WATER AND SEWER APPLICABLE TO THE PROPOSED USES.
- OVERHEAD GARAGE DOORS SHALL BE SET TO AUTOMATICALLY OPEN IN THE EVENT THAT THE FIRE ALARM IS ACTIVATED. THE APPLICANT SHALL HAVE A COMMUNICATIONS SITE SURVEY CONDUCTED BY A MOTOROLA COMMUNICATIONS CARRIER APPROVED BY THE CITY'S COMMUNICATIONS DIVISION. THE RADIO COMMUNICATIONS CARRIER MUST BE FAMILIAR AND CONVERSANT WITH THE PORTSMOUTH POLICE AND FIRE RADIO SYSTEMS CONFIGURATION. IF THE SITE SURVEY INDICATES THAT IT IS NECESSARY TO INSTALL A SIGNAL REPEATER EITHER ON OR NEAR THE PROPOSED PROJECT, THOSE COSTS SHALL BE THE RESPONSIBILITY OF THE PROPERTY OWNER. THE PROPERTY OWNER WILL BE REQUIRED TO MAINTAIN ANY INSTALLED EQUIPMENT. THE PROPERTY OWNER SHALL BE RESPONSIBLE TO PAY FOR THE SITE SURVEY WHETHER OR NOT THE SURVEY INDICATES THAT EQUIPMENT IS NECESSARY. THE OWNER SHALL COORDINATE WITH THE SUPERVISOR OF RADIO COMMUNICATIONS FOR THE CITY. THE SURVEY SHALL BE COMPLETED AND ANY REQUIRED EQUIPMENT INSTALLED, TESTED, AND ACCEPTED PRIOR TO THE ISSUANCE OF A CERTIFICATE OF OCCUPANCY.
- EXISTING 6" FIRE SERVICE TO BE RE-USED FOR RELOCATED HYDRANT (ADD A GATE VALVE).
- EVERSOURCE WORK ORDER: 3040225
- CONTRACTOR TO WORK WITH CITY TO IDENTIFY LOCATIONS OF VFW SEWER CONNECTION, AND IF SERVICE IS TO THE SEWER MAIN TO BE ABANDONED, OWNER WILL PAY FAIR SHARE COST TO CONNECT TO BRICK BOX SEWER.

**TAX MAP 125 LOT 2A**  
**46-64 MAPLEWOOD AVENUE**  
**PORTSMOUTH, N.H.**

3	UTILITIES, NOTES 6 & 13	1/12/18
2	UTILITIES	12/19/17
1	UTILITIES	10/17/17
0	ISSUED FOR COMMENT	6/19/17
NO.	DESCRIPTION	DATE
REVISIONS		

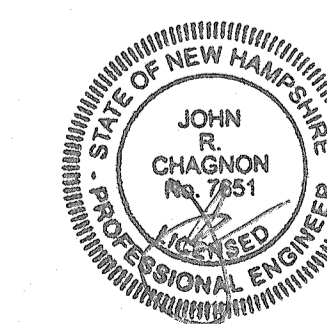

SCALE: 1" = 20'

JUNE 2017

UTILITY PLAN

C5

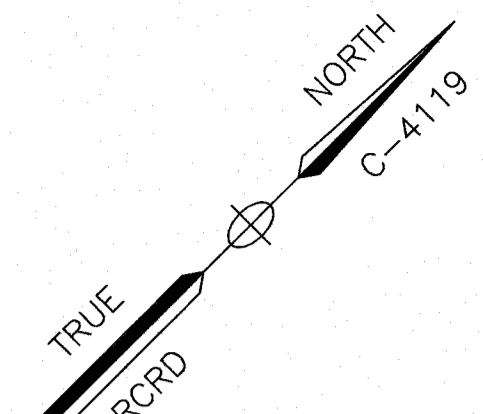

**DRAIN STRUCTURE TABLE**

STRUCTURE	RIM ELEV.	INV. ELEV. IN	INV. ELEV. OUT	PIPE SIZE & TYPE
CB 3522	10.09	7.48±	-	12" RCP (NE)
CB 3523	9.49	6.29	-	12" (NW)
DMH 3540	10.78	NA	-	18" RCP (NE) 36" (SW)
DMH 3541	10.23	7.48± 7.48± 2.07	-	12" RCP (SW) 12" RCP (SE) 36" (S)
DMH 3542	9.41	1.93 2.58	-	36" 36"

**SEWER STRUCTURE TABLE**

STRUCTURE	RIM ELEV.	INV. ELEV. IN	INV. ELEV. OUT	PIPE SIZE & TYPE
1491	10.10	0.60 0.50	-	21" VC (SE) 14" VC (S)
1492	11.17	0.51 3.52 ?	-	21" VC (NE) 6" PVC 21" VC
1493	10.04	-1.33 2.49	-	48" BOX SEWER 6" VC (NE)
1499	15.77	2.39 -1.89	-	6" VC (NW) 48" BOX SEWER
1500	14.14	-1.89 7.31	-	48" BOX SEWER 6" VC (SW)
2305	10.87	-1.20	-	48" VC
5317	8.24	1.29 1.18	-	14" AC (ESE) 14" AC (NW)
5318	9.85	0.60 0.40	-	21" VC (SE) 21" VC (NW)

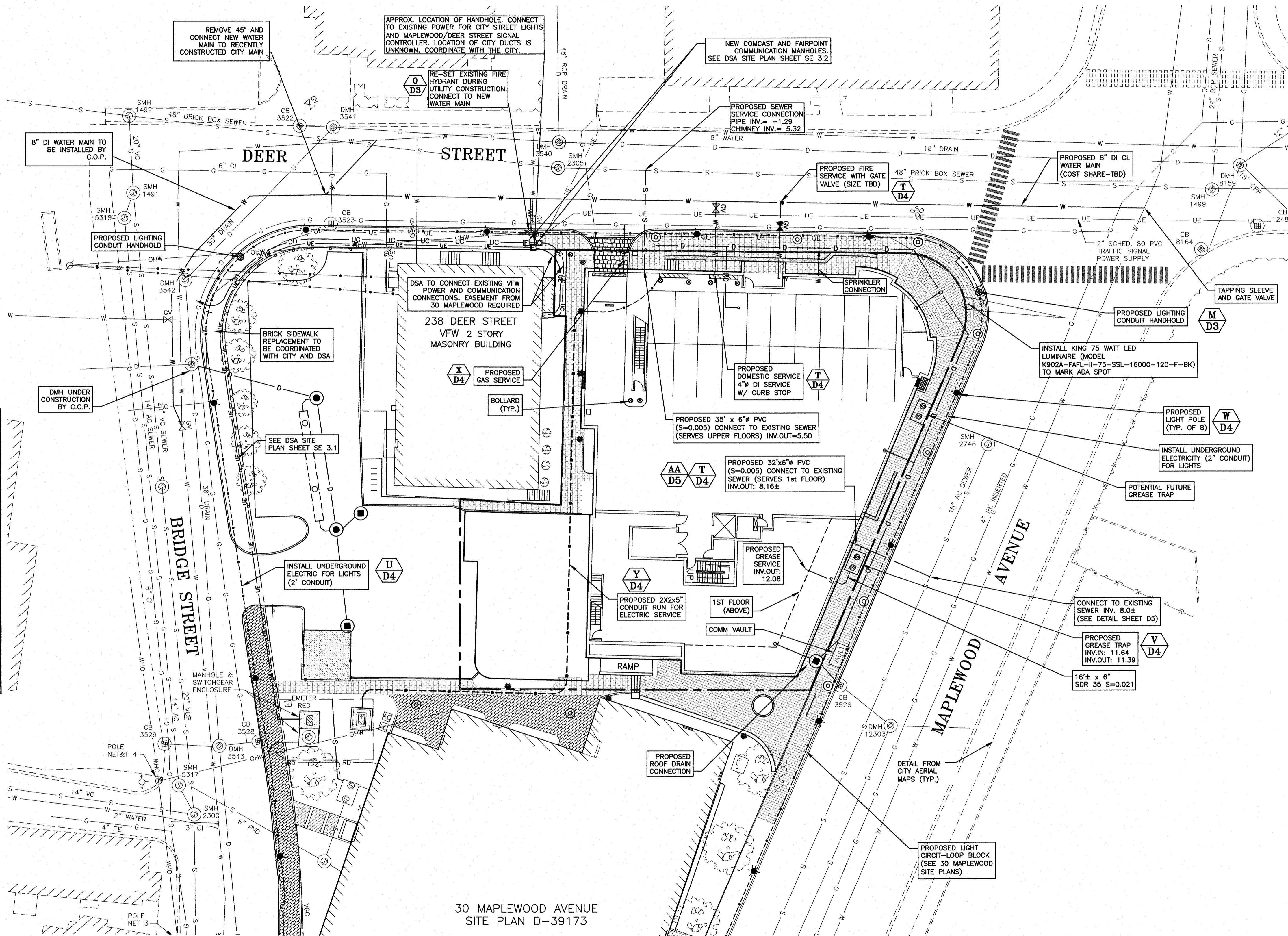

APPROVED BY THE PORTSMOUTH PLANNING BOARD

CHAIRMAN \_\_\_\_\_ DATE \_\_\_\_\_

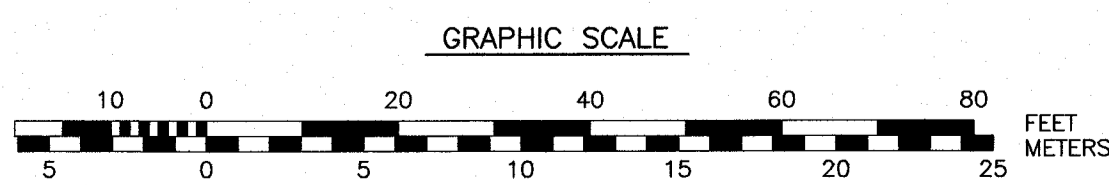

J:\G0851\UN1808\UN1808\2017 Site Plan 46 Maplewood\Plans & Specs\Site\808W046.dwg, C5\_UTILITY

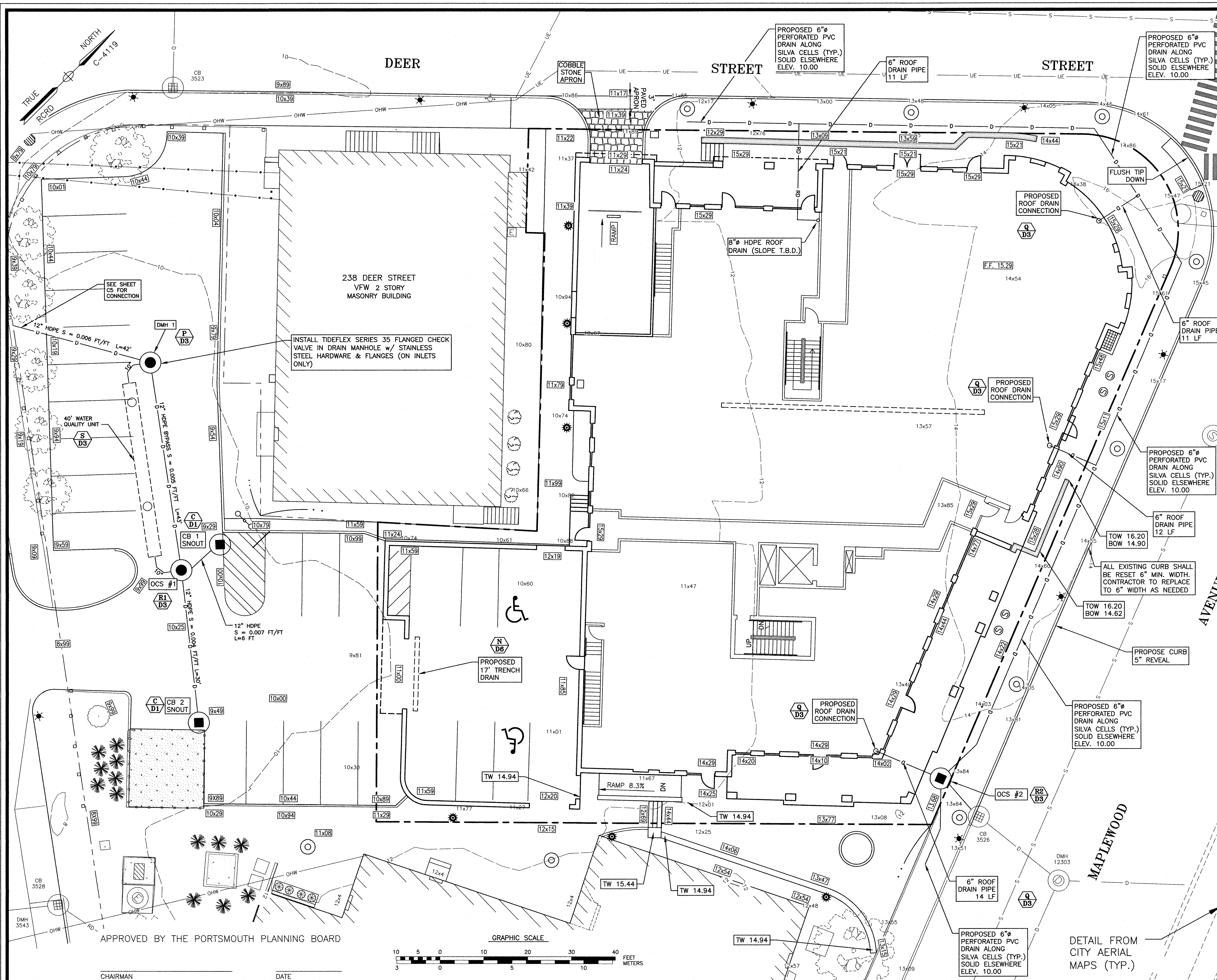

**AMBIT ENGINEERING, INC.**  
 Civil Engineers & Land Surveyors  
 200 Griffin Road, Unit 3  
 Portsmouth, N.H. 03801-7114  
 Tel (603) 430-0292  
 Fax (603) 436-2315

- NOTES:**
- THE CONTRACTOR SHALL NOTIFY DIG SAFE AT 1-888-DIG-SAFE (1-888-344-7233) AT LEAST 72 HOURS PRIOR TO COMMENCING ANY EXCAVATION ON PUBLIC OR PRIVATE PROPERTY.
  - UNDERGROUND UTILITY LOCATIONS ARE BASED UPON BEST AVAILABLE EVIDENCE AND ARE NOT FIELD VERIFIED. LOCATING AND PROTECTING ANY ABOVEGROUND OR UNDERGROUND UTILITIES IS THE SOLE RESPONSIBILITY OF THE CONTRACTOR AND/OR THE OWNER. UTILITY CONFLICTS SHOULD BE REPORTED AT ONCE TO THE DESIGN ENGINEER.
  - CONTRACTOR SHALL INSTALL AND MAINTAIN EROSION CONTROL MEASURES IN ACCORDANCE WITH THE "NEW HAMPSHIRE STORMWATER MANUAL, VOLUME 3, EROSION AND SEDIMENT CONTROLS DURING CONSTRUCTION. (NHDES DECEMBER 2008).
  - BUILDING ROOF WILL BE DRAINED INTERNALLY WITH CONNECTIONS AS SHOWN.
  - FOUNDATION TO BE DESIGNED (BY OTHERS) TO BE WATER TIGHT AT THE BASEMENT LEVEL. ANY GROUNDWATER DISCHARGES PROPOSED FOR THE FINAL DEWATERING DESIGN (IF ANY) SHALL BE SUBMITTED TO THE CITY FOR REVIEW AND APPROVAL OF CAPACITY.

**PROPOSED DRAIN STRUCTURE TABLE**

STRUCTURE	PIPE	PIPE LENGTH, PIPE SLOPE	INV. ELEV. IN	INV. ELEV. OUT	SUMP INV. ELEV.	DOWN STREAM STRUCTURE
CATCH BASIN CB 2	12" HDPE	L = 30 L.F., SLOPE = 0.004 ft./ft.	9.49	5.40	2.40	DMH 2
CATCH BASIN CB 1	12" HDPE	L = 6 L.F., SLOPE = 0.007 ft./ft.	9.29	5.33	2.33	DMH 2
ROOF DRAIN	6" PVC	L = VARIES, SLOPE = 0.01 ft./ft.	-	-	-	DMH 2
OUTLET CONTROL STRUCTURE (OCS #1)	12" HDPE	L = 44 L.F., SLOPE = 0.005 ft./ft.	9.78±	6.17 (6") 5.33 (12")	WEIR ELEV. 5.60	DMH 1
DRAIN MANHOLE DMH 1	12" HDPE	L = 41 L.F., SLOPE = 0.006 ft./ft.	9.78±	5.23 (12") 4.29 (10")	-	DMH 1A
DRAIN MANHOLE DMH 1A (FUTURE/EXIST.)	12" HDPE	L = 41 L.F., SLOPE = 0.006 ft./ft.	TBD	4.67 (12") 2.67 (36")	-	DMH 3542
OUTLET CONTROL STRUCTURE (OCS #2)	12" HDPE	L = 41 L.F., SLOPE = 0.006 ft./ft.	9.78±	10.0 (6") 10.0 (6" RD)	WEIR ELEV. 12.00	CB 3526

NOTE: PROVIDE CHECK VALVES IN DRAIN MANHOLE #1 TO PREVENT FLOW BACK INTO SYSTEM.

**TAX MAP 125 LOT 2A**  
**46-64 MAPLEWOOD AVENUE**  
**PORTSMOUTH, N.H.**

NO.	DESCRIPTION	DATE
3	NOTE 5, CURB REVEAL	1/12/18
2	GRADING	12/19/17
1	PLAN DATUM	10/17/17
0	ISSUED FOR COMMENT	6/19/17

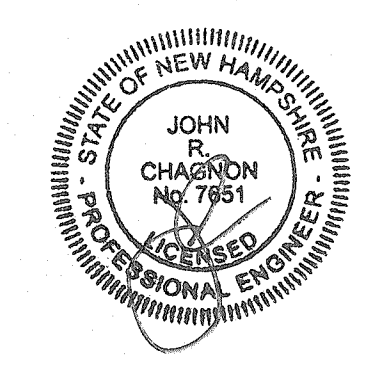

SCALE: 1" = 10' JUNE 2017

**GRADING AND DRAINAGE PLAN**  
**C6**

J:\0881\1818006\1818006\_1818006\1818006\1818006\1818006\1818006\1818006\1818006\1818006\1818006\1818006\1818006\1818006.dwg, PROFILE

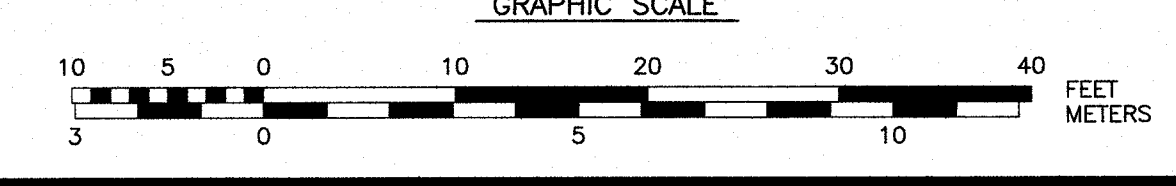
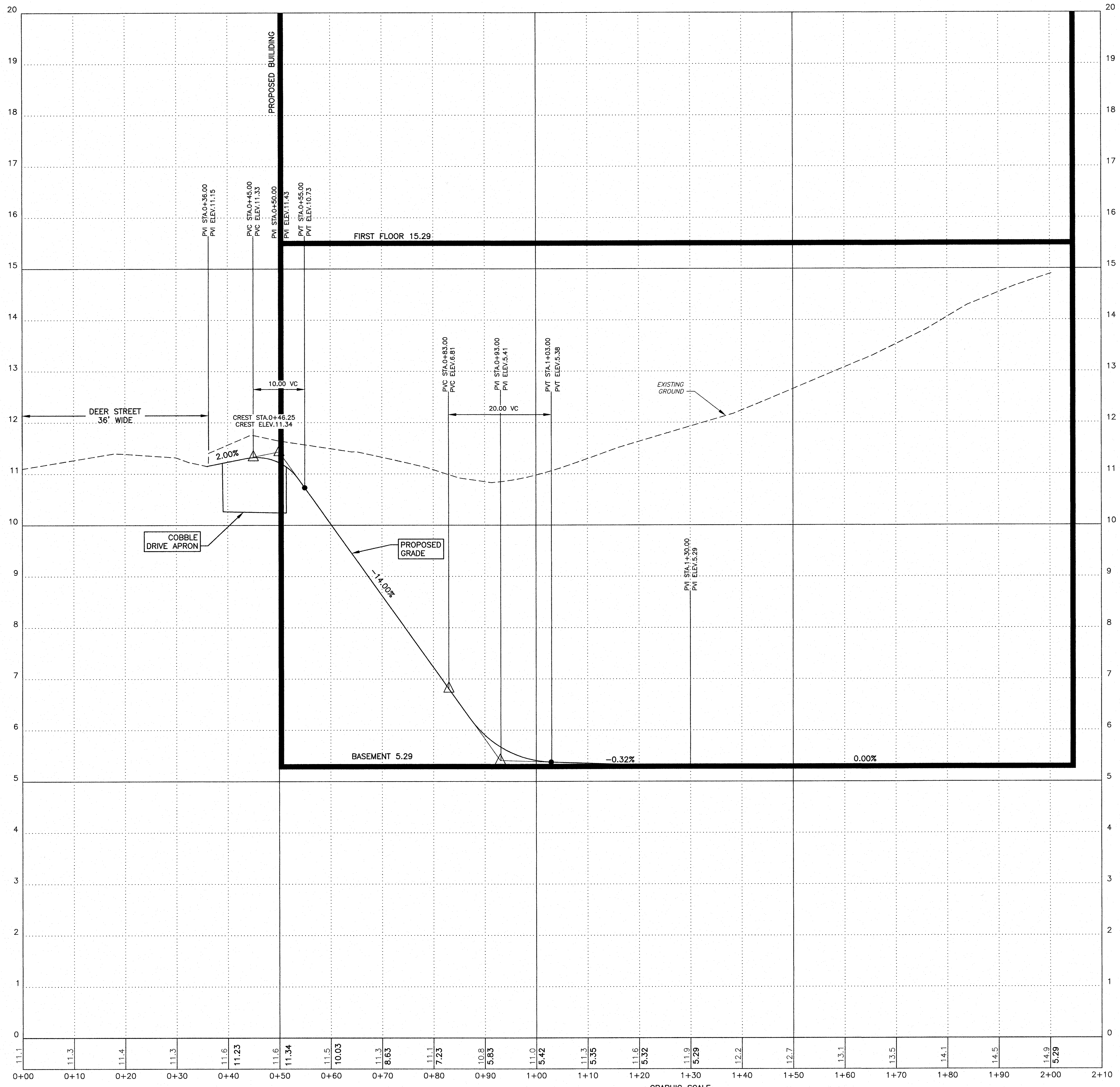
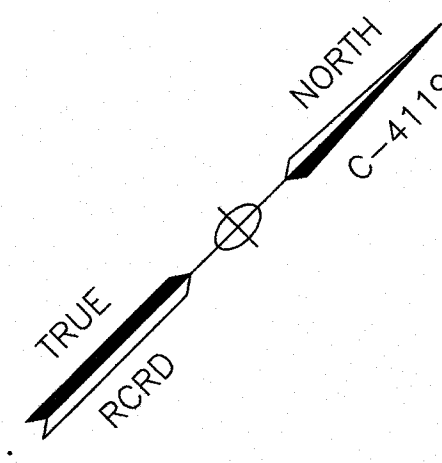

**AMBIT ENGINEERING, INC.**  
Civil Engineers & Land Surveyors

200 Griffin Road, Unit 3  
Portsmouth, N.H. 03801-7114  
Tel (603) 430-9282  
Fax (603) 436-2315

- NOTES:**
- 1) THE CONTRACTOR SHALL NOTIFY DIG SAFE AT 1-888-DIG-SAFE (1-888-344-7233) AT LEAST 72 HOURS PRIOR TO COMMENCING ANY EXCAVATION ON PUBLIC OR PRIVATE PROPERTY.
  - 2) UNDERGROUND UTILITY LOCATIONS ARE BASED UPON BEST AVAILABLE EVIDENCE AND ARE NOT FIELD VERIFIED. LOCATING AND PROTECTING ANY ABOVEGROUND OR UNDERGROUND UTILITIES IS THE SOLE RESPONSIBILITY OF THE CONTRACTOR AND/OR THE OWNER. UTILITY CONFLICTS SHOULD BE REPORTED AT ONCE TO THE DESIGN ENGINEER.
  - 3) CONTRACTOR SHALL INSTALL AND MAINTAIN EROSION CONTROL MEASURES IN ACCORDANCE WITH THE "NEW HAMPSHIRE STORMWATER MANUAL, VOLUME 3, EROSION AND SEDIMENT CONTROLS DURING CONSTRUCTION. (NHDES DECEMBER 2008).

**GARAGE PROFILE**  
SCALE: 1" = 10' (HOR.)  
1" = 1' (VERT.)

**GARAGE PLAN**  
SEE SITE PLAN BASEMENT LEVEL FOR PLAN VIEW

**TAX MAP 125 LOT 2A  
46-64 MAPLEWOOD AVENUE  
PORTSMOUTH, N.H.**

NO.	DESCRIPTION	DATE
<b>REVISIONS</b>		
2	PROFILE REVISED	1/16/18
1	PROFILE CHANGED TO 10:1	10/17/17
0	ISSUED FOR COMMENT	8/22/17

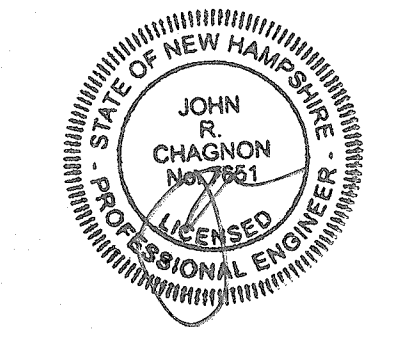

SCALE: 1" = 10'      JUNE 2017

**PROFILE  
GARAGE RAMP**

**P1**

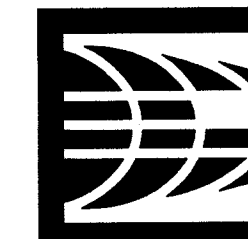

**AMBIT ENGINEERING, INC.**  
Civil Engineers & Land Surveyors

200 Griffin Road, Unit 3  
Portsmouth, N.H. 03801-7114  
Tel (603) 430-9282  
Fax (603) 436-2315

**LUMINAIRE SCHEDULE**

SYMBOL	LABEL	QTY.	CATALOG NUMBER	DESCRIPTION	LAMP	NUMBER LAMPS	LUMENS PER LAMP	LIGHT LOSS FACTOR	WATTAGE
☀	A	15	U538008	KLEIN BOLLARD; MOUNTED AT 3FT	LED	1	74	0.9	6
☉	B	2	F0801SHO30805 K X A	RISE SPOT; MOUNTED AT 30FT	LED	1	746	0.9	11.5
☾	C	42	7000WKONB3017Z277S	KONIAL 17 METAL EXTERIOR WALL SCIENCE WITH DRIVER TO REDUCE OUTPUT; MOUNTED AT 8FT	LED	1	2315.354	0.68	22.2
⊙	D	6	C3LS-DW-13834060-XX	EXTERIOR CYLINDER WALL SCIENCE; MOUNTED AT 10FT	LED	1	1300	0.9	18
☀	G	9	7000WQCLB40H	CIRQUE LARGE SURFACE MOUNT; MOUNTED AT 9.5 FT	LED	1	1042	0.9	22
☀	H	4	XXXXXX	UNKNOWN YARD LIGHT FIXTURE; MOUNTED AT 8 FT	LED	1	1819.715	0.45	10
●	P	8	RS-TUE-177	NEWSTAMP LIGHTING PORTSMOUTH WITH MEDIUM BASE EDISON TYPE A LED LAMPS, 60 WATT EQUIVALENT; MOUNTED AT 10FT	LED	1	5642	0.9	62.6
⊙	2I	1	S3976N UNV 14	SLOT POLE 18 WHITE NEUTRAL 4000K; MOUNTED AT 12FT	LED	1	2789	0.9	74

**Statistics**

Description	Symbol	Avg	Max	Min	Max/Min	Avg/Min
Covered Parking Area	+	3.5 fc	6.2 fc	0.7 fc	8.9:1	5.0:1
Ground	+	1.4 fc	31.9 fc	0.0 fc	N/A	N/A

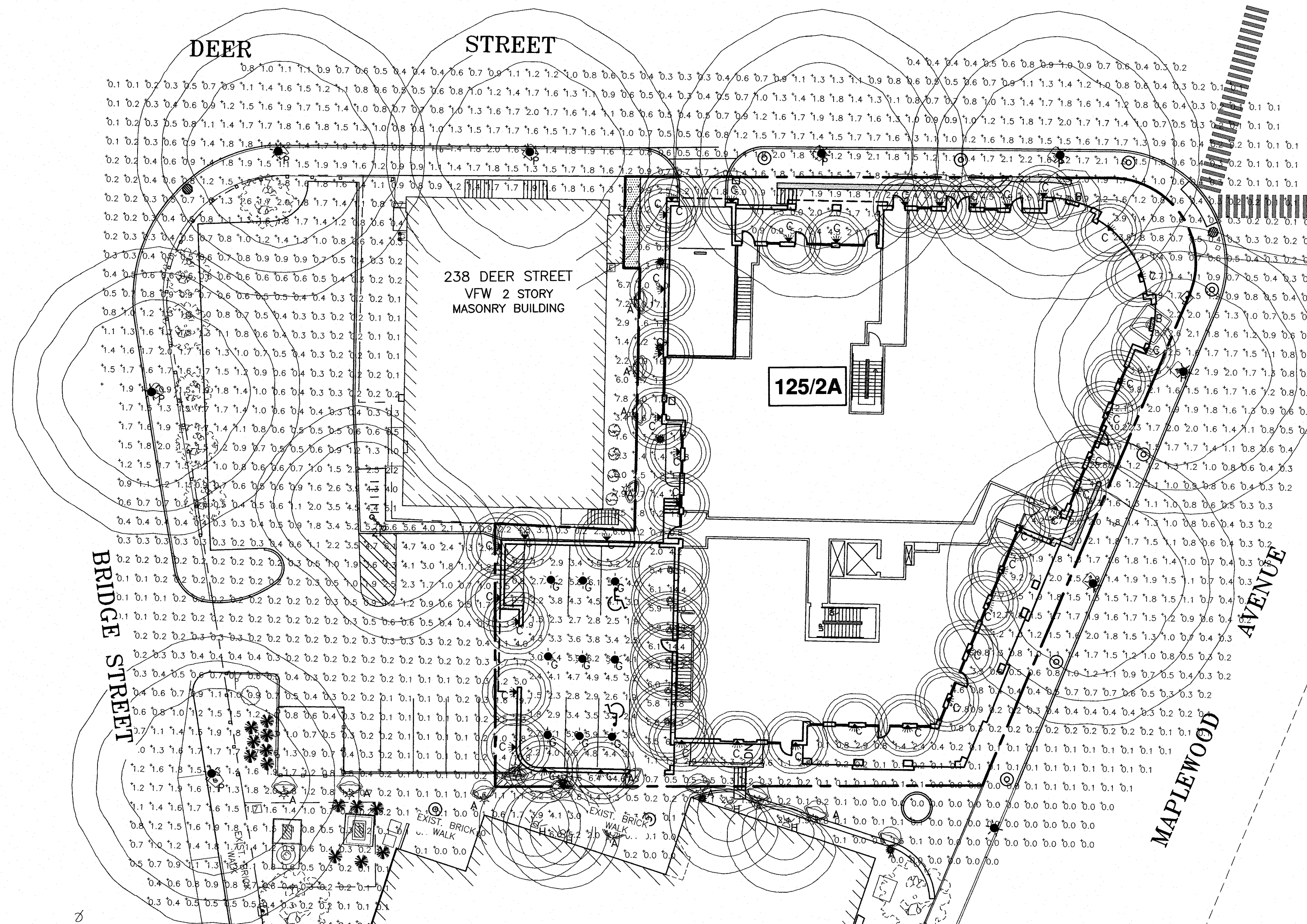
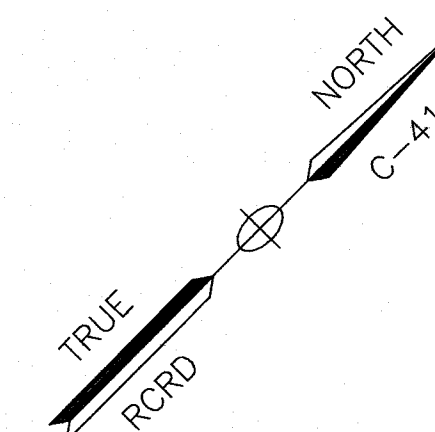

**NOTES:**

- 1) THE CONTRACTOR SHALL NOTIFY DIG SAFE AT 1-888-DIG-SAFE (1-888-344-7233) AT LEAST 72 HOURS PRIOR TO COMMENCING ANY EXCAVATION ON PUBLIC OR PRIVATE PROPERTY.
- 2) UNDERGROUND UTILITY LOCATIONS ARE BASED UPON BEST AVAILABLE EVIDENCE AND ARE NOT FIELD VERIFIED. LOCATING AND PROTECTING ANY ABOVEGROUND OR UNDERGROUND UTILITIES IS THE SOLE RESPONSIBILITY OF THE CONTRACTOR AND/OR THE OWNER. UTILITY CONFLICTS SHOULD BE REPORTED AT ONCE TO THE DESIGN ENGINEER.
- 3) CONTRACTOR SHALL INSTALL AND MAINTAIN EROSION CONTROL MEASURES IN ACCORDANCE WITH THE "NEW HAMPSHIRE STORMWATER MANUAL, VOLUME 3, EROSION AND SEDIMENT CONTROLS DURING CONSTRUCTION. (NHDES DECEMBER 2008).
- 4) POLE MOUNTED LIGHTS SHALL HAVE A MAXIMUM FIXTURE HEIGHT OF 16 FEET.
- 5) ALL LIGHTING SHALL BE SHIELDED TO MINIMIZE LIGHT TRESPASS AND DIRECT GLARE BEYOND THE PROPERTY.
- 6) LIGHTING PLAN PREPARED USING AGI32 SOFTWARE. LIGHTING DESIGN BASED ON .IES FILES THAT WERE LAB-TESTED OR COMPUTER GENERATED. ACTUAL RESULTS MAY VARY DEPENDING ON FIELD CONDITIONS, AREA GEOMETRY OR CHANGES IN ELECTRICAL SUPPLY VOLTAGE.
- 7) LIGHTS SHALL COMPLY WITH ALL LOCAL, STATE, AND FEDERAL REGULATIONS.
- 8) HOURS OF OPERATION ARE ANTICIPATED TO BE 6:00 AM TO 7:00 PM. OUTDOOR LIGHTS SHALL BE EQUIPPED WITH TIMERS TO TURN OFF LIGHTS DURING NON-OPERATIONAL HOURS.
- 9) LIGHTING DESIGN BY VISIBLE LIGHT, INC.  
24 STICKNEY TERRACE  
SUITE 6  
HAMPTON, NH 03842

APPROVED BY THE PORTSMOUTH PLANNING BOARD

CHAIRMAN \_\_\_\_\_ DATE \_\_\_\_\_

**TAX MAP 125 LOT 2A**  
**46-64 MAPLEWOOD AVENUE**  
**PORTSMOUTH, N.H.**

NO.	DESCRIPTION	DATE
1	REMOVED VFW LIGHTS, REVISED CITY LIGHTS	1/12/18
0	ISSUED FOR COMMENT	11/22/17

SCALE: 1" = 20' NOVEMBER 2017

**LIGHTING PLAN**

**L1**

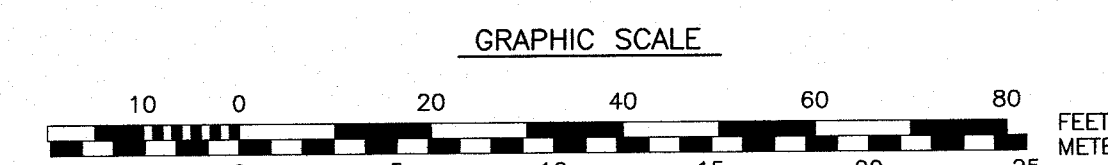





**AMBIT ENGINEERING, INC.**  
Civil Engineers & Land Surveyors

200 Griffin Road, Unit 3  
Portsmouth, N.H. 03801-7114  
Tel (603) 430-0282  
Fax (603) 436-2315

**NOTES:**

- 1) THE CONTRACTOR SHALL NOTIFY DIG SAFE AT 1-888-DIG-SAFE (1-888-344-7233) AT LEAST 72 HOURS PRIOR TO COMMENCING ANY EXCAVATION ON PUBLIC OR PRIVATE PROPERTY.
- 2) UNDERGROUND UTILITY LOCATIONS ARE BASED UPON BEST AVAILABLE EVIDENCE AND ARE NOT FIELD VERIFIED. LOCATING AND PROTECTING ANY ABOVEGROUND OR UNDERGROUND UTILITIES IS THE SOLE RESPONSIBILITY OF THE CONTRACTOR AND/OR THE OWNER. UTILITY CONFLICTS SHOULD BE REPORTED AT ONCE TO THE DESIGN ENGINEER.
- 3) CONTRACTOR SHALL INSTALL AND MAINTAIN EROSION CONTROL MEASURES IN ACCORDANCE WITH THE "NEW HAMPSHIRE STORMWATER MANUAL, VOLUME 3, EROSION AND SEDIMENT CONTROLS DURING CONSTRUCTION. (NHDES DECEMBER 2008).

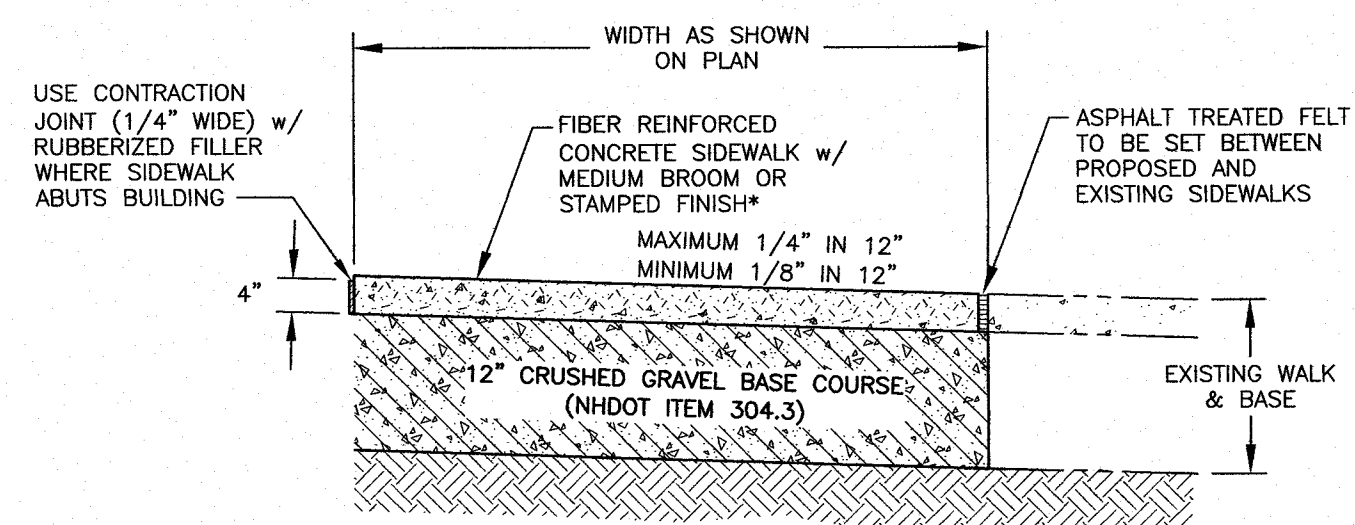

\*FIBER: 100% VIRGIN POLYPROPYLENE SUCH AS GRACE MICROFIBER, ASTM C1116, TYPE 111, PAR.4.1.3 OR EQUAL, APPLIED @ 1 LB. PER C.Y.

**CROSS SECTION**

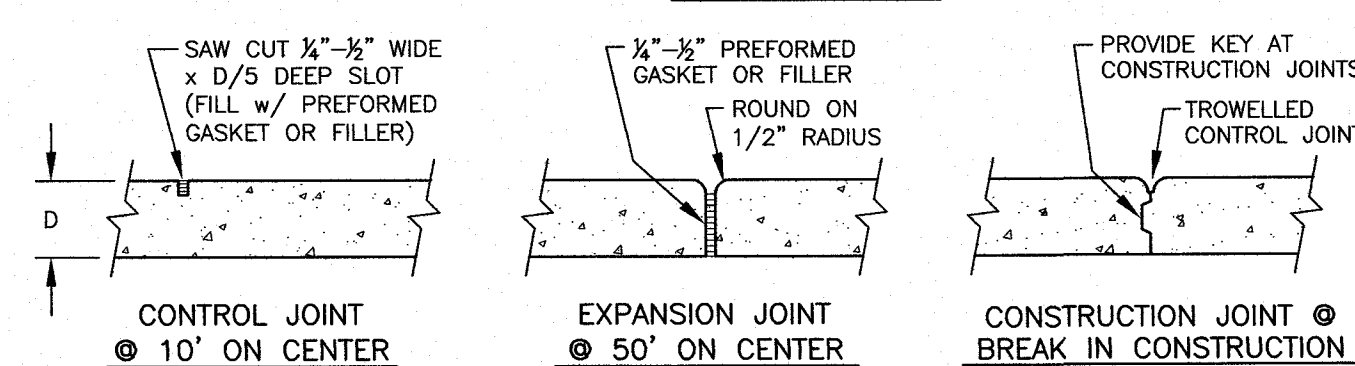

**E PORTLAND CEMENT CONCRETE SIDEWALK**  
C3 NTS

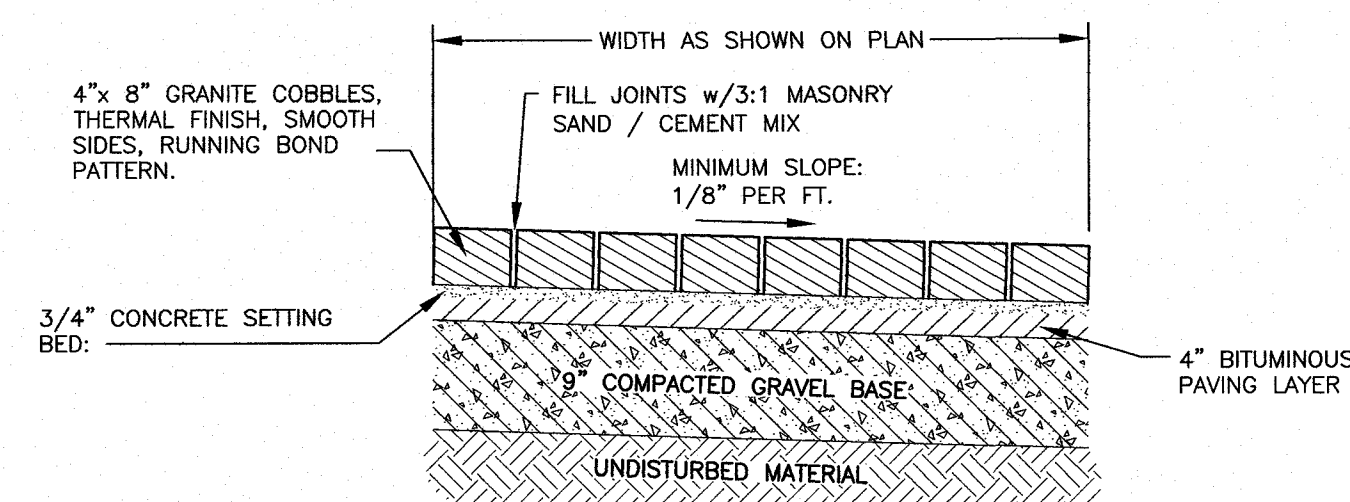

**F COBBLE BAND (APRON)**  
C3 NTS

NOTE: A PORTION OF COBBLE BAND IS IN CITY'S R-D-W. OWNER SHALL KEEP IN GOOD REPAIR AND REPAIR WITHIN 90 DAYS NOTICE OF DEFECT FROM THE CITY.

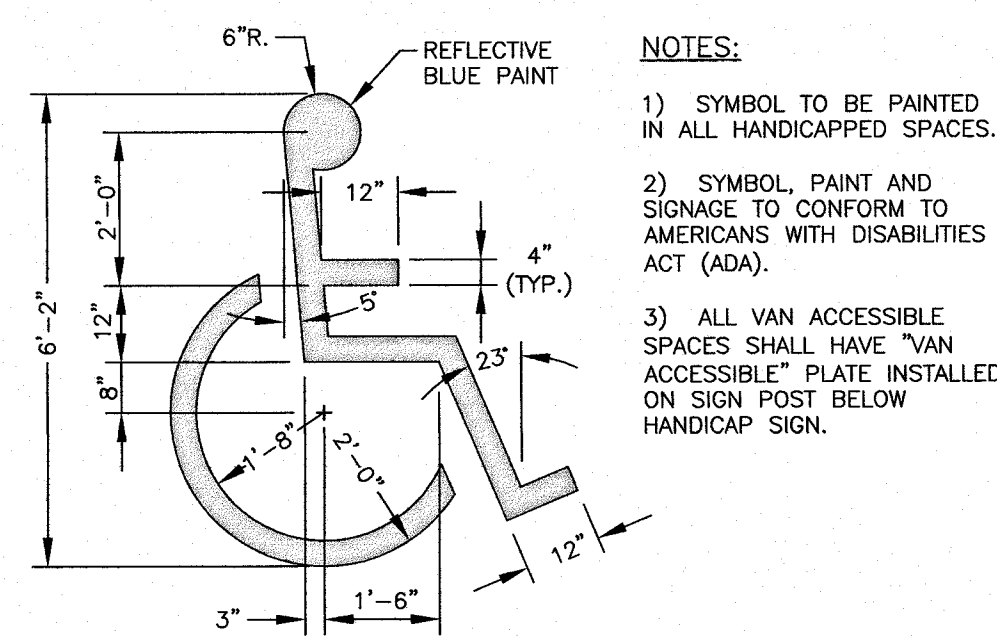

**NOTES:**

- 1) SYMBOL TO BE PAINTED IN ALL HANDICAPPED SPACES.
- 2) SYMBOL, PAINT AND SIGNAGE TO CONFORM TO AMERICANS WITH DISABILITIES ACT (ADA).
- 3) ALL VAN ACCESSIBLE SPACES SHALL HAVE "VAN ACCESSIBLE" PLATE INSTALLED ON SIGN POST BELOW HANDICAP SIGN.



R7-8a  
12" x 18"  
SIGN ON POST  
EACH SPACE SHALL HAVE THIS SIGN DISPLAYED PER ADA CODE

**SIGNAGE**

**G ADA SIGN & PAVEMENT MARKING**  
C4 NTS

**CONSTRUCTION NOTE:**  
EXISTING GRANITE CURB DISTURBED BY CONSTRUCTION SHALL BE REUSED AND ANY MISSING CURB SHALL BE REPLACED WITH NEW CURB MATCHING EXISTING CURB SIZE. NO CURB LESS THAN 3' IN LENGTH WILL BE ALLOWED.

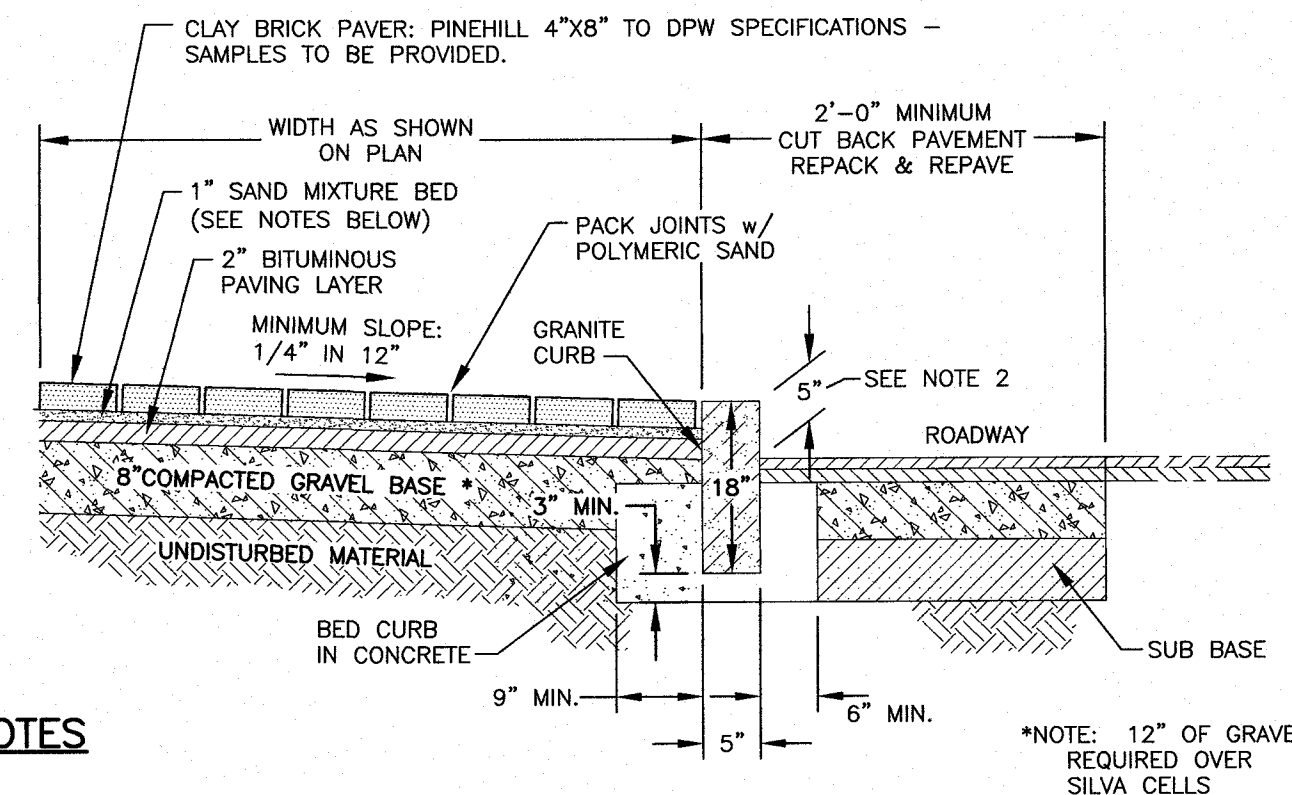

**BRICK PAVEMENT NOTES**

**SCOPE OF WORK:**

- 1) THE WORK SHALL CONSIST OF CONSTRUCTING/RECONSTRUCTING THE SUB-BASE AND CONSTRUCTING A NEW BRICK SIDEWALK AS DIRECTED IN THE FIELD BY THE ENGINEER.
- 2) REVEAL SHALL BE 5" (COORDINATE WITH PORTSMOUTH DPW).

**METHODS OF CONSTRUCTION:**

- A) ALL LABOR AND MATERIALS SHALL CONFORM TO THE STATE OF NEW HAMPSHIRE STANDARD SPECIFICATIONS FOR ROAD AND BRIDGE CONSTRUCTION, SECTION 608, AND CITY OF PORTSMOUTH SPECIFICATIONS FOR NEW BRICK SIDEWALK, SECTION 6.
- B) ALL BRICKS SHALL CONFORM TO THE REQUIREMENTS OF ASTM STANDARD SPECIFICATIONS FOR BUILDING BRICKS: CLASS SX, TYPE 1, APPLICATION PX. THE BRICKS SHALL BE NO. 1, WIRE CUT TYPE FOR PAVING, WITH A COMPRESSIVE STRENGTH OF NOT LESS THAN 6,000 POUNDS PER SQUARE INCH. THE BRICKS SHALL NOT BE CORED OR HAVE FROGS AND SHALL BE OF A STANDARD SIZE (2.25" X 3.625" X 7.625").
- C) EXCAVATION FOR SIDEWALKS SHALL BE AT A DEPTH OF 10 INCHES BELOW FINISH GRADE. IN AREAS NOT BUTTING CURBING OR BUILDINGS, THE EXCAVATION SHALL BE 6 INCHES WIDER THAN THE FINISHED SIDEWALK WIDTH. AT ALL DRIVE CROSSINGS, THE DEPTH OF EXCAVATION SHALL BE INCREASED ACCORDINGLY. THE CONTRACTOR SHALL PROVIDE NEAT AND SQUARE CUTTING OF EXISTING ASPHALT ROAD SURFACE AS NEEDED. ALL UNSUITABLE MATERIAL SHALL BE REMOVED AND DISPOSED OF OFF-SITE AT THE CONTRACTOR'S OWN EXPENSE.
- D) THE BASE MATERIAL SHALL CONSIST OF A MIXTURE OF STONES OR ROCK FRAGMENTS AND PARTICLES WITH 100% PASSING THE 3 INCH SIEVE, 95% TO 100% PASSING THE 2 INCH SIEVE, 55% TO 85% PASSING THE 1 INCH SIEVE, AND 27% TO 52% PASSING THE NO. 4 SIEVE. AT LEAST 50% OF THE MATERIALS RETAINED ON THE 1 INCH SIEVE SHALL HAVE A FRACTURED FACE. THE BASE MATERIAL SHALL BE THOROUGHLY COMPACTED TO THE DEPTH SPECIFIED OR DIRECTED. IN THE WAY OF ALL DRIVE CROSSINGS THE BASE WILL BE INCREASED TO A COMPACTED DEPTH OF 12 INCHES. GRAVEL REQUIREMENTS FOR RECONSTRUCTION WILL BE AS DIRECTED, BASED ON SITE CONDITIONS. THE WORK INCLUDES BACKING UP ANY AND ALL CURB BEING INSTALLED BY OTHERS ON BOTH SIDES.
- E) THE CLAY BRICK PAVERS SHALL BE LAID IN A 1 INCH BED OF A SAND MIXTURE COMPRISED OF: 3 PARTS SAND MIXED WITH 1 PART PORTLAND CEMENT.
- F) THE CONTRACTOR SHALL LAY THE BRICKS SO THAT APPROXIMATELY 5.2 BRICKS SHALL COVER ONE SQUARE FOOT.
- G) THE SIDEWALK SHALL PITCH TOWARDS THE STREET AS SHOWN ON THE GRADING PLAN.
- H) IN AREAS WHERE THE FRONT OF THE BRICK SIDEWALK IS NOT ADJACENT TO GRANITE CURBING, THE CONTRACTOR SHALL INSTALL EDGING TO HOLD THE BRICKS IN PLACE. SUCH EDGING SHALL BE INSTALLED PER THE MANUFACTURER'S RECOMMENDATIONS.
- I) THE CONTRACTOR SHALL SUBMIT A SAMPLE OF THE BRICKS FOR APPROVAL BY THE CITY BEFORE BRICKS ARE INSTALLED.

**H BRICK SIDEWALK w/ VERTICAL GRANITE CURB**  
C3 (STONE DUST BEDDING OVER BITUMINOUS PAVING) NTS

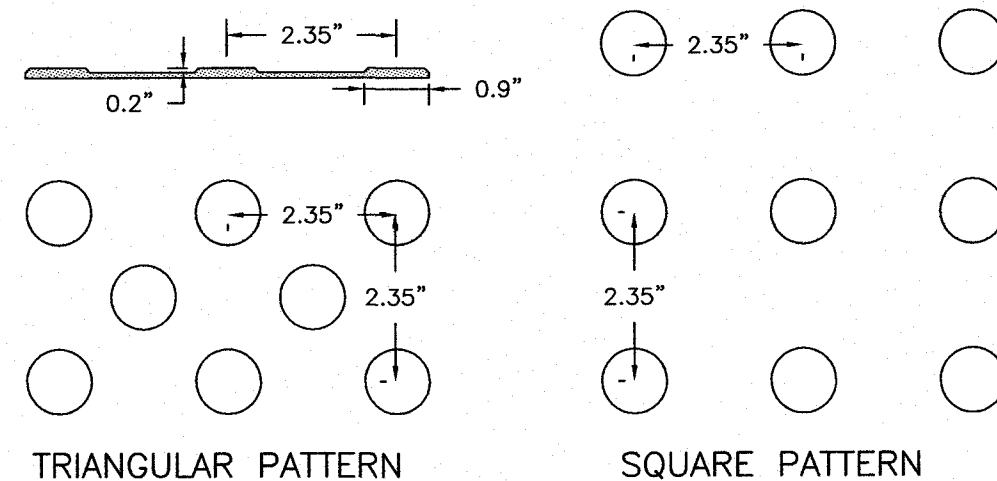

EITHER PATTERN IS ACCEPTABLE

- NOTE:**
1. CURB RAMPS MUST HAVE A DETECTABLE WARNING FEATURE EXTENDING THE FULL WIDTH OF THE RAMP, A HEIGHT OF NOMINAL 0.2", THE DETECTABLE SURFACE MUST CONSIST OF RAISED TRUNCATED SPACING OF NOMINAL 2.35". THE TEXTURE OF THE DETECTABLE WARNING FEATURE MUST CONTRAST VISUALLY WITH THE SURROUNDING SURFACES (LIGHT-ON-DARK OR DARK-ON-LIGHT).
  2. DETECTABLE WARNING SURFACE SHALL BE IRON PANEL TO FILL THE SPACE SHOWN ON THE SITE PLAN.

**I DETECTABLE WARNING SURFACE**  
C3 NTS

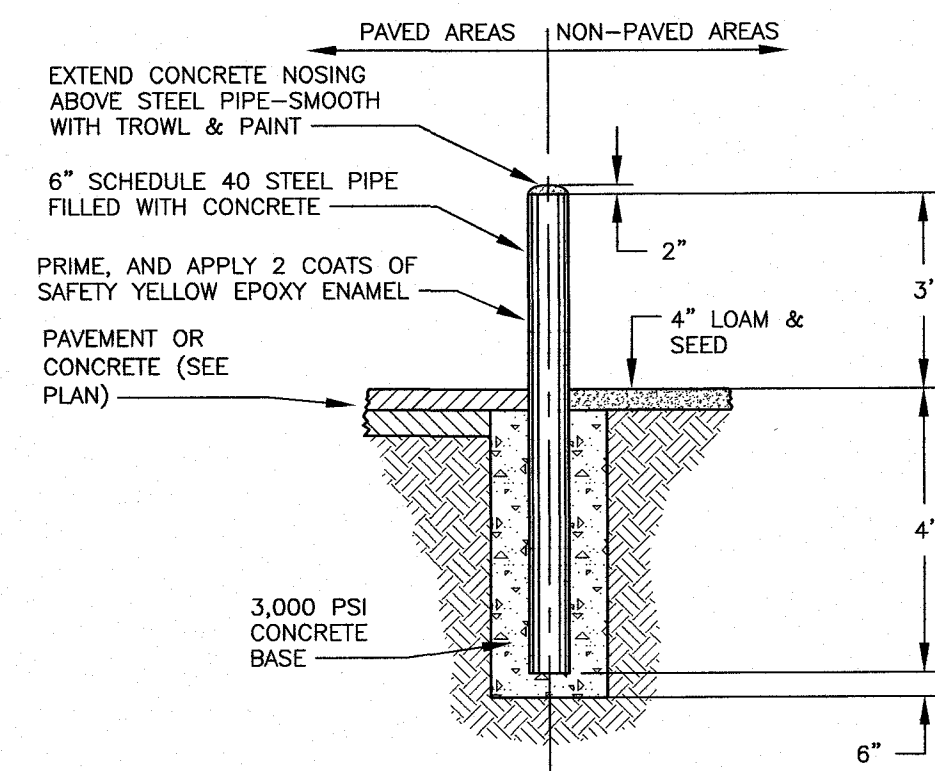

**J PIPE BOLLARD DETAIL**  
C4 NTS

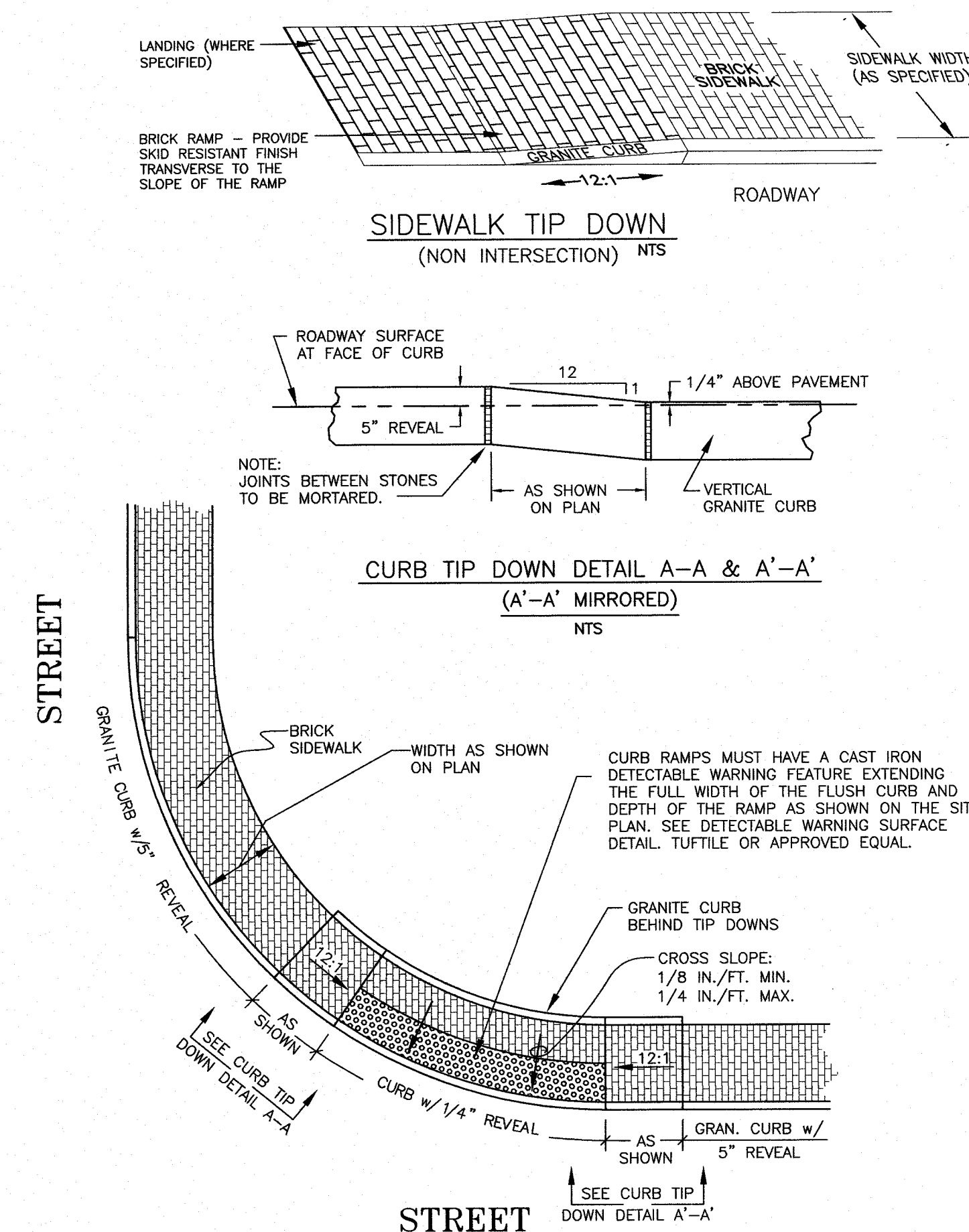

**K TYPICAL SIDEWALK TIP DOWNS**  
C3 NTS

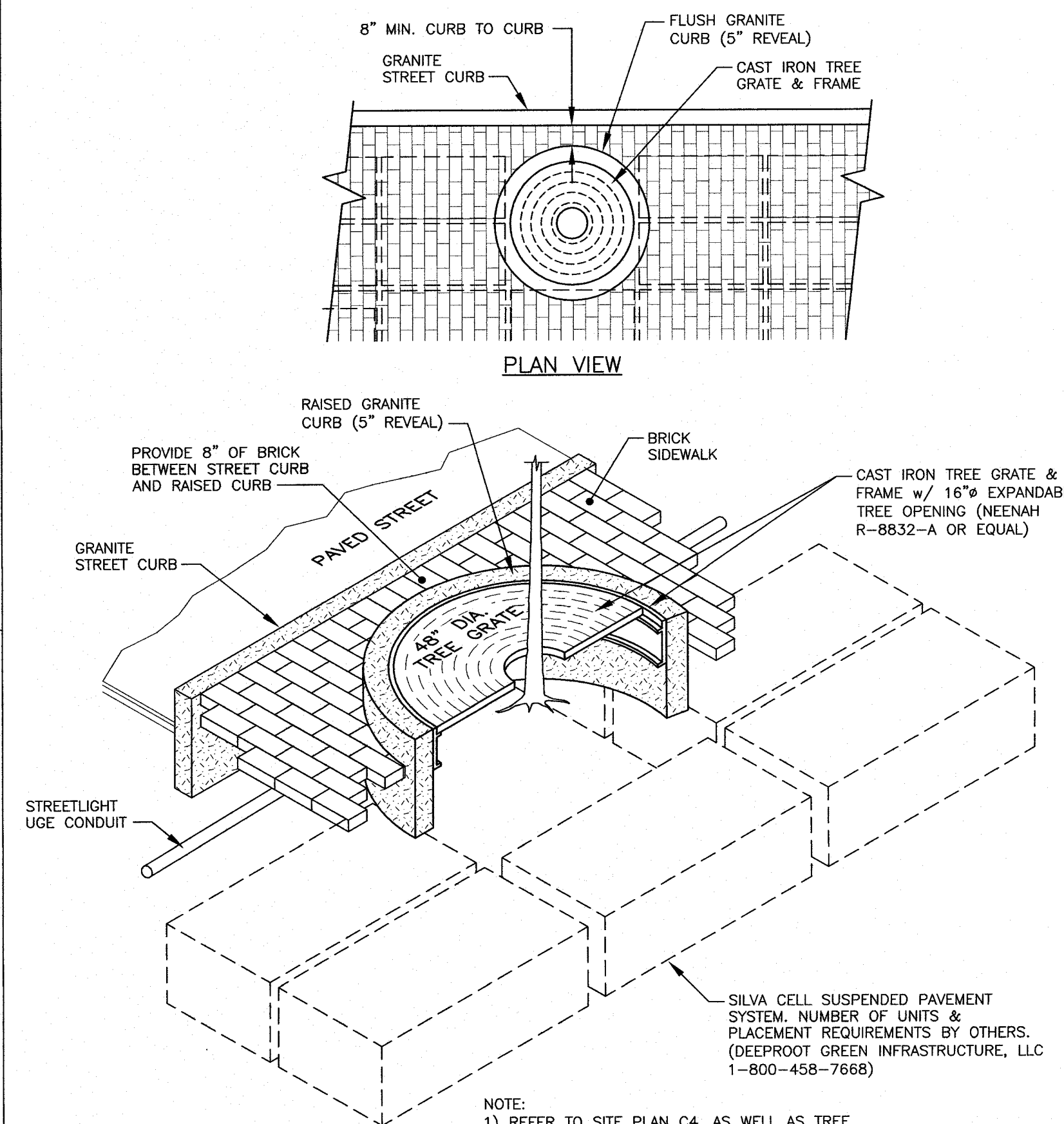

**L TREE WELL w/ GRANITE CURB**  
C3 5" DIA. OUTSIDE CURB DIMENSION NTS

NOTE:  
1) REFER TO SITE PLAN C4, AS WELL AS TREE PLANTING, GRANITE CURB & BRICK SIDEWALK DETAILS FOR FURTHER INFORMATION.

APPROVED BY THE PORTSMOUTH PLANNING BOARD

CHAIRMAN \_\_\_\_\_ DATE \_\_\_\_\_

**TAX MAP 125 LOT 2A**  
**46-64 MAPLEWOOD AVENUE**  
**PORTSMOUTH, N.H.**

3	DETAILS H & F	1/12/18
2	DETAILS E, H, I, J AND K	12/19/17
1	DETAILS F/C3, G/C4, I/C3, K/C3 & L/C3	10/17/17
0	ISSUED FOR COMMENT	6/19/17
NO.	DESCRIPTION	DATE

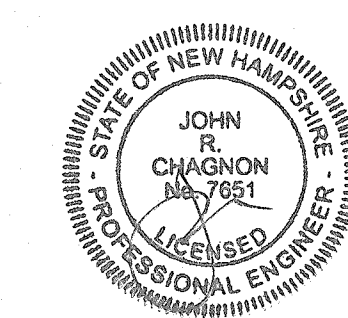

SCALE: AS NOTED JUNE 2017

DETAILS

D2



**AMBIT ENGINEERING, INC.**  
Civil Engineers & Land Surveyors

200 Griffin Road, Unit 3  
Portsmouth, N.H. 03801-7114  
Tel (603) 430-9282  
Fax (603) 436-2315

**NOTES:**

- THE CONTRACTOR SHALL NOTIFY DIG SAFE AT 1-888-DIG-SAFE (1-888-344-7233) AT LEAST 72 HOURS PRIOR TO COMMENCING ANY EXCAVATION ON PUBLIC OR PRIVATE PROPERTY.
- UNDERGROUND UTILITY LOCATIONS ARE BASED UPON BEST AVAILABLE EVIDENCE AND ARE NOT FIELD VERIFIED. LOCATING AND PROTECTING ANY ABOVEGROUND OR UNDERGROUND UTILITIES IS THE SOLE RESPONSIBILITY OF THE CONTRACTOR AND/OR THE OWNER. UTILITY CONFLICTS SHOULD BE REPORTED AT ONCE TO THE DESIGN ENGINEER.
- CONTRACTOR SHALL INSTALL AND MAINTAIN EROSION CONTROL MEASURES IN ACCORDANCE WITH THE "NEW HAMPSHIRE STORMWATER MANUAL, VOLUME 3, EROSION AND SEDIMENT CONTROLS DURING CONSTRUCTION. (NHDES DECEMBER 2008).

FLUSH GROUND MOUNTED HANDHOLE PROVIDED BY SITE ELECTRICAL CONTRACTOR. HANDHOLE SHALL BE NEMA 4 RAIN TIGHT. PVC CONSTRUCTION WITH GASKETED REMOVABLE COVER FASTENED WITH TAMPERPROOF SCREWS. 36" L X 24" W X 24" D AND OPEN BOTTOM

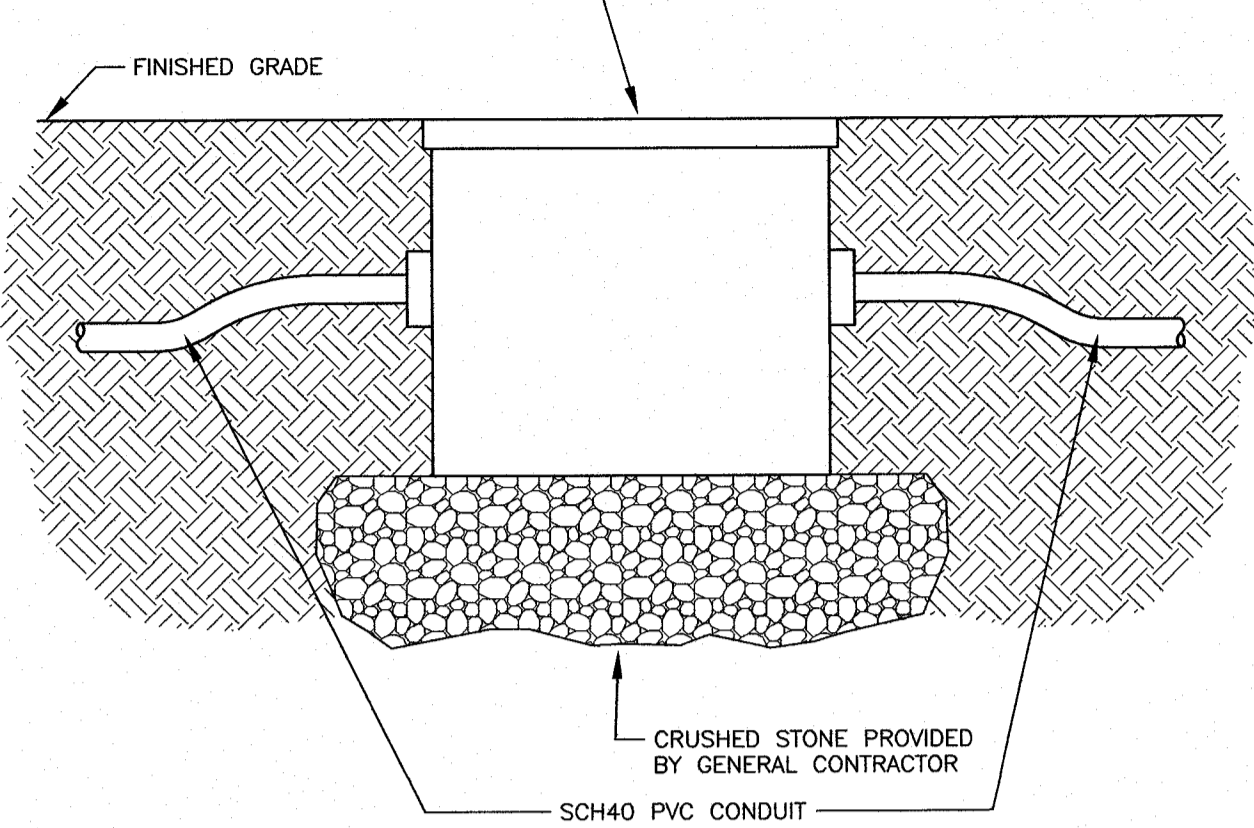

**M C5** TYPICAL SITE LIGHTING HANDHOLE  
NTS

CONSTRUCT BRICK OR CONCRETE SHELVES AND INVERT (SLOPE SHELVES TO DRAIN)

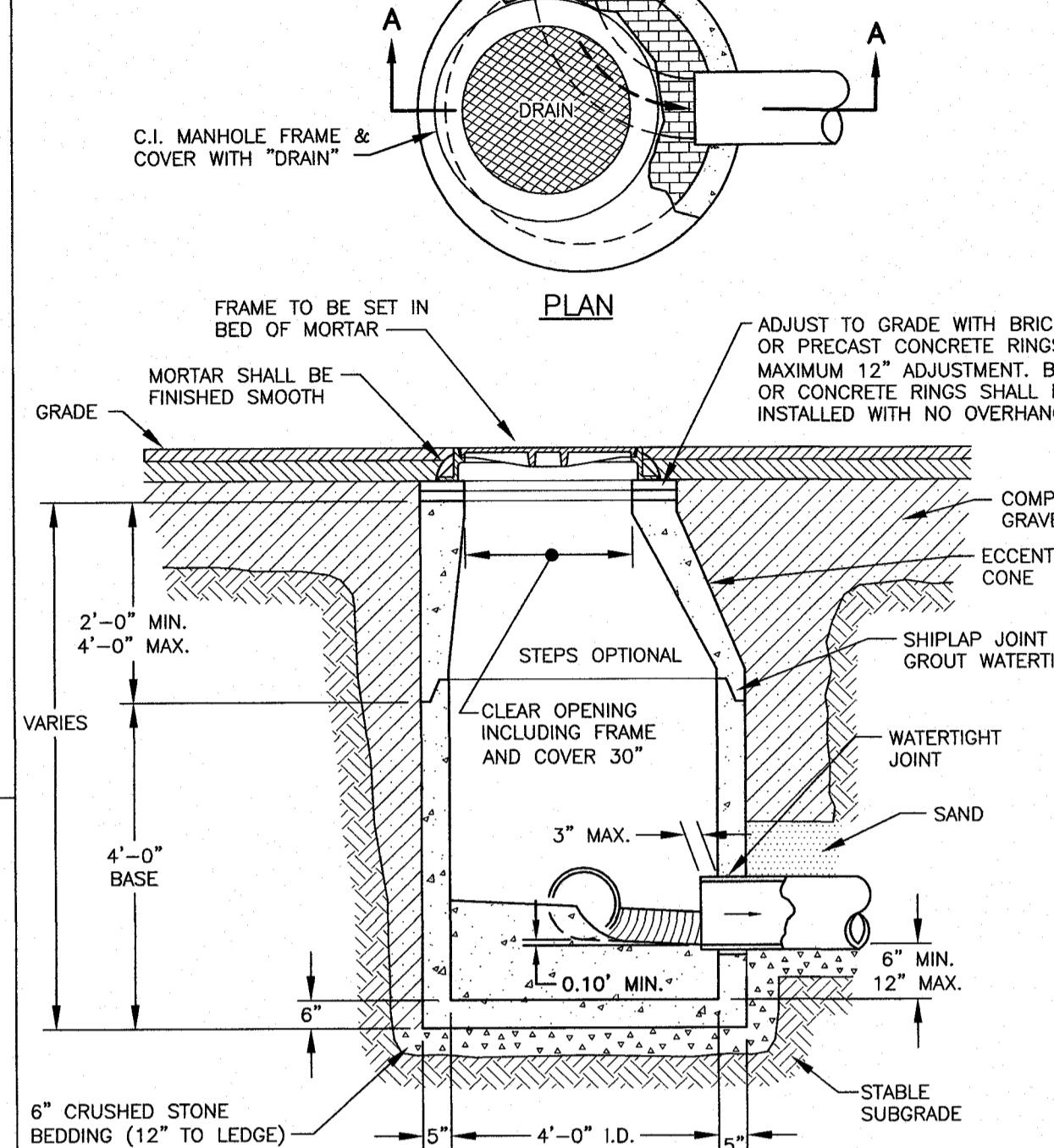

- NOTES:**
- CONCRETE SHALL BE 4,000 P.S.I. AFTER 28 DAYS.
  - CIRCUMFERENTIAL REINFORCEMENT SHALL BE 0.12 SQ. IN. PER LINEAR FT. IN ALL SECTIONS AND SHALL BE PLACED IN THE CENTER THIRD OF THE WALL.
  - THE TONGUE OR THE GROOVE OF THE JOINT SHALL CONTAIN ONE LINE OF CIRCUMFERENTIAL REINFORCEMENT EQUAL TO 0.12 SQ. IN. PER LINEAR FT.
  - EACH CASTING TO HAVE LIFTING HOLES CAST IN.

**P C6** DRAIN MANHOLE DETAIL  
NTS

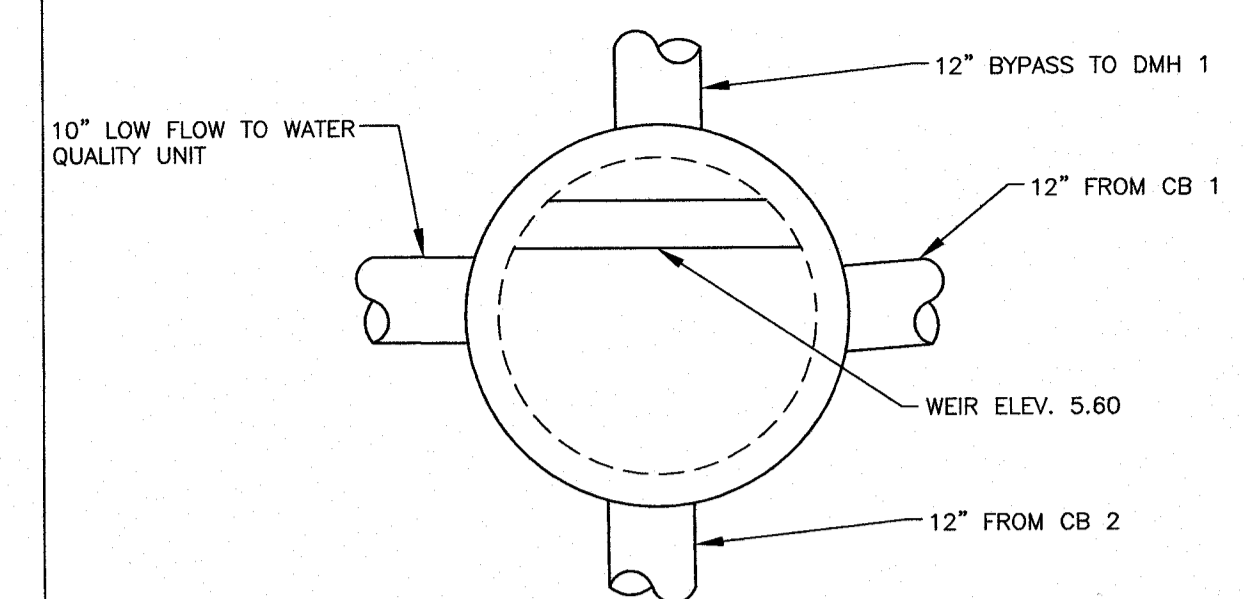

**R1 C6** OCS #1 WEIR DETAIL  
CONCRETE WEIR INSIDE CONCRETE STRUCTURE  
NTS

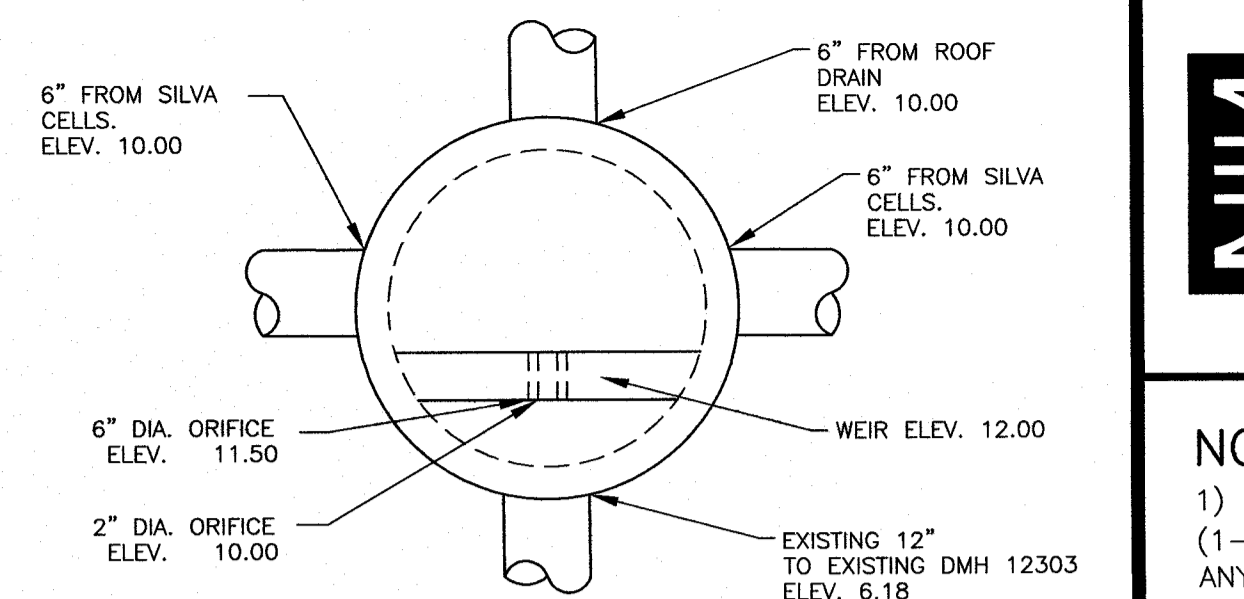

**R2 C6** OCS #2 WEIR DETAIL  
CONCRETE WEIR INSIDE CONCRETE STRUCTURE  
NTS

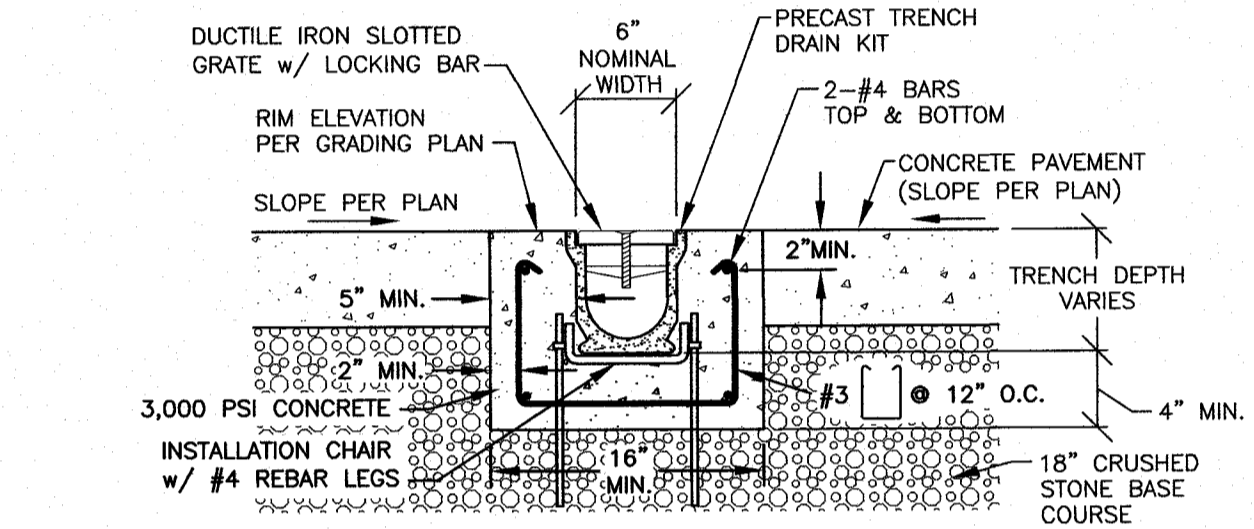

**N C4 C6** GARAGE EVAPORATIVE TRENCH DRAIN  
NTS

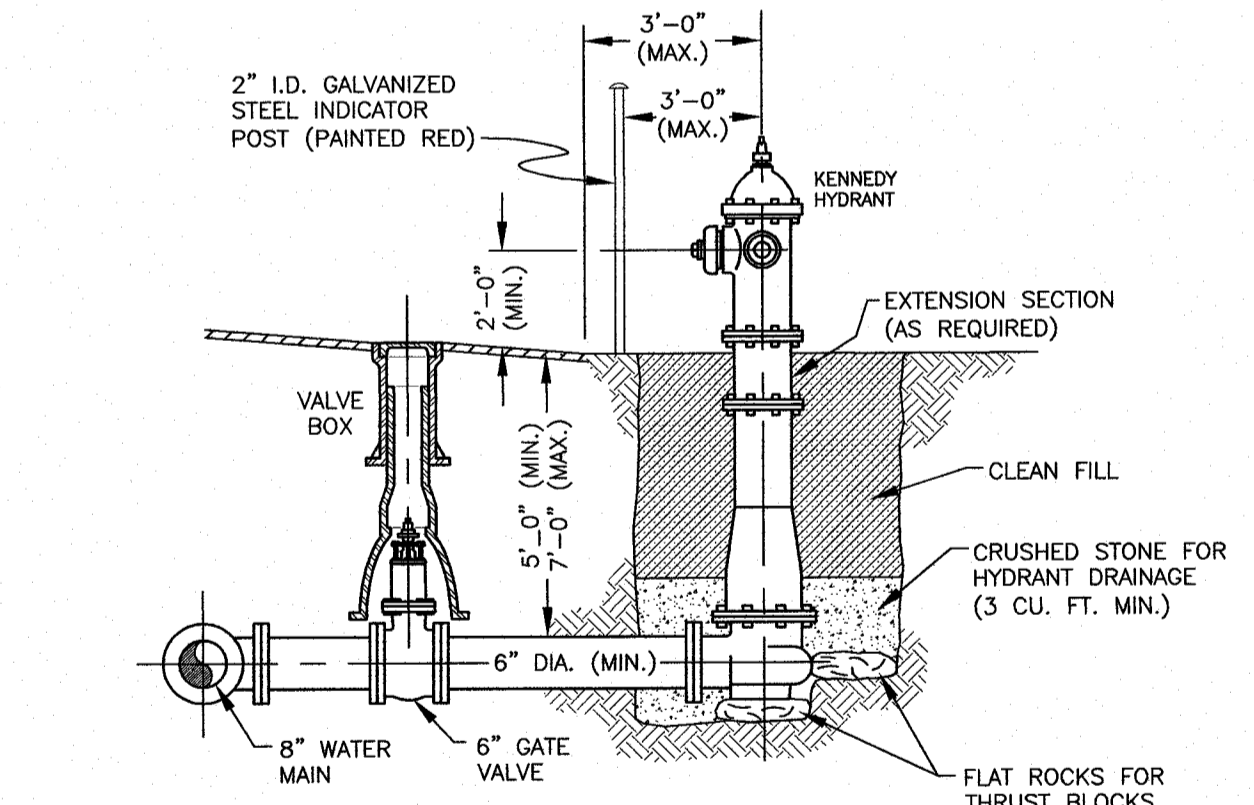
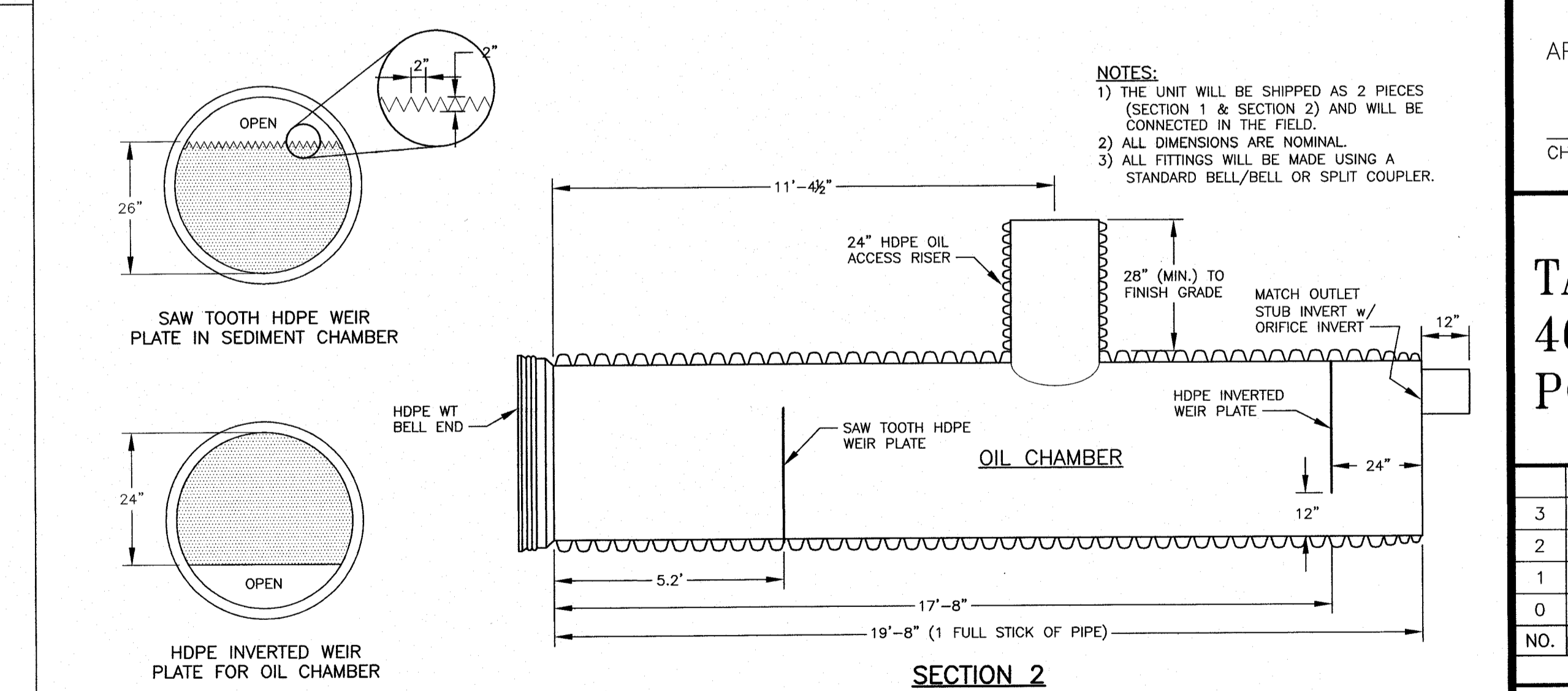
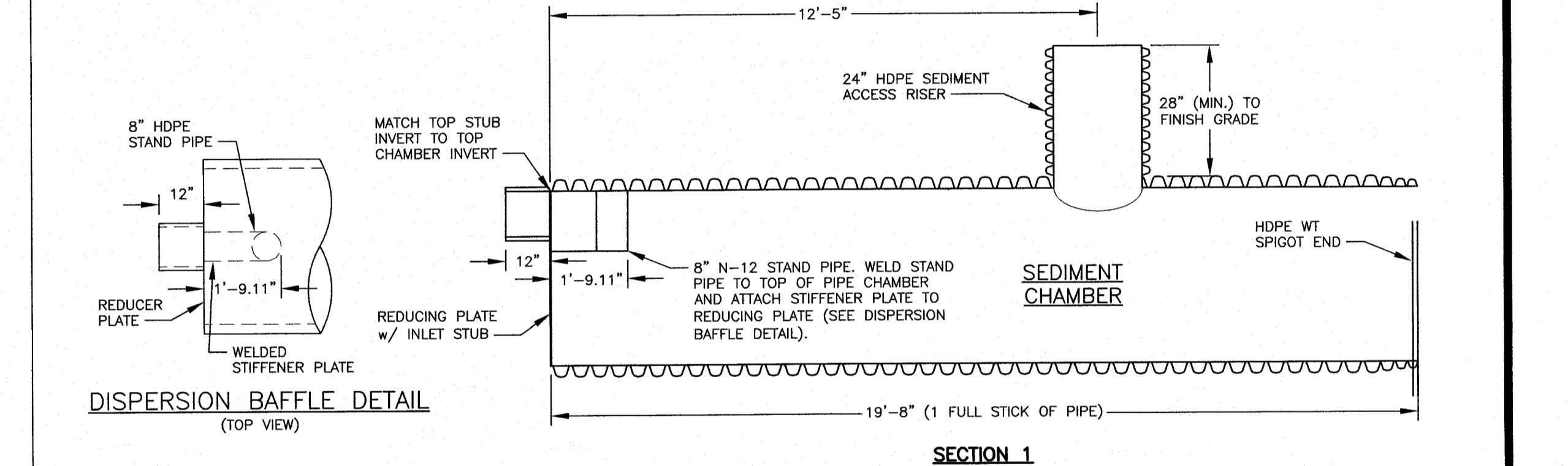

- NOTES:**
- HYDRANTS SHALL BE INSTALLED A MAXIMUM DISTANCE OF 3 FEET CURB LINE TO OPERATING NUT.
  - THE PUMPER OUTLET NOZZLE SHALL FACE THE STREET.
  - CENTERLINE OF NOZZLES SHALL BE A MINIMUM OF 2 FEET ABOVE FINISHED GRADE OF STREET.
  - AREA AROUND HYDRANT SHALL BE GRADED TO ALLOW ANY SURFACE WATER TO DRAIN AWAY FROM HYDRANT.
  - HYDRANT SHALL BE FIRMLY SUPPORTED ALL AROUND THE STANDPIPE.
  - EARTH FILL SHALL BE TAMPED TO GIVE FIRM SUPPORT TO THE HYDRANT BARREL.
  - A GATE VALVE SHALL BE INSTALLED BETWEEN THE HYDRANT AND THE MAIN ON THE LATERAL.
  - HYDRANT LATERALS SHALL BE 6" INSIDE DIAMETER (MINIMUM).
  - HYDRANT LATERALS SHALL BE CONNECTED TO WATER MAINS 8 INCHES IN DIAMETER OR LARGER.
  - ALL JOINTS AT HYDRANT CONNECTION SHALL BE RESTRAINED MECHANICAL JOINTS.
  - INSTALLATION OF HYDRANTS IN AREAS OF HEAVY VEGETATIVE GROWTH SHALL HAVE A 10 FOOT RADIUS CLEAR AREA ALL AROUND THE OPERATING NUT OF THE HYDRANT.
  - THERE SHALL ALSO BE AN INDICATOR POST FABRICATED FROM 2 INCH INSIDE DIAMETER GALVANIZED STEEL PIPE, 7 FEET ABOVE FINISHED GRADE, AND SET 2 FEET BELOW GRADE IN CLASS "A" CONCRETE CONCRETE 6 INCHES ALL AROUND POST. THIS POST SHALL BE COATED WITH ZINC CHROMATE PRIMER AND PAINTED WITH HIGH VISIBLE RED. THE INDICATOR POST SHALL BE NO CLOSER THAN 3 FEET FROM THE OPERATING NUT, AND SET ON THE SIDE OF THE HYDRANT FACING ONCOMING TRAFFIC. TOP OF POST SHALL BE THREADED AND CAPPED.
  - INSTALLATION OF HYDRANTS IN HEAVY GROWTH AREAS SHALL HAVE GATE BOXES RAISED 6 INCHES ABOVE GRADE AND SHALL BE PAINTED ORANGE FOR HIGH VISIBILITY.

**O C5** FIRE HYDRANT INSTALLATION DETAIL  
PORTSMOUTH  
NTS

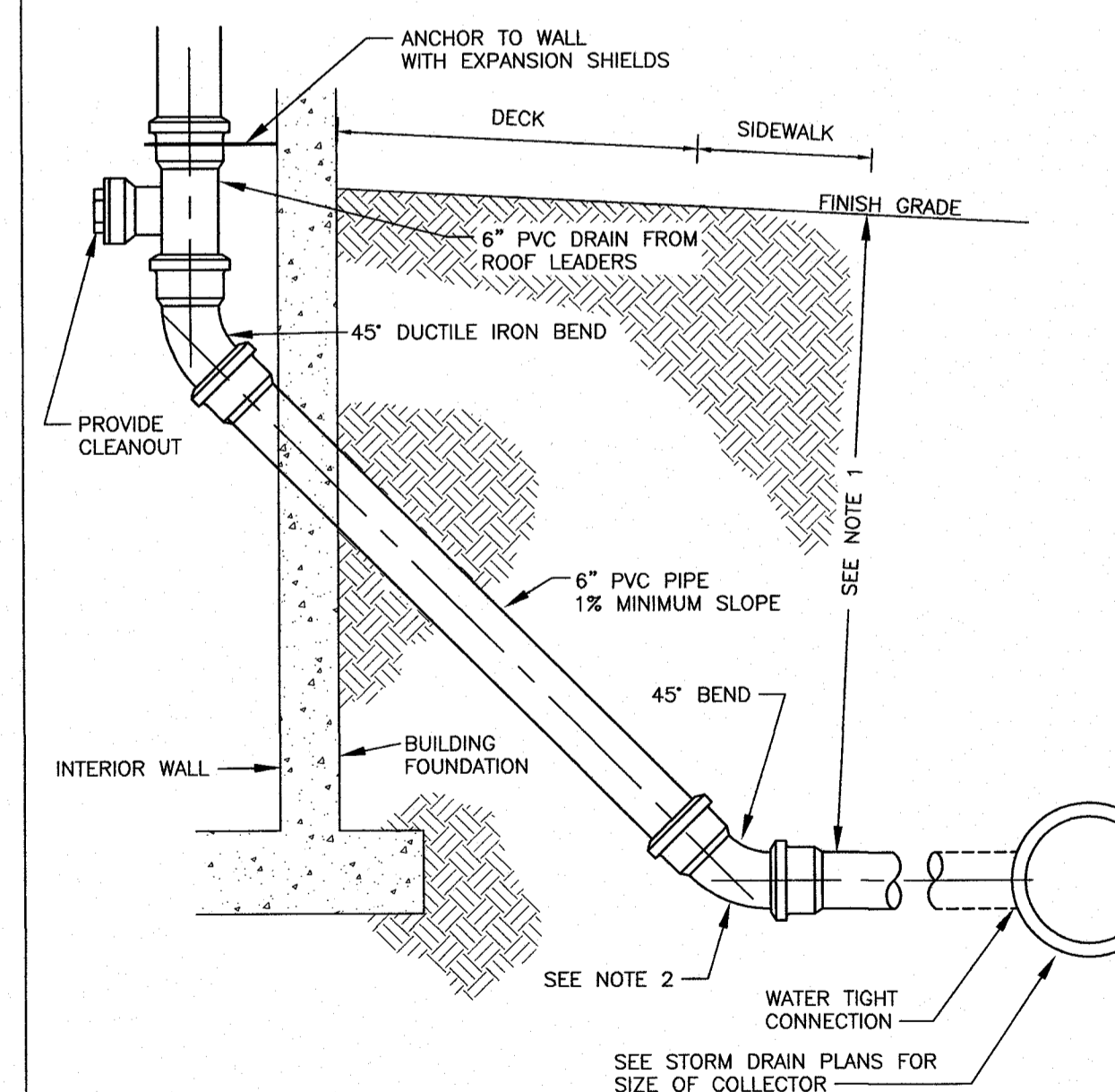

- NOTES:**
- FOR ALL DEPTHS OF COVER LESS THAN 2 FEET, PIPE MUST BE SCHEDULE 40 PVC. FOR DEPTHS OF COVER GREATER THAN 2 FEET, FLEXIBLE PIPE MAY BE USED.
  - A WATER TIGHT CONNECTION SHALL BE MAINTAINED WITH ANY TRANSITION FROM SCHEDULE 40 PVC PIPE TO ANY OTHER PIPE TYPE.
  - THE DOWNSPOUT COLLECTOR DRAIN SHALL BE INSTALLED BEFORE THE DOWNSPOUTS ARE INSTALLED ON THE BUILDING. SITE WORK CONTRACTOR SHALL BE RESPONSIBLE FOR ALL WORK TO AND INCLUDING THE FOUNDATION PENETRATION. BUILDING CONTRACTOR SHALL BE RESPONSIBLE FOR THE INTERIOR CONNECTION.

**Q C6** ROOF DRAIN DETAIL  
NTS

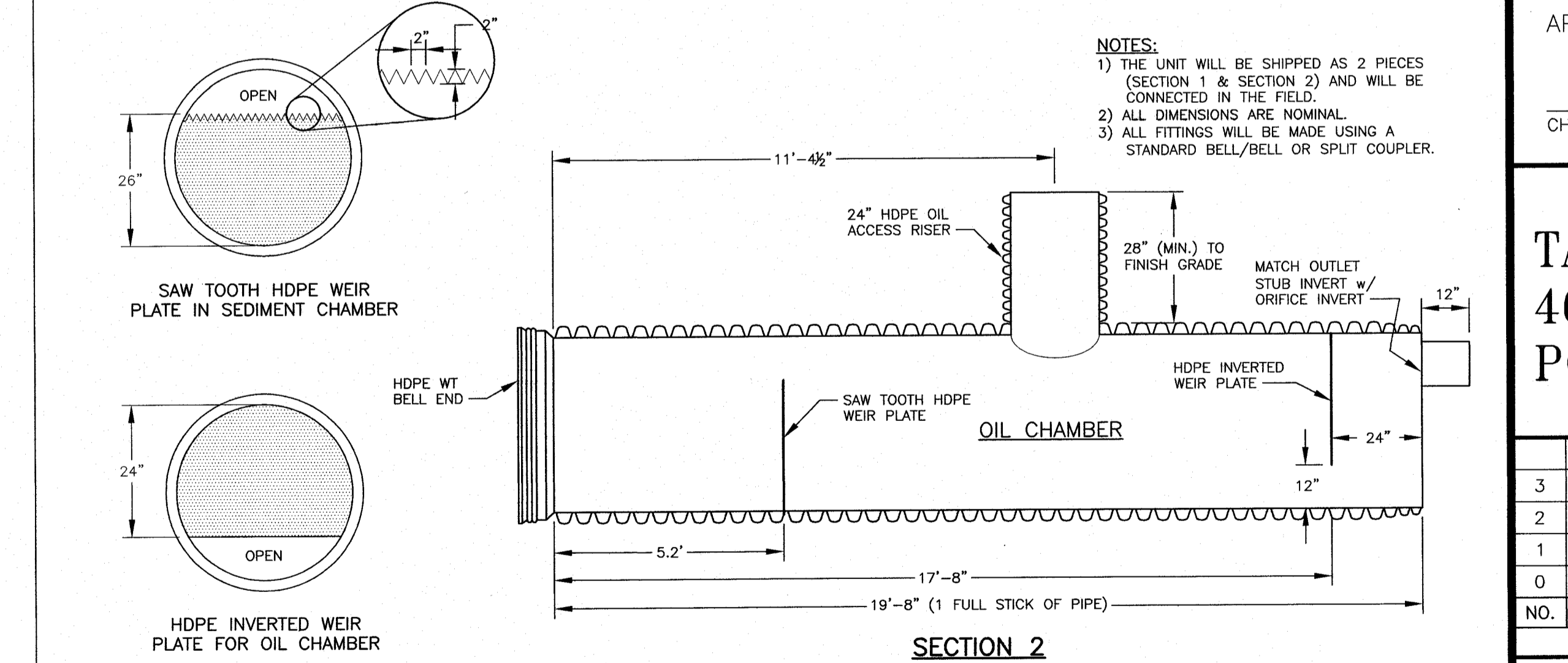

**S C6** HANCOR 3640WQA12 STORMWATER WATER QUALITY UNIT  
FOLLOW MANUFACTURER'S RECOMMENDED INSPECTION/MAINTENANCE GUIDELINES  
NTS

APPROVED BY THE PORTSMOUTH PLANNING BOARD

CHAIRMAN \_\_\_\_\_ DATE \_\_\_\_\_

**TAX MAP 125 LOT 2A**  
**46-64 MAPLEWOOD AVENUE**  
**PORTSMOUTH, N.H.**

NO.	DESCRIPTION	DATE
3	DETAIL M	1/12/18
2	DETAILS M, N, O, P, R1 & R2	12/19/17
1	DETAIL M/C6, P/C5 & Q/C6	10/17/17
0	ISSUED FOR COMMENT	6/19/17

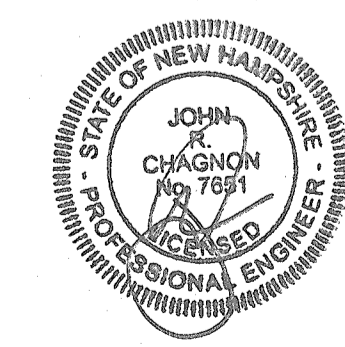

SCALE: AS NOTED  
JUNE 2017

DETAILS  
**D3**



**TRENCH NOTES:**

A) **TRENCH BACKFILL:**  
 - IN PAVED AREAS, SUITABLE MATERIAL FOR TRENCH BACKFILL SHALL BE THE NATURAL MATERIAL EXCAVATED DURING CONSTRUCTION, BUT SHALL EXCLUDE DEBRIS, PIECES OF PAVEMENT, ORGANIC MATTER, TOP SOIL, ALL WET OR SOFT MUCK, PEAT OR CLAY, ALL EXCAVATED LEDGE MATERIAL, AND ALL ROCKS OVER SIX INCHES IN LARGEST DIMENSION, OR ANY MATERIALS DEEMED TO BE UNACCEPTABLE BY THE ENGINEER.  
 - IN CROSS-COUNTRY CONSTRUCTION, SUITABLE MATERIAL SHALL BE AS DESCRIBED ABOVE, EXCEPT THAT THE ENGINEER MAY PERMIT THE USE OF TOP SOIL, LOAM, MUCK OR PEAT, IF HE IS SATISFIED THAT THE COMPLETED CONSTRUCTION WILL BE ENTIRELY STABLE.

B) "W" = MAXIMUM ALLOWABLE TRENCH WIDTH TO A PLANE 12 INCHES ABOVE THE PIPE. FOR PIPES 15 INCHES NOMINAL DIAMETER OR LESS, W SHALL BE NO MORE THAN 36 INCHES. FOR PIPES GREATER THAN 15 INCHES NOMINAL DIAMETER, W SHALL BE 24 INCHES PLUS PIPE O.D..

C) **TRENCH SHEETING:**  
 IF REQUIRED, WHERE SHEETING IS PLACED ALONGSIDE THE PIPE AND EXTENDS BELOW SPRING LINE, IT SHALL BE CUT OFF AND LEFT IN PLACE TO AN ELEVATION NOT LESS THAN 1 FOOT ABOVE THE TOP OF THE PIPE. WHERE SHEETING IS ORDERED BY THE ENGINEER TO BE LEFT IN PLACE, IT SHALL BE CUT OFF AT LEAST 3 FEET BELOW FINISHED GRADE, BUT NOT LESS THAN 1 FOOT ABOVE THE TOP OF THE PIPE.

D) **MINIMUM PIPE COVER FOR UTILITY MAINS (UNLESS GOVERNED BY OTHER CODES):**  
 6' MINIMUM FOR SEWER (IN PAVEMENT)  
 4' MINIMUM FOR SEWER (CROSS COUNTRY)  
 3' MINIMUM FOR STORMWATER DRAINS  
 5' MINIMUM FOR WATER MAINS

E) ALL PAVEMENT CUTS SHALL BE REPAIRED BY THE INFRARED HEAT METHOD.

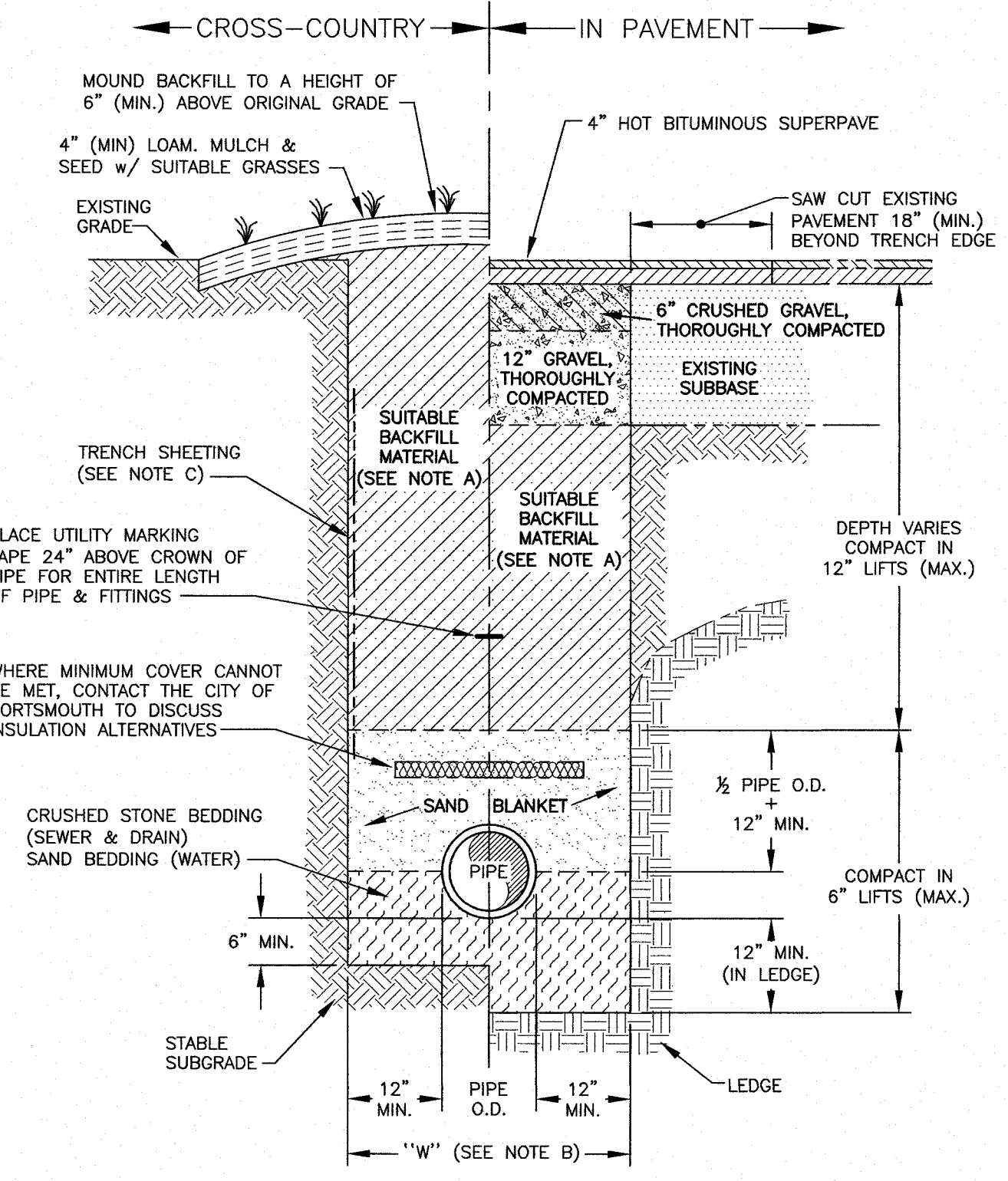

**T** TYPICAL PIPE TRENCH  
 C5 NTS

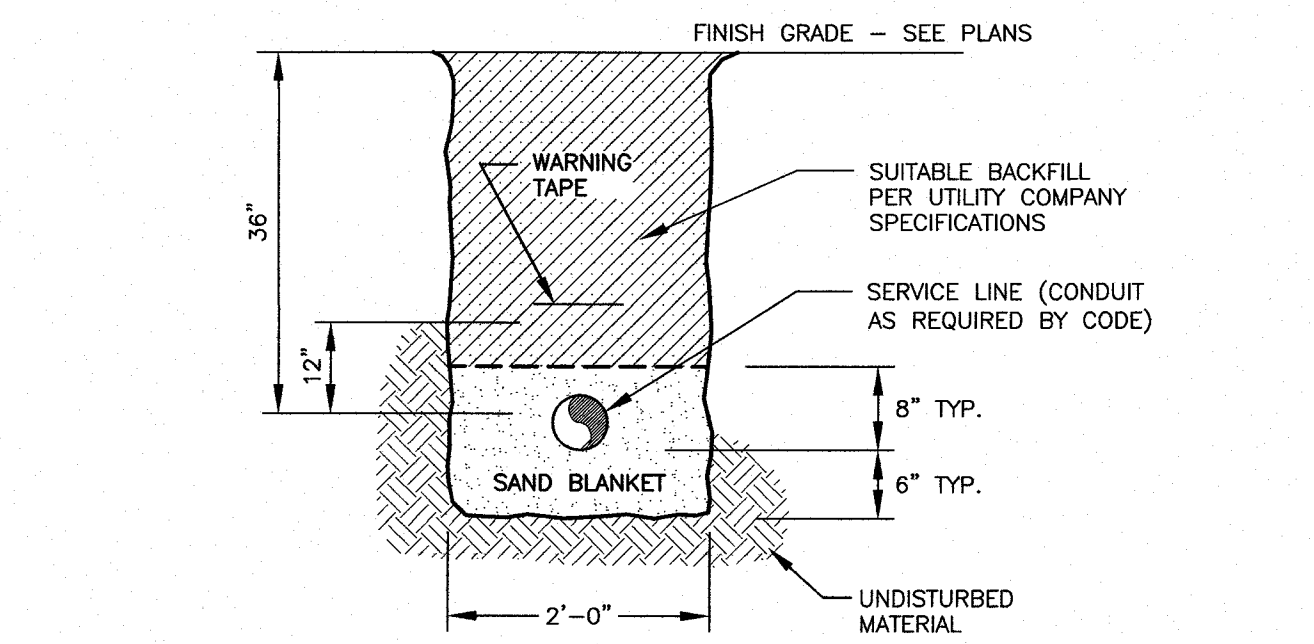

**NOTES:**

1. ALL CONDUIT TO BE U.L. LISTED, SCHED. 80 UNDER ALL TRAVEL WAYS AND ON PUBLIC PROPERTY & SCHED. 40 FOR THE REMAINDER.
2. NORMAL CONDUIT SIZES FOR PSNH ARE 3 INCH FOR SINGLE PHASE PRIMARY AND SECONDARY VOLTAGE CABLES, 4 INCH FOR THREE PHASE SECONDARY, AND 5 INCH FOR THREE PHASE PRIMARY. CONFIRM CONDUIT SIZE & TYPE WITH UTILITY COMPANY PRIOR TO INSTALLATION.
3. ALL WORK TO CONFORM TO THE NATIONAL ELECTRICAL CODE (LATEST REVISION).
4. INSTALL A 200# PULL ROPE FOR EACH CONDUIT

**U** ELECTRIC SERVICE TRENCH  
 C6 NTS

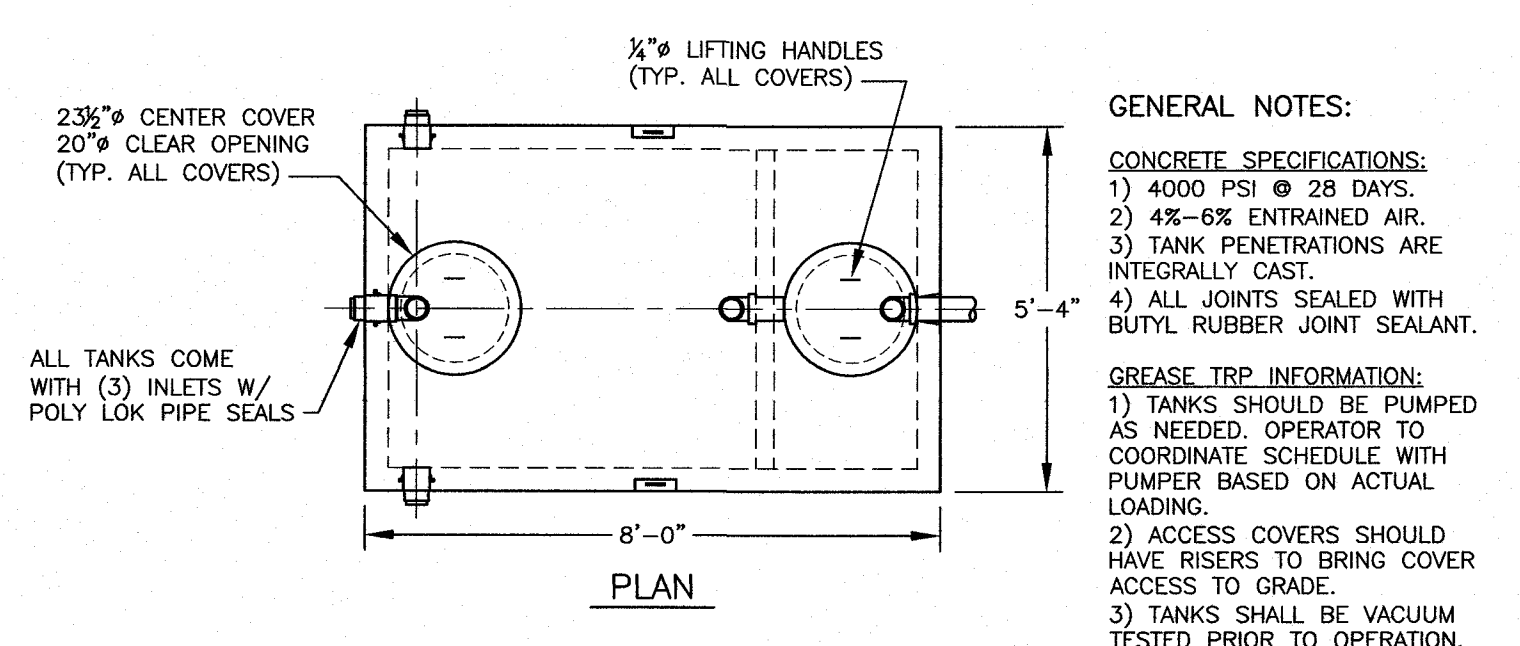

**GENERAL NOTES:**

**CONCRETE SPECIFICATIONS:**

- 1) 4000 PSI @ 28 DAYS.
- 2) 4%-6% ENTRAINED AIR.
- 3) TANK PENETRATIONS ARE INTEGRALLY CAST.
- 4) ALL JOINTS SEALED WITH BUTYL RUBBER JOINT SEALANT.

**GREASE TRP INFORMATION:**

- 1) TANKS SHOULD BE PUMPED AS NEEDED. OPERATOR TO COORDINATE SCHEDULE WITH PUMPER BASED ON ACTUAL LOADINGS.
- 2) ACCESS COVERS SHOULD HAVE RISERS TO BRING COVER ACCESS TO GRADE.
- 3) TANKS SHALL BE VACUUM TESTED PRIOR TO OPERATION.

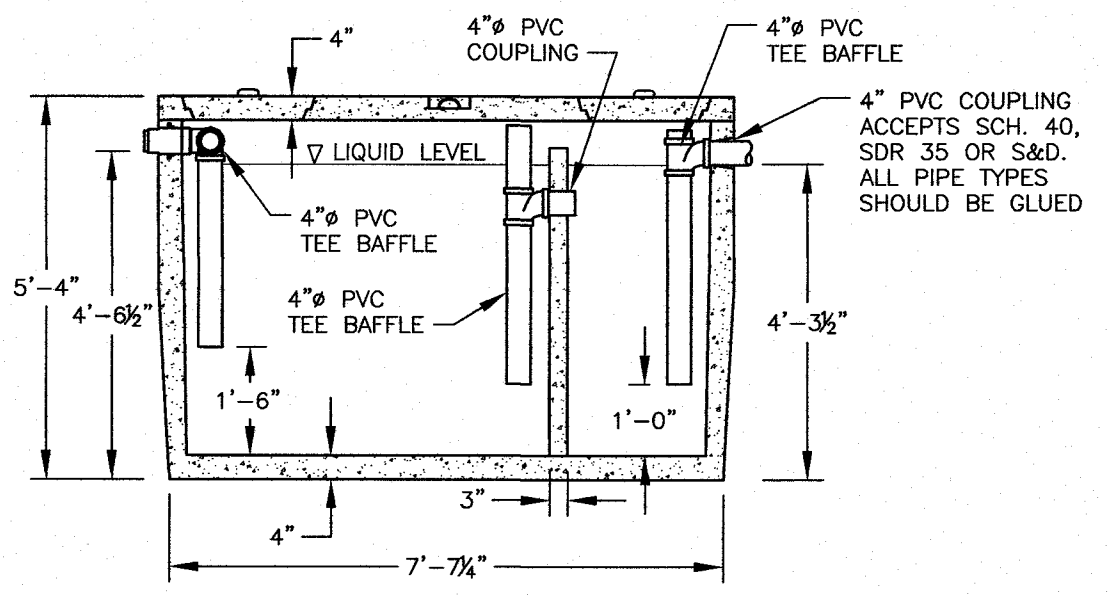

**V** 1000 GALLON 2 COMPARTMENT GREASE TRAP  
 C5 AMERICAN CONCRETE INDUSTRIES  
 9,200 Lbs TEM # 8827  
 NTS

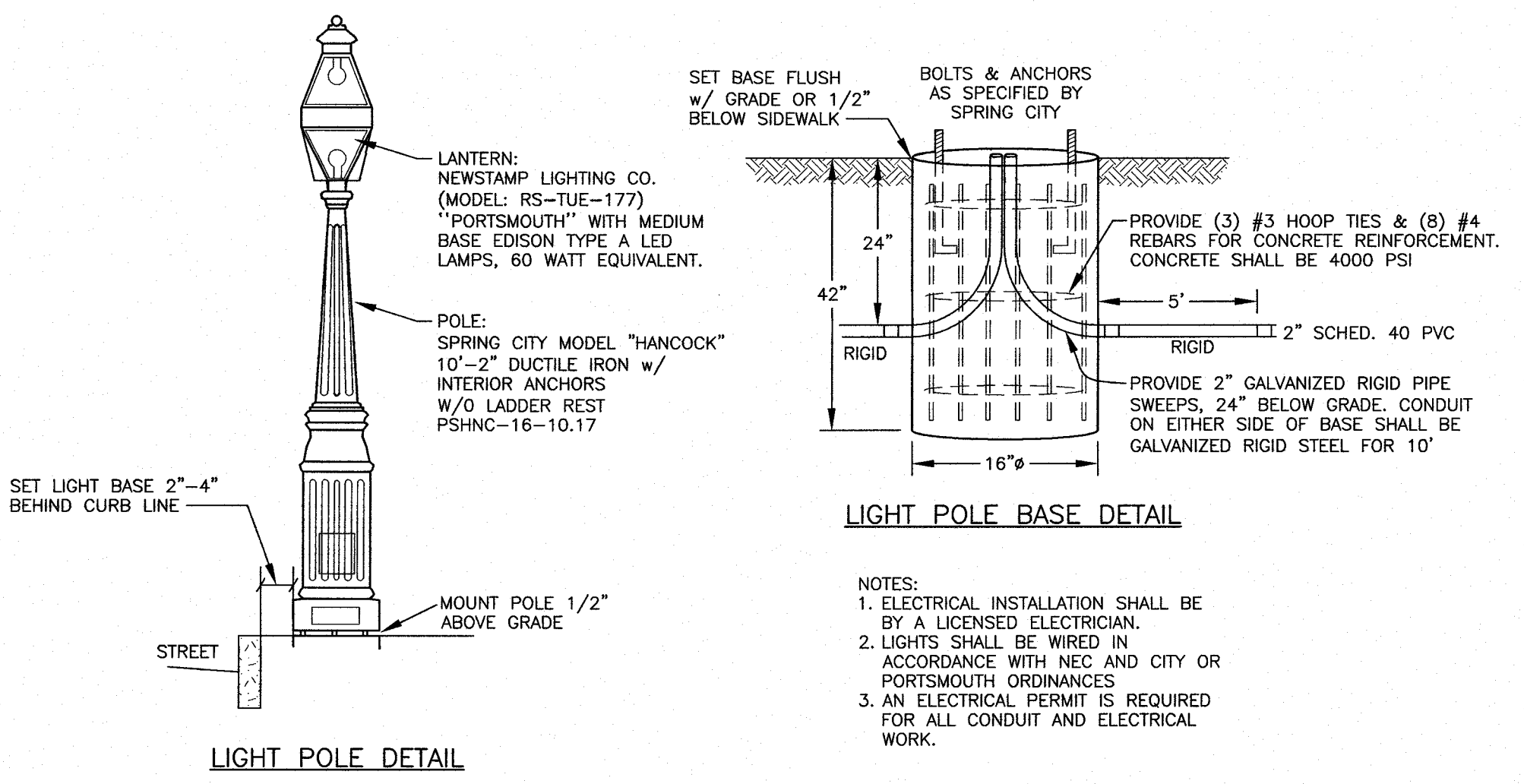

**W** LIGHT POLE & BASE DETAILS  
 C5 CITY STANDARD  
 NTS

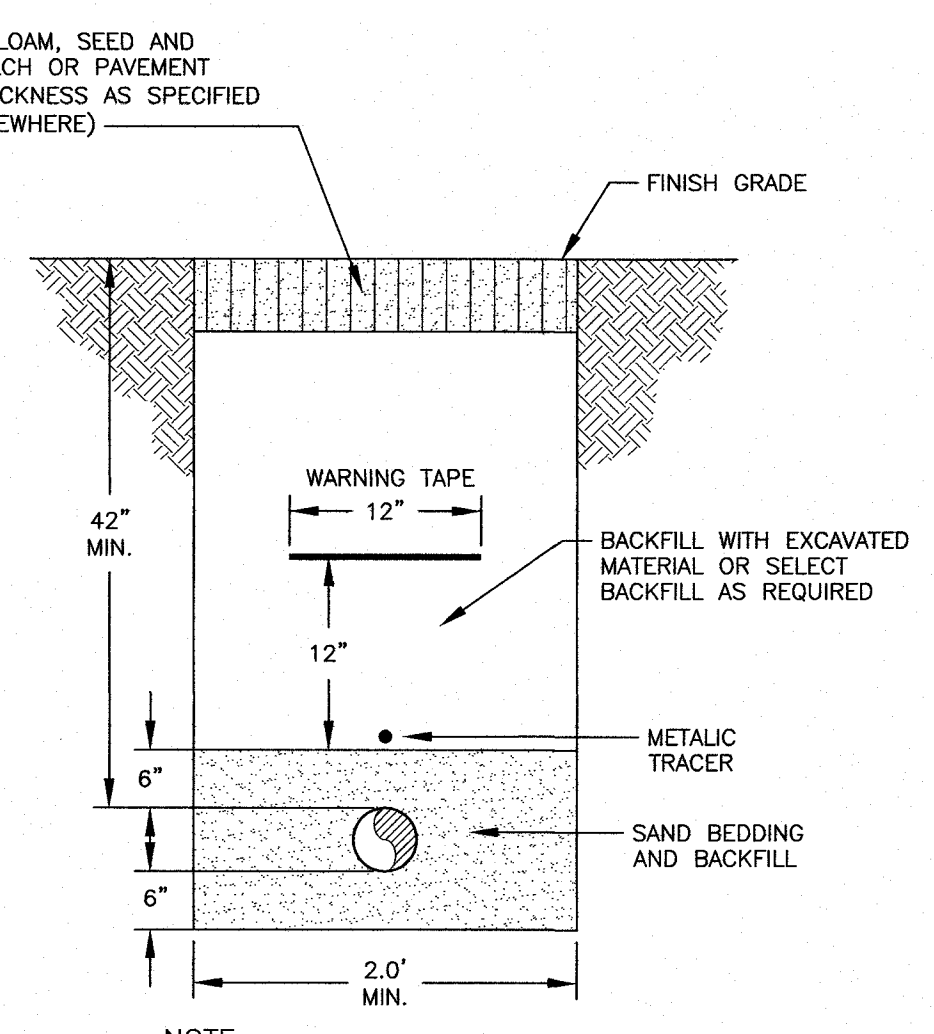

**NOTE:**

- 1) COORDINATE WITH GAS COMPANY REGARDING CONSTRUCTION RESPONSIBILITIES. (TRENCH AND BACKFILL/INSTALLATION)

**X** GAS SERVICE TRENCH  
 C5 NTS

**INSPECTION & MAINTENANCE PLAN**

The following inspection and maintenance program is necessary to keep the stormwater management system functioning properly. These measures will also help minimize potential environmental impacts. By following the enclosed procedures, the Owner will be able to maintain the functional design of the stormwater management system and maximize its ability to remove sediment and other contaminants from site generated stormwater runoff. By installing and maintaining the drainage as shown on the approved site plan, the Owner will be able to maximize the system's ability to control the volume of runoff and remove sediment from site generated stormwater runoff.

**Annual Report**

The Owner shall prepare an annual Inspection & Maintenance Report. The report shall include a summary of the system's maintenance and repair by transmission of the Inspection & Maintenance Log and other information as required. A copy of the report shall be delivered annually to the City of Portsmouth Building Inspector, if required.

**Inspection & Maintenance Checklist/Log**

The Inspection & Maintenance Checklist and a Stormwater Management System Inspection & Maintenance Log shall be included in the annual report.

**Inspection and Maintenance Requirements**

The following summarizes the inspection and maintenance requirements for the various BMP's that may be found on this project. In general, during construction and until the threat of erosion is minimal, rain events of 0.25" or more shall trigger close inspections of all related sediment and erosion control measures. It is only after construction is complete and the site is stable (safe from erosion) that larger rain events will trigger inspections (see attached Inspection & Maintenance Form).

- 1. Seeded areas:** After each rain event of 0.5" or more during a 24 hour period, inspect newly seeded areas for signs of disturbance, such as erosion or lost mulch. If damaged areas are discovered, immediately repair the damage. Repairs may include adding new topsoil, lime, seed, fertilizer and mulch, or may simply require the addition of more mulch. If mulch is constantly being blown away or washed away, then it shall be anchored with jute mesh. Continue inspections until grass growth is permanently established and threats of erosion have ceased.
- 2. Other Plantings:** Other planting and landscaping (trees, shrubs,) shall be monitored bi-monthly during the first year to insure viability and vigorous growth. Replace dead or dying vegetation with new stock and make adjustments to the conditions that caused the dead or dying vegetation. During dryer times of the year, provide weekly watering or irrigation during the establishment period of the first year. Make the necessary adjustments to insure long-term health of the vegetated covers, i.e. provide more permanent mulch or compost or other means of protection.
- 3. Storm Drain, Trench Drain Inlets/Outlets:** Monitor drain inlets and outlet aprons for excessive accumulation of sediments. Remove sediments as required to maintain flows to the infiltration (Silva Cell) area.
- 1. Stabilized Construction Entrance:** Monitor for signs of excessive clogging and tracking of mud onto the paved roadway. If necessary, replace the entire structure with new, clean stone, and remove tracked sediments from road surface.
- 2. Dust Control:** Monitor fugitive dust and if evident, apply water to graveled surfaces or mulch and water to exposed, droughty soils.
- 3. Hancor Water Quality Unit:** Remove sediment the more frequent of every six months or when sediment has reached 25% of the diameter of the structure. Furthermore, the system may need cleaning in the event a spill of foreign substance enters the unit.
- 4. Parking Lot maintenance:** Sweep Parking areas twice per year to remove sediments.

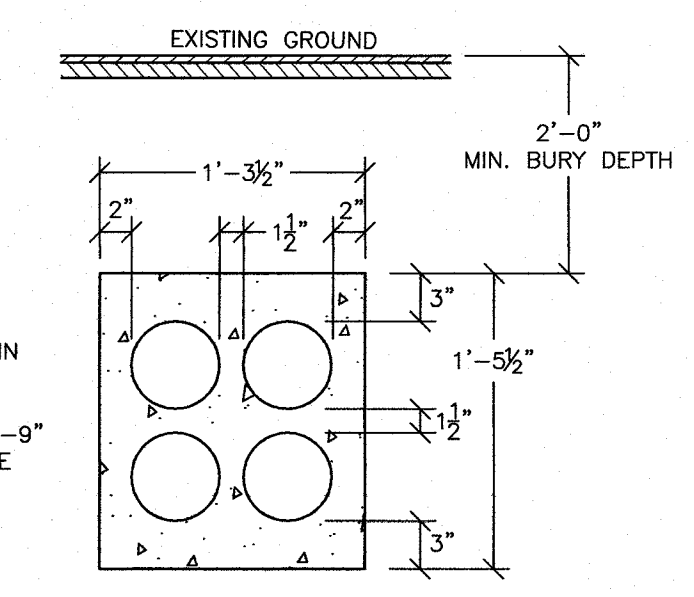

**Y** ELECTRICAL CONDUIT BANK  
 C5 NTS

**CONDUIT BANK NOTES:**

- 1) MINIMUM COVER FROM TOP OF A CONDUIT BANK TO THE SURFACE OF PAVEMENT OR EARTH SHALL BE 24". THE CONTRACTOR WILL ENSURE THAT THE DUCT BANK IS LAID WITH POSITIVE SLOPE SO THAT NO LOW POINTS DEVELOP IN THE CONDUIT THEREBY ELIMINATING THE POSSIBILITY OF WATER TO COLLECT.
- 2) CONCRETE SHALL BE 2500 PSI, 1/2" MAXIMUM STONE, 6"-9" SLUMP OF SUCH CONSISTENCY THAT SPADING WILL ENSURE THE FLOW OF CONCRETE BETWEEN AND UNDER THE INDIVIDUAL DUCTS, BUT NOT SO WET AS TO FLOAT THE DUCTS. FOR TIER BUILDUP CONSTRUCTION, A STIFFER CONSISTENCY SHOULD BE USED.

**AMBIT ENGINEERING, INC.**  
 Civil Engineers & Land Surveyors  
 200 Griffin Road, Unit 3  
 Portsmouth, N.H. 03801-7114  
 Tel (603) 430-9282  
 Fax (603) 436-2315

- NOTES:**
- 1) THE CONTRACTOR SHALL NOTIFY DIG SAFE AT 1-888-DIG-SAFE (1-888-344-7233) AT LEAST 72 HOURS PRIOR TO COMMENCING ANY EXCAVATION ON PUBLIC OR PRIVATE PROPERTY.
  - 2) UNDERGROUND UTILITY LOCATIONS ARE BASED UPON BEST AVAILABLE EVIDENCE AND ARE NOT FIELD VERIFIED. LOCATING AND PROTECTING ANY ABOVEGROUND OR UNDERGROUND UTILITIES IS THE SOLE RESPONSIBILITY OF THE CONTRACTOR AND/OR THE OWNER. UTILITY CONFLICTS SHOULD BE REPORTED AT ONCE TO THE DESIGN ENGINEER.
  - 3) CONTRACTOR SHALL INSTALL AND MAINTAIN EROSION CONTROL MEASURES IN ACCORDANCE WITH THE "NEW HAMPSHIRE STORMWATER MANUAL, VOLUME 3, EROSION AND SEDIMENT CONTROLS DURING CONSTRUCTION. (NHDES DECEMBER 2008).

APPROVED BY THE PORTSMOUTH PLANNING BOARD

CHAIRMAN \_\_\_\_\_ DATE \_\_\_\_\_

**TAX MAP 125 LOT 2A**  
**46-64 MAPLEWOOD AVENUE**  
**PORTSMOUTH, N.H.**

NO.	DESCRIPTION	DATE
3	INSPECTION & MAINTENANCE NOTES, DETAILS V & W	1/12/18
2	DETAIL Y REMOVED, DETAIL W	12/19/17
1	DETAIL X/C5, ADDED DETAIL Y/C4	10/17/17
0	ISSUED FOR COMMENT	6/19/17

STATE OF NEW HAMPSHIRE  
 JOHN R. CHAGNON  
 PROFESSIONAL ENGINEER  
 LICENSE NO. 7951

SCALE: AS NOTED  
 JUNE 2017

**DETAILS & STORM WATER MANAGEMENT**

**D4**

J:\0951\UN1800a\UN1800a\Site Plan\_46 Maplewood\Plans & Specs\Site\090714.dwg, D4\_DETAILS



**AMBIT ENGINEERING, INC.**  
Civil Engineers & Land Surveyors

200 Griffin Road, Unit 3  
Portsmouth, N.H. 03801-7114  
Tel (603) 430-9282  
Fax (603) 436-2315

**NOTES:**

- 1) THE CONTRACTOR SHALL NOTIFY DIG SAFE AT 1-888-DIG-SAFE (1-888-344-7233) AT LEAST 72 HOURS PRIOR TO COMMENCING ANY EXCAVATION ON PUBLIC OR PRIVATE PROPERTY.
- 2) UNDERGROUND UTILITY LOCATIONS ARE BASED UPON BEST AVAILABLE EVIDENCE AND ARE NOT FIELD VERIFIED. LOCATING AND PROTECTING ANY ABOVEGROUND OR UNDERGROUND UTILITIES IS THE SOLE RESPONSIBILITY OF THE CONTRACTOR AND/OR THE OWNER. UTILITY CONFLICTS SHOULD BE REPORTED AT ONCE TO THE DESIGN ENGINEER.
- 3) CONTRACTOR SHALL INSTALL AND MAINTAIN EROSION CONTROL MEASURES IN ACCORDANCE WITH THE "NEW HAMPSHIRE STORMWATER MANUAL, VOLUME 3, EROSION AND SEDIMENT CONTROLS DURING CONSTRUCTION. (NHDES DECEMBER 2008).

APPROVED BY THE PORTSMOUTH PLANNING BOARD

CHAIRMAN \_\_\_\_\_ DATE \_\_\_\_\_

**TAX MAP 125 LOT 2A**  
**46-64 MAPLEWOOD AVENUE**  
**PORTSMOUTH, N.H.**

2	DETAIL Y; REMOVE DETAIL MM	1/12/18
1	DETAIL Y	12/19/17
0	ISSUED FOR COMMENT	6/19/17
NO.	DESCRIPTION	DATE

REVISIONS

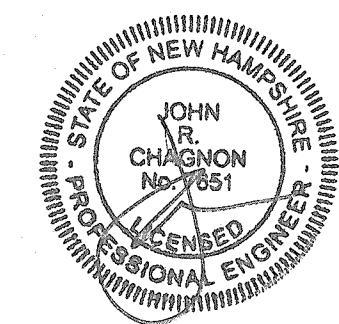

SCALE: AS NOTED JUNE 2017

**SEWER DETAILS**

**D5**

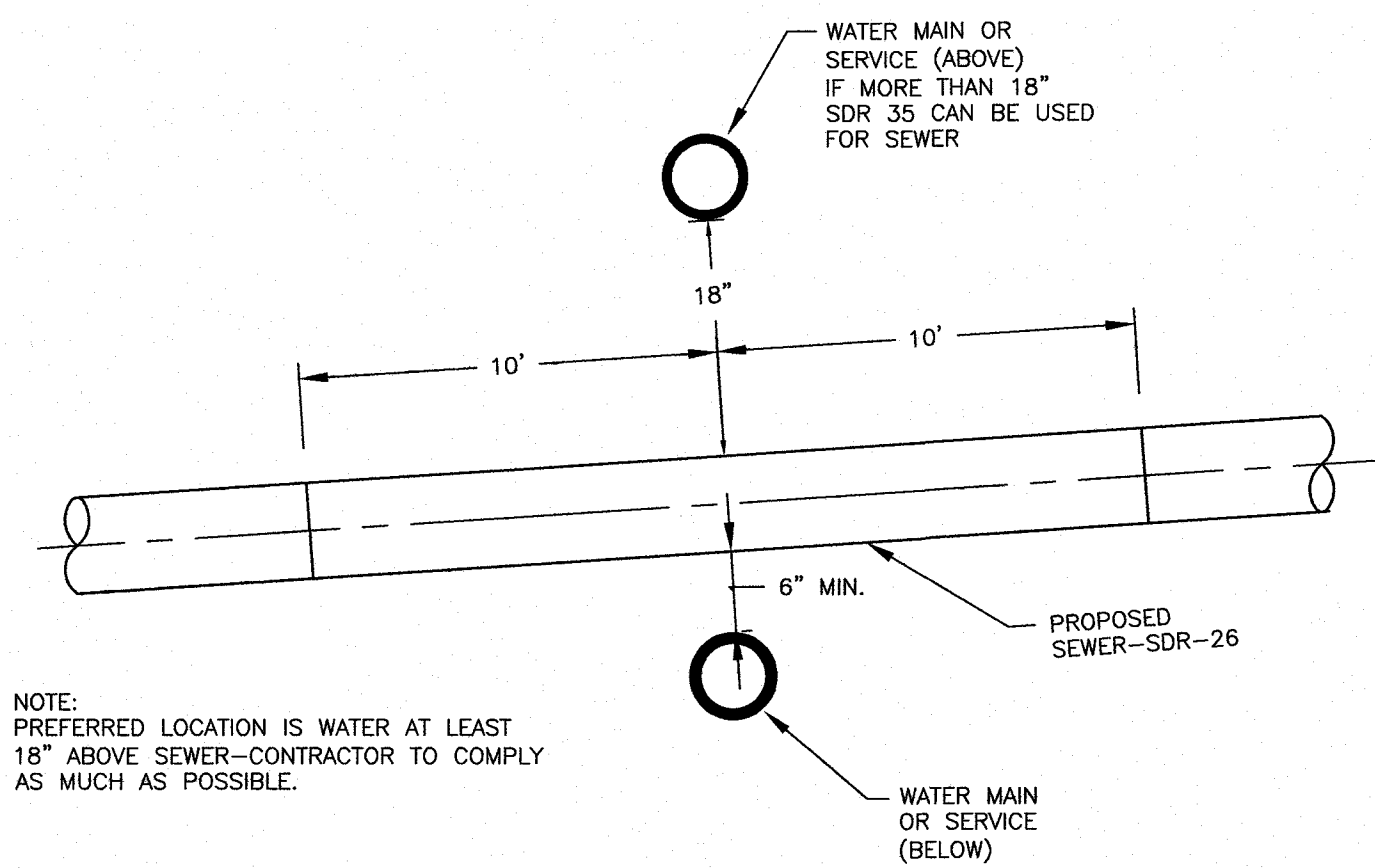

NOTE:  
PREFERRED LOCATION IS WATER AT LEAST 18" ABOVE SEWER—CONTRACTOR TO COMPLY AS MUCH AS POSSIBLE.

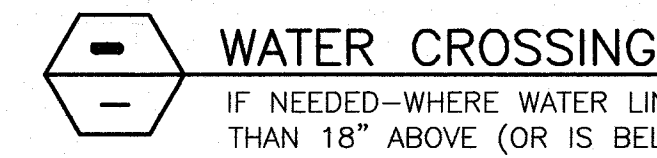

**WATER CROSSING**  
IF NEEDED—WHERE WATER LINE IS LESS THAN 18" ABOVE (OR IS BELOW) SEWER.

NTS

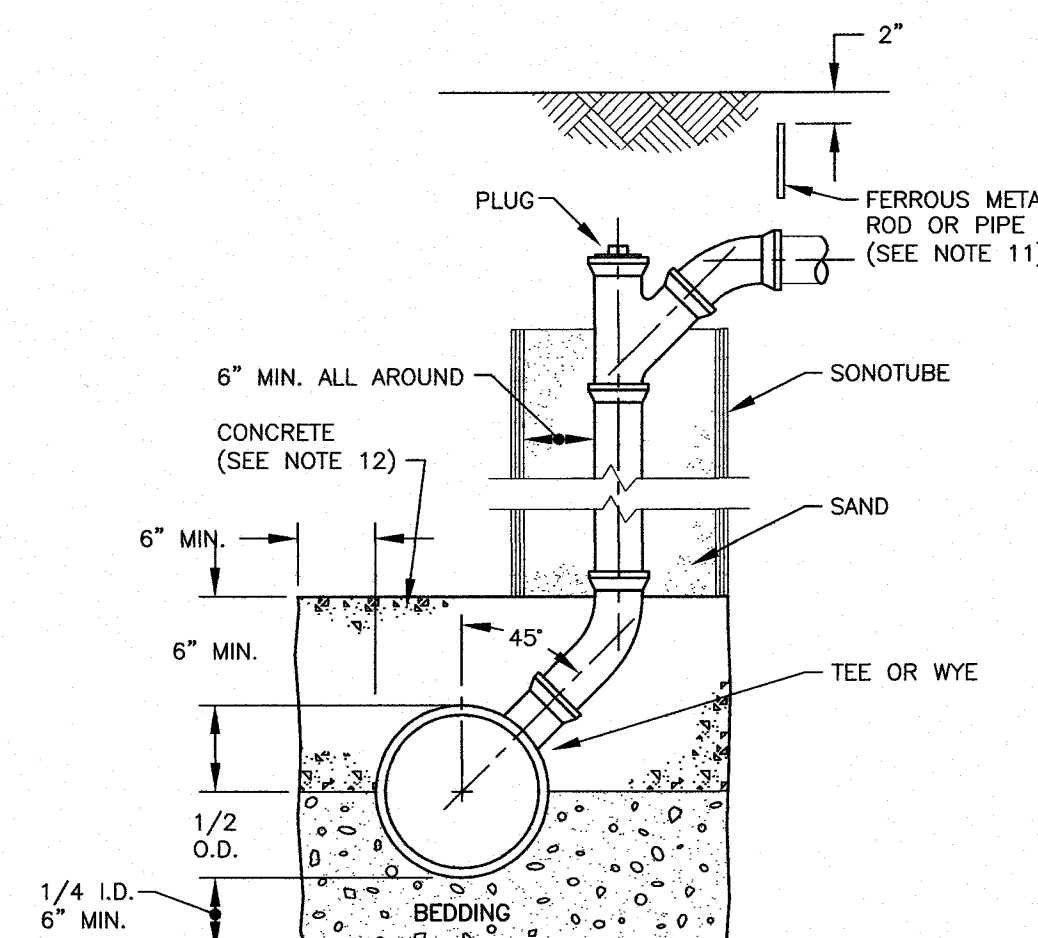

NO BACKFILLING BEFORE CONCRETE HAS TAKEN INITIAL SET (7 HRS. MIN.). BACKFILLING TO BE BROUGHT UP EVENLY ON ALL SIDES.



**CHIMNEY** (SEE NOTE 13)  
NOT TO SCALE IF NEEDED

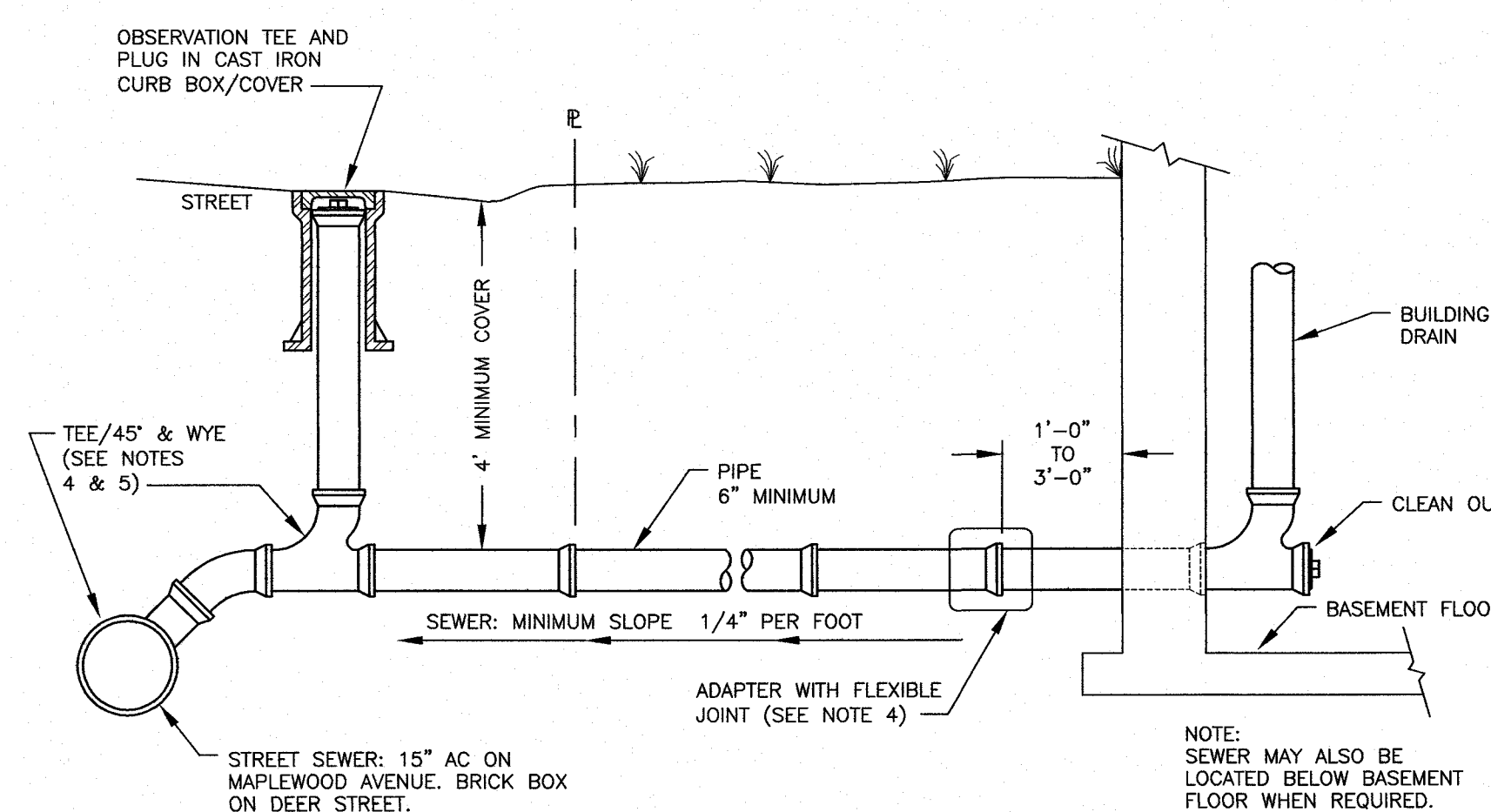

**SEWER SERVICE**  
C5 NOT TO SCALE

**GENERAL NOTES**

- 1) MINIMUM PIPE SIZE FOR COMMERCIAL SERVICE SHALL BE SIX INCHES.
- 2) PIPE AND JOINT MATERIALS:
  - A. PLASTIC SEWER PIPE
    1. PIPE AND FITTINGS SHALL CONFORM TO THE FOLLOWING ASTM STANDARDS:
 

ASTM STANDARDS	GENERIC PIPE MATERIAL	SIZES APPROVED
D3034	*PVC (SOLID WALL)	8" THROUGH 15" (SDR 35)
F679	PVC (SOLID WALL)	18" THROUGH 27" (T-1 & T-2)
F789	PVC (SOLID WALL)	4" THROUGH 18" (T-1 TO T-3)
F794	PVC (RIBBED WALL)	8" THROUGH 36"
AWWA C900	PVC (SOLID WALL)	8" THROUGH 18"

 \*PVC: POLYVINYL CHLORIDE
    2. JOINT SEALS FOR PVC PIPE SHALL BE OIL RESISTANT COMPRESSION RINGS OF ELASTOMERIC MATERIAL CONFORMING TO ASTM D-3212 AND SHALL BE PUSH-ON BELL AND SPIGOT TYPE.
  - B. DUCTILE IRON PIPE, FITTINGS AND JOINTS.
    1. DUCTILE IRON PIPE AND FITTINGS FOR SEWERS SHALL CONFORM TO THE FOLLOWING STANDARDS OF THE UNITED STATES OF AMERICA STANDARDS INSTITUTE:
      - A21.50 THICKNESS DESIGN OF DUCTILE IRON PIPE AND WITH ASTM A-536 DUCTILE IRON CASTINGS.
      - A21.51 DUCTILE IRON PIPE, CENTRIFUGALLY CAST IN METAL MOULDS OR SAND LINED MOULDS FOR SEWER APPLICATIONS.
    2. JOINTS SHALL BE OF THE MECHANICAL OR PUSH ON TYPE. JOINTS AND GASKETS SHALL CONFORM TO:
      - A21.11 RUBBER GASKET JOINTS FOR CAST IRON PRESSURE PIPE & FITTINGS.
- 3) DAMAGED PIPE SHALL BE REJECTED AND REMOVED FROM THE JOB SITE.
- 4) JOINTS SHALL BE DEPENDENT UPON A NEOPRENE OR ELASTOMERIC GASKET FOR WATER TIGHTNESS. ALL JOINTS SHALL BE PROPERLY MATCHED WITH THE PIPE MATERIALS USED. WHERE DIFFERING MATERIALS ARE TO BE CONNECTED, AS AT THE STREET SEWER WYE OR AT THE FOUNDATION WALL, APPROPRIATE MANUFACTURED ADAPTERS SHALL BE USED.
- 5) TEES AND WYES: WHERE A TEE OR WYE IS NOT AVAILABLE IN THE EXISTING STREET SEWER, AN APPROPRIATE CONNECTION SHALL BE MADE DEPENDING ON THE PIPE ENCOUNTERED, FOR PVC PIPE, USE PVC SADDLES OR INSERT-A-TEE, OR CUT IN A SANITARY TEE. FOR CLAY PIPE, USE INSERT-A-TEE OR CUT IN A SANITARY TEE. ALL WORK TO BE APPROVED BY GOVERNING BODY.
- 6) HOUSE SEWER INSTALLATION: THE PIPE SHALL BE HANDLED, PLACED AND JOINTED IN ACCORDANCE WITH INSTALLATION GUIDES OF THE APPROPRIATE MANUFACTURER. IT SHALL BE CAREFULLY BEDDED ON A 4 INCH LAYER OF CRUSHED STONE AND/OR GRAVEL AS SPECIFIED IN NOTE 10. BEDDING AND REFILL FOR DEPTH OF 12 INCHES ABOVE THE TOP OF THE PIPE SHALL BE CAREFULLY AND THOROUGHLY TAMPED BY HAND OR WITH APPROPRIATE MECHANICAL DEVICES.  
  
THE PIPE SHALL BE LAID AT A CONTINUOUS AND CONSTANT GRADE FROM THE STREET SEWER CONNECTION TO THE FOUNDATION AT A GRADE OF NOT LESS THAN 1/4 INCH PER FOOT. PIPE JOINTS MUST BE MADE UNDER DRY CONDITIONS. IF WATER IS PRESENT, ALL NECESSARY STEPS SHALL BE TAKEN TO DEWATER THE TRENCH.
- 7) TESTING: WHEN REQUIRED BY THE GOVERNING AUTHORITY, TESTING SHALL CONFORM TO ENV-WQ 704.07.
- 8) ILLEGAL CONNECTIONS: NOTHING BUT SANITARY WASTE FLOW FROM DWELLING TOILETS, SINKS, LAUNDRY ETC. SHALL BE PERMITTED. ROOF LEADERS, FOOTING DRAINS, SUMP PUMPS OR OTHER SIMILAR CONNECTIONS CARRYING RAIN WATER, DRAINAGE OR GROUND WATER SHALL NOT BE PERMITTED.
- 9) WATER SERVICE SHALL NOT BE LAID IN SAME TRENCH AS SEWER SERVICE, UNLESS IT IS ON A SHELF 12" HIGHER, AND 18" APART.
- 10) BEDDING: SCREENED GRAVEL AND/OR CRUSHED STONE, FREE FROM CLAY, LOAM, ORGANIC MATTER AND MEETING ASTM C33 STONE SIZE NO. 67.
 

100% PASSING	1 INCH SCREEN
90%-100% PASSING	3/4 INCH SCREEN
20%- 55% PASSING	3/8 INCH SCREEN
0%- 10% PASSING	#4 SIEVE
0%- 5% PASSING	#8 SIEVE

WHERE ORDERED BY THE ENGINEER TO STABILIZE THE TRENCH BASE, GRADED SCREENED GRAVEL OR CRUSHED STONE 1/2 INCH TO 1-1/2 INCH SHALL BE USED.

- 11) LOCATION: THE LOCATION OF THE TEE OR WYE SHALL BE RECORDED AND FILED IN THE MUNICIPAL RECORDS. IN ADDITION, A FERROUS METAL ROD OR PIPE SHALL BE PLACED OVER THE TEE OR WYE AS DESCRIBED IN THE TYPICAL "CHIMNEY" DETAIL, TO AID IN LOCATING THE BURIED PIPE WITH A DIP NEEDLE OR PIPE FINDER.

- 12) CAST-IN-PLACE CONCRETE: SHALL CONFORM TO THE REQUIREMENTS FOR CLASS A (3000 PSI) CONCRETE OF THE NEW HAMPSHIRE DEPARTMENT OF TRANSPORTATION STANDARD SPECIFICATIONS AS FOLLOWS:
 

CEMENT:	6.0 BAGS PER CUBIC YARD
WATER:	5.75 GALLONS PER BAG OF CEMENT
MAXIMUM AGGREGATE SIZE:	3/4 INCH

- 13) CHIMNEYS: IF VERTICAL DROP INTO SEWER IS GREATER THAN 4 FEET, A CHIMNEY SHALL BE CONSTRUCTED FOR THE HOUSE CONNECTION. CHIMNEY INSTALLATION AS RECOMMENDED BY THE PIPE MANUFACTURER MAY BE USED IF APPROVED BY THE ENGINEER.

- 14) BACKFILL UP TO SUBBASE GRAVEL SHALL BE WITH EXCAVATED SOIL FROM TRENCHING OPERATIONS. COMPACT IN 8" LIFTS WITH VIBRATORY PLATE COMPACTORS TO 90% OF MODIFIED PROCTOR DENSITY. IF FINE-GRAINED, COMPACT WITH POGO STICKS OR SHEEPSFOOT ROLLERS. PLACE NO LARGE ROCKS WITHIN 24" OF PIPE. TRENCHES THAT ARE NOT ADEQUATELY COMPACTED SHALL BE RE-EXCAVATED AND BACKFILLED UNDER THE SUPERVISION OF THE DESIGN ENGINEER OR GOVERNING BODY. UNSUITABLE BACKFILL MATERIAL INCLUDES CHUNKS OF PAVEMENT, TOPSOIL, ROCKS OVER 6" IN SIZE, MUCK, PEAT OR PIECES OF PAVEMENT.

- 15) THE CONTRACTOR IS SOLELY RESPONSIBLE FOR JOB-SITE SAFETY AND COMPLIANCE WITH GOVERNING REGULATIONS.

**GENERAL NOTES, cont'd**

- 16) ORDERED EXCAVATION OF UNSUITABLE MATERIAL BELOW GRADE. REFILL WITH BEDDING MATERIAL. FOR TRENCH WIDTH SEE TRENCH DETAIL.

- 17) SAND BLANKET: CLEAN SAND, FREE FROM ORGANIC MATTER, SO GRADED THAT 90% - 100% PASSES A 1/2 INCH SIEVE AND NOT MORE THAN 15% WILL PASS A #200 SIEVE. BLANKET MAY BE OMITTED FOR DUCTILE IRON AND REINFORCED CONCRETE PIPE PROVIDED THAT NO STONE LARGER THAN 2 INCHES IS IN CONTACT WITH THE PIPE.

- 18) BASE COURSE GRAVEL, IF ORDERED BY THE ENGINEER, SHALL MEET THE REQUIREMENTS OF DIVISION 300 OF THE LATEST EDITION OF THE:
 

STANDARD SPECIFICATIONS FOR ROAD AND BRIDGE CONSTRUCTION OF THE STATE OF NEW HAMPSHIRE, DEPARTMENT OF TRANSPORTATION.

- 19) FOR CROSS COUNTRY CONSTRUCTION, BACKFILL OR FILL SHALL BE MOUND TO A HEIGHT OF 6 INCHES ABOVE THE ORIGINAL GROUND SURFACE.

- 20) IF FULL ENCASEMENT IS UTILIZED, DEPTH OF CONCRETE BELOW PIPE SHALL BE 1/4 I.D. (4" MIN.) BLOCK SUPPORT SHALL BE SOLID CONCRETE BLOCKS.

- 21) CONTRACTOR SHALL INSTALL AND MAINTAIN EROSION CONTROL MEASURES IN ACCORDANCE WITH THE "NEW HAMPSHIRE STORMWATER MANUAL, VOLUME 3, EROSION AND SEDIMENT CONTROLS DURING CONSTRUCTION. (NHDES DECEMBER 2008).

- 22) THE CONTRACTOR SHALL NOTIFY DIG SAFE AT 1-888-DIG-SAFE (1-888-344-7233) AT LEAST 72 HOURS PRIOR TO COMMENCING ANY EXCAVATION.

- 23) THE PURPOSE OF THIS PLAN IS TO SHOW STANDARDS FOR SEWER CONSTRUCTION.

- 24) ALL WORK SHALL BE IN COMPLIANCE WITH NHDES CODE OF ADMINISTRATIVE RULES PART ENV-WQ 704 DESIGN OF SEWERS.

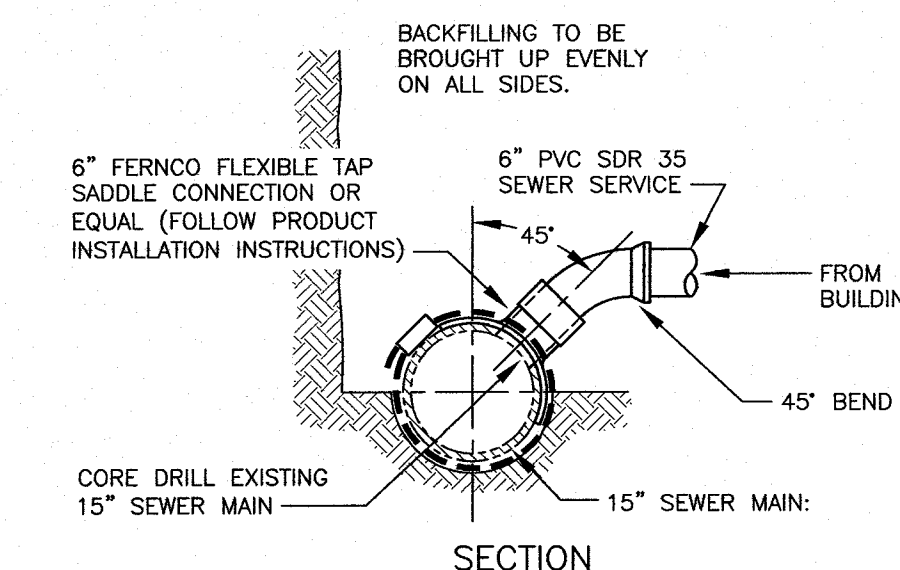

**SEWER SERVICE CONNECTION DETAIL**  
C5 (AC PIPE) NTS

NOTE: COORDINATE DESIGN OF BRICK BOX SEWER CONNECTION WITH CITY OF PORTSMOUTH DPW. PROVIDE SHOP DRAWINGS FOR REVIEW.

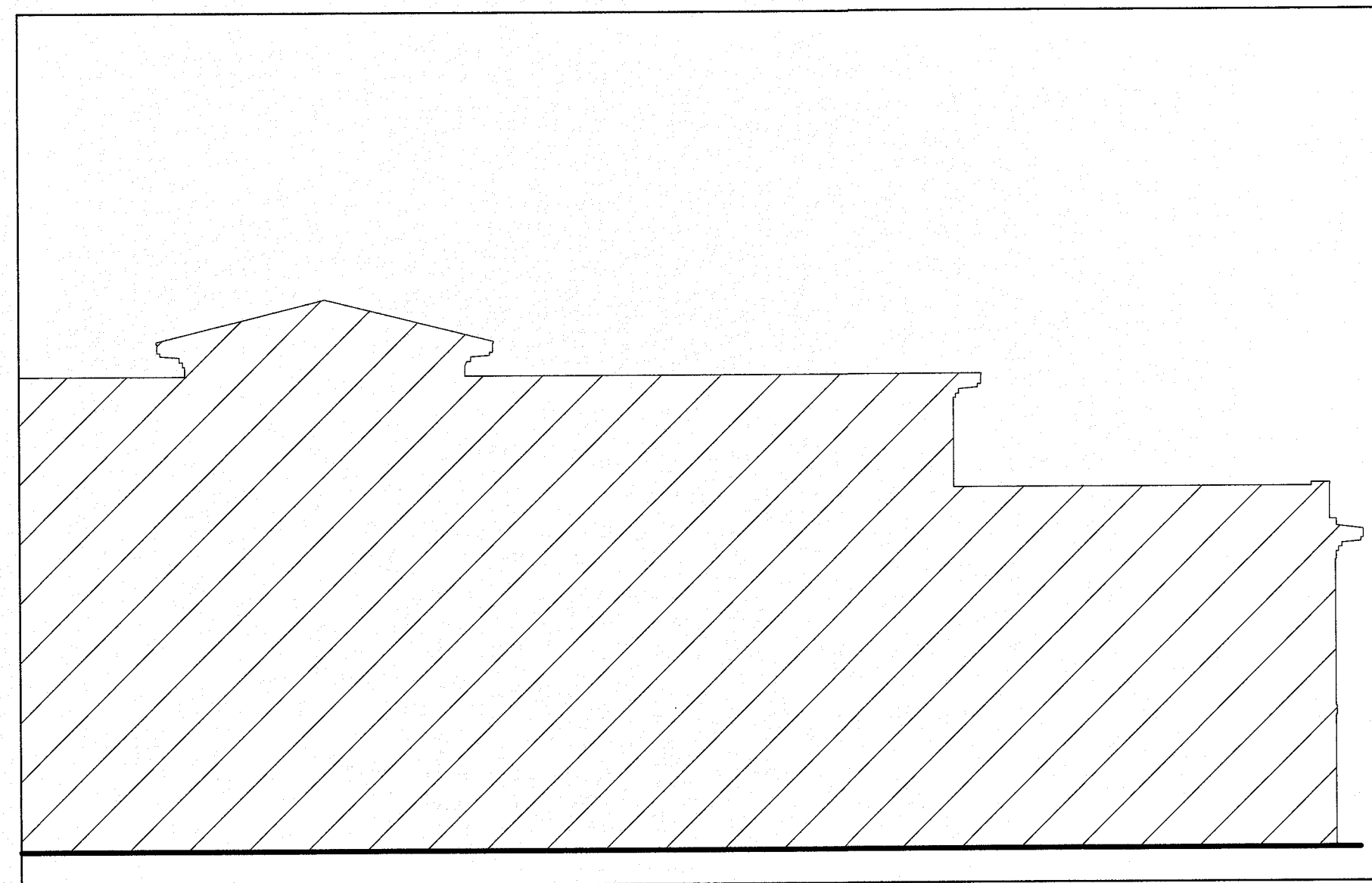

Maplewood Avenue  
3/32" = 1'-0"

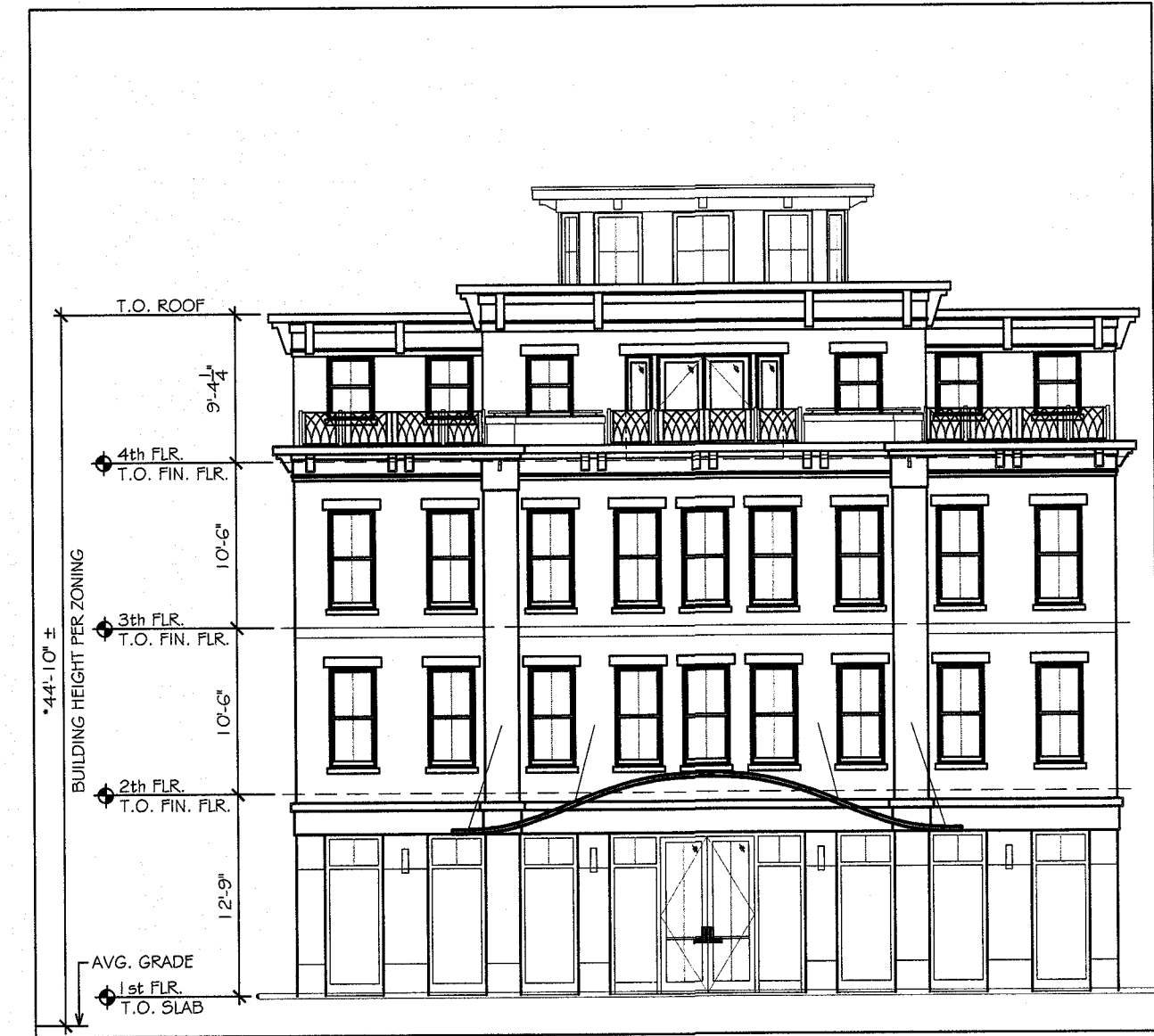

Maplewood Intersection  
3/32" = 1'-0"



Deer Street  
3/32" = 1'-0"



Pedestrian Way Between Phase 1 and 2  
3/32" = 1'-0"



Pedestrian Way Between Phase 2 and VFW (BRIDGE ST.)  
3/32" = 1'-0"

REVISIONS:

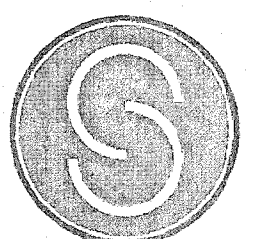

SOMMA

36 Maplewood Avenue  
Portsmouth, NH 03801  
PH: 603.766.3760

46-64 Maplewood  
Avenue  
Portsmouth, NH

TITLE:  
ELEVATIONS

SCALE: AS NOTED  
DRAWN BY: SOMMA  
CHECKED BY:  
PROJECT NO.: -  
DATE: JANUARY 30, 2018

ARCH

**AMBIT ENGINEERING, INC.** CIVIL ENGINEERS AND LAND SURVEYORS

200 Griffin Road, Unit 3, Portsmouth, NH 03801  
Phone (603) 430-9282 Fax 436-2315

15 January, 2018

Juliet Walker, Chair  
City of Portsmouth Technical Advisory Committee  
1 Junkins Avenue  
Portsmouth, NH 03801

**RE: Application for Site Plan Review for 46 – 64 Maplewood Avenue, Portsmouth**

Dear Ms. Walker:

On behalf of 30 Maplewood, LLC, we hereby submit our response to the comments received in advance of the January 2, 2018 Technical Advisory Committee Meeting. Included are the comments, with responses in **bold** text:

1. All aspects of the site work shall be substantially complete prior to occupancy. **OK.**
2. The applicant shall contribute to the cost for the replacement of the water main from the corner of Deer and Bridge up to the intersection of the mains in Maplewood Ave. **Applicant will pay fair share of this cost. We understand that the cost and formula will be presented to the team prior to the January 30 TAC Meeting.** The applicant will also be responsible for the services for the VFW, the proposed building and the cost of the hydrant. **Applicant will pay fair share of the cost associated with connecting the VFW to the new water main, from the main to the property line, connecting with the existing service. Upgrading the service beyond the property line, if desired, should be the VFW's cost. The cost of the hydrant re-connection should be a part of the fair share total cost.**
3. The applicant shall either construct or pay for the construction of a new sewer lateral for the VFW to connect from the building to the brick sewer main so that the AC sewer main can be removed for the water main project. **The cost of the VFW sewer re-connection should be a part of the fair share total cost. Sheet C5, Note 13 addresses this issue.**
4. To verify that the new building's sewer connection is in the brick sewer and not the AC sewer, the sewer stub that is shown will most likely not be able to be used. A new connection to the main should be shown for both services. **Notes in this regard have been added to Sheet C5.**
5. The line type on the plans for the old utilities (gas etc.) that are no longer in service on Deer and Bridge should either be removed or changed. The only gas main still in service is the one approximately 3' from the curb line and that main now goes into

Maplewood Avenue. The patch for the work is evident in the road. **This has been corrected on Sheet C1.**

6. The applicant should verify that a 2” copper line is large enough for the planned uses of the building. **The plan has been revised to a 4 inch connection – Sheet C5.**
7. The proposed gas service should not be located so close to the entrance of the garage. The gas company will require substantial bollards/protection in that location. **The gas service location has been revised as suggested – Sheet C5.**
8. Inside the garage, the first row of stacked spaces should be much wider than shown, as it is directly adjacent to a wall. The end spaces should be at least 10’ wide with the middle spaces all being the same width spaced out equally. **The plan has been revised as suggested – Sheet C4.**
9. Tree species to be approved by Trees and Greenery. **Woodburn & Company met with the Trees and Greenery Committee on January 10 and received approval for the tree species.**
10. The applicant will need a license for the Silva cells they are showing. **The license will be for the roof drains designed to water the City street trees. Please refer to the Easement and License Plan for the location, and the “License Agreement for 46 Maplewood Avenue, LLC”, included in the submission, for the proposed legal document for review.**
11. The conduit under the sidewalks is shown incorrectly. The street lights will require a 2” conduit run that is totally separate from the power going to the City’s controller/VFW building. Provide 2 lighting pull boxes, one at each street corner. **The conduit run has been labelled, and the pull boxes (handhole) added to Sheet C5 with a Detail on Sheet D3.**
12. Show the proposed conduit plan for the building’s power supply for comment. **The location has been revised and is shown on Sheet C5.**
13. Brick pavers for the project shall be as manufactured by Pinehall 4”x8” the new std. Samples will need to be provided to and approved by the DPW. **The revision, as suggested, is shown on Sheet C2 and Detail H on Sheet D2.**
14. All street curbing around the site shall be reset during the project. **The revision, as suggested, is noted on Sheet C6.**
15. Verify that all sidewalks can be built with no more than 2% and no less than 1% slope. **This is the case with the design, see Sheet C6.**
16. The cobble detail does show thermal finish but it does not specify thickness (should be at least 3” on top of 4” of asphalt). It also doesn’t specify ashlar sides for a flat surface. **The revision, as suggested, is shown on Sheet D2.** Note should also indicate that if this is approved, it is the applicant’s responsibility to keep this in good repair and repair within 90 days’ notice of defect from the City. **The revision, as suggested, has been incorporated on the License Plan and the “License Agreement for 46 Maplewood Avenue, LLC”, included in the submission, is the proposed legal document for review.**

17. The applicant has changed the proposed lights in the City sidewalk. These shall be changed back to the City Standard fixture. **The revision, as suggested, is noted on Sheet L1.**
18. Shouldn't the tide flex valve in the drainage system be on the outlet pipe? **The location is on the outlet pipes on the applicant's property to allow for responsibility of Maintenance to be the applicant's – Sheet C6.**
19. The drain pipe that is 30' east of the garage is still labeled as an underdrain. **The pipe is a roof drain, revision noted on Sheet C6.**
20. The applicant shall contribute to the City's storm water master plan study for this area. **Applicant will pay our fair share; as we understand it the City will provide pricing and formula for payment before the TAC Meeting for review.** Confirm that there will be no groundwater discharge into the drainage system. **There is no proposed groundwater discharge in to the City's drainage system. Also see Note 5 on Sheet C6.**
21. No profile of the garage driveway shown. Has it changed since the previous submittal? Grade changes should be no more than 10% for a crest and 9% for a sag. **The garage driveway is actually a garage ramp; a profile is submitted herewith for review. We believe the grades are appropriate for a garage ramp. See Sheet P1.**
22. Have groundwater elevations been monitored through at least one tidal cycle to determine if there are potential drainage impacts from tidal waters? It may be necessary to provide back flow preventers in catch basins to prevent tidal storm water from entering site through catch basins and other drainage structures. **We are providing backflow prevention as suggested.**
23. Parallel parking spaces that you indicated were removed on the site plan should also be removed from the landscape plan and the easement plan. **The revision, as suggested, is noted on Sheet L1 and the Easement Plan.**
24. On sheet C6, your reference to the curbing references the reveal, not the width. TAC requests that any new curbing shall match existing or be 6" in width. I believe the standard reveal is 5", but DPW can confirm. **The revision, as suggested, is noted on Sheet C6.**
25. The detail for the sewer line on sheet D5 still appears to reference encasing the sewer lines in concrete, please explain. **The detail and notes regarding sewer line / water line separation have been revised – Sheet D5.**
26. Is the process for eliminating groundwater intrusion for the foundation work that you reference in the cover letter reflected in a note or detail in the plan set? **The Foundation design will include the necessary Geotechnical review. This is noted on Sheet C6, Note 5.**
27. Additional bike racks should be added along the sidewalk closer to building entrances. **The revision, as suggested, is noted on Sheet L1.**
28. Any landscaping you show as part of this site plan approval (including off-site) will be required to be implemented as part of this site plan. **Agreed; the landscaping has been revised to NOT include any work on the VFW Property. See former**

**agreement to landscape in the Supplemental Information. The previously proposed landscaping on VFW property will not be going forward given the upcoming change in ownership of the VFW property.**

29. Add boundary lines to plan legends, it is not easy to distinguish between easement lines and property lines, etc. On easement plan, cross hatching is useful for showing easement areas. **The revisions, as suggested, are noted on the Cover Sheet and the Easement Plan.**
30. Please provide more of an explanation of who the various easements benefit, e.g. the pedestrian easement from Deer St between VFW and future building. Who is that for? **More information, as suggested, is noted on the Easement Plan.**
31. On easement plan, does the area referenced in note 8 coincide with the 5' utility easement? **No; the intent was that the easement goes from face of building to face of building. Note 8 has been replaced; see the hatched location.** Who is the access easement for? **The public under an easement to the City of Portsmouth. Also see the "Easement Deed" submitted in the supplemental information for legal review.**
32. On easement plan, note 9, this should be determined prior to site plan approval. **This note has been removed from the Easement Plan.**
33. On easement plan, note 10, reference this note on the plan at dumpster location. **The revision, as suggested, is noted on Sheet C3.**
34. On L-1, the Conditional Use Permit Qualifying Criteria should be moved to the site plan (with zoning requirements). **The revision, as suggested, is noted on Sheet C3 and deleted from Sheet L1.**
35. On site plan, add proposed total height of building to the zoning information. **The revision, as suggested, is noted on Sheet C3.**
36. Note 7, please remove. Uses shown are not conceptual. If the use changes, then a site plan amendment or change of use approval will be required. **The note, as suggested, has been removed.**
37. Note 8, add reference to condo docs which specify this. **The revision, as suggested, is noted on Sheet C3.**
38. You included the inspection and maintenance plan for stormwater management. Where is this referenced in the plan set? **The revision, as suggested, is noted on Sheet D4.**
39. Statements required per Section 2.13.3 should be included on Site Plan and Easement Plan. **The revision, as suggested, is noted on Sheet C3 as Note 3.**
40. A note should be included on snow storage/removal. **The revision, as suggested, is noted on Sheet C3 as Note 7.**
41. Existing/proposed open space should be included in plan set. **Calculation is Note 2 on Sheet C3.**
42. Indicate where Low Impact Development Design practices have been incorporated. Checklist references Sheet C-6, the Grading and Drainage Plan, without further explanation. **See the Application Checklist and Sheet C6.**

43. Where does the exit beside the ramp from the garage discharge? It is not shown on the first floor. Does it discharge directly outside? **Yes, it does discharge directly outside, and shows on the revised first floor plan.**
44. Neither of the exits from the basement mercantile space appear to discharge directly outside. One discharges into the street level garage accessed from Bridge St and the other leads up a ramp and then into the center stairwell. These exits do not appear to meet the remoteness criteria. **The stair which discharges into the Bridge Street garage does discharge outside. That is an open air public pass through. The two exits do meet remoteness criteria as shown in the Supplemental Information plan titled "EGRESS".**
45. Where is the center stairwell enclosed on the first floor? **Architectural plans to address this issue.**
46. Clarify ownership/maintenance responsibility of drainage system in the parking area on Lot 1. Include note on plan regarding maintenance responsibility and maintenance requirements. **The revision, as suggested, is noted on the Easement Plan as Note 9. 46 Maplewood will be the responsible party. Also see the "Mutual Easements Agreement" submitted in the supplemental information for legal review.**
47. Why is proposed landscaping shown for 238 Deer St. (VFW) property? This landscaping might conflict with proposed use of VFW building. **The landscaping was allowed under an existing agreement; but this was removed from the plan set.**
48. Relocated hydrant is shown on private property (VFW). **The hydrant location was moved to the curb line as requested – Sheet C5.**
49. Proposed 6" drain pipe connected to roof drains are shown in City ROW. OCS #2 detail does not appear consistent with Grading & Drainage Plan (C6) and the modelling of unit in drainage report. **The model is correct; all Silva Cell trunk lines are 6 inch.**
50. This property is governed by the zoning requirements of 2014 where a conditional use permit could be requested from the HDC to increase the height of the building to up to 60 feet or 5 stories. In this case, the applicant received approval for a CUP to allow for a 50 foot building with 4 stories. **Agreed; and also agree with the TAC Committee's determination that the building should be labelled as "5 Story".**
51. The applicant should confirm that all existing (30 Maplewood Ave.) or proposed openings meet the fire separation requirements. If not, easements should be required to maintain compliance. **See the Easement and License Plan as well as the plan submitted with the Supplemental Information titled "Building Opening Calculations".**
52. Trees and Greenery should review and approve the proposed street trees. **Approved on January 10<sup>th</sup>.**
53. The parking calculations should be revised to reflect the recently adopted parking requirements. The SF of the residential units needs to be listed to determine the parking requirement and a waiver may be required to allow for excess parking. **The site was grandfathered to 2014 Zoning; therefore this calculation is not required.**



Please feel free to call if you have any questions or comments. We look forward to the TAC Committee's review at the January 30, 2018 meeting.

Sincerely,

John Chagnon, PE  
CC (via email): Steve Kelm, Paul McEachern



# City of Portsmouth, New Hampshire

## Site Plan Application Checklist

This site plan application checklist is a tool designed to assist the applicant in the planning process and for preparing the application for Planning Board review. A pre-application conference with a member of the planning department is strongly encouraged as additional project information may be required depending on the size and scope. The applicant is cautioned that this checklist is only a guide and is not intended to be a complete list of all site plan review requirements. Please refer to the Site Plan review regulations for full details.

**Applicant Responsibilities (Section 2.5.2):** Applicable fees are due upon application submittal along with required attachments. The application shall be complete as submitted and provide adequate information for evaluation of the proposed site development. Waiver requests must be submitted in writing with appropriate justification.

Name of Owner/Applicant: 30 Maplewood, LLC Date Submitted: 01-16-2018

Phone Number: Ambit (603) 430-9282 E-mail: jrc@ambitengineering.com

Site Address: 30 Maplewood Avenue, Portsmouth, NH Map: 125 Lot: 2A

Project: 64 Maplewood Zoning District: CD-4L Lot area: 21,798 sq. ft.

Application Requirements			
<input checked="" type="checkbox"/>	Required Items for Submittal	Item Location (e.g. Page or Plan Sheet/Note #)	Waiver Requested
<input checked="" type="checkbox"/>	Fully executed and signed Application form. <b>(2.5.2.3)</b>	AT CITY PLANNING	N/A
<input checked="" type="checkbox"/>	All application documents, plans, supporting documentation and other materials provided in digital Portable Document Format (PDF) on compact disc, DVD or flash drive. <b>(2.5.2.8)</b>	PROVIDED WITH SUBMITAL	N/A

Site Plan Review Application Required Information			
<input checked="" type="checkbox"/>	Required Items for Submittal	Item Location (e.g. Page/line or Plan Sheet/Note #)	Waiver Requested
<input checked="" type="checkbox"/>	Statement that lists and describes "green" building components and systems. <b>(2.5.3.1A)</b>	SUPPLEMENTAL INFORMATION	
<input checked="" type="checkbox"/>	Gross floor area and dimensions of all buildings and statement of uses and floor area for each floor. <b>(2.5.3.1B)</b>	SHEET C3	
<input checked="" type="checkbox"/>	Tax map and lot number, and current zoning of all parcels under Site Plan Review. <b>(2.5.3.1C)</b>	SHEET C1	
<input checked="" type="checkbox"/>	Owner's name, address, telephone number, and signature. Name, address, and telephone number of applicant if different from owner. <b>(2.5.3.1D)</b>	COVER SHEET	

**Site Plan Review Application Required Information**

<input checked="" type="checkbox"/>	<b>Required Items for Submittal</b>	<b>Item Location (e.g. Page/line or Plan Sheet/Note #)</b>	<b>Waiver Requested</b>
<input checked="" type="checkbox"/>	Names and addresses (including Tax Map and Lot number and zoning districts) of all direct abutting property owners (including properties located across abutting streets) and holders of existing conservation, preservation or agricultural preservation restrictions affecting the subject property. <b>(2.5.3.1E)</b>	SHEET C1	
<input checked="" type="checkbox"/>	Names, addresses and telephone numbers of all professionals involved in the site plan design. <b>(2.5.3.1F)</b>	COVER SHEET	
<input checked="" type="checkbox"/>	List of reference plans. <b>(2.5.3.1G)</b>	EASEMENT PLAN	
<input checked="" type="checkbox"/>	List of names and contact information of all public or private utilities servicing the site. <b>(2.5.3.1H)</b>	COVER SHEET	

**Site Plan Specifications**

<input checked="" type="checkbox"/>	<b>Required Items for Submittal</b>	<b>Item Location (e.g. Page/line or Plan Sheet/Note #)</b>	<b>Waiver Requested</b>
<input checked="" type="checkbox"/>	Full size plans shall not be larger than 22 inches by 34 inches with match lines as required, unless approved by the Planning Director. Submittals shall be a minimum of 11 inches by 17 inches as specified by Planning Dept. staff. <b>(2.5.4.1A)</b>	Required on all plan sheets	N/A
<input checked="" type="checkbox"/>	Scale: Not less than 1 inch = 60 feet and a graphic bar scale shall be included on all plans. <b>(2.5.4.1B)</b>	Required on all plan sheets	N/A
<input checked="" type="checkbox"/>	GIS data should be referenced to the coordinate system New Hampshire State Plane, NAD83 (1996), with units in feet. <b>(2.5.4.1C)</b>	Required on all plan sheets	N/A
<input checked="" type="checkbox"/>	Plans shall be drawn to scale. <b>(2.5.4.1D)</b>	Required on all plan sheets	N/A
<input checked="" type="checkbox"/>	Plans shall be prepared and stamped by a NH licensed civil engineer. <b>(2.5.4.1D)</b>	Required on all plan sheets	N/A
<input type="checkbox"/>	Wetlands shall be delineated by a NH certified wetlands scientist. <b>(2.5.4.1E)</b>	N/A	N/A
<input type="checkbox"/>	Wetland delineations shall be stamped by a NH certified wetlands scientist. <b>(2.5.4.1E)</b>	N/A	N/A
<input checked="" type="checkbox"/>	Title (name of development project), north point, scale, legend. <b>(2.5.4.2A)</b>	Required on all plan sheets	N/A
<input checked="" type="checkbox"/>	Date plans first submitted, date and explanation of revisions. <b>(2.5.4.2B)</b>	Required on all plan sheets	N/A
<input checked="" type="checkbox"/>	Individual plan sheet title that clearly describes the information that is displayed.	Required on all plan sheets	N/A

<b>Site Plan Specifications</b>			
<input checked="" type="checkbox"/>	<b>Required Items for Submittal</b>	<b>Item Location (e.g. Page/line or Plan Sheet/Note #)</b>	<b>Waiver Requested</b>
	<b>(2.5.4.2C)</b>		
<input checked="" type="checkbox"/>	Source and date of data displayed on the plan. <b>(2.5.4.2D)</b>	Required on all plan sheets	N/A
<input checked="" type="checkbox"/>	A note shall be provided on the Site Plan stating: "All conditions on this Plan shall remain in effect in perpetuity pursuant to the requirements of the Site Plan Review Regulations." <b>(2.5.4.2E)</b>	Required on all plan sheets  COVER SHEET	N/A
<input checked="" type="checkbox"/>	Plan sheets submitted for recording shall include the following notes: <ul style="list-style-type: none"> <li>a. "This Site Plan shall be recorded in the Rockingham County Registry of Deeds."</li> <li>b. "All improvements shown on this Site Plan shall be constructed and maintained in accordance with the Plan by the property owner and all future property owners. No changes shall be made to this Site Plan without the express approval of the Portsmouth Planning Director."</li> </ul> <b>(2.13.3)</b>	SHEET C3	N/A
<input checked="" type="checkbox"/>	Plan sheets showing landscaping and screening shall also include the following additional notes: <ul style="list-style-type: none"> <li>a. "The property owner and all future property owners shall be responsible for the maintenance, repair and replacement of all required screening and landscape materials."</li> <li>b. "All required plant materials shall be tended and maintained in a healthy growing condition, replaced when necessary, and kept free of refuse and debris. All required fences and walls shall be maintained in good repair."</li> <li>c. "The property owner shall be responsible to remove and replace dead or diseased plant materials immediately with the same type, size and quantity of plant materials as originally installed, unless alternative plantings are requested, justified and approved by the Planning Board or Planning Director."</li> </ul> <b>(2.13.4)</b>	SHEET L1	N/A

**Site Plan Specifications – Required Exhibits and Data**

<input checked="" type="checkbox"/>	1. Existing Conditions: (2.5.4.3A)	Item Location (e.g. Page/line or Plan Sheet/Note #)	Waiver Requested
<input checked="" type="checkbox"/>	a. Surveyed plan of site showing existing natural and built features;	SHEET C1	
<input checked="" type="checkbox"/>	b. Zoning boundaries;	COVER SHEET	
<input checked="" type="checkbox"/>	c. Dimensional Regulations;	SHEET C1	
<input checked="" type="checkbox"/>	d. Wetland delineation, wetland function and value assessment;	N/A	
<input checked="" type="checkbox"/>	e. SFHA, 100-year flood elevation line and BFE data.	SHEET C1	
	<b>2. Buildings and Structures: (2.5.4.3B)</b>		
<input checked="" type="checkbox"/>	a. Plan view: Use, size, dimensions, footings, overhangs, 1st fl. elevation;	ARCHITECTURAL PLANS	
<input checked="" type="checkbox"/>	b. Elevations: Height, massing, placement, materials, lighting, façade treatments;	ARCHITECTURAL PLANS	
<input checked="" type="checkbox"/>	c. Total Floor Area;	SHEET C3	
<input checked="" type="checkbox"/>	d. Number of Usable Floors;	SHEET C3	
<input checked="" type="checkbox"/>	e. Gross floor area by floor and use.	SHEET C3	
	<b>3. Access and Circulation: (2.5.4.3C)</b>		
<input checked="" type="checkbox"/>	a. Location/width of access ways within site;	SHEET C3	
<input checked="" type="checkbox"/>	b. Location of curbing, right of ways, edge of pavement and sidewalks;	SHEET C3	
<input checked="" type="checkbox"/>	c. Location, type, size and design of traffic signing (pavement markings);	SHEET C3	
<input checked="" type="checkbox"/>	d. Names/layout of existing abutting streets;	SHEET C3	
<input checked="" type="checkbox"/>	e. Driveway curb cuts for abutting prop. and public roads;	SHEET C3	
<input checked="" type="checkbox"/>	f. If subdivision; Names of all roads, right of way lines and easements noted;	EASEMENT PLAN	
<input type="checkbox"/>	g. AASHTO truck turning templates, description of minimum vehicle allowed being a WB-50 (unless otherwise approved by TAC).	N/A	
	<b>4. Parking and Loading: (2.5.4.3D)</b>		
<input checked="" type="checkbox"/>	a. Location of off street parking/loading areas, landscaped areas/buffers;	SHEET C3/C4	
<input checked="" type="checkbox"/>	b. Parking Calculations (# required and the # provided).	SHEET C3	
	<b>5. Water Infrastructure: (2.5.4.3E)</b>		
<input checked="" type="checkbox"/>	a. Size, type and location of water mains, shut-offs, hydrants & Engineering data;	SHEET C5	
<input type="checkbox"/>	b. Location of wells and monitoring wells (include protective radii).	N/A	
	<b>6. Sewer Infrastructure: (2.5.4.3F)</b>		
<input checked="" type="checkbox"/>	a. Size, type and location of sanitary sewage facilities & Engineering data.	SHEET C5	
	<b>7. Utilities: (2.5.4.3G)</b>		
<input checked="" type="checkbox"/>	a. The size, type and location of all above & below ground utilities;	SHEET C5	
<input checked="" type="checkbox"/>	b. Size type and location of generator pads, transformers and other fixtures.	SHEET C5	
<input type="checkbox"/>	<b>8. Solid Waste Facilities: (2.5.4.3H)</b>		
<input checked="" type="checkbox"/>	a. The size, type and location of solid waste facilities.	SHEET C3	
	<b>9. Storm water Management: (2.5.4.3I)</b>	Item Location	Waiver Requested

<input checked="" type="checkbox"/>	a. The location, elevation and layout of all storm-water drainage.	SHEET C6	
	<b>10. Outdoor Lighting: (2.5.4.3J)</b>		
<input checked="" type="checkbox"/>	a. Type and placement of all lighting (exterior of building, parking lot and any other areas of the site) and; b. photometric plan.	SHEET L1	
<input checked="" type="checkbox"/>	<b>11. Indicate where dark sky friendly lighting measures have been implemented. (10.1)</b>	SHEET L1	
	<b>12. Landscaping: (2.5.4.3K)</b>		
<input checked="" type="checkbox"/>	a. Identify all undisturbed area, existing vegetation and that which is to be retained;	SHEET C2	
<input checked="" type="checkbox"/>	b. Location of any irrigation system and water source.	N/A / SHEET C6	
	<b>13. Contours and Elevation: (2.5.4.3L)</b>		
<input checked="" type="checkbox"/>	a. Existing/Proposed contours (2 foot minimum) and finished grade elevations.	SHEET C6	
	<b>14. Open Space: (2.5.4.3M)</b>		
<input checked="" type="checkbox"/>	a. Type, extent and location of all existing/proposed open space.	HDC PLANS	
<input checked="" type="checkbox"/>	<b>15. All easements, deed restrictions and non-public rights of ways. (2.5.4.3N)</b>	EASMENT PLANS	
<input checked="" type="checkbox"/>	<b>16. Location of snow storage areas and/or off-site snow removal. (2.5.4.3O)</b>	SHEET C3 NOTE 7	
<input type="checkbox"/>	<b>17. Character/Civic District (All following information shall be included): (2.5.4.3Q)</b>	N/A (CUP)	
	a. Applicable Building Height (10.5A21.20 & 10.5A43.30);		
	b. Applicable Special Requirements (10.5A21.30);		
	c. Proposed building form/type (10.5A43);		
	d. Proposed community space (10.5A46).		

<b>Other Required Information</b>			
<input checked="" type="checkbox"/>	<b>Required Items for Submittal</b>	<b>Item Location (e.g. Page/line or Plan Sheet/Note #)</b>	<b>Waiver Requested</b>
<input checked="" type="checkbox"/>	Traffic Impact Study or Trip Generation Report, as required. <i>(Four (4) hardcopies of the full study/report and Six (6) summaries to be submitted with the Site Plan Application) (3.2.1-2)</i>	TRIP GENERATION REPORT SUBMITTAL	
<input checked="" type="checkbox"/>	Indicate where Low Impact Development Design practices have been incorporated. <b>(7.1)</b>	SHEET C6; WATER QUALITY UNIT & ROOF DRAINS TO SILVA CELLS	
<input checked="" type="checkbox"/>	Indicate whether the proposed development is located in a wellhead protection or aquifer protection area. Such determination shall be approved by the Director of the Dept. of Public Works. <b>(7.3.1)</b>	N/A	
<input checked="" type="checkbox"/>	Indicate where measures to minimize impervious surfaces have been implemented. <b>(7.4.3)</b>	N/A	
<input checked="" type="checkbox"/>	Calculation of the maximum effective impervious surface as a percentage of the site. <b>(7.4.3.2)</b>	N/A (PREVIOUSLY DEVELOPED)	
<input checked="" type="checkbox"/>	Stormwater Management and Erosion Control Plan. <i>(Four (4) hardcopies of the full plan/report and Six (6) summaries to be submitted with the Site Plan Application) (7.4.4.1)</i>	SHEET D4	

**Final Site Plan Approval Required Information**

<input checked="" type="checkbox"/>	Required Items for Submittal	Item Location (e.g. Page/line or Plan Sheet/Note #)	Waiver Requested
<input checked="" type="checkbox"/>	All local approvals, permits, easements and licenses required, including but not limited to: <ul style="list-style-type: none"> <li>a. Waivers;</li> <li>b. Driveway permits;</li> <li>c. Special exceptions;</li> <li>d. Variances granted;</li> <li>e. Easements;</li> <li>f. Licenses.</li> </ul> <b>(2.5.3.2A)</b>	<ul style="list-style-type: none"> <li>a. N/A</li> <li>b. SITE PLAN REVIEW</li> <li>c. N/A</li> <li>d. SHEET C4; NOTE 10</li> <li>e. EASEMENT PLAN</li> <li>f. LICENSE PLAN</li> </ul>	
<input checked="" type="checkbox"/>	Exhibits, data, reports or studies that may have been required as part of the approval process, including but not limited to: <ul style="list-style-type: none"> <li>a. Calculations relating to stormwater runoff;</li> <li>b. Information on composition and quantity of water demand and wastewater generated;</li> <li>c. Information on air, water or land pollutants to be discharged, including standards, quantity, treatment and/or controls;</li> <li>d. Estimates of traffic generation and counts pre- and post-construction;</li> <li>e. Estimates of noise generation;</li> <li>f. A Stormwater Management and Erosion Control Plan;</li> <li>g. Endangered species and archaeological / historical studies;</li> <li>h. Wetland and water body (coastal and inland) delineations;</li> <li>i. Environmental impact studies.</li> </ul> <b>(2.5.3.2B)</b>	<ul style="list-style-type: none"> <li>a. DRAINAGE ANALYSIS</li> <li>b. SHEET C5; NOTE 4</li> <li>c. SHEET C6</li> <li>d. SUPPLEMENTAL SUBMITTAL</li> <li>e. N/A</li> <li>f. SHEET D1 &amp; D4</li> <li>g. N/A</li> <li>h. N/A</li> <li>i. N/A</li> </ul>	
<input type="checkbox"/>	A document from each of the required private utility service providers indicating approval of the proposed site plan and indicating an ability to provide all required private utilities to the site. <b>(2.5.3.2D)</b>	TO BE PROVIDED	
<input checked="" type="checkbox"/>	A list of any required state and federal permit applications required for the project and the status of same. <b>(2.5.3.2E)</b>	COVER SHEET	

Applicant's Signature: \_\_\_\_\_ Date: January 14, 2018

Reviewed by: \_\_\_\_\_ Date Reviewed: \_\_\_\_\_

**FIFTH AMENDMENT TO DECLARATION OF CONDOMINIUM FOR  
30 MAPLEWOOD CONDOMINIUM  
30 MAPLEWOOD AVENUE, PORTSMOUTH, NH 03801**

**RECORD OF WITHDRAWAL OF LAND FROM CONDOMINIUM**

**NOW COMES 30 MAPLEWOOD LLC** a New Hampshire limited liability company with a mailing address of 36 Maplewood Avenue, Portsmouth, New Hampshire, Declarant of 30 Maplewood Condominium, WHO BY THESE PRESENTS, **AMENDS** the Declaration of Condominium dated July 15, 2015, and recorded in the Rockingham County Registry of Deeds on July 16, 2015, in Book 5636, Page 1930, as amended by the First Amendment recorded in said Registry on August 21, 2015 in Book 5647, Page 1038, and as further amended by the Second Amendment recorded in said Registry on January 29, 2016 in Book 5688, Page 2226, and as further amended by the Third Amendment recorded December 19, 2016 in said Registry in Book 5783, Page 2443, and as further amended by the Fourth Amendment recorded March 31, 2017 in said Registry in Book 5807, Page 2635 and being on land submitted to condominium unit ownership and shown as Exhibit A in said Declaration of Condominium and is depicted on Site and Floor Plan filed with the Declaration and recorded in said Registry as Plan #D-38936, the Amended Site Plan recorded in said Registry as Plan #39005, the Amended First Floor Plan recorded in said Registry as Plan #D-39300 and the Amended Floor Plans recorded in said Registry as Plan #D-40050.

**THE DECLARANT HEREBY WITHDRAWS FROM CONDOMINIUM OWNERSHIP THE LAND AS DESCRIBED IN THE FIRST AMENDMENT TO THE DECLARATION IN “EXHIBIT A-2, WITHDRAWABLE LAND”, ATTACHED HERETO AS EXHIBIT A.**

**The Withdrawn land is benefited by the following easements upon the Submitted land:**

1. An access easement in favor of the Withdrawn land from Bridge Street to the Withdrawn land over a 24 foot wide travel way from the curb cut serving both the Submitted land and the Withdrawn land as described in easements upon the Submitted land. The condition of this easement is that the owner of the Withdrawn parcel pay its prorata share of the upkeep of the common area parking;
2. An underground drainage easement from the Withdrawn land to a point in the above access easement as shown on the subdivision plan to be recorded herewith;



3. An easement in favor of the Withdrawn land for the use of the proposed dumpster on the Submitted land on the condition that the Withdrawn land pay its prorate share of the cost of use;
4. An underground electrical service access easement over the remaining Submitted land to an Eversource transformer as shown on the subdivision plan to be recorded herewith;
5. A construction easement to allow staging along the common border of the Withdrawn land and the remaining Submitted land to allow construction of a building on the Withdrawn land.

**The Withdrawn land is subject to the following easements:**

- A. A pedestrian easement from Deer Street running along the southeasterly bound of the VFW property shown on the subdivision plan to be recorded and the southwest façade of the building to be constructed on the Withdrawn land and extending to the remaining Submitted land.
- B. An underground utility access easement as shown on said subdivision plan being 5 feet in width, the center line of said easement running from Maplewood Avenue along the dividing line between the Withdrawn land and the remaining Submitted land extending to the transformer as shown on said subdivision plan;
- C. A pedestrian easement 5 feet+/- in width, the centerline of which runs from Maplewood Avenue between the Withdrawn land and the remaining Submitted land as shown on said subdivision plan.
- D. A potential no build area as shown on said plan and more fully described in Note 9 of said plan.

Both the Withdrawn land and the remaining Submitted land are burdened with mutual maintenance easements to allow for the maintenance and repair of the building facades which, upon construction of a building on the Withdrawn land, will lie adjacent to each other.

This Amendment is consistent with RSA 356-B:36 and the First Amendment to the Declaration.

IN WITNESS HEREOF, the Declarant, 30 Maplewood LLC has executed this Fifth Amendment to Declaration on this 15<sup>TH</sup> day of JUNE 2017.

**30 MAPLEWOOD LLC**

  
\_\_\_\_\_  
Stephen Kelm, Its Manager

STATE OF NEW HAMPSHIRE  
COUNTY OF ROCKINGHAM

The foregoing instrument was acknowledged before me this 15<sup>TH</sup> day of JUNE 2017 by Stephen Kelm, Manager of 30 Maplewood LLC as Declarant of 30 Maplewood Condominium, for the purposes herein contained.

  
\_\_\_\_\_  
GREGG W. ANNIS, Notary Public

My commission expires: SEPTEMBER 4, 2018



**EXHIBIT A**  
**WITHDRAWN LAND**

A certain tract of land with buildings and improvements thereon located in Portsmouth, Rockingham County, New Hampshire bounded and described as follows:

Beginning at a concrete bound on the southwesterly sideline of Maplewood Avenue, said point being southeasterly of the intersection of Deer Street and Maplewood Avenue;

Thence running along Maplewood Avenue S 21° 47' 03" E a distance of 138.36 feet to a point;

Thence turning and running S 45° 18' 15" W a distance of 126.59 feet to a point;

Thence turning and running N 44° 41' 45" W a distance of 68.47 feet to land now or formerly of the Emerson Hovey Post 168;

Thence turning and running along land of said Post N 48° 13' 15" E a distance of 36.34 feet to a point;

Thence turning and running along land of said Post N 43° 28' 02" W a distance of 68.20 feet to a point;

Thence turning and running along land of said Post S 46° 31' 15" W a distance of 4.30 feet to a point;

Thence turning and running along said Post N 43° 29' 45" W a distance of 23.84 feet to the southeasterly sideline of Deer Street;

Thence turning and running along Deer Street N 45° 37' 55" E a distance of 126.36 feet to a point;

Thence turning and running along the intersection of Deer Street and Maplewood Avenue on a curve to the right, with a radius of 22.00 feet, a delta angle of 112° 35' 04", and an arc length of 43.23 feet to a point at a concrete bound which is the point of beginning.

Having an area of 21,798 square feet, more or less.

Being a portion of the premises described in the deed from Martin Stein, Trustee of the 30 Maplewood Avenue Trust to 30 Maplewood, LLC dated March 29, 2010 and recorded in said Registry in Book 5099, Page 2424.

Return to:

---

---

---

### **EASEMENT DEED**

**KNOW ALL BY THESE PRESENTS**, That **30 MAPLEWOOD LLC**, a New Hampshire limited liability company c/o of Stephen Kelm, with a mailing address of 36 Maplewood Avenue, Portsmouth, County of Rockingham and State of New Hampshire,

GRANTS the following easements to the **CITY OF PORTSMOUTH**, a municipal corporation with a mailing address of 1 Junkins Avenue, Portsmouth, County of Rockingham and State of New Hampshire, upon its premises described as Lot 2 on an plan entitled "Easement and License Plan, Tax Map 125, Lots 1 & 2, Owner: 30 Maplewood, LLC" dated January \_\_, 2018 to be recorded herewith.

1. 30 Maplewood LLC grants to the City of Portsmouth a Pedestrian Easement as shown on said Plan and running from Deer Street to a public pedestrian easement along the southerly division line between Lot 1 and Lot 2 on said Plan, flaring out as it intersects with the public sidewalk of the City of Portsmouth along Maplewood Avenue.
2. 30 Maplewood LLC grants to the City of Portsmouth a Public Pedestrian Easement located between the face of the building to be constructed on Lot 2 and the public sidewalk along Maplewood Avenue and Deer Street as shown on said plan.

The purposed of these Pedestrian Easements is to allow pedestrian access to and along the building to be constructed.

Being a portion of the same premises conveyed to 30 Maplewood LLC by warranty deed of Martin G. Stein, Trustee of 30 Maplewood Avenue Trust dated March 29, 2010 and recorded in the Rockingham County Registry of Deeds in Book 5099, Page 2424.

This is not homestead property of the Grantor.

WITNESS the signature and acknowledgment of 30 Maplewood LLC for the purposes herein contained.

Signed this \_\_\_\_\_ day of \_\_\_\_\_, 2018.

**30 Maplewood LLC**

\_\_\_\_\_  
Its Manager,  
Stephen Kelm

State of New Hampshire  
County of Rockingham

The foregoing instrument was acknowledged before me this \_\_\_\_ day of \_\_\_\_\_, 2018,  
by Stephen Kelm, Manager of 30 Maplewood LLC, for the purposes herein contained.

\_\_\_\_\_  
Notary Public/Justice of Peace

## **LICENSE AGREEMENT FOR 46 MAPLEWOOD AVENUE LLC**

The **CITY OF PORTSMOUTH**, (hereinafter the “City”) a municipal corporation with a principal place of business at 1 Junkins Avenue, Portsmouth, New Hampshire, for good and valuable consideration as set forth herein, hereby grants this Revocable License to 30 Maplewood LLC (hereinafter the “Licensee”) a New Hampshire limited liability company with a principal place of business at 36 Maplewood Avenue, Portsmouth, New Hampshire for use in connection with the Licensee’s improvements to 46 – 64 Maplewood Avenue under its approved Easement and License Plan (hereinafter the “Project”), pursuant to the following terms and conditions:

1. **Area of License and Pedestrian Access:** The City authorizes Licensee, its successors and assigns to utilize the sidewalks and city land along portions of Deer Street and Maplewood Avenue that abuts the development as shown on the attached Easement and License Plan, Tax Map 125, Lots 1 & 2, Owner 30 Maplewood LLC, 30 – 64 Maplewood Avenue, City of Portsmouth, County of Rockingham, State of New Hampshire dated January \_\_ 2018 (and being Exhibit A hereto).

The City grants Licensee a license for two distinct license areas more fully described below. Each license area differs in use.

A. License Area #1: The Licensee is granted the right to run a 6-inch diameter perforated drain pipe under the City sidewalk abutting Lot 2 as shown on Exhibit A. The purpose of this drainpipe is to disburse roof rain water to feed the roots of the trees to be planted in the abutting City sidewalk, as shown on said Plan.

B. License Area #2: The Licensee is granted the right to surface a portion of the City sidewalk along Deer Street with smooth-faced cobblestones with a thermal finish, leading from the below surface garage of Licensee to Deer Street. The width of the cobbled surface will be twelve feet at the building entrance and flaring to eighteen feet at the City travelway as shown on said Plan. Licensee may use said travelway area for garage access.

2. **Indemnification:** Licensee agrees to indemnify and hold harmless the City of Portsmouth for any and all property damage, bodily injury or personal injury that arises as a result of its utilization of the Licensed Areas. This obligation survives termination or revocation of this Agreement.

3. **Insurance:** At all times Licensee shall maintain insurance for bodily injury and property damage in the amount of at least \$1,000,000.00 per occurrence. Licensee shall maintain a certificate of insurance on file with the City's Legal Department during the term of this Agreement.
4. **Maintenance of Area:** During the terms of this Agreement, Licensee will maintain the Licensed Areas in neat and orderly fashion and in accord with the CMMP. The Licensee shall secure the perimeter of the Licensed Area in accordance with its approved CMMP.
5. **Damage:** To the extent improvements to the public ways within the Licensed Areas are not already described in the approved site plan, Licensee agrees to take reasonable steps to remedy any damage to the Licensed Areas caused by the Licensee's activities.
6. **Compliance with Other Laws:** This Agreement does not relieve Licensee from compliance with any other local, state or federal laws or regulations or conditions imposed by any local board or the CMMP. Failure to abide by any local, state or federal laws or regulations may, at the City's discretion, result in revocation.
7. **Revocation:** The City may terminate this Agreement or any provision contained in this Agreement on five (5) business days advance written notice provided to Licensee if the public interest requires such termination.

Dated this \_\_\_\_\_ day of \_\_\_\_\_, 2018.

**30 Maplewood LLC**

\_\_\_\_\_  
Its Manager,  
Stephen Kelm

**City of Portsmouth**

\_\_\_\_\_  
John P. Bohenko, City Manager,  
Pursuant to vote of the City Council  
of \_\_\_\_\_, 2018

**30 MAPLEWOOD CONDOMINIUM  
30 MAPLEWOOD AVENUE, PORTSMOUTH, NH 03801**

**MUTUAL EASEMENTS AGREEMENT**

**NOW COMES 30 MAPLEWOOD LLC (“Thirty”)** a New Hampshire limited liability company with a mailing address of 36 Maplewood Avenue, Portsmouth, New Hampshire, and the **30 MAPLEWOOD CONDOMINIUM ASSOCIATION (“Association”)**, 36 Maplewood Avenue, Portsmouth, New Hampshire who for mutual consideration acknowledge the following:

**WHEREAS Thirty** is the owner of Lot 2 as shown on an Easement and License Plan, Tax Map 125, Lots 1 & 2 dated January 10, 2018; and

**WHEREAS the Association** is the owner of Lot 1 on said plan; and

**WHEREAS the Parties** have heretofore set forth mutual easements in the Fifth Amendment to the Declaration of Condominium for 30 Maplewood Condominium, Record of Withdrawal of Land from Condominium, recorded in the Rockingham County Registry of Deeds in Book 5835, Page 1026; now,

**THEREFORE the Parties** do grant each other certain cross easements as follows:

1. The **Association** grants to **Thirty** a certain no-build easement extending ten (10) feet from the southwest face of the building on Lot 2 perpendicular to the VFW building where the proposed building on Lot 2 faces the parking area of the Association adjacent. The condition of this easement is that the Association agrees not to construct a building within the easement area as shown on said Plan.
2. **Thirty** grants to the **Association** the use of a partial parking space measuring four (4) feet by nineteen (19) feet; said area to be used in conjunction with a partially relocated parking space designated LCA PS 18 on the Amended Condominium Site Plan recorded in the Rockingham County Registry of Deeds as Plan D-39005. Said easement area is also shown on the Easement and License Plan.



3. The **Association** grants to **Thirty** the right to tie into a surface drainage easement to be constructed by **Thirty** on Lot 1 as shown on said Easement and License Plan. As consideration for this easement, **Thirty** agrees to construct said drainage easement and to maintain said drainage easement in perpetuity.

IN WITNESS HEREOF, the Parties execute and acknowledge this Agreement on this \_\_\_\_ day of \_\_\_\_\_ 2018.

**30 MAPLEWOOD LLC**

\_\_\_\_\_  
Stephen Kelm, Its Manager

STATE OF NEW HAMPSHIRE  
COUNTY OF ROCKINGHAM

The foregoing instrument was acknowledged before me this \_\_\_\_ day of \_\_\_\_\_ 2018 by Stephen Kelm, Manager of 30 Maplewood LLC as Declarant of 30 Maplewood Condominium, for the purposes herein contained.

\_\_\_\_\_  
\_\_\_\_\_, Notary Public  
My commission expires:

**30 MAPLEWOOD CONDOMINIUM ASSOCIATION**

\_\_\_\_\_  
\_\_\_\_\_, Its President

STATE OF NEW HAMPSHIRE  
COUNTY OF ROCKINGHAM

The foregoing instrument was acknowledged before me this \_\_\_\_ day of \_\_\_\_\_ 2018 by \_\_\_\_\_, President of the 30 Maplewood Condominium Association, for the purposes herein contained.

\_\_\_\_\_  
\_\_\_\_\_, Notary Public  
My commission expires:

# 30 Maplewood Avenue Trust

c/o Presidential Estates

---

1020 Southern Artery · Quincy, Massachusetts 02169 · Tel. (617) 479-3555

October 24, 1994

Emerson Hovey VFW Post 168  
238 Deer Street  
Portsmouth, NH 03801

Attn: Richard Higgins

RE: 238 Deer Street- Understanding Regarding Parking

Dear Commander Higgins:

I am writing to confirm our understanding regarding the arrangements with regard to our property at 30 Maplewood Avenue and your property at 238 Deer Street.

As you know, our parking lot currently has two entrances. We plan to permanently close one. Nevertheless, we wish to confirm that we will continue to allow you to park on our property on the Bridge Street side of your building and to access this parking by driving through our lot. Additionally, we will continue to allow you to have access to the rear of your building for deliveries and maintenance. During non-business hours, we will also allow you to park on the rest of our parking lot, but only if parking spaces are available and not then being used by our Tenants.

In exchange for this, you will allow us to park on a portion of your property on the Maplewood Avenue side of your building, and will allow us to dig up and maintain planting beds on the Maplewood Avenue side of your building and the rear of your building.

We both agree that this arrangement is not intended to convey any property rights to each other. It is merely for the convenience of the parties and can be terminated by either party on 120 days' prior notice. Moreover, this agreement does not create any further responsibilities on the part of each party. For example, neither of us is required to provide snow plowing services on our property for the benefit of the other party, nor is either of us required to provide lighting or security within the parking areas which we are allowing the other one to use. We each agree to indemnify and hold the other harmless from all loss, cost, damage, suits, claims, including reasonable attorneys' fees, arising from any use of the other's parking area by us or anybody using the other's parking areas with our knowledge or consent. Of course, this indemnification will not shield either of us from our own gross negligence.

I am authorized to sign this agreement on behalf of the 30 Maplewood Avenue Trust. Please arrange for the enclosed photocopy to be signed on behalf of your organization by someone who is authorized to do so.

Very truly yours,



Martin G. Stein, Trustee of 30 Maplewood Avenue Trust, and not individually

The above terms are hereby agreed to:

Emerson Hovey VFW Post 168

BY: Richard Higgins Connors

Name:

Its:

Hereunto duly authorized

ACK079F8/dbw/eea

### **46 Maplewood Avenue :: Green Building Components**

Below are some of the unique products we have specified to be included in this development. In addition to these feature products, the building will benefit from energy efficient appliances, LED lighting, heating, and cooling systems.

### **Silva Cells by DeepRoot Green Infrastructures**

'DeepRoot Green Infrastructure develops solutions to enhance urban forests and surrounding watersheds in city streets, parking lots, campuses, and other heavily-paved areas. 'Silva Cell, our flagship product, is an underground framework for containing lightly compacted soil that supports large trees and absorbs runoff from rain, increasing air and water quality, reducing energy loads, mitigating heat island effect and nurturing trees for a long life in their communities'

### **TruGRAIN Wall and Decking Systems**

'TruGrain® made with Resysta® offers the warmth and feel of wood, but it also embodies the sustainability and wear-ability that natural hardwoods lack. TruGrain also stands apart from wood composites because it is a bio-based wood substitute.

TruGrain takes agricultural waste and transforms it into a durable building product with many applications. Approximately 25% (by weight) of the proprietary formula is rice husks, a rapidly renewable resource in great supply. Calcium carbonate and synthetic plastic polymer combined with the ARF at extremely high temperatures yield a product that can be formed to almost any shape or size. TruGrain qualifies for third party sustainability certifications based on its sustainable resource content and being 100% recyclable in the manufacturing process . TruGrain does not contain any wood and therefore does not contribute to deforestation.

### **Genest Architectural Masonry Products**

'Genest's superbly crafted finished concrete products deliver on what matters most: beautiful results that reflect a unique style and vision. From outdoor living spaces, downtown sidewalks, high profile commercial projects, sustainable and energy efficient wall systems, paving and retaining walls, Genest makes it all possible.'

Based in Sanford Maine, Genest products are locally sourced maintaining a low carbon footprint and therefore an environmentally conscious choice.

### **Marvin Integrity Windows and Doors**

'Integrity windows and doors are made with Ultrex®, a pultruded fiberglass we've patented that outperforms and outlasts vinyl, roll-form aluminum and other fiberglass composites. We use Ultrex and our proprietary pultrusion process to manufacture high-demand windows and doors that endure all elements without showing age or wear.'

Integrity products meet or exceed federal ENERGY STAR guidelines, reducing environmental impact and providing savings on heating and cooling bills over time.



19 December, 2017

**Trip Generation Calculation  
Site Redevelopment  
46 Maplewood Avenue  
Portsmouth, NH**

The purpose of this calculation is to identify the net change in vehicle trips expected to be generated by the site development at the 46 Maplewood Avenue. Currently the site is comprised of a parking lot with 40 parking spaces that will be replaced with the building.

The plan is to construct a 21 unit residential building with a 3,200 square foot restaurant, and 12,900 square feet of specialized retail space.

In developing the expected trips Ambit Engineering considered the standard trip generation rates and equations published in the Institute of Transportation Engineers (ITE) Trip Generation Manual, 9<sup>th</sup> Edition (2012). The land use category that best correlates with the existing use is Park and Ride (ITE Land Use Code 090). The land use category that best correlates with the proposed use is "Apartment" (ITE Land Use Code 220) and "Quality Restaurant" (ITE Land Use Code 931) and "Specialty Retail Center" (ITE Land Use Code (826). The trip rates, based upon the number of parking spaces, the number of apartments, and the area of the restaurant and retail are summarized below for the **Weekday AM and PM Peak Hour**:

Trip Generation Summary

Existing – AM Peak Hour

Parking (0.71 trips per space)	$0.71 \times 40 \text{ units} =$	28 trips
--------------------------------	----------------------------------	----------

Proposed – AM Peak Hour

Apartments (0.51 trips per dwelling unit)	$0.51 \times 21 \text{ units} =$	11 trips
Retail (6.84 trips per thousand sq. ft.)	$6.84 \times 12.9 \text{ k sq. ft.} =$	88 trips
Restaurant (0.81 trips per thousand sq. ft.)	<u><math>0.81 \times 3.2 \text{ k sq. ft.} =</math></u>	<u>3 trips</u>
Total		101 trips

Existing – AM Peak Hour

Parking (0.62 trips per space)

0.62 x 40 units =

25 trips

Proposed – AM Peak Hour

Apartments (0.62 trips per dwelling unit)

0.62 x 21 units = 13 trips

Retail (2.71 trips per thousand sq. ft.)

2.71 x 12.9 k sq. ft. = 35 trips

Restaurant (7.49 trips per thousand sq. ft.)

7.49 x 3.2 k sq. ft. = 24 trips

Total

72 trips

Trip Generation Impact

The increase anticipated with this project is 47 additional trip in the PM peak hour and 73 additional trips in the AM peak hour. Although there is an increase in anticipated traffic, it is does not detrimentally alter the traffic conditions. Deer Street is designed for uses such as this proposed project.

Please feel free to call if you have any questions or comments.

Sincerely,

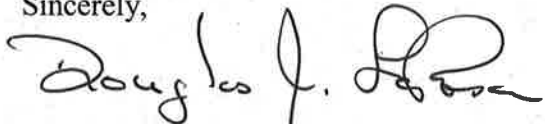

Douglas J. LaRosa, Project Engineer

Submission: City Site Plan Review Application Package

DRAINAGE ANALYSIS  
SITE DEVELOPMENT

MAP 125, LOT 2A  
46 Maplewood Avenue  
For  
30 Maplewood Avenue, LLC

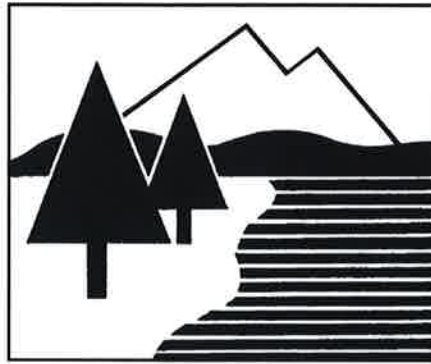

October, 2017

Revised: December, 2017

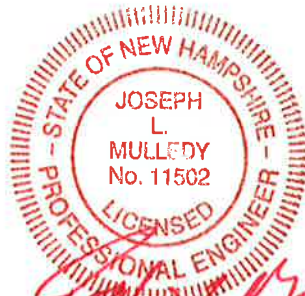

Ambit Engineering, Inc.

Civil Engineers and Land Surveyors  
200 Griffin Road, Unit 3  
Portsmouth, NH 03801  
Phone: 603.430.9282; Fax: 436.2315  
E-mail: [jlm@ambitengineering.com](mailto:jlm@ambitengineering.com)

## EXECUTIVE SUMMARY

This analysis is meant to be used by City officials, the developer, builders, earthwork contractors and other interested parties to better understand the assumptions and intent of the stormwater management system. This drainage analysis examines and compares the existing and proposed conditions stormwater drainage patterns for a Site Development at 46 Maplewood Avenue in the City of Portsmouth, at Assessor's Map 125, Lot 2A. The total lot size is 21,798 s.f. The point of analysis is a downstream manhole located on Deer Street (DMH 3540). The existing site is primarily impervious surface of pavement and buildings. The small areas of porous surfaces are either gravel or mulch.

The "existing" conditions site plan show the condition immediately before development (i.e., as it exists today). Runoff amounts from this existing state are a function of the land cover, vegetation and soils; together those factors produce what is known as the Curve Number. The "existing" or pre-developed curve number for the entire site (excluding offsite subcatchments) is 97. Typically, highly developed areas with lots of impervious area will have curve numbers approaching 90, whereas undisturbed or undeveloped areas can have curve numbers as low as 30 if the soils are well-drained and covered with forest. The proposed development's curve number increases slightly to 98 due to the increase in impervious surface (pavement and rooftop). However, because the increase in impervious surface is very small, post development peak runoff is unchanged. A Hancor "Water Quality Treatment Unit" is being provided within the parking lot along the Bridge Street entrance to the site. This unit is designed to divert low flows from up to the 2-Year Storm Event to provide treatment of surface runoff from the parking lot.

There is one design point on this parcel which is used to compare pre and post-developed runoff amounts. This is the drain manhole in Deer Street (DMH 3540). This design point is labeled DP1. However, the system downstream from this manhole has been modeled for analysis as well.

The 2, 10, 25 and 50 year, 24 hour storm events are used to compare the peak runoff amounts at the design point (DP 1).



## **METHODOLOGY**

This report uses the US Soil Conservation Service Method for prediction of storm water runoff. The SCS method is published in The National Engineering Handbook, Section 4 "Hydrology", in Technical Release No. 20, (TR-20) "Computer Program for Project Formulation Hydrology", and Technical Release-55 (TR-55) "Urban Hydrology for Small Watersheds". This report uses the HydroCAD program, written by Applied Microcomputer Systems, Chocorua, N.H., to apply these methods. Rainfall data are taken from the Extreme Precipitation Tables published by the Northeast Climate Center.

## **SITE SPECIFIC INFORMATION**

Located on Maplewood Avenue in Portsmouth, this site is currently developed and occupied by paved parking.

The existing site topography can be described as fairly flat that gently slopes from northwest to southeast away from Deer Street.

The majority of Soils on this site are of the "Urban land-Canton" complex. These soils can be described as being well-drained.

## **DRAINAGE ANALYSIS**

This drainage analysis consists of two sections, an analysis of the stormwater runoff from the site in the existing condition, and an analysis of the stormwater runoff from the same area with the proposed development. Areas and drainage information were taken from an existing conditions plan and site topographic map prepared by this office. Soils information was taken from the NRCS soils maps. Vegetative cover information was determined by on-site inspection.

### **Existing or Pre-Developed Site Runoff**

In order to study the site in greater detail and estimate peak stormwater runoff, it is necessary to divide the site into watershed subcatchments. There are 8 subcatchments that define the existing analysis. Their delineation is based on where their runoff discharges across property boundaries.

Subcatchment ES8: This subcatchment defines the runoff area from the sidewalk and roadway on the east side of the site along Maplewood Ave.

The following table summarizes the existing subcatchments. The total rainfall amounts for the 2, 10, 25 and 50 year storm are 3.00", 4.30", 5.20" and 5.70".

Table 1: Existing Watershed Subcatchment Runoff Results.

Subcatchment	Area Sf	Tc min.	CN	2 Year Peak cfs	10 Year Peak cfs	25 Year Peak cfs	50 Year Peak cfs
ES1	16,738	5	98	1.12	1.62	1.97	2.16
ES2	22,558	5	97	1.49	2.17	2.64	2.89
ES3	10,622	5	97	0.70	1.02	1.24	1.36
ES4	4,188	5	98	0.28	0.41	0.49	0.54
ES5	20,107	5	97	1.33	1.93	2.35	2.58
ES6	11,261	5	97	0.74	1.08	1.32	1.44
ES7	5,094	5	97	0.34	0.49	0.60	0.65
ES8	7,456	5	97	0.49	0.72	0.87	0.96
Totals	98,024	----	97	----	----	----	----

See "Plan of Proposed Subcatchments" – W1.

Proposed or Post-Developed Site Runoff

There are eleven subcatchments in the proposed analysis. The same Design Point (DP 1) is utilized for the developed condition. All eleven subcatchments flow to the same Design Point (DP 1).

The following is a description of the various subcatchments:

Subcatchment PS6: This subcatchment defines the runoff area from the sidewalk and roadway in the northeast corner of the site near Deer Street and Maplewood Ave.

Subcatchment PS7: This subcatchment defines the runoff area from the sidewalk and roadway on the east side of the site along Maplewood Ave.

Subcatchment PS8: This subcatchment defines the runoff area from the sidewalk and roadway on the east side of the site along Maplewood Ave.

Table 2: Proposed or Developed Conditions

Subcatchment	Area Sf	Tc min *	Weighted CN	2 Year Peak cfs	10 Year Peak cfs	25 Year Peak cfs	50 Year Peak cfs
PS1	16,738	5	98	1.12	1.62	1.97	2.16
PS2	7,730	5	97	0.51	0.74	0.90	0.99
PS2a	2,509	5	98	0.17	0.24	0.30	0.32
PS2b	5,028	5	98	0.34	0.49	0.59	0.65
PS3	8,542	5	98	0.57	0.83	1.00	1.10
PS3a	4,848	5	98	0.33	0.47	0.57	0.63
PS4	4,188	5	98	0.28	0.41	0.49	0.54
PS5	20,107	5	97	1.33	1.93	2.35	2.58
PS6	12,323	5	98	0.83	1.20	1.45	1.59
PS7	8,519	5	98	0.57	0.83	1.00	1.10
PS8	7,456	5	97	0.49	0.72	0.87	0.96
Totals	97,988*						

See "Plan of Proposed Subcatchments" – W2.

## **Conclusion**

The new development can be built without increasing the risk of flooding or erosion onto neighboring properties. Given the results of the preceding analysis and compliance with known city requirements, it is our opinion that this project will not have downstream impact to the existing storm drain system.

## **INSPECTION & MAINTENANCE PLAN**

FOR

**30 Maplewood Avenue, LLC**

**46 Maplewood Avenue  
Portsmouth, NH**

### **Introduction**

The intent of this plan is to provide the developers of the proposed 46 Maplewood Avenue (herein referred to as Developer), with a list of procedures that document the inspection and maintenance requirements of the stormwater management system for this development.

The following inspection and maintenance program is necessary to keep the stormwater management system functioning properly. These measures will also help minimize potential environmental impacts. By following the enclosed procedures, the Developer will be able to maintain the functional design of the stormwater management system and maximize its ability to remove sediment and other contaminants from site generated stormwater runoff. By installing and maintaining the drainage as shown on the approved site plan, the Developer will be able to maximize the system's ability to control the volume of runoff and remove sediment from site generated stormwater runoff.

### **Annual Report**

The Developer shall prepare an annual Inspection & Maintenance Report. The report shall include a summary of the system's maintenance and repair by transmission of the Inspection & Maintenance Log and other information as required. A copy of the report shall be delivered annually to the City of Portsmouth Code Enforcement Officer, if required.

### **Inspection & Maintenance Checklist/Log**

The following pages contain a Stormwater Management System Inspection & Maintenance Checklist and a blank copy of the Stormwater Management System Inspection & Maintenance Log. These forms are provided to Developer as a guideline for performing the inspection and maintenance of the Stormwater Management System. This is a guideline and should be periodically reviewed for conformance with current practice and standards.

## *STORMWATER MANAGEMENT SYSTEM COMPONENTS*

The Stormwater Management System is designed to mitigate both the quantity and quality of site-generated stormwater runoff. As a result, the design includes the following elements:

### **Non-Structural BMP's**

Non-Structural best management practices (BMP's) include temporary and permanent measures that typically require less labor and capital inputs and are intended to provide protection against erosion of soils. Examples of non-structural BMP's on this project include but are not limited to: Temporary and permanent mulching, temporary and permanent grass cover, trees, shrubs and ground covers, miscellaneous landscape plantings, dust control, tree protection, topsoiling, sediment barriers, temporary storm drain inlet protection, and a stabilized construction entrance.

### **Structural BMP's**

Structural BMP's are more labor and capital intensive structures or installations that require more specialized personnel to install. Examples on this project include but are not limited to: Storm drains and catch basins, vegetated swales, land grading and slope protection.

### **Inspection and Maintenance Requirements**

The following summarizes the inspection and maintenance requirements for the various BMP's that may be found on this project. In general, during construction and until the threat of erosion is minimal, rain events of 0.25" or more shall trigger close inspections of all related sediment and erosion control measures. It is only after construction is complete and the site is stable (safe from erosion) that larger rain events will trigger inspections (see attached Inspection & Maintenance Form).

1. **Seeded areas:** After each rain event of 0.5" or more during a 24 hour period, inspect newly seeded areas for signs of disturbance, such as erosion or lost mulch. If damaged areas are discovered, immediately repair the damage. Repairs may include adding new topsoil, lime, seed, fertilizer and mulch, or may simply require the addition of more mulch. If mulch is constantly being blown away or washed away, then it shall be anchored with jute mesh. Continue inspections until grass growth is permanently established and threats of erosion have ceased.
2. **Other Plantings:** Other planting and landscaping (trees, shrubs,) shall be monitored bi-monthly during the first year to insure viability and vigorous growth. Replace dead or dying vegetation with new stock and make adjustments to the conditions that caused the dead or dying vegetation. During dryer times of the year, provide weekly watering or irrigation during the establishment period of the first year. Make the necessary adjustments to insure long-term health of the vegetated covers, i.e. provide more permanent mulch or compost or other means of protection.
3. **Storm Drain, Trench Drain Inlets/Outlets:** Monitor drain inlets and outlet aprons for excessive accumulation of sediments or missing stone/riprap. Remove sediments as required to maintain filtering capabilities of the stone—replace missing riprap.

4. **Stabilized Construction Entrance:** Monitor for signs of excessive clogging and tracking of mud onto the paved roadway. If necessary, replace the entire structure with new, clean stone, and remove tracked sediments from road surface.
5. **Dust Control:** Monitor fugitive dust and if evident, apply water to graveled surfaces or mulch and water to exposed, droughty soils.
6. **Hancor Water Quality Unit:** Remove sediment the more frequent of every six months or when sediment has reached 25% of the diameter of the structure. Furthermore, the system may need cleaning in the event a spill of foreign substance enters the unit.

### **Invasive Species**

Monitor site for signs of invasive species growth. If caught earlier enough, their eradication is much easier. The most likely places where invasions start are in wetter, disturbed soils or detention ponds. Species such as phragmites and purple loose-strife are common invaders in these wetter areas. If they are found then the Developer shall contact a wetlands scientist with experience in invasive species control to implement a plan of action to eradicate the invaders. Measures that do not require the application of chemical herbicides should be the first line of defense.

## Stormwater Management System

### Inspection & Maintenance Checklist for Post Construction Condition—for 30 Maplewood Avenue, LLC, 46 Maplewood Ave., Portsmouth, NH

<b>BMP/System Component</b>	<b>Minimum Inspection Frequency</b>	<b>Minimum Inspection Requirements</b>	<b>Maintenance/Cleanout Threshold</b>
<b>Ditches and Swales</b>	<i>After significant rain events (&gt;2"/day)</i>	Check for erosion, trash or sediment accumulations.	Repair eroded areas with new sod; remove trash/sediments and maintain grass at 4"~6".
<b>Seeded Slopes, Lawns and other Landscaped Areas</b>	<i>After significant rain events (&gt;2"/day); and/or monthly.</i>	Check for erosion or dead grass growth. Check plantings for vitality or droughty soils.	Repair or re-seed & mulch as required; replant dead or dying shrubs & trees.
<b>Hancor Water Quality Unit</b>	<i>Twice Yearly</i>	Check for blocked baffles and inlets	Clean any accumulated sediment at the time of inspection
<b>Closed Drainage System</b>			
Catch Basins and Outlet Control Structures	<i>Twice Yearly</i>	Check for sediment accumulation and debris	Remove debris and sediment when they accumulate
Trench Drain	<i>Every other Month</i>	Check for sediment accumulation Check for floatable contaminants	Remove sediments when they accumulate
Drainage Pipes	<i>Yearly</i>	Check for sediment clogging, or soiled runoff.	≥ Clean entire drainage system and remove all sediments if discovered in piping.
<b>Annual Report</b>	<i>Yearly</i>	Prepare Annual Report, including all Inspection & Maintenance Logs. Provide to C.E.O. if required).	N/A



**Stormwater Management System Maintenance Summary**

**Inspection & Maintenance Log—for 30 Maplewood Avenue, LLC, 46 Maplewood Ave., Portsmouth, NH**

<b>BMP/System Component</b>	<b>Date Inspected</b>	<b>Inspector</b>	<b>Problems Noted, Required Maintenance <i>(List Items/Comments)</i></b>	<b>Date of Maintenance</b>	<b>Performed By</b>



# SILVA CELL OPERATIONS AND MAINTENANCE MANUAL



## TABLE OF CONTENTS

1.0 Acknowledgments	3
2.0 Introduction	3
2.1 Purpose	3
2.2 Permit Requirements	4
2.3 How to Use this Manual	4
2.4 Definitions	4
3.0 Maintaining Silva Cells	4
3.1 Key Component Design Function and Maintenance Considerations	4
3.1.1 Inlet system	4
3.1.2 Distribution Pipe	5
3.1.3 Irrigation Systems	5
3.1.4 Silva Cell Modular Units	5
3.1.5 Soil Media	5
3.1.6 Underdrain Pipe and Flow Control Devices	5
3.1.7 Trees / Vegetation	6
3.1.8 Surface Treatment	6
3.2 Maintenance Guidelines	6
3.3 Equipment and Materials	10
3.4 Skills and Staffing	10
4.0 Repairing Silva Cells	11
5.0 Programmatic and Administrative Guidance	11
5.1 Regulatory Requirements for LID BMP Maintenance Programs	11
5.2 Tools for Implementing an LID Maintenance Program	11
6.0 Additional Resources	11
7.0 References	12
Consultant Team	15

## LIST OF TABLES

Table 1: Silva Cell Maintenance Guidelines	7
Table 2: Skills and Staffing Table	10

## LIST OF APPENDICES

Appendix A DeepRoot Warranty	13
Appendix B City of Toronto, ON; Tree Planting Solutions in Hard Boulevard Surfaces; Best Practices Manual	14
Appendix C Protection and Maintenance	29

## 1.0 Acknowledgments

There are many dedicated, brilliant people working on the challenge of creating healthier, more sustainable, and more efficient cities. We believe the most successful of these places will be those grounded in the principle that nature and engineering can coexist successfully. Soil, urban trees, and sustainable stormwater management are at the core of this effort. We wish to express our tremendous appreciation and gratitude to the many researchers and practitioners whose work we have relied on to inform the guidelines contained in this manual. Thank you to the following people for their specific contributions.

### Authors:

DeepRoot Green Infrastructure, LLC  
John Erickson, HDR Engineering  
Robin Kirschbaum, HDR Engineering

### Technical Review Committee:

Tim O'Hare, Tim O'Hare and Associates  
Jonathan Page, North Carolina State University  
(Engineering Intern to Dr. Bill Hunt)  
Dr. Jessica Sanders, Casey Trees  
Nathalie Shanstrom, Kestrel Design Group  
James Urban, Urban Trees + Soils

## 2.0 Introduction

Silva Cells are a modular suspended pavement system that provides soil volume to support large tree growth and provides stormwater management through interception, storage, evapotranspiration, and pollutant uptake. When filled with soil media of suitable depth and quality, Silva Cells also promote filtration of stormwater runoff through the soil media and infiltration of treated runoff into native site soils, making them a versatile Low Impact Development (LID) Best Management Practice (BMP).

In March 2013, the Washington State Department of Ecology approved Silva Cells as functionally equivalent to bioretention (Ecology 2013a). This approval allows designers in Washington State to design Silva Cells to

fully or partially satisfy minimum stormwater requirements for LID, water quality treatment, and flow control in accordance with the National Pollutant Discharge Elimination System (NPDES) Municipal Separated Storm Sewer System (MS4) permit (NPDES stormwater permit). Similar approvals are in place in Montgomery County, Maryland; St. Louis, Missouri; Calgary, Alberta; and North Vancouver, British Columbia. Additional approvals are currently pending in other areas across the United States and Canada as of the date of this manual.

When Silva Cells are installed as part of a permanent stormwater management system to meet stormwater permit requirements, they should be maintained as required by the local jurisdiction for maintenance of stormwater and LID BMPs.

The remainder of this section discusses the purpose of this document, applicable permit requirements, how this manual is intended to be used, and important definitions. Section 3 presents key maintenance considerations, maintenance guidelines, equipment and materials lists, and skills and staffing needs to accomplish the recommended maintenance. Section 4 discusses the repair of Silva Cell facilities. Section 5 discusses programmatic and administrative guidance, while Section 6 provides a list of additional resources relating to LID BMP design, inspection, operation, and maintenance and Section 7 provides a list of additional resources with relevant information on stormwater and LID BMP maintenance.

### 2.1 Purpose

This document provides guidance to assist owners and operators of Silva Cell facilities with planning and implementation of maintenance to promote long-term system performance in accordance with the design intent. These recommendations should be considered as general guidelines, not requirements, and they should be reviewed and adapted as appropriate to develop site-specific maintenance plans based on the specific design configuration of a given site.

## 2.2 Permit Requirements

Silva Cells may be designed and installed as LID BMPs that fully or partially satisfy applicable soil and/or stormwater requirements for new or redevelopment projects. Check the local permit requirements to determine whether such requirements apply to your project.

While Silva Cells can be designed as LID BMPs, they can also be used to promote large, healthy trees in dense urban environments, without the intent of formally managing stormwater runoff. In such cases, stormwater permit requirements would not apply.

## 2.3 How to Use this Manual

Operations and maintenance guidelines are provided in Section 3.0, organized in three subsections, as follows:

- **Subsection 3.1 Key Maintenance Considerations** - Provides details regarding maintenance activities that should be considered to maintain function of the facility.
- **Subsection 3.2 Key Operations to Preserve Facility Function** - Discusses the functions of the BMP that need to be preserved to maintain the intended performance.
- **Subsection 3.3 Maintenance Guidelines** - Provides information that can be used to develop a site specific maintenance plan.

Successful use of this manual requires understanding of the design intent, site and as-built conditions, and knowledge of applicable permit requirements (Section 2.2).

## 2.4 Definitions

Definitions for important terms used throughout this manual are as follows:

- **Best management practices (BMPs)** - Activities, practices, procedures, structural features, or products that are designed to reduce the risk of causing adverse impacts to downstream water bodies.
- **Drawdown Time** - The time it takes water from a given runoff event to completely drain through an infiltration BMP, typically measured from the end of the event to the time the water level in the system returns to baseflow conditions.
- **Infiltration** – Percolation of stormwater runoff into soil media or native site soils.

- **Low Impact Development (LID)** - A development approach that manages stormwater by working with nature and the existing site conditions in a manner that will reduce or prevent adverse impacts to the site or downstream environment.
- **Macropores** – Large, free-draining soil pores, oftentimes found between aggregates or near tree roots.

## 3.0 Maintaining Silva Cells

This section identifies key component design functions and maintenance considerations, provides guidance on inspection and maintenance activities and recommended frequencies, lists needed equipment and materials, and discusses skills and staff needed to perform the recommended maintenance.

### 3.1 Key Component Design Function and Maintenance Considerations

Key components of the Silva Cell system include the inlet structures, distribution pipes, the modular Silva Cell units and frames, fill soils, underdrain pipe, flow control structures, trees/vegetation, and surface treatments. Intended general design functions and maintenance considerations for each of these key components are discussed below.

#### 3.1.1 Inlet system

Silva Cell inlet systems can be designed to allow stormwater runoff to flow into the facility in a number of ways. Water can sheet flow from adjacent hardened surfaces, infiltrate via overlying or adjacent permeable surfaces, flow through curb cuts, or be piped from a catch basin, roof drains, or yard drains.

However the inlet system(s) are configured, they must be properly sized and maintained to allow stormwater runoff from the intended contributing drainage area to enter the facility. Key maintenance considerations include providing pre-treatment through temporary erosion and sedimentation control measures in the tributary drainage basin during construction and long-term pre-treatment through stabilization of open soil areas in the tributary basin with plants or mulch and maintenance of inlet capacity by removing sediment, trash, and debris from inlets and the contributing drainage area.

### 3.1.2 Distribution Pipe

Some installations may include a distribution pipe to distribute inflows across the surface of the facility. Distribution pipes are typically 4- to 8-inch-diameter (100- to 200-millimeter-diameter) perforated or slotted pipes installed on top of or within the soil media. Maintenance activities should preserve the ability of the pipe to distribute the water effectively by removing clogs and repairing or replacing cracked or broken pipes as needed.

### 3.1.3 Irrigation Systems

If the Silva Cells have been designed to include irrigation, follow the manufacturer instructions for operating and maintaining your chosen irrigation system. Also see the section above (3.1.2) if the irrigation system is passive and includes distribution pipes.

### 3.1.4 Silva Cell Modular Units

Silva Cell modular units are made from fiberglass-reinforced, chemically-coupled, impact-modified polypropylene with galvanized steel tubes. DeepRoot provides a 20-year warranty for the Silva Cell product, which is included for reference in Appendix A. Each module provides a 92% void volume, which is backfilled with a specified type and depth of soil media (Section 3.1.5) to support tree growth and promote stormwater management.

When used in a typical pedestrian application, the Silva Cell system has an estimated design life of approximately 100 years (DeepRoot 2014). The units themselves are not expected to require maintenance within that design life duration when properly designed and installed.

### 3.1.5 Soil Media

The soil media filled within the Silva Cell units (Section 3.1.4) performs critical functions of supporting tree growth and managing stormwater runoff. Organic matter in the soil media is important for both of these functions; because it helps trees build soil structure, provides a nutrient reservoir, and increases soil water holding capacity. In order to preserve a healthy balance of soil organic matter and soil biology, excess soil compaction must be prevented and proper drainage through the system must be maintained.

Silva Cells protect soils under pavement from excessive compaction by providing a post and beam structure that supports the pavement, allowing the soil media backfill to be lightly compacted. The lightly compacted soil media creates a healthy rooting environment for trees, which deliver increasing amounts of organic content to the soil system as the roots grow and decay. Stormwater inputs also deliver nutrients, such as nitrogen and phosphorus, helping to maintain soil organic matter over time.

Routine maintenance of the soil media is generally not needed provided the installation process of the cell and soil has been carried out correctly and the inlet (Section 3.1.1) and distribution (Section 3.1.2) systems are properly designed, installed, and maintained.

### 3.1.6 Underdrain Pipe and Flow Control Devices

Silva Cells may include underdrains when infiltration of treated stormwater runoff into native soil is not feasible or not desirable. Underdrains may be located at the bottom of the facility, or may be elevated to promote nitrogen removal and peak flow detention, depending on the design intent.

Typically, underdrain systems consist of 6- or 8-inch-diameter (100- to 200-millimeter-diameter) perforated or slotted pipe. The pipe may be installed in an aggregate filter blanket layer or may be wrapped with a geotextile liner for separation. Proper design and specification of the aggregate filter blanket or geotextile liner is critical to minimizing or preventing fines from the soil media or the native site soils from clogging the pipe.

Some underdrains may be designed with flow control devices (e.g., orifices or upturned elbows) to enhance nitrogen removal, detain peak flows, increase infiltration, or some combination thereof. These flow control devices should be maintained to prevent clogging and allow treated flows to discharge to the downstream conveyance system or receiving water as intended by design.

### 3.1.7 Trees / Vegetation

Silva Cells fundamentally promote tree growth, and are typically designed with one or more trees that are planted either in the facility or next to the facility in a way that allows the roots to grow into the soil media. Properly designed Silva Cells provide the needed soil volume and quality, water flow, and air flow to allow the trees to reach their true mature size.

As healthy trees grow, their canopies provide increasing capacity over time for interception, storage, and evapotranspiration. As the roots grow, they increase the trees' ability to uptake stormwater and associated pollutants and enhance infiltration by maintaining macropores in the soil column. Maintaining the trees as part of the Silva Cell system is therefore important to the overall performance of the facility over time. See Table 1 for recommended maintenance activities and schedule.

Trees and vegetation adapted to site conditions, such as climate, hydrology, and soil type, should be selected wherever possible to reduce chemical inputs and reduce or eliminate the need for watering. Proper design, installation, and maintenance of the inlet system (Section 3.1.2) and distribution system (Section 3.1.3) are also important to maintaining trees and vegetation properly watered. Similarly, proper design, installation, and maintenance of the underdrain pipe and flow control devices are important to maintaining desired watering regimes and draw-down rates.

### 3.1.8 Surface Treatment

Silva Cells can be designed to provide structural support for a variety of surface treatment types, including hard surfaces (e.g., permeable or impermeable asphalt, concrete, pavers, etc.) or natural surfaces (e.g., soil, lawn, vegetation). Surface treatments should be maintained in accordance with manufacturer recommendations and local jurisdiction requirements (i.e., pertaining to sidewalks, roadways, etc.), as applicable.

### 3.2 Maintenance Guidelines

The following table provides a breakdown of recommended routine inspection and maintenance activities and frequencies, conditions that trigger non-routine maintenance, and the associated recommended non-routine (triggered) maintenance activities for key Silva Cell components.

Table 1: Silva Cell Maintenance Guidelines

Component	Recommended Frequency		Inspection Activity	Condition when Maintenance is Triggered	Recommended Maintenance Actions
	Inspection	Routine Maintenance			
<b>Silva Cell Units</b>					
Frames (or base and posts) and Deck	As needed	None	Not Applicable	Facility shows signs of damage from external source (i.e., excessive loading from the surface, nearby construction, or similar)	Repair damaged component (refer to the Protection and Maintenance section of the Silva Cell Operations Manual included in Appendix B, pages 9-11).
Tree Opening	Spring, Fall, and after major storms	As needed	Check for clogging, standing water, sediment, trash, and debris	Evidence of clogging, standing water, accumulation of sediment, debris, or trash	As needed.
<b>Inlets/Outlets/Pipes</b>					
Inlet/outlet structures	Annually	After major storms	Check that the structures are operating properly	Water is not being directed properly to or out of the Silva Cell facility	Remove any blockages and clean pipe as needed.
Energy dissipation component at inlet (if applicable)	Annually	After major storms	Check that the energy dissipation is working correctly	Where applicable – Energy dissipation (i.e., splash block, rock, or cobbles) is removed or missing and concentrated flows are being directed into the facility improperly	Replace or restore the energy dissipation component of the facility to the original design.
Flow restrictor (if applicable)	Annually	After major storms	Check that the flow restrictor is operating properly	Water is not passing through the flow restrictor per the design flow rate	Remove material causing the blockage and repair component as needed.
Distribution pipes	Annually	Annually	Check that the distribution pipes are allowing water to distribute properly	Water is not being distributed within the facility per design	Remove blockages from pipes (e.g., jet clean, rotary cut roots/debris).
Underdrain pipes	Annually	Annually	Check that the underdrain pipes are	Water is not being drained through the underdrain pipes per design	Remove blockages from pipes (e.g., jet clean, rotary cut roots/debris).



Component	Recommended Frequency		Inspection Activity	Condition when Maintenance is Triggered	Recommended Maintenance Actions
	Inspection	Routine Maintenance			
Trees/Vegetation					
Tree	Biannually	As needed	Check need for pruning	Tree requires pruning for safety reasons, to promote healthy growth or to prevent the tree from growing in an undesirable manner.	Prune tree as needed for safety to promote healthy growth and to avoid conflicts with adjacent features (i.e., power lines, clearances from buildings or sidewalk, or similar). Pruning should be performed by a landscape professional that has experience pruning trees and per the guidance of an arborist certified by the International Society of Arboriculture.
	Spring, Fall, and after major storms	As needed	Check tree safety	Signs of potential danger include broken, dead, or hanging branches, cracks, fungi, cavities, weak trunk or branch unions	Remove components of the facility above the frames and decks in a manner that minimizes damage to the facility. Use HydroVac and hand tools to remove soil if soil removal is needed. Cut and remove roots as directed by an arborist. Do not cut or damage frames. Install new tree and Silva Cell components as needed to restore the facility to its designed configuration.
	Spring and Fall	As needed	Check tree health	Check tree for mower and weed whip damage, vandal damage, and animal damage. Inspect leaves, branches, crown and trunk for signs of insect or disease problems	Diagnose cause of problem: e.g. mower and weed whip damage, vandal damage, animal damage, over- or under-watering, pest or disease, soil problems, etc., and remedy.
	Every 4-5 years	As needed	Check for girdling roots	Girdling roots are found	Remove girdling roots.
	Annually	As needed	Check for soil or mulch on root collar	There is soil or mulch on the root collar	Clean soil or mulch off root collar until the first set of roots is found, take care not to harm roots.
	Annually	As needed	Check safety	Tree is dying, dead, diseased, or has become a safety hazard	Remove components of the facility above the frames and decks in a manner that minimized damage to the facility. Use HydroVac and hand tools to remove soil. Cut and remove roots as directed by an arborist. Do not cut or damage frames (or base and posts). Install new tree and Silva Cell components as needed to restore the facility to its designed configuration. Refer to the Protection and Maintenance section of the Silva Cell Operations Manual included in Appendix B.

Component	Recommended Frequency		Inspection Activity	Condition when Maintenance is Triggered	Recommended Maintenance Actions
	Inspection	Routine Maintenance			
<b>Tree</b>					
Vegetation	Biannually	As needed	Check tree health	Dying, dead, or unhealthy plants	Remove and replace dying, dead or unhealthy plants.
Weeds	Monthly	Monthly	Check for weeds	Weeds present in the facility	Remove weeds as necessary. Noxious weeds should be removed in accordance with local standards. Avoid using herbicides and pesticides in an effort to protect water quality.
Mulch	Monthly	After weeding	Check mulch coverage	Mulch layer has bare spots or a depth less than two inches (50 mm).	Cover bare spots and replenish mulch as required.
Watering		As needed	Not applicable	Tree/vegetation shows signs of being deprived of water or watering is anticipated during prolonged dry periods	Water frequency will vary depending on species, climate, and site conditions. Water appropriately to maintain a health of the tree or vegetation. Ensure water is reaching the entire soil column and perimeter, not just the tree opening.
<b>Pest Control</b>					
Nuisance Animals	Biannually	As needed	Check for signs of damage from animals	Damage or erosion caused by animals	Remove/reduce the item that is attracting the nuisance animals. Consider placing decoy predator species or pet waste bag stations to promote responsible activities.
Insects	Biannually or as needed	As needed	Check the presence of insects and or insect nests	Tree/vegetation shows signs of wilting, chewing of bark, spotting, or other indicators appropriate for the region.	Remove diseased or dead plants. Remove or reduce the source attracting the insects if possible. Follow the pest management procedures appropriate for the region.
<b>Surface Treatment</b>					
Hard Surfaces (i.e., permeable or impermeable concrete, asphalt, pavers, or grid systems)	Annually	As needed	See applicable manufacturer recommendations.		
Permeable Surfaces (i.e., vegetated areas)					

### 3.3 Equipment and Materials

The text box to the right provides a list of equipment and materials that may be needed to perform maintenance and inspection activities. The list should be reviewed and approved by the Silva Cell owner or operator and should be modified as appropriate for the specific installation. For instance, if the installation does not have a planter strip area, weeding equipment may not be needed. Similarly, if underdrains are not included, vactor, water jets, and pressure washing equipment may not be needed, etc.

### 3.4 Skills and Staffing

The skills and staff required to inspect and maintain Silva Cells will vary depending on the size of the installation, complexity of the system, surface treatment, and site constraints. Routine maintenance and inspection activities for the above-ground features will generally be similar to that of a street tree, planter strip, or sidewalk. Routine maintenance for the below-ground features will generally be similar to that of an underdrain or footing drain system.

The Table 2 summarizes the staffing resources that may be required for routine maintenance and inspection activities:

- **Safety Equipment** – As appropriate for the site (i.e., high visibility vest, gloves, long pants, boots, traffic control equipment, etc.)
- **Inspection Equipment**
  - Camera
  - Tape measure
  - Manhole key and lifter to open manhole, cleanout, or inspection port lids
  - Flashlight
  - Field report sheet
  - Inspection records and photos from previous inspections
  - As-built information
  - Manufacturers’ product information
  - Method of inspecting pipes and structure without entering them (i.e., camera or mirror on an extendable pole)
  - Equipment to measure drawdown time (i.e., stopwatch, measuring stick, water source, and hose)
- **Maintenance Equipment**
  - Broom, rake, and shovel
  - Weeding equipment
  - Bucket, wheelbarrow, garbage/leaf bags, and tarp
  - Tree trimming and pruning equipment
  - Hand tools
  - Plumbing snake
  - Vactor truck
  - Water jet
  - Pressure washer
- **Maintenance Material**
  - Pipe repair material
  - Replacement pipe material per the original design
  - Replacement surface material (i.e., pavers, asphalt, concrete, or natural material)

*Equipment and materials that may be needed to perform typical maintenance and inspection activities. Adapted from the Western Washington Low Impact Development (LID) Operation and Maintenance (O&M) Guidance Document (Ecology 2013b).*

Table 2: Skills and Staffing Table

Maintenance Activity	Staff Skills
Landscaping	Staff must have appropriate landscaping skills, including plant care, watering, and weeding, based on the trees/vegetation present; staff must have the ability to identify plants, weeds, and invasive weed species and have knowledge of the timing of weed seeding and growing periods.
Pruning and tree care	Staff conducting pruning and tree care activities should be a certified arborist or have equivalent training.
Pest Management	Staff conducting pest management activities must be able to identify pests applicable to the region and be familiar with methods to address those issues.
Erosion Control	Staff must have general knowledge of identifying sources of erosion, prevention methods, and removal methods.
Drainage System Maintenance	Staff inspecting drainage system must have general knowledge of the drainage system components included in the facility, specific knowledge of how the facility was built and its intended to function, and maintenance history.  Staff performing maintenance activities must be trained to operate the specialized equipment to conduct those activities (i.e., jet cleaning, root cutting, vactoring, CCTV inspection).

#### 4.0 Repairing Silva Cells

As the Silva Cell is a system that interacts with other infrastructure, repairs to adjacent elements, such as paving surfaces or utilities and services, must be undertaken with an understanding of the site-specific installation. Repairs to all system components and adjacent or nearby elements should be done per local guidelines and individual manufacturer directions, as applicable.

Each Silva Cell stack is independent of the Silva Cell stack adjacent to it. Therefore, if an individual stack is disturbed, the entire system is generally not expected to be compromised.

Examples of repair processes are provided in the Tree Planting Solutions for Hard Boulevard Surfaces Best Practices Manual, included in Appendix B. This manual documents two demonstration projects conducted by the City of Toronto, in which they field-tested a water main break scenario and a gas lateral and riser installed through Silva Cells. In both cases, the Silva Cells were found to pose no significant hindrance to their utility work.

Section IV of the Silva Cell Operations Manual (DeepRoot 2011), included in Appendix C, provides general information on how to protect installed Silva Cell systems, manage utilities in the vicinity of installed systems, repair or replace overlying pavement, and remove or replace Silva Cells and trees as needed.

#### 5.0 Programmatic and Administrative Guidance

This section discusses regulatory requirements for LID BMP maintenance (if applicable) and the available programs and tools to help with implementation.

##### 5.1 Regulatory Requirements for LID BMP Maintenance Programs

As discussed above, this manual provides general maintenance guidelines that can be adapted to site specific maintenance plans based on given site conditions. If Silva Cells are installed as part of a permanent stormwater management plan to

meet minimum stormwater requirements for new or redevelopment, local requirements for maintaining LID BMPs would apply. Consult the local standards and requirements to determine the maintenance requirements that will need to be addressed.

##### 5.2 Tools for Implementing an LID Maintenance Program

A range of administrative tools can be used to assist jurisdictions in implementing required maintenance activities for stormwater BMPs, such as Silva Cells. The tools vary depending on jurisdiction requirements, but may include (Ecology 2013b):

- Stormwater requirements (i.e., Code, manual, ordinance)
- Legal agreements between private or public owners and the regulatory agency (i.e. access easements, property maintenance covenants, or transfer of ownership)
- Maintenance requirements specified as part of the design process
- Financial liability measures
- Record keeping and tracking requirements
- Inspection and maintenance checklists
- Inspection and maintenance schedules
- Mapping
- Owner education (public or private)

#### 6.0 Additional Resources

The following resources provide additional information on maintenance of LID facilities applicable to Silva Cells.

- Western Washington Low Impact Development Operations and Maintenance Guidance Document <http://www.ecy.wa.gov/programs/wq/stormwater/municipal/LID/TRAINING/OperationsAndMaintenance.html>
- LID Technical Guidance Manual for Puget Sound <http://www.wastormwatercenter.org/files/library/lid-manual-2012-final-secure.pdf>
- International Society of Arboriculture <http://www.isa-arbor.com/education/publications/index.aspx>

- EPA's Integrated Pest Management (IPM) principles site  
<http://www.epa.gov/pesticides/factsheets/ipm.htm>
- Water Environment Research Foundation (WERF) BMP and LID Whole Life Cost Tool  
[http://www.werf.org/c/KnowledgeAreas/Stormwater/ProductsToolsnonWERF/BMP\\_and\\_LID\\_Whole\\_Li.aspx](http://www.werf.org/c/KnowledgeAreas/Stormwater/ProductsToolsnonWERF/BMP_and_LID_Whole_Li.aspx)
- Chesapeake Stormwater Network  
<http://chesapeakestormwater.net/training-library/stormwater-bmps/>
- Los Angeles County Department of Public Works, Stormwater BMP Design and Maintenance Manual  
<http://dpw.lacounty.gov/idd/publications/Stormwater%20BMP%20Design%20and%20Maintenance%20Manual.pdf>
- Low Impact Development Center  
<http://www.lowimpactdevelopment.org/links.htm>

## 7.0 References

- DeepRoot 2011. Silva Cell Operations Manual, prepared by DeepRoot Green Infrastructure LLC (DeepRoot), 2011.
- DeepRoot 2014. Personal communications between Graham Ray, President of DeepRoot, and Robin Kirschbaum, Senior Engineer of HDR, regarding expected design life of Silva Cells in typical pedestrian application. September 2, 2014.
- Ecology 2013a. Washington State Department of Ecology (Ecology) Equivalent Technology Website (<http://www.ecy.wa.gov/programs/wq/stormwater/newtech/equivalent.html>), accessed on June 9, 2014.
- Ecology 2013b. Western Washington Low Impact Development (LID) Operation and Maintenance (O&M) Guidance Document, prepared for Washington State Department of Ecology Water Quality Program, July 8, 2013.
- EPA 2014. Incorporating LID Website (<http://www.epa.gov/region1/npdes/stormwater/assets/pdfs/IncorporatingLID.pdf>), accessed on June 9, 2014.

## Appendix A

### DeepRoot Warranty

DeepRoot® warrants to the original purchaser of its Silva Cell™ product that such product will be free from defects in materials and workmanship, and perform to DeepRoot's written specifications for the warranted product, when installed and used as specifically provided in the product's installation guidelines for a period of 20 years from the date of purchase. This warranty does not cover wear from normal use, or damage caused by abuse, mishandling, alterations, improper installation and/or assembly, accident, misuse, or lack of reasonable care of the product. This warranty does not apply to events and conditions beyond DeepRoot's control, such as ground subsidence or settlement, earthquakes and other natural events, acts of third parties, and/or Acts of God. If this warranty is breached, DeepRoot® will provide a replacement product. Incurred costs, such as labor for removal of the original product, installation of replacement product, and the cost of incidental or other materials or expenses are not covered under this warranty.

DEEPROOT® MAKES NO OTHER WARRANTIES, EXPRESS OR IMPLIED, AND SPECIFICALLY DISCLAIMS THE WARRANTY OF MERCHANTABILITY OR FITNESS FOR A PARTICULAR PURPOSE. DEEPROOT® SHALL NOT BE LIABLE EITHER IN TORT OR IN CONTRACT FOR ANY DIRECT, INCIDENTAL OR CONSEQUENTIAL DAMAGES, LOST PROFITS, LOST REVENUES, LOSS OF USE, OR ANY BREACH OF ANY EXPRESS OR IMPLIED WARRANTY.

Some states do not allow the exclusion of incidental or consequential damages, so the above limitations and exclusions may not apply to you. This Warranty gives you specific legal rights, and you may also have other legal rights, which vary from state to state, or in Canada, from province to province.

Appendix B

City of Toronto Tree Planting Solutions  
in Hard Boulevard Surfaces;  
Best Practices Manual

Project # A21065  
Date February 8, 2013  
Recipient City of Toronto  
Submitted by DTAH, Lead Consultant  
ARUP, Engineering  
James Urban, Urban Trees + Soils



**dtah** | ARUP | James Urban | Urban Trees + Soils | Urban Forest Innovations Inc.

### Consultant Team

DTAH Adam Nicklin, Gerardo Paez-Alonso, John Hillier, Clara Kwon, Michelle Lazar, Donna Bridgeman, Karen Honsinger, Elnaz Sanati, Ayako Klitta, Johanna Evers, Jacob Mitchell, Bob Allsopp, René Biberstein

ARUP Harold Sich, Ken Bontius

Urban Trees + Soils James Urban

Urban Forestry Innovations Philip van Wassenaer, Alex Satel

Client - City of Toronto

Major Capital Infrastructure Coordination Doodnauth Sharma

### Acknowledgments

#### City of Toronto

*Parks, Forestry & Recreation* Peter Simon, Mark Ventresca, Julia Murnaghan, Mark Mullins

*City Planning* Robert Freedman, Jane Welsh, Sheila Boudreau

*Toronto Water* Patrick Cheung, Carmelo Pompeo

*Technical Services* Mario Goolsarran, Chris Myers, Nhat-Anh Nguyen, Peter Pilateris, Wai Yeung

*Transportation Services* Andre Rudnicky, Elyze Parker, Susan Samuels, Robert Mays

*Waterfront Secretariat* Chris Ronson

*Economic Development & Culture* Antonella Nicaso

*Enbridge Gas* Rob Milne, Vince Cina

*Toronto Public Utilities Coordinating Committee (Cogeco Data Services)* Patricia Ritchie

DeepRoot Canada Mike James

Citygreen Jeremy Bailey

ACO Steven Tonaj

Gro-bark

Earthco Soil Mixtures



## TABLE OF CONTENTS\*

Executive Summary	17
3.0 Construction Methods & Repair Regimes	18
3.1 Type-1: Pavement bridge system	18
3.2 Type-2: Soil cells system	18
3.3 Type-3: Open planter system	18
3.4 Hybrid solution and retrofits	18
3.5 Sub-standard sidewalk conditions	18
3.2 Type-2: Soil Cell System	19
7.0 Demonstration Projects	21
7.1 Toronto Water utility access exercise	21
7.2 Enbridge Gas lateral line and riser installation	21
7.3 Bloor St. W. at Dovercourt Rd. and Concord Ave. demonstration project	21
7.1 Toronto Water Utility Access Exercise	22
7.2 Enbridge Gas Lateral Line and Riser Installation	25

\* Please note: Appendix B contains excerpts from the City of Toronto's Tree Planting Solutions in Hard Boulevard Surfaces Best Practices Manual. For full document with all content please contact the Urban Forestry Department at [311@toronto.ca](mailto:311@toronto.ca)

## Executive Summary

The City of Toronto has established a goal to increase both the number and size of its street trees (*Toronto Street Trees: Guide to Standard Planting Options*, April 2010). The City aims to grow large-canopy trees in hard boulevard surfaces that have a complete 40+ year life span and are 40 cm in diameter at breast height.

This manual examines and provides cost-efficient options to reach this goal.

Downtown streetscapes are harsh environments for trees, and many do not survive or never grow to a large canopy size. Large-canopy trees provide enormous climatic, environmental, health, aesthetic and psychological benefits. There is room for considerable improvement in the quality of the urban forest in downtown streetscapes and this report examines how this can be done.

**Section 1** of this report, the Introduction, defines ‘criteria for success’ for urban tree planting in Toronto, and sets the tone for the manual and its future implementation.

**Section 2** provides fundamental principles for growing large trees. At minimum, trees require 20 to 30 m<sup>3</sup> of soil each in order to grow to maturity. In order to achieve this, integration of soil/root zones with utilities is proposed to reach the target soil volume under urban sidewalks. Larger openings in the pavement also help to increase longevity. Cost savings are achieved by eliminating unnecessary hardware and designing structural concrete to withstand the load of occasional snowploughs and service vehicles, but not firetrucks.

**Sections 3 and 4** provide various technical solutions that have been developed as part of this manual. They address both new and retrofit construction and repair techniques to respond to a variety of site-specific requirements

such as sidewalk width, public realm condition, and infrastructure arrangement for a range of budgets.

**Section 5** evaluates essential material components that are required for successful tree growth in an urban streetscape. These are tree opening area materials such as mulch; flexible plastic mesh bark protectors; passive rainwater harvesting and distribution; and root zone ID markers to prevent construction damage.



Sidewalk trees on Yorkville Ave.

**Section 6** offers insightful information to ensure that each planted tree has the best opportunity to thrive. Horticultural topics such as tree preservation, installation and maintenance, tree species suitability, nursery stock quality and soil specific requirements are discussed.

Lastly, **Section 7** documents two demonstration projects where the City of Toronto and consultants field-tested a number of the tree planting construction methods. A water main break scenario was recreated and a gas lateral and riser were installed through soil cells. In both cases, the soil cells posed no significant hindrance to utility work.

The **Appendices** include construction drawings, specifications, cost estimates, letters of product availability, responses to City comments and the street tree precedents review.

Section 4 Arrangements	Section 3 Types			
	3.5m min. sidewalk width		5.7m min. sidewalk width	
	TYPE 1: Pavement Bridge		TYPE 2: On-Grade Pavement Over Soil Cells	TYPE 3: Open Planter
1A	1B			
Growing Medium Trench	X	X	X	
Open Planter with Curb Edge				X

Compatibility between types identified in Section 3 and arrangements identified in Section 4.

### 3.0 Construction Methods & Repair Regimes

Three different systems for tree planting in sidewalks are laid out in this section. They form the basis for the proposed City of Toronto tree planting details that accompany this report in the Appendices. In addition, this section makes recommendations for hybrid solutions and retrofits and dealing with sub-standard sidewalk conditions.

#### 3.1 Type-1: Pavement bridge system

A structural pavement surface or subsurface spans between supporting ends over the growing medium trench. Reinforced precast and cast-in-place concrete panels provide the 'bridge'. Refer to the T-1A and T-1B Construction Drawings in Appendix A.

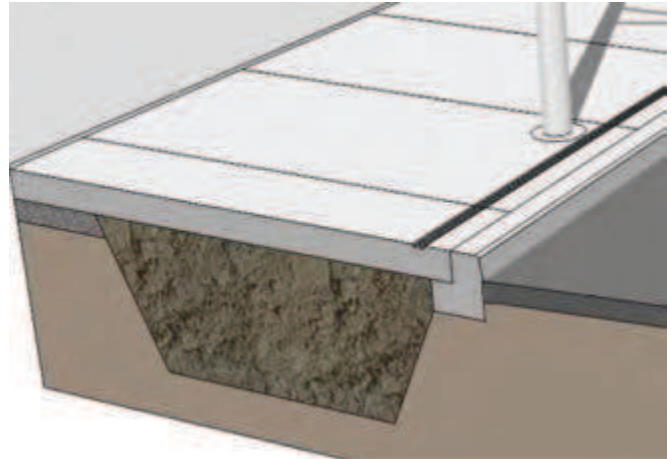

3.1 Type 1: Pavement bridge system

#### 3.2 Type-2: Soil cells system

Modular rigid soil cells support a pavement system above the growing medium. The pavement surface and base can be built directly on top of the hard deck of the soil cells. Refer to T-2 Construction Drawings in Appendix A.

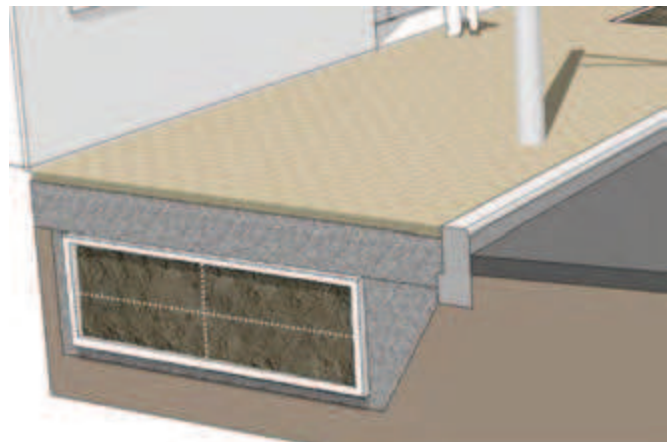

3.2 Type 2: Soil cells system

#### 3.3 Type-3: Open planter system

There is no paving around the tree base. Where there is space for this system on the sidewalk, it is the most cost-efficient option available for growing large urban trees. Refer to T-3 Construction Drawings in Appendix A.



3.3 Type 3: Open planter system

#### 3.4 Hybrid solution and retrofits

The street is not rebuilt wholesale, just one or two trees in a block may be affected.

#### 3.5 Sub-standard sidewalk conditions

Conditions where the existing space or utility constraints are such that the standards advocated in this report are not achievable.

*Note: In the following descriptions for utility compatibility with various construction methods, review is based upon the general feasibility of working with such utilities and repairs. Ultimately, individual utility companies and City departments will have to reach an agreement for the access and repair of the various conditions generated, and the responsibility thereof. The recommendations in this report are intended to provide a framework for these policy decisions to be made.*

### 3.2 Type-2: Soil Cell System

On-grade pavement over soil cells allows for traditional pavement on-grade on top of the soil cell assembly and has been used in a number of pilot projects in Toronto and other North American cities. This system requires utility companies and City agencies to become comfortable with the concept of a modular support system, and will require a new protocol to include removal and replacement of the soil cells.

Construction Drawings T-2 in Appendix A provides details on this system.

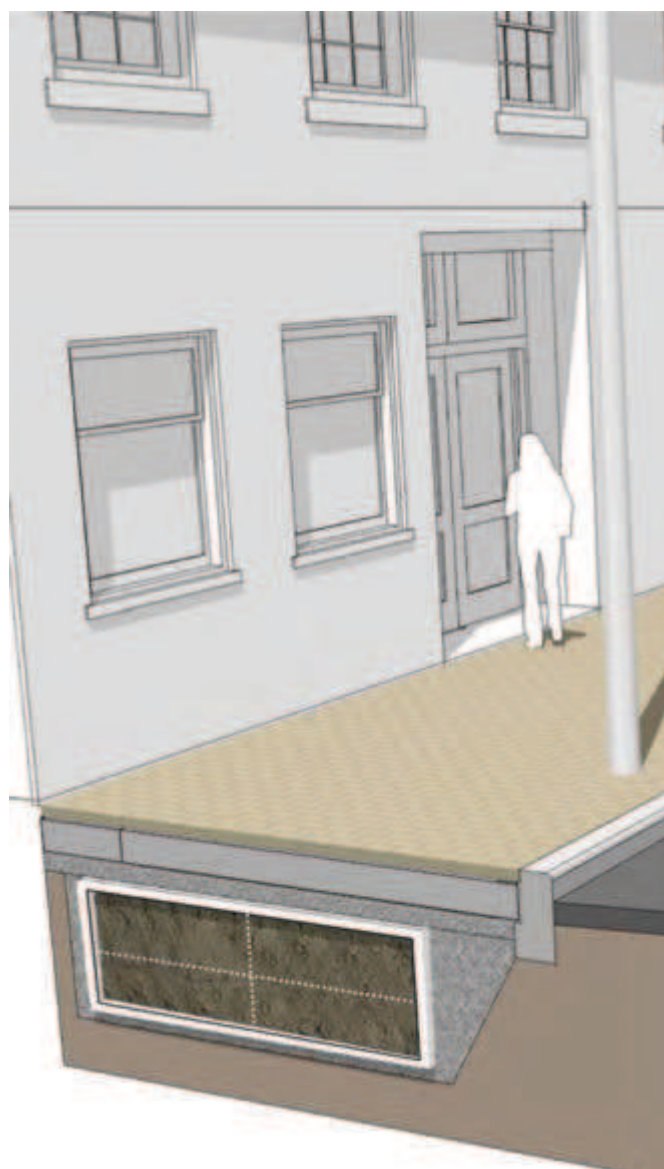

Type 2: On-grade pavement over soil cells

#### Construction

Space allotted for root zone and foundation are excavated out, and a compacted granular base is installed for the soil cells. Soil cells are installed per manufacturer's instructions. The pavement system is installed with granular base above the soil cells. The new paving can be installed in a similar way to any on-grade pavement system.

#### Utility access

Where there is concrete, the pavement is sawcut. Where there is unit paving, the pavers are removed. Filter fabric is peeled back, and soil cells are removed and set aside. In frozen conditions, the soil cells may be removed forcibly with an excavator, requiring them to be replaced with new soil cells prior to repairing surface paving. Once soil cells are removed, the utility is accessed via excavation of planting soil or granular below.

#### Repair

After the utility is backfilled with granular to the underside of the root zone and compacted, soil cells are reinstalled per manufacturer's instructions. Filter fabric is laid down on top of replaced soil cells, then pavement system is made good either temporarily or permanently.

#### Recommended utilities compatible with root zone

On-grade pavement over soil cells is generally compatible with utilities below the root zone, ideally where frequent access is not anticipated. Some shallower utilities may be compatible for placement within root zone/soil cell zone depending on agreement with the utility company concerned such as gas or hydro laterals.

- Utilities below root zones:
- New generation storm line (concrete)
- New generation sanitary line (concrete)
- Concrete-encased hydro duct, combined data
- District energy
- Pressurized water main
- Gas (main or lateral)
- Bare conduit (street lighting, telephone, etc.)

### Surface finish

Since the structural support is provided by the soil cells, the pavement system can be any type or finish such as concrete or unit paving over concrete.

### Pros / cons

If the work crew is comfortable removing and replacing soil cells, the access and repair procedure is similar to current practices. The pavement system is equivalent to an on-grade construction. It can be repaired as a permanent repair or a temporary two-stage repair.

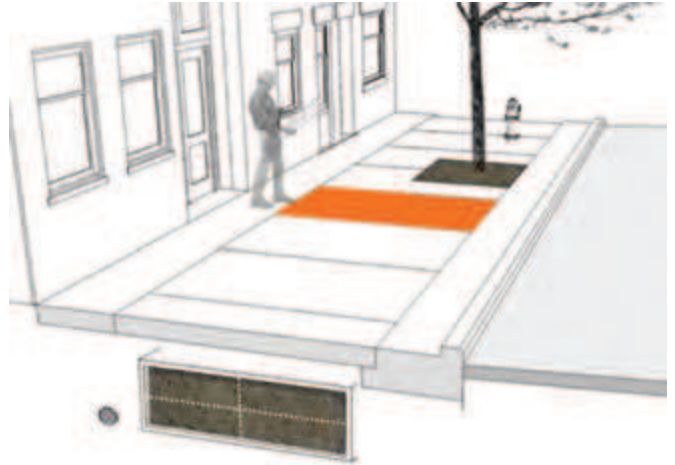

Utility access, step 1

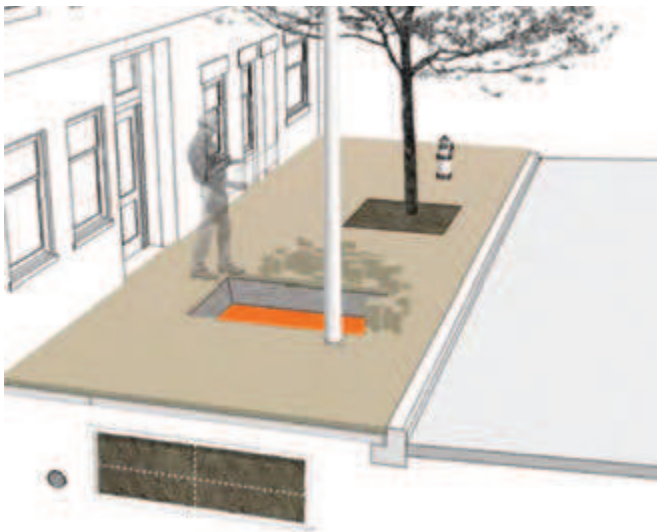

Utility access with pavers, step 1

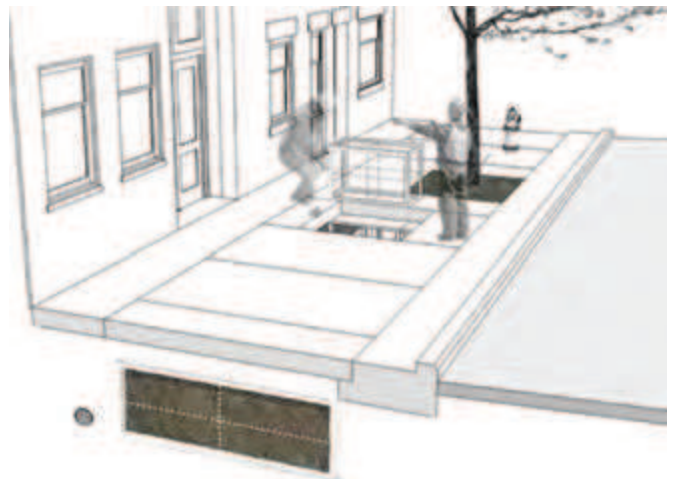

Utility access, step 2



Utility access with pavers, step 2

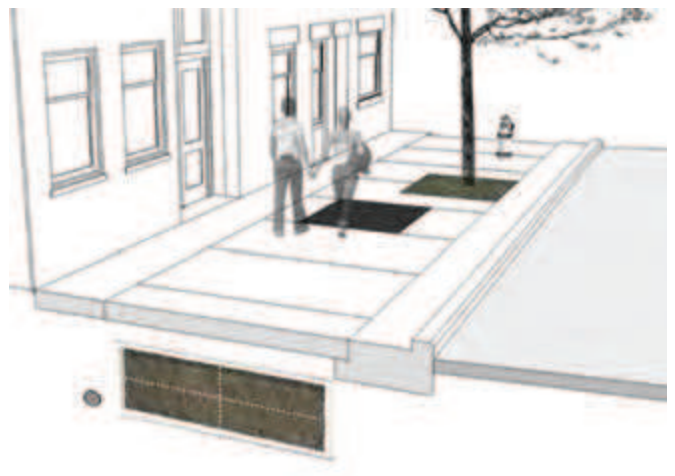

Utility access, step 3

### 7.0 Demonstration Projects

The consultants and the City organized a soil cell testing exercise at the City of Toronto’s Nashdene Yard in Scarborough with utility stakeholders Toronto Water and Enbridge Gas. New utility installation and repair of existing utilities under soil cells was recreated at the Yard:

#### 7.1 Toronto Water utility access exercise

Toronto Water recreated an “emergency scenario” in the middle of winter (Feb. 24, 2012). The scenario involved bursting a water main and testing the effects of water leaking on the soil cell system.

#### 7.2 Enbridge Gas lateral line and riser installation

Enbridge Gas tested access through soil cells to install a gas lateral line.

#### 7.3 Bloor St. W. at Dovercourt Rd. and Concord Ave. demonstration project

A further on-site demonstration project was proposed. However, it was decided not to be implemented as part of this study, due to a larger upcoming resurfacing project in the area.

*Note: The soil cell product used at Nashdene Yard was Silva Cells, manufactured by DeepRoot Green Infrastructure, LLC.*



Soil cell trench filled with soil.

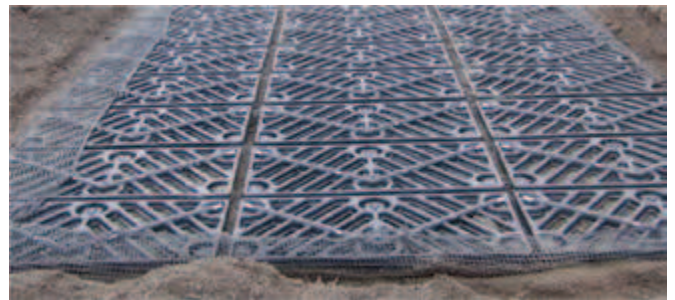

Soil cell decking system.



Backfill installation on top of deck.



Finished installation.



Nashdene Yard location, Scarborough.

## 7.1 Toronto Water Utility Access Exercise

### Description of the exercise

The cold weather conditions, at  $-4^{\circ}\text{C}$  ( $-10^{\circ}\text{C}$  with wind chill) provided Toronto Water field personnel a good test for working with soil cells in adverse conditions.

The exercise began at 8:00 am with an on-site briefing where the demonstration project coordinators and Toronto Water personnel discussed the different activities and the order of execution. Water was then turned on into the installed water pipe which was capped on both ends and pre-cut during its installation under the soil cell system. Water fed from a hydrant at 414 kPa ran for approximately three minutes before it started to come out through the already saturated soil adjacent to the demonstration sidewalk. After the water valve was shut off, the following activities took place:

### Concrete sidewalk pavement was removed

- Concrete pavement was saw cut into blocks that could later be removed by a backhoe.
- Removal of concrete and granular 'A' base below concrete paving.
- Crew located a geotextile layer that was installed below the granular 'A' and on top of the soil cell top frame deck; the geotextile was cut to expose the soil cell deck.
- Manual removal of two of six soil cell top decks were set aside for re-installation.



Water pipe cut.



Sawcutting concrete pavement.



Water introduced - water bursting out of saturated soil adjacent to installation.



Mechanical removal of pavement to expose soil cell decking system.



Manual removal of two decks, unscrewed and set aside for future re-installation.



Excavation below bottom of soil cells to daylight water pipe.



Mechanical removal of soil cells.



Excavation below bottom of soil cells to daylight water pipe.



### Mechanical removal of soil cells, soil and sub-base

- Backhoe was used to dig out and through soil cells and soil.
- Water pipe was daylighted.

### Repair

- The dug trench was temporarily repaired afterwards with unshrinkable fill up to finished grade.
- Weeks later, unshrinkable fill was broken up to the bottom of the first layer of soil cells to restore the cells and surface finishes to the original condition.

### Conclusions of the Toronto Water exercise

Once the soil cells were removed, the stakeholders discussed the outcome and lessons learned from the exercise. It was concluded that Toronto Water can easily access its infrastructure through the soil cell system under extreme conditions using the same methods they currently have in place in either a planned or emergency situation. The exercise allayed their concerns that the soil cells would be a hindrance in their field work. Further discussions of a vertical minimum clearance between the utility and the bottom of the soil cells are expected.

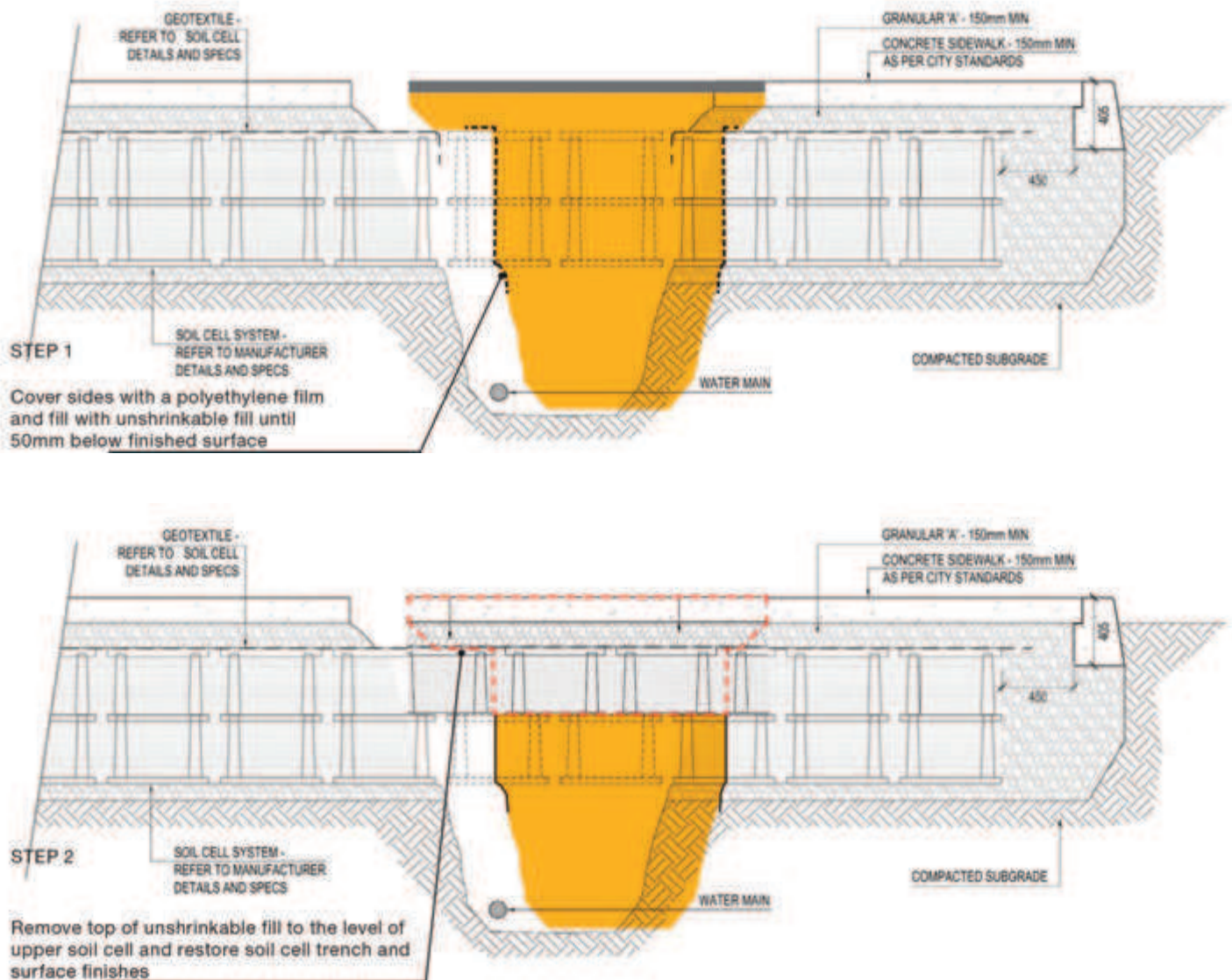

## 7.2 Enbridge Gas Lateral Line and Riser Installation

### Description of the exercise

The exercise began at 9:00 am at Nashdene Yard in Scarborough on a late-May day that was partly cloudy and warm. A gas lateral with a long riser was installed under a sidewalk cross-section of unit paving and soil cells. Using a mole with the shortest torpedo hammerhead at 1.0 m length, the 25 mm gas line was bored through the growing medium and adjacent subgrade. Excavation was only necessary at each end of the gas lateral. For longer horizontal drilling, a directional drill is used which has greater directional control. Enbridge usually uses a torpedo mole for downtown work, which requires less excavation and can be used for horizontal drilling through sidewalk cross-sections. It can drill through tree roots and is only blocked by large rocks. The following took place:

### Setting the direction and starting point of the horizontal boring

- Mock building and road sides of the sidewalk were designated for the purposes of this exercise.
- Unit pavers and granular base were removed to locate and confirm the cell deck edge. The torpedo was set to drill horizontally between the soil cell frame legs from the side.
- The crew dug down two cells deep between the building side and the cell, until there was enough room to slide the riser through. Where there is not enough room to dig behind the cell, the cell can be removed to install the riser.
- In alignment with the pit dug at the building end, another pit was dug down approximately 1.2m deep at the road end of the lateral.

### Directional boring

- The torpedo was first set to begin at the building side where the riser would be placed. The torpedo did not make it out at the road side because it had great difficulty going from soft material to hard material (i.e.. growing medium to hard clay subgrade) as it does not have enough friction to propel it forward.
- The torpedo was reset to begin on the road side. It bored through the road subgrade then through the soft growing medium and came out at the building side.



Removal of pavers and granular base.



Geotextile is cut through centre of cell deck.



Digging down approximately two cells deep at both lateral ends.

Pulling the lateral through, attaching and setting the riser

- The torpedo was removed and the lateral pipe was attached to the hose end and pulled through.
- The riser was fused to the pipe end and pulled through and set at the correct elevation.
- Granular was backfilled into the cavity.



Torpedo set to begin at the imaginary building end of the lateral line.



Torpedo emerges through growing medium and cell decks on the imaginary building side.



Torpedo and hose are pulled up and out of the pit.



After false start on imaginary building end, torpedo is reset at road end.



Pulling the lateral through the cells and growing medium.



End of lateral at building end.



Cover over the cell deck with the cut geotextile and add an overlapping layer of geotextile on top.



Riser is attached and pulled through.



Backfill and ensure riser is set correctly. Conclusions of the Enbridge Gas exercise

### Conclusions of the Enbridge Gas exercise

It was concluded that the soil cells pose no obstruction to the installation of a gas lateral and riser. The work is essentially the same as current sidewalk conditions with a few extra considerations. The crew must locate the boundary of the cell frame to set the torpedo to go between the cell deck legs and not collide into them. The crew must be mindful that the growing medium is easily permeable and that the torpedo bores move easily from hard to soft matter and not the other way around. Paving removal need only be limited to where the riser needs to go and the area needed to slide it into place. Where there is enough room between the soil cells and building face to excavate and install the riser, paving on top of the cells could stay intact.

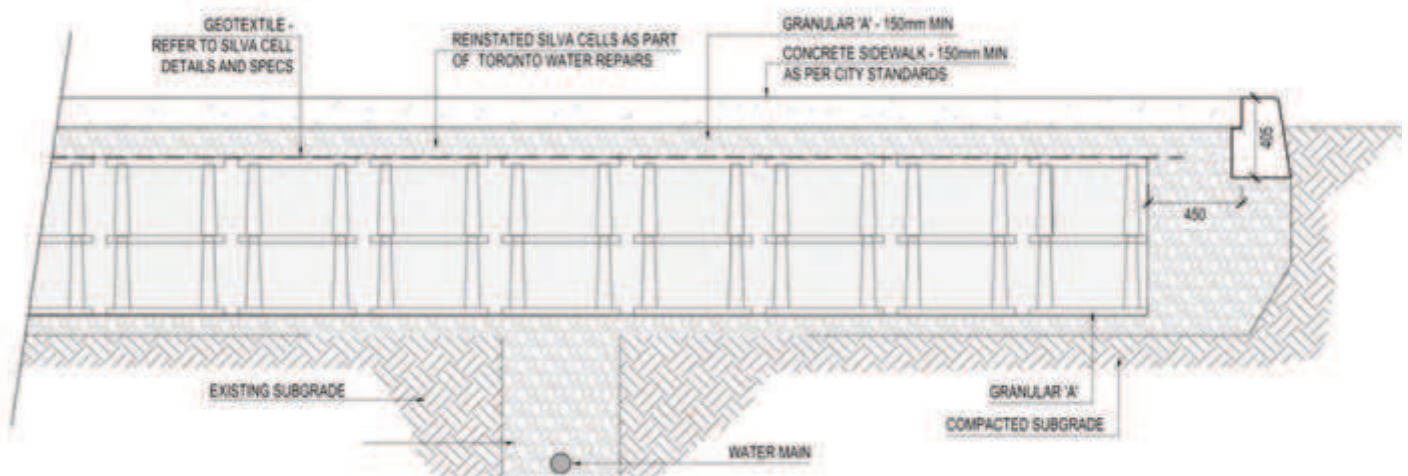

## Appendix C

### Protection and Maintenance

DeepRoot Green Infrastructure, LLC  
USA-Head Office  
101 Montgomery Street, Suite 2850  
San Francisco, CA 94104  
info@deeproot.com  
Tel: 800 458 7668 or 415 781 9700  
Fax: 800 277 7668 or 415 781 0191

*Notes: Each Silva Cell stack is independent of the Silva Cell stack adjacent to it – therefore if individual Silva Cells are disturbed, the entire system is not compromised.*

*Silva Cell frames (or base and posts) and decks should at no time be cut, drilled into, or otherwise structurally modified during any installation, inspection or maintenance procedure. Any damaged Silva Cell frames (or base and posts) or decks shall be replaced.*

#### 1.0 Protection of The Silva Cell System

To help avoid future disturbance of the Silva Cell system the location of the system should be accurately recorded at the time of construction and incorporated into an as-built drawing.

If possible register the location of the Silva Cell system with the local One-Call utility locating program.

Accurately locate the limits of the Silva Cell system prior to any future excavation in the area. (Some types of underground utility locating equipment, such as ground penetrating radar, are capable of detecting Silva Cells and may be used to locate the limits of the system. Contact a professional utility locating contractor for more information).

Utility warning tape/ribbon and locating wires can also be incorporated into the system and are recommended.

#### 2.0 Utility Installation, Maintenance, Relocation or Replacement within Silva Cell System

If the Silva Cell system is accidentally unearthed by future excavation in the area, cease the excavation immediately and consult the as-built drawings to determine the limits of the system.

Using hand tools only, expose the impacted portion of the Silva Cell system and carefully inspect the Silva Cell frames (or base and posts) and decks for any signs of damage or cracking.

Replace any damaged Silva Cell frames (or base and posts) or decks and reconstruct any disturbed portion of the system as per DeepRoot's installation Guidelines.

The Silva Cell system supports vehicle loading equal to 32,000 lbs (14,500 kg) per axle, which allows use in areas that accommodate 3 - 4 axle vehicles such as those used for emergency, delivery, and maintenance. Generally meets AASHTO HS-20 (USA), CSA-S6, 87.5 and OBC 54KN (Canada), and BS EN 1991-1-1:2002 and BS EN 1991-1-2:2003 (UK) loading standards when used with standard paving profiles.

Throughout this document, where H-20 loading is referred to, this is shorthand for the loading standards described above.

To prevent damage to underlying Silva Cells, ensure that machinery operated on the paving above does not exceed loading as described above. Do not operate any machinery over the Silva Cell system without paving being in place.

### 3.0 Utilities and Accessing The Silva Cell System

The Silva Cell system can be easily accessed for utility installation, maintenance, relocation, replacement, etc. using the following procedure.

First, locate the limits of the Silva Cell system.

Carefully remove the existing pavement. Take care to not operate machinery exceeding H-20 loading on any of the surrounding pavement supported by the system. Do not operate any machinery over the Silva Cell system once the pavement has been removed.

Using hand tools remove the aggregate base course and expose the underlying geotextile fabric. If working near the perimeter of the system there will be also be approximately 12" (30.5 cm) of geogrid that is folded over and attached to the cell decks. Cut the geotextile fabric as needed to allow for the removal of Cell decks. If Geogrid is encountered, detach it from cell decks and fold it back as well. Do not cut the Silva Cell frames (or base and posts) or decks. Remove the Silva Cell decks by removing the four corner screws and set it aside. Remove the soil from inside the frames using hand tools only or a HydroVac. (If the existing soil is to be reused, store it separately to ensure that it does not become contaminated with other spoil material. Otherwise dispose of the soil and replace it with soil meeting the requirements specified for the project. All soil must be inspected and approved prior to reinstallation.) Carefully remove any of the frames (or base and posts) needed to complete utility work. Upon completion of the utility work visually inspect the surrounding exposed Silva Cell parts and remove any of those showing signs of damage or cracking. Restore the disturbed portion of the system using one of the two following methods:

#### Method 1:

Replace the Silva Cell frames (or base and posts), soil and decks as required per Silva Cell installation details and specifications. Re-wrap geogrid over decks with an overlap at cut seam. Restore the aggregate base course and pavement. Re-use only Silva Cell frames

(or base and posts) and decks that have been thoroughly inspected and found to be free of damage or cracking. Replace any parts showing signs of damage or cracking with new.

#### Method 2:

Structurally bridge the gap with 1 1/2" (3.8 cm) clear stone. Install geogrid around the perimeter of the area from which the Silva Cells were removed per DeepRoot's construction guidelines. Fill inside void area with 1 1/2" (3.8 cm) clear stone up to the level of the adjacent Silva Cell decks. Cover the stone with geotextile fabric making sure to overlap the existing geotextile fabric by a minimum of 2 feet on all sides. Restore the aggregate base course and pavement.

### 4.0 Pavement Repair or Replacement over Silva Cell System

When the existing pavement over a Silva Cell system is to be replaced by a different type of pavement, refer to the Silva Cell standard details and specifications. A change in surface materials may require a change in the depth of the underlying aggregate base course.

### 5.0 Adding Silva Cells to The System/Removing Silva Cells from The System

To make changes to the size of the Silva Cell system, locate the limits of the system. Carefully remove the pavement taking care to ensure that no machinery which exceeds H-20 loading is operated on pavement supported by the Silva Cells and that no machinery is operated over the Silva Cells once the pavement has been removed. Using hand tools remove the aggregate base and expose the underlying geotextile fabric. Cut the geotextile fabric as needed to visually confirm the limits of the Silva Cells. Excavate to no closer than 1' (30.5 cm) of the limits of the Silva Cells. Using hand tools, expose the geogrid which wraps the perimeter of the system. Cut and fold back the geogrid as needed to add or remove cells. If adding to the system, install the new Cells per Silva Cell specifications. Ensure that the gap between the existing Silva Cell frames (or base and posts) and

the new Silva Cell frames does not exceed the 3" (7.6 cm) maximum. If removing frames (or base and posts) or decks, re-install the geogrid along the new perimeter of the Silva Cell system and backfill along the new limits of excavation per Silva Cell specifications.

### 6.0 Tree Replacement

Tree replacement may be necessary based upon unforeseen or severe site, climate or circumstantial conditions. Limit disturbance area as possible. Ensure all equipment meets H-20 loading requirements.

Remove any structure at the tree opening (tree grate, etc.) Remove mulch and any excess soil from above tree root package. Do not damage Silva Cell frames (or base and posts) or decks. Remove soil using hand tools only or HydroVac and set aside. If hand dug, ensure clean storage of soil material by excavating into contained/isolated location and cover during utility work. Soil must be inspected and approved prior to reinstallation.

Consult a certified arborist to remove tree. If necessary to cut tree roots from main root package, do not cut Silva Cell frames (or base and posts) or decks. Remove tree root package from planting bed. If using construction equipment to remove tree, ensure meeting of H-20 loading requirements.

Prior to planting new tree, install additional planting soil, to the depths indicated, within the tree opening adjacent to paving supported by Silva Cells. Assure that the planting soil under the tree root package is compacted to approximately 85-90% to prevent settlement of the root package. The planting soil within the tree opening shall be the same soil as in the adjacent Silva Cells. See Silva Cell specifications for further detail. Replace root barrier.

Plant tree according to owner specifications or at the direction of consulting arborist. Cover the planting soil finished grade with 2" (5cm) of mulch per Silva Cell specifications.

When a large portion of a Silva Cell installation is to be removed, first locate the area of disturbance. Limit disturbance area as possible. Ensure all equipment meets H-20 loading requirements.

Remove paving and aggregate base course. Carefully cut geotextile to allow for removal of Cell decks. Ensure at least 18" (45.7 cm) overlap into new limits of excavation. Do not cut Silva Cell frames or decks. Unfold geogrid from Cell decks and carefully fold away from Silva Cell frames (or base and posts). Remove Silva Cell decks by removing screws and set aside. Remove soil using hand tools only or HydroVac and set aside. If hand dug, ensure clean storage of soil material by excavating into contained/isolated location and cover during utility work. Soil must be inspected and approved prior to reinstallation. Remove anchoring spikes from Cell base and set aside. If geotextile is at base of system, carefully cut geotextile at least 6" (15.2 cm) within new limits of excavation.

Install aggregate base course and paving, ensuring no damage to Silva Cells or other installation components.

### 7.0 Additional Silva Cells to be Installed Adjacent to Existing Installation

When additional Silva Cells are to be installed adjacent to an existing Silva Cell system, first locate the area of disturbance. Limit disturbance area as possible. Ensure all equipment meets H-20 loading requirements.

Excavate up to 12" (30.5 cm) from existing Silva Cells. Excavated remaining 12" (30.5 cm) by hand. Cut geogrid from face of existing Silva Cell system. Do not cut Silva Cell frames (or base and posts) or decks.





Corporate Offices:

✉ DeepRoot Green Infrastructure, LLC  
530 Washington Street, San Francisco, CA 94111

☎ 800 1LV ROOT (458.7668) ✉ 800.277.7668

🌐 [www.deeproot.com](http://www.deeproot.com)

Canada:

✉ Deep Root Canada Corp.  
#201 2425 Quebec Street, Vancouver, BC V5T 4L6

☎ 604.687.0899 ✉ 604.684.6744

United Kingdom:

✉ DeepRoot Urban Solutions, Ltd.  
6 Dorset Street, London W1U 6QL, United Kingdom

☎ (+44) 020 3848 4230 ✉ +44.207.969.2800

# STORM WATER QUALITY UNITS

Standards for storm water quality will necessarily vary by location and land use.

The most targeted sources of runoff pollution are paved areas in urban and industrial sites. These are generally small (< 1 acre) with high traffic loads, such as parking lots and gas stations, that generate significant concentrations of contaminant particles and hydrocarbons.

Because of land constraints, Hancor underground Storm Water Quality Units\* have become an increasingly efficient solution for treating storm water. These durable, lightweight structures have been specifically designed for fast installation and easy maintenance.

## BENEFITS

- Laboratory tests have shown an 80% TSS removal rate.
- Removes floatable debris, oils and greases.
- Available in 36" (900mm) through 60" (1500mm) diameters.
- Lightweight High Density Polyethylene (HDPE) unit installs easily with a minimum amount of manpower. Heavy cranes are not necessary to install the unit.
- Each unit is fitted with access risers for easy inspection and maintenance of the sediment and oil chambers.
- The unit is inexpensive because the design is simple and there are no moving parts.
- The bypass system prevents re-suspension of captured solids by diverting water flows greater than the first flush.
- HDPE resists abrasion and chemicals found in storm water and in the surrounding soil.

\*Patented



**The Patented Hancor Storm Water Quality Unit is lightweight and easy to install, requiring little in the way of manpower or heavy equipment.**

**A bypass system (below) is installed to prevent water flows greater than the first flush from re-suspending captured pollutant particles.**

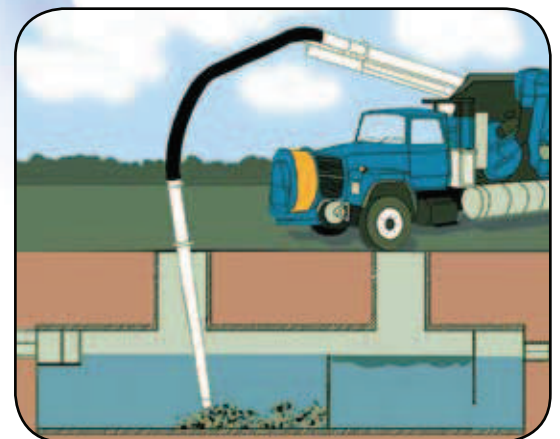
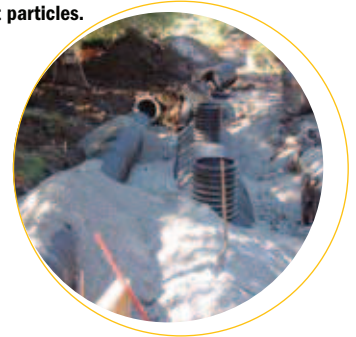

**The Hancor Storm Water Quality Unit is fitted with access risers for easy inspection and maintenance.**



# STANDARD MODELS

Product Number	Diameter (in) (mm)	Length (ft) (m)	Inlet Size (in) (mm)	Outlet Size (in) (mm)	Treated Flow Rate (cfs) (L/s)	Sed. Vol. (ft <sup>3</sup> ) (m <sup>3</sup> )	Oil Vol. (ft <sup>3</sup> ) (m <sup>3</sup> )	Sieve Size
3620WQA	36 (900)	20 (6)	10 (250)	10 (250)	1.5 (42)	65 (1.8)	30 (0.8)	140
3640WQA	36 (900)	40 (12)	10 (250)	10 (250)	2.38 (67)	137 (3.9)	63 (1.8)	140
3620WQB	36 (900)	20 (6)	10 (250)	10 (250)	0.7 (20)	65 (1.8)	30 (0.8)	200
3640WQB	36 (900)	40 (12)	10 (250)	10 (250)	1.6 (45)	137 (3.9)	63 (1.8)	200
4220WQA	42 (1050)	20 (6)	12 (300)	12 (300)	1.75 (49)	83 (2.3)	38 (1.1)	140
4240WQA	42 (1050)	40 (12)	12 (300)	12 (300)	3.66 (104)	175 (5.)	81 (2.3)	140
4220WQB	42 (1050)	20 (6)	12 (300)	12 (300)	0.86 (24)	83 (2.3)	38 (1.1)	200
4240WQB	42 (1050)	40 (12)	12 (300)	12 (300)	1.83 (52)	175 (5.)	81 (2.3)	200
4820WQA	48 (1200)	20 (6)	12 (300)	12 (300)	2.26 (64)	116 (3.3)	55 (1.6)	140
4840WQA	48 (1200)	40 (12)	12 (300)	12 (300)	3.94 (112)	245 (6.9)	115 (3.3)	140
4820WQB	48 (1200)	20 (6)	12 (300)	12 (300)	1.13 (32)	116 (3.3)	55 (1.6)	200
4840WQB	48 (1200)	40 (12)	12 (300)	12 (300)	2.39 (68)	245 (6.9)	115 (3.3)	200
6020WQA	60 (1500)	20 (6)	15 (375)	15 (375)	2.95 (84)	183 (5.2)	87 (2.5)	140
6040WQA	60 (1500)	40 (12)	15 (375)	15 (375)	6.23 (176)	385 (10.9)	184 (5.2)	140
6020WQB	60 (1500)	20 (6)	15 (375)	15 (375)	1.47 (42)	183 (5.2)	87 (2.5)	200
6040WQB	60 (1500)	40 (12)	15 (375)	15 (375)	3.12 (88)	385 (10.9)	184 (5.2)	200

140 sieve is equal to a particle size of 0.0042" (0.106mm) 200 sieve is equal to a particle size of 0.0030" (0.075mm)

## DESIGN VARIATIONS

The standard models listed above will provide efficient removal of pollutant particles and hydrocarbons for the majority of site conditions. For unusual conditions, Hancor can recommend a system combining a variety of sizes and configurations.

### PEAK FLOW RATE

The bypass pipe of the Hancor Storm Water Quality Unit is designed to convey the peak storm water flow of the storm line.

For example, @ a 1% slope, peak flow rates for the bypass line are as follows:

	CFS	L/S
12"	3.8419	103.9
15"	6.971	188.0
18"	11.343	307.0
24"	24.451	661.0
30"	44.37	1,240.0
36"	72.19	1,950.0
42"	108.95	2,950.0
48"	155.61	4,210.0
60"	282.36	7,630.0

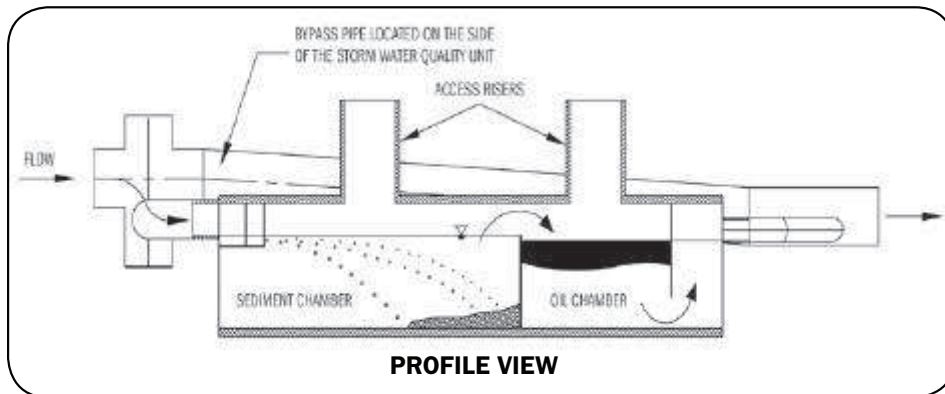

# DESIGN AND INSTALLATION

## DESIGN PRINCIPLES

Available in 36" (900mm) through 60" (1500mm) diameters, Hancor Storm Water Quality Units are modified sections of HDPE pipe with weir plates at certain locations and heights to remove high percentages of sediment and oils from the first flush of a storm event. They can be installed at any point in the subsurface drainage system, and are ideally suited to treat "hot spots" in existing storm water lines.

The unit is designed using the fundamental principles of Stoke's Law and standard orifice outlet control equations. The settling velocity of a particle is calculated based on the smallest particle to be removed. Standard units offer a choice of 140 or 200 sieve size removal.

The outlet orifice is sized to release a typical first flush discharge and to redirect any excess flow to a bypass piping system installed with the unit.

140 Sieve Size	200 Sieve Size
<b>0.0042"</b> <b>Particle Dia.</b> <b>0.106 mm</b>	<b>0.0030"</b> <b>Particle Dia.</b> <b>0.075 mm</b>

## SIZING AND INSTALLATION

Installation of Storm Water Quality Units follows the same accepted practices as the installation of large diameter flexible pipe.

Specific installation instructions, along with details on specifying the proper size of a Storm Water Quality Unit, are available on the Hancor web site at [www.hancor.com](http://www.hancor.com).





## THE HEART OF THE TREATMENT TRAIN

For many drainage sites, the Storm Water Quality Unit by itself can provide the required degree of pollutant removal. However, certain sites with higher concentrations of hydrocarbons or sediment runoff will need further treatment upstream and/or downstream of the Unit. This multi-tiered approach to storm water quality is known as the treatment train.

Upstream measures include sediment prevention (vegetated swales, etc.) and inlet protection devices such as screens, filters and silt fences. These techniques are designed to prevent a large percentage of pollutants from ever entering the storm drain system. For impervious surfaces such as paved parking areas, catch basin insert filters are most commonly used for early stage treatment.

### RETENTION/DETENTION

Treatment downstream from the Storm Water Quality Unit generally involves some form of retention or detention system. Retention allows accumulated storm water to gradually percolate into the surrounding soil, while detention meters the water through an outlet to a ditch, stream or other receiving area.

Inlet designs to such underground storage vessels can also enhance pollutant removal. The “eccentric header system” consists of a large diameter manifold pipe with an invert positioned lower than those of the smaller inlet pipes to the storage vessels. The large header pipe thus acts as a sump into which suspended particles may settle. Manholes and/or risers may be installed to facilitate inspection and cleaning.

Designers can choose between two methods of constructing the retention or detention system. The first is the use of Hancor large diameter corrugated high density polyethylene pipe, known for its economy and ease of installation. The second option is LandSaver™ – specially engineered to meet the demands of subsurface storm water management applications. Hancor supplies a complete line of pipe, fittings and fabricated manifolds, along with detailed sizing, design and installation instructions on [www.hancor.com](http://www.hancor.com).

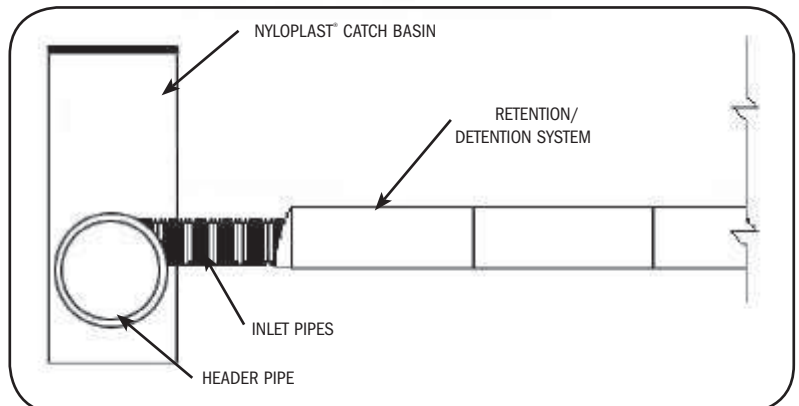
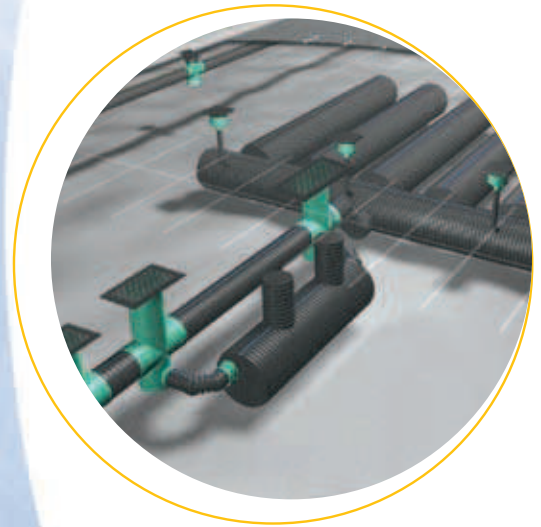

The “eccentric header” is installed with its invert lower than the inlet pipes, thus acting as a sump to collect suspended sediment.



# HANCOR STORM WATER QUALITY UNIT PRODUCT SPECIFICATION

## SCOPE

This specification describes 36- through 60-inch (900 to 1500mm) Storm Water Quality Units for use in on-site point source storm water treatment applications.

## REQUIREMENTS

Storm Water Quality Units shall have a smooth interior and annular exterior corrugations. The unit shall have a least three containment zones, each zone separated from the next by use of a weir or baffle plate.

Weir and baffle plates shall be welded at all interfaces between the plate and water quality unit.

First weir plate shall incorporate a saw tooth design and shall be reinforced with stiffeners positioned horizontally on the downstream side of the plate to be retained.

Storm Water Quality Units shall provide adequate clean-out and inspection access.

## JOINT PERFORMANCE

Connections for the bypass line and the unit shall utilize the same joint quality as specified for the main storm sewer pipe. Couplers for the bypass line may be either split couplers, in-line bell couplers, snap couplers, bell-bell couplers, or welded bell couplers.

## MATERIAL PROPERTIES

Virgin material for pipe & fittings used to produce Storm Water Quality Units shall be high density polyethylene conforming with the minimum requirements of cell classification 424420C for 4- through 10-inch (100 to 250mm) diameters, and 435400C for 12- through 60-inch (300 to 1500mm) diameters as defined and described in the latest version of ASTM D3350. The virgin pipe material shall be evaluated using the notched constant ligament-stress (NCLS) test as specified in Section 9.5 and 5.1 of AASHTO M294 and ASTM F2306, respectively. All smooth baffle and weir plates shall be high density polyethylene.

## INSTALLATION

Installation shall be in accordance with the Hancor published installation guidelines, utilizing a Class I (ASTM D2321) structural backfill material or flowable fill (CLSM—Controlled Low Strength Material). Contact your local Hancor representative or visit [www.hancor.com](http://www.hancor.com) for the latest installation instructions.

## PERFORMANCE

Storm Water Quality Units shall remove a minimum of 80% of the first flush total suspended solids (TSS) based on flow rates and corresponding sieve shown in Table 1. Storm Water Quality Units shall be installed “offline” to prevent re-suspension of solids in high flow situations. Offline installation shall be constructed utilizing a Hancor By-Pass structure. Flow through the unit shall be controlled by an orifice fabricated on the outlet end of the structure.

All sales of Hancor product are subject to a limited warranty and purchasers are solely responsible for installation and use of Hancor products and determining whether a product is suited for any specific needs. Please consult a full copy of Hancor's Terms and Conditions for Sale for further details.

## DIRECT CONTACT Customer Service

888-FOR PIPE (367-7473)  
Fax 888-FAX PIPE (329-7473) 24 hours a day

## ELECTRONIC MEDIA Web Site

Find market- and application-specific information and the latest industry news at our On-Line Pipeline – [www.hancor.com](http://www.hancor.com)

Hancor® is a registered trademark of Hancor, Inc.  
LandSaver™ is a registered trademark of StormTech, LLC.  
Nyloplast® is a registered trademark of Nyloplast.  
© 2007 Hancor, Inc. 1323  
#1172/0907

### Series 35—Flanged Check Valve

#### Materials of Construction

- Pure Gum Rubber, Neoprene, Chlorobutyl, Buna-N, Polyurethane  
Hypalon, Viton, EPDM, Food Grade
- Galvanized Steel, Stainless Steel

The Tideflex® Technologies Series 35 Check Valve is manufactured identically to the Tideflex® Check Valve, with the addition of an integral elastomer flange as part of the valve. The standard flange size drilling conforms to ANSI B16.5 and ANSI B16.47, Class 150 standards. All other domestic and international standards, as well as customer specified flange dimensions, are available. The Series 35 Check Valve is furnished complete with 3/8” thick steel back-up rings for installation.

In some applications and installations, a slip-over pipe Check Valve is not feasible because of an existing flange in the piping system or an existing flange cemented in the outfall piping system vault. In these cases, the Series 35 Check Valve is the solution.

The Tideflex® Technologies Series 35 Check Valve is simple in design, with only one part - the all-rubber duck bill check sleeve. There are no seats or interference fits to corrode or freeze valve operation, making the Series 35 virtually maintenance free. The Series 35 seals completely around solids, making it ideal for fly ash, raw sewage, sludge, lime, mining slurries, and many other abrasive and corrosive slurries.

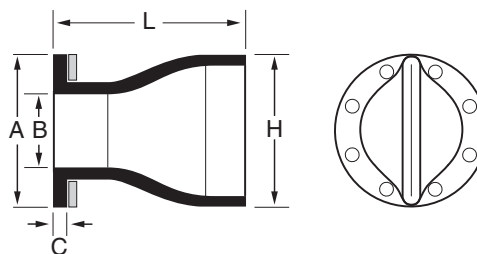
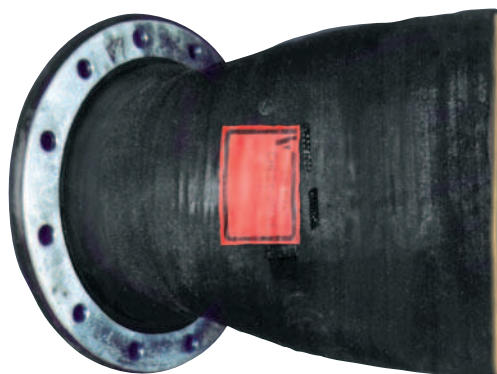

#### DIMENSIONS SERIES 35

ANSI FLANGE SIZE	FLANGE O.D. A	INSIDE DIAMETER B	FLANGE THICKNESS C	MAXIMUM LENGTH L	MAXIMUM HEIGHT H
1/2"	3-1/2"	1/2"	1/2"	2-1/2"	1-1/4"
3/4"	3-7/8"	3/4"	1/2"	3"	1-1/2"
1"	4-1/4"	1"	1/2"	3"	1-1/2"
1-1/4"	4-5/8"	1-1/4"	1/2"	5-3/4"	2-3/4"
1-1/2"	5"	1-1/2"	1/2"	5-3/4"	3-5/8"
2"	6"	2"	1/2"	5-3/4"	3-5/8"
2-1/2"	7"	2-1/2"	1/2"	7-1/2"	4-5/8"
3"	7-1/2"	3"	3/4"	9"	5-3/8"
4"	9"	4"	3/4"	12"	7"
5"	10"	5"	3/4"	15-1/4"	8-7/8"
6"	11"	6"	1"	15-5/8"	10-3/8"
8"	13-1/2"	8"	1"	16-1/2"	13"
10"	16"	10"	1"	21-1/2"	16-7/8"
12"	19"	12"	1"	26-1/2"	20-1/8"
14"	21"	14"	1"	25-3/8"	21-1/2"
16"	23-1/2"	15-1/4"	1"	27-1/2"	22-1/4"
18"	25"	17-1/2"	1-1/2"	30"	26-3/4"
20"	27-1/2"	19-1/4"	1-1/2"	32-3/8"	32-1/2"
22"	29-1/2"	21-1/4"	1-1/2"	35-1/2"	32-1/2"
24"	32"	24"	1-1/2"	40-1/2"	37"
30"	38-3/4"	29-1/2"	1-1/2"	43"	49-1/2"
32"	41-3/4"	32"	1-1/2"	51-3/8"	46"
36"	46"	35-1/4"	1-1/2"	54"	58"
42"	53"	42"	2"	60-1/4"	72-1/2"
48"	59-1/2"	48"	2"	59"	77-1/2"
60"	73"	60"	2"	72"	96-3/4"
72"	86-1/2"	72"	2"	95"	102"
84"	99-3/4"	84"	2"	92"	110-1/2"



● TECH LIGHTING "KONIAL 17 METAL" SCONCE  
HEIGHT: 17"  
1800 LUMENS



● TECH LIGHTING "BOWMAN 6" SCONCE  
HEIGHT: 6"  
1163 LUMENS  
*(for homeowner deck at door)*

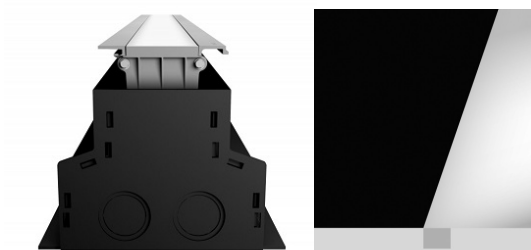

● LUMENPULSE "INGROUND" IN-GRADE  
1", 2", 3" OR 4" SECTIONS  
ASYMMETRIC WALLWASH OPTIC  
3404 LUMENS  
*for illuminating frosted balcony panels*



● ECOSENSE "RISE F080" FLOODLIGHT (L)  
SPOT & FLOOD BEAM ANGLES  
745 LUMENS  
*for grazing columns (down)*

● ECOSENSE "TROV L50" LINEAR EXTERIOR (R)  
12", 48" SECTIONS  
3019 LUMENS  
*for uplighting cornices, mount to ledge*

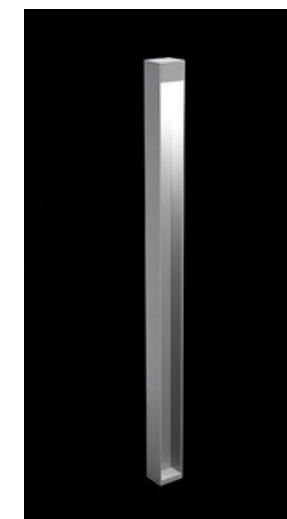
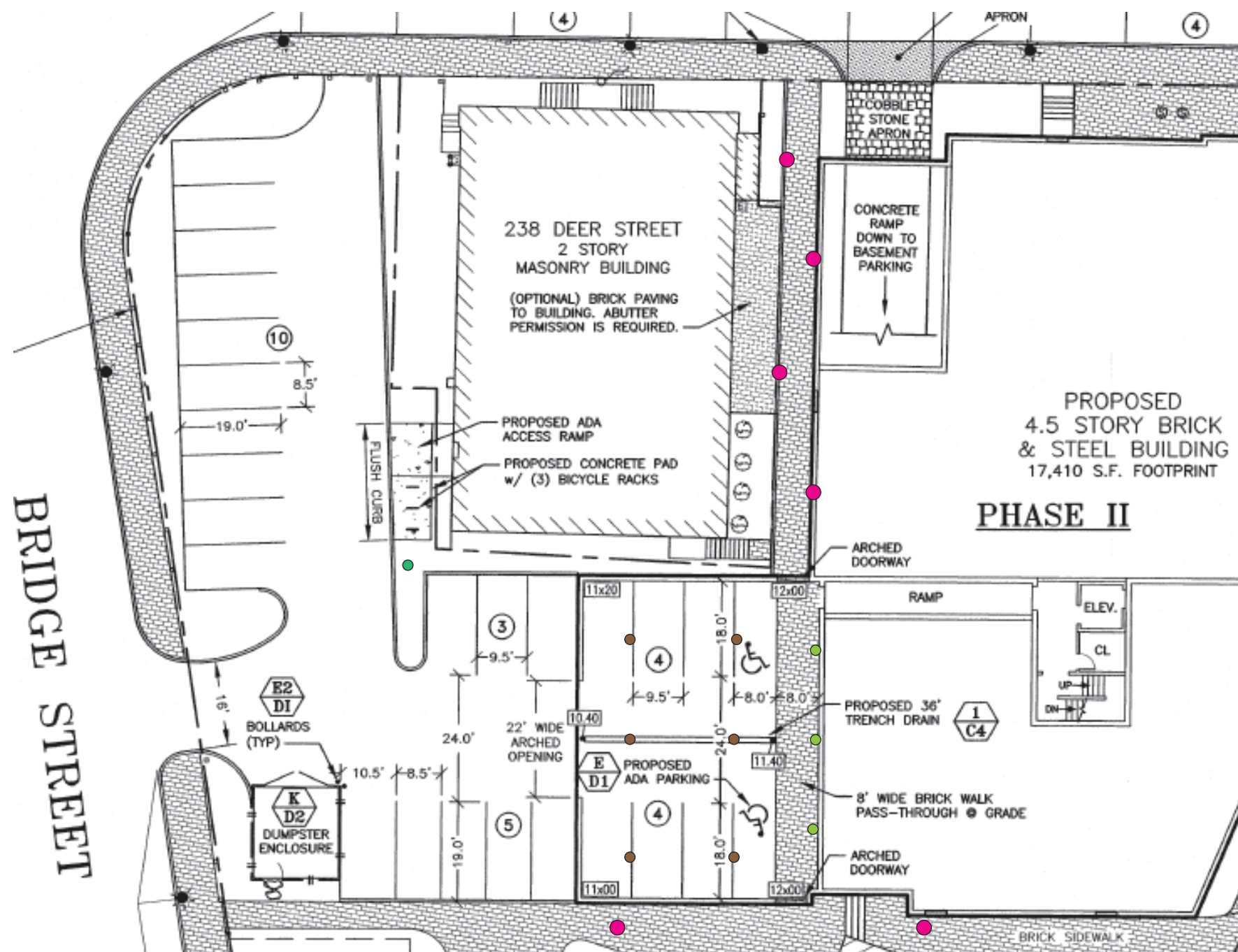

● DESIGNPLAN "KLEIN 900" BOLLARD  
HEIGHT: 35.4"  
78 LUMENS



● TECH LIGHTING "CIRQUE LARGE OUTDOOR CEILING"  
DIAMETER: 11"  
1143 LUMENS



● V2 LIGHTING "CORE 300 LX" SCONCE  
HEIGHT: 12.2"  
UP TO 3000 LUMENS



● SISTEMALUX "SLOT ROUND" POLE  
HEIGHT: 12.6"  
2788 LUMENS PER LAMP



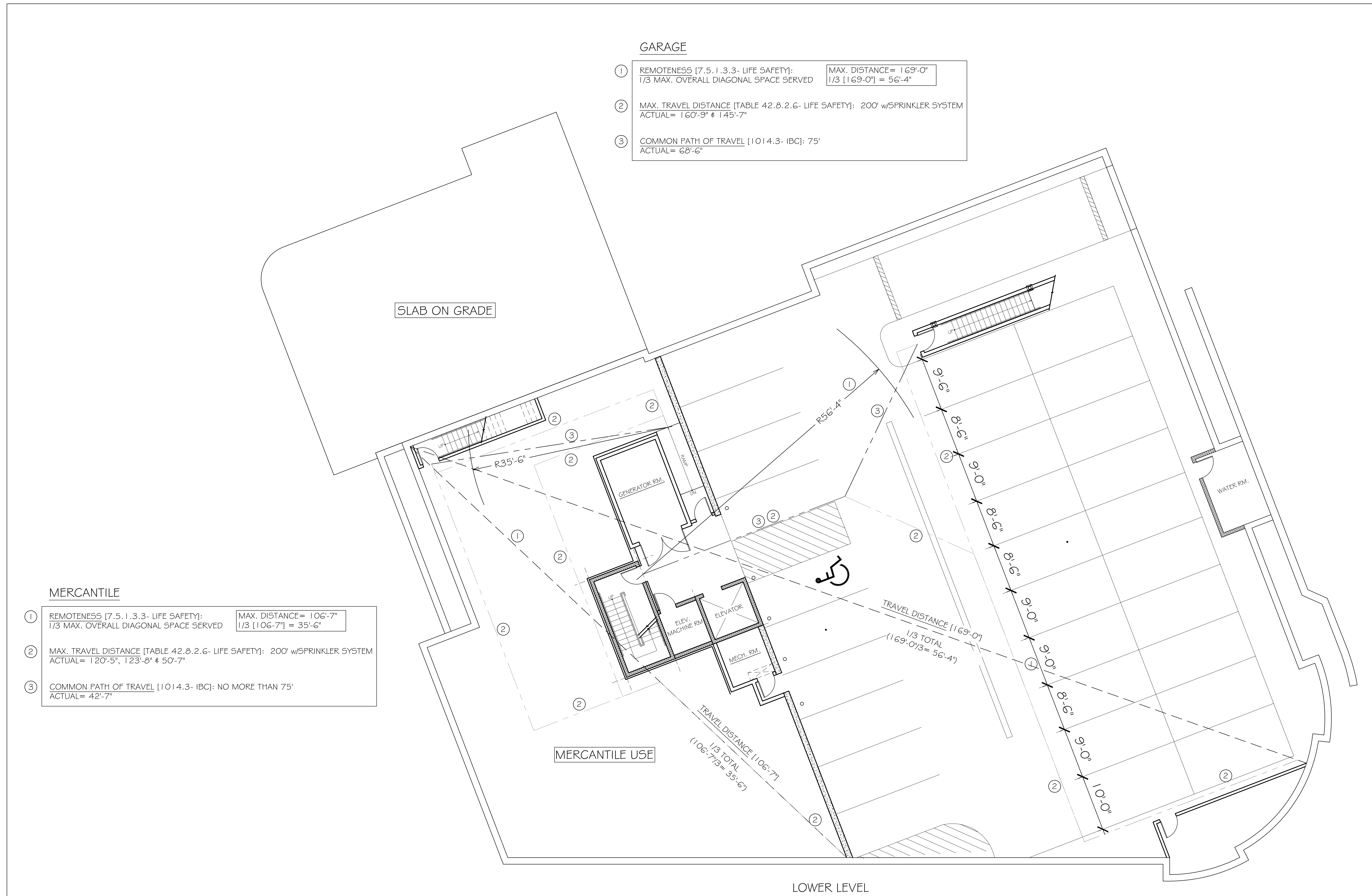

**GARAGE**

- ① REMOTENESS [7.5.1.3.3- LIFE SAFETY]:  
1/3 MAX. OVERALL DIAGONAL SPACE SERVED      MAX. DISTANCE= 169'-0"  
1/3 [169-0"] = 56'-4"
- ② MAX. TRAVEL DISTANCE [TABLE 42.8.2.6- LIFE SAFETY]: 200' w/SPRINKLER SYSTEM  
ACTUAL= 160'-9" & 145'-7"
- ③ COMMON PATH OF TRAVEL [1014.3- IBC]: 75'  
ACTUAL= 68'-6"

**MERCANTILE**

- ① REMOTENESS [7.5.1.3.3- LIFE SAFETY]:  
1/3 MAX. OVERALL DIAGONAL SPACE SERVED      MAX. DISTANCE= 106'-7"  
1/3 [106-7"] = 35'-6"
- ② MAX. TRAVEL DISTANCE [TABLE 42.8.2.6- LIFE SAFETY]: 200' w/SPRINKLER SYSTEM  
ACTUAL= 120'-5", 123'-8" & 50'-7"
- ③ COMMON PATH OF TRAVEL [1014.3- IBC]: NO MORE THAN 75'  
ACTUAL= 42'-7"

LOWER LEVEL: EGRESS REQUIREMENTS  
1/8" = 1'-0"

REVISIONS:



36 Maplewood Avenue  
Portsmouth, NH 03801  
PH: 603.766.3760

46-64 Maplewood  
Avenue  
Portsmouth, NH

TITLE:  
LOWER LEVEL  
EGRESS  
REQUIREMENTS

SCALE: AS NOTED  
DRAWN BY: SOMMA  
CHECKED BY:  
PROJECT NO.: -  
DATE: JANUARY 30, 2018

**EGRESS**

REVISIONS:



SOMMA

36 Maplewood Avenue  
Portsmouth, NH 03801  
Ph: 603.766.3760

46-64 MAPLEWOOD AVE.  
36 MAPLEWOOD AVENUE  
PORTSMOUTH, NH 03801

TITLE:  
BUILDING OPENING  
CALCULATIONS

SCALE: AS NOTED  
DRAWN BY: SOMMA  
CHECKED BY:  
PROJECT NO.: -  
DATE: DECEMBER 19, 2017



BRIDGE STREET ELEVATION

N.T.S.

REVISIONS:



DEER STREET ELEVATION  
N.T.S.



SOMMA

36 Maplewood Avenue  
Portsmouth, NH 03801  
Ph: 603.766.3760

46-64 MAPLEWOOD AVE.  
36 MAPLEWOOD AVENUE  
PORTSMOUTH, NH 03801

TITLE:  
BUILDING OPENING  
CALCULATIONS

SCALE: AS NOTED  
DRAWN BY: SOMMA  
CHECKED BY:  
PROJECT NO.: -  
DATE: DECEMBER 19, 2017

REVISIONS:



SOMMA

36 Maplewood Avenue  
Portsmouth, NH 03801  
Ph: 603.766.3760

46-64 MAPLEWOOD AVE.  
36 MAPLEWOOD AVENUE  
PORTSMOUTH, NH 03801

TITLE:  
BUILDING OPENING CALCULATIONS

SCALE: AS NOTED  
DRAWN BY: SOMMA  
CHECKED BY:  
PROJECT NO.: -  
DATE: DECEMBER 19, 2017

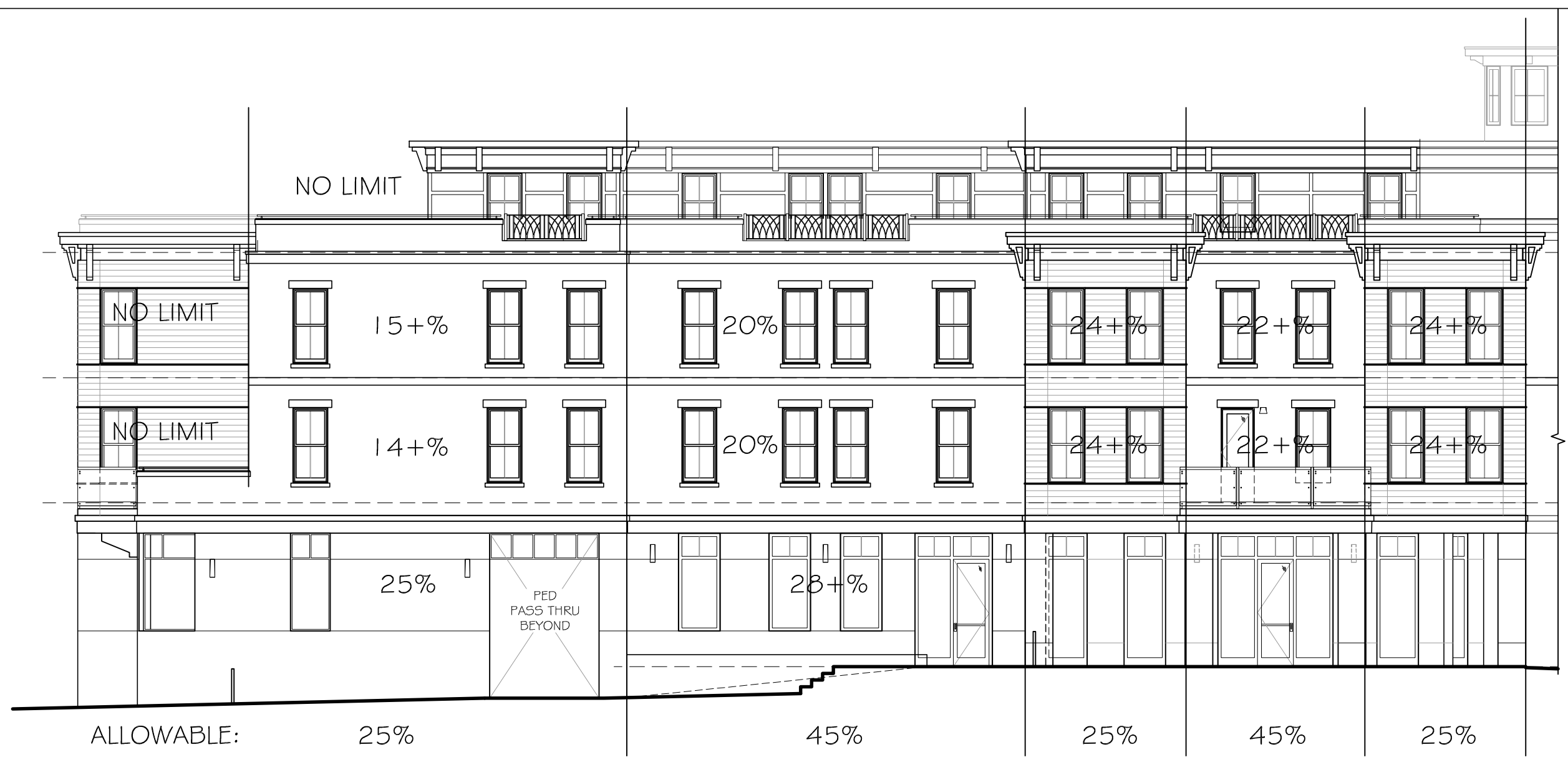

PEDESTRIAN WAY ELEVATION

N.T.S.