

22-110



N O R T H

M I L L

P O N D

NOTES:

1. PARCEL IS LOCATED IN THE CENTRAL BUSINESS DISTRICT.
2. PARCEL IMPROVEMENTS ARE COMPLETELY WITHIN ZONE C OF THE FLOOD HAZARD SYSTEM.
3. OFFSET DISTANCES ARE PERPENDICULAR TO PROPERTY LINES UNLESS OTHERWISE NOTED.
4. STEPS TO EACH UNIT ARE LCA FOR THAT UNIT.
5. ALL UNITS ARE SERVED WITH UNDERGROUND ELECTRICITY, TELEPHONE, CABLE TV, & FIRE ALARM.
6. SITE PROVIDES 120 PARKING SPACES.
7. SEE CONVEYANCE TO NOBLE'S ISLAND REALTY DEVELOPMENT RCRD 2433-0867.
8. SEE RCRD D-9888 & "LOT LINE ELIMINATION PLAN FOR NOBLE'S ISLAND CONDOMINIUMS..." JAN. 20, 1983.
9. SEE RCRD D-11033. THIS PLAN UPDATES THAT PLAN. UNITS ARE RE-NUMBERED.
10. SEE RCRD 2430-1473. EASEMENTS REFERENCED THEREIN (RCRD 2303-1120) ARE ELIMINATED BY VIRTUE OF THE LOT LINE ELIMINATION SHOWN HEREON. THIS PLAN SHOWS CONFORMANCE TO COVENANTS REFERENCED THEREIN (RCRD. 2332-1847).

REMOVE AND REPLACE EXISTING 1ST FLOOR EXTERIOR DECK

BUILDING B

REMOVE AND REPLACE EXISTING 1ST FLOOR EXTERIOR DECK

BUILDING C

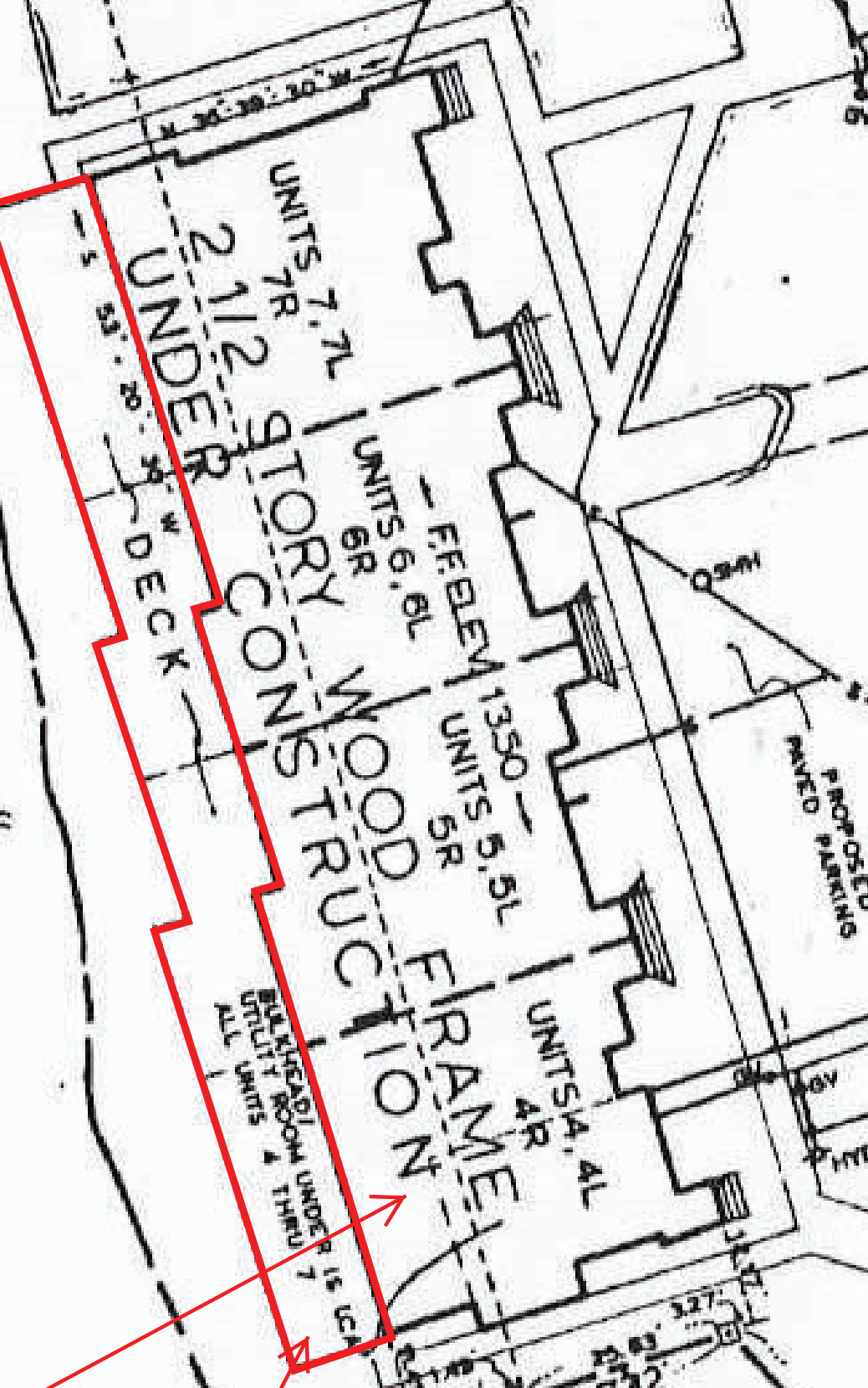
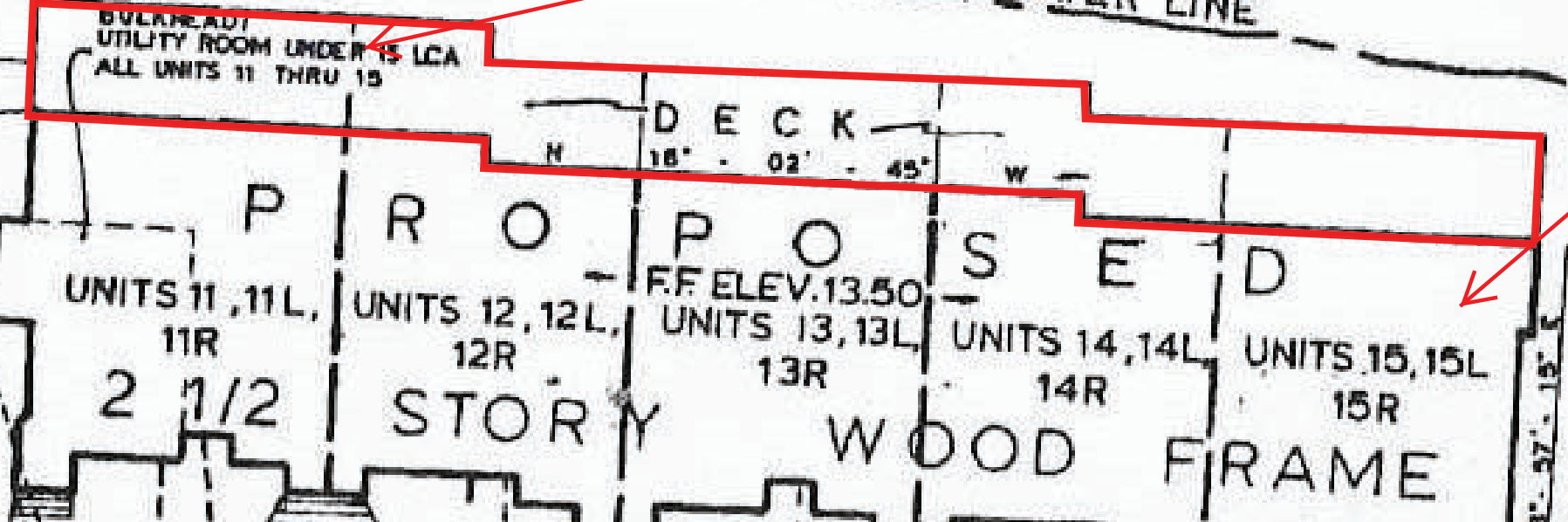
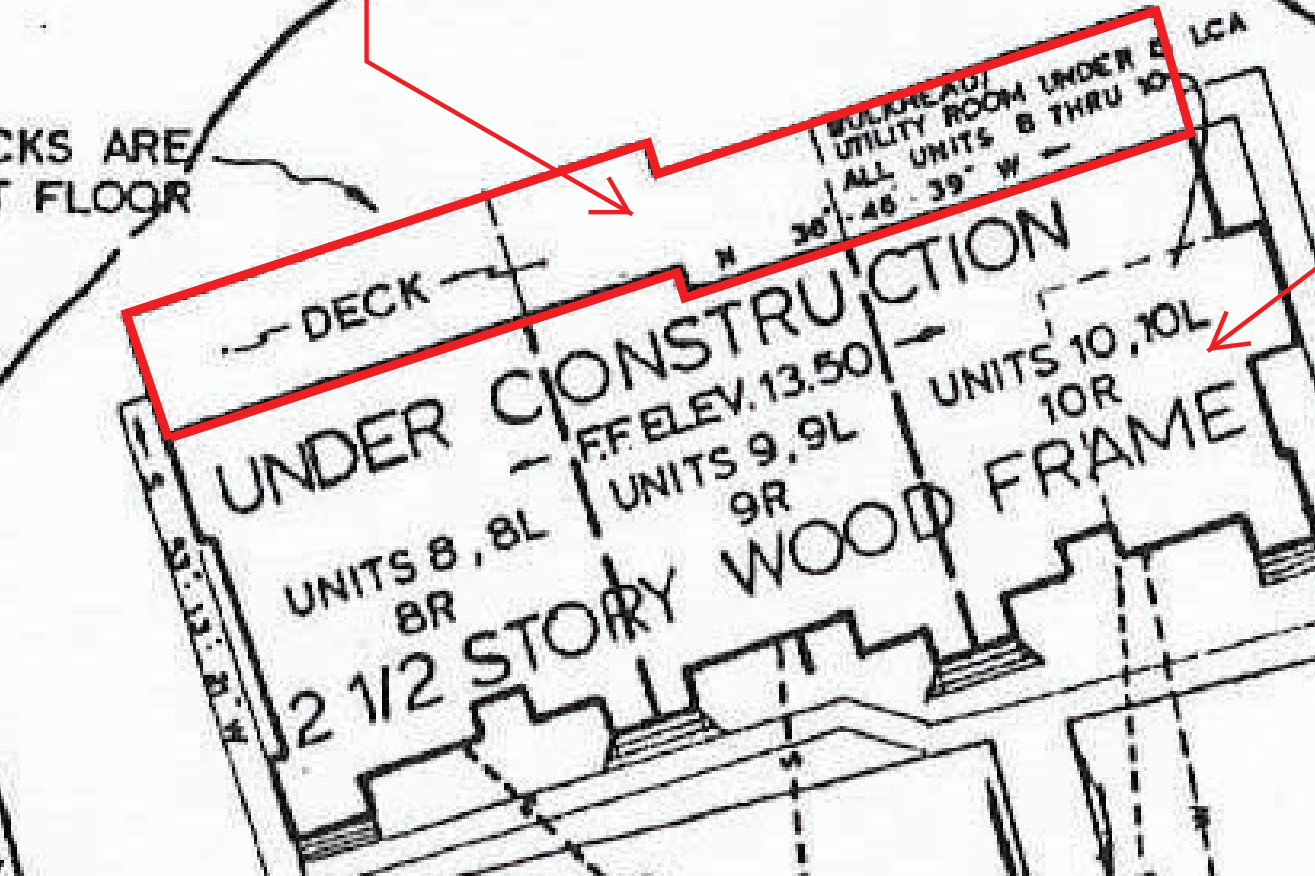

TOTAL AREA = 105,356 s.f.
 COMMON AREA = 73,537 s.f.
 EXPANDABLE AREA = 8,345 s.f.±

LEGEND

- CB CATCH BASIN
- CB BOX CURB BOX
- DRAIN
- CA CENTRAL ANGLE
- GV GATE VALVE
- HYD HYDRANT
- LCA LENGTH OF CURVE
- LC LIMITED COMMON AREA
- R RADIUS
- SMH SEWER MANHOLE
- W WATER
- WSO WATER SHUT OFF
- UOE UNDERGROUND ELECTRIC
- FF FIRST FLOOR
- TBM TEMPORARY BENCH MARK

BUILDING A

REMOVE AND REPLACE EXISTING 1ST FLOOR EXTERIOR DECK

"EXPANDABLE" AREA 8,345 s.f.±

NOTE: NOBLE EASTERLY & SOUTHERLY PROPERTY LINES SHOWN HEREON AS THEY APPEAR ON NHD&W MARKET ST. RIGHT OF WAY PLANS. PROPERTY NOT SURVEYED AT THIS TIME.

For Recording Purposes Only - Not a sub-division.

D-11709 Sheet 1 of 8

SITE PLAN FOR NOBLE'S ISLAND CONDOMINIUMS
 MARKET STREET
 COUNTY OF ROCKINGHAM
 PORTSMOUTH, N.H.

I CERTIFY THAT TO THE BEST OF MY KNOWLEDGE THIS PLAN IS ACCURATE AND IS IN COMPLIANCE WITH THE PROVISIONS OF NEW HAMPSHIRE RSA 356 B:20(i) AND THAT ALL UTILITIES EXIST AS SHOWN HEREON.

Richard P. Millette
 LICENSED LAND SURVEYOR
 2-23-83

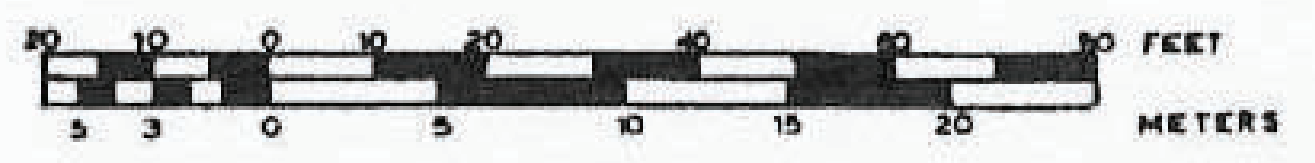

SCALE: 1" = 20'

JANUARY 20, 1983

RICHARD P. MILLETTE AND ASSOC. THE HILL PORTSMOUTH, NH 0380'

-81147-

PORTSMOUTH PLANNING BOARD
Edward Clarke 2-25-83

20089 500 Market St / Portsmouth, NH
Photographs taken by Aaron Wilson, P.E.

DSC00544 3/26/2020 9:03:36 AM



DSC00545 3/26/2020 9:03:42 AM



DSC00551 3/26/2020 9:05:16 AM



DSC00552 3/26/2020 9:05:24 AM



DSC00553 3/26/2020 9:05:32 AM



DSC00558 3/26/2020 9:08:02 AM



20089 500 Market St / Portsmouth, NH
Photographs taken by Aaron Wilson, P.E.

DSC00559 3/26/2020 9:08:08 AM



DSC00560 3/26/2020 9:08:22 AM



20089 14 9/17/2020 2:13:42 PM



20089 18 9/17/2020 2:23:42 PM



20089 20 9/17/2020 2:26:14 PM



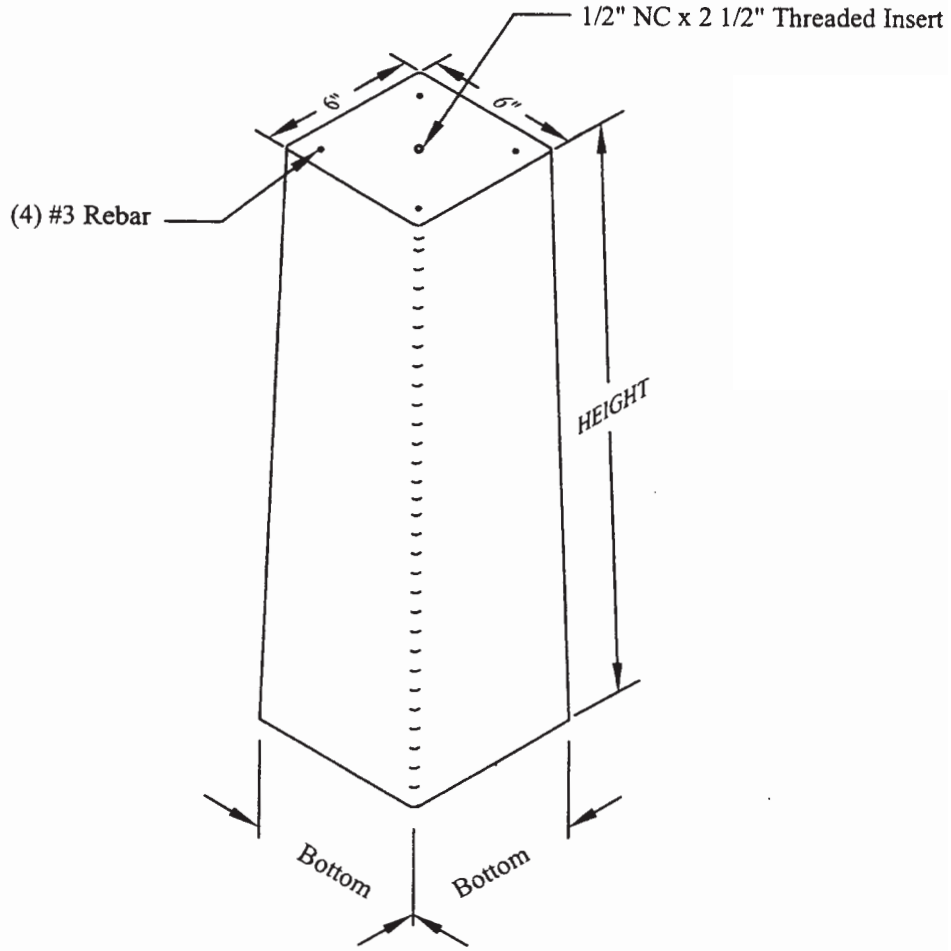

ELEVATION

Height (Feet)	Bottom (Inches)	Item #	Weight
4'-0"	9"	21740	230 lbs.
5'-0"	10"	21750	340 lbs.
6'-0"	11"	21760	450 lbs.

DESIGN NOTES:

- 1) Concrete Mix Design is 4,000 PSI standard at 28 days, Type 3 Cement.
- 2) Reinforcing Steel ASTM A 615, Grade 60
- 2) Smooth Finish on all exposed surfaces.

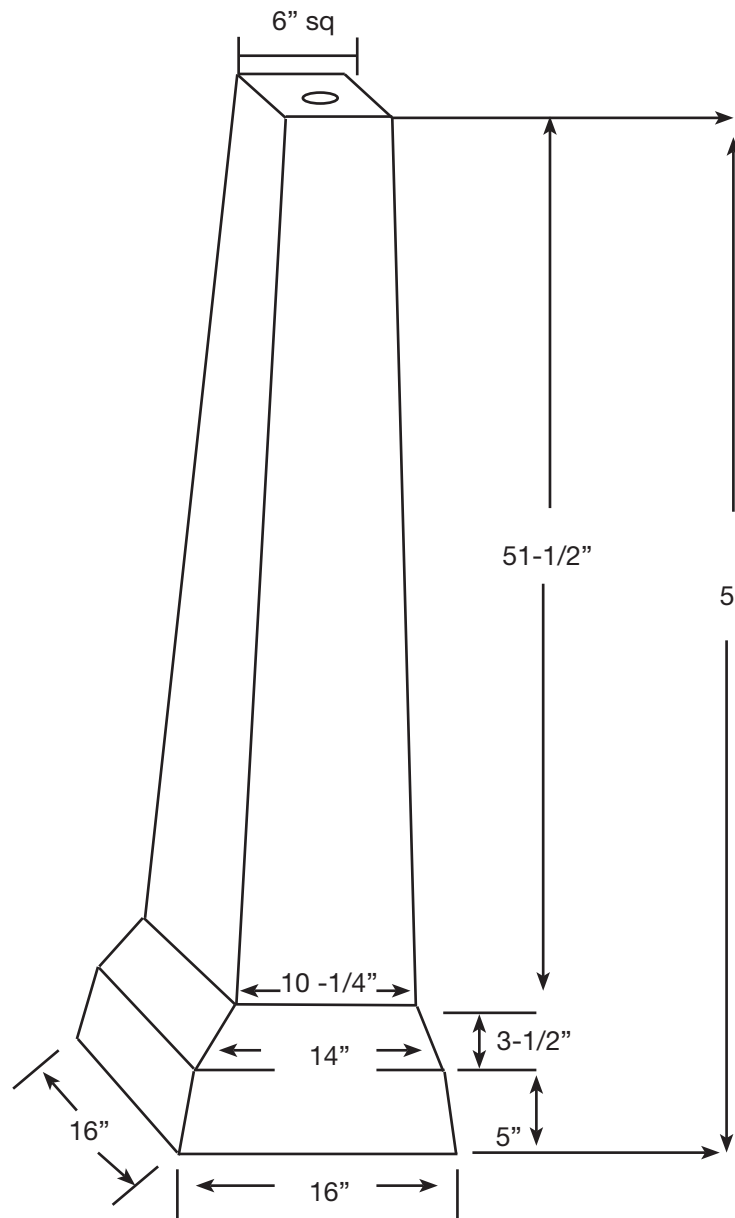

Design Notes:

1. Concrete Mix Design is 5,000 PSI standard at 28 days, Type 3 Cement.
2. Reinforced Steel ASTM A 615, Grade 60.
3. Smooth Finish on all exposed surfaces.