



Wyskiel,
Boc,
Tillinghast
& Bolduc, P.A.
Attorneys at Law

*Michael J. Bolduc

**Thomas G. Ferrini

*William R. Phipps

***D. Lance Tillinghast

*Christopher A. Wyskiel

William E. Boc - Retired

* also admitted in Maine

** also admitted in MA & VT

*** also admitted in MA, ME & VT

January 22, 2025

ORIGINAL HAND DELIVERED

And

Copy Uploaded as Attachment to Online Application Submittal

City of Portsmouth
Zoning Board of Adjustment
c/o Planning Department
1 Junkins Avenue, 3rd Floor
Portsmouth, NH 03801

RE: Application for Variance for Minor Sideline Setback Relief
By Paula J. Reid, Trustee of the Paula J. Reid 2003 Revocable Trust
410 Richards Avenue
Tax Map 112, Lot 10
General Residence A ("GRA") zone

Dear Board Members:

This office represents Paula J. Reid, Trustee of the Paula J. Reid Revocable Trust, owner of the above referenced property. See Landowner Letter of Authorization Exhibit A. This letter supplements the online Land Use Application form submitted by the undersigned on Paula's behalf.

By Notice of Decision dated December 26, 2023, Portsmouth Case LU-23-198 (copy attached with Findings of Fact as Exhibit B), the Portsmouth ZBA granted variances to Paula Reid to tear down an existing dilapidated garage on her property in order to build a new one conforming to the dimensional requirement relief granted by the approved variances.

The variances granted allowed building a longer and slightly higher pitched garage, maintaining a pre-existing 3.5 foot right side yard setback. The variances were needed to lengthen the garage and keep an existing 3.5 foot right yard setback (where 10 feet is required) and slightly enlarge building coverage.

Excavation, foundation pouring and subsequent construction were all planned, measured and laid out intending to conform to the granted variances, specifically the 3.5 right side yard setback. When the foundation was completed and garage construction underway, a City required foundation certification was completed by McEneaney Survey Associates of New England, the same surveyor who surveyed the lot and submitted plans for the variance applications. McEneaney's January 7, 2025 foundation certificate survey (copy attached as Exhibit C) shows the front corner of the garage encroaching four inches into the variance allowed 3.5 foot right yard setback. It shows the rear corner of the garage encroaching one inch into the same 3.5 foot right yard setback.

The Applicant filed an application for an Equitable Waiver for Dimensional Requirement for zoning relief from the above described/documented facts. If an Equitable Waiver is not granted, action on this variance application is appropriate.

Specific Variance Request

The variance previously granted by the Zoning Board of Adjustment is requested to be amended (or reissued as new) to specifically authorized relief from Section 10.521 Table of Dimensional Standards to allow:

- (a) Side yard setback relief to allow completion of construction of Applicant's substantially completed garage, modifying the previously granted setback relief granted by the ZBA's December 26, 2023 Notice of Decision, Case #LU-23-198, to the side yard setbacks confirmed by the McEneaney Survey Associates of New England Foundation Certification Plan dated January 7, 2025.
- (b) Building coverage relief to allow the above which increases existing 28.3% building coverage to 29.7% where a maximum building coverage of 25% is required for the GRA Zone.

Variance Criteria Addressed

But for minor (inches) foundation location of the garage, Applicant's contractors substantially complied with the ZBA's Exhibit B December 26, 2023 Notice of Decision. See photos attached as Exhibit E evidencing substantial completion of subject garage. No Exhibit D is attached to this application. Further work on the garage has ceased pending further ZBA action.

Justification for the variance remains exactly the same as explained by the undersigned's November 29, 2023 seven page letter with attached and referenced exhibits (all resubmitted herewith as numbered 1-10, as identified in said letter). The minor few inches of side yard setback encroachment do not render invalid the justification as explained in Applicant's original application, granted by the ZBA by its December 26, 2023 Notice of Decision (which acknowledged the Board's finding that a variance from Section 10.321 as originally requested and addressed in said November 29, 2023 letter is not required to proceed with Applicant's garage plans.

This variance application is unnecessary if the ZBA grants Applicant's Equitable Waiver from Dimensional Requirement. If an equitable waiver is not granted however, the variances requested hereby are reasonable and should be granted.

Sincerely

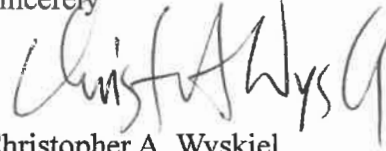
A handwritten signature in black ink, appearing to read "Christopher A. Wyskiel". The signature is written in a cursive style with some loops and flourishes.

Christopher A. Wyskiel

CAW/lew

Enclosures

cc: Paula J. Reid

City of Portsmouth
Zoning Board of Adjustment
1 Junkins Avenue, 3rd Floor
Portsmouth, NH 03801

LETTER OF AUTHORIZATION

Re: ZBA Application(s) re: 410 Richards Avenue, Portsmouth, NH
Owners: Paula J. Reid, Trustee of the Paula J. Reid 2003 Revocable Trust

Dear Sir/Madam:

Paula J. Reid, individually and as Trustee of the Paula J. Reid 2003 Revocable Trust, authorize my attorney, Christopher A. Wyskiel of Wyskiel, Boc, Tillinghast & Bolduc, P.A. to represent me, individually and in my landowning trustee capacity, before the Zoning Board of Adjustment regarding applications for Equitable Waiver of Developmental Requirements and/or an amended variance for the above referenced property.

Sincerely,

Dated: January 17, 2025



Paula J. Reid, Individually and as Trustee
of the Paula J. Reid 2003 Revocable Trust

Exh. A



CITY OF PORTSMOUTH

Planning Department
1 Junkins Avenue
Portsmouth, New
Hampshire 03801
(603) 610-7216

ZONING BOARD OF ADJUSTMENT

December 26, 2023

Paula J. Reid 2003 Revocable Trust
410 Richards Avenue
Portsmouth, New Hampshire 03801

RE: Board of Adjustment request for property located at 410 Richards Avenue (LU-23-198)

Dear Property Owner:

The Zoning Board of Adjustment, at its regularly scheduled meeting of **Tuesday, December 19, 2023**, considered your application for demolishing and removing the existing detached garage and constructing a new detached garage and associated drainage improvements, which requires the following: 1) Variance from Section 10.521 to permit a) 3.5 foot right side yard where 10 feet is required, and b) 30% building coverage where 25% is the maximum allowed; and 2) Variance from Section 10.321 to allow a nonconforming structure or building to be extended, reconstructed or enlarged without conforming to the requirements of the Ordinance. Said property is shown on Assessor Map 112 Lot 10 and lies within the General Residence A (GRA) District. As a result of said consideration, the Board voted to **approve** the requested variances from Section 10.521 and acknowledge that the request does not require relief from Section 10.321.

The Board's decision may be appealed up to thirty (30) days after the vote. Any action taken by the applicant pursuant to the Board's decision during this appeal period shall be at the applicant's risk. Please contact the Planning Department for more details about the appeals process.

Approvals may also be required from other City Commissions or Boards. Once all required approvals have been received, applicant is responsible for applying for and securing a building permit from the Inspection Department prior to starting any project work.

This approval shall expire unless a building permit is issued within a period of two (2) years from the date granted unless an extension is granted in accordance with Section 10.236 of the Zoning Ordinance.

The Findings of Fact associated with this decision are available: attached here or as an attachment in the Viewpoint project record associated with this application and on the Zoning Board of Adjustment Meeting website:

<https://www.cityofportsmouth.com/planportsmouth/zoning-board-adjustment/zoning-board-adjustment-archived-meetings-and-material>

Exh B

The minutes and audio recording of this meeting are available by contacting the Planning Department.

Very truly yours,

Phyllis Eldridge

Phyllis Eldridge, Chair of the Zoning Board of Adjustment

cc: Shanti Wolph, Chief Building Inspector

Rosann Maurice-Lentz, City Assessor

Christopher A Wyskiel, Attorney, Wyskiel, Boc, Tillinghast and Bolduc P.A.

Exh. B

Findings of Fact | Variance

City of Portsmouth Zoning Board of Adjustment

Date: 12-19-2023

Property Address: 410 Richards Avenue

Application #: LU-23-198

Decision: **Grant**

Findings of Fact:

Effective August 23, 2022, amended RSA 676:3, It now reads as follows: The local land use board shall issue a final written decision which either approves or disapproves an application for a local permit and make a copy of the decision available to the applicant. **The decision shall include specific written findings of fact that support the decision. Failure of the board to make specific written findings of fact supporting a disapproval shall be grounds for automatic reversal and remand by the superior court upon appeal, in accordance with the time periods set forth in RSA 677:5 or RSA 677:15, unless the court determines that there are other factors warranting the disapproval.** If the application is not approved, the board shall provide the applicant with written reasons for the disapproval. If the application is approved with conditions, the board shall include in the written decision a detailed description of all conditions necessary to obtain final approval.

The proposed application meets/does not meet the following purposes for granting a Variance:

Section 10.233 Variance Evaluation Criteria	Finding (Meets Criteria)	Relevant Facts
10.233.21 Granting the variance would not be contrary to the public interest.	YES	<ul style="list-style-type: none"> It is in the public interest to deal with drainage, given the climate changes.
10.233.22 Granting the variance would observe the spirit of the Ordinance.	YES	<ul style="list-style-type: none"> The Board didn't think the minor variation in lot coverage was outside of it and that adding a garage is like what every other property in the neighborhood did.
10.233.23 Granting the variance would do substantial justice.	YES	<ul style="list-style-type: none"> The property owner will avoid an issue that has arisen and there is no contrary interest in preserving the zoning ordinance for the property without the variance granted.
10.233.24 Granting the variance would not diminish the values of surrounding properties.	YES	<ul style="list-style-type: none"> The neighbor has said it is a fine change and there is no evidence that it will diminish anyone's property value in the immediate area.

Exh. B

<p>10.233.25 Literal enforcement of the provisions of the Ordinance would result in an unnecessary hardship.</p> <p>(a) The property has special Conditions that distinguish it from other properties in the area. AND (b) Owing to these special conditions, a fair and substantial relationship does not exist between the general public purposes of the Ordinance provision and the specific application of that provision to the property; and the proposed use is a reasonable one. OR Owing to these special conditions, the property cannot be reasonably used in strict conformance with the Ordinance, and a variance is therefore necessary to enable a reasonable use of it.</p>	<p>YES</p>	<ul style="list-style-type: none"> The property has special conditions of drainage issues and the garage is a hazard because the walls aren't straight, and the specific application of the ordinance provisions to the property will result in an unnecessary hardship.
--	------------	---

Exh. B

1/7/2025 16:15:47 File: M:\2467\Drawings\22-2467.dwg Layout: foundation cert

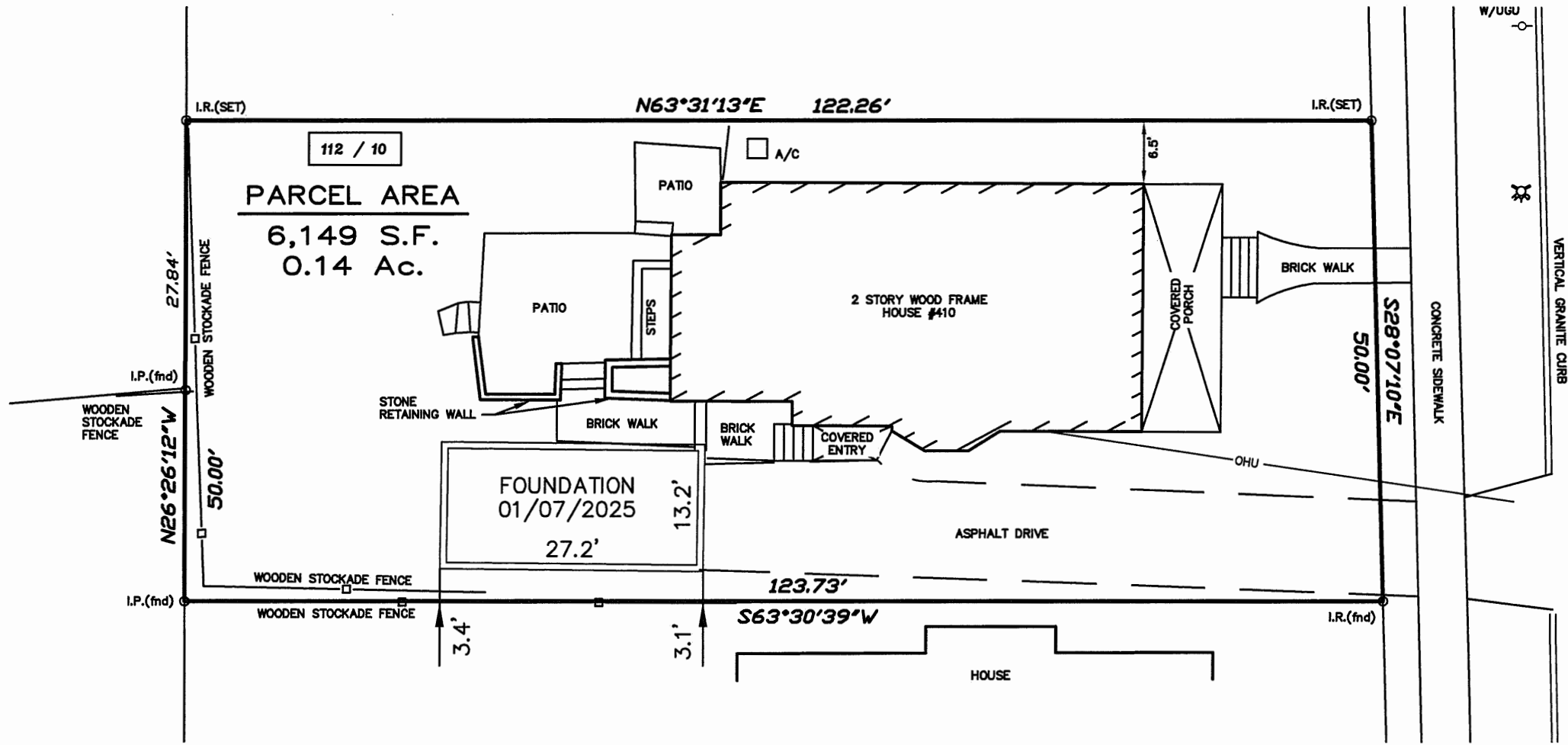

RICHARDS AVENUE
{PUBLIC R.O.W.}

FOUNDATION CERTIFICATION
FOR
PAULA J. REID 2003 REV. TRUST
410 RICHARDS AVENUE
PORTSMOUTH, NEW HAMPSHIRE

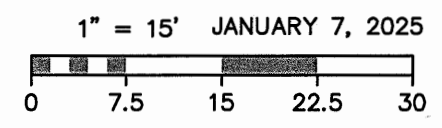

REFERENCE PLANS:

- 1.) BOUNDARY SURVEY PLAN PREPARED FOR PAULA J. REID 2003 REVOCABLE TRUST, TAX MAP 112, LOT No. 10, 410 RICHARDS AVE, CITY of PORTSMOUTH, COUNTY of ROCKINGHAM, STATE of NEW HAMPSHIRE. SCALE: 1" = 10'; DATED: OCTOBER 25, 2022; BY THIS OFFICE. NOT RECORDED.

NOTES:

- 1.) ZONING DISTRICT IS GENERAL RESIDENCE A (GRA)
- 2.) REFERENCE IS MADE TO A ZONING BOARD OF ADJUSTMENT LETTER DATED DECEMBER 26, 2023 WHICH GRANTS A VARIANCE FROM SECTION 10.521 TO PERMIT A 3.5 FOOT RIGHT SIDE YARD WHERE 10 FEET IS REQUIRED.
- 3.) THIS IS NOT A BOUNDARY SURVEY, IT IS INTENDED FOR FOUNDATION CERTIFICATION ONLY.

"I CERTIFY THAT THE FOUNDATION LOCATION SHOWN DOES NOT MEET THE INTENDED VARIANCE REQUIREMENT, AND IS LOCATED OUTSIDE THE 0.2% ANNUAL CHANCE FLOODPLAIN."

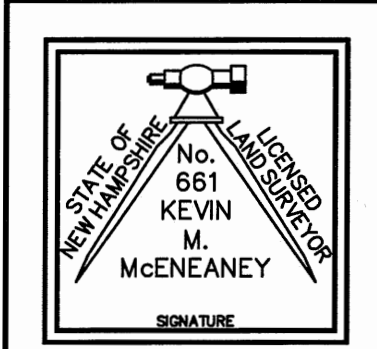

McEneaney
Survey
Associates
of NEW ENGLAND
P.O. Box 1166 - 181 WATSON ROAD
DOVER, NH 03820 (603) 742-0911



Exh. E

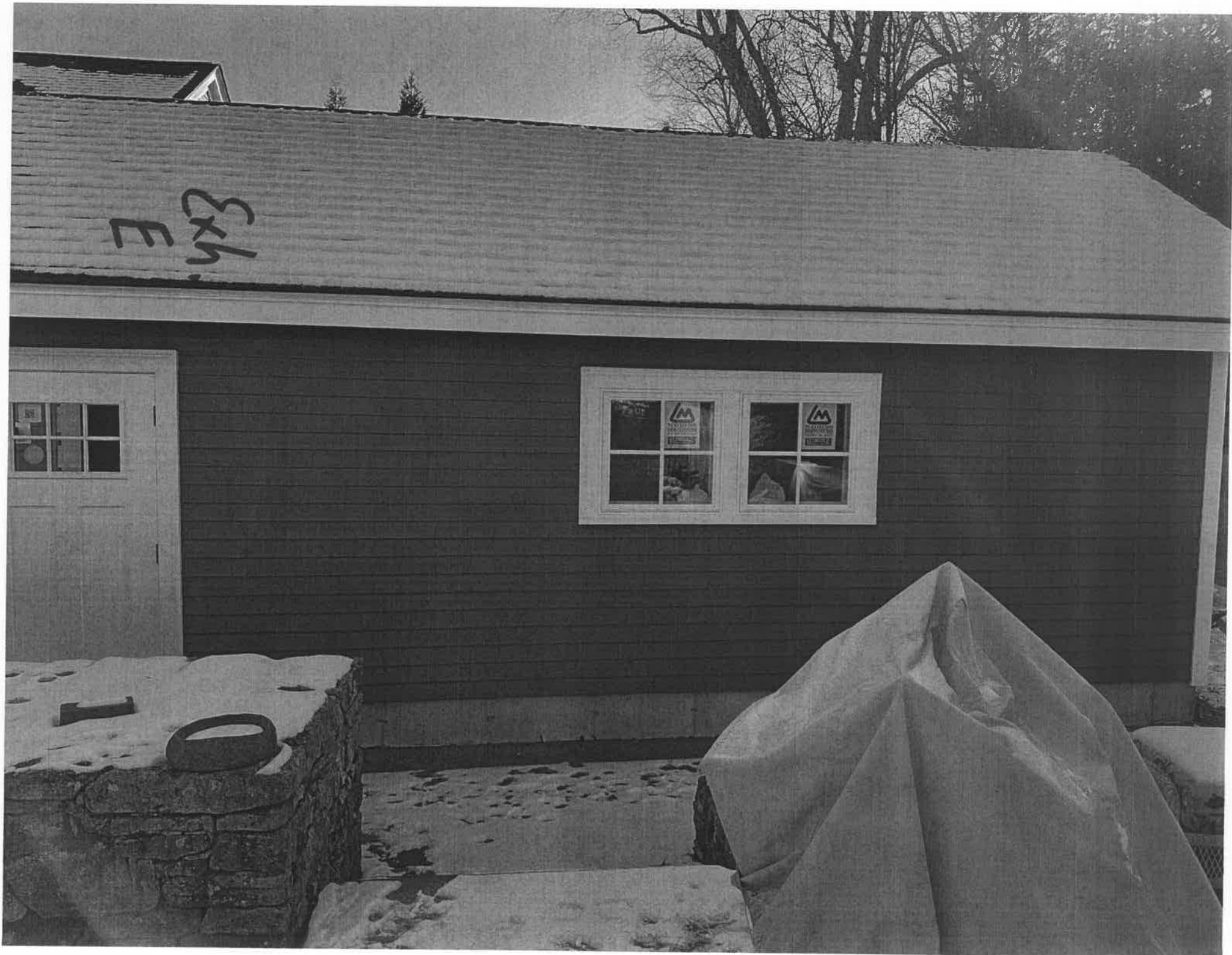

LIST OF ABUTTERS

Applicant: Paula J. Reid, Trustee of the Paula J. Reid 2003 Revocable Trust
 410 Richards Avenue, Portsmouth, NH
 Tax Map 112, Lot 10

<u>Property Address</u>	<u>Tax Map/Lot No.</u>	<u>Owner(s)</u>	<u>RCRD Deed Ref.</u>
420 Richards Avenue	Map 112, Lot 9	Amy E. Dutton Rev. Trust of 2003, Amy E. Dutton Murphy, Trustee	5225/39
390 Richards Avenue	Map 112, Lot 11	Stebbins Family Trust, John R. & Bridget M. Stebbins, Trustees	5636/563
399 Richards Avenue	Map 112, Lot 18	Barbara E. Collier Rev. Trust, Barbara E. Collier, Trustee	6315/246
409 Richards Avenue	Map 112, Lot 19	Stephen C. Buzzell Rev. Trust, Stephen C. Buzzell, Trustee, and and Jody E. Buzzell Rev. Trust, Jody E. Buzzell, Trustee	6035/840
419 Richards Avenue	Map 112, Lot 20	Thomas A. Nies Rev. Trust of 2010 and Denise M. Nies Rev. Trust of 2010, Thomas A. & Denise M. Nies, Trustees	5192/1225
295 Miller Avenue	Map 130, Lot 9	Kristen B. Mullen Rev. Living Trust, Kristen B. Mullen, Trustee	5699/1271
303 Miller Avenue	Map 130, Lot 10	The Twombly Trust, Dorothy C. Twombly, Trustee	2762/2766

Engineer/Surveyor:

Kevin M. McEneaney
 McEneaney Survey Associates of New England
 P. O. Box 681
 Dover, NH 03821

Attorney:

Christopher A. Wyskiel
 Wyskiel, Boc, Tillinghast & Bolduc, P. A.
 561 Central Avenue
 Dover, NH 03820



Wyskiel,
Boc,
Tillinghast
& Bolduc, P.A.
Attorneys at Law

*Michael J. Bolduc
**Thomas G. Ferrini
*William R. Phipps
***D. Lance Tillinghast
*Christopher A. Wyskiel
William E. Boc - Retired

* also admitted in Maine
**also admitted in MA & VT
***also admitted in MA, ME & VT

November 29, 2023

City of Portsmouth
Zoning Board of Adjustment
c/o Planning Department
1 Junkins Avenue, 3rd Floor
Portsmouth, NH 03801

RE: Variance Application for Paula J. Reid, Trustee of the Paula J. Reid 2003 Revocable Trust
410 Richards Avenue
Tax Map 112, Lot 10
General Residence A (“GRA”) zone

Dear Members of the Zoning Board of Adjustment (and Planning Dept. staff):

This office represents Paula J. Reid, Trustee of the Paula J. Reid Revocable Trust. This letter supplements the online Land Use Application form submitted by the undersigned on Paula’s behalf. It first identifies submitted exhibits, then the specific zoning ordinance sections for which variances are requested, then explains (with reference to exhibits) Paula’s garage and site redevelopment proposal and facts relevant to variance criteria to be met.

The variances are requested to facilitate Paula’s demolition of her existing dilapidated garage to accommodate additional excavation and site work to address the serious stormwater drainage problems on her downward sloping lot, and then building a modestly enlarged replacement garage of similar scale. Paula’s proposed work is reasonable. No fair and substantial relationship exists between the purposes of the dimensional requirements from which relief is sought, and their application to Paula’s property with respect to her reasonable proposed work. The facts demonstrated by this application meet all the variance criteria set out in Portsmouth’s Zoning Ordinance and N.H. statutory and common law.

Submitted Exhibits

Submitted exhibits are numbered/lettered and summarily identified below. The numbering/lettering facilitates reference to the exhibits in the explanatory text that follows.

1. Landowner Letter of Authorization

2. Existing Conditions Plan (boundary survey by McEneaney Survey Associates dated 10/25/2022)
3. New garage proposal plan (prepared by ASB Architecture with overlay to Existing Conditions Plan)
 - 3A. Enlargement of Exhibit 3's overlay on Existing Conditions Plan
 - 3B. Enlargement of Exhibit 3's Notes with existing/proposed dimensional calculations
4. October 1898 Rockingham County Registry recorded plan (original layout of lots)
- 5A. City Tax Map print of subject lot
- 5B. City Tax Map print/aerial view (arrow points to subject lot)
6. Two pictures of lot's street view and driveway showing lot's sloping topography to back yard
7. Three pictures of house showing anticipated gutter locations (recommended gutters to be confirmed by an installer not yet consulted)
8. Three pictures showing areas that flood with stormwater drainage
9. Three pictures of existing garage showing existing/abutting lot topography differences and screening/privacy fences
10. Ten pictures of neighborhood garages on Richards Avenue and Miller Avenue (in the vicinity of the subject lot)

Specific Variance Requests

The existing garage located per Exhibit 2 and pictured in Exhibits 6, 8 and 9 is a conforming use on a non-conforming lot. Explained in more detail below, Paula proposes to remove this substandard structure to accommodate site drainage work to collect and naturally absorb/treat (by rain garden) substantial on-site stormwater drainage, then reconstruct the replacement garage depicted on Exhibit 3. Because of the proposed garage new construction and proposed lengthening by five (5) feet, variances from the following Zoning Ordinance sections are requested:

1. Section 10.321 to accommodate the modest enlargement of a lawful non-conforming structure by demolition/new construction replacement not conforming to the below dimensional requirements of the GRA zone.

2. Section 10.521 Table of Dimensional Standards:
 - (a) Side yard setback relief to accommodate a five (5) foot lengthening of the existing garage's footprint by new construction located 3.5 feet from the property sideline where a 10 foot side yard setback is required in the GRA zone (existing garage is 3.5 feet from side yard property line)
 - (b) Building coverage relief to allow the above which increases existing 28.3% building coverage to 29.7% where maximum building coverage of 25% is required for the GRA zone.

Development Proposal Explained/Facts Relevant to Requested Variances

Paula's existing garage is in a state of disrepair. Renovation consistent with current building best practices is impractical. The overhead door is difficult to open. The existing garage's height and width do not accommodate replacement with new overhead garage doors, certainly not without overhead opening equipment. Its low slanted roof allows little headroom and does not best accommodate snow loading. Replacement by new construction is warranted and reasonable.

Paula's architect, Aimee Bentley, did not conduct any boring testing to verify existing foundation or footings, but slab construction is suspected. New construction could accommodate appropriate frost walls and flooring and also accommodate below described site drainage work.

The requested lengthening by five (5) feet will accommodate longer cars of present day popularity, as well as modest indoor storage (eliminating the need for an additional exterior accessory storage shed or structure).

The topography of the lot slopes from Richards Avenue downwards to the back yard. The main roof of the house pitches from the midline forward towards Richards Avenue (where drainage can be absorbed by the front yard and landscaped plantings), and toward the back yard. Dormered roofing on the driveway side and back of the house pitches much of the rear roof's rain runoff, together with runoff from the driveway and (back yard side of) garage, all into the back driveway side door entry and walkway along the existing driveway. See pictures at Exhibits 7 and 8. In rainstorms, this driveway area in front of the garage and the walkway to the house's side entry and along the side of the garage pools with water and pours into the rear yard with no good drainage absorption.

New construction will allow machinery excavation both for the new garage's foundation and underground drainage to accommodate driveway runoff and water collected from the roof by gutters on the house (see Exhibit 7 pictures) and new garage (see Exhibit 3). That collected water will funnel into underground drainage pipe(s) to a rain garden properly designed, developed and planted in the back yard corner behind the garage. This improvement cannot be

made by keeping the existing structure. Excavation for drainage and the rain garden cannot be practically done by hand. Larger machinery can't be otherwise brought into the back yard without existing garage demolition.

Continued use of the existing structure can't reasonably facilitate storm water drainage problem solutions. Continued use of the present garage isn't reasonable for present day conditions. The proposed modest lengthening is reasonable. Cars have gotten larger. Standard garages are not designed less than 24 feet (the existing is 22 feet). The slight widening (by less than one foot into back yard side) and heightening (by less than 3½ feet per zoning defined height) accommodates current building and roof trussing to meet code and typical New England snow load requirements.

Paula anticipates her new construction demolition, site improvements (foundation, drainage and rain garden), and garage construction to be in the vicinity of \$100,000.00.

Variance Criteria Addressed

Portsmouth Zoning (Section 10.233.20 and its subparts) and 10.233.31 restate the N.H. RSA 674:33, I variance criteria. N.H. case law provides further interpretive guidance. It is reasonable to grant the requested variances.

1. Granting the variance is not contrary to the public interest.

Under N.H. law, Applicants do not have an affirmative duty to show that granting the requested variance furthers the public interest. Rather, the burden is simply to show that granting it will not be contrary to the public interest. That this distinction suggests a relatively low standard was acknowledged by the N.H. Supreme Court's decision in Chester Rod and Gun Club, Inc. v Town of Chester, 152 N. H. 577 (2005). In considering this criteria, the Court recommends the ZBA consider whether the requested variance(s) would "unduly and to a marked degree" conflict with the basic premises of the Zoning Ordinance, or alter the essential character of the locality, or threaten the public health, safety or welfare. Id. at 508.

The proposed garage replacement will not alter the essential character of the locality. Tax Map prints (Exhibits 5A & B) and the pictures at Exhibit 10 show lots in the immediate vicinity of 410 Richards Avenue that have older as well as new replacement (some larger) garages in close proximity to lot lines and neighboring homes. The less than 1 foot widening (towards the middle of the lot) and modest 5 foot lengthening (for which variance relief is sought) will hardly be noticed as to size, placement and lot coverage. If anything will be noticed at all, it will be an attractive, new, functional garage, having replaced (for anyone who remembers) an old, in need of repair garage not used by the property's owner for parking a car.

The modest proposed redevelopment shown by Exhibit 3, does not threaten the public's health, safety or welfare. Demolition of the existing structure to excavate for drainage work and

an appropriate rain garden in the corner of the yard to accommodate collected stormwater drainage, improves the public health, safety and welfare. It certainly improves the subject lot. Appropriate accommodation of stormwater drainage on site helps prevent runoff to abutting properties.

2. The spirit of the ordinance is observed by granting the requested setback variances.

In considering this criteria, Courts have suggested it to be interdependent with and should be construed together with the “not contrary to the public interest” criteria. Chester Rod and Gun Club at 580. The points made above are equally relevant to this variance test.

Many lots in the GRA zone near Paula’s were originally laid out having only 50 feet of frontage and are thus non-conforming as to frontage (many as to lot size also). See Exhibit 4 (2 pages). Over time, some of these narrow lots have been combined in whole or in part to form wider lots. See Exhibits 5A & 5B. Many narrow lots non-conforming as to size and frontage still exist, and have been developed with garages, new and old. See Exhibit 10 pictures.

Portsmouth’s Zoning Ordinance 10.233.50 states that abutting properties’ dimensional requirement violations cannot be considered as factors in determining whether the spirit of the ordinance would be observed by granting an applicant’s requested variances. The spirit of the ordinance does, however, contemplate reasonable development on non-conforming lots.

For one example, Section 10.312, specifically 10.312.10, considers lots with insufficient frontage as conforming if the lot is shown on a Registry of Deeds recorded plan prior to March 21, 1966, and contains minimum zone required square footage. Paula’s lot was first shown/ created by the 1898 plan recorded as Rockingham Registry of Deeds Plan #00125. Exhibit 4. It has less than GRA zone required frontage. It does not meet the zone’s required minimum lot size. However, as to size, Exhibit 3, see specifically 3B, shows how the proposed construction modestly increases the lot’s building coverage by only 1.4%.

The spirit of the GRA zone dimensional requirement ordinance provisions also contemplate a reasonable width for lot development. This zone requires lots to be 100 feet wide. Subtracting both side yard 10 foot setbacks leaves at least an intended 80 feet of developable land area conforming to the ordinance. Exhibit 4 shows lots long ago created in the GRA zone not sized by this present day standard. Paula’s 50 foot lot less both 10 foot side yard setbacks leaves only 30 feet to work with for reasonable development. The spirit of the ordinance contemplates development on non-conforming lots, but again the specific dimensioning of Paula’s lot doesn’t allow her reasonable proposal to conform to stated dimensional requirements. It is reasonable to grant the requested variances to facilitate Paula’s reasonable site improvements.

The overall spirit of the ordinance encourages development appropriate for the public's health, safety and welfare. Demolition of the existing garage doesn't just promote new code appropriate construction facilitating reasonable use, but facilitates onsite machinery excavation to develop storm water drainage solutions consistent with present best practices. To insist that the existing structure stay put and used as best it can, essentially a storage shed, is inconsistent with the ordinance's spirit promoting safe and appropriate and usable development appropriate not just for present but future owners.

3. Granting the requested setback variance would do substantial justice.

This criteria requires consideration of all the facts relevant to the application, and a balancing of the public's and the Applicant's interests. One way to consider whether "substantial justice" would be done is to determine whether there is any gain to the public that is greater than the loss suffered by the Applicant if the variance is not granted. See, Farrar v City of Keene, 158 N. H. 684, 692 (2009). To apply this legal standard, the ZBA should imagine a scale, and on it weigh the loss suffered to Paula Reid as landowner/applicant on one side, against (on the other side of the scale) the public benefit to be gained by strict adherence to the Zoning Ordinance's dimensional requirements by denying the requested relief

Denying the variances simply because the proposed new construction modestly exceeds dimensional requirements makes no sense. Paula Reid would lose the opportunity to address the stormwater drainage problems that plague the side and back yards. Denial would preclude the opportunity to replace a worn out structure with one of up to date construction and more reasonably sized for use given today's automobile sizes and modest garage storage needs. The value of the improvement will enhance the property's assessment and thus the City's property tax revenue without increasing City service needs, school population, etc. It is hard to articulate any gain to the public, including immediate abutters, in denying the variance.

The proposed development is reasonable. It's in keeping with the neighborhood. As such, the scale tips in favor of Paula Reid.

4. Values of surrounding properties are not diminished by granting these requested setback relief.

ZBA Board members are legally permitted to rely upon their general knowledge and awareness of our area's rapidly appreciating real estate values and competitive real estate market. It is hard to imagine a good faith claim that Paula's reasonable proposal will have an adverse effect on surrounding property values. Property values in Portsmouth's desirable and high demand market continue to escalate. Property values in this general neighborhood will continue to rise after 410 Richards Avenue is improved as proposed.

5. Literal enforcement of the setback requirement from which relief is requested would result in unnecessary hardship because special conditions of the property distinguish it from others in the area, and no fair and substantial relationship exists between the general public purposes of the express setback, lot coverage, and new construction limitations and their specific application to this property.

Special conditions of the subject property do distinguish it from others in the GRA zone. The property's significant drainage problems are addressed above. Literal enforcement of the dimensional requirements and new construction prohibition creates the hardship of being unable to reasonably cure this property's drainage problem special conditions. The purpose of the ordinance sections from which relief is requested is to promote safe and orderly development in the zone. Everything addressed above evidences that literal enforcement (variance application denial) fails that general purpose. Granting the variances instead will allow these special conditions to be addressed to eliminate the drainage hardship the property now endures, and will allow a replacement structure of similar scale, but very modest enlargement, reasonable and appropriate for today's standards of garage use.

Additional special conditions on the site relevant to the application are these. The neighboring lot immediately abutting the existing and proposed garage is at a higher elevation. Both properties have privacy fences screening each site's structures and back yards from the other. See Exhibit 9 pictures. The modest lengthening of a new garage by 5 feet will hardly be seen on account of both fences and their differing heights, especially given the neighbor's fence being taller and at a higher elevation.

Conclusion

All of the above evidence's Paula meeting all of the criteria required to grant the requested variances. Her proposed development will not threaten the public health, safety and welfare which is the general purpose of Portsmouth's Zoning Ordinance. The request variances are reasonable and should be granted.

Sincerely



Christopher A. Wyskiel

CAW/lew
Enclosures
cc: Paula J. Reid

City of Portsmouth
Zoning Board of Adjustment
1 Junkins Avenue, 3rd Floor
Portsmouth, NH 03801

LETTER OF AUTHORIZATION

Re: Variance – 410 Richards Avenue, Portsmouth, NH
Owners: Paula J. Reid, Trustee of the Paula J. Reid 2003 Revocable Trust

Dear Sir/Madam:

Paula J. Reid, individually and as Trustee of the Paula J. Reid 2003 Revocable Trust, authorize my attorney, Christopher A. Wyskiel of Wyskiel, Boc, Tillinghast & Bolduc, P.A. to represent me, individually and in my landowning trustee capacity, before the Zoning Board of Adjustment regarding variance requests for the above referenced property.

Sincerely,

Dated: November 27, 2023

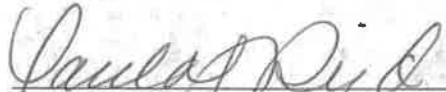
Paula J. Reid, Individually and as Trustee
of the Paula J. Reid 2003 Revocable Trust

H:RE & BUSREID - PAULA - Portsmouth Variance\Authorization.docx

Exh. 1

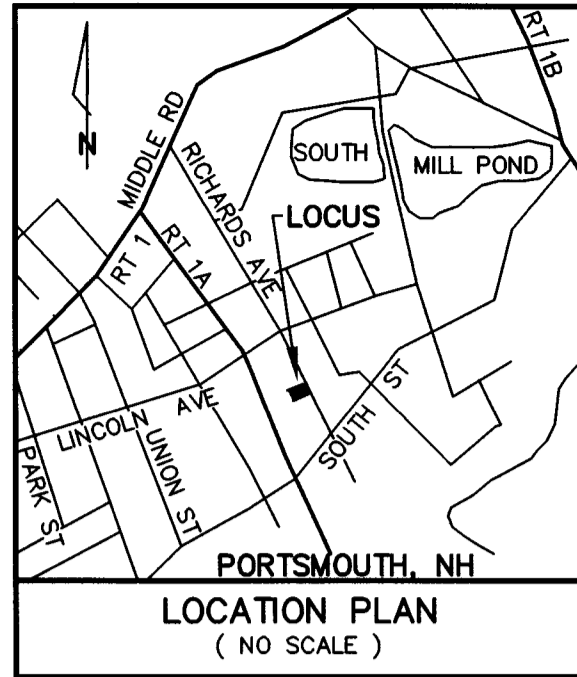

REFERENCE PLANS:

- 1.) PLAN SHOWING PROPERTY OF EMERY, BOYNTON AND GRIFFIN, PORTSMOUTH, N.H. SECTIONS 1 AND 2, SCALE: 1" = 20'; DATED: OCTOBER 1898; BY: L.E. SCRUTON. RECORDED R.C.R.D. PLAN 00123 1 & 2 OF 2.
- 2.) STANDARD PROPERTY SURVEY FOR PROPERTY AT 420 RICHARDS AVENUE, PORTSMOUTH, ROCKINGHAM COUNTY, NEW HAMPSHIRE, OWNED BY AMY DUTTON AND BROOKS MURPHY, 41 ELDRIDGE ROAD, YORK, MAINE. SCALE: 1" = 10'; DATED: AUGUST 18, 2010, REVISED THROUGH 8/30/10; BY: EASTERLY SURVEYING, INC. RECORDED R.C.R.D. PLAN D-36530.
- 3.) BOUNDARY SURVEY FOR JAMES A. MULLEN & KRISTEN B. MULLEN, 295 MILLER AVE., TAX MAP 130, LOT 9, PORTSMOUTH, NH. SCALE: 1" = 10'; DATED: AUGUST 19, 2013; BY: ROSS ENGINEERING. RECORDED R.C.R.D. PLAN D-37887.
- 4.) STANDARD PROPERTY SURVEY - TAX MAP 112, LOT 6, PROPERTY OF THE MCAULIFFE FAMILY REVOCABLE TRUST OF 2011, 452 & 460 RICHARDS AVENUE, PORTSMOUTH, NEW HAMPSHIRE, COUNTY OF ROCKINGHAM. SCALE: 1" = 20'; DATED: SEPTEMBER 14, 2012, REVISED THROUGH 1/16/13; BY: MSC CIVIL ENGINEERS & LAND SURVEYORS, INC. RECORDED R.C.R.D. PLAN D-37568.

NOTES:

- 1.) OWNER OF RECORD:
PAULA J. REID 2003 REVOCABLE TRUST
PAULA J. REID, TRUSTEE
410 RICHARDS AVENUE
PORTSMOUTH, NEW HAMPSHIRE 03801
R.C.R.D. VOLUME 5998, PAGE 2091.
- 2.) 112 / 10 - DENOTES TAX MAP AND PARCEL NUMBER.
- 3.) PARCEL AREA = 6,149 S.F. / 0.14 Ac.
- 4.) THE INTENT OF THIS PLAN IS TO DEPICT THE PARCELS BOUNDARIES AND EXISTING SITE CONDITIONS AS OF OCTOBER 18, 2022.
- 5.) ZONING DISTRICT IS GENERAL RESIDENCE A (GRA).

MINIMUM LOT DIMENSIONS:
LOT AREA = 7,500 S.F.
CONTINUOUS STREET FRONTAGE = 100 FEET
DEPTH = 70 FEET

MINIMUM YARD DIMENSIONS:
FRONT = 15 FEET
SIDE = 10 FEET
REAR = 20 FEET

MAXIMUM STRUCTURE DIMENSIONS:
SLOPED ROOF = 35 FEET
ROOF APPURTENANCE HEIGHT = 8 FEET
BUILDING COVERAGE = 25 PERCENT

MINIMUM OPEN SPACE = 30 PERCENT
- 6.) THE SUBJECT PARCEL IS OUTSIDE OF THE 0.2 PERCENT ANNUAL CHANGE FLOODPLAIN AS SHOWN ON FLOOD INSURANCE RATE MAP COMMUNITY NUMBER 330139; PANEL 0259; SUFFIX F; MAP NUMBER 33015C0259F; EFFECTIVE DATE JANUARY 29, 2021.
- 7.) BASIS OF BEARING IS NH STATE PLANE (NAD83) BASED ON GPS OBSERVATION DATED OCTOBER 12, 2022.
VERTICAL DATUM IS NAVD88 BASED ON GPS OBSERVATION DATED OCTOBER 12, 2022.
- 8.) THIS PLAN SHOWS ONLY THOSE FEATURES THAT WERE VISUALLY APPARENT ON THE DATE OF THE SURVEY. THE ABSENCE OF SUBSURFACE STRUCTURES, UTILITIES, ETC. FROM THIS PLAN, BUT IN EXISTENCE, IS NOT INTENDED OR IMPLIED.

130 / 9
KRISTEN B. MULLEN
REVOCABLE LIVING TRUST
295 MILLER AVE
PORTSMOUTH, NH 03801
5699 / 1271
REFERENCE PLAN #2

112 / 11
TWOMBLY TRUST
303 MILLER AVE
PORTSMOUTH, NH 03801
2762 / 2766

112 / 11
STEBBINS FAMILY TRUST
390 RICHARDS AVE
PORTSMOUTH, NH 03801
5636 / 563

112 / 18
BARBARA A. COLLIER
REVOCABLE TRUST
399 RICHARDS AVE
PORTSMOUTH, NH 03801
6315 / 246

112 / 19
STEPHEN C. BUZZELL
REVOCABLE TRUST
409 RICHARDS AVE
PORTSMOUTH, NH 03801
6035 / 840

112 / 20
THOMAS A. NIES
REVOCABLE TRUST OF 2010
419 RICHARDS AVE
PORTSMOUTH, NH 03801
5192 / 1225

112 / 9
AMY E. DUTTON REVOCABLE
LIVING TRUST
420 RICHARDS AVE
PORTSMOUTH, NH 03801
5225 / 39
REFERENCE PLAN #1

LEGEND

- S.F. - SQUARE FEET
- Ac. - ACRE
- (TYP.) - TYPICAL
- ± - MORE OR LESS
- Ø - DIAMETER
- R.C.R.D. - ROCKINGHAM COUNTY REGISTRY OF DEEDS
- WS - WATER SHUT-OFF (CURB STOP)
- WV - WATER GATE VALVE
- ⊗ - FIRE HYDRANT
- I.P.(fnd) - IRON PIPE (FOUND)
- I.R.(fnd) - IRON ROD (FOUND)
- I.R.(tbs) - IRON ROD (TO BE SET)
- UP - UTILITY POLE
- A/C - AIR CONDITIONING UNIT
- OHU - OVERHEAD UTILITY LINES

NO.	DATE	DESCRIPTION	BY	CHK
REVISIONS				
22-2467		BOUNDARY	22-10	62
PROJECT NO		TYPE	FIELDBOOK & PAGES	

"I HEREBY CERTIFY THAT THIS PLAN IS BASED ON AN ACTUAL GROUND SURVEY PERFORMED WITH A TOTAL STATION, BY ME OR THOSE UNDER MY DIRECT SUPERVISION AND THAT, TO THE BEST OF MY KNOWLEDGE AND BELIEF, SAID SURVEY MEETS OR EXCEEDS THE MINIMUM PRECISION REQUIREMENTS FOR SURVEY CLASSIFICATION "U" AS SET FORTH IN TABLE 500.1 OF THE NEW HAMPSHIRE CODE OF ADMINISTRATIVE RULES OF THE BOARD OF LICENSURE FOR LAND SURVEYORS."

"I CERTIFY THAT THIS SURVEY PLAT IS NOT A SUBDIVISION PURSUANT TO THIS TITLE AND THAT THE LINES OF STREETS AND WAYS SHOWN ARE THOSE OF PUBLIC OR PRIVATE STREETS OR WAYS ALREADY ESTABLISHED AND THAT NO NEW WAYS ARE SHOWN." (RSA 676:18)
10/25/22
DATE: / KEVIN M. McENEANEY LLS # 661

BOUNDARY SURVEY PLAN
PREPARED FOR
PAULA J. REID 2003 REVOCABLE TRUST
TAX MAP 112, LOT No. 10
410 RICHARDS AVE
CITY of PORTSMOUTH
COUNTY of ROCKINGHAM
STATE of NEW HAMPSHIRE

DRAWN BY: KJP FILE: 2467\DWGS\22-2467
SCALE: 1" = 10' DATE: OCTOBER 25, 2022

McEneaney Survey Associates
of NEW ENGLAND
P.O. Box 681 - 24 CHESTNUT STREET
DOVER, NH 03820 (603) 742-0911
SURVEYING - PLANNING - CONSULTING

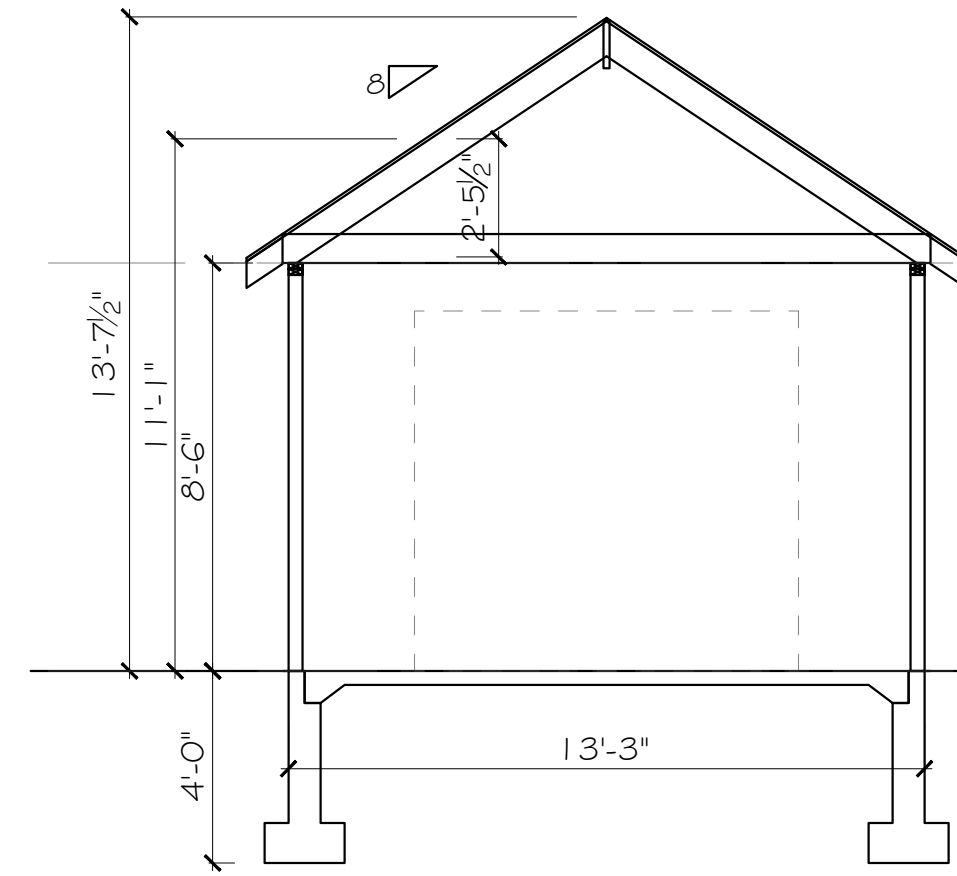

A SECTION A
 Scale: 1/4" = 1'-0"

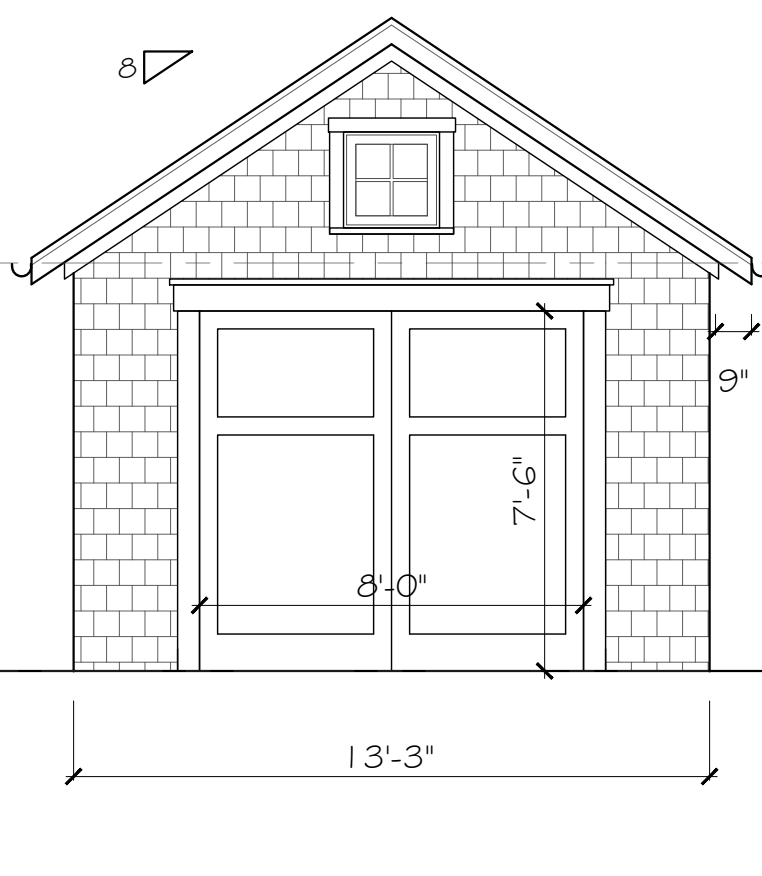

1 FRONT ELEVATION
 Scale: 1/4" = 1'-0"

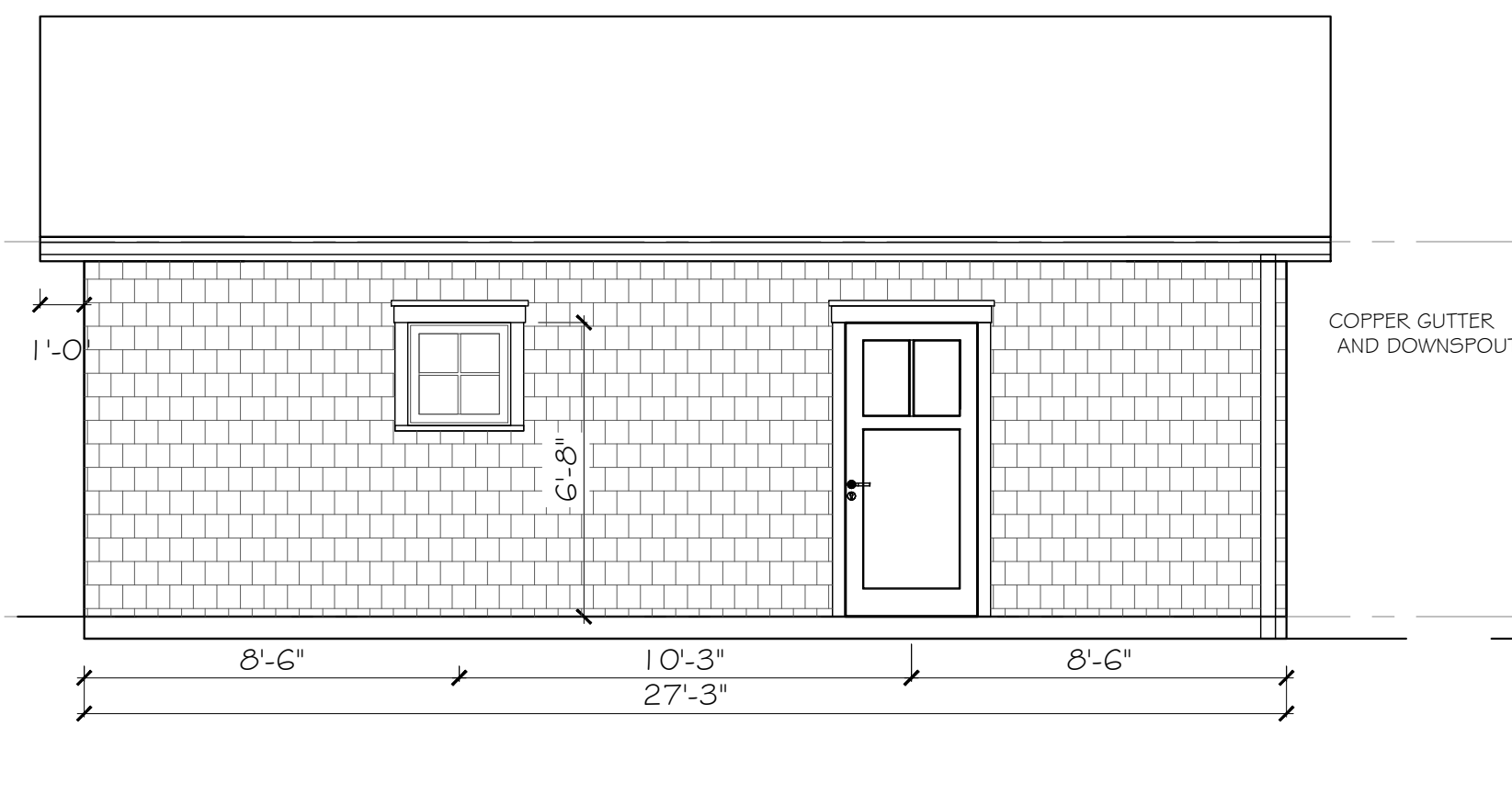

2 RIGHT ELEVATION
 Scale: 1/4" = 1'-0"

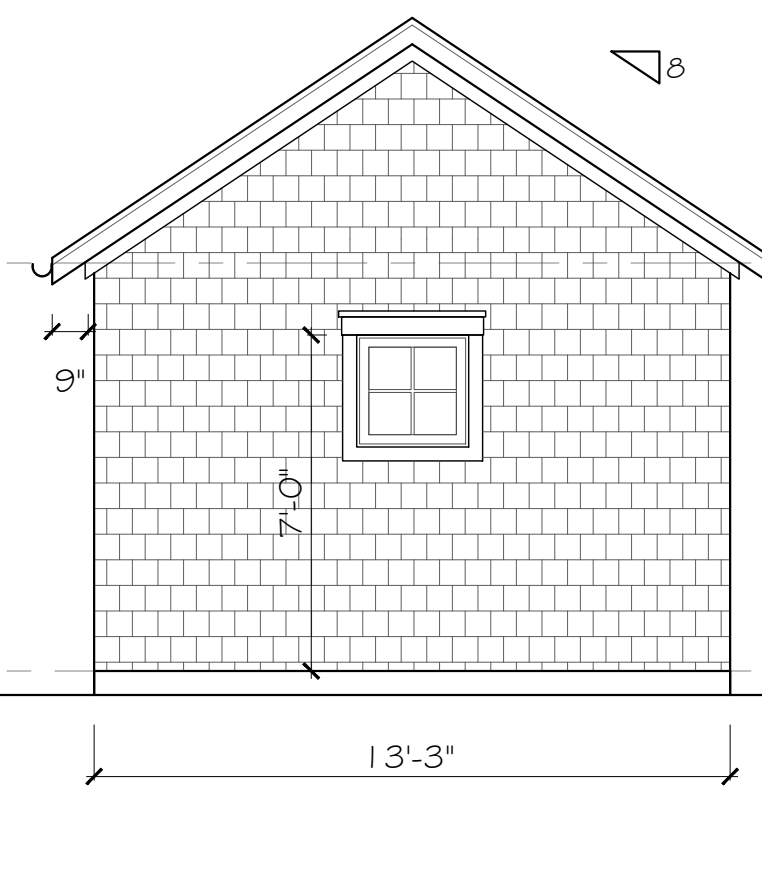

3 REAR ELEVATION
 Scale: 1/4" = 1'-0"

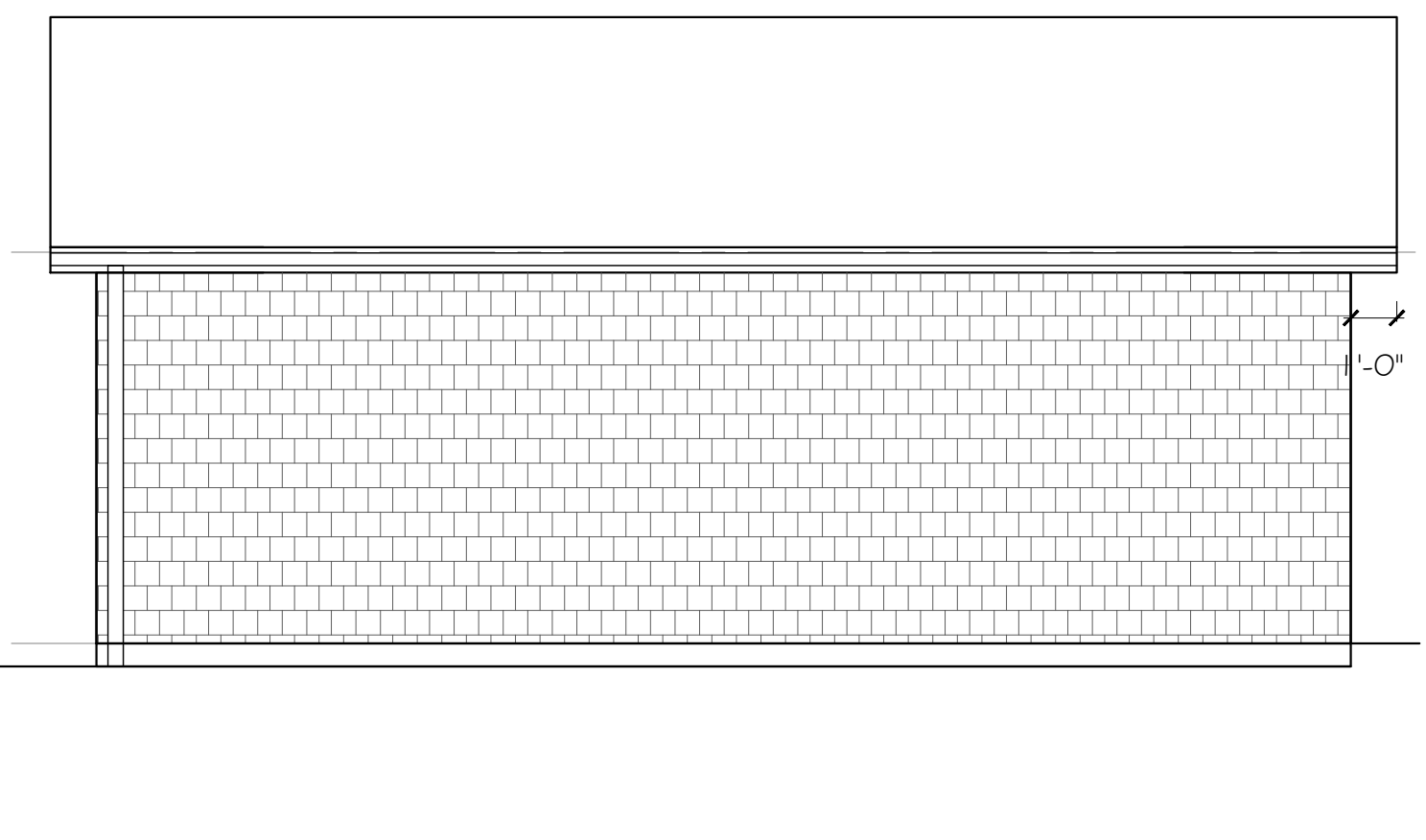

4 LEFT ELEVATION
 Scale: 1/4" = 1'-0"

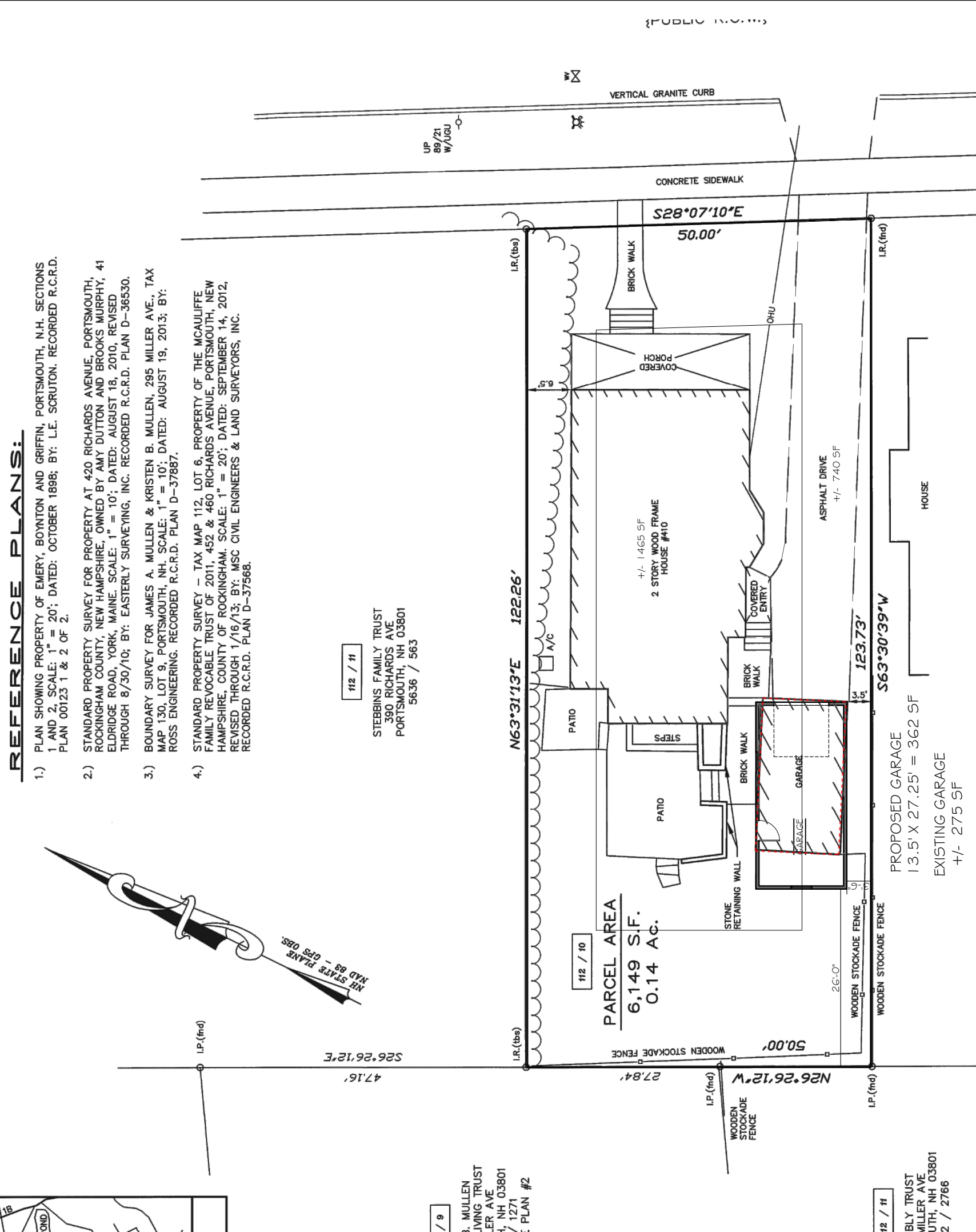

NOTES:

- OWNER OF RECORD: PAULA J. REID 2003 REVOCABLE TRUST, PAULA J. REID, TRUSTEE, 410 RICHARDS AVENUE, PORTSMOUTH, NEW HAMPSHIRE 03801, R.C.R.D. VOLUME 599B, PAGE 2091.
- FILE / NO - DENOTES TAX MAP AND PARCEL NUMBER.
- PARCEL AREA = 6,149 S.F. / 0.14 AC.
- THE INTENT OF THIS PLAN IS TO DEPICT THE PARCELS BOUNDARIES AND EXISTING SITE CONDITIONS AS OF OCTOBER 18, 2022.
- ZONING DISTRICT IS GENERAL RESIDENCE A (GRA).

	EXISTING	PROPOSED
MINIMUM LOT DIMENSIONS:		
LOT AREA	= 7,500 S.F.	6,149 S.F.
CONTINUOUS STREET FRONTAGE	= 100 FEET	50 FT.
DEPTH	= 70 FEET	123 FT.
MINIMUM YARD DIMENSIONS:		
FRONT	= 15 FEET	15 FT.
REAR	= 20 FEET	20 FT.
MAXIMUM STRUCTURE DIMENSIONS:		
SLOPED ROOF	= 25 FEET	25 FT.
ROOF APPURTENANCE HEIGHT	= 8 FEET	8 FT.
BUILDING COVERAGE	1465 + 275 = 1740 SF	1465 + 362 = 1827 SF
	1740 / 6149 = 28.3%	1827 / 6149 = 29.7%
MINIMUM OPEN SPACE		
	= 30 PERCENT	50.7%
		50.3%

6. THE SUBJECT PARCEL IS OUTSIDE OF THE 0.2 PERCENT ANNUAL CHANCE FLOOD PLAN AS SHOWN ON FLOOD INSURANCE RATE MAP COMMUNITY NUMBER 330139; PANEL 0259; SUPER F. MAP NUMBER 3301500259F; EFFECTIVE DATE, JANUARY 29, 2021.

7. BASIS OF BEARING IS NH STATE PLANE (NAD83) BASED ON GPS OBSERVATION DATED OCTOBER 12, 2022. VERTICAL DATUM IS NAVD88 BASED ON GPS OBSERVATION DATED OCTOBER 12, 2022.

8. THIS PLAN SHOWS ONLY THOSE FEATURES THAT WERE VISUALLY APPARENT ON THE DATE OF THE SURVEY. THE ABSENCE OF SUBSURFACE STRUCTURES, UTILITIES, ETC. FROM THIS PLAN, BUT IN EXISTENCE, IS NOT INTENDED OR IMPLIED.

BUILDING COVERAGE
 EXISTING: 1465 + 275 = 1740 SF
 1740 / 6149 = 28.3%
 PROPOSED: 1465 + 362 = 1827 SF
 1827 / 6149 = 29.7%

OPEN SPACE
 EXISTING: 1740 (BUILDINGS) + 740 (DRIVEWAY) = 2480 SF
 6149 - 2480 = 3669 (OPEN) -> 3669 / 6149 = 59.7%
 PROPOSED: 1827 + 740 = 2567 SF
 6149 - 2567 = 3582 (OPEN) -> 3582 / 6149 = 58.3%

CALCULATIONS BASED ON EXISTING CONDITION SURVEY PROVIDED BY:

BOUNDARY SURVEY PLAN
 PREPARED FOR
 PAULA J. REID 2003 REVOCABLE TRUST
 TAX MAP 112, LOT No. 10
 410 RICHARDS AVE.
 CITY OF PORTSMOUTH
 COUNTY OF ROCKINGHAM
 STATE OF NEW HAMPSHIRE

DRAWN BY: [Signature] FILE: 2467200352-2467
 SCALE: 1" = 10' DATE: OCTOBER 28, 2022

Meganey Survey Associates
 of NEW ENGLAND
 P.O. Box 681 - 24 CHESTNUT STREET
 DOVER, NH 03820 (603) 742-0911
 SURVEYING - PLANNING - CONSULTING

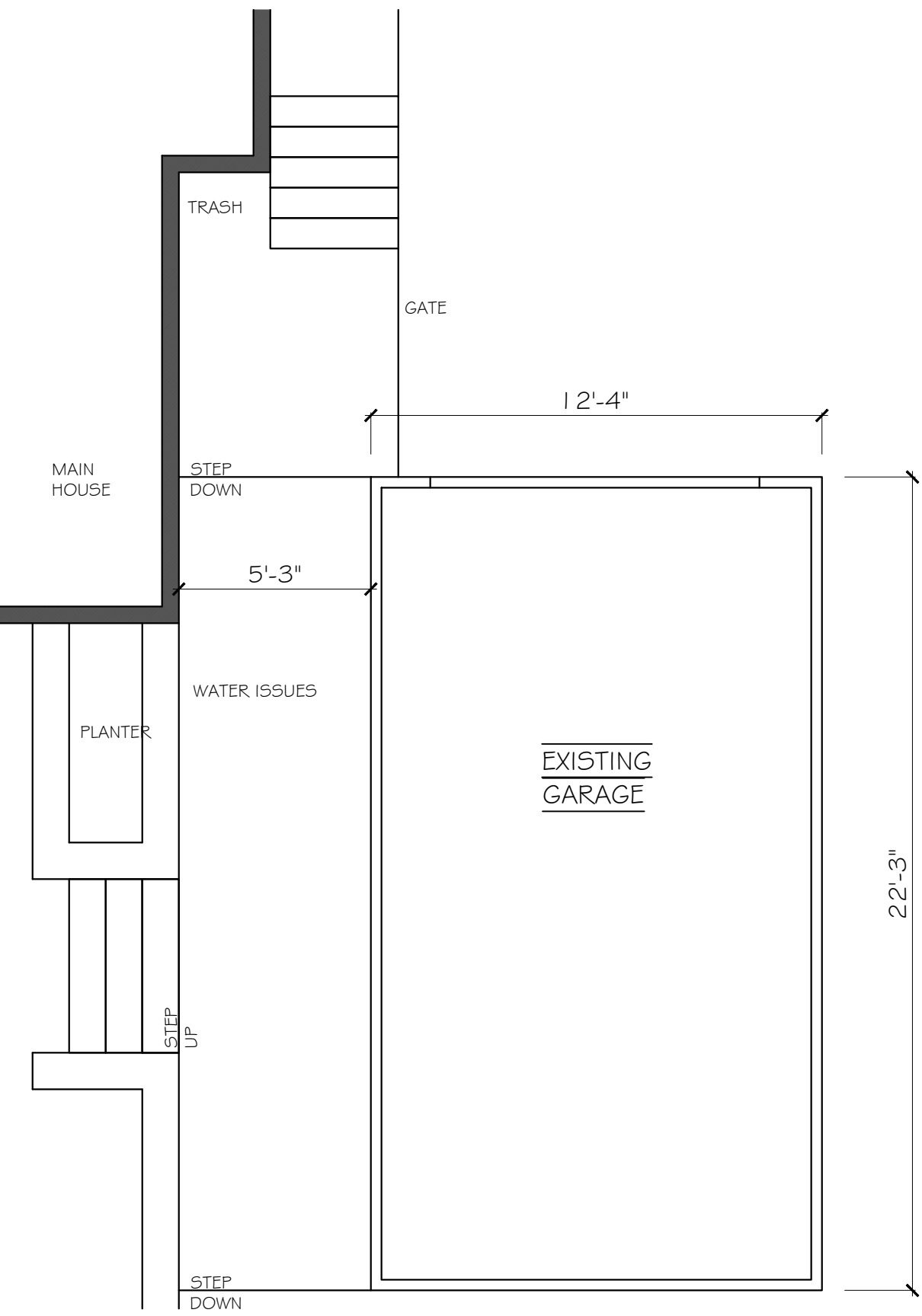

0 EXISTING
 Scale: 1/4" = 1'-0"

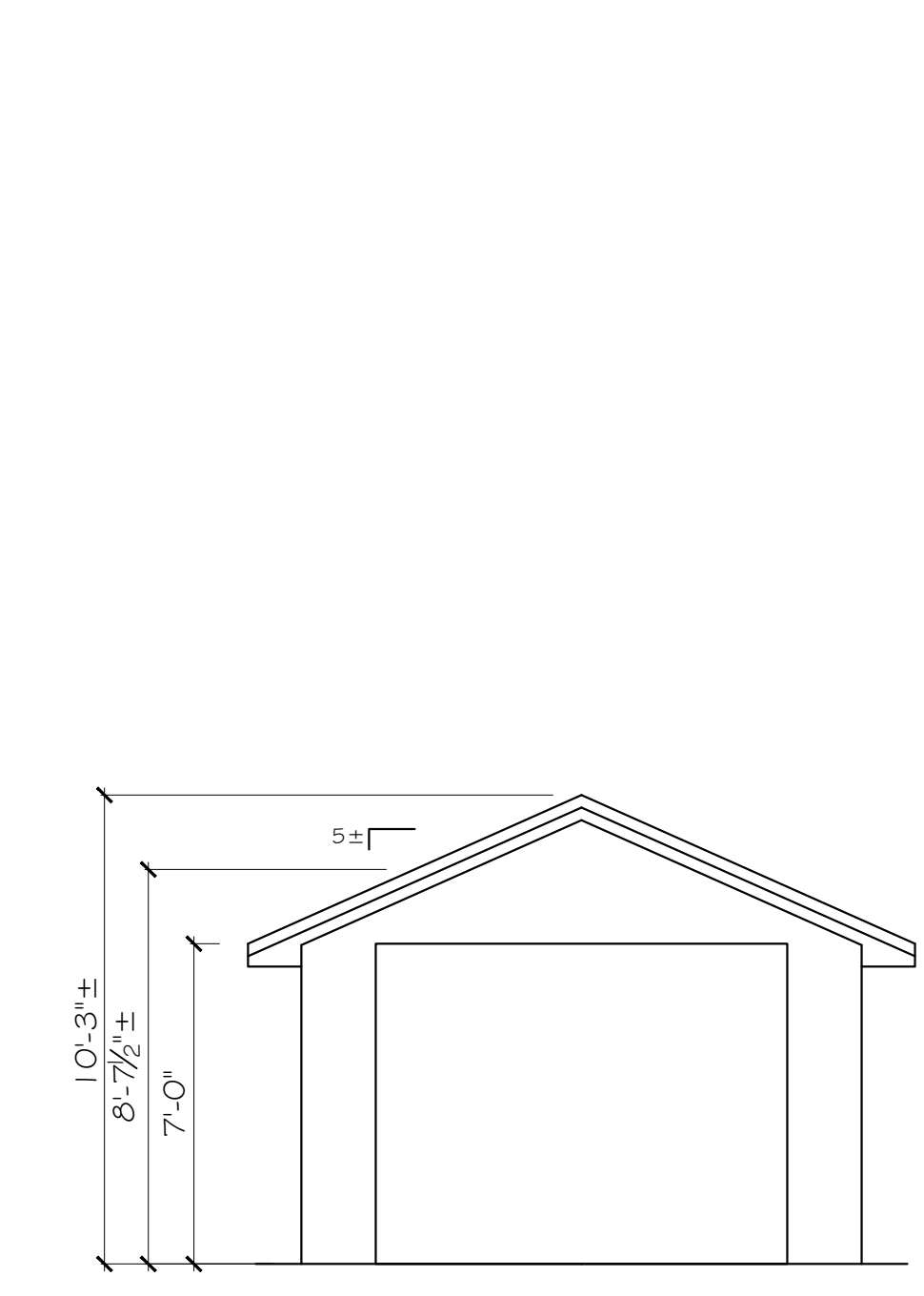

EXISTING BUILDING FOOTPRINT- 275 SF

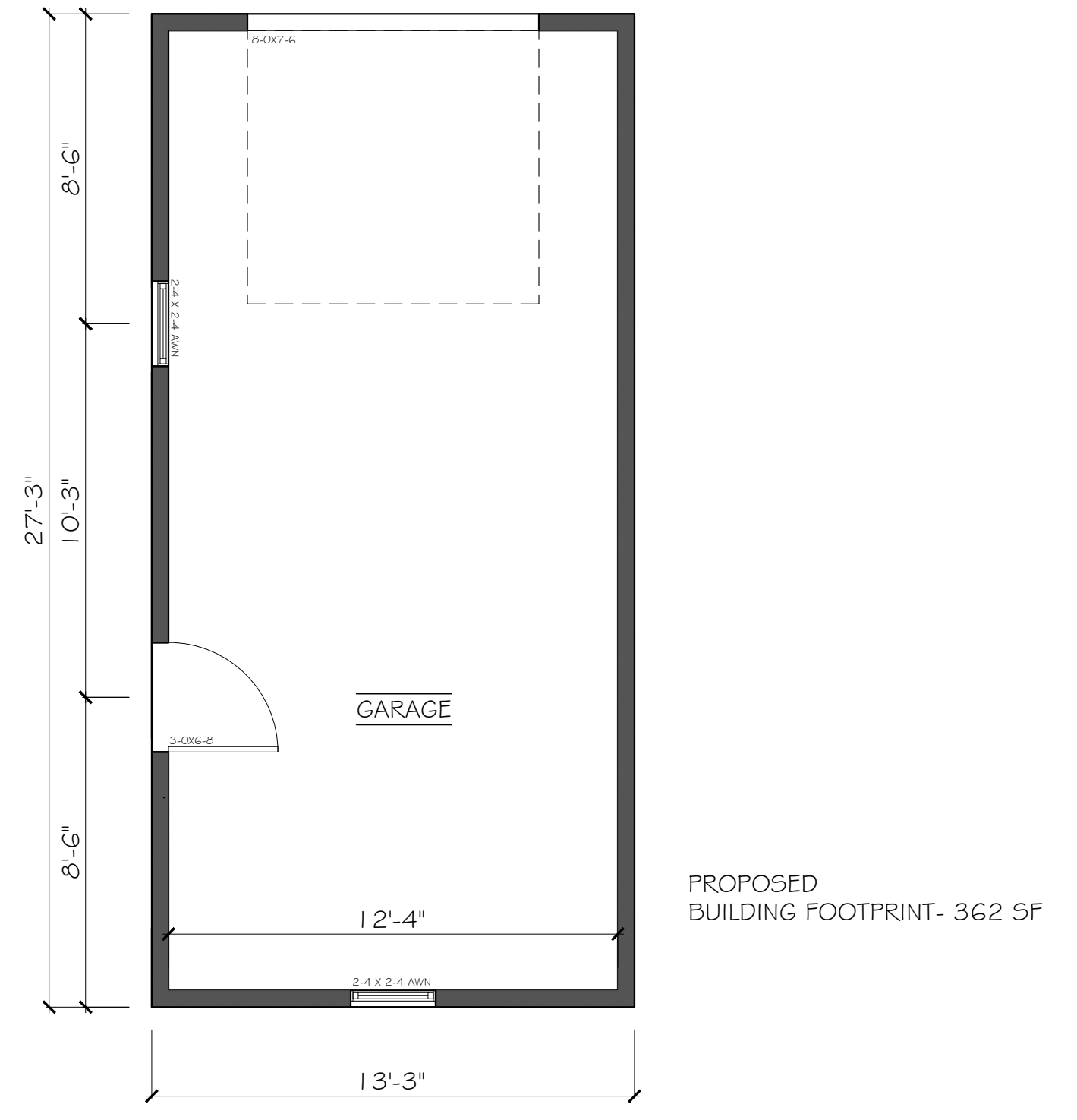

1 FIRST FLOOR PROPOSED PLAN
 Scale: 1/4" = 1'-0"

FLOOR PLANS

SCALE: 1/4" = 1'-0"
 DATE: 28 NOVEMBER 2023
 REVISIONS:

PROPOSED GARAGE FOR:
THE REID RESIDENCE
 410 RICHARDS AVENUE
 PORTSMOUTH - NH 03801



112 / 11

STEBBINS FAMILY TRUST
390 RICHARDS AVE
PORTSMOUTH, NH 03801
5636 / 563

9

B. MULLEN
LIVING TRUST
LER AVE
H, NH 03801
/ 1271
E PLAN #2

47.16'
S26°26'12"E

I.R.(tbs)

N63°31'13"E 122.26'

I.R.(tbs)

112 / 10

PARCEL AREA
6,149 S.F.
0.14 Ac.

+/- 1465 SF
2 STORY WOOD FRAME
HOUSE #410

I.P.(md)
WOODEN STOCKADE FENCE

27.84'
WOODEN STOCKADE FENCE

N26°26'12"W
50.00'

I.P.(md)

WOODEN STOCKADE FENCE

WOODEN STOCKADE FENCE

26'-0"

123.73'

I.R.(md)

S63°30'39"W

PROPOSED GARAGE
13.5' X 27.25' = 362 SF

EXISTING GARAGE
+/- 275 SF

ASPHALT DRIVE
+/- 740 SF

HOUSE

S28°07'10"E
50.00'

CONCRETE SIDEWALK

VERTICAL GRANITE CURB

FRONT YARD

12 / 11

BLY TRUST
MILLER AVE
OUTH, NH 03801
2 / 2766



DRAWN BY
SCALE:
10

PAUL

CALCUL
PROPOE
6149 -

OPEN SI
EXISTINC
6149 -

PROPOE
1827 / 4

BUILDIN
EXISTINC
1740 / 4

THIS PL
APP ARE
SUBSUR
BUT IN

BASIS O
OBSERV/
VERTICAL
OCTOBER

6.) THE SUE
CHANCE
COMMUN
33015CO

MINIMUM
EX

MAXIMUM
SIC
RO
BUI

MINIMUM
FRC
SIDI
REL

MINIMUM
LOT
CO
DEF

5.) ZONING
THE INTE
AND EXI

2.) 112 /
PARCEL

1.) OWNER

Exh. 3A

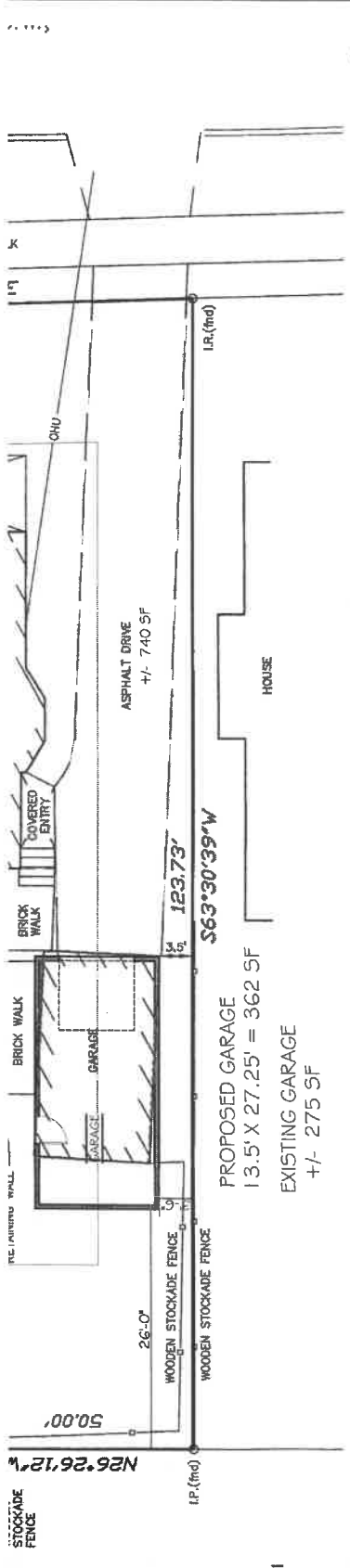

NOTES:

- 1.) OWNER OF RECORD:
PAULA J. REID 2003 REVOCABLE TRUST
PAULA J. REID, TRUSTEE
410 RICHARDS AVENUE
PORTSMOUTH, NEW HAMPSHIRE 03801
R.C.R.D. VOLUME 5998, PAGE 2091.
- 2.) 112 / 10 - DENOTES TAX MAP AND PARCEL NUMBER.
- 3.) PARCEL AREA = 6,149 S.F. / 0.14 Ac.
- 4.) THE INTENT OF THIS PLAN IS TO DEPICT THE PARCELS BOUNDARIES AND EXISTING SITE CONDITIONS AS OF OCTOBER 18, 2022.
- 5.) ZONING DISTRICT IS GENERAL RESIDENCE A (GRA).

	APPROX. CALCULATIONS	
	EXISTING	PROPOSED
MINIMUM LOT DIMENSIONS:		
LOT AREA	= 7,500 S.F.	6149 SF
CONTINUOUS STREET FRONTAGE	= 100 FEET	50 FT
DEPTH	= 70 FEET	123 FT
MINIMUM YARD DIMENSIONS:		
FRONT	= 15 FEET	15 FT
SIDE	= 10 FEET	3.5 FT
REAR	= 20 FEET	31 FT
MAXIMUM STRUCTURE DIMENSIONS:		
SLOPED ROOF	= 35 FEET	8'-7.5"
ROOF APPURTENANCE HEIGHT	= 8 FEET	11'-1"
BUILDING COVERAGE	= 25 PERCENT	28.3%
MINIMUM OPEN SPACE	= 30 PERCENT	59.7%

- 6.) THE SUBJECT PARCEL IS OUTSIDE OF THE 0.2 PERCENT ANNUAL CHANGE FLOODPLAIN AS SHOWN ON FLOOD INSURANCE RATE MAP COMMUNITY NUMBER 330139; PANEL 0259; SUFFIX F; MAP NUMBER 33015C0259F; EFFECTIVE DATE JANUARY 29, 2021.
- 7.) BASIS OF BEARING IS NH STATE PLANE (NAD83) BASED ON GPS OBSERVATION DATED OCTOBER 12, 2022. VERTICAL DATUM IS NAVD88 BASED ON GPS OBSERVATION DATED OCTOBER 12, 2022.
- 8.) THIS PLAN SHOWS ONLY THOSE FEATURES THAT WERE VISUALLY APPARENT ON THE DATE OF THE SURVEY. THE ABSENCE OF SUBSURFACE STRUCTURES, UTILITIES, ETC. FROM THIS PLAN, BUT IN EXISTENCE, IS NOT INTENDED OR IMPLIED.

BUILDING COVERAGE
 EXISTING: 1465 + 275 = +/- 1740 SF
 1740 / 6149 = 28.3%

PROPOSED 1465 + 362 = 1827 SF
 1827 / 6149 = 29.7%

OPEN SPACE
 EXISTING 1740 (BUILDINGS) + 740 (DRIVEWAY) = 2480 SF
 6149 - 2480 - 3669 (OPEN) -> 3669 / 6149 = 59.7%

PROPOSED 1827 + 740 = 2567 SF
 6149 - 2567 = 3582 (OPEN) -> 3582 / 6149 = 58.3%

CALCULATIONS BASED ON EXISTING CONDITION SURVEY PROVIDED BY:

BOUNDARY SURVEY PLAN
 PREPARED FOR
PAULA J. REID 2003 REVOCABLE TRUST
 TAX MAP 112, LOT No. 10
 410 RICHARDS AVE
 CITY of PORTSMOUTH
 COUNTY of ROCKINGHAM
 STATE of NEW HAMPSHIRE

DRAWN BY: **KJF** FILE: 2467\DWGS\22-2467
 SCALE: 1" = 10' DATE: OCTOBER 25, 2022

M. McEneaney Survey Associates
 LICENSED SURVEYOR
 No. 681
 KEVIN M. McENEANEY

Exh 3B

Microfilm Plan # 125

(Sheet 2 of 2)

dated October 1898

(previously 539/481)

00125

2 of 2

AVENUE

AVENUE
LINCOLN

No 5

No 6

No 7

No 8

No 9

No 10

No 11

No 12

A.L. Flays

PLAN SHOWING PROPERTY
or

EMERY HOYN'TON GRIFFIN
PORTSMOUTH N. H.

Surveyed October 1898. Scale 50 Feet to the Inch
L.F. ROBERTSON
Map 112
Lot 10

No 17

No 18

No 19

No 20

No 21

No 22

No 23

No 24

City of Portsmouth

410
Richards
Ave.

8

AVENUE

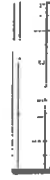

Section 2

Exh. 4 (p. 1 of 2)

Microfilm Plan # 125

(Sheet 1 of 2)

Dated October 1898

(Previously 539/481)

00125 1 of 2

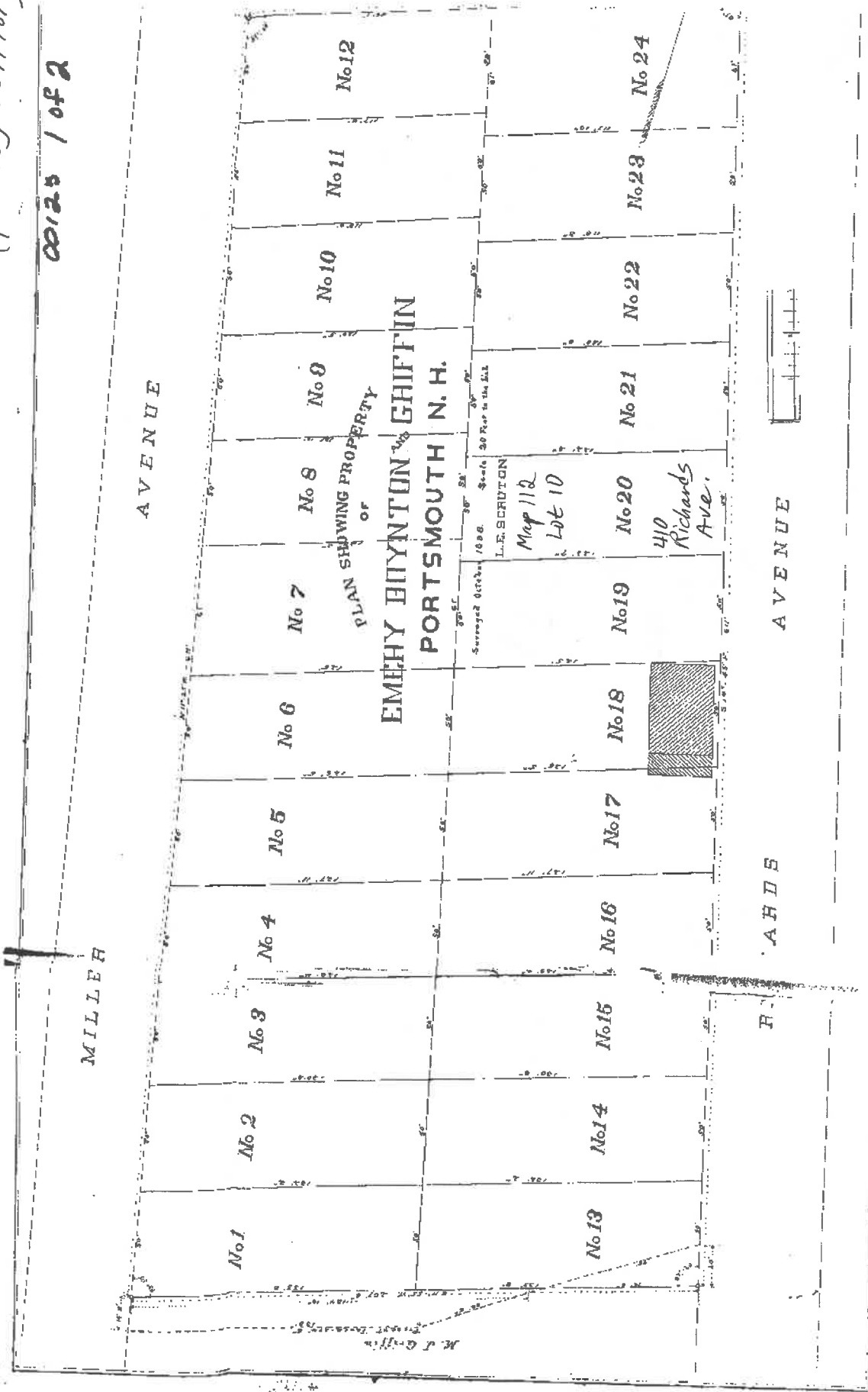

Section 1

Exh. 4 (p. 2 of 2)

410 Richards Avenue



MAP FOR REFERENCE ONLY
NOT A LEGAL DOCUMENT

City of Portsmouth, NH makes no claims and no warranties, expressed or implied, concerning the validity or accuracy of the GIS data presented on this map.

Geometry updated 06/24/2023
Data updated 3/9/2022

Print map scale is approximate.
Critical layout or measurement activities should not be done using this resource.

Exh. 5A



410 Richards Ave

Exh. 6

Exh. 6



Exh. 6

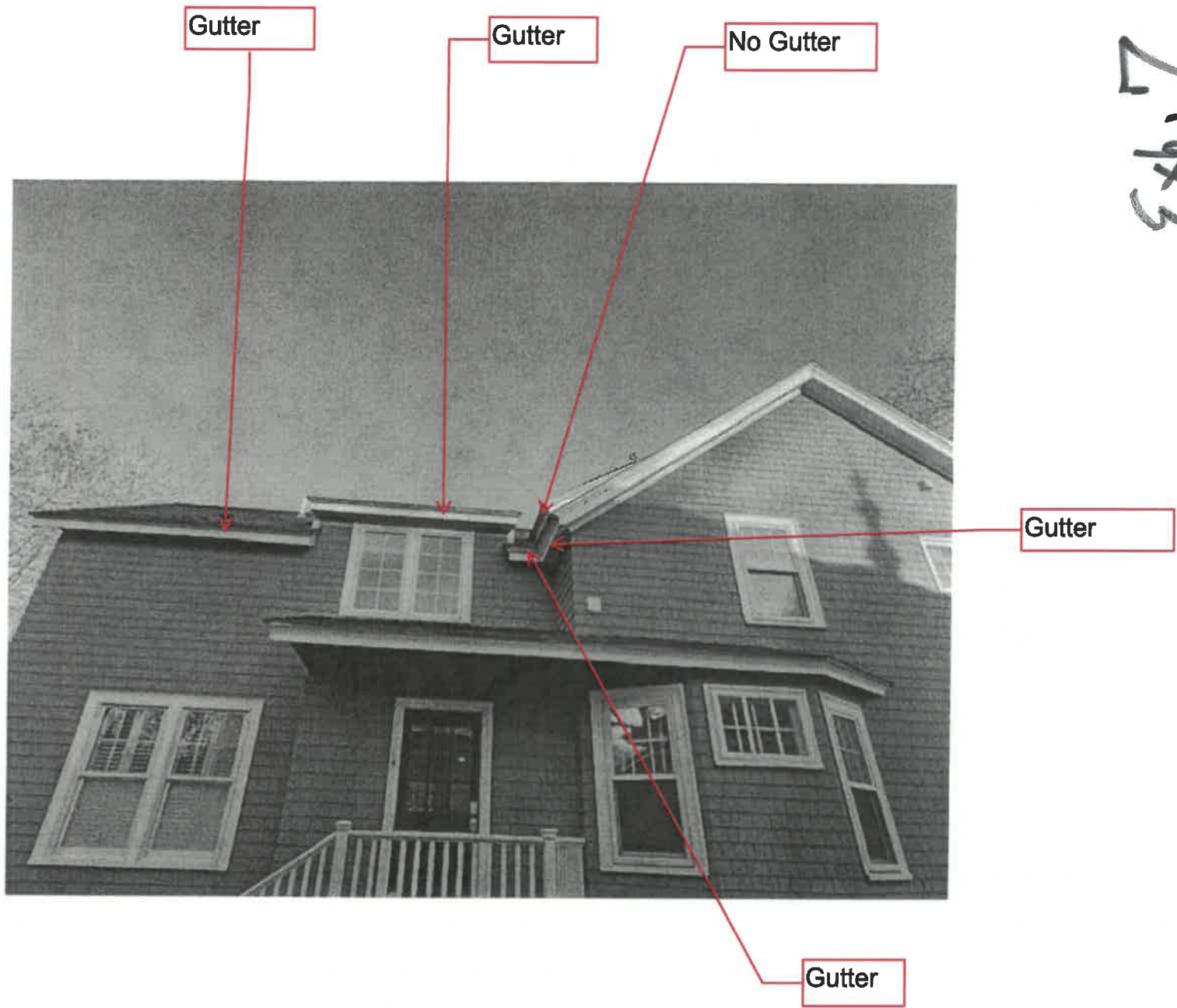

Ex. 7
L. 43

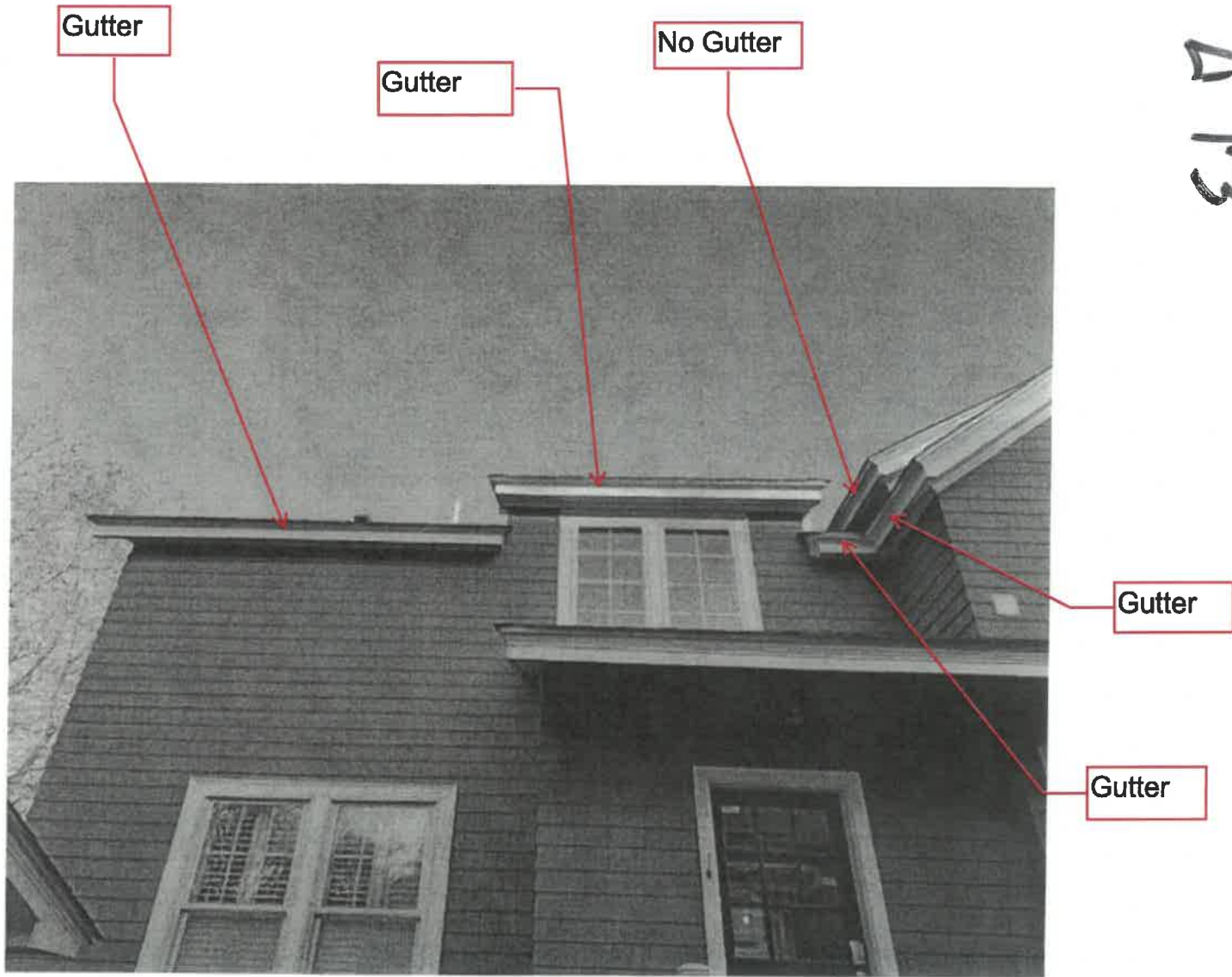

Ex. 17

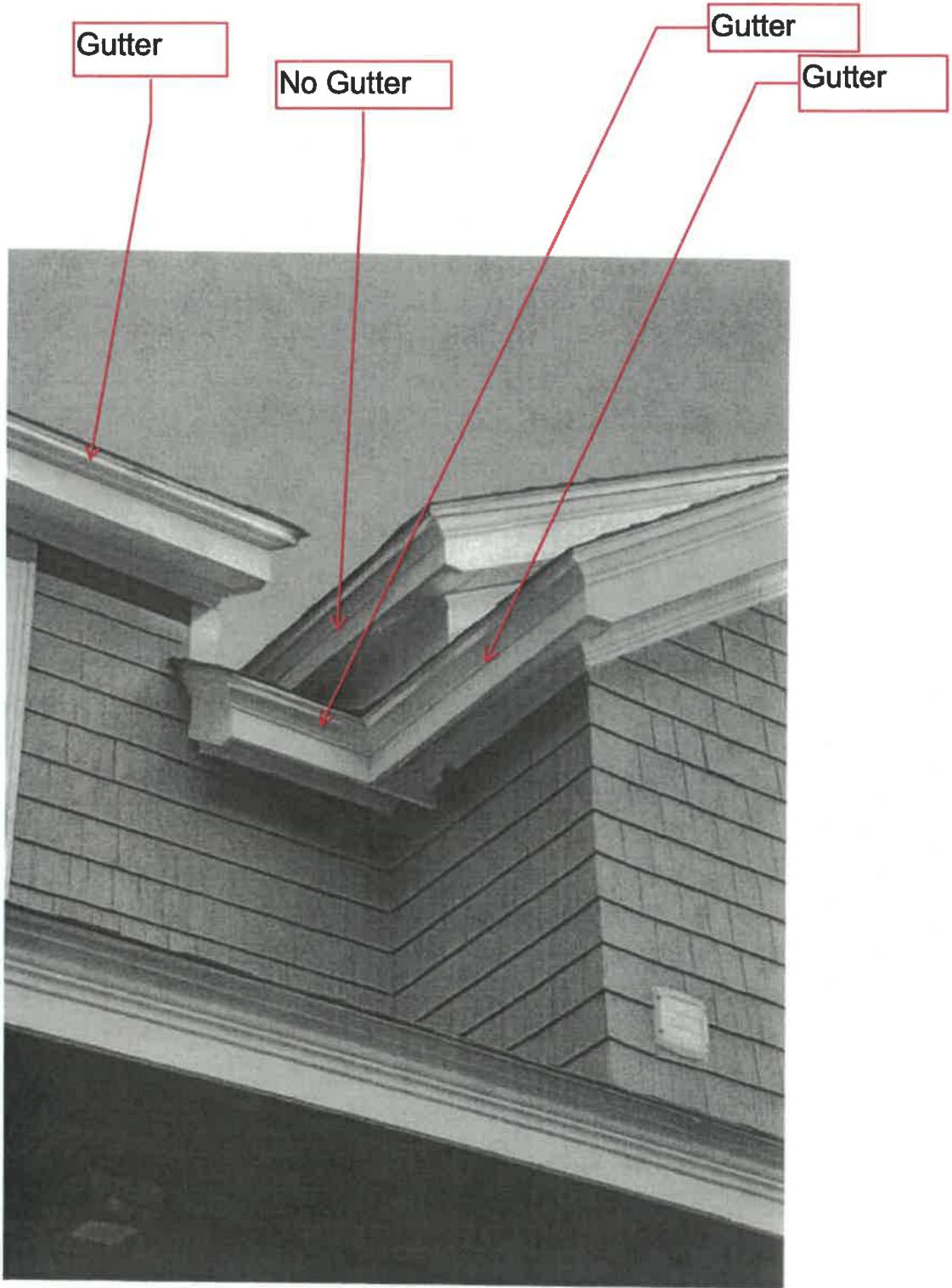

Exh. 7



Exh. 8



Exh. 8



Exh. 8

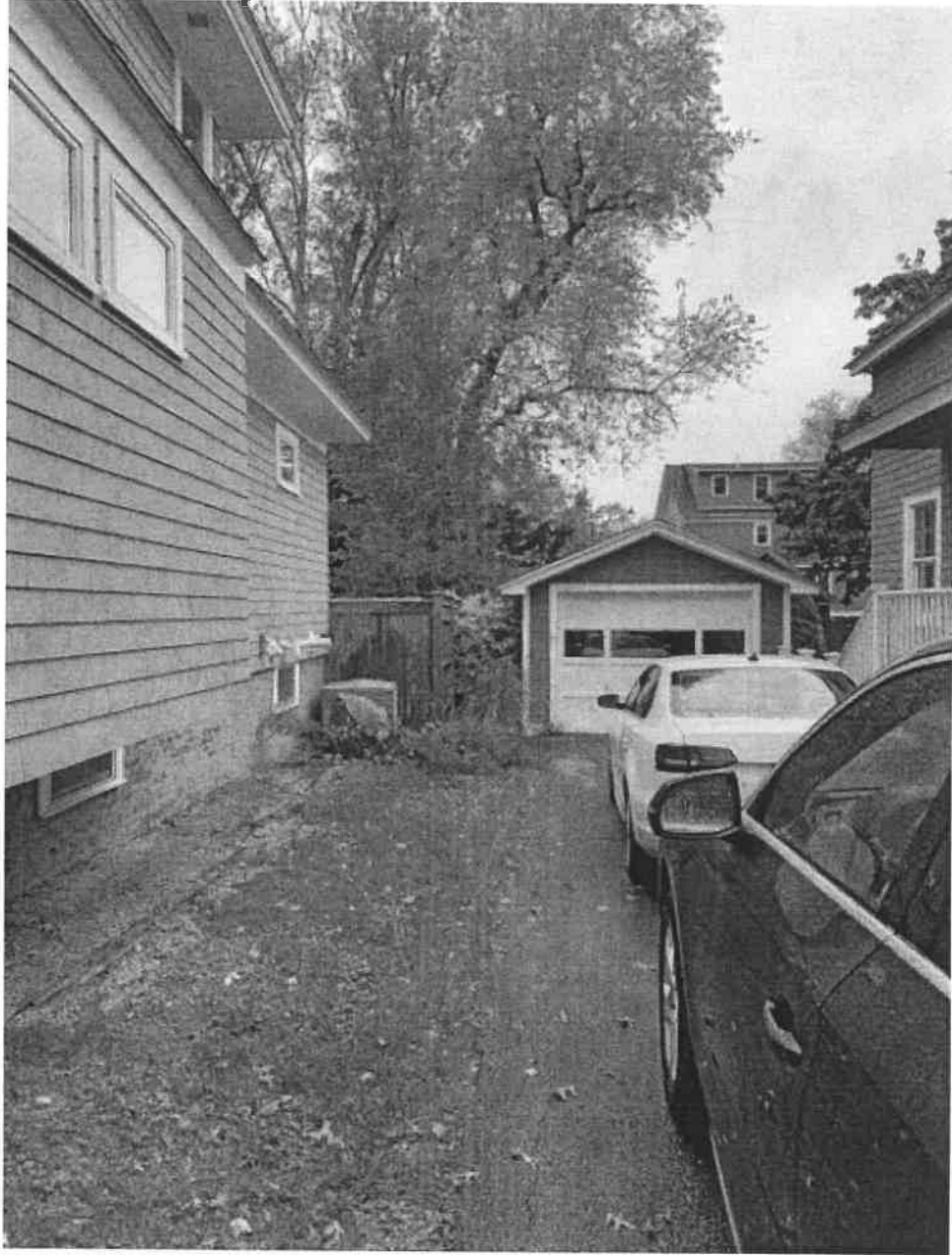

Exh. 9



Exh. 9



Exh. 9
6.4x3



Richards Ave.

Exh. 10

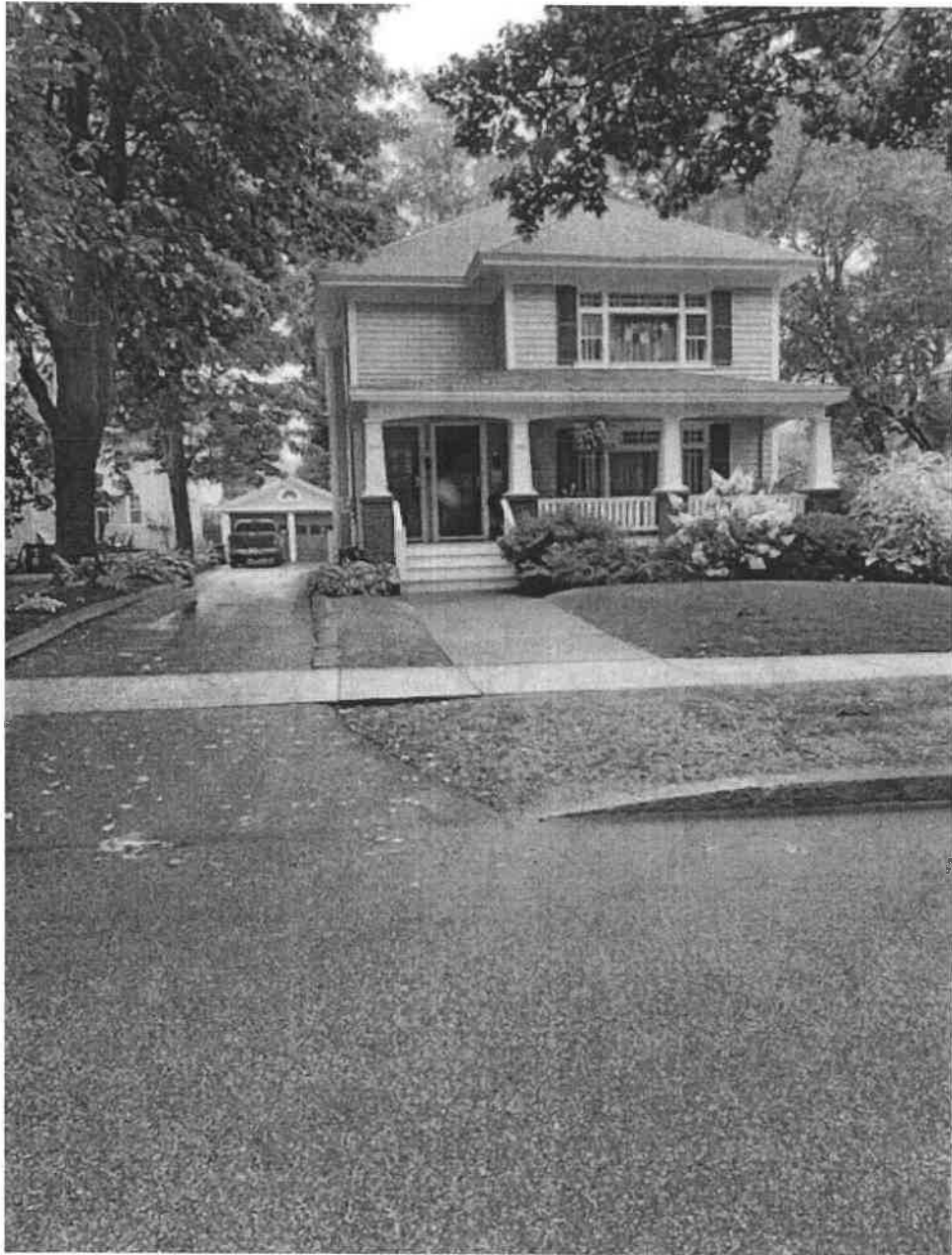

Richards Ave.

Exh. 10



Richards Ave.

Exh. 10



Richards Ave.

Exh. 10



Richards Ave.

Exh. 10



Richards Ave.

Exh. 10



Richards Ave.

Exh. 10



Richards Ave.

Exh. 10

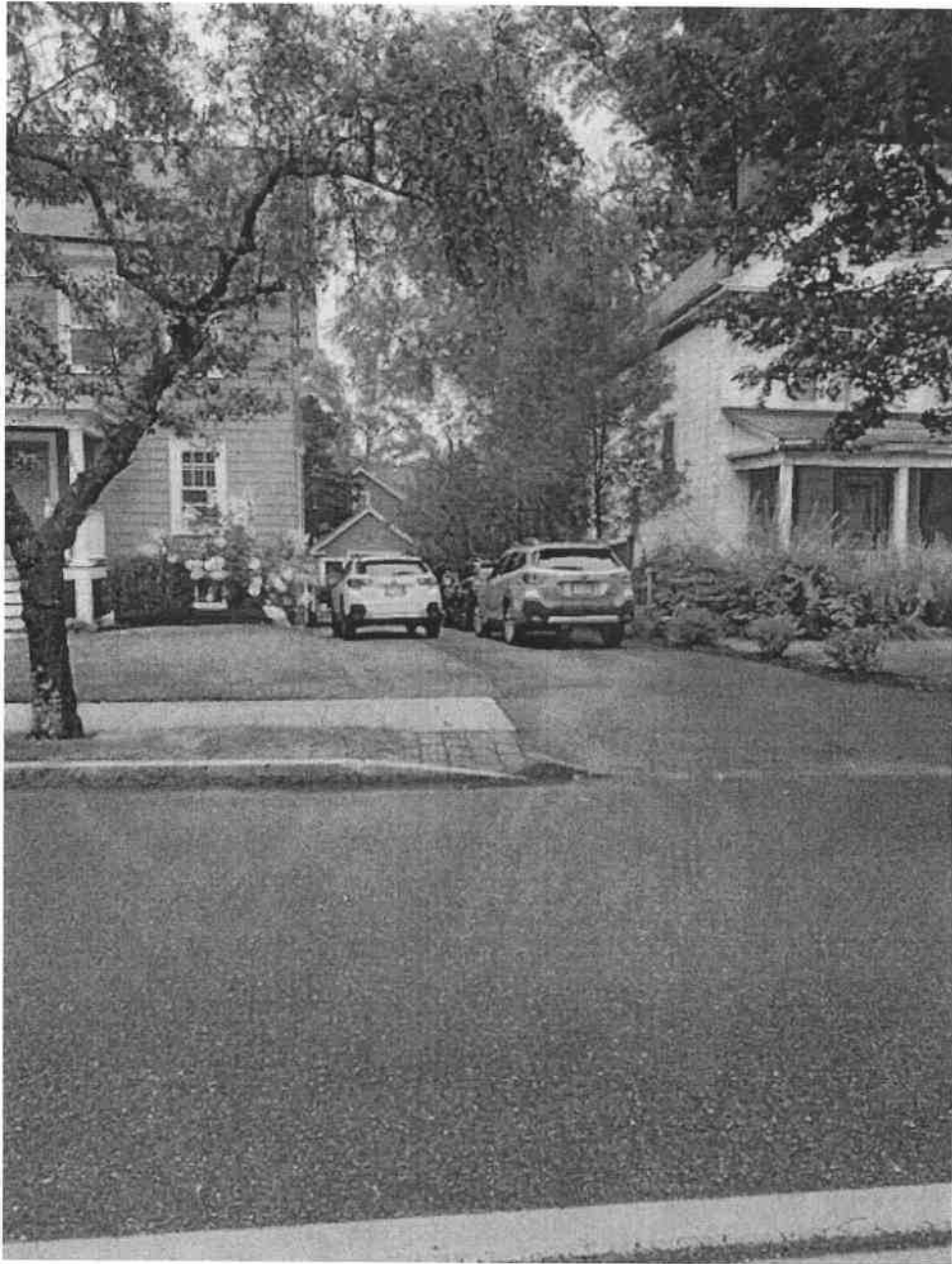

Miller Ave.

Exh. 10



Miller Ave.

Exh. 10

LIST OF ABUTTERS

Applicant: Paula J. Reid, Trustee of the Paula J. Reid 2003 Revocable Trust
 410 Richards Avenue, Portsmouth, NH
 Tax Map 112, Lot 10

<u>Property Address</u>	<u>Tax Map/Lot No.</u>	<u>Owner(s)</u>	<u>RCRD Deed Ref.</u>
420 Richards Avenue	Map 112, Lot 9	Amy E. Dutton Rev. Trust of 2003, Amy E. Dutton Murphy, Trustee	5225/39
390 Richards Avenue	Map 112, Lot 11	Stebbins Family Trust, John R. & Bridget M. Stebbins, Trustees	5636/563
399 Richards Avenue	Map 112, Lot 18	Barbara E. Collier Rev. Trust, Barbara E. Collier, Trustee	6315/246
409 Richards Avenue	Map 112, Lot 19	Stephen C. Buzzell Rev. Trust, Stephen C. Buzzell, Trustee, and and Jody E. Buzzell Rev. Trust, Jody E. Buzzell, Trustee	6035/840
419 Richards Avenue	Map 112, Lot 20	Thomas A. Nies Rev. Trust of 2010 and Denise M. Nies Rev. Trust of 2010, Thomas A. & Denise M. Nies, Trustees	5192/1225
295 Miller Avenue	Map 130, Lot 9	Kristen B. Mullen Rev. Living Trust, Kristen B. Mullen, Trustee	5699/1271
303 Miller Avenue	Map 130, Lot 10	The Twombly Trust, Dorothy C. Twombly, Trustee	2762/2766

Engineer/Surveyor:
 Kevin M. McEneaney
 McEneaney Survey Associates of New England
 P. O. Box 681
 Dover, NH 03821

Architect:
 Aimee Bentley
 ASB Architecture
 260 Main Street
 West Newbury, MA 01985

Attorney:
 Christopher A. Wyskiel
 Wyskiel, Boc, Tillinghast & Bolduc, P. A.
 561 Central Avenue
 Dover, NH 03820