

II. OLD BUSINESS

- A.** The request of **635 Sagamore Development LLC (Owner)**, for property located at **635 Sagamore Avenue** whereas relief is needed to remove existing structures and construct 4 single family dwellings which requires the following: 1) A Variance from Section 10.513 to allow four free-standing dwellings where one is permitted. 2) A Variance from Section 10.521 to allow a lot area per dwelling unit of 21,198 square feet per dwelling where 43,560 square feet is required. Said property is located on Assessor Map 222 Lot 19 and lies within the Single Residence A (SRA) District.

Existing & Proposed Conditions

	<u>Existing</u>	<u>Proposed</u>	<u>Permitted / Required</u>
<u>Land Use:</u>	Commercial w/ 1 apartment	4 single family dwellings	Primarily residential
<u>Lot area (sq. ft.):</u>	84,795	84,795	43,560 min.
<u>Lot Area per Dwelling Unit (sq. ft.):</u>	84,795	21,198	43,560 min.
<u>Lot depth (ft.):</u>	358	358	200 min.
<u>Street Frontage (ft.):</u>	160	160	150 min.
<u>Primary Front Yard (ft.):</u>	28	>30	30 min.
<u>Right Yard (ft.):</u>	60	>20	20 min.
<u>Left Yard (ft.):</u>	30	21	20
<u>Rear Yard (ft.):</u>	219	>40	40 min.
<u>Height (ft.):</u>	<35	<35	35 max.
<u>Building Coverage (%):</u>	4	9.2	10 max.
<u>Open Space Coverage (%):</u>	>50	81	50 min.
<u>Parking:</u>	4+	16	6
<u>Estimated Age of Structure:</u>	1950	Variance request(s) shown in red.	

Other Permits/Approvals Required

- TAC/Planning Board – Site Plan Review

Neighborhood Context

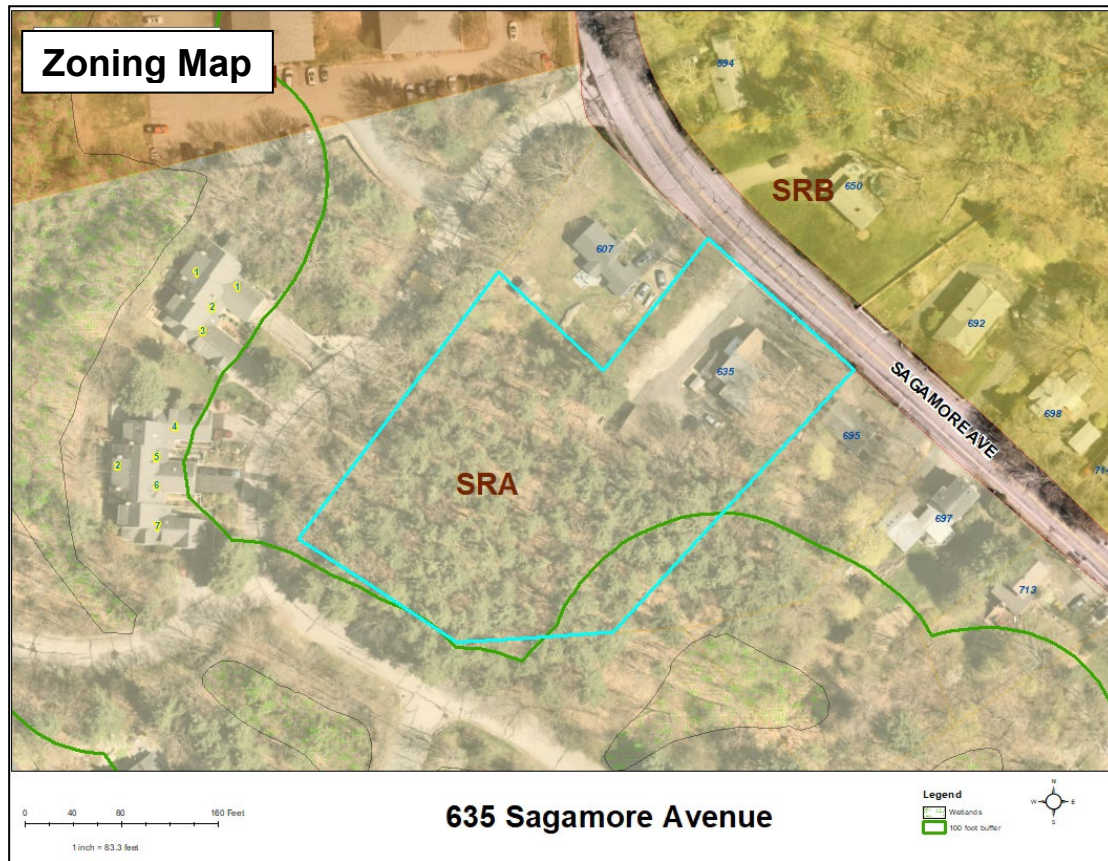
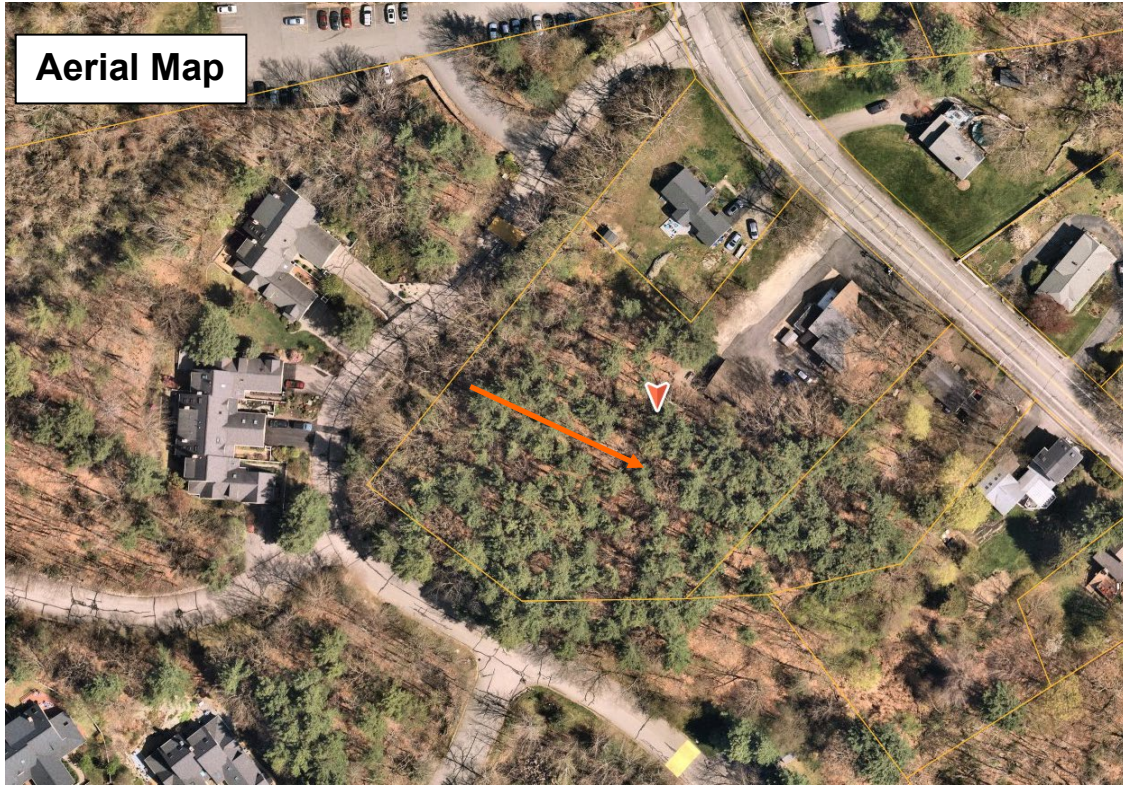

Previous Board of Adjustment Actions

April 19, 2022 – The BOA considered your application for remove existing commercial structure and construct 5 new single-family dwellings which requires the following: 1) A Variance from Section 10.513 to allow 5 principal structures on a lot where only 1 is permitted. 2) A Variance from Section 10.521 to allow a lot area per dwelling unit of 22,389 square feet where 1 acre per dwelling is required. The Board granted your request to **postpone** to the May meeting.

May 17, 2022 – The Board **granted** a request to postpone to the June meeting.

June 22, 2022 – The Board voted to acknowledge the **withdrawal** of the application.

November 15, 2022 - The Board **granted** a request to postpone to the June meeting.

December 20, 2022 - The Board **granted** a request to postpone to the June meeting.

January 17, 2023 - The Board **granted** a request to postpone to the March meeting.

Planning Department Comments

As shown in the history above, the applicant was before the Board this past spring with a proposal to construct 5 single family dwellings on one lot. Due to concerns from the abutters, the application was withdrawn so they could work on addressing concerns from the abutters. The new application proposes to demolish the existing structures and construct 4 free-standing single-family dwellings. The SRA zone requires 1 acre per dwelling unit and only allows 1 principal structure on a single lot. With 4 dwellings, the proposed lot area per dwelling will be 21,198, where 43,560 is required. With the exception of the density, all other dimensional requirements are in compliance with the proposed layout. This will require site plan review before TAC and Planning Board if the variances are granted. If granted approval, staff recommends the following stipulation for consideration:

1. **The design and location of the dwellings may change as a result of Planning Board review and approval.**

Review Criteria

This application must meet all five of the statutory tests for a **variance** (see Section 10.233 of the Zoning Ordinance):

1. *Granting the variance would not be contrary to the public interest.*
2. *Granting the variance would observe the spirit of the Ordinance.*
3. *Granting the variance would do substantial justice.*
4. *Granting the variance would not diminish the values of surrounding properties.*
5. *The “unnecessary hardship” test:*
 - (a) *The property has special conditions that distinguish it from other properties in the area.*

AND

 - (b) *Owing to these special conditions, a fair and substantial relationship does not exist between the general public purposes of the Ordinance provision and the specific application of that provision to the property; and the proposed use is a reasonable one.*

OR

 - (c) *Owing to these special conditions, the property cannot be reasonably used in strict conformance with the Ordinance, and a variance is therefore necessary to enable a reasonable use of it.*

10.235 Certain Representations Deemed Conditions

Representations made at public hearings or materials submitted to the Board by an applicant for a special exception or variance concerning features of proposed buildings, structures, parking or uses which are subject to regulations pursuant to Subsection 10.232 or 10.233 shall be deemed conditions upon such special exception or variance.

HOEFLE, PHOENIX, GORMLEY & ROBERTS, PLLC
ATTORNEYS AT LAW

127 Parrott Avenue, P.O. Box 4480 | Portsmouth, NH, 03802-4480
Telephone: 603.436.0666 | Facsimile: 603.431.0879 | www.hpgrlaw.com

October 26, 2022

HAND DELIVERED

Peter Stith, Principal Planner
Portsmouth Zoning Board of Adjustment
1 Junkins Avenue
Portsmouth, NH 03801

Re: 635 Sagamore Development, LLC, Owner/Applicant
Project Location: 635 Sagamore Avenue
Tax Map 222, Lot 19
General Residence A (GRA Zone)

Dear Mr. Stith and Zoning Board Members:

On behalf of 635 Sagamore Development, LLC, applicant, enclosed please find the following documents in support of a request for zoning relief:

- Portsmouth Land Use Application uploaded to Viewpoint today.
- Owner Authorization.
- 10/26/2022 – Memorandum and exhibits in support of zoning relief.

Very truly yours,



R. Timothy Phoenix
Monica F. Kieser

Enclosures

cc 635 Sagamore Development, LLC
Jones & Beach Engineers, Inc.
Artform Architecture, Inc.

DANIEL C. HOEFLE
R. TIMOTHY PHOENIX
LAWRENCE B. GORMLEY
STEPHEN H. ROBERTS

R. PETER TAYLOR
KEVIN M. BAUM
GREGORY D. ROBBINS
MONICA F. KIESER

JACOB J.B. MARVELLEY
DUNCAN A. EDGAR
STEPHANIE J. JOHNSON

OF COUNSEL:
SAMUEL R. REID
JOHN AHLGREN

Letter of Authorization

635 Sagamore Development, LLC, owner of property located at 635 Sagamore Avenue in Portsmouth, NH, known as Tax Map 222, Lot 19, do hereby authorize Jones & Beach Engineers, Inc. ("JBE"), Garrepy Planning Consultants, LLC ("GPC"), and Hoefle, Phoenix, Gormley & Roberts, PLLC ("HPGR") to act on its behalf concerning the previously mentioned property.

I hereby appoint JBE, GPC and HPGR as agents to act on behalf of 635 Sagamore Development, LLC in the Planning Board and Zoning Board application process, to include any required signatures.

635 Sagamore Development, LLC

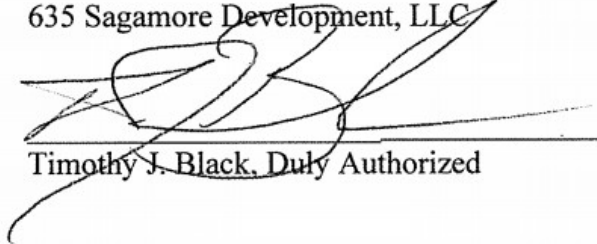
A handwritten signature in black ink, appearing to read 'Timothy J. Black', is written over a horizontal line. The signature is stylized and somewhat illegible.

Timothy J. Black, Duly Authorized

January 5, 2022
Date

MEMORANDUM

To: Portsmouth Zoning Board of Adjustment (“ZBA”)
From: R. Timothy Phoenix, Esq.
Monica F. Kieser, Esq.
Date: October 26, 2022
Re: 635 Sagamore Development, LLC, Owner/Applicant
Project location: 635 Sagamore Avenue
Tax Map 222, Lot 19
Single Residence A (SRA) District

Dear Chairman Parrott and Zoning Board Members:

On behalf of 635 Sagamore Development, LLC (“635 Sagamore” or “Applicant”) we are pleased to submit this memorandum and the attached exhibits in support of zoning relief to be considered by the ZBA at its November 15, 2022 meeting.

I. EXHIBITS

- A. Plan Set – by Jones and Beach Engineers
 - C1 – Existing Conditions Plan
 - C2 – ZBA Site Plan
 - C3 – Topographic Site Plan
- B. Architectural Elevations and Floor Plans-by ArtForm Architecture, Inc.
 - Renderings
 - First Floor
 - Second Floor
 - Foundation Plan
 - Elevations
- C. Site photographs
- D. Tax Assessors Card
- E. City GIS Map – identifying nearby zoning districts and surrounding area

II. PROPERTY/BACKGROUND

635 Sagamore Avenue is an 84,795 s.f lot with 150 ft. of frontage containing two buildings in poor condition; the front building contains Luster King, an automobile detailing shop and upstairs apartment, and behind a large service garage (the “Property”). The Luster King building is located partially within the front yard setback, access to it is over the entire frontage, and the use of the Property does not conform to the requirements of the Single Residence A District. 635 Sagamore proposes to remove the existing commercial building and garage and redevelop the Property with four new single-family homes with access via a private roadway from Sagamore Avenue (the “Project”). **(Exhibit A)**. The Project is more compatible

with the neighborhood which includes the westerly abutter, Tidewatch Condominiums with 122 Units, and the Sagamore Court Condominium with 144 Units. **(Exhibit D)**. Other nearby abutters are largely developed with single family residences with similar density as the proposed project. The Luster King building is still served by septic, but municipal sewer service has been extended to the Property which will serve the proposed dwellings.

In March of this year, 635 Sagamore filed a variance application seeking relief from §10.513 and §10.521 (Dimensional Table) to permit five dwellings on the Property where one dwelling is required and 16,959 s.f. per dwelling unit where 43,560 s.f. per dwelling is required. Thereafter, Tidewatch Condominium Association (“Tidewatch”) objected, through Counsel Brian Bouchard. 635 Sagamore withdrew the previous application in order to spend time working with Tidewatch to address its concerns. 635 Sagamore now proposes a twenty percent (20%) reduction four-unit residential development which retains a significant tree buffer and adds a mix of trees on the south and west side of the lot (the “Revised Project”). Given the reduction in units and generous plantings, Tidewatch Condominium Association has withdrawn its objection to the Revised Project, provided 635 Sagamore continues to coordinate with Tidewatch on issues related to landscaping and stormwater management.

The Revised Project requires similar relief as before as four dwelling units are proposed on a ±1.947 acre lot (2.06 units per acre or 21,198 s.f. per dwelling). This density is less than nearby densely developed Sagamore Court Condominium (144 units/15.01 acre = 9.59 units per acre or 4,542 s.f. per dwelling) to the north and Tidewatch Condominium (122 units/53.59 acre = 2.27 units per acre or 19,189 s.f. per dwelling) directly to the west. Notably, the SRB Zone, located across Sagamore Avenue, permits a lot area of 15,000 square feet per dwelling unit or approximately 2.9 units per acre. The proposal at 21,198 s.f. square feet per unit falls between the single-family homes opposite the lot and the more densely developed condominium associations. Thus, in addition to cleaning up a long distressed and non-conforming site, including narrowing the current open frontage curb cut, the proposal creates a natural transition between the SRB Zone across Sagamore, the existing multi-building condominium developments to the north and west (rear) of the Property and the nearby single-family home lots.

III. RELIEF REQUIRED

The Project meets setback, lot coverage, and open space requirements. **(Exhibit A)**. Relief is required to allow the proposed structures on a single lot and for lot area per dwelling unit.

- 1.) **PZO §10.513 One Freestanding Dwelling/Lot** – to permit four dwellings on a 1.947 acre lot.
- 2.) **PZO §10.521 (Table of Dimensional Standards) Lot Area Per Dwelling Unit** – to permit four dwellings on 1.947 acres (21,198 s.f./dwelling area) where 43,560 s.f. is required for each dwelling.

IV. VARIANCE REQUIREMENTS

1. **The variance will not be contrary to the public interest**
2. **The spirit of the ordinances observed**

The first step in the ZBA's analysis is to determine whether granting a variance is not contrary to the public interest and is consistent with the spirit and intent of the ordinance, considered together pursuant to Malachy Glen Associates, Inc v. Town of Chichester, 155 NH 102 (2007) and its progeny. Upon examination, it must be determined whether granting a variance "would unduly and to a marked degree conflict with the ordinance such that it violates the ordinances basic zoning objectives." Id. "Mere conflict with the ordinance is not enough." Id.

The Portsmouth Zoning Ordinance was enacted for the general purpose (PZO§10.121) of promoting the health, safety and welfare in accordance with the Master plan by regulating:

1. **The use of land, buildings and structures for business, industrial, residential and other purposes** – The Property currently houses a non-conforming commercial auto detailing business and service garage. **(Exhibit C)**. The proposal would replace those buildings with brand new, to code, residences consistent with surrounding uses.
2. **The intensity of land use, including lot sizes, building coverage, building height and bulk, yards and open space** – The Project complies with building coverage, height, yards and open space requirements. The reduced proposal with four dwellings on a single lot, at 2.06 dwelling units per acre is consistent with surrounding properties and less than the density permitted by right across Sagamore Avenue.
3. **The design of facilities for vehicular access, circulation, parking and loading-** The Project will be served by a private roadway from Sagamore Avenue. **(Exhibit A)**. There is currently no defined curb cut on the property so the redevelopment will improve driveway distances, site lines, and overall traffic safety from the Property compared to the existing commercial and residential use. **(Exhibit D)**. The driveway will undergo further review as part of the Planning Board and NHDOT review processes.

4. The impacts on properties of outdoor lighting, noise, vibration, stormwater runoff and flooding – The Property is currently used as a commercial auto detailing facility in the middle of a residential area. The Project will convert the Property to residential use with lighting, noise, and other conditions more appropriate for the neighborhood. A generous buffer will be preserved between the Project and Tidewatch Condominium. The Project maintains 81.3% open space. Stormwater runoff will be improved over the current development which is significantly paved and use of commercial cleaning chemicals will cease.
5. The preservation and enhancement of the visual environment – The Project vastly improves the visual environment for the immediate abutters on either side and across the street. In addition, a generous vegetated buffer is retained for the south/west abutters. Sagamore further screens the developed area with the addition of a significant tree buffer. **(Exhibit A)**.
6. The preservation of historic districts buildings and structures of historic or architectural interest – The Property and the existing structures to be removed are of no known historic or architectural interest.
7. The protection of natural resources, including groundwater, surface water, wetlands, wildlife habitat and air quality – The Project will significantly improve conditions by terminating the use of commercial grade cleaning chemicals in favor of a compatible residential uses served by municipal sewer.

In considering whether variances "in a marked degree conflict with the ordinance such that they violate the ordinances basic zoning objectives." Malachy Glen, supra, the New Hampshire Supreme Court also held:

One way to ascertain whether granting the variance would violate basic zoning objectives is to examine whether it would alter the essential character of the locality. Another approach to [determine] whether granting the variance violates basic zoning objectives is to examine whether granting the variance would threaten the public health, safety or welfare. (Emphasis Added)

The Property is located on a busy street in a densely developed residential area. While there are some other nearby commercial use properties, they are located closer to Sagamore Creek in the Waterfront Business Zone, are largely less impactful and are more buffered from nearby residences than the current business operations on the Property. The Project would convert a long-standing commercial use that is grossly incompatible with the character of the locality to a residential use consistent with the surrounding area including two large condominium developments. The commercial traffic and the use of commercial grade cleaning chemicals will cease, thus improving the public health, safety and welfare. The wide open curb

cut accessing the lot will be reduced to a controlled entry/exit. The Project creates a natural transition between these condominium developments and the adjoining GRB zone. Thus, permitting four code compliant, single-family dwellings on ±1.947 acres does not alter the essential character of the locality nor will it threaten the public health, safety or welfare.

3. Granting the variances will not diminish surrounding property values

The commercial buildings currently located on the Property are distressed, incongruent with the surrounding residential neighborhood and frankly an eyesore. The Project cleans up the site, removes commercial buildings/uses and replaces them with brand new tastefully designed residences. In consultation with Tidewatch, a generous vegetated buffer is retained, which is supplemented by the addition of a robust landscape buffer plan. Given the termination of the commercial use, removal of the distressed structures, and efforts to screen the residential structures, the Project will increase the value of surrounding properties. Accordingly, this element of the variance criteria is satisfied.

4. Denial of the variances results in an unnecessary hardship

a. Special conditions distinguish the property/project from others in the area-

This portion of the SRA District on the north side of Sagamore Creek is comprised of only seven properties. **(Exhibit E)**. Discounting Tidewatch with 122 units on 53.59 acres, the 1.947 acre L-shaped lot significantly larger than the remaining five properties, yet contains just over the required frontage. Although zoned SRA and subject to a 43,560 s.f. minimum lot area and lot area/dwelling unit requirement, this neighborhood is bounded by the Sagamore Condominium Development with 144 Units on 15.01 acres, a handful of lots in the Waterfront Business District, and the SRB district across Sagamore Avenue with its reduced density requirement of just 15,000 s.f./dwelling unit. See Walker v. City of Manchester, 107 N.H. 382, 386 (1966) (hardship may be found where similar nonconforming uses exist within the neighborhood and the proposed use will have no adverse effect on the neighborhood). The parcel size, shape, and location near other densely developed residential parcels combine to create special conditions.

b. No fair and substantial relationship exists between the general public purposes of the ordinance and its specific application in this instance.

The purpose of the requirements for one free standing dwelling per lot and lot area per dwelling unit is to prohibit overcrowding, allow for air, light, and separation between neighbors,

and to permit stormwater treatment. The Project meets all lot area, building and open space coverage, height and external setback requirements. Additionally, the proposal provides for voluntary setbacks between each of the four new buildings of at least 20 feet, consistent with the side setback requirement for the district. Thus, adequate area for air, light, separation between neighbors and stormwater treatment is provided. The proposed density is also consistent with the surrounding area, which includes many smaller sized lots with homes located in relatively close proximity. **(Exhibit E)**. Moreover, granting the requested variances will significantly improve the Property and surrounding area by removing two blighted, non-conforming commercial structures and replacing them with four brand new, homes where housing is sorely needed. The Property will be completely redeveloped, thus it follows that there is no reason to apply the strict requirements of the ordinance. This transitional location, located near and adjoining two densely development condominiums and across Sagamore Avenue from the SRB Zone is well suited for the proposed four building single-family development.

c. The proposed use is reasonable

If the use is permitted, it is deemed reasonable. Vigeant v. Hudson, 151 NH 747 (2005). The proposal is a residential use in a residential zone and thus is reasonable. Accordingly denial would result in an unnecessary hardship.

5. Substantial justice will be done by granting the variance.

If “there is no benefit to the public that would outweigh the hardship to the applicant” this factor is satisfied. Harborside Associates, L.P. v. Parade Residence Hotel, LLC, 162 N.H. 508 (2011). That is, “any loss to the [applicant] that is not outweighed by a gain to the general public is an injustice.” Malachy Glen, supra at 109.

“The right to use and enjoy one's property is a fundamental right protected by both the State and Federal Constitutions.” N.H. CONST. pt. I, arts. 2, 12; U.S. CONST. amends. V, XIV; Town of Chesterfield v. Brooks, 126 N.H. 64 (1985) at 68. Part I, Article 12 of the New Hampshire Constitution provides in part that “no part of a man's property shall be taken from him, or applied to public uses, without his own consent, or that of the representative body of the people.” Thus, our State Constitutional protections limit the police power of the State and its municipalities in their regulation of the use of property. L. Grossman & Sons, Inc. v. Town of Gilford, 118 N.H. 480, 482 (1978). “Property” in the constitutional sense has been interpreted to

mean not the tangible property itself, *but rather the right to possess, use, enjoy and dispose of it.* Burrows v. City of Keene, 121 N.H. 590, 597 (1981) (emphasis added). Sagamore is constitutionally entitled to the use of the lot as it sees fit subject only to the effect of the lot size and density requirements.

The Project: removes blighted buildings and a nonconforming commercial use; complies with all other dimensional requirements; maintains generous open space and vegetated buffers; provides additional screening with a robust planting plan, there will be no benefit to the public from denial and no harm to the public by granting the variances. Conversely, denial of the variances causes great harm to 635 Sagamore and its abutters by continuing the nonconforming commercial use of the Property. Accordingly, substantial justice is done by granting the variances.

V. CONCLUSION

For all of the reasons herein stated, Sagamore respectfully requests that the Portsmouth Zoning of Adjustment grant the requested variances.

Respectfully submitted,
635 Sagamore Development, LLC

By:

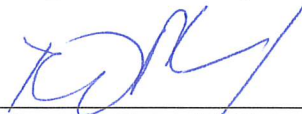

R. Timothy Phoenix, Esq.
Monica F. Kieser, Esq.

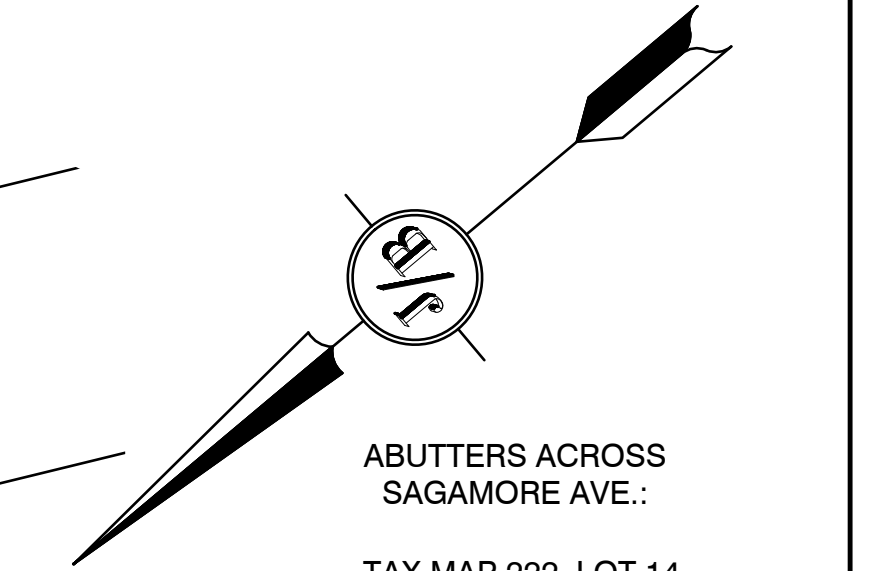
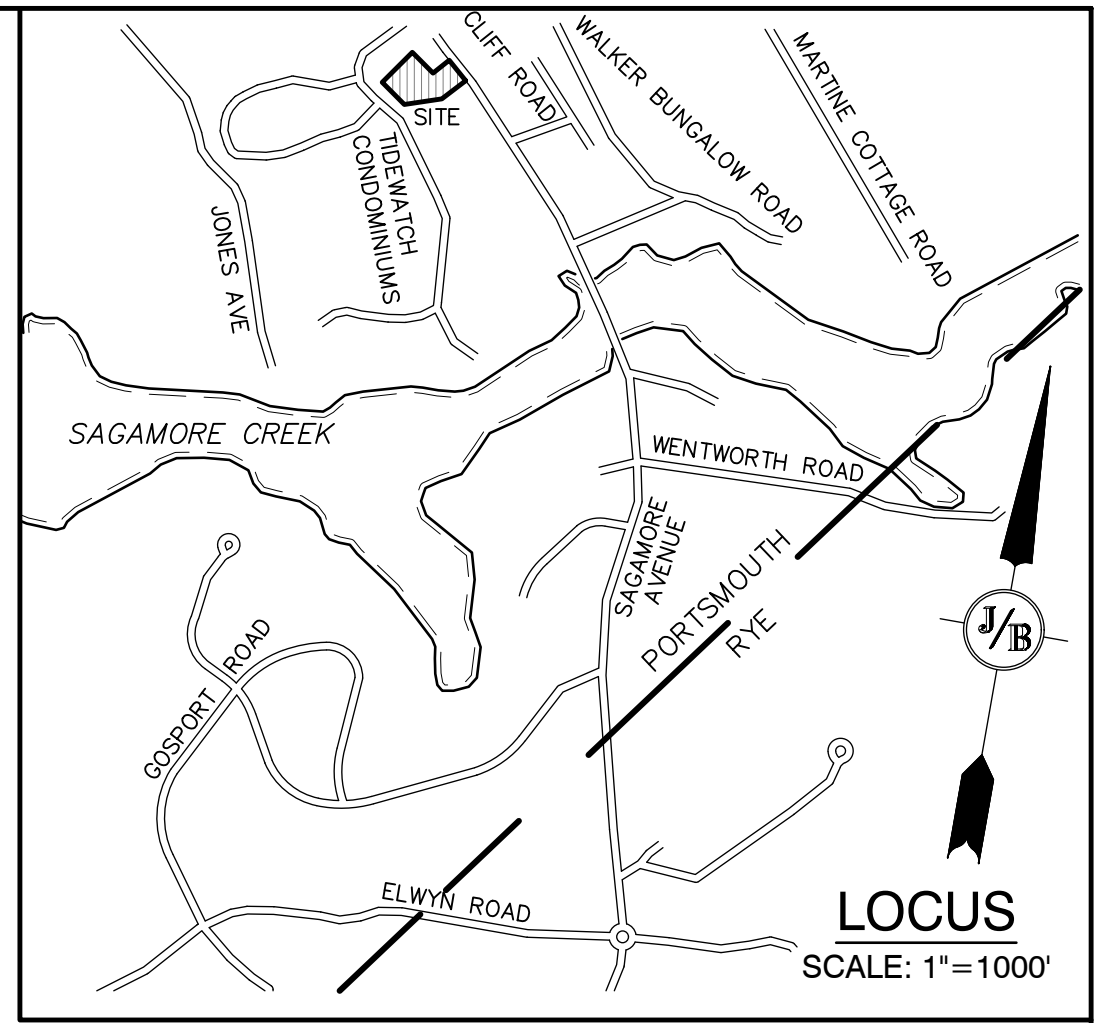
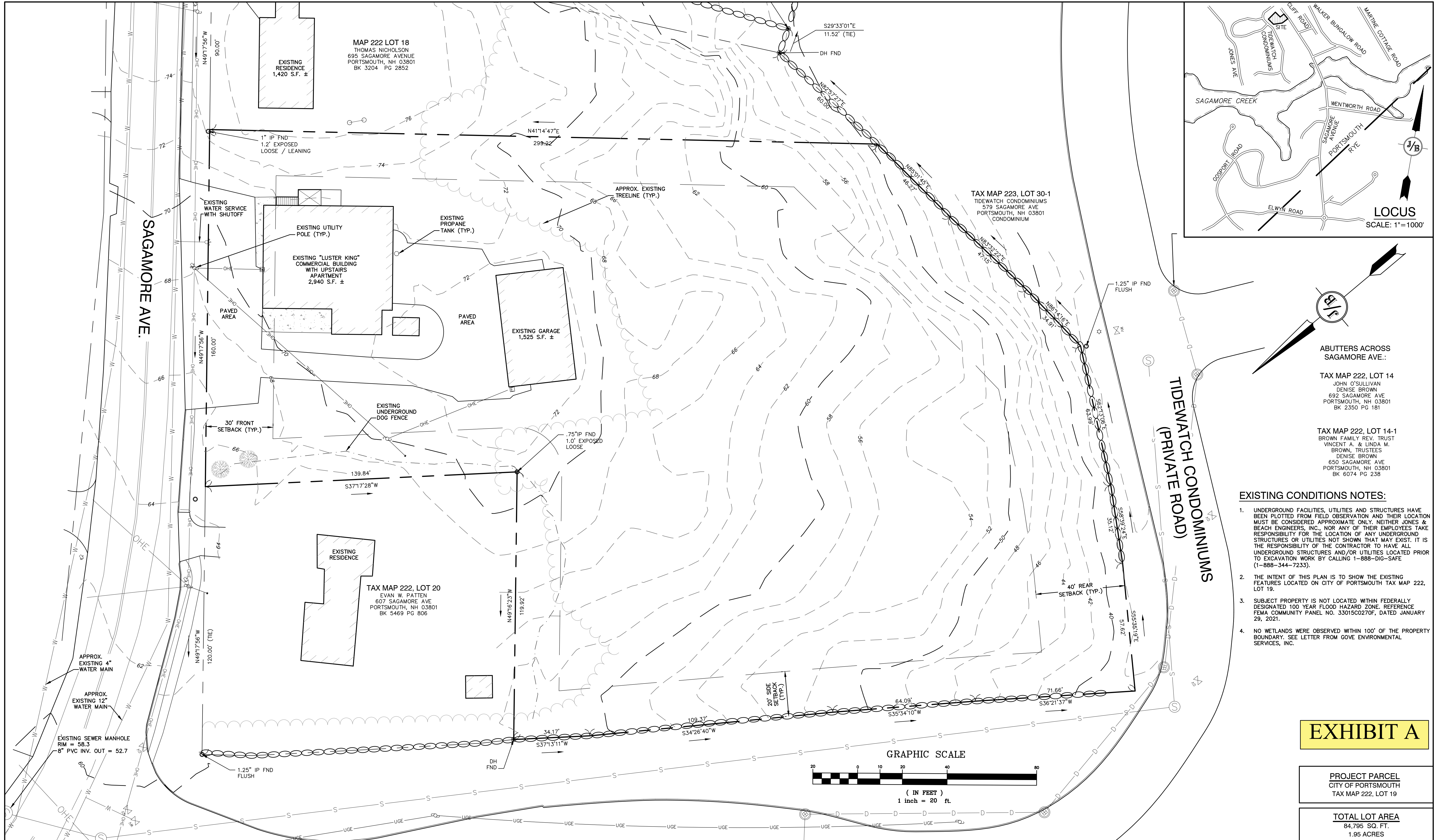

ABUTTERS ACROSS SAGAMORE AVE.:

TAX MAP 222, LOT 14
 JOHN O'SULLIVAN
 DENISE BROWN
 692 SAGAMORE AVE
 PORTSMOUTH, NH 03801
 BK 2350 PG 181

TAX MAP 222, LOT 14-1
 BROWN FAMILY REV. TRUST
 VINCENT A. & LINDA M.
 BROWN, TRUSTEES
 DENISE BROWN
 650 SAGAMORE AVE
 PORTSMOUTH, NH 03801
 BK 6074 PG 238

- EXISTING CONDITIONS NOTES:**
- UNDERGROUND FACILITIES, UTILITIES AND STRUCTURES HAVE BEEN PLOTTED FROM FIELD OBSERVATION AND THEIR LOCATION MUST BE CONSIDERED APPROXIMATE ONLY. NEITHER JONES & BEACH ENGINEERS, INC., NOR ANY OF THEIR EMPLOYEES TAKE RESPONSIBILITY FOR THE LOCATION OF ANY UNDERGROUND STRUCTURES OR UTILITIES NOT SHOWN THAT MAY EXIST. IT IS THE RESPONSIBILITY OF THE CONTRACTOR TO HAVE ALL UNDERGROUND STRUCTURES AND/OR UTILITIES LOCATED PRIOR TO EXCAVATION WORK BY CALLING 1-888-DIG-SAFE (1-888-344-7233).
 - THE INTENT OF THIS PLAN IS TO SHOW THE EXISTING FEATURES LOCATED ON CITY OF PORTSMOUTH TAX MAP 222, LOT 19.
 - SUBJECT PROPERTY IS NOT LOCATED WITHIN FEDERALLY DESIGNATED 100 YEAR FLOOD HAZARD ZONE. REFERENCE FEMA COMMUNITY PANEL NO. 33015C0270F, DATED JANUARY 29, 2021.
 - NO WETLANDS WERE OBSERVED WITHIN 100' OF THE PROPERTY BOUNDARY. SEE LETTER FROM GOVE ENVIRONMENTAL SERVICES, INC.

EXHIBIT A

PROJECT PARCEL
 CITY OF PORTSMOUTH
 TAX MAP 222, LOT 19

TOTAL LOT AREA
 84,795 SQ. FT.
 1.95 ACRES

Design: JAC Draft: DJM Date: 12/07/2021
 Checked: JAC Scale: AS NOTED Project No.: 18134.1
 Drawing Name: 18134-CONCEPT-8.dwg

THIS PLAN SHALL NOT BE MODIFIED WITHOUT WRITTEN PERMISSION FROM JONES & BEACH ENGINEERS, INC. (JBE). ANY ALTERATIONS, AUTHORIZED OR OTHERWISE, SHALL BE AT THE USER'S SOLE RISK AND WITHOUT LIABILITY TO JBE.

REV.	DATE	REVISION	BY
6	10/25/22	REVISED PLAN NAME	DJM
5	6/23/22	REVISED CONCEPTUAL LAYOUT	DJM
4	6/2/22	ADDED UTILITY INFORMATION	DJM
3	3/21/22	REVISED CONCEPTUAL LAYOUT	DJM
2	2/10/22	REVISED CONCEPTUAL LAYOUT	DJM
REV.	DATE	REVISION	BY

Designed and Produced in NH

J/B Jones & Beach Engineers, Inc.

85 Portsmouth Ave. Civil Engineering Services 603-772-4746
 PO Box 219 Stratham, NH 03885 FAX: 603-772-0227
 E-MAIL: JBE@JONESANDBEACH.COM

Plan Name: **EXISTING CONDITIONS PLAN**

Project: **4-UNIT RESIDENTIAL SITE
 635 SAGAMORE AVE., PORTSMOUTH, NH**

Owner of Record: 3612 LAFAYETTE RD., DEPT 4, PORTSMOUTH, NH 03801 BK 6332 PG 1158

DRAWING No. **C1**

SHEET 1 OF 3
 JBE PROJECT NO. 18134.1

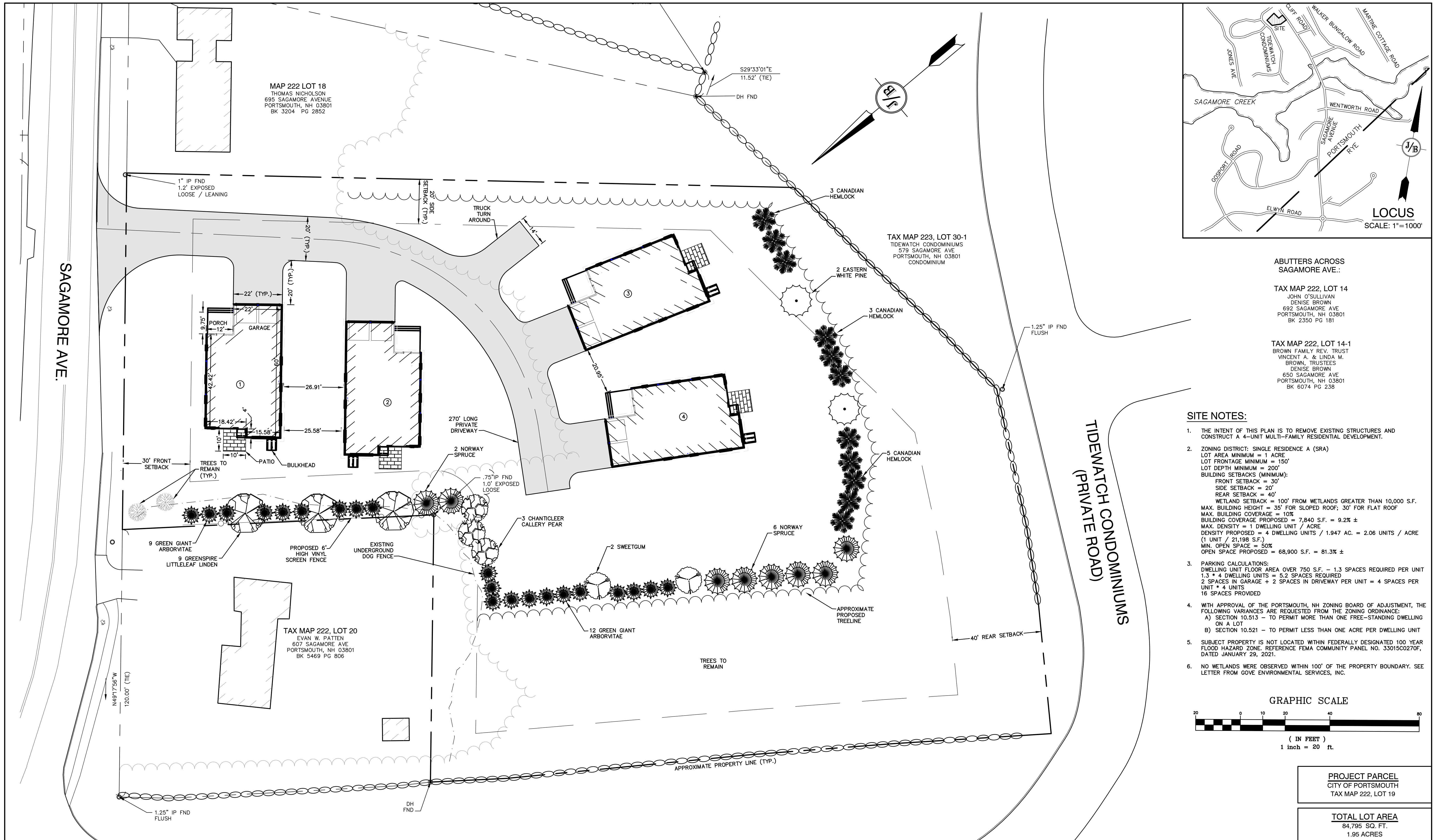

- SITE NOTES:**
- THE INTENT OF THIS PLAN IS TO REMOVE EXISTING STRUCTURES AND CONSTRUCT A 4-UNIT MULTI-FAMILY RESIDENTIAL DEVELOPMENT.
 - ZONING DISTRICT: SINGLE RESIDENCE A (SRA)
LOT AREA MINIMUM = 1 ACRE
LOT FRONTAGE MINIMUM = 150'
LOT DEPTH MINIMUM = 200'
BUILDING SETBACKS (MINIMUM):
FRONT SETBACK = 30'
SIDE SETBACK = 20'
REAR SETBACK = 40'
WETLAND SETBACK = 100' FROM WETLANDS GREATER THAN 10,000 S.F.
MAX. BUILDING HEIGHT = 35' FOR SLOPED ROOF; 30' FOR FLAT ROOF
MAX. BUILDING COVERAGE = 10%
BUILDING COVERAGE PROPOSED = 7,840 S.F. = 9.2% ±
MAX. DENSITY = 1 DWELLING UNIT / ACRE
DENSITY PROPOSED = 4 DWELLING UNITS / 1.947 AC. = 2.06 UNITS / ACRE (1 UNIT / 21,198 S.F.)
MIN. OPEN SPACE = 50%
OPEN SPACE PROPOSED = 68,900 S.F. = 81.3% ±
 - PARKING CALCULATIONS:
DWELLING UNIT FLOOR AREA OVER 750 S.F. - 1.3 SPACES REQUIRED PER UNIT
1.3 * 4 DWELLING UNITS = 5.2 SPACES REQUIRED
2 SPACES IN GARAGE + 2 SPACES IN DRIVEWAY PER UNIT = 4 SPACES PER UNIT * 4 UNITS
16 SPACES PROVIDED
 - WITH APPROVAL OF THE PORTSMOUTH, NH ZONING BOARD OF ADJUSTMENT, THE FOLLOWING VARIANCES ARE REQUESTED FROM THE ZONING ORDINANCE:
A) SECTION 10.513 - TO PERMIT MORE THAN ONE FREE-STANDING DWELLING ON A LOT
B) SECTION 10.521 - TO PERMIT LESS THAN ONE ACRE PER DWELLING UNIT
 - SUBJECT PROPERTY IS NOT LOCATED WITHIN FEDERALLY DESIGNATED 100 YEAR FLOOD HAZARD ZONE, REFERENCE FEMA COMMUNITY PANEL NO. 33015C0270F, DATED JANUARY 29, 2021.
 - NO WETLANDS WERE OBSERVED WITHIN 100' OF THE PROPERTY BOUNDARY. SEE LETTER FROM GOVE ENVIRONMENTAL SERVICES, INC.

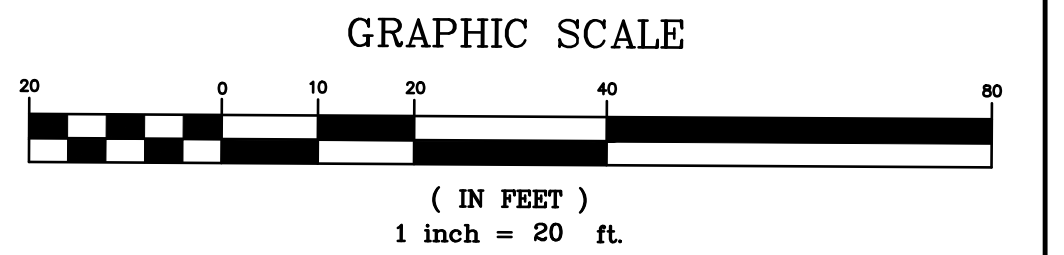

Design: JAC Draft: DJM Date: 12/07/2021
Checked: JAC Scale: AS NOTED Project No.: 18134.1
Drawing Name: 18134-CONCEPT-8.dwg
THIS PLAN SHALL NOT BE MODIFIED WITHOUT WRITTEN PERMISSION FROM JONES & BEACH ENGINEERS, INC. (JBE). ANY ALTERATIONS, AUTHORIZED OR OTHERWISE, SHALL BE AT THE USER'S SOLE RISK AND WITHOUT LIABILITY TO JBE.

REV.	DATE	REVISION	BY
6	10/25/22	REVISED PLAN NAME	DJM
5	6/23/22	REVISED CONCEPTUAL LAYOUT	DJM
4	6/2/22	ADDED UTILITY INFORMATION	DJM
3	3/21/22	REVISED CONCEPTUAL LAYOUT	DJM
2	2/10/22	REVISED CONCEPTUAL LAYOUT	DJM
REV.	DATE	REVISION	BY

Designed and Produced in NH

J/B Jones & Beach Engineers, Inc.

85 Portsmouth Ave. PO Box 219 Stratham, NH 03885

Civil Engineering Services

603-772-4746 FAX: 603-772-0227 E-MAIL: JBE@JONESANDBEACH.COM

Plan Name: **ZBA SITE PLAN**

Project: **4-UNIT RESIDENTIAL SITE 635 SAGAMORE AVE., PORTSMOUTH, NH**

Owner of Record: **3612 LAFAYETTE RD., DEPT 4, PORTSMOUTH, NH 03801 BK 6332 PG 1158**

DRAWING No. **C2**

SHEET 2 OF 3
JBE PROJECT NO. 18134.1

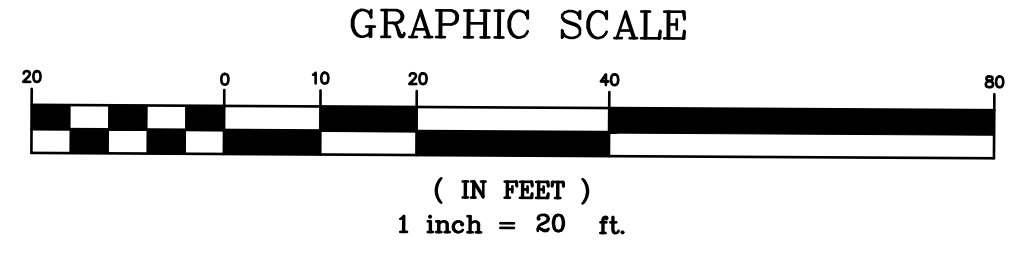
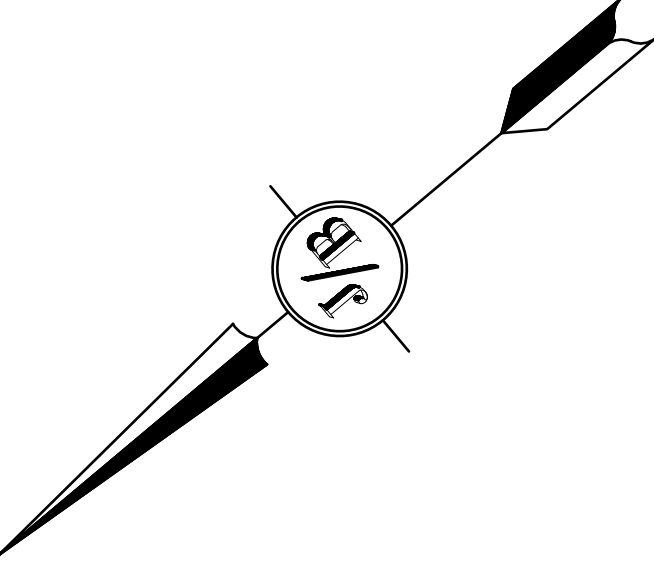

PROJECT PARCEL
 CITY OF PORTSMOUTH
 TAX MAP 222, LOT 19

TOTAL LOT AREA
 84,795 SQ. FT.
 1.95 ACRES

Design: JAC Draft: DJM Date: 12/07/2021
 Checked: JAC Scale: AS NOTED Project No.: 18134.1
 Drawing Name: 18134-CONCEPT-8.dwg

THIS PLAN SHALL NOT BE MODIFIED WITHOUT WRITTEN PERMISSION FROM JONES & BEACH ENGINEERS, INC. (JBE). ANY ALTERATIONS, AUTHORIZED OR OTHERWISE, SHALL BE AT THE USER'S SOLE RISK AND WITHOUT LIABILITY TO JBE.

REV.	DATE	REVISION	BY
6	10/25/22	REVISED PLAN NAME	DJM
5	6/23/22	REVISED CONCEPTUAL LAYOUT	DJM
4	6/2/22	ADDED UTILITY INFORMATION	DJM
3	3/21/22	REVISED CONCEPTUAL LAYOUT	DJM
2	2/10/22	REVISED CONCEPTUAL LAYOUT	DJM

Designed and Produced in NH

J/B Jones & Beach Engineers, Inc.

85 Portsmouth Ave. Civil Engineering Services 603-772-4746
 PO Box 219 Stratham, NH 03885 FAX: 603-772-0227
 E-MAIL: JBE@JONESANDBEACH.COM

Plan Name: **ZBA TOPOGRAPHIC SITE PLAN**

Project: **4-UNIT RESIDENTIAL SITE
 635 SAGAMORE AVE., PORTSMOUTH, NH**

Owner of Record: **3612 LAFAYETTE RD., DEPT 4, PORTSMOUTH, NH 03801 BK 6332 PG 1158**

DRAWING No.
C3
 SHEET 3 OF 3
 JBE PROJECT NO. 18134.1

1/27/2022

Sea Watch

419.126.v14 GL (1/27/2022)

©2011-2021 Art Form Architecture, Inc., all rights reserved . You may not build this design without purchasing a license, even if you make changes. This design may have geographic restrictions.



603-431-9559



Dear Builders and Home Buyers,

In addition to our Terms and Conditions (the "Terms"), please be aware of the following:

This design may not yet have Construction Drawings (as defined in the Terms), and is, therefore, only available as a Design Drawing (as defined in the Terms and together with Construction Drawings, "Drawings"). It is possible that during the conversion of a Design Drawing to a final Construction Drawing, changes may be necessary including, but not limited to, dimensional changes. Please see Plan Data Explained on www.ArtformHomePlans.com to understand room sizes, dimensions and other data provided. We are not responsible for typographical errors.

Artform Home Plans ("Artform") requires that our Drawings be built substantially as designed. Artform will not be obligated by or liable for use of this design with markups as part of any builder agreement. While we attempt to accommodate where possible and reasonable, and where the changes do not denigrate our design, any and all changes to Drawings must be approved in writing by Artform. It is recommended that you have your Drawing updated by Artform prior to attaching any Drawing to any builder agreement. Artform shall not be responsible for the misuse of or unauthorized alterations to any of its Drawings.

Facade Changes:

- To maintain design integrity, we pay particular attention to features on the front facade, including but not limited to door surrounds, window casings, finished porch column sizes, and roof friezes. While we may allow builders to add their own flare to aesthetic elements, we don't allow our designs to be stripped of critical details. Any such alterations require the express written consent of Artform.
- Increasing ceiling heights usually requires adjustments to window sizes and other exterior elements.

Floor plan layout and/or Structural Changes:

- Structural changes always require the express written consent of Artform
- If you wish to move or remove walls or structural elements (such as removal of posts, increases in house size, ceiling height changes, addition of dormers, etc), please do not assume it can be done without other additional changes (even if the builder or lumber yard says you can).

1/27/2022

Sea Watch

419.126.v14 GL (1/27/2022)

©2011-2021 Art Form Architecture, Inc., all rights reserved . You may not build this design without purchasing a license, even if you make changes. This design may have geographic restrictions.



603-431-9559



1/27/2022

Sea Watch

419.126.v14 GL (1/27/2022)

©2011-2021 Art Form Architecture, Inc., all rights reserved . You may not build this design without purchasing a license, even if you make changes. This design may have geographic restrictions.



603-431-9559

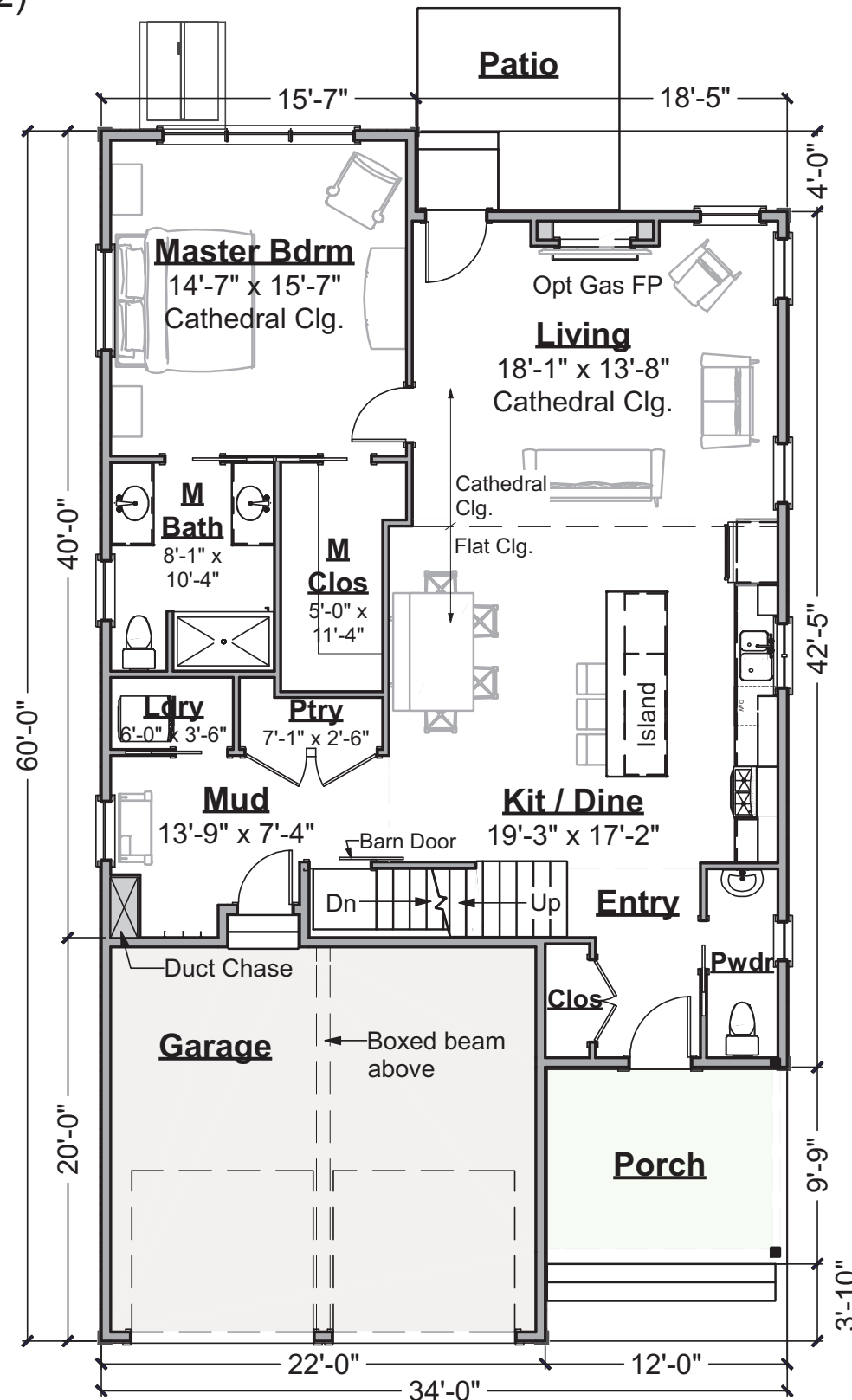

Living Area This Floor: 1370 sq ft
9 ft Ceilings, unless noted otherwise

First Floor Plan
Scale: 3/32" = 1'-0"

1/27/2022

Sea Watch

419.126.v14 GL (1/27/2022)

©2011-2021 Art Form Architecture, Inc., all rights reserved . You may not build this design without purchasing a license, even if you make changes. This design may have geographic restrictions.



603-431-9559

Living Area This Floor: 979 sq ft

8 ft Ceilings, unless noted otherwise

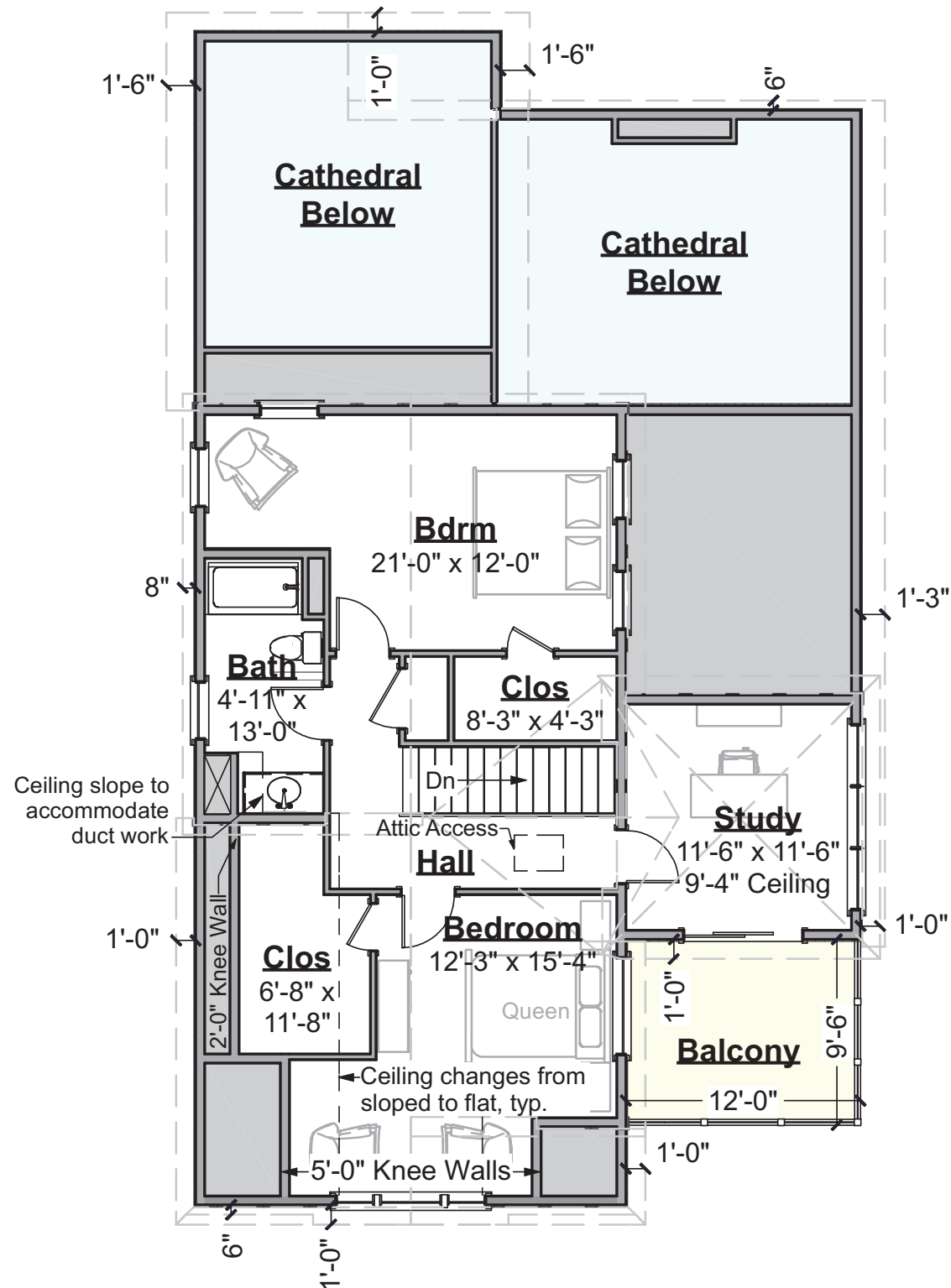

Second Floor Plan
Scale: 3/32" = 1'-0"

1/27/2022

Sea Watch

419.126.v14 GL (1/27/2022)

©2011-2021 Art Form Architecture, Inc., all rights reserved . You may not build this design without purchasing a license, even if you make changes. This design may have geographic restrictions.



603-431-9559

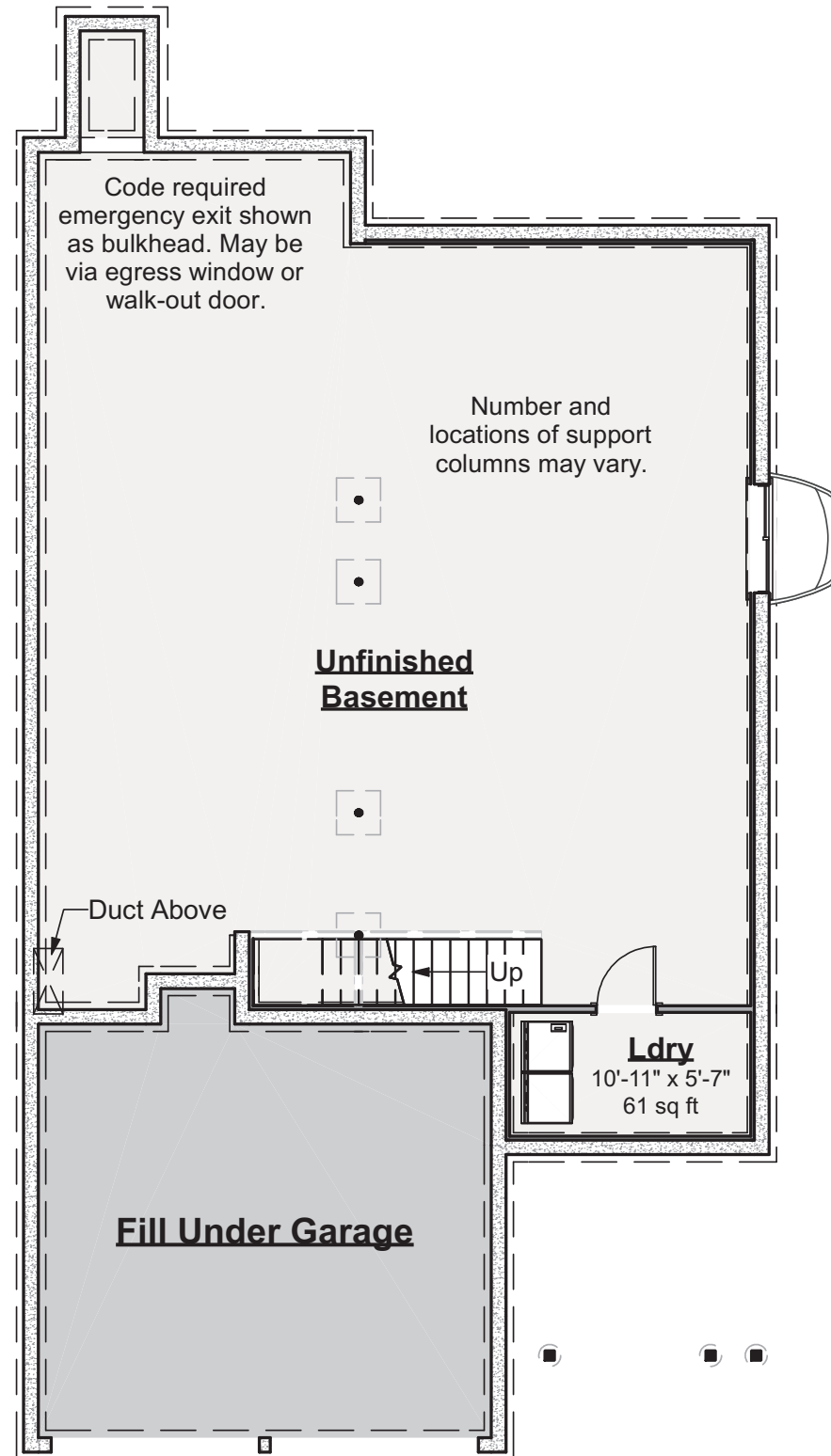

Foundation Plan
Scale: 3/32" = 1'-0"

1/27/2022

Sea Watch

419.126.v14 GL (1/27/2022)

©2011-2021 Art Form Architecture, Inc., all rights reserved . You may not build this design without purchasing a license, even if you make changes. This design may have geographic restrictions.



603-431-9559



Front Elevation

Scale: 1/8" = 1'-0"

1/27/2022

Sea Watch

419.126.v14 GL (1/27/2022)

©2011-2021 Art Form Architecture, Inc., all rights reserved . You may not build this design without purchasing a license, even if you make changes. This design may have geographic restrictions.



603-431-9559



Right Elevation
Scale: 1/8" = 1'-0"

1/27/2022

Sea Watch

419.126.v14 GL (1/27/2022)

©2011-2021 Art Form Architecture, Inc., all rights reserved . You may not build this design without purchasing a license, even if you make changes. This design may have geographic restrictions.



603-431-9559



Rear Elevation

Scale: 1/8" = 1'-0"

1/27/2022

Sea Watch

419.126.v14 GL (1/27/2022)

©2011-2021 Art Form Architecture, Inc., all rights reserved . You may not build this design without purchasing a license, even if you make changes. This design may have geographic restrictions.



603-431-9559



Left Elevation
Scale: 1/8" = 1'-0"

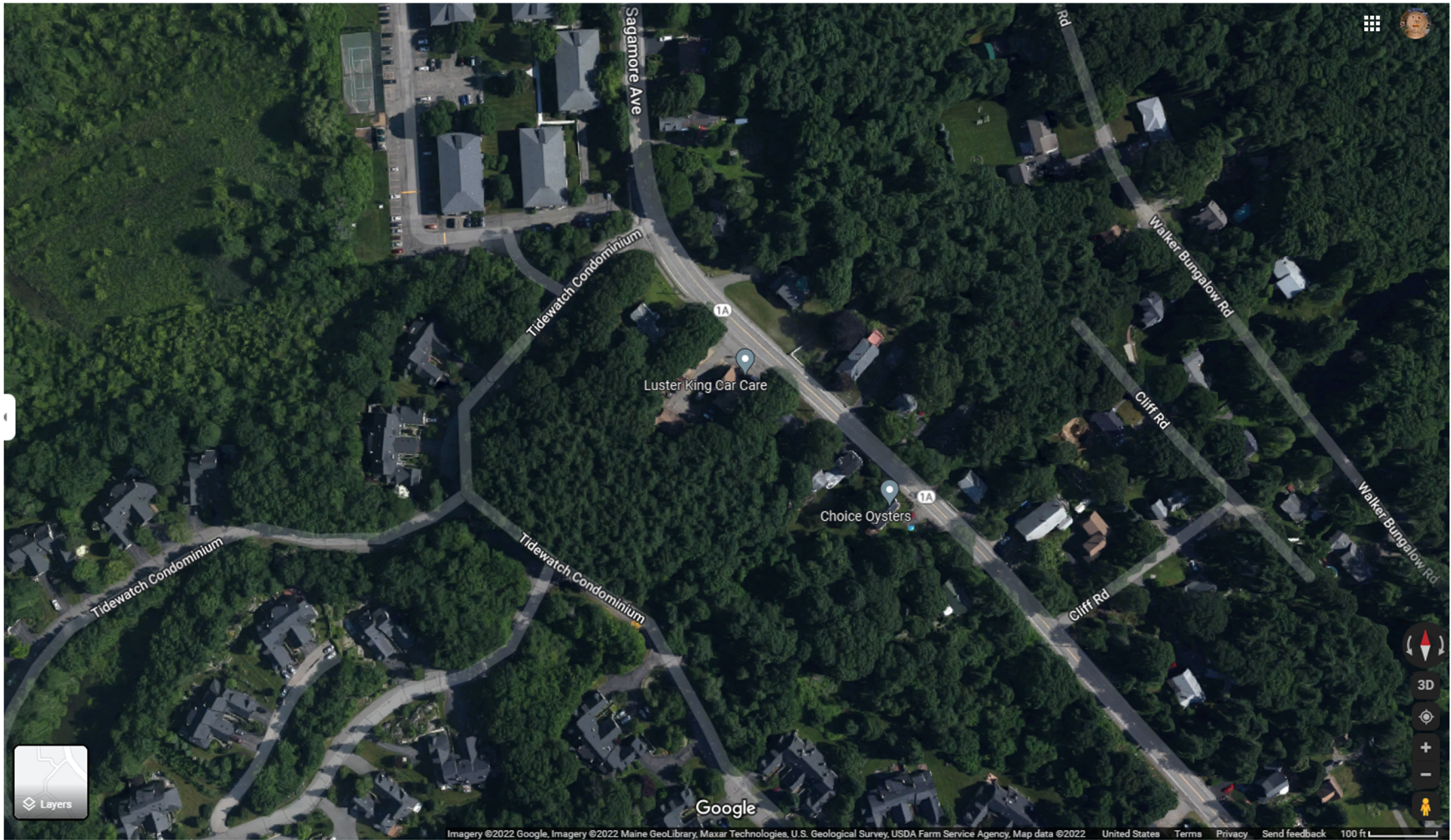

Aerial view of Property



Front View of Property (Sagamore Ave)



Front View of Property



Front View of Property



Side View of Property



View of Service Garage and Shed



Rear View of Property

1/27/2022

Sea Watch

419.126.v14 GL (1/27/2022)

©2011-2021 Art Form Architecture, Inc., all rights reserved . You may not build this design without purchasing a license, even if you make changes. This design may have geographic restrictions.



603-431-9559



635 SAGAMORE AVE

Location 635 SAGAMORE AVE

Mblu 0222/ 0019/ 0000/ /

Acct# 35416

Owner 635 SAGAMORE
DEVELOPMENT LLC

PBN

Assessment \$682,800

Appraisal \$682,800

PID 35416

Building Count 2

Current Value

Appraisal			
Valuation Year	Improvements	Land	Total
2020	\$407,600	\$275,200	\$682,800

Assessment			
Valuation Year	Improvements	Land	Total
2020	\$407,600	\$275,200	\$682,800

Owner of Record

Owner 635 SAGAMORE DEVELOPMENT LLC
Co-Owner
Address 3612 LAFAYETTE RD DEPT 4
 PORTSMOUTH, NH 03801

Sale Price \$387,133
Certificate
Book & Page 6332/1158
Sale Date 09/24/2021

Ownership History

Ownership History				
Owner	Sale Price	Certificate	Book & Page	Sale Date
635 SAGAMORE DEVELOPMENT LLC	\$387,133		6332/1158	09/24/2021
HINES FAMILY REVO TRUST	\$0		4885/1538	02/11/2008

Building Information

Building 1 : Section 1

Year Built: 1950
Living Area: 4,477

Replacement Cost: \$513,721
Building Percent Good: 54
Replacement Cost
Less Depreciation: \$277,400

Building Attributes	
Field	Description
Style:	Retail/Apartment
Model	Commercial
Grade	C
Stories:	2
Occupancy	3.00
Residential Units	
Exterior Wall 1	Vinyl Siding
Exterior Wall 2	Pre-Fab Wood
Roof Structure	Gable/Hip
Roof Cover	Asph/F Gls/Cmp
Interior Wall 1	Drywall/Sheet
Interior Wall 2	
Interior Floor 1	Inlaid Sht Gds
Interior Floor 2	Carpet
Heating Fuel	Oil
Heating Type	Hot Water
AC Type	Unit/AC
Bldg Use	PRI COMM
Total Rooms	
Total Bedrms	
Total Baths	
Kitchen Grd	
Heat/AC	NONE
Frame Type	WOOD FRAME
Baths/Plumbing	AVERAGE
Ceiling/Wall	CEIL & WALLS
Rooms/Prtns	AVERAGE
Wall Height	10.00
% Comn Wall	
1st Floor Use:	
Class	

Building Photo

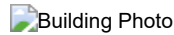

(http://images.vgsi.com/photos2/PortsmouthNHPhotos///0033/DSC01732_;

Building Layout

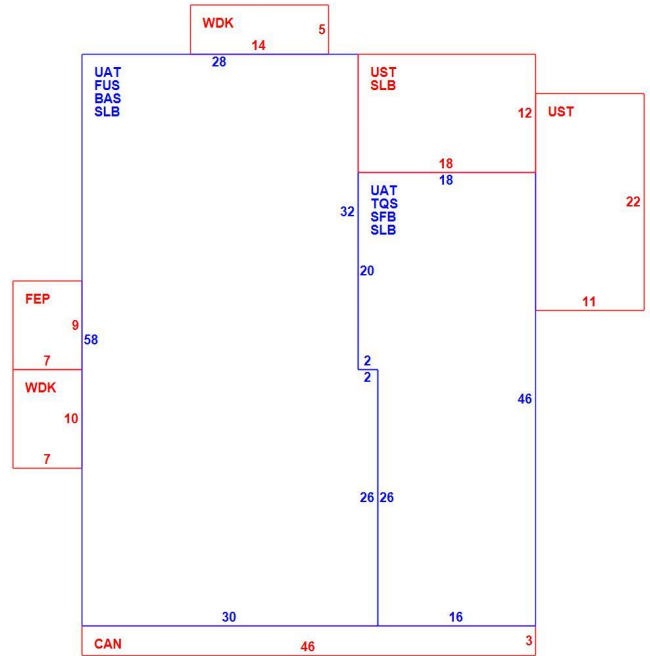

(ParcelSketch.ashx?pid=35416&bid=35416)

Building Sub-Areas (sq ft)			Legend
Code	Description	Gross Area	Living Area
BAS	First Floor	1,676	1,676
FUS	Upper Story, Finished	1,676	1,676
TQS	Three Quarter Story	776	582
SFB	Base, Semi-Finished	776	543
CAN	Canopy	138	0
FEP	Porch, Enclosed	63	0
SLB	Slab	2,668	0
UAT	Attic	2,452	0
UST	Utility, Storage, Unfinished	458	0
WDK	Deck, Wood	140	0
		10,823	4,477

Building 2 : Section 1

Year Built: 2000
Living Area: 1,650
Replacement Cost: \$153,450

Building Percent Good: 84
 Replacement Cost
 Less Depreciation: \$128,900

Building Attributes : Bldg 2 of 2	
Field	Description
Style:	Service Shop
Model	Commercial
Grade	C
Stories:	1
Occupancy	1.00
Residential Units	
Exterior Wall 1	Vinyl Siding
Exterior Wall 2	
Roof Structure	Gable/Hip
Roof Cover	Asph/F Gls/Cmp
Interior Wall 1	Drywall/Sheet
Interior Wall 2	
Interior Floor 1	Concr-Finished
Interior Floor 2	Carpet
Heating Fuel	Oil
Heating Type	Hot Water
AC Type	None
Bldg Use	AUTO S S&S
Total Rooms	
Total Bedrms	
Total Baths	
Kitchen Grd	
Heat/AC	NONE
Frame Type	WOOD FRAME
Baths/Plumbing	AVERAGE
Ceiling/Wall	CEIL & WALLS
Rooms/Prtns	AVERAGE
Wall Height	12.00
% Comn Wall	
1st Floor Use:	
Class	

Building Photo

 Building Photo
 (http://images.vgsi.com/photos2/PortsmouthNHPhotos///0033/DSC01731_;

Building Layout

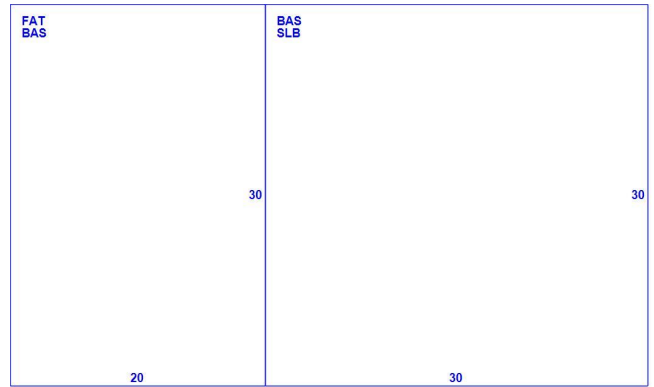

(ParcelSketch.ashx?pid=35416&bid=40140)

Building Sub-Areas (sq ft)			<u>Legend</u>
Code	Description	Gross Area	Living Area
BAS	First Floor	1,500	1,500
FAT	Attic	600	150
SLB	Slab	900	0
		3,000	1,650

Extra Features

Extra Features

Legend

Land

Land Use

Use Code 0310
Description PRI COMM
Zone SRA
Neighborhood 306
Alt Land Appr No
Category

Land Line Valuation

Size (Acres) 1.93
Frontage
Depth
Assessed Value \$275,200
Appraised Value \$275,200

Outbuildings

Outbuildings						<u>Legend</u>
Code	Description	Sub Code	Sub Description	Size	Value	Bldg #
PAV1	PAVING-ASPHALT			1344.00 S.F.	\$1,200	1
SHD1	SHED FRAME			96.00 S.F.	\$100	1

Valuation History

Appraisal			
Valuation Year	Improvements	Land	Total
2020	\$418,400	\$275,200	\$693,600
2019	\$418,400	\$275,200	\$693,600
2018	\$391,100	\$254,800	\$645,900

Assessment			
Valuation Year	Improvements	Land	Total
2020	\$418,400	\$275,200	\$693,600
2019	\$418,400	\$275,200	\$693,600
2018	\$391,100	\$254,800	\$645,900

635 Sagamore Avenue

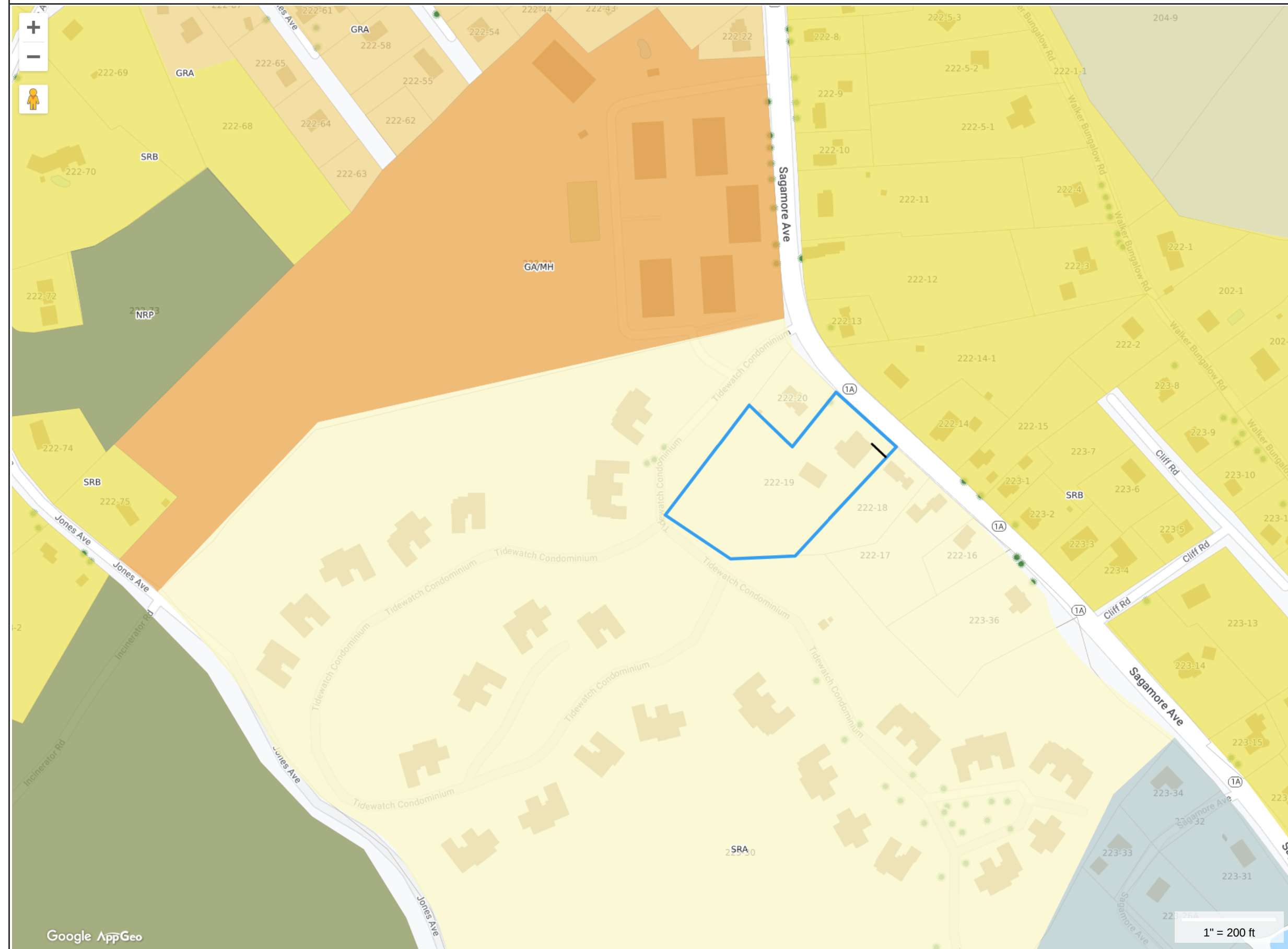

Property Information

Property ID	0222-0019-0000
Location	635 SAGAMORE AVE
Owner	635 SAGAMORE DEVELOPMENT LLC



**MAP FOR REFERENCE ONLY
NOT A LEGAL DOCUMENT**

City of Portsmouth, NH makes no claims and no warranties, expressed or implied, concerning the validity or accuracy of the GIS data presented on this map.

Geometry updated 3/9/2022
Data updated 3/9/2022

Print map scale is approximate. Critical layout or measurement activities should not be done using this resource.

EXHIBIT E

WHITE APPRAISAL

REAL ESTATE APPRAISING & CONSULTING

Brian W. White, MAI, SRA



October 28, 2022

EXHIBIT F

Timothy Phoenix, Esquire
Hoefle, Phoenix, Gormley & Roberts, PLLC
127 Parrott Avenue
P.O. Box 4480
Portsmouth, NH 03802-4480

RE: The Variance application for a four-unit freestanding single-family development to be located on 635 Sagamore Avenue in Portsmouth, New Hampshire.

Attorney Phoenix:

At your request, I have been asked to investigate the impact on the value of the abutting properties for the proposed four-unit freestanding single-family development to be located on 635 Sagamore Avenue (Map 222, Lot 19) and to prepare an analysis and opinion on the matter. I have reviewed the Portsmouth Zoning Ordinance that addresses the standards for the requested variance. To prepare this letter, I have completed research on the proposed subject property, the neighborhood and the Portsmouth marketplace. The following letter summarizes my analysis, findings and conclusions:

1. The Existing Development:

The subject property is a 1,947-acre parcel of land located on the southern side of Sagamore Avenue in the Single Residence A (SRA) zone. The subject property is currently improved with an older 4,477 square-foot, mixed-use, building that contains a first-floor commercial garage unit and two upper-level apartments and an older 1,650 square-foot, one-story, two-bay, garage building. The improvements were constructed in 1950 and 2000 and they appear to be in below average overall condition for the Sagamore Avenue area. The front portion of the parcel has paved drive and parking areas. The existing development utilizes approximately the front third of the parcel with the central and rear areas of the parcel being treed with a large number of evergreens and some deciduous trees. The terrain for the parcel has a natural downward slope in a northeast to southwest direction. The parcel is serviced with municipal water, electricity, telephone, natural gas, cable and internet. The central and rear portions of the parcel have several rock outcroppings. There are no wetland areas located on the parcel.

2. The Proposed Development:

The two older wood-frame buildings will be razed and a new paved drive will be installed off of Sagamore Avenue in the northeastern portion of the subject's parcel. This paved drive will extend into the central portion of the parcel providing access to four freestanding single-family residences. There will be a vehicle turn-around located at the end of the drive area.

Each of the single-family residences will have a front paved driveway that will provide access to a two-car garage. The residences will each contain two levels of finished living area with the three centrally located residences having a walk-out basement area given the natural sloping terrain. The units will have quality interior and exterior finishes that are commensurate with other similar new construction residences located in Portsmouth. Based on the proposed building plans, the proposed single-family residences will contain from 2,111 square feet to 2,349 square feet (2,230 SF average). The single-family homes will be surrounded by landscaped and grassed areas and there will be a rear patio area. There will be plantings located to the rear of the residences providing additional screening from abutting properties. According to Michael Garrepy, Consultant to the ownership of 635 Sagamore Development, LLC, the anticipated retail prices for the four proposed single-family residences will range from approximately \$1,000,000 to \$1,200,000.

3. Neighborhood & Abutting Properties:

The subject property is located in a large Single Residence A (SRA) zone and the land located directly across from the subject property on Sagamore Avenue is zoned Single Residence B (SRB). Both of these zones allow for single-family dwellings with a few other uses allowed as a conditional use or a special exception. Directly abutting the subject property on Sagamore Avenue are two single-family residences (Circa 1940 & 1964) that are small two-bedroom residences with a one-car garage. There are three single-family residences (Circa 1890, 1940 & 1985) located across Sagamore Avenue from the subject property. These residences range in size from a 1,248 square foot one-bedroom residence to a 2,861 square foot three-bedroom residence. In general, these abutting and nearby single-family residences are in average to above average overall condition. None of these nearby single-family residences have sold within the past several years. The average assessment for these five nearby single-family residences is approximately \$460,000. The Tidewatch Condominium development is a 116-unit single-family condominium development located at 579 Sagamore Avenue. The entry road for this development abuts the rear portion of the subject property to the south of the subject property. These townhouse style units were constructed beginning in the late 1980s and they are generally in above average to good overall condition. Over the past two years, units in this development have sold from \$650,000 to \$1,240,000 with an average sale price of approximately \$815,000.

4. Factors that impact Value and the Application to the Subject Property:

For the subject property, there are three potential factors that could directly impact the market value of the abutting properties. These factors are noise, view and use.

Noise:

It was previously noted that the proposed subject property will contain a single-entry drive and four freestanding single-family residences. Two of the subject's proposed residences will be located in the front third of the parcel along Sagamore Avenue while three of the proposed residences will be located in the center portion of the parcel. The rear third of the parcel will remain undeveloped and treed. At the present time, the subject's improvements contain a mixture of apartment units and two commercial units each containing garage space along with supporting drive and parking areas for business related vehicles. At the present time, the noises emitted from the subject property are from residential tenants entering and

exiting their apartment units and from vehicular traffic entering and exiting from the parking area. There are also likely noises from the car doors opening and closing. In addition, there are noises from the commercial garage work being completed along with the garage doors opening and closing. The subject's proposed residential development will contain a single paved drive (ingress and egress) that will extend into the center portion of the parcel. It is noted that given the sloping terrain of the parcel, the developed areas of the parcel will be located approximately 20 to 30 feet higher than the Tidewatch Condominium access road which is located to the rear of the subject's parcel. The vehicle noise from the proposed development will likely be somewhat similar to that currently emitted by the existing development. One difference is that the subject's proposed development will have a road extending into the center portion of the parcel and another difference is that each residential unit will have a two-car garage. The longer entry drive will bring vehicles into the center portion of the parcel which will likely slightly increase vehicle noise. The fact that each residential unit has a two-car garage will likely decrease the noise from opening and closing of car doors as they will largely be contained in garage areas as opposed to the current situation of many vehicles being parked outside. These differences will likely be off-setting. There will obviously be additional noise from the use and maintenance of the four single-family residences. However, these noises are no different than what is currently heard from the abutting and surrounding residences. The typical buyer of a property located in close proximity to the subject property would be aware of this potential. Considering all of these factors, it is reasonable to conclude that the proposed four-unit single-family development of the subject property will be configured in such a manner that there would not be an increase in non-residential noises that would be over and above that of any other permitted uses in the "SRA" and "SRB" zones.

View:

At the present time, the subject's combined mixed-use (commercial garage, apartments and exterior parking areas) development is very visible from the road traffic and the abutting residences located along Sagamore Avenue. It is visible in the distance with a heavy wooded screen from the Tidewatch Condominium access road and from the front areas of several townhouse-style condominium units in the development. From the front and central portions of the subject property, the two abutting older single-family residences area visible along with the three residences located across Sagamore Avenue to the north, east and west. To the south, the access road for the Tidewatch Condominium development is visible in the distance with a heavy wooded screen.

The existing mixed-use development of the subject property is an average condition development that some would consider to be an eyesore for the mostly above average to good condition residential neighborhood of the subject property. There is no screening of these mixed-use buildings and the supporting drive and parking areas from Sagamore Avenue. The proposed four-unit residential development will have a single paved drive located in the eastern portion of the parcel. The front building will be setback further from Sagamore Avenue than the existing mixed-use building and it will be surrounded by grassed and landscaped areas. A second single-family residence will be located approximately 25' to the rear of the front residence. The proposed subject property will greatly enhance the views from the neighboring single-family residences located along Sagamore Avenue. The subject's two rear detached single-family residences will be located in the central portion of the parcel which is currently undeveloped woods. These two detached residences will be

visible from the rear yard areas of the two abutting single-family residences and they will be visible in the distance from the front parking and building areas of several townhouse-style condominium units located in the Tidewatch Condominium development. The front portion of the development that abuts 607 Sagamore Avenue will contain a new 6' vinyl fence and new screening that will include Giant Arborvitae and Greenspire Littleleaf Linden trees. The western and southern developed areas that face the Tidewatch condominium access road will have additional screening that will include Canadian Hemlock, Eastern White Pine, Norway Spruce, Chanticleer Callery Pear, Sweetgum and Cherry trees. This fencing along with the proposed enhanced screening has been designed to provide additional screening from neighboring properties. Additionally, the rear portion of the property will remain undeveloped leaving the natural wooded screen in place. The views of several nearby residential properties will change but not to the extent that any negative impact will result. It could be argued that the views of the neighboring properties will be enhanced by replacing the older average condition mixed-use development and asphalt drive and parking lot with new construction freestanding single-family residences that will be in very good condition with retail values that will exceed that of all the neighboring properties.

Use:

The subject property is proposed for use as a four-unit freestanding single-family development. In the surrounding neighborhood, the Sagamore Avenue area is developed with a variety of residential uses (single-family, residential condominiums and apartments) and several scattered commercial and mixed-use developments. The interior streets located off of Sagamore Avenue are largely developed with residential uses. The proposed single-family development of the subject property will be in-line with that of the surrounding uses. In the Variance application, it is pointed out that the abutting Tidewatch Condominium development to the south and west is also located in the SRA zone. This townhouse-style condominium development contains 116 units located on 53.59 acres of land. This translates into a density of 2.16-units per acre. Sagamore Court Condominiums to the north of the subject property on Sagamore Avenue is a 144-unit development on 15.01-acres (9.59-units/acre). The subject's proposed 4 units will be located on a 1.947-acre parcel (2.05-units/acre). Considering the density of these abutting and nearby residential condominium developments, the subject's proposed density is reasonably in-line with the existing density in the immediate area. It can reasonably be concluded that the proposed use of the subject property as a four-unit freestanding single-family development is a use that will be compatible with the surrounding neighborhood.

5. *Specific Standards – Variances:*

The owners are requesting a Variance from the following – Portsmouth Zoning Ordinance – 10.513 - Permitting one freestanding dwelling per lot, where four freestanding single-family units are proposed) and Portsmouth Zoning Ordinance – Table of Dimensional Standards – permitting one dwelling unit per acre, where four dwelling units on a 1.947-acre parcel is proposed (2.05 dwelling units per acre). As Rosann Maurice-Lentz was unavailable for comment, I spoke with Scott Scott, Tax Assessor II for the City of Portsmouth. I wanted to get his opinion on the subject's proposed freestanding single-family development and that of several other recently proposed or recently constructed multi-unit residential developments located in the Sagamore Avenue area. He stated that he is very familiar with the Sagamore Avenue area. He indicated that the fact that the subject's units are freestanding units, and not

multi-unit buildings, makes them more attractive overall. Additionally, he stated that he doesn't "think that this development would bring down the surrounding values and it would more likely bring them up". I have attempted to gather market sales data from the Portsmouth area that would speak to the change in permitted units where freestanding single-family homes were permitted and possible value changes. In the greater Portsmouth area, there is no exactly similar property from which to extract paired-sales. Therefore, only general observations can be made based on my experience in the marketplace. Over the past several years in the greater Sagamore Avenue area of Portsmouth, several new multi-unit residential developments have been constructed or are currently proposed. In general, the addition of these new residential developments has resulted in upgrading the overall condition of the neighborhood and therefore enhancing the overall desirability of the area.

It is my opinion that granting the requested variance for the subject property to be improved with a four-unit freestanding single-family development would not result in the diminution in value of the abutting property values in the immediate vicinity of the subject property and the proposed subject property would not change the characteristics of the neighborhood. In fact, the addition of the proposed subject property will add several attractive and modern single-family residences to the neighborhood that very well could enhance the value of the surrounding properties as it will add a new residential units to a location that is currently under improved for the area.

Respectively submitted,



Brian W. White, MAI, SRA NHC#-52

ADDENDA

TABLE OF CONTENTS

Transmittal Letter	1-5
Addenda	6
Table of Contents	7
Photographs	8-17
Portsmouth Assessor's Card	18-21
Deed	22-23
Aerial View	24
Assessor's Map	25
Zoning Map	26-27
Flood Map	28
Zoning Information	29-48
Variance Application	49-82
Site Buffer Plan	83
Certificate	84
Qualifications of the Appraiser	85-87

PHOTOGRAPHS OF THE SUBJECT PROPERTY



Street Scene - Front of the Subject Property
Looking Southeast on Sagamore Avenue - (5/22)



Street Scene - Front of the Subject Property
Looking Southeast on Sagamore Avenue - (5/22)

PHOTOGRAPHS OF THE SUBJECT PROPERTY



Street Scene - Rear of the Subject Property
Looking Southeast on Tidewatch Condominium Access Road - (2/22)



Street Scene - Rear of the Subject Property
Looking Northwest on Tidewatch Condominium Access Road - (5/22)

PHOTOGRAPHS OF THE SUBJECT PROPERTY



Subject Property – Front of the Property
Looking Southwest from across Sagamore Avenue – (5/22)



Subject Property – Front of the Property and the Front Mixed-use Building
Looking Southeast from High Street – (5/22)

PHOTOGRAPHS OF THE SUBJECT PROPERTY



Subject Property – Rear of the Front Mixed-use Building
Looking East from Rear Paved Area – (5/22)



Subject Property – Front of the Rear Garage Building
Looking Southwest from Paved Drive Area – (5/22)

PHOTOGRAPHS OF THE SUBJECT PROPERTY



Subject Property – Rear of the Rear Garage Building
Looking Northeast from Rear Wooded Area – (5/22)



View of the Rear of the Subject Property from Tidewatch Condominium Access Road
Looking Northeast - (5/22)

PHOTOGRAPHS OF THE SUBJECT/SURROUNDING PROPERTIES



View of the Rear of the Subject Property from Tidewatch Condominium Access Road
Looking East - (5/22)



View of Typical Tidewatch Condominium Building
Looking South from Access Road - (5/22)

PHOTOGRAPHS OF THE SUBJECT/SURROUNDING PROPERTIES



View of Tidewatch Access Road from rear of Proposed Residences
Looking South - (5/22)



View of Tidewatch Access Road from rear of Proposed Residences
Looking Southwest - (5/22)

PHOTOGRAPHS OF THE SURROUNDING PROPERTIES



View of Abutting Residence at 607 Sagamore Road
Looking Southwest from Front of the Subject Property - (5/22)



View of Abutting Residence at 695 Sagamore Road
Looking Southeast from Sagamore Road to the Front of the Subject Property - (5/22)

PHOTOGRAPHS OF THE SURROUNDING PROPERTIES



View of Residence located across Sagamore Road - 594 Sagamore Road
Looking North from Sagamore Road to the Front of the Subject Property - (5/22)



View of Residence located across Sagamore Road - 650 Sagamore Road
Looking Northeast from Sagamore Road to the Front of the Subject Property - (5/22)

PHOTOGRAPHS OF THE SURROUNDING PROPERTIES



View of Residence located across Sagamore Road - 692 Sagamore Road
Looking East from Sagamore Road to the Front of the Subject Property - (5/22)

CURRENT OWNER		TOPD	UTILITIES	STRT / ROAD	LOCATION	CURRENT ASSESSMENT													
635 SAGAMORE DEVELOPMENT LL		1 Level	1 Public Sewer	1 Paved	2 Suburban	Description	Code	Assessed	Assessed	2229									
3612 LAFAYETTE RD DEPT 4		SUPPLEMENTAL DATA				COMMERC.	0310	406,300	406,300	PORTSMOUTH, NH									
PORTSMOUTH NH 03801		Air Pct ID 0222-0019-0000-0000 OLDACTN 9000 PHOTO WARD PREC. 1/2 HSE GIS ID 35416				COM LAND	0310	275,200	275,200										
		CONDO C INLAW W LOT SPLIT 2015 Reval V JM Ex/Dr Appli Assoc Plat#				COMMERC.	0310	1,300	1,300										
						Total		682,900	682,900										
RECORD OF OWNERSHIP		BK-VOL/PAGE	SALE DATE	QU	VI	SALE PRICE	VC	PREVIOUS ASSESSMENTS HISTORY											
635 SAGAMORE DEVELOPMENT LLC HINES FAMILY REVO TRUST		8332 4885	1158 1536	09-24-2021 02-11-2008	U U	387,130 0	44	Year	Code	Assessed	Year	Code	Assessed	Year	Code	Assessed			
								2020	0310	416,800	2019	0310	294,600	2018	0310	294,600			
									0310	275,200		0310	275,200		0310	275,200			
									0310	1,800		0310	1,800		0310	1,800			
									0310	132,000		0310	132,000		0310	132,000			
								Total		693,000	Total		693,000	Total		693,000			
EXEMPTIONS		OTHER ASSESSMENTS		Risk signature acknowledges avail by a Data Collector or Assessor															
Year	Code	Description	Amount	Code	Description	Number	Amount	Comm Int											
		Total				0.00													
ASSESSING NEIGHBORHOOD		APPRaised VALUE SUMMARY																	
Nbrhd	Nbrhd Name	STREET INDEX NAME		Trading									Appraised Bldg. Value (Card)	406,300					
905													Appraised Xf (B) Value (Bldg)	0					
													Appraised Ob (B) Value (Bldg)	1,300					
													Appraised Land Value (Bldg)	275,200					
													Special Land Value	0					
													Total Appraised Parcel Value	682,800					
													Valuation Method	C					
													Total Appraised Parcel Value	682,900					
BUILDING PERMIT RECORD		VISIT / CHANGE HISTORY																	
Permit ID	Issue Date	Type	Description	Amount	Insp Date	% Comp	Date Comp	Comments	Date	ID	Type	Is	Cd	Purpose/Route					
									05-22-2017	ST			ER	Exterior Review					
									09-16-2016	VS			DE	Date Entry					
									03-13-2015	ST			ER	Exterior Review					
									08-25-2013	JM			00	Measure+Listed INACTIVE					
									02-12-2010	ST			ER	Exterior Review					
									11-10-2009	RK	02		01	Measure+Visit INACTIVE					
									07-24-2006	JR		0	3	Conv INACTIVE					
LAND USE VALUATION SECTION																			
B	Use Code	Description	Zone	Frontage	Depth	Land Units	Unit Price	Size Adj	Site	Cond.	ST	SJ	Notes- Adj	Special Pricing	Adj Unit P	Land Value			
1	0310	PRI COMM	SRA			84.07	34.8	1.0000	1	0.65	306	0.230	-49% SHAPE, SIZE		1,0000	3.27	275,350		
Total Card Land Units						2	AC	Parcel Total Land Area						2	Total Land Value				275,200

CONSTRUCTION DETAIL			CONSTRUCTION DETAIL (CONTINUED)		
Element	Code	Description	Element	Code	Description
Style	80	Retail/Apartment			
Model	94	Commercial			
Grade	C				
Stories	2				
Occupancy	3.00				
Residential Unit					
Exterior Wall 1	25	Vinyl Siding			
Exterior Wall 2	13	Pre-Pan Wood			
Roof Structure	03	Gable/Hip			
Roof Cover	03	Asph/F Gls/Cmp			
Interior Wall 1	06	Drywall/Sheet			
Interior Wall 2					
Interior Floor 1	06	Inbid Sht Gds			
Interior Floor 2	14	Carpet			
Heating Fuel	02	Oil			
Heating Type	05	Hot Water			
AC Type	04	UnitVAC			
Slip Use	0310	PR1 COMM			
Total Rooms					
Total Bedrooms					
Total Baths					
Kitchen Grd					
Heat/AC	00	NONE			
Frame Type	02	WOOD FRAME			
Baths/Plumbing	02	AVERAGE			
Ceiling/Wall	06	CEL & WALLS			
Rooms/Prns	02	AVERAGE			
Wall Height	10.00				
% Conn Wall					
1st Floor Use					
Class					

MIXED USE		
Code	Description	Percentage
0310	PR1 COMM	100
		0
		0

COST/MARKET VALUATION	
Code	Description
	Act. State Rate
	103.95
	RCN
	513,721
	Year Built
	1950
	Effective Year Built
	1993
	Depreciation Code
	A
	Remodel Rating
	Year Remodeled
	Depreciation %
	36
	Functional Obsolet
	10
	External Obsolet
	1
	Condition
	Condition %
	(Percent) Good
	56
	RCNLD
	277,400
	Dep % Cvr
	Dep Cvr Comment
	Misc Imp Cvr
	Misc Imp Cvr Comment
	Cost to Cure Cvr
	Cost to Cure Cvr Comment

OB - OUTBUILDING & YARD ITEMS / XF - BUILDING EXTRA FEATURES(S)										
Code	Description	Unit	Qty	Unit Price	Yr Bld	Cond	% Cg	Gr	Gr Adj	Appx. Value
PW1	PAVING-ASPHALT	L	1,344	1.75	1965	3	50	C	1.00	1,200
SHD1	SHED FRAME	L	96	13.00	1900	P	10	D	0.90	100

BUILDING SUB-AREA SUMMARY SECTION						
Code	Description	Living Area	Floor Area	EA Area	Unit Cost	Unadjusted Value
BAS	First Floor	1,676	1,676	1,676	103.95	174,220
CAN	Canopy	0	138	28	21.09	2,911
FIBP	Porch, Enclosed	0	63	41	67.85	4,202
FUS	Upper Story, Finished	1,676	1,676	1,676	103.95	174,220
SFB	Base, Semi-Finished	543	776	543	72.74	56,445
SLS	Slab	0	2,656	0	0.00	0
TQS	Three Quarter Story	582	776	582	77.90	65,499
UAT	Attic	0	2,452	245	10.39	25,408
UST	Utility, Storage, Unfinished	0	458	137	31.09	14,241
WDK	Deck, Wood	0	140	14	10.40	1,456
13 Gross Liv / Lease Area		4,477	10,823	4,342		513,721

Property Location: 635 SAGAMORE AVE	Map ID: 0222/0219/0000/		Blg Name: Sec # 1 of 1		Card # 2 of 2		State Use: 0310														
Vision ID: 35416	Account #: 35416		Blg #: 2				Print Date: 11/23/2021 9:11:34 A														
CURRENT OWNER			UTILITIES		STRT / ROAD		LOCATION		CURRENT ASSESSMENT			2229	PORTSMOUTH, NH	VISION							
635 SAGAMORE DEVELOPMENT LL			1 Level 1 Public Sewer		1 Paved		2 Suburban		Description	Code	Assessed				Assessed						
3612 LAFAYETTE RD DEPT 4									COMMER.	0310	405,300	405,300									
PORTSMOUTH NH 03801									COM LAND	0310	275,200	275,200									
									COMMER.	0310	1,300	1,300									
SUPPLEMENTAL DATA																					
All Pcd ID 0222-0019-0000-0000			CONDO C		INLAW Y		LOT SPLIT		2015 Reval V		JM										
PHOTO			WARD		PREC.		1/2 HSE		GIS ID 35416		Assoc Pcd#										
RECORD OF OWNERSHIP												PREVIOUS ASSESSMENTS HISTORY									
635 SAGAMORE DEVELOPMENT LLC												Year	Code	Assessed	Year	Code	Assessed	Year	Code	Assessed	
HINES FAMILY REVO TRUST												44	2020	0310	416,600	2019	0310	284,600	2018	0310	284,600
8332 1155 09-24-2021 U I I 987,133																					
4885 1636 02-11-2008 U I I 0																					
												0310	275,200	0310	275,200	0310	275,200	0310	275,200		
												0310	1,800	0310	1,800	0310	1,800	0310	1,800		
												0310	132,000	0310	132,000	0310	132,000	0310	132,000		
												Total	682,800	Total	682,800	Total	682,800	Total	682,800		
EXEMPTIONS						OTHER ASSESSMENTS						This signature acknowledges a visit by a Data Collector or Assessor									
Year	Code	Description	Amount	Code	Description	Number	Amount	Code	Description	Amount	Code	Description	Amount	Code	Description						
			0.00																		
APPRAISED VALUE SUMMARY																					
Appraised Bldg. Value (Card)												405,300									
Appraised Xt (B) Value (Bldg)												0									
Appraised Db (B) Value (Bldg)												1,300									
Appraised Land Value (Bldg)												275,200									
Special Land Value												0									
Total Appraised Parcel Value												682,800									
Valuation Method												C									
Total Appraised Parcel Value												682,800									
BUILDING PERMIT RECORD												VISIT / CHANGE HISTORY									
Permit #	Issue Date	Type	Description	Amount	Insp Date	% Comp	Date Comp	Comments													
								Date	By	Type	Is	Cd	Purpose/Result								
								05-04-2021	JW	02	1	50	Building Permit								
LAND LINE VALUATION SECTION																					
B	Use Code	Description	Zone	Frontage	Depth	Land Units	Unit Price	Size Adj	Site	Cond.	St Use	S.I. Adj.	Notes - Adj	Special Pricing	Adj Unit P	Land Value					
2	0310	PRI COMM				0.000 AC	0	1,000	0	1.00		1,000		0.0000	0	0					
Total Card Land Units						0 AC		Parcel Total Land Area						Total Land Value							
														275,200							

CONSTRUCTION DETAIL			CONSTRUCTION DETAIL (CONTINUED)		
Element	Code	Description	Element	Code	Description
Type	25	Service Shop			
Model	04	Commercial			
Grade	C	C			
Stories	1				
Occupancy	1.00				
Residential Unit					
Exterior Wall 1	25	Vinyl Siding			
Exterior Wall 2					
Roof Structure	03	Gable/Hip			
Roof Cover	03	Asph/F Gbl/Cmp			
Interior Wall 1	05	Drywall/Sheet			
Interior Wall 2					
Interior Floor 1	03	Concr-Finished			
Interior Floor 2	14	Carpet			
Heating Fuel	02	Oil			
Heating Type	05	Hot Water			
AC Type	01	None			
Bldg Use	3310	AUTO S S&S			
Totl Rooms					
Totl Bedrms					
Totl Baths					
Kitchen Grd					
Heat/AC	00	NONE			
Frame Type	02	WOOD FRAME			
Baths/Plumbing	02	AVERAGE			
Ceiling/Wall	06	CEIL & WALLS			
Rooms/Prns	02	AVERAGE			
Wall Height	12.00				
% Core Wall					
1st Floor Use:					
Class					

MIXED USE		
Code	Description	Percentage
0310	PRI COMM	100
		0
		0

COST / MARKET VALUATION		
Adj. Base Rate		
		53,000
RCN		153,450
Year Built	2000	
Effective Year Built	2003	
Depreciation Code	A	
Remodal Rating		
Year Remodeled		
Depreciation %	16	
Functional Obsol		
External Obsol		
Trend Factor	1	
Condition		
Condition %		
Percent Good	84	
RCNLD		120,900
Dep % Ovr		
Dep Ovr Comment		
Mac Imp Ovr		
Mac Imp Ovr Comment		
Cost to Cure Ovr		
Cost to Cure Ovr Comment		

OB - OUTBUILDING & YARD ITEMS(L) / XP - BUILDING EXTRA FEATURES(B)										
Code	Description	Lbs	Units	Unit Price	Nr Bld	Cond	% Gd	Gr	Gr Adj	Appr. Value

BUILDING SUB-AREA SUMMARY SECTION						
Code	Description	Living Area	Floor Area	Eft Area	Unit Cost	Unclappc Value
BAS	First Floor	1,500	1,500	1,500	93.00	139,500
FAT	Atic	150	400	150	23.25	13,950
SLS	Slab	0	500	0	0.00	0
15 Gross Liv / Lease Area		1,650	3,000	1,650		153,450



Return to:

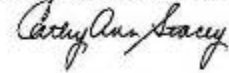

LCHIP	ROA585829	25.00
TRANSFER TAX	RO109828	5,807.00
RECORDING		14.00
SURCHARGE		2.00

WARRANTY DEED

KNOW ALL BY THESE PRESENTS, that I, **WILLIAM A. HINES**, married person, **TRUSTEE OF THE WILLIAM A. HINES FAMILY REVOCABLE TRUST** a/k/a The Hines Family Revocable Trust of 2006, of 635 Sagamore Avenue, Portsmouth, New Hampshire 03801, for consideration paid, hereby grant to **635 SAGAMORE DEVELOPMENT, LLC**, a New Hampshire limited liability company with a mailing address of 3612 Lafayette Road, Dept. 4, Portsmouth, New Hampshire 03801 with **WARRANTY COVENANTS**, the following described premises:

A certain tract of land with the buildings thereon, situate on Sagamore Avenue in said Portsmouth, more particularly described as follows:

Beginning at a point on Sagamore Avenue at land now or formerly of Arnold, thence running Westerly by said Arnold land three hundred (300) feet, more or less, to land now or formerly of W.W. and D.M. Johnston; thence turning and running Northwesterly by said Johnston land one hundred and twenty-four (124) feet; thence turning and running Northerly also by said Johnston land one hundred sixty-two (162) feet to land now or formerly of C.W. Walker; thence turning and running Easterly by said Walker land four hundred nineteen (419) feet to Sagamore Avenue; thence turning and running Easterly one hundred forty (140) feet; thence turning and running along said Sagamore Avenue thirty (30) feet to land of one Smith; thence turning and running Westerly one hundred forty (140) feet; thence turning and running Southerly ninety (90) feet; thence turning and running Easterly one hundred forty (140) feet to Sagamore Avenue; the last three bounds being land of Smith; thence turning running Southerly by said Sagamore Avenue one hundred sixty (160) feet to the point of beginning.

EXCEPTING AND RESERVING to the said William A. Hines and his wife Bonnie Hines a life estate in the above-described property permitting them to reside in the existing residential apartment on the property for the remainder of William A. Hines natural life, plus one year unless Bonnie Hines shall have predeceased.

Meaning and intending to convey the same premises conveyed to the Grantor by deed of William A. Hines dated February 11, 2008 and recorded in the Rockingham County Registry of Deeds at Book 4885, Page 1538.

BY SIGNING BELOW, William A. Hines and Bonnie Hines release all homestead rights to the Premises.

TRUSTEE CERTIFICATE

I, William A. Hines, Trustee of the William A. Hines Family Revocable Trust A/K/A The Hines Family Revocable Trust of 2006, hereby covenant that said Trust is duly organized under the laws of the State of New Hampshire; that I am the sole trustee pursuant to said Declaration of Trust; that said Trust is still in full force and effect; that I have the power thereunder to convey as aforesaid; and that, in making this conveyance, I have, in all respects, acted pursuant to the authority vested in and granted to me therein and no purchaser or third party shall be bound to inquire whether the Trustee has said power or are properly exercising said power or to see to the application of any trust assets paid to the Trustee for a conveyance thereof.

Signed this 3rd day of September, 2021.

William A. Hines

William A. Hines, Trustee of the William A. Hines Family Revocable Trust A/K/A The Hines Family Revocable Trust of 2006

Bonnie L. Hines

Bonnie Hines

STATE OF NEW HAMPSHIRE
COUNTY OF ROCKINGHAM

On this, the 3rd day of September, 2021, before me, the undersigned Officer, personally appeared William A. Hines, Trustee of the William A. Hines Family Revocable Trust A/K/A The Hines Family Revocable Trust of 2006, known to me, or satisfactorily proven, to be the person whose name is subscribed to the foregoing instrument, and acknowledged that he executed the same for the purposes set forth therein.

Laura Ramsdell

Justice of the Peace/Notary Public

My commission expires: _____



STATE OF NEW HAMPSHIRE
COUNTY OF ROCKINGHAM

On this, the 3rd day of September, 2021, before me, the undersigned Officer, personally appeared Bonnie Hines, known to me, or satisfactorily proven, to be the person whose name is subscribed to the foregoing instrument, and acknowledged that she executed the same for the purposes set forth therein.

Laura Ramsdell

Justice of the Peace/Notary Public

My commission expires: _____



AERIAL VIEW



MAP FOR REFERENCE ONLY
NOT A LEGAL DOCUMENT

City of Portsmouth, NH makes no claims and no warranties, expressed or implied, concerning the validity or accuracy of the GIS data presented on this map.

Geometry updated 05/20/22
Data updated 05/10/22

Print map scale is approximate.
Critical layout or measurement
activities should not be done using
this resource.

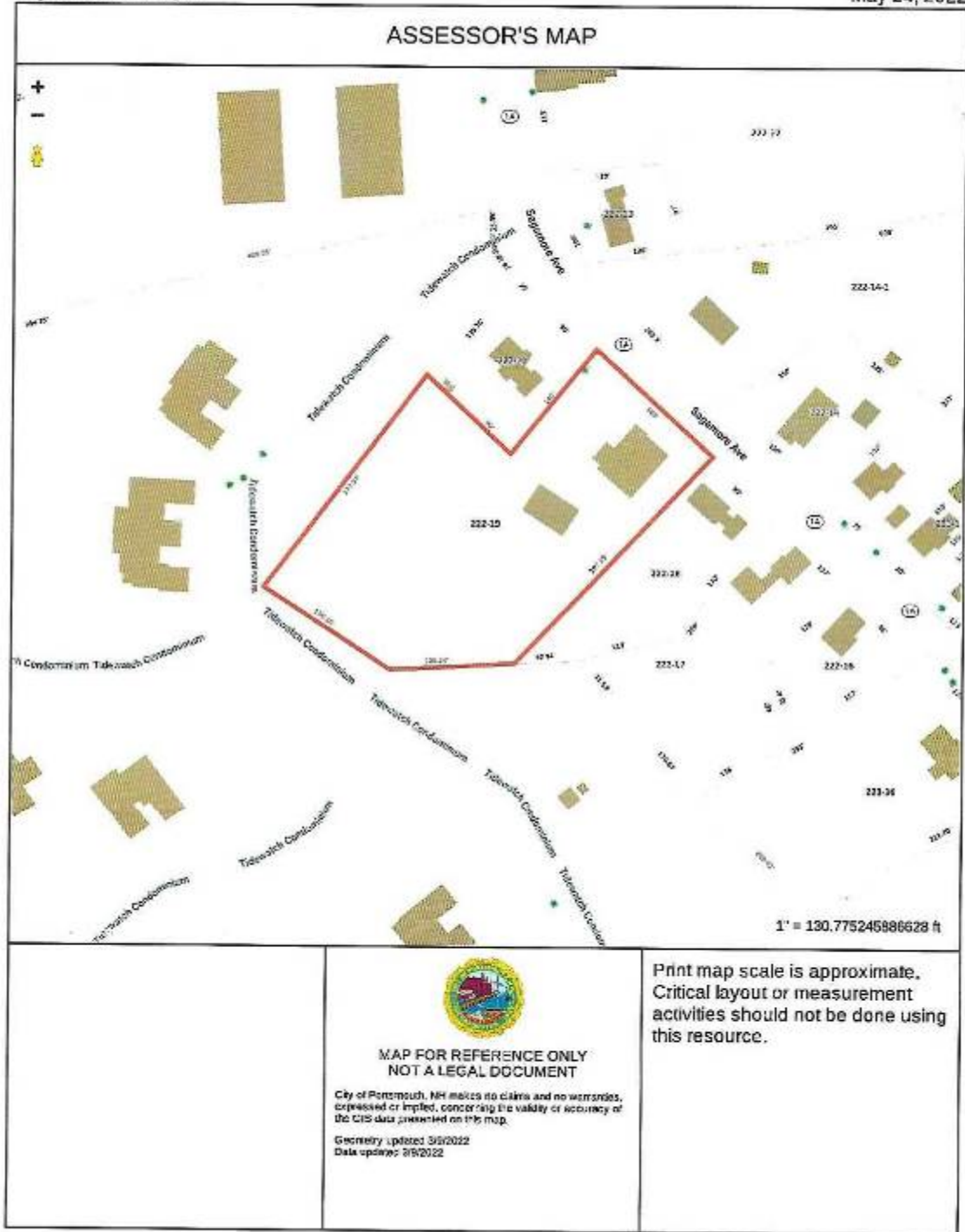

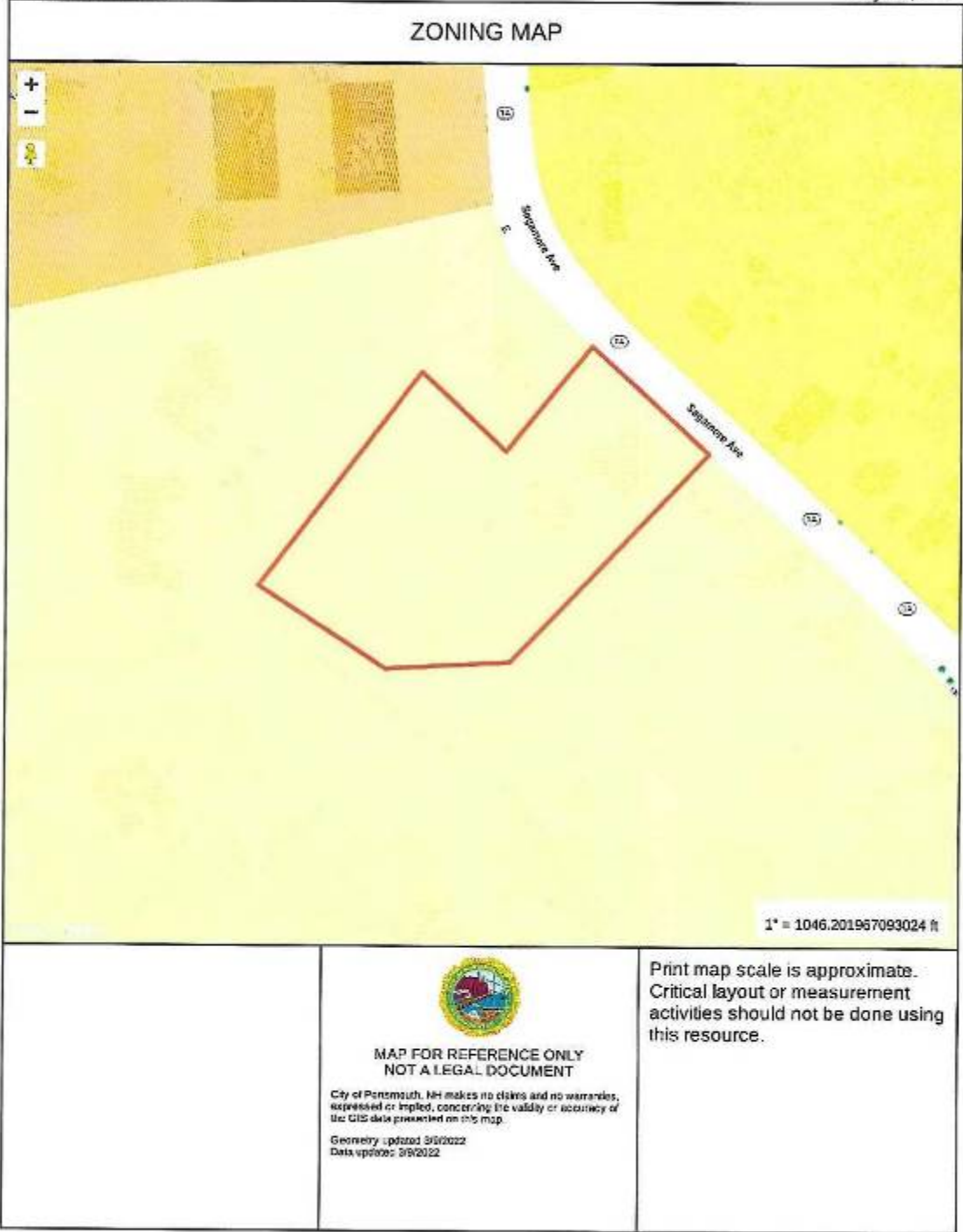

Map Theme Legends

Zoning

Residential Districts	
	R Rural
	SRA Single Residence A
	SRB Single Residence B
	GRA General Residence A
	GRB General Residence B
	GRC General Residence C
	GAWH Garden Apartments/Walkable Home Park
Mixed Residential Districts	
	MRO Mixed Residential Office
	MRB Mixed Residential Business
	C1 Gateway Center
	C2 Gateway Center
Business Districts	
	CB Central Business
	B Business
	WB Woodstock Business
Industrial Districts	
	OR Office Research
	I Industrial
	WI Waterfront Industrial
Airport Districts	
	AIR Airport
	AI Airport Industrial
	PI Pleasant Industrial
	ABC Airport Business Commercial
Conservation Districts	
	M Municipal
	NRP Natural Resource Preservation
Character Districts	
	CD6 Character District 6
	CD4 Character District 4
	CD4B Character District 4-B
	CD4-1 Character District 4-1
	CD4-2 Character District 4-2
Civic District	
	Civic District
Municipal District	
	Municipal District
Overlay Districts	
	DLOD Dipsey Landing Overlay District
	Downtown Overlay District
	Historic District

City of Portsmouth

FLOOD MAP

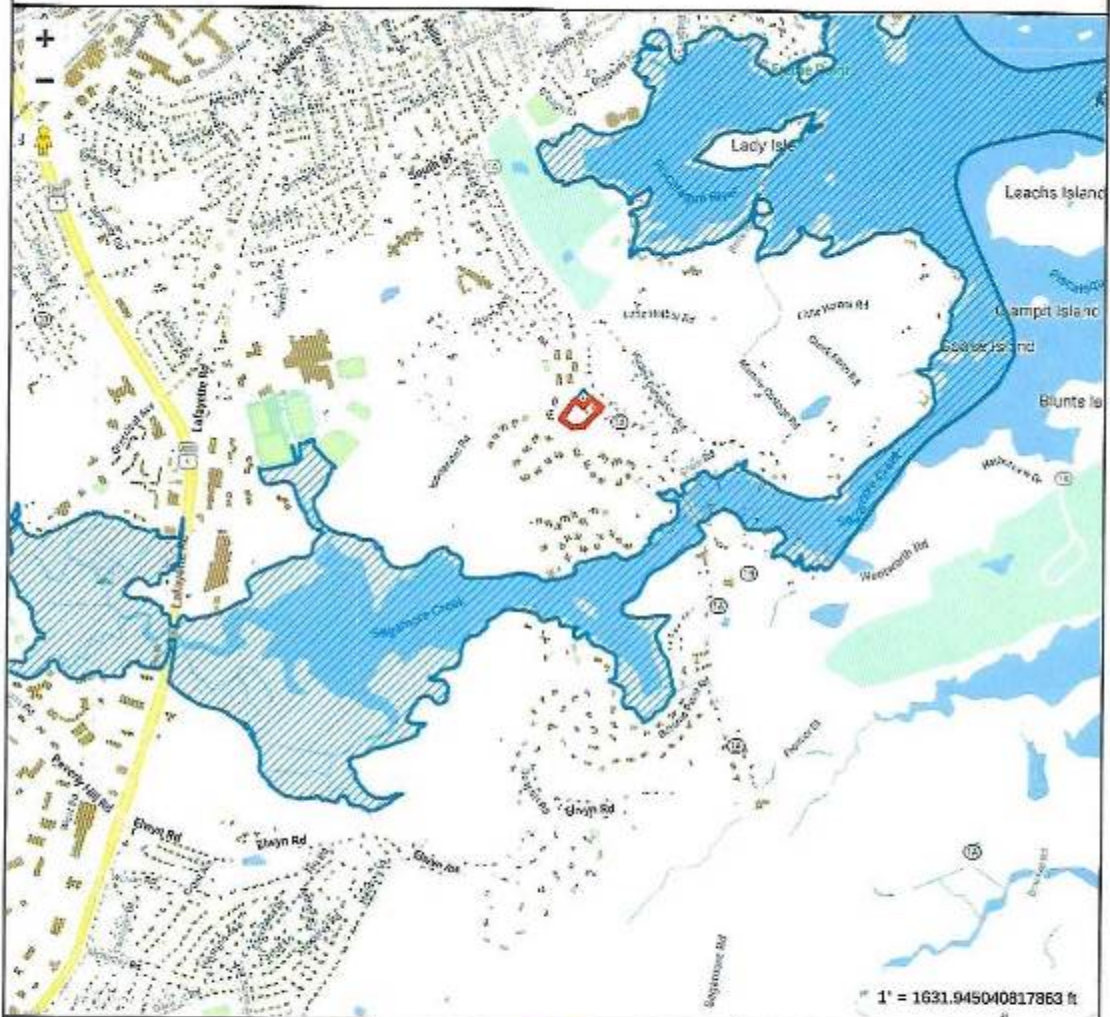

Property Information

Property ID 0222-0020-0000
Location 007 SAGAMORE AVE
Owner PITTEN EVAN W



**MAP FOR REFERENCE ONLY
NOT A LEGAL DOCUMENT**

City of Portsmouth, NH makes no claims and no warranties, expressed or implied, concerning the validity or accuracy of the GIS data presented on this map.

Geometry updated 3/9/2022
Data updated 3/9/2022

Print map scale is approximate.
Critical layout or measurement
activities should not be done using
this resource.

Article 4 Zoning Districts and Use Regulations

- Section 10.410 Establishment and Purpose of Districts
- Section 10.420 District Location and Boundaries
- Section 10.430 Use Regulations
- Section 10.440 Table of Uses – Residential, Mixed Residential, Business and Industrial Districts
- Section 10.450 Table of Uses – Pease/Airport Districts
- Section 10.460 Table of Uses – Municipal and Conservation Districts
- Section 10.470 Uses Permitted in the Transportation Corridor District

Section 10.410 Establishment and Purpose of Districts

The City of Portsmouth is hereby divided into the following zoning districts (the statements of purpose are for descriptive purposes and are not regulatory):

District	Purpose
Residential Districts	
Rural Residential	R To provide areas for single-family dwellings and appropriate accessory uses at rural densities (up to one dwelling per five acres), and limited agricultural uses.
Single Residence A	SRA To provide areas for single-family dwellings at low to medium densities (approximately 1 to 3 dwellings per acre), and appropriate accessory uses .
Single Residence B	SRB
General Residence A	GRA To provide areas for single-family, two-family and multifamily dwellings , with appropriate accessory uses , at moderate to high densities (ranging from approximately 5 to 12 dwelling units per acre), together with appropriate accessory uses and limited services.
General Residence B	GRB
General Residence C	GRC
Garden Apartment/ Mobile Home Park	GA/MI To provide areas for garden apartment development at moderate densities (up to 4 dwelling units per acre), and to accommodate existing developed mobile home parks.
Mixed Use Districts	
Mixed Residential Office	MRO To provide areas where a limited range of business establishments , including live/work units , can be located near or adjacent to residential development , providing a transition between residential neighborhoods and commercial districts.
Mixed Residential Business	MRB

P = Permitted S = Special Exception CU = Conditional Use Permit N = Prohibited

Section 10.440 Table of Uses – Residential, Mixed Residential, Business and Industrial Districts

Use	R	SRA SRB	GRA GRB	GRC (A)	GA/ MH	MRO CD4- L1	CD4- L2	MRB	CD5 CD4	GB	G1	G2	B CD4- W	WB	OR	I	WI	Supplemental Regulations
I. Residential Uses																		
1.10 Single family dwelling	P	P	P	P	N	P	P	P	P	N	P	P	N	N	N	N	N	
1.20 Accessory dwelling unit																		10.814 (Accessory Dwelling Units)
1.21 Attached	CU	CU	CU	CU	N	CU	CU	CU	CU	N	CU	CU	N	N	N	N	N	
1.22 Detached	CU	CU	CU	N	N	N	N	N	N	N	N	N	N	N	N	N	N	
1.25 Garden Cottage	CU	CU	CU	CU	N	CU	CU	CU	CU	N	N	N	N	N	N	N	N	10.815 (Garden Cottages)
1.30 Two-family dwelling	N	N	P	P	P	P	P	P	P	N	P	P	N	N	N	N	N	10.640 (Downtown Overlay district)
1.40 Townhouse	N	N	S	F	P	P	P	P	F	N	P	P	P	N	N	N	N	10.640 (Downtown Overlay district)
1.50 Multifamily dwelling																		
1.51 3 or 4 dwelling units	N	N	S	F	P	P	P	P	P	N	P	P	P	N	N	N	N	10.5A32 (Character district permitted uses)
1.52 5 to 8 dwelling units	N	N	N	S	P	P	P	P	P	N	P	P	P	N	N	N	N	10.640 (Downtown Overlay district)
1.53 More than 8 dwelling units	N	N	N	N	P	N	N	N	P	N	P	P	P	N	N	N	N	10.813 (Multifamily Dwellings in the Business District)
1.60 Conversion of a building existing on January 1, 1980, with less than the required minimum lot area per dwelling unit specified in Article 5																		
1.61 To 2 dwelling units	N	N	S	S	N	P	P	P	S	N	N	N	N	N	N	N	N	10.640 (Downtown Overlay District) 10.812 (Conversion of Existing Dwelling to Multifamily Dwelling)

P = Permitted S = Special Exception CU = Conditional Use Permit N = Prohibited

Use	R	SRA SRB	GRA GRB	GRC (A)	GA/ MH	MRO CD4- L1	CD4- L2	MRB	CD5 CD4	GB	G1	G2	B CD4- W	WB	OR	I	WI	Supplemental Regulations
1.62 To 3 or 4 dwelling units	N	N	S	S	N	P	P	P	S	N	N	N	N	N	N	N	N	
1.63 To 5 to 8 dwelling units	N	N	N	S	N	S	S	S	S	N	N	N	N	N	N	N	N	
1.64 To more than 8 dwelling units	N	N	N	N	N	N	N	N	N	N	N	N	N	N	N	N	N	
1.70 Livework unit	N	N	N	E	N	P	P	P	P	N	P	P	P	N	N	N	N	
1.80 Manufactured housing park	N	N	N	N	P	N	N	N	N	N	N	N	N	N	N	N	N	10.816 (Manufactured Housing Park Dimensional Standards)
1.90 Planned unit development (PUD)																		10.720 (Planned Unit Developments)
1.91 Open space PUD	CU	CU	N	N	N	N	N	N	N	N	N	N	N	N	N	N	N	
1.92 Residential density incentive PUD	N	N	CU	N	N	N	N	N	N	N	N	N	N	N	N	N	N	
2. Institutional Residence or Care Facilities																		
2.10 Assisted living facility																		
2.11 Assisted living center	N	N	N	N	N	N	N	N	P	P	S	S	P	N	N	N	N	
2.12 Assisted living home	S	S	S	S	S	S	S	S	N	N	S	S	N	N	N	N	N	
2.20 Residential care facility																		
2.21 5 or fewer residents	S	S	S	S	S	S	S	S	N	N	S	S	S	N	N	N	N	
2.22 More than 5 residents	N	N	N	N	N	S	S	S	P	S	S	S	S	N	S	N	N	

P = Permitted S = Special Exception CU = Conditional Use Permit N = Prohibited

Use	R	SRA SRB	GRA GRB	CXC (A)	GA/ MH	MRO (CD4- L1	CD4- L2	MRB	CD5 CD4	GB	G1	G2	B CD4- W	WB	OR	I	WI	Supplemental Regulations
3. Educational, Religious, Charitable, Cultural and Public Uses																		
3.10 Place of assembly																		
3.11 Religious	S	S	S	N	N	S	S	S	S	S	S	S	S	N	N	N	N	
3.12 Other nonprofit	N	N	N	N	N	S	S	S	S	S	S	S	S	N	N	N	N	
3.20 School																		
3.21 Primary or secondary	N	N	N	N	N	S	S	P	P	P	S	S	P	P	N	N	N	
3.30 Post-secondary	N	N	N	N	N	S	S	P	P	P	S	S	P	N	P	P	N	
3.30 Historic preservation building	S	S	S	S	S	P	P	P	P	P	P	P	P	N	P	N	N	10.821 (Historic Preservation Buildings and Museums)
3.40 Museum	N	N	N	N	N	P	P	N	P	P	S	S	P	N	P	N	N	10.821 (Historic Preservation Buildings and Museums)
3.50 Performance facility																		
3.51 Indoor performance facility																		
3.511 Occupancy up to 500 persons	N	N	N	N	N	N	N	N	P	P	S	S	S	N	N	N	N	10.592 (location) 10.860 (hours of operation)
3.512 Occupancy more than 500	N	N	N	N	N	N	N	N	S	P	N	N	N	N	N	N	N	
3.52 Outdoor performance facility																		
3.521 Occupancy up to 500 persons	N	N	N	N	N	N	N	N	S	S	S	S	N	N	N	N	N	10.592 (location) 10.822 (yards)
3.522 Occupancy more than 500	N	N	N	N	N	N	N	N	S	S	N	N	N	N	N	N	N	10.860 (hours of operation)

P = Permitted S = Special Exception CU = Conditional Use Permit N = Prohibited

Use	R	SRA SRB	GRA GRB	GRC (A)	GA/ MH	MRO CD4- L1	CD4- L2	MRB	CD5 CD4	GB	G1	G2	B CD4- W	WB	OR	I	WI	Supplemental Regulations
3.60 Cemetery	S	S	N	N	N	N	N	N	N	N	N	N	N	N	N	N	N	
3.70 Club, fraternal or service organization	N	N	N	N	N	N	S	S	P	S	S	S	S	N	N	N	N	
3.80 Municipally operated park and related activities	P	P	P	P	P	P	P	P	P	P	P	P	P	P	P	P	P	For other municipal uses see Section 10.460 (Municipal districts)
4. Recreational Uses																		
4.10 Religious, sectarian or private non-profit recreational use	N	S	N	N	N	S	S	N	P	P	S	S	P	N	N	N	N	
4.20 Cinema or similar indoor amusement use with no live performance	N	N	N	N	N	N	N	N	P	P	S	S	P	N	N	N	N	10.825 (noise) 10.860 (hours of operation)
4.30 Indoor recreation use, such as bowling alley or arcade	N	N	N	N	N	N	N	N	P	P	S	S	P	N	N	N	N	10.825 (noise) 10.860 (hours of operation)
4.40 Health club, yoga studio, martial arts school, or similar use																		
4.41 Up to 2,000 sq. ft. GFA*	N	N	N	N	N	S	S	P	P	P	P	P	N	N	S	N		
4.42 More than 2,000 sq. ft. GFA	N	N	N	N	N	N	N	N	S	P	S	S	S	N	N	S	N	
4.50 Outdoor recreation use	N	N	N	N	N	N	N	N	N	S	P	P	N	N	N	N	N	10.592 (location) 10.860 (hours of operation)
4.60 Amusement park, water park or theme park	N	N	N	N	N	N	N	N	N	N	N	N	N	N	N	N	N	

*GFA = gross floor area.

P = Permitted S = Special Exception CU = Conditional Use Permit N = Prohibited

Use	R	SRA SRB	GRA GRB	GRC (A)	GA/ MH	MRO CD4- L1	CD4- L2	MRH	CD5 CD4	GB	G1	G2	B CD4- W	WB	OR	I	WI	Supplemental Regulations
5. Office Uses, Non-Medical																		
5.10 Professional office	N	N	N	N	N	P	P	S	P	P	P	P	P	N	P	P	N	10.833 (Mixed Residential districts)
5.20 Business office (incl. real estate office)	N	N	N	N	N	P	P	P	P	P	P	P	P	N	P	P	N	10.833 (Mixed Residential districts)
5.30 Financial Institution																		
5.31 Financial services office	N	N	N	N	N	P	P	P	P	P	P	P	N	P	P	N		
5.32 Retail bank	N	N	N	N	N	N	S	P	P	P	P	P	N	S	N	N		
5.40 Social service campus																		
5.41 Nonresidential	N	N	N	N	N	N	N	N	N	N	N	N	N	N	N	P	N	10.823
5.42 Residential	N	N	N	N	N	N	N	N	N	N	N	N	N	N	N	S	N	
5.50 Media studio																		
5.51 Excluding any transmitting antenna tower	N	N	N	N	N	S	S	S	P	P	S	S	P	N	N	P	N	
5.52 Including accessory transmitting antenna tower	N	N	N	N	N	N	N	N	N	S	N	N	S	N	N	S	N	10.834
5.60 Publishing facility or similar electronic production operation	N	N	N	N	N	S	S	S	P	P	P	P	P	N	P	P	N	
5.70 Call Center	N	N	N	N	N	N	N	N	N	P	N	N	N	N	N	S	N	
6. Medical Services and Health Care																		
6.10 Hospital	N	N	N	N	N	N	N	N	N	N	N	N	N	N	P	N	N	

P = Permitted S = Special Exception CU = Conditional Use Permit N = Prohibited

Use	R	SRA SRB	GRA GRB	GRC (A)	GA/ MH	MRO	CD4-	MRB	CD5	GB	GI	G2	B	WB	OR	I	WI	Supplemental Regulations
						CD4- LI	L2		CD4				CD4- W					
6.20 Medical offices and clinics (outpatient only)	N	N	N	N	N	S	S	S	P	P	P	P	P	N	P	N	N	
6.30 Clinics with inpatient care	N	N	N	N	N	N	N	N	N	S	S	N	S	N	S	N	N	
6.40 Ambulatory surgical center	N	N	N	N	N	N	N	N	N	S	S	N	S	N	S	N	N	
6.50 Substance abuse treatment facility	N	N	N	N	N	N	N	N	N	N	N	N	N	N	N	N	N	
6.60 Psychiatric hospital for the criminally insane	N	N	N	N	N	N	N	N	N	N	N	N	N	N	N	N	N	
7. Services, Other Than Health Care																		
7.10 Day Care																		
7.11 Family day care facility	P	P	P	N	N	P	P	P	N	N	P	P	N	N	N	N	N	
7.12 Group day care facility including private preschool and kindergarten	S	S	S	S	N	S	S	P	P	P	S	S	P	N	N	N	N	10.824 (group day care facilities) 10.860 (hours of operation)
7.20 Personal services	N	N	N	N	N	N	S	S	P	P	P	S	P	N	N	N	N	
7.30 Consumer services such as copy shop, bicycle repair, and pet grooming	N	N	N	N	N	N	S	S	P	P	P	S	P	N	N	N	N	
7.40 Trade, craft and general service establishments, such as shops for plumbers, electricians, painters, paper hangers, upholsterers, sign painters and printers	N	N	N	N	N	N	N	S	P	P	P	S	P	N	P	P	P	All storage of materials and equipment shall be located within a building

P = Permitted S = Special Exception CU = Conditional Use Permit N = Prohibited

Use	R	SRA SRB	GRA GRB	GRC (A)	GA/ MII	MRO CD4- L1	CD4- L2	MRB	CD5 CD4	GB	G1	G2	B CD4- W	WB	OR	I	WI	Supplemental Regulations
7.50 Veterinary Care	N	N	N	N	N	N	N	S	N	S	S	S	S	N	S	S	N	10.832
7.60 Laundry and dry cleaning establishments																		
7.61 Drop-off/pick-up only for items to be dry cleaned or laundered off site	N	N	N	N	N	P	P	P	P	P	P	P	P	N	S	N	N	
7.62 Self-service laundry for use by the general public	N	N	N	N	N	S	S	P	S	P	P	S	P	N	N	N	N	
7.63 Dry cleaning establishment with on-site cleaning facilities.	N	N	N	N	N	N	N	N	N	N	N	N	N	N	N	N	N	
7.70 Undertaking establishment, funeral parlor or mortuary chapel, excluding crematorium	N	N	N	N	N	N	N	P	N	P	S	S	P	N	N	N	N	
8. Retail Trade																		
8.10 Convenience goods																		10.860 (hours of operation)
8.11 Convenience goods 1																		
8.111 Hours of operation between 6:00 AM and 11:00 PM	N	N	N	N	N	N	P	P	P	P	P	P	P	N	N	N	N	
8.112 24 hours per day operation	N	N	N	N	N	N	N	N	P	P	S	N	S	N	N	N	N	
8.12 Convenience goods 2																		
8.121 Hours of operation between 6:00 AM and 11:00 PM	N	N	N	N	N	N	P	S	P	P	P	P	P	N	N	N	N	

P = Permitted S = Special Exception CU = Conditional Use Permit N = Prohibited

Use	R	SRA SRB	GRA GRD	GRC (A)	GAU MI	MRO CD4- L1	CD4- L2	MRB	CD5 CD4	GB	G1	G2	B CD4- W	WB	OR	I	W1	Supplemental Regulations
8.122 24 hours per day operation	N	N	N	N	N	N	N	N	S	S	S	N	S	N	N	N	N	
8.30 Retail sales conducted within a building																		
8.31 Not marine-related	N	N	N	N	N	N	P	S	P	P	P	P	P	N	N	N	N	
8.32 Marine-related	N	N	N	N	N	N	N	N	P	P	P	P	P	P	N	N	N	
8.40 Shopping center	N	N	N	N	N	N	N	N	P	P	P	P	S	N	N	N	N	
8.50 Retail sales, large format	N	N	N	N	N	N	N	N	N	S	N	N	N	N	N	N	N	
8.60 Fish market	N	N	N	N	N	N	N	N	P	P	P	P	P	P	N	N	N	10.860 (hours of operation)
8.70 Manufacture of goods sold at retail on the premises, such as crafts, coffee roasting and bakery goods	N	N	N	N	N	N	S	S	P	P	P	P	P	N	N	P	N	Maximum of 5 persons employed in manufacture
8.80 Sexually oriented business	N	N	N	N	N	N	N	N	N	S	N	N	N	N	N	N	N	10.930 (Sexually Oriented Businesses)
9. Eating and Drinking Places																		
9.10 Nightclub or bar																		10.590 (location)
9.11 Occupant load less than 250	N	N	N	N	N	N	N	N	P	P	P	S	N	N	N	N	N	
9.12 Occupant load from 250 to 500	N	N	N	N	N	N	N	N	S	S	S	S	N	N	N	N	N	
9.13 Occupant load greater than 500	N	N	N	N	N	N	N	N	N	N	N	N	N	N	N	N	N	
9.20 Restaurant, take-out only	N	N	N	N	N	N	N	N	P	P	P	P	P	N	N	N	N	
9.30 Restaurant, fast food	N	N	N	N	N	N	N	N	P	P	P	P	P	N	N	N	N	

P = Permitted S = Special Exception CU = Conditional Use Permit N = Prohibited

Use	R	SRA SRB	GRA GRB	G/C (A)	GA/ MH	MRO CD4- L1	CD4- L2	MRB	CD5 CD4	GB	G1	G2	B CD4- W	WB	OR	I	WI	Supplemental Regulations
9.40 Restaurant, place of public assembly or function room																		10.590 (location) 10.860 (hours of operation)
9.41 Occupant load less than 50	N	N	N	N	N	N	P	N	P	P	P	P	P	N	N	N	N	
9.42 Occupant load from 50 to 250	N	N	N	N	N	N	N	N	P	P	P	S	S	N	N	N	N	
9.43 Occupant load from 250 to 500	N	N	N	N	N	N	N	N	P	S	S	S	N	N	N	N	N	
9.44 Occupant load greater than 500	N	N	N	N	N	N	N	N	S	S	N	N	N	N	N	N	N	
9.50 Permanently moored vessel used as restaurant or bar, with occupant load less than 250	N	N	N	N	N	N	N	N	N	N	N	N	N	N	N	N	N	
10. Lodging Establishments																		
10.10 Boarding house	N	N	N	N	N	N	N	N	N	S	S	N	S	N	N	N	N	
10.20 Bed and breakfast																		
10.21 Bed and Breakfast 1	N	N	S	N	N	S	S	P	P	N	S	S	P	N	N	N	N	
10.22 Bed and Breakfast 2	N	N	N	N	N	S	S	P	P	N	S	S	P	N	N	N	N	
10.30 Inn	N	N	N	N	N	N	S	S	P	P	S	S	P	N	N	N	N	
10.40 Hotel or motel																		10.836 (Office Research districts)
10.41 Up to 125 rooms	N	N	N	N	N	N	N	N	P	S	S	S	N	N	N	P	N	N
10.42 126 to 250 rooms	N	N	N	N	N	N	N	N	P	S	S	S	N	N	N	S	N	N
10.42 251 to 500 rooms	N	N	N	N	N	N	N	N	P	S	S	N	N	N	N	N	N	N
10.43 More than 500 rooms	N	N	N	N	N	N	N	N	P	S	S	N	N	N	N	N	N	N

P = Permitted S = Special Exception CU = Conditional Use Permit N = Prohibited

Use	R	SRA SRB	GRA GRB	GRC (A)	GA/ MH	MRO CD4- L1	CD4- L2	MRB	CD5 CD4	GB	GI	G2	H CD4- W	WB	OR	I	WI	Supplemental Regulations
10.50 Conference hotel	N	N	N	N	N	N	N	N	P	P	S	N	N	N	N	N	N	
10.60 Conference center	N	N	N	N	N	N	N	N	P	P	S	N	N	N	N	N	N	
11. Motor Vehicle-Related Uses																		
11.10 Sales, renting or leasing of passenger cars and light trucks, motorcycles, tractors, snowmobiles and small power equipment (e.g., lawnmowers), including accessory repair services	N	N	N	N	N	N	N	N	N	P	S	N	S	N	N	N	N	10.592 (location) 10.843 (motor vehicle related uses)
11.20 Motor vehicle service station, motor vehicle repair or washing facility for passenger cars and light trucks	N	N	N	N	N	N	N	N	N	S	S	N	S	N	N	S	N	10.581 (lot area) 10.592 (location) 10.843 (motor vehicle related uses)
11.30 Sales, rental, leasing, distribution, and repair of trucks over 10,000 lb gross vehicle weight (GVW), recreational vehicles, marine craft or manufactured housing, and related equipment	N	N	N	N	N	N	N	N	N	S	S	N	S	N	N	S	N	10.581 (lot area) 10.592 (location) 10.843 (motor vehicle related uses)
11.40 Impound lot (principal or accessory use)	N	N	N	N	N	N	N	N	N	N	N	N	N	N	N	S	N	
11.50 Truck fueling facility	N	N	N	N	N	N	N	N	N	N	N	N	N	N	N	S	N	10.581 (lot area) 10.592 (location) 10.843 (motor vehicle related uses)

P = Permitted S = Special Exception CU = Conditional Use Permit N = Prohibited

Use	R	SRA SRB	GRA GRB	GRC (A)	GA/ MH	MRO	CD4-	MRB	CD5	GB	GI	G2	B	WB	OR	I	WI	Supplemental Regulations
						CD4- L1	L2		CD4				CD4- W					
11.60 Truck terminal	N	N	N	N	N	N	N	N	N	N	N	N	N	N	N	S	N	10.592 (location) 10.843 (motor vehicle related uses)
12. Marine Craft Related Uses																		
12.10 Boat landings, boat docks, boathouses and associated marine uses																		
12.11 Non-commercial	P	P	P	P	P	P	P	P	P	P	P	P	P	N	N	N	N	
12.12 Fishing boat landing 1	N	S	S	N	N	N	N	N	P	P	N	N	N	P	N	N	P	10.837.10 (Residential districts)
12.13 Fishing boat landing 2	N	N	N	N	N	N	N	N	N	S	N	N	N	S	N	N	P	
12.20 Marina																		
12.21 With no repair, servicing or fueling facilities	N	N	N	N	N	N	N	N	N	N	N	N	N	P	N	N	N	
12.22 With repair, servicing or fueling facilities	N	N	N	N	N	N	N	N	N	N	N	N	N	S	N	N	N	10.581 (lot area) 10.592 (location) 10.860 (hours of operation)
12.30 Repair of commercial marine craft and marine-related structures	N	N	N	N	N	N	N	N	N	N	N	N	N	S	N	S	P	10.581 (lot area) 10.592 (location) 10.860 (hours of operation)
12.40 Landside support facility for commercial passenger vessel	N	N	N	N	N	N	N	N	N	N	N	N	N	P	N	N	P	

P = Permitted S = Special Exception CU = Conditional Use Permit N = Prohibited

Use	R	SRA SRB	GRA GRB	GRC (A)	GA/ MH	MRO CD4- L1	CD4- L2	MRH	CD5 CD4	GB	G1	G2	B CD4- W	WB	OR	I	WI	Supplemental Regulations
13. Wholesale Trade, Warehousing and Distribution																		
13.10 Wholesale use																		
13.11 Not marine-dependent	N	N	N	X	N	N	N	N	N	N	N	N	N	N	N	P	N	
13.12 Marine-dependent	N	N	N	X	N	N	N	N	N	N	N	N	N	N	N	P	P	
13.20 Wholesale sales devoted to, and in the same establishment as, a permitted retail use																		
13.21 Occupying up to 20% of gross floor area of establishment	N	N	N	X	N	N	N	N	P	P	S	N	P	N	N	N	N	
13.22 Occupying 21% to 40% of gross floor area of establishment	N	N	N	X	N	N	N	N	N	P	N	N	P	N	N	N	N	
13.30 Wholesale lumber yards, lumber and contractor sales																		
13.31 Not marine-dependent	N	N	N	X	N	N	N	N	N	N	N	N	N	N	N	P	N	
13.32 Marine-dependent	N	N	N	X	N	N	N	N	N	N	N	N	N	N	N	P	S	
13.40 Warehousing or distribution of non-flammable, non-hazardous materials, not classified as a high hazard use																		
13.41 Not marine-dependent	N	N	N	X	N	N	N	N	N	N	N	N	N	N	N	P	N	

P = Permitted S = Special Exception CU = Conditional Use Permit N = Prohibited

Use	R	SRA SRB	GRA GRB	GRC (A)	GA/ MH	MRO CD4- L1	CD4- L2	MRB	CD5 CD4	GB	G1	G2	B CD4- W	WB	OR	I	WI	Supplemental Regulations
13.42 Marine-dependent	N	N	N	N	N	N	N	N	N	N	N	N	N	N	N	P	P	
14. Industrial Uses																		
14.10 Light industry																		
14.11 Not marine-dependent	N	N	N	N	N	N	N	N	N	S	S	S	N	N	N	P	N	
14.12 Marine-dependent	N	N	N	N	N	N	N	N	N	S	N	N	N	N	N	P	P	
14.20 Research and development																		
14.21 Not marine-dependent	N	N	N	N	N	N	N	P	N	S	S	N	S	N	S	P	N	
14.22 Marine-dependent	N	N	N	N	N	N	N	N	N	S	N	N	S	P	S	P	P	
14.30 Food processing																		
14.31 Not including seafood processing	N	N	N	N	N	N	N	N	N	P	S	N	N	N	N	P	P	10.592 (location) 10.851 (use contained in building)
14.32 Including seafood processing	N	N	N	N	N	N	N	N	N	S	N	N	N	N	N	S	S	
14.40 Electronics manufacturing																		
14.40 Electronics manufacturing	N	N	N	N	N	N	N	N	N	S	S	N	S	N	N	P	N	
14.50 General manufacturing																		
14.51 Not marine-dependent	N	N	N	N	N	N	N	N	N	N	S	S	N	N	N	P	N	
14.52 Marine-dependent	N	N	N	N	N	N	N	N	N	N	N	N	N	P	N	P	S	
14.60 Biological or chemical laboratory																		

P = Permitted S = Special Exception CU = Conditional Use Permit N = Prohibited

Use	R	SRA SRB	GRA GRB	GIC (A)	GA/ MH	MRO CD4- L1	CD4- L2	MRB	CD5 CD4	GB	G1	G2	B CD4- W	WB	OR	I	WI	Supplemental Regulations
14.61 Not marine-dependent	N	N	N	R	N	N	N	N	N	N	N	N	N	N	N	S	N	
14.62 Marine-dependent	N	N	N	N	N	N	N	N	N	N	N	N	N	N	N	S	S	
14.70 Recycling facility or recycling plant	N	N	N	N	N	N	N	N	N	N	N	N	N	N	N	S	N	10.592 (location) 10.853
14.80 High hazard use, including other uses listed in this section but not including uses described in 14.90	N	N	N	N	N	N	N	N	N	N	N	N	N	N	N	S	N	10.593 (location)
14.90 Storage (other than normal accessory use), processing, disposal, or transfer of petroleum, petrochemicals, natural gas and liquid petroleum products, coal, alcohol, wood pulp, solid or liquid waste, junk or hazardous waste as classified by Federal or State law	N	N	N	N	N	N	N	N	N	N	N	N	N	N	N	N	N	
15. Transportation and Utilities																		
15.10 Public or private transformer station, substation, pumping station or automatic telephone exchange, not including any business office, storage yard or storage building																		
15.11 Essential to service the area in which it is located	S	S	S	S	S	S	S	S	S	S	S	S	S	S	S	P	S	

P = Permitted S = Special Exception CU = Conditional Use Permit N = Prohibited

Use	R	SRA SRB	GRA GRB	GRC (A)	GA/ MH	MRO CD4- L1	CD4- L2	MRB	CD5 CD4	GB	G1	G2	B			I	WI	Supplemental Regulations
													CD4- W	WB	OR			
15.12 Providing community-wide or regional service	N	N	N	N	N	N	N	N	N	S	N	N	N	N	N	S	S	
15.20 Helipad or helipad																		
15.21 Helipad, as an accessory use to a permitted hospital use	N	N	N	N	N	N	N	N	N	N	N	N	N	N	S	S	S	
15.22 Helipad	N	N	N	N	N	N	N	N	N	N	N	N	N	N	N	N	N	
16. Wireless Telecommunications Facilities																		
16.10 Satellite dish receiver 42 inches or less in diameter:																		
16.11 Building-mounted, maximum height less than or equal to 4 feet from the roof surface	P	P	P	P	P	P	P	P	P	P	P	P	P	P	P	P	P	
16.12 Ground-mounted, complying with all yard requirements for the district	P	P	P	P	P	P	P	P	P	P	P	P	P	P	P	P	P	
16.20 Satellite dish receiver more than 42 inches in diameter:																		
16.21 Building-mounted, maximum height less than or equal to 4 feet from the roof surface	S	S	S	S	S	S	S	S	S	S	S	S	S	S	S	S	S	

P = Permitted S = Special Exception CU = Conditional Use Permit N = Prohibited

Use	R	SRA SRB	GRA GRB	GRC (A)	GA/ MH	MRO CD4- L1	CD4- L2	MRB	CD5 CD4	GB	GI	G2	B CD4- W	WB	OR	I	WI	Supplemental Regulations
16.22 Ground-mounted, complying with all yard requirements for the district	S	S	S	S	S	S	S	S	S	S	S	S	S	S	S	S	S	
16.30 Whip antenna not more than 30 feet in height	S	S	S	S	S	S	S	S	P	P	S	S	P	P	P	P	P	
16.40 Other wireless telecommunications facility not included above	N	N	N	N	N	N	N	N	N	N	N	N	N	N	N	N	N	10.460 (Municipal districts) 10.920 (Wireless telecommunications facilities)
17. Agricultural Uses																		
17.10 Farm, not including the keeping of farm animals	P	P	N	N	N	N	N	N	N	N	N	N	N	N	N	N	N	
17.20 Keeping of farm animals	S	S	N	N	N	N	N	N	N	N	N	N	N	N	N	N	N	
18. Temporary Uses																		
18.10 Construction trailer	P	P	P	P	P	P	P	P	P	P	P	P	P	P	P	P	P	
18.20 Temporary structure																		
18.21 Up to 30 days	P	P	P	P	P	P	P	P	P	P	P	P	P	P	P	P	P	
18.22 31 to 90 days	S	S	S	S	S	S	S	S	S	S	S	S	S	S	P	P	P	
18.23 91 to 180 days	N	N	N	N	N	N	N	N	N	N	N	N	N	N	S	S	S	
18.24 More than 180 days	N	N	N	N	N	N	N	N	N	N	N	N	N	N	N	N	N	

P = Permitted S = Special Exception CU = Conditional Use Permit N = Prohibited

Use	R	SRA SRB	GRA GRB	GRC (A)	GA/ MH	MRO CD4- LI	CD4- L2	MRH	CD5 CD4	GB	G1	G2	B CD4- W	WB	OR	I	W1	Supplemental Regulations
18.30 Manufactured housing not on a foundation, as temporary replacement housing for a dwelling on the same lot destroyed by natural causes, provided that there is an active building permit for rebuilding the destroyed dwelling																		
18.31 Up to 180 days	P	P	P	P	P	P	P	P	P	P	P	P	P	P	P	P	P	
18.32 More than 180 days	S	S	S	S	S	S	S	S	S	S	S	S	S	S	P	P	P	
18.40 Cars or trailers, including outdoor display area, used for the seasonal sale of dry goods, Christmas trees, flowers, fruits, vegetables, seasonal products and prepared food	N	N	N	N	N	N	N	N	P	P	S	N	P	N	P	P	P	
19. Accessory Uses																		
19.10 Accessory use to a permitted principal use, but not including any outdoor storage	P	P	P	P	P	P	P	P	P	P	P	P	P	P	P	P	P	10.811 (residential accessory uses)
19.20 Home occupation																		
19.21 Home occupation 1	P	P	P	P	P	P	P	P	P	P	P	P	P	N	N	N	N	
19.22 Home occupation 2	S	S	S	S	N	S	S	P	P	P	P	P	P	N	N	N	N	
19.30 Concessions and services located within the principal building	N	N	N	P	P	P	P	P	P	P	P	P	P	P	P	P	P	

P = Permitted S = Special Exception CU = Conditional Use Permit N = Prohibited

Use	R	SRA SRB	GRA GRB	G&C (A)	GA/ MH	MRO CD4- L1	CD4- L2	MRB	CD5 CD4	GB	G1	G2	B			I	WI	Supplemental Regulations
													CD4- W	WB	OR			
19.40 Drive-through facility, as accessory use to a permitted principal use	N	N	N	N	N	N	N	N	N	CU	CU	N	CU	N	CU	N	N	10.835 (accessory drive-through uses)
19.50 Outdoor dining or drinking area, as accessory use to a permitted principal use	N	N	N	N	N	N	CU	N	P	P	P	P	CU	N	N	N	N	
20. Accessory Storage																		
20.10 Indoor storage of motor vehicles or boats as an accessory use	P	P	P	P	P	P	P	P	P	P	P	P	P	P	P	P	P	
20.20 Outdoor storage of registered motor vehicles owned by residents of the premises or business. Such vehicles may include only one commercial vehicle, which shall be limited to no more than 2 axles and 6 wheels.	P	P	P	P	P	P	P	P	P	P	P	P	P	P	P	P	P	
20.30 Outdoor storage for not more than 9 consecutive months of boats owned by residents of the property:																		
20.31 Not more than one motorboat or sailboat longer than 12 feet	P	P	P	P	P	P	P	P	P	P	P	P	P	P	P	P	P	
20.32 Any number of (a) motorboats or sailboats up to 12 feet in length, or (b) hand-powered craft (canoes and kayaks) without restriction as to length	P	P	P	P	P	P	P	P	P	P	P	P	P	P	P	P	P	

P = Permitted S = Special Exception CU = Conditional Use Permit N = Prohibited

Use	R	SRA SRB	GRA GRB	GRC (A)	GAV MH	MRO CD4- L1	CD4- L2	MRB	CD5 CD4	GB	G1	G2	B			I	WI	Supplemental Regulations
													CD4- W	WB	OR			
20.40 Outdoor storage of lobster traps, lobster buoys and associated rope	P	P	P	P	P	P	P	P	N	P	P	P	P	P	N	P	P	10.811.20
20.50 Outdoor storage of raw or partially finished material																		
20.51 Not marine-dependent	N	N	N	N	N	N	N	N	N	N	N	N	N	N	N	S	N	
20.52 Marine-dependent	N	N	N	N	N	N	N	N	N	N	N	N	N	S	N	S	S	
20.60 Outdoor storage of machinery, equipment and vehicles																		
20.61 Not marine-dependent	N	N	N	N	N	N	N	N	N	S	N	N	S	N	N	S	N	
20.62 Marine-dependent (other than allowed by 20.30 or 20.40 above)	N	N	N	N	N	N	N	N	N	S	N	N	S	S	N	S	S	

HOEFLE, PHOENIX, GORMLEY & ROBERTS, PLLC
ATTORNEYS AT LAW

127 Parrott Avenue, P.O. Box 4480 | Portsmouth, NH, 03802-4480
Telephone: 603.436.0666 | Facsimile: 603.431.0879 | www.hpgrlaw.com

October 26, 2022

HAND DELIVERED

Peter Stith, Principal Planner
Portsmouth Zoning Board of Adjustment
1 Junkins Avenue
Portsmouth, NH 03801

Re: 635 Sagamore Development, LLC, Owner/Applicant
Project Location: 635 Sagamore Avenue
Tax Map 222, Lot 19
General Residence A (GRA Zone)

Dear Mr. Stith and Zoning Board Members:

On behalf of 635 Sagamore Development, LLC, applicant, enclosed please find the following documents in support of a request for zoning relief:

- Portsmouth Land Use Application uploaded to Viewpoint today.
- Owner Authorization.
- 10/26/2022 – Memorandum and exhibits in support of zoning relief.

Very truly yours,

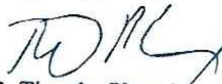
R. Timothy Phoenix
Monica F. Kieser

Enclosures

cc 635 Sagamore Development, LLC
Jones & Beach Engineers, Inc.
Artform Architecture, Inc.

DANIEL C. HOEFLE
R. TIMOTHY PHOENIX
LAWRENCE B. GORMLEY
STEPHEN H. ROBERTS

R. PETER TAYLOR
KEVIN M. BAUM
GREGORY D. ROBBINS
MONICA F. KIESER

JACOB J.B. MARVELLEY
DUNCAN A. EDGAR
STEPHANIE J. JOHNSON

OF COUNSEL:
SAMUEL R. REID
JOHN AHLGREN

Letter of Authorization

635 Sagamore Development, LLC, owner of property located at 635 Sagamore Avenue in Portsmouth, NH, known as Tax Map 222, Lot 19, do hereby authorize Jones & Beach Engineers, Inc. ("JBE"), Garrepy Planning Consultants, LLC ("GPC"), and Hoefle, Phoenix, Gormley & Roberts, PLLC ("HPGR") to act on its behalf concerning the previously mentioned property.

I hereby appoint JBE, GPC and HPGR as agents to act on behalf of 635 Sagamore Development, LLC in the Planning Board and Zoning Board application process, to include any required signatures.

635 Sagamore Development, LLC



Timothy J. Black, Duly Authorized

January 5, 2022
Date

MEMORANDUM

To: Portsmouth Zoning Board of Adjustment (“ZBA”)
From: R. Timothy Phoenix, Esq.
Monica F. Kieser, Esq.
Date: October 26, 2022
Re: 635 Sagamore Development, LLC, Owner/Applicant
Project location: 635 Sagamore Avenue
Tax Map 222, Lot 19
Single Residence A (SRA) District

Dear Chairman Parrott and Zoning Board Members:

On behalf of 635 Sagamore Development, LLC (“635 Sagamore” or “Applicant”) we are pleased to submit this memorandum and the attached exhibits in support of zoning relief to be considered by the ZBA at its November 15, 2022 meeting.

I. EXHIBITS

- A. Plan Set –by Jones and Beach Engineers
 - C1 – Existing Conditions Plan
 - C2 – ZBA Site Plan
 - C3 – Topographic Site Plan
- B. Architectural Elevations and Floor Plans-by ArtForm Architecture, Inc.
 - Renderings
 - First Floor
 - Second Floor
 - Foundation Plan
 - Elevations
- C. Site photographs
- D. Tax Assessors Card
- E. City GIS Map – identifying nearby zoning districts and surrounding area

II. PROPERTY/BACKGROUND

635 Sagamore Avenue is an 84,795 s.f lot with 150 ft. of frontage containing two buildings in poor condition; the front building contains Luster King, an automobile detailing shop and upstairs apartment, and behind a large service garage (the “Property”). The Luster King building is located partially within the front yard setback, access to it is over the entire frontage, and the use of the Property does not conform to the requirements of the Single Residence A District. 635 Sagamore proposes to remove the existing commercial building and garage and redevelop the Property with four new single-family homes with access via a private roadway from Sagamore Avenue (the “Project”). (Exhibit A). The Project is more compatible

with the neighborhood which includes the westerly abutter, Tidewatch Condominiums with 122 Units, and the Sagamore Court Condominium with 144 Units. **(Exhibit D)**. Other nearby abutters are largely developed with single family residences with similar density as the proposed project. The Luster King building is still served by septic, but municipal sewer service has been extended to the Property which will serve the proposed dwellings.

In March of this year, 635 Sagamore filed a variance application seeking relief from §10.513 and §10.521 (Dimensional Table) to permit five dwellings on the Property where one dwelling is required and 16,959 s.f. per dwelling unit where 43,560 s.f. per dwelling is required. Thereafter, Tidewatch Condominium Association (“Tidewatch”) objected, through Counsel Brian Bouchard. 635 Sagamore withdrew the previous application in order to spend time working with Tidewatch to address its concerns. 635 Sagamore now proposes a twenty percent (20%) reduction four-unit residential development which retains a significant tree buffer and adds a mix of trees on the south and west side of the lot (the “Revised Project”). Given the reduction in units and generous plantings, Tidewatch Condominium Association has withdrawn its objection to the Revised Project, provided 635 Sagamore continues to coordinate with Tidewatch on issues related to landscaping and stormwater management.

The Revised Project requires similar relief as before as four dwelling units are proposed on a ±1.947 acre lot (2.06 units per acre or 21,198 s.f. per dwelling). This density is less than nearby densely developed Sagamore Court Condominium (144 units/15.01 acre = 9.59 units per acre or 4,542 s.f. per dwelling) to the north and Tidewatch Condominium (122 units/53.59 acre = 2.27 units per acre or 19,189 s.f. per dwelling) directly to the west. Notably, the SRB Zone, located across Sagamore Avenue, permits a lot area of 15,000 square feet per dwelling unit or approximately 2.9 units per acre. The proposal at 21,198 s.f. square feet per unit falls between the single-family homes opposite the lot and the more densely developed condominium associations. Thus, in addition to cleaning up a long distressed and non-conforming site, including narrowing the current open frontage curb cut, the proposal creates a natural transition between the SRB Zone across Sagamore, the existing multi-building condominium developments to the north and west (rear) of the Property and the nearby single-family home lots.

III. RELIEF REQUIRED

The Project meets setback, lot coverage, and open space requirements. **(Exhibit A)**. Relief is required to allow the proposed structures on a single lot and for lot area per dwelling unit.

- 1.) **PZO §10.513 One Freestanding Dwelling/Lot** – to permit four dwellings on a 1.947 acre lot.
- 2.) **PZO §10.521 (Table of Dimensional Standards) Lot Area Per Dwelling Unit** – to permit four dwellings on 1.947 acres (21,198 s.f./dwelling area) where 43,560 s.f. is required for each dwelling.

IV. VARIANCE REQUIREMENTS

1. **The variance will not be contrary to the public interest**
2. **The spirit of the ordinances observed**

The first step in the ZBA's analysis is to determine whether granting a variance is not contrary to the public interest and is consistent with the spirit and intent of the ordinance, considered together pursuant to Malachy Glen Associates, Inc v. Town of Chichester, 155 NH 102 (2007) and its progeny. Upon examination, it must be determined whether granting a variance "would unduly and to a marked degree conflict with the ordinance such that it violates the ordinances basic zoning objectives." Id. "Mere conflict with the ordinance is not enough." Id.

The Portsmouth Zoning Ordinance was enacted for the general purpose (PZO§10.121) of promoting the health, safety and welfare in accordance with the Master plan by regulating:

1. **The use of land, buildings and structures for business, industrial, residential and other purposes** – The Property currently houses a non-conforming commercial auto detailing business and service garage. **(Exhibit C)**. The proposal would replace those buildings with brand new, to code, residences consistent with surrounding uses.
2. **The intensity of land use, including lot sizes, building coverage, building height and bulk, yards and open space** – The Project complies with building coverage, height, yards and open space requirements. The reduced proposal with four dwellings on a single lot, at 2.06 dwelling units per acre is consistent with surrounding properties and less than the density permitted by right across Sagamore Avenue.
3. **The design of facilities for vehicular access, circulation, parking and loading-** The Project will be served by a private roadway from Sagamore Avenue. **(Exhibit A)**. There is currently no defined curb cut on the property so the redevelopment will improve driveway distances, site lines, and overall traffic safety from the Property compared to the existing commercial and residential use. **(Exhibit D)**. The driveway will undergo further review as part of the Planning Board and NHDOT review processes.

4. The impacts on properties of outdoor lighting, noise, vibration, stormwater runoff and flooding – The Property is currently used as a commercial auto detailing facility in the middle of a residential area. The Project will convert the Property to residential use with lighting, noise, and other conditions more appropriate for the neighborhood. A generous buffer will be preserved between the Project and Tidewatch Condominium. The Project maintains 81.3% open space. Stormwater runoff will be improved over the current development which is significantly paved and use of commercial cleaning chemicals will cease.
5. The preservation and enhancement of the visual environment – The Project vastly improves the visual environment for the immediate abutters on either side and across the street. In addition, a generous vegetated buffer is retained for the south/west abutters. Sagamore further screens the developed area with the addition of a significant tree buffer. **(Exhibit A).**
6. The preservation of historic districts buildings and structures of historic or architectural interest – The Property and the existing structures to be removed are of no known historic or architectural interest.
7. The protection of natural resources, including groundwater, surface water, wetlands, wildlife habitat and air quality – The Project will significantly improve conditions by terminating the use of commercial grade cleaning chemicals in favor of a compatible residential uses served by municipal sewer.

In considering whether variances "in a marked degree conflict with the ordinance such that they violate the ordinances basic zoning objectives." Malachy Glen, supra, the New Hampshire Supreme Court also held:

One way to ascertain whether granting the variance would violate basic zoning objectives is to examine whether it would alter the essential character of the locality. Another approach to [determine] whether granting the variance violates basic zoning objectives is to examine whether granting the variance would threaten the public health, safety or welfare. (Emphasis Added)

The Property is located on a busy street in a densely developed residential area. While there are some other nearby commercial use properties, they are located closer to Sagamore Creek in the Waterfront Business Zone, are largely less impactful and are more buffered from nearby residences than the current business operations on the Property. The Project would convert a long-standing commercial use that is grossly incompatible with the character of the locality to a residential use consistent with the surrounding area including two large condominium developments. The commercial traffic and the use of commercial grade cleaning chemicals will cease, thus improving the public health, safety and welfare. The wide open curb

cut accessing the lot will be reduced to a controlled entry/exit. The Project creates a natural transition between these condominium developments and the adjoining GRB zone. Thus, permitting four code compliant, single-family dwellings on ±1.947 acres does not alter the essential character of the locality nor will it threaten the public health, safety or welfare.

3. Granting the variances will not diminish surrounding property values

The commercial buildings currently located on the Property are distressed, incongruent with the surrounding residential neighborhood and frankly an eyesore. The Project cleans up the site, removes commercial buildings/uses and replaces them with brand new tastefully designed residences. In consultation with Tidewatch, a generous vegetated buffer is retained, which is supplemented by the addition of a robust landscape buffer plan. Given the termination of the commercial use, removal of the distressed structures, and efforts to screen the residential structures, the Project will increase the value of surrounding properties. Accordingly, this element of the variance criteria is satisfied.

4. Denial of the variances results in an unnecessary hardship

a. Special conditions distinguish the property/project from others in the area-

This portion of the SRA District on the north side of Sagamore Creek is comprised of only seven properties. (**Exhibit E**). Discounting Tidewatch with 122 units on 53.59 acres, the 1.947 acre L-shaped lot significantly larger than the remaining five properties, yet contains just over the required frontage. Although zoned SRA and subject to a 43,560 s.f. minimum lot area and lot area/dwelling unit requirement, this neighborhood is bounded by the Sagamore Condominium Development with 144 Units on 15.01 acres, a handful of lots in the Waterfront Business District, and the SRB district across Sagamore Avenue with its reduced density requirement of just 15,000 s.f./dwelling unit. See Walker v. City of Manchester, 107 N.H. 382, 386 (1966) (hardship may be found where similar nonconforming uses exist within the neighborhood and the proposed use will have no adverse effect on the neighborhood). The parcel size, shape, and location near other densely developed residential parcels combine to create special conditions.

b. No fair and substantial relationship exists between the general public purposes of the ordinance and its specific application in this instance.

The purpose of the requirements for one free standing dwelling per lot and lot area per dwelling unit is to prohibit overcrowding, allow for air, light, and separation between neighbors,

and to permit stormwater treatment. The Project meets all lot area, building and open space coverage, height and external setback requirements. Additionally, the proposal provides for voluntary setbacks between each of the four new buildings of at least 20 feet, consistent with the side setback requirement for the district. Thus, adequate area for air, light, separation between neighbors and stormwater treatment is provided. The proposed density is also consistent with the surrounding area, which includes many smaller sized lots with homes located in relatively close proximity. (Exhibit E). Moreover, granting the requested variances will significantly improve the Property and surrounding area by removing two blighted, non-conforming commercial structures and replacing them with four brand new, homes where housing is sorely needed. The Property will be completely redeveloped, thus it follows that there is no reason to apply the strict requirements of the ordinance. This transitional location, located near and adjoining two densely development condominiums and across Sagamore Avenue from the SRB Zone is well suited for the proposed four building single-family development.

c. The proposed use is reasonable

If the use is permitted, it is deemed reasonable. Vigeant v. Hudson, 151 NH 747 (2005). The proposal is a residential use in a residential zone and thus is reasonable. Accordingly denial would result in an unnecessary hardship.

5. Substantial justice will be done by granting the variance.

If “there is no benefit to the public that would outweigh the hardship to the applicant” this factor is satisfied. Harborside Associates, L.P. v. Parade Residence Hotel, LLC, 162 N.H. 508 (2011). That is, “any loss to the [applicant] that is not outweighed by a gain to the general public is an injustice.” Malachy Glen, supra at 109.

“The right to use and enjoy one's property is a fundamental right protected by both the State and Federal Constitutions.” N.H. CONST. pt. I, arts. 2, 12; U.S. CONST. amends. V, XIV; Town of Chesterfield v. Brooks, 126 N.H. 64 (1985) at 68. Part I, Article 12 of the New Hampshire Constitution provides in part that “no part of a man's property shall be taken from him, or applied to public uses, without his own consent, or that of the representative body of the people.” Thus, our State Constitutional protections limit the police power of the State and its municipalities in their regulation of the use of property. L. Grossman & Sons, Inc. v. Town of Gilford, 118 N.H. 480, 482 (1978). “Property” in the constitutional sense has been interpreted to

mean not the tangible property itself, *but rather the right to possess, use, enjoy and dispose of it.* Burrows v. City of Keene, 121 N.H. 590, 597 (1981) (emphasis added). Sagamore is constitutionally entitled to the use of the lot as it sees fit subject only to the effect of the lot size and density requirements.

The Project: removes blighted buildings and a nonconforming commercial use; complies with all other dimensional requirements; maintains generous open space and vegetated buffers; provides additional screening with a robust planting plan, there will be no benefit to the public from denial and no harm to the public by granting the variances. Conversely, denial of the variances causes great harm to 635 Sagamore and its abutters by continuing the nonconforming commercial use of the Property. Accordingly, substantial justice is done by granting the variances.

V. CONCLUSION

For all of the reasons herein stated, Sagamore respectfully requests that the Portsmouth Zoning of Adjustment grant the requested variances.

Respectfully submitted,
635 Sagamore Development, LLC

By:

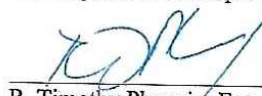

R. Timothy Phoenix, Esq.
Monica F. Kieser, Esq.

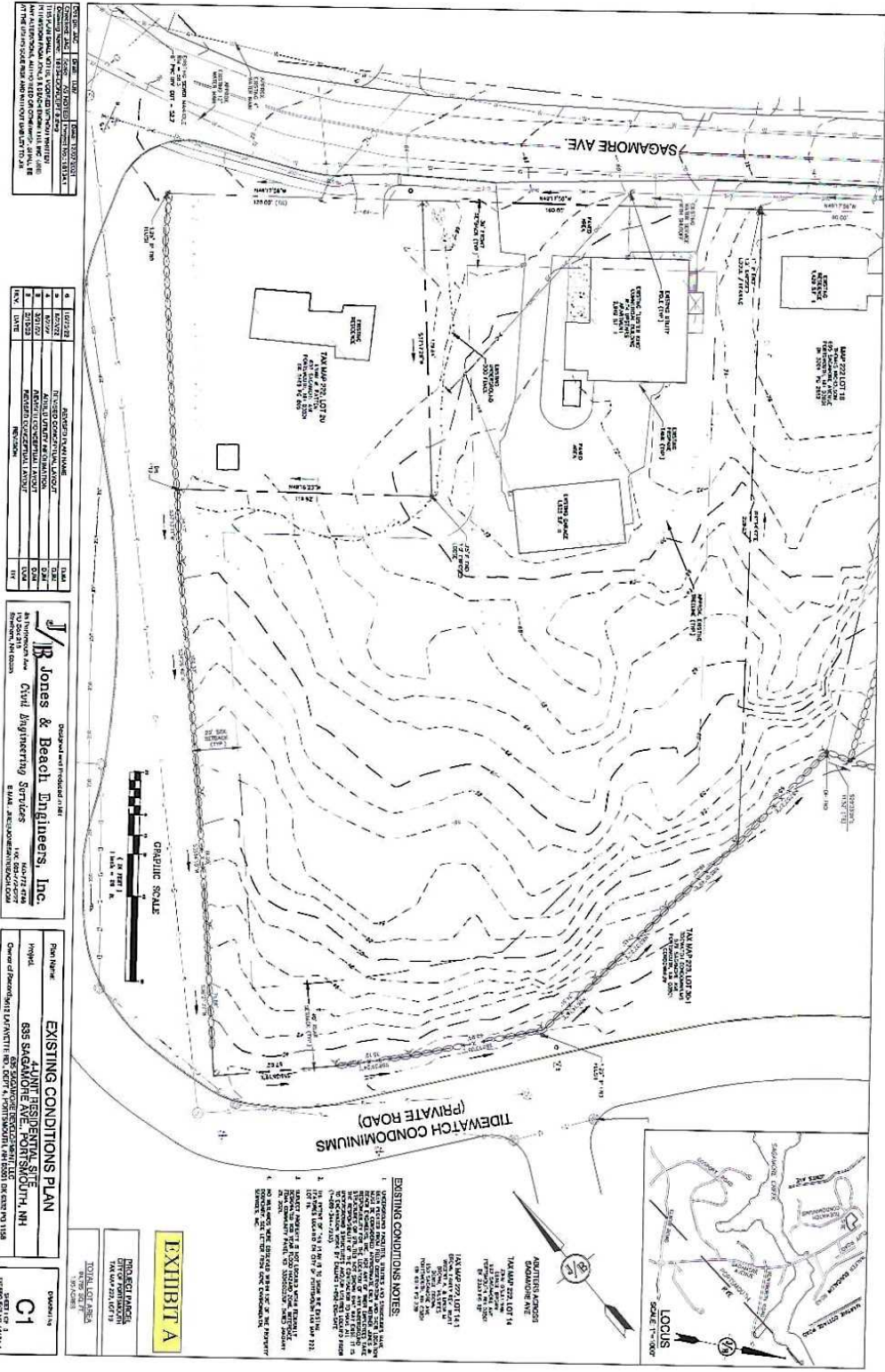

DATE	1/10/2018	BY	DAVID J. BROWN
PROJECT	EXISTING CONDITIONS PLAN		
CLIENT	TIDEWATCH CONDOMINIUMS		
ADDRESS	685 SAGAMORE AVE, TIDEWATCH, NH		
SCALE	AS SHOWN		

NO.	DATE	DESCRIPTION	BY
1	1/10/2018	EXISTING CONDITIONS PLAN	DAVID J. BROWN
2	1/10/2018	REVISIONS	DAVID J. BROWN

R Jones & Beach Engineers, Inc.
 Registered Professional Engineers
 685 SAGAMORE AVE, TIDEWATCH, NH 03097
 TEL: 603-888-1111 FAX: 603-888-1112
 WWW.RJBENGINEERS.COM

PROJECT NAME	EXISTING CONDITIONS PLAN
PROJECT NUMBER	685 SAGAMORE AVE, TIDEWATCH, NH
DATE	1/10/2018
SCALE	AS SHOWN

PROJECT NAME	EXISTING CONDITIONS PLAN
PROJECT NUMBER	685 SAGAMORE AVE, TIDEWATCH, NH
DATE	1/10/2018
SCALE	AS SHOWN

EXHIBIT A

EXISTING CONDITIONS NOTES:

1. ALL DIMENSIONS ARE IN FEET AND INCHES UNLESS OTHERWISE NOTED.
2. ALL DIMENSIONS ARE TO FACE UNLESS OTHERWISE NOTED.
3. ALL DIMENSIONS ARE TO CENTERLINE UNLESS OTHERWISE NOTED.
4. ALL DIMENSIONS ARE TO CENTERLINE UNLESS OTHERWISE NOTED.
5. ALL DIMENSIONS ARE TO CENTERLINE UNLESS OTHERWISE NOTED.
6. ALL DIMENSIONS ARE TO CENTERLINE UNLESS OTHERWISE NOTED.
7. ALL DIMENSIONS ARE TO CENTERLINE UNLESS OTHERWISE NOTED.
8. ALL DIMENSIONS ARE TO CENTERLINE UNLESS OTHERWISE NOTED.
9. ALL DIMENSIONS ARE TO CENTERLINE UNLESS OTHERWISE NOTED.
10. ALL DIMENSIONS ARE TO CENTERLINE UNLESS OTHERWISE NOTED.

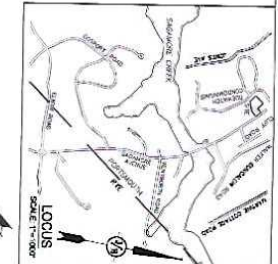

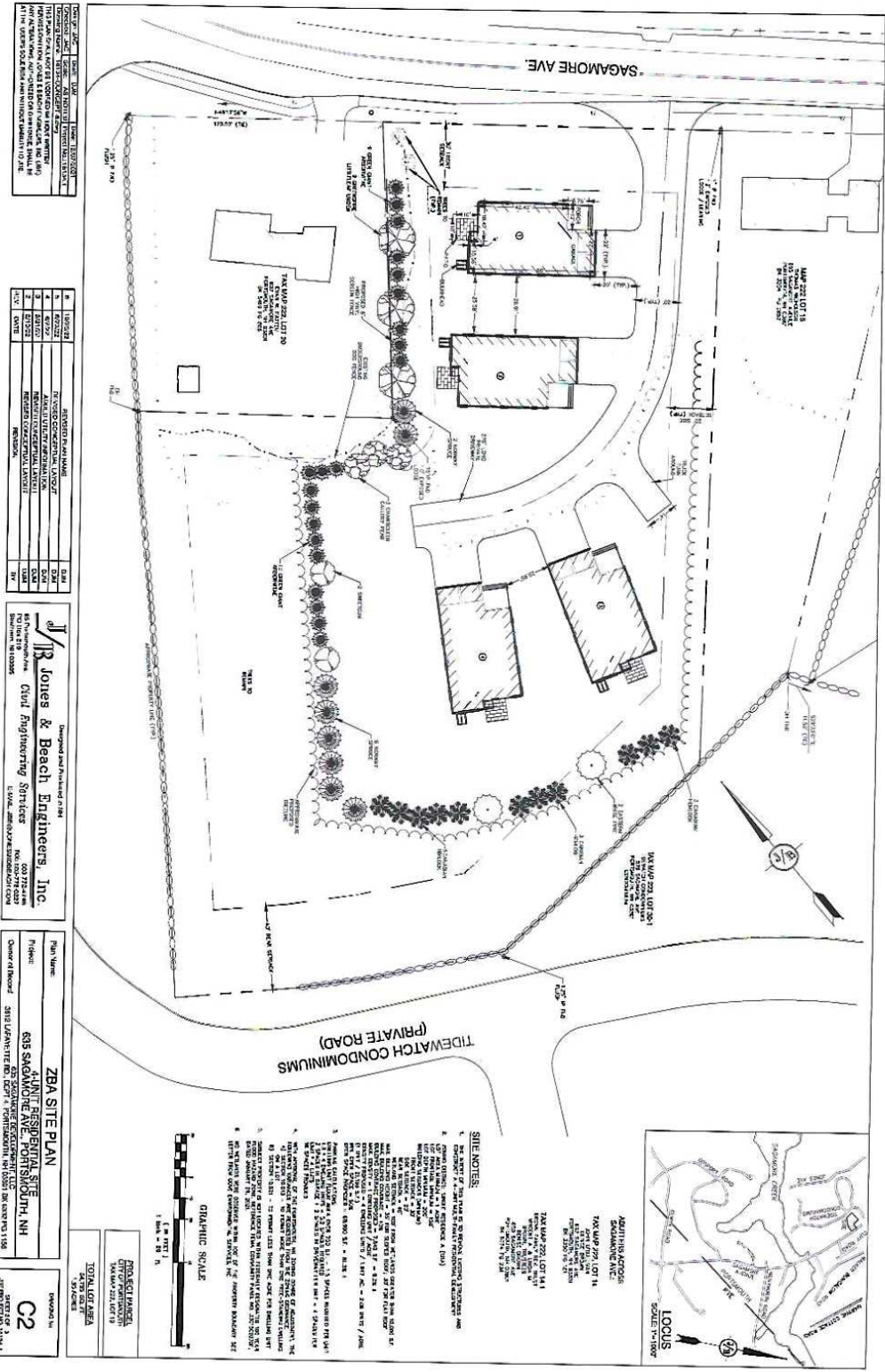

OWNER'S NOTICE
 THIS PLAN IS THE PROPERTY OF THE ENGINEER AND ARCHITECT. IT IS TO BE USED ONLY FOR THE PROJECT AND SITE SPECIFICALLY IDENTIFIED HEREON. ANY REUSE OR MODIFICATION OF THIS PLAN WITHOUT THE WRITTEN CONSENT OF THE ENGINEER AND ARCHITECT IS PROHIBITED. THE USER ASSUMES ALL LIABILITY FOR ANY ERRORS OR OMISSIONS IN THIS PLAN.

NO.	REVISION	DATE	BY	DESCRIPTION
1	ISSUED	05/20/22	JK	FINAL PLAN
2	REVISED	06/01/22	JK	REVISIONS TO PERMITTING
3	REVISED	06/15/22	JK	REVISIONS TO PERMITTING
4	REVISED	06/22/22	JK	REVISIONS TO PERMITTING
5	REVISED	06/29/22	JK	REVISIONS TO PERMITTING
6	REVISED	07/06/22	JK	REVISIONS TO PERMITTING
7	REVISED	07/13/22	JK	REVISIONS TO PERMITTING
8	REVISED	07/20/22	JK	REVISIONS TO PERMITTING
9	REVISED	07/27/22	JK	REVISIONS TO PERMITTING
10	REVISED	08/03/22	JK	REVISIONS TO PERMITTING
11	REVISED	08/10/22	JK	REVISIONS TO PERMITTING
12	REVISED	08/17/22	JK	REVISIONS TO PERMITTING
13	REVISED	08/24/22	JK	REVISIONS TO PERMITTING
14	REVISED	08/31/22	JK	REVISIONS TO PERMITTING
15	REVISED	09/07/22	JK	REVISIONS TO PERMITTING
16	REVISED	09/14/22	JK	REVISIONS TO PERMITTING
17	REVISED	09/21/22	JK	REVISIONS TO PERMITTING
18	REVISED	09/28/22	JK	REVISIONS TO PERMITTING
19	REVISED	10/05/22	JK	REVISIONS TO PERMITTING
20	REVISED	10/12/22	JK	REVISIONS TO PERMITTING
21	REVISED	10/19/22	JK	REVISIONS TO PERMITTING
22	REVISED	10/26/22	JK	REVISIONS TO PERMITTING
23	REVISED	11/02/22	JK	REVISIONS TO PERMITTING
24	REVISED	11/09/22	JK	REVISIONS TO PERMITTING
25	REVISED	11/16/22	JK	REVISIONS TO PERMITTING
26	REVISED	11/23/22	JK	REVISIONS TO PERMITTING
27	REVISED	11/30/22	JK	REVISIONS TO PERMITTING
28	REVISED	12/07/22	JK	REVISIONS TO PERMITTING
29	REVISED	12/14/22	JK	REVISIONS TO PERMITTING
30	REVISED	12/21/22	JK	REVISIONS TO PERMITTING
31	REVISED	12/28/22	JK	REVISIONS TO PERMITTING
32	REVISED	01/04/23	JK	REVISIONS TO PERMITTING
33	REVISED	01/11/23	JK	REVISIONS TO PERMITTING
34	REVISED	01/18/23	JK	REVISIONS TO PERMITTING
35	REVISED	01/25/23	JK	REVISIONS TO PERMITTING
36	REVISED	02/01/23	JK	REVISIONS TO PERMITTING
37	REVISED	02/08/23	JK	REVISIONS TO PERMITTING
38	REVISED	02/15/23	JK	REVISIONS TO PERMITTING
39	REVISED	02/22/23	JK	REVISIONS TO PERMITTING
40	REVISED	02/29/23	JK	REVISIONS TO PERMITTING
41	REVISED	03/06/23	JK	REVISIONS TO PERMITTING
42	REVISED	03/13/23	JK	REVISIONS TO PERMITTING
43	REVISED	03/20/23	JK	REVISIONS TO PERMITTING
44	REVISED	03/27/23	JK	REVISIONS TO PERMITTING
45	REVISED	04/03/23	JK	REVISIONS TO PERMITTING
46	REVISED	04/10/23	JK	REVISIONS TO PERMITTING
47	REVISED	04/17/23	JK	REVISIONS TO PERMITTING
48	REVISED	04/24/23	JK	REVISIONS TO PERMITTING
49	REVISED	05/01/23	JK	REVISIONS TO PERMITTING
50	REVISED	05/08/23	JK	REVISIONS TO PERMITTING
51	REVISED	05/15/23	JK	REVISIONS TO PERMITTING
52	REVISED	05/22/23	JK	REVISIONS TO PERMITTING
53	REVISED	05/29/23	JK	REVISIONS TO PERMITTING
54	REVISED	06/05/23	JK	REVISIONS TO PERMITTING
55	REVISED	06/12/23	JK	REVISIONS TO PERMITTING
56	REVISED	06/19/23	JK	REVISIONS TO PERMITTING
57	REVISED	06/26/23	JK	REVISIONS TO PERMITTING
58	REVISED	07/03/23	JK	REVISIONS TO PERMITTING
59	REVISED	07/10/23	JK	REVISIONS TO PERMITTING
60	REVISED	07/17/23	JK	REVISIONS TO PERMITTING
61	REVISED	07/24/23	JK	REVISIONS TO PERMITTING
62	REVISED	07/31/23	JK	REVISIONS TO PERMITTING
63	REVISED	08/07/23	JK	REVISIONS TO PERMITTING
64	REVISED	08/14/23	JK	REVISIONS TO PERMITTING
65	REVISED	08/21/23	JK	REVISIONS TO PERMITTING
66	REVISED	08/28/23	JK	REVISIONS TO PERMITTING
67	REVISED	09/04/23	JK	REVISIONS TO PERMITTING
68	REVISED	09/11/23	JK	REVISIONS TO PERMITTING
69	REVISED	09/18/23	JK	REVISIONS TO PERMITTING
70	REVISED	09/25/23	JK	REVISIONS TO PERMITTING
71	REVISED	10/02/23	JK	REVISIONS TO PERMITTING
72	REVISED	10/09/23	JK	REVISIONS TO PERMITTING
73	REVISED	10/16/23	JK	REVISIONS TO PERMITTING
74	REVISED	10/23/23	JK	REVISIONS TO PERMITTING
75	REVISED	10/30/23	JK	REVISIONS TO PERMITTING
76	REVISED	11/06/23	JK	REVISIONS TO PERMITTING
77	REVISED	11/13/23	JK	REVISIONS TO PERMITTING
78	REVISED	11/20/23	JK	REVISIONS TO PERMITTING
79	REVISED	11/27/23	JK	REVISIONS TO PERMITTING
80	REVISED	12/04/23	JK	REVISIONS TO PERMITTING
81	REVISED	12/11/23	JK	REVISIONS TO PERMITTING
82	REVISED	12/18/23	JK	REVISIONS TO PERMITTING
83	REVISED	12/25/23	JK	REVISIONS TO PERMITTING
84	REVISED	01/01/24	JK	REVISIONS TO PERMITTING
85	REVISED	01/08/24	JK	REVISIONS TO PERMITTING
86	REVISED	01/15/24	JK	REVISIONS TO PERMITTING
87	REVISED	01/22/24	JK	REVISIONS TO PERMITTING
88	REVISED	01/29/24	JK	REVISIONS TO PERMITTING
89	REVISED	02/05/24	JK	REVISIONS TO PERMITTING
90	REVISED	02/12/24	JK	REVISIONS TO PERMITTING
91	REVISED	02/19/24	JK	REVISIONS TO PERMITTING
92	REVISED	02/26/24	JK	REVISIONS TO PERMITTING
93	REVISED	03/05/24	JK	REVISIONS TO PERMITTING
94	REVISED	03/12/24	JK	REVISIONS TO PERMITTING
95	REVISED	03/19/24	JK	REVISIONS TO PERMITTING
96	REVISED	03/26/24	JK	REVISIONS TO PERMITTING
97	REVISED	04/02/24	JK	REVISIONS TO PERMITTING
98	REVISED	04/09/24	JK	REVISIONS TO PERMITTING
99	REVISED	04/16/24	JK	REVISIONS TO PERMITTING
100	REVISED	04/23/24	JK	REVISIONS TO PERMITTING

JR Jones & Beach Engineers, Inc.
 65 Elmwood Avenue
 Portsmouth, NH 03801
 Phone: 603-752-6233
 Fax: 603-752-6234
 Email: jrjones@jrbengr.com
 Website: www.jrbengr.com

ZBA SITE PLAN
 635 SAGAMORE AVENUE
 PORTSMOUTH, NH
 PROJECT NO. C2
 OWNER: JONES & BEACH ENGINEERS, INC.
 2810 LAURENTE RD, LOT 11, PORTSMOUTH, NH 03801
 DRAWING NO. 2304.1

PROJECT MANAGER
 JAMES W. JONES
 65 ELMWOOD AVENUE
 PORTSMOUTH, NH 03801
 PHONE: 603-752-6233
 FAX: 603-752-6234
 EMAIL: jrjones@jrbengr.com
 WEBSITE: www.jrbengr.com

GRAPHIC SCALE
 1" = 20'

TOTAL LOT AREA
 1,171.00 SQ. FT.

NOTE: THIS PLAN IS THE PROPERTY OF THE ENGINEER AND ARCHITECT. IT IS TO BE USED ONLY FOR THE PROJECT AND SITE SPECIFICALLY IDENTIFIED HEREON. ANY REUSE OR MODIFICATION OF THIS PLAN WITHOUT THE WRITTEN CONSENT OF THE ENGINEER AND ARCHITECT IS PROHIBITED. THE USER ASSUMES ALL LIABILITY FOR ANY ERRORS OR OMISSIONS IN THIS PLAN.

LOCUS
 SCALE 1" = 100'

ADJUTING ACROSS
 SAGAMORE AVENUE
 TAX MAP 222, LOT 1A
 TAX MAP 222, LOT 1B
 TAX MAP 222, LOT 1C
 TAX MAP 222, LOT 1D
 TAX MAP 222, LOT 1E
 TAX MAP 222, LOT 1F
 TAX MAP 222, LOT 1G
 TAX MAP 222, LOT 1H
 TAX MAP 222, LOT 1I
 TAX MAP 222, LOT 1J
 TAX MAP 222, LOT 1K
 TAX MAP 222, LOT 1L
 TAX MAP 222, LOT 1M
 TAX MAP 222, LOT 1N
 TAX MAP 222, LOT 1O
 TAX MAP 222, LOT 1P
 TAX MAP 222, LOT 1Q
 TAX MAP 222, LOT 1R
 TAX MAP 222, LOT 1S
 TAX MAP 222, LOT 1T
 TAX MAP 222, LOT 1U
 TAX MAP 222, LOT 1V
 TAX MAP 222, LOT 1W
 TAX MAP 222, LOT 1X
 TAX MAP 222, LOT 1Y
 TAX MAP 222, LOT 1Z

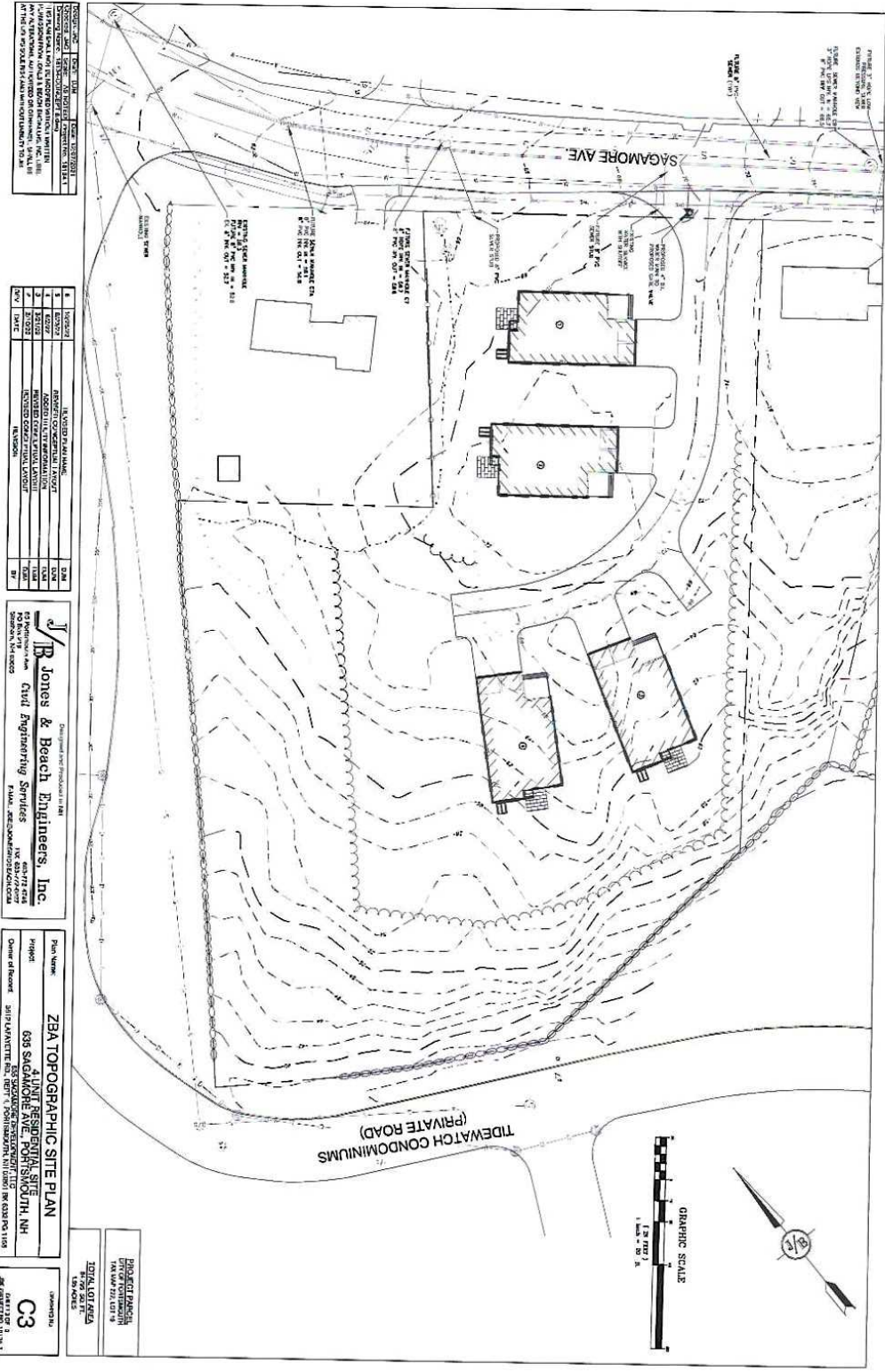

NO.	DATE	DESCRIPTION
1	10/1/01	PRELIMINARY
2	10/1/01	REVISIONS
3	10/1/01	REVISIONS
4	10/1/01	REVISIONS
5	10/1/01	REVISIONS
6	10/1/01	REVISIONS
7	10/1/01	REVISIONS
8	10/1/01	REVISIONS
9	10/1/01	REVISIONS
10	10/1/01	REVISIONS

NO.	DATE	DESCRIPTION
1	10/1/01	REVISIONS
2	10/1/01	REVISIONS
3	10/1/01	REVISIONS
4	10/1/01	REVISIONS
5	10/1/01	REVISIONS
6	10/1/01	REVISIONS
7	10/1/01	REVISIONS
8	10/1/01	REVISIONS
9	10/1/01	REVISIONS
10	10/1/01	REVISIONS

R Jones & Beach Engineers, Inc.
 Civil Engineering Services
 63 Merrimack Street, Suite 200
 Lowell, MA 01850
 Phone: 978.452.1234
 Fax: 978.452.1235
 Email: rjones@rjonesandbeach.com

ZBA TOPOGRAPHIC SITE PLAN
 PROJECT NO. 2017-001
 636 SAGAMORE AVE
 ROLLINGWOOD, NH
 03868

C3
 10/1/01

Sea Watch
419.126.v14 GL (1/27/2022)

©2011-2021 Art Form Architecture, Inc., all rights reserved. You may not build this design without purchasing a license, even if you make changes. This design may have geographic restrictions.



603-431-9559



Dear Builders and Home Buyers,

In addition to our Terms and Conditions (the "Terms"), please be aware of the following:

This design may not yet have Construction Drawings (as defined in the Terms), and is, therefore, only available as a Design Drawing (as defined in the Terms and together with Construction Drawings, "Drawings"). It is possible that during the conversion of a Design Drawing to a final Construction Drawing, changes may be necessary including, but not limited to, dimensional changes. Please see Plan Data Explained on www.ArtformHomePlans.com to understand room sizes, dimensions and other data provided. We are not responsible for typographical errors.

Artform Home Plans ("Artform") requires that our Drawings be built substantially as designed. Artform will not be obligated by or liable for use of this design with markups as part of any builder agreement. While we attempt to accommodate where possible and reasonable, and where the changes do not denigrate our design, any and all changes to Drawings must be approved in writing by Artform. It is recommended that you have your Drawing updated by Artform prior to attaching any Drawing to any builder agreement. Artform shall not be responsible for the misuse of or unauthorized alterations to any of its Drawings.

Facade Changes:

- To maintain design integrity, we pay particular attention to features on the front facade, including but not limited to door surrounds, window casings, finished porch column sizes, and roof friezes. While we may allow builders to add their own flare to aesthetic elements, we don't allow our designs to be stripped of critical details. Any such alterations require the express written consent of Artform.
- Increasing ceiling heights usually requires adjustments to window sizes and other exterior elements.

Floor plan layout and/or Structural Changes:

- Structural changes always require the express written consent of Artform
- If you wish to move or remove walls or structural elements (such as removal of posts, increases in house size, ceiling height changes, addition of dormers, etc), please do not assume it can be done without other additional changes (even if the builder or lumber yard says you can).

EXHIBIT B

Sea Watch
419.126.v14 GL (1/27/2022)

©2011-2021 Art Form Architecture, Inc. all rights reserved. You may not build this design without purchasing a license, even if you make changes. This design may have geographic restrictions.

 **Artform Home Plans**
603-431-9559



Sea Watch
 419.126.v14 GL (1/27/2022)

©2011-2021 Art Form Architecture, Inc., all rights reserved. You may not build this design without purchasing a license, even if you make changes. This design may have geographic restrictions.

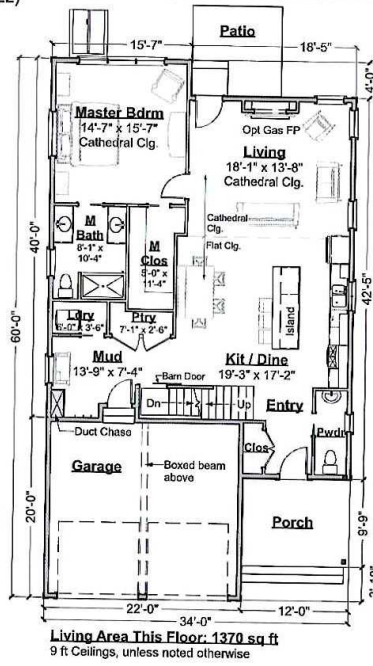

First Floor Plan
 Scale: 3/32" = 1'-0"

Sea Watch
 419.126.V14 GL (1/27/2022)

©2011-2021 Art Form Architecture, Inc., all rights reserved. You may not build this design without purchasing a license, even if you make changes. This design may have geographic restrictions.



Living Area This Floor: 979 sq ft
 8 ft Ceilings, unless noted otherwise

603-431-9559

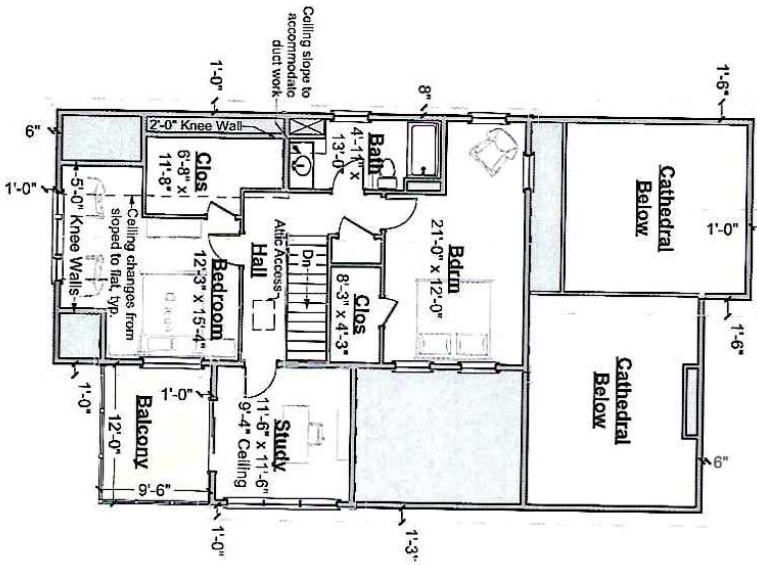

Second Floor Plan
 Scale: 3/32" = 1'-0"

Sea Watch
419.126.v14 GL (1/27/2022)

©2011-2021 Art Form Architecture, Inc., all rights reserved. You may not build this design without purchasing a license, even if you make changes. This design may have geographic restrictions.

 **Artform Home Plans**
603-431-9589

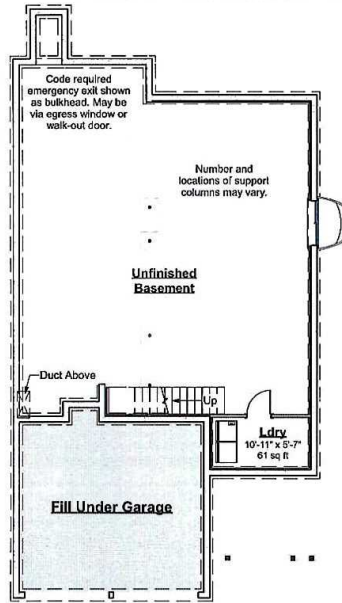

Foundation Plan
Scale: 3/32" = 1'-0"

Sea Watch
419.126.v14 GL (1/27/2022)

©2011-2021 Art Form Architecture, Inc., all rights reserved. You may not build this design without purchasing a license, even if you make changes. This design may have geographic restrictions.

Artform Home Plans
603-431-8559



Front Elevation
Scale: 1/8" = 1'-0"

Sea Watch
419.126.v14 GL (1/27/2022)

©2011-2021 Art Form Architecture, Inc., all rights reserved. You may not build this design without purchasing a license, even if you make changes. This design may have geographic restrictions.

Artform Home Plans
603-431-9559



Right Elevation
Scale: 1/8" = 1'-0"

Sea Watch
419.126.v14 GL (1/27/2022)

©2011-2021 Art Form Architecture, Inc., all rights reserved. You may not build this design without purchasing a license, even if you make changes. This design may have geographic restrictions.

Artform Home Plans
603-431-8559



Rear Elevation
Scale: 1/8" = 1'-0"

Sea Watch
419.126.v14 GL (1/27/2022)

©2011-2021 Art Form Architecture, Inc., all rights reserved. You may not build this design without purchasing a license, even if you make changes. This design may have geographic restrictions.

 **Artform Home Plans**
603-431-9559



Left Elevation
Scale: 1/8" = 1'-0"

EXHIBIT C



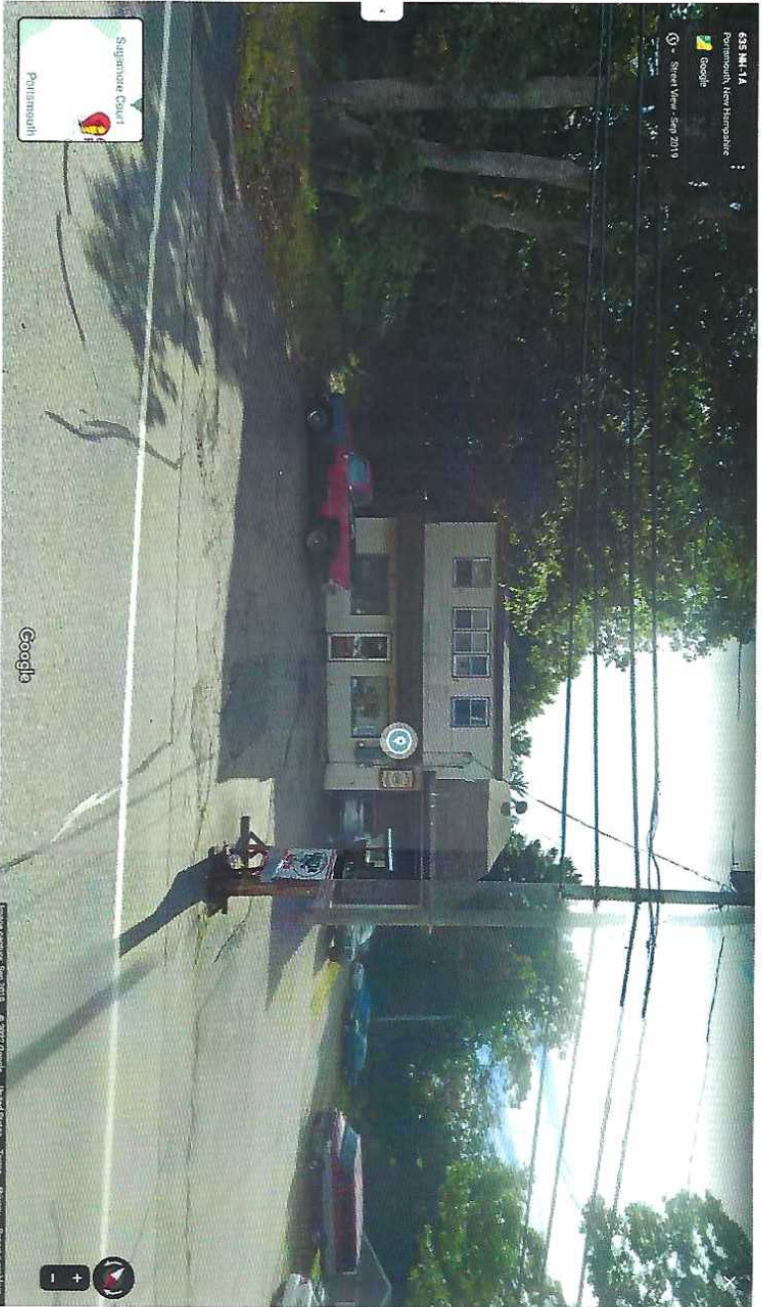

Front View of Property (Sagamore Ave)



Front View of Property



Front View of Property



Side View of Property



View of Service Garage and Shed



Rear View of Property

Sea Watch
419.126.v14 GL (1/27/2022)

©2011-2021 Art Form Architecture, Inc., all rights reserved. You may not build this design without purchasing a license, even if you make changes. This design may have geographic restrictions.

Artform Home Plans
603-431-9559



Interior Views

635 SAGAMORE AVE

Location 635 SAGAMORE AVE

Mblu 0222/ 0019/ 0000/ /

Acct# 35416

Owner 635 SAGAMORE DEVELOPMENT LLC

PBN

Assessment \$682,800

Appraisal \$682,800

PID 35416

Building Count 2

Current Value

Appraisal			
Valuation Year	Improvements	Land	Total
2020	\$407,600	\$275,200	\$682,800

Assessment			
Valuation Year	Improvements	Land	Total
2020	\$407,600	\$275,200	\$682,800

Owner of Record

Owner 635 SAGAMORE DEVELOPMENT LLC
Co-Owner
Address 3612 LAFAYETTE RD DEPT 4
 PORTSMOUTH, NH 03801

Sale Price \$387,133
Certificate
Book & Page 6332/1158
Sale Date 09/24/2021

Ownership History

Owner	Sale Price	Certificate	Book & Page	Sale Date
635 SAGAMORE DEVELOPMENT LLC	\$387,133		6332/1158	09/24/2021
HINES FAMILY REVO TRUST	\$0		4885/1538	02/11/2008

Building Information

Building 1 : Section 1

Year Built: 1950
Living Area: 4,477

Replacement Cost: \$513,721
Building Percent Good: 54
Replacement Cost
Less Depreciation: \$277,400

Building Attributes	
Field	Description
Style:	Retail/Apartment
Model	Commercial
Grade	C
Stories:	2
Occupancy	3.00
Residential Units	
Exterior Wall 1	Vinyl Siding
Exterior Wall 2	Pre-Fab Wood
Roof Structure	Gable/Hip
Roof Cover	Asph/F Gls/Cmp
Interior Wall 1	Drywall/Sheet
Interior Wall 2	
Interior Floor 1	Inlaid Sht Gds
Interior Floor 2	Carpet
Heating Fuel	Oil
Heating Type	Hot Water
AC Type	Unit/AC
Bldg Use	PRI COMM
Total Rooms	
Total Bedrms	
Total Baths	
Kitchen Grd	
Heat/AC	NONE
Frame Type	WOOD FRAME
Baths/Plumbing	AVERAGE
Ceiling/Wall	CEIL & WALLS
Rooms/Prtns	AVERAGE
Wall Height	10.00
% Corn Wall	
1st Floor Use:	
Class	

Building 2 : Section 1

Year Built: 2000
Living Area: 1,650
Replacement Cost: \$153,450

Building Photo

 Building Photo
 (http://images.vgsi.com/photos2/PortsmouthNHPhotos//0033/DSC01732_)

Building Layout

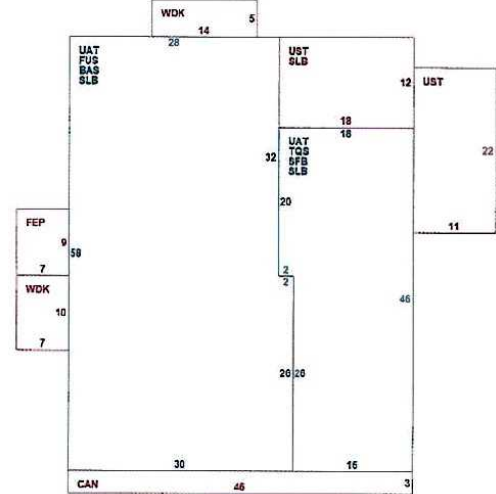

(ParcelSketch.ashx?pid=35416&bid=35416)

Building Sub-Areas (sq ft)		Legend	
Code	Description	Gross Area	Living Area
BAS	First Floor	1,676	1,676
FUS	Upper Story, Finished	1,676	1,676
TQS	Three Quarter Story	776	582
SFB	Base, Semi-Finished	776	543
CAN	Canopy	138	0
FEP	Porch, Enclosed	63	0
SLB	Slab	2,668	0
UAT	Attic	2,452	0
UST	Utility, Storage, Unfinished	458	0
WDK	Deck, Wood	140	0
		10,823	4,477

Building Percent Good: 84
Replacement Cost
Less Depreciation: \$128,900

Building Attributes : Bldg 2 of 2	
Field	Description
Style:	Service Shop
Model	Commercial
Grade	C
Stories:	1
Occupancy	1.00
Residential Units	
Exterior Wall 1	Vinyl Siding
Exterior Wall 2	
Roof Structure	Gable/Hip
Roof Cover	Asph/F Gls/Cmp
Interior Wall 1	Drywall/Sheet
Interior Wall 2	
Interior Floor 1	Concr-Finished
Interior Floor 2	Carpet
Heating Fuel	Oil
Heating Type	Hot Water
AC Type	None
Bldg Use	AUTO S S&S
Total Rooms	
Total Bedrms	
Total Baths	
Kitchen Grd	
Heat/AC	NONE
Frame Type	WOOD FRAME
Baths/Plumbing	AVERAGE
Ceiling/Wall	CEIL & WALLS
Rooms/Prtns	AVERAGE
Wall Height	12.00
% Conn Wall	
1st Floor Use:	
Class	

Building Photo

 Building Photo
 (http://images.vgsi.com/photos2/PortsmouthNHPhotos///0033/DSC01731_)

Building Layout

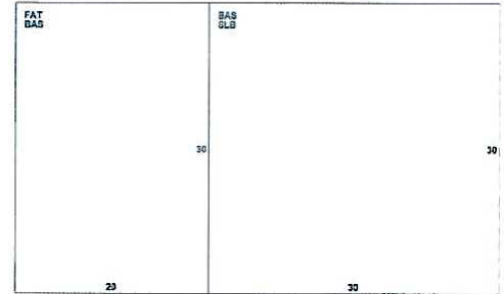

(ParcelSketch.aspx?pid=35416&bid=40140)

Building Sub-Areas (sq ft)		Legend	
Code	Description	Gross Area	Living Area
BAS	First Floor	1,500	1,500
FAT	Attic	600	150
SLB	Slab	900	0
		3,000	1,650

Extra Features

Extra Features		Legend

No Data for Extra Features

Land

Land Use

Use Code 0310
 Description PRI COMM
 Zone SRA
 Neighborhood 306
 Alt Land Appr No
 Category

Land Line Valuation

Size (Acres) 1.93
 Frontage
 Depth
 Assessed Value \$275,200
 Appraised Value \$275,200

Outbuildings

Outbuildings						Legend
Code	Description	Sub Code	Sub Description	Size	Value	Bldg #
PAV1	PAVING-ASPHALT			1344.00 S.F.	\$1,200	1
SHD1	SHED FRAME			96.00 S.F.	\$100	1

Valuation History

Appraisal			
Valuation Year	Improvements	Land	Total
2020	\$418,400	\$275,200	\$693,600
2019	\$418,400	\$275,200	\$693,600
2018	\$391,100	\$254,800	\$645,900

Assessment			
Valuation Year	Improvements	Land	Total
2020	\$418,400	\$275,200	\$693,600
2019	\$418,400	\$275,200	\$693,600
2018	\$391,100	\$254,800	\$645,900

(c) 2022 Vision Government Solutions, Inc. All rights reserved.



WHITE APPRAISAL

REAL ESTATE APPRAISING & CONSULTING

Brian W. White, MAI, SRA



CERTIFICATE

I do hereby certify that, except as otherwise noted in this report:

1. the statements of fact contained in this report are true and correct;
2. the reported analyses, opinions and conclusions are limited only by the reported assumptions and limiting conditions and are my personal, unbiased professional analyses, opinions and conclusions;
3. I have no present or prospective interest in the property which is the subject of this report and I have no personal interest or bias with respect to the parties involved;
4. I have no bias with respect to the property that is the subject of this report or to the parties involved with this assignment;
5. my engagement in this assignment was not contingent upon developing or reporting predetermined results;
6. my compensation for completing this assignment is not contingent upon the development or reporting of a predetermined value or direction in value that favors the cause of the client, the amount of the value opinion, the attainment of a stipulated result, or the occurrence of a subsequent event directly related to the intended use of this appraisal;
7. my analysis, opinions, and conclusions, were developed, and this report has been prepared in conformity with the Uniform Standards of Professional Appraisal Practice;
8. Brian W. White, MAI, SRA a made a personal inspection of the property that is the subject of this report;
9. no one has provided significant real property appraisal assistance to the persons signing this certification;
10. I have prepared no services, as an appraiser or in any other capacity, regarding the property that is the subject of this report within the three-year period immediately preceding acceptance of this assignment;
11. the reported analyses, opinions, and conclusions were developed, and this report has been prepared, in conformity with the Code of Professional Ethics & Standards of Professional Appraisal Practice of the Appraisal Institute;
12. the use of this report is subject to the requirements of the Appraisal Institute relating to review by its duly authorized representatives;
13. as of the date of this report, Brian W. White, MAI, SRA, has completed the continuing education program for Designated Members of the Appraisal Institute.

Respectively submitted,

Brian W. White, MAI, SRA NHC#-52

130 VARNEY ROAD • DOVER, NEW HAMPSHIRE 03820 • BRIANWMAI@AOL.COM • (603) 742-5925

Qualifications of the Appraiser

Brian W. White, MAI, SRA

Professional Designations:

Member, Appraisal Institute (*MAI*) – Awarded by the Appraisal Institute. MAI #9104
Senior Residential Appraiser (*SRA*)

Employment:

1989 to Present White Appraisal – Dover, NH
President – Senior Appraiser
Owner of White Appraisal, a commercial and residential
real estate appraisal firm. Complete appraisals on all
types of commercial and residential properties.
Consulting.

1988 Finlay Appraisal Services – Portsmouth, NH
Senior Vice President/Chief Operations Officer
Oversaw the operation of four appraisal offices. Completed commercial
and residential appraisals on all types of properties.

1985 Finlay Appraisal Services – Portsmouth, NH
and Appraisal Services Manager – South Portland, ME.
Completed commercial and residential appraisals on all types of
properties.

Education:

Mitchell College
Associate of Arts, Liberal Studies, 1979

University of Southern Maine
Bachelors of Science, Business Admin., 1984
Bus 022 Real Estate Law
Bus 023 Real Estate Practice
Bus 025 Real Estate Valuation

American Institute of Real Estate Appraisers
1A-1 Real Estate Appraisal Principles, 1985
1A-2 Basic Valuation Procedures, 1985
1B-A Cap. Theory and Technique (A), 1985
1B-B Cap. Theory and Technique (B), 1985
2-3 Standards of Pro. Practice, 1985
Exam #7 Industrial Valuation, 1986

Society of Real Estate Appraisers
101 Intro. To Appraising Real Property, 1986
102 Applied Residential Property Val., 1987
201 Prin. Of Income Property Appraising, 1985
202 Applied Income Property Valuation, 1985

Education (Continued):

USPAP Update- 2017
USPAP Update- 2019
Business Practices & Ethics- 2021
USPAP 2022/2023 Update- 2021

Recent Seminars:

Current Use - 2018
Real Estate Damages Overview - 2018
Understanding and Using Public Data - 2018
Appraising Energy Efficient Residential Properties – 2018
Commercial Real Estate Roundtable – 2019
Appraiser Essentials with CRS and Green Fields – 2019
Land Development & Residential Building Costs – 2019
Myths in Appraiser Liability – 2019
Appraising in Uncertain Times – 2019
Market Trends in NH Real Estate – 2020
Appraising Commercial Properties during a Pandemic – 2020
Defining the Appraisal Problem: Sleuthing for the Approaches to Value- 2021
Forest Valuation- 2021
Appraiser Essentials Paragon MLS- 2021
Residential Building Systems- 2021
2021-2022 NH Market Insights- 2021
Implications for Appraisers of Conservation Easement Appraisals- 2022
NH's Housing Market & Covid: What a Long, Strange Road It's Been!- 2022

Appointments:

Board of Directors – New Hampshire Chapter of the Appraisal Institute - 1991 to 1993; 2000 to 2010 and 2015-2018
Vice President - New Hampshire Chapter of the Appraisal Institute – 2011-2012 & 2019
President – New Hampshire Chapter of the Appraisal Institute – 2013 & 2014

Experience:

Review Chairperson – New Hampshire Chapter of the Appraisal Institute – 1994 to 2010

Licenses:

N.H. Certified General Appraiser #NHCG -52, Expires 4/30/2023

Partial List of Clients:

Banks:

Androscoggin Bank
Granite Bank
Federal Savings Bank
Sovereign Bank
Eastern Bank
Century Bank
TD Bank
Kennebunk Savings Bank
Northeast Federal Credit Union
Profile Bank
Peoples United Bank
Key Bank
Optima Bank and Trust
Provident Bank

Attorneys:

John Colliander
Karyn Forbes
Michael Donahue
Richard Krans
Simone Massy
Samuel Reid
Daniel Schwartz
Robert Shaines
William Shaheen
Steve Soloman
Gerald Giles
Ralph Woodman
Gayle Braley
Fred Forman

Others:

City of Dover
Town of Durham
University of New Hampshire
Wentworth-Douglass
The Homemakers
Strafford Health Alliance
Goss International
Chad Kageleiry
Gary Levy
Stan Robbins
Daniel Philbrick
Keith Frizzell
Chuck Cressy
John Proulx

State of New Hampshire



Real Estate Appraisers Board

Authorized as
Certified General Appraiser

Issued To

BRIAN W WHITE

License Number: NHCG-52

Issue Date: 01/01/1992
Expiration Date: 04/30/2025