

JONES & BEACH ENGINEERS INC.

85 Portsmouth Avenue, PO Box 219, Stratham, NH 03885
603.772.4746 - JonesandBeach.com

April 19, 2024

Portsmouth Technical Advisory Committee
Attn: Board Members
1 Junkins Avenue, Suite 3rd Floor
Portsmouth, NH 03801

RE: Response Letter - LU-22-209
635 Sagamore Ave, Portsmouth, NH
Tax Map 222, Lot 19
JBE Project No. 18134.1

Dear Board Members,

We are in receipt of comments from the Technical Advisory Committee, provided by Stefanie Casella, City Planner, dated March 29, 2024. Review comments are listed below with our responses in bold.

- 1. The city is finalizing roadway improvement design. City to work with applicant on CB location in relation to new sidewalk location.*

RESPONSE: No response necessary at this time.
- 2. Sight lines at driveway are slightly shorter than required based on existing roadway profile. Sight lines will need to be rechecked once the City's roadway design is finalized. Possible mitigation measures needed if sight lines remain below minimums.*

RESPONSE: Prior to the initial TAC submission, we had discussed the sight lines with Eric Eby. It was understood that we were under the minimum stopping sight distance and that mitigation measures would be necessary, such as a "blind driveway" warning sight or 25 MPH posted speed limit over the crest of the hill to the south as Mr. Eby suggested via email on February 23, 2024.
- 3. Water work needs to be out of right of way prior to Sagamore road work. This includes extending new water to property and cut & cap of the previous water.*

RESPONSE: A water line stub will be extended to the right of way line prior to the Sagamore Ave road work.
- 4. Move water to driveway location.*

RESPONSE: Water has been moved to the driveway location.
- 5. Remove label for 4" water main on far side of Sagamore Road. 4" water main has been abandoned.*

RESPONSE: The word "Abandoned" has been added to the label for the 4" water main on Sheets C1 and C4.

6. *Are there plans to extend gas to the site? Stub gas main label on overhead wires south of site. Sheet C4 Utility Plan.*

RESPONSE: We are not planning to extend the gas main to the site. The units will have propane tanks as shown on Sheet C4. The “stub gas main” label was a holdover from when natural gas service was being considered and has been removed.

7. *How will this site deal with trash pickup?*

RESPONSE: The owner of each unit shall store trash in their garage. Trash will be picked up by a private hauler. See Note #21 on Sheet C2.

8. *Remove stop bar and stop sign leaving site. This is not a road it is a driveway.*

RESPONSE: The stop sign and stop bar have been removed from the plan.

9. *Change SMH2 inlet to a drop manhole connection to flatten out sewer run.*

RESPONSE: The sewer layout has been revised so this is no longer necessary. Previously, a drop inlet would have been helpful in order to flatten the sewer run and reduce the depth of the trench, but we have rearranged the sewer layout to eliminate the drainage crossing that made this sewer manhole necessary in the first place. Therefore, we now have only three sewer manholes proposed rather than four and we are placing a flatter 3.2% run between SMH 1 and SMH 2, which more nearly follows proposed grade than what was previously proposed and requires a shallower trench.

10. *Drainage Concerns:*

- *The drainage study needs to be revisited. We do not agree that these are type B soils due to the shallow ledge. The study also uses very long time of concentration sheet flow lengths that are inaccurate due to the steepness and type of terrain. Because of this, we believe that the runoff generation calculations are not accurate.*

RESPONSE: See attached letter from the soil scientist. The soils on site are represented as HSG B because Chatfield, which is classified as HSG B, is the dominant soil type within the Chatfield-Hollis-Canton soil complex that makes up most of the subject parcel. Modelling the site as HSG B rather than C or D is a conservative approach. The addition of impervious surface causes more of a change to the curve number (CN) with the site represented as HSG B than with the site represented as HSG C or D and therefore this provides a safety factor for the requirement to reduce off-site peak flows to below the existing.

Tc paths are taken from the most hydraulically distant point and this is what we did. Each modelled Tc path is broken into several different sections to analyze each slope and land cover segment separately. We have double checked to make sure that we are modelling the correct slopes and land covers. Furthermore, modelling a long Tc path in the existing conditions is a conservative approach as this increases the difference in peak flows that needs to be attenuated.

- *We also believe that the applicant should have added the 3S and 4S hydrographs together in both the pre and post conditions because they combine along the Tidewatch road about 130' past AP3. There is evidence that there is in fact historic flooding or at a minimum, poor drainage conditions, in this location at the base of the hill adjacent to the Tidewatch road in the predevelopment condition so we are suspect of the calculations.*

RESPONSE: Subcatchments 3S and 4S need to be separate. 3S represents the runoff that reaches the ditch along the Tidewatch Condominium road while 4S represents the runoff that directly enters the catch basin adjacent to the Tidewatch Condominium mailbox structure, modelled as AP3. However, we agree that both subcatchments ultimately drain toward one analysis point; therefore, we have removed AP4 from the analysis and AP3 represents the catch basin on the Tidewatch Condominium property that the runoff from 3S and 4S ultimately drains into in the existing condition. 3S and 4S both ultimately drain toward Analysis Point 3, but 3S drains toward a shallow drainage ditch on the Tidewatch property before reaching AP3 while 4S drains directly over land to the analysis point.

- *We also feel that perhaps the engineer should explore moving the outlet of Bioretention Pond #1 southeast so that the flow leaving the pond is closest to its ultimate discharge point but this must be vetted during the calculations.*

RESPONSE: We are no longer proposing a bioretention pond where Pond #1 was previously proposed. All site runoff is now directed toward a single pond, now referred to as Bioretention Pond #1, where Bioretention Pond #2 was previously. The area where this pond is proposed is the only part of the site with enough depth to ledge to allow infiltration according to the results of test pits 8 and 10. Small infiltration practices are also proposed adjacent to units 3&4 where ledge is shallower, but we are providing enough fill at these locations to facilitate infiltration. The discharge from this pond will be directed over land toward the existing drainage ditch on the Tidewatch Condominium property, from where it will be directed to the ultimate discharge point (Analysis Point 3). Having the discharge flow through the ditch first rather than being outletted directly on to the Tidewatch property downstream of the ditch will help to better maintain or improve upon existing hydrologic patterns and prevent an increase in flooding at the ultimate discharge point. The swale has been modelled to ensure that an increase in runoff is not proposed to flow to it and the peak elevation stays the same or decreases.

- *An off-site drainage improvement on Tidewatch property may be necessary to shed the stormwater via a new culvert under the private Tidewatch road and into one of the Tidewatch wetland areas directly as the flow from this development seems to be directed toward a single catch basin located near Tidewatch's mailbox structure.*

RESPONSE: We are not opposed to this, however we would need permission from Tidewatch and would need more survey detail as well. If a culvert is added it should be cored into the catch basin that the runoff from the subject parcel is draining toward in the existing condition rather than across the street into the wetland, in order to mimic existing drainage patterns and not increase peak rates of runoff upon the wetland.

- *We are therefore recommending a third-party Engineer review the design and the stormwater report.*

RESPONSE: John Chagnon of Haley Ward is already reviewing the design on behalf of Tidewatch Condominium, however we understand that the City will also be sending the plans and drainage report to their own review consultant.

11. *Please demonstrate how you can reduce flow entering into AP3 to meet or be reduced by pre-development numbers [Section 6.1 (d) and Section 7.6 in Site Plan Review Regs]. While there is ledge across the site, please provide a low impact development method for reducing flow in this area as infiltration does not appear to be viable.*

RESPONSE: The peak flow was already being reduced with the previous design, however the volume of runoff directed toward Analysis Point 3 was being slightly increased as we acknowledged in our drainage report due to the lack of infiltration at the former pond location. With the increased infiltration capacity in the revised design, post-development runoff volumes will be less than pre-development runoff volumes toward all analysis points during the 2-, 10-, 25-, and 50-Year 24 Hour storms.

12. *Please demonstrate how this project will conserve stormwater on site and practice low impact development stormwater practices (drip edges, rain barrels, stormwater filtration with vegetation, etc.). [Section 6.3, Section 6.6 and Section 7.1]*

RESPONSE: All of the stormwater management devices that we are proposing are Low Impact Development (LID) devices. Rain gardens are listed as an example of an LID device in Section 7.1 of the Site Plan Review Regulations and pre-treatment is achieved through the use of deep sump catch basins rather than a sediment forebay. Where practicable, roof runoff is being captured and directly infiltrated through the use of stone drip edges and a permeable paver patio. These devices are only being proposed where the basement slab will be above the groundwater table.

13. *Please provide a green statement that addresses the sustainable and energy efficient practices that you intend to pursue in this development. [Section 2.5.3 (b)]*

RESPONSE: A green building statement is included with this submission.

14. *Please update landscaping plans to acknowledge planting requirements [Section 6.2.2 (d-f), and Section 6.4] and to demonstrate adherence to Section 6.3 in the Site Plan Review Regulations.*

RESPONSE: The landscape designer has denoted on the planting schedule on Sheet L2 which plants are tolerant of urban conditions and also added Notes 19 and 20 to this sheet stipulating the requirements that need to be followed.

15. *Please include in stormwater management operations and maintenance manual that an annual report will be submitted to the City of Portsmouth Department of Public Works.*

RESPONSE: This requirement has been added to Section A.1 of the O&M Manual.

16. *Please indicate if, and/or where, snow storage will be located on site. If located on site, please demonstrate compliance with Section 7.6.1 (10).*

RESPONSE: Snow storage is shown on Sheet C2. The snow storage locations have been revised so that it is only shown in areas where snowmelt will drain toward a treatment BMP in accordance with the cited requirement.

17. Please provide a condo plan.

RESPONSE: A draft condominium site plan has been added as Sheet CS1 of the plan set.

18. How high are the buildings from the existing grade vs the proposed grade?

RESPONSE: See below table. In accordance with the definition of “building height” provided in Article 15 of the Zoning Ordinance, we measured the height of each building from average existing grade or average finished grade, whichever is lower, to the midpoint between the level of the roof eaves and the highest point of the roof. Based on this definition, all units are under the maximum height of 35’ per the Zoning Regulations.

	Unit 1	Unit 2	Unit 3	Unit 4
Finished Floor elevation	73.5	74.0	74.5	75.0
FF to midpoint of ridge (ft.)	27.67	27.67	23.89	23.89
Ridge midpoint elevation	101.17	101.67	98.39	98.89
Average existing grade elevation	71.0	72.0	65.5	66.0
Average finished grade elevation	72.0	73.0	69.0	68.0
Building Height (ft.) based on lower of average existing and proposed grade	30.17	29.67	32.89	32.89

Included with this response letter are the following:

1. One (1) Full Size Plan Set (Folded).
2. One (1) Drainage Analysis.
3. One (1) Stormwater Operations & Maintenance Manual.
4. One (1) Green Building Statement.
5. Letter from Soil Scientist.

If you have any questions or need any additional information, please feel free to contact our office. Thank you very much for your time.

Very truly yours,

JONES & BEACH ENGINEERS, INC.

Joseph Coronati

Joseph A. Coronati

Vice President

cc: Michael Garrepy (via email)

Christopher Ward (via email)

John Chagnon, P.E., Haley Hard (reviewer on behalf of Tidewatch Condominium, via email and U.S. Mail.)

Eric Weinrieb, Altus Engineering (via email & Hard Copy Delivered)



Architecture | Planning
22 Jady Hill Avenue
Exeter, NH 03833
207.347.1504

City of Portsmouth
Planning Department
Attn: Peter Stith, Principal Planner
1 Junkins Ave, 3rd Floor
Portsmouth, NH 03801

April 1, 2024

Dear Mr. Stith,

The residential units proposed for the project at 635 Sagamore Avenue are being designed to meet or exceed the applicable green building standards as set forth in the 2018 set of Codes adopted by the State of New Hampshire, along with associated amendments codified by the City of Portsmouth.

In an effort promote the buildings' efficiency, longevity, and health of their occupants, close attention shall be given to the following building categories:

- Tight building enclosures
 - o Watertightness (though moisture barriers)
 - o Vapor permeability
 - o Airtightness
 - o Aire quality, environmental controls, and whole-house ventilation
- Thermal control for reduced energy usage
 - o Enhanced envelope assembly R-Values and window/door U-Values
 - o Solar Heat Gain Coefficient and orientation of windows and doors
- High-efficiency water heating & HVAC equipment
- ENERGY STAR appliances
- High-efficiency lighting
- Low-flow water fixtures

Assemblies and systems for the proposed residences shall be specified during the Building Permit Application phase.

Thank you,

A handwritten signature in black ink, appearing to read "Margaret Randolph", written over a light blue horizontal line.

Margaret Randolph, RA, NCARB, AIA, LEED AP ND

635 Sagamore Avenue (LU-24-34) Staff Comments for TAC Meeting

“not type B soils due to shallow ledge”

The dominant soil unit mapped on the site was 41- a complex of soil types so intermixed that no one soil can be separated into a single consociation or soil type. The complex is named Chatfield-Hollis-Rock Outcrop. Based upon the test pits (3 Hollis, 6 Chatfield (Chatfield well drained and Chatfield moderately well drained) and one deep soil), the percentage of each soil type was 50% Chatfield, 25% Hollis, and 25% Rock Outcrop. The standard protocol is to utilize the dominant soil type for Hydrologic Soil Group, which is Chatfield (well drained and moderately well drained) with a Hydrologic Soil Group of B. Chatfield has a depth of 20 to 40 inches to bedrock. The Hydrologic Soil Groups are assigned to soil units by Publication Number 5 of the Society of Soil Scientists of Northern New England and adopted by NH DES Alteration of Terrain.

Hollis has a soil depth of 10 to 20 inches to bedrock. It also has a combined Hydrologic Soil Group of C/D. Rock Outcrop is any area that has surface exposed bedrock to 10 inches deep.

Typically for drainage analysis, the dominant hydrologic soil group is used, in this case B. Conversely, a weighted average could be used to mimic the complex: 50% B, 25% C/D, and 25% D-virtually impervious.

Complexes are difficult to interpret given that multiple soil types are present and randomly intermixed. It becomes even more difficult when the multiple soil types have differing characteristics.

Jim Gove, CSS #004

4-1-2024

DRAINAGE ANALYSIS
SEDIMENT AND EROSION CONTROL PLAN

“Luster Cluster”
635 Sagamore Ave.
Portsmouth, NH 03801
Tax Map 222, Lot 19

Prepared for:

635 Sagamore Development LLC
3612 Lafayette Rd., Dept 4
Portsmouth, NH 03801

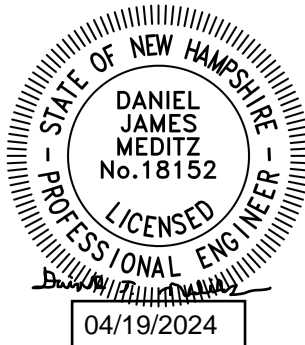

Prepared by:
Jones & Beach Engineers, Inc.
85 Portsmouth Avenue
P.O. Box 219
Stratham, NH 03885
(603) 772-4746
March 14, 2024
Revised April 18, 2024
JBE Project No. 18134.1

EXECUTIVE SUMMARY

635 Sagamore Development LLC proposes to demolish an existing commercial development and construct a 4-unit multi-family residential site on the subject parcel located at 635 Sagamore Ave. in Portsmouth, NH. In the existing condition, the subject parcel is home to two buildings and a paved parking area that used to comprise the “Luster King,” a former auto detailing business that has since closed.

A drainage analysis of the entire site as well as offsite contributing watershed area was conducted for the purpose of estimating the peak rate of stormwater runoff and to subsequently design adequate drainage structures. Two models were compiled, one for the area in its existing (pre-construction) condition, and a second for its proposed (post-construction) condition. The analysis was conducted using data for the 2 Year – 24 Hour (3.70”), 10 Year – 24 Hour (5.61”), 25 Year – 24 Hour (7.12”), and 50 Year – 24 Hour (8.53”) storm events using the USDA SCS TR-20 method within the HydroCAD Stormwater Modeling System environment. This data was taken from the Extreme Precipitation Tables developed by the Northeast Regional Climate Center (NRCC), and the values have been increased by 15% due to the project being within the Coastal/Great Bay Region. A summary of the existing and proposed conditions peak rates of runoff toward the three analysis points and toward the existing drainage ditch on the Tidewatch Condominium property (Reach 1R) in units of cubic feet per second (cfs) is as follows:

Analysis Point	2 Year		10 Year		25 Year		50 Year	
	Pre	Post	Pre	Post	Pre	Post	Pre	Post
Analysis Point #1	0.75	0.35	1.33	0.67	1.78	0.93	2.21	1.17
Analysis Point #2	0.20	0.02	0.44	0.08	0.65	0.12	0.84	0.17
Analysis Point #3	0.91	0.71	2.86	2.12	4.73	3.47	6.61	5.03
Reach #1R	0.51	0.48	1.75	1.47	2.94	2.41	4.17	3.98

A similar summary of the existing and proposed peak volumes in units of acre-feet is as follows:

Analysis Point	2 Year		10 Year		25 Year		50 Year	
	Pre	Post	Pre	Post	Pre	Post	Pre	Post
Analysis Point #1	0.054	0.025	0.098	0.048	0.133	0.068	0.167	0.087
Analysis Point #2	0.015	0.002	0.032	0.006	0.047	0.009	0.061	0.013
Analysis Point #3	0.118	0.118	0.302	0.279	0.477	0.436	0.656	0.629
Reach #1R	0.069	0.086	0.187	0.200	0.300	0.312	0.418	0.460

Although the volume of runoff directed toward Reach 1R is slightly increasing, the flow toward this reach is being reduced and the peak elevation will remain the same or be decreased in the proposed condition and the volume of runoff directed toward the downstream analysis point (AP3) is being reduced as well. A comparison of the peak elevations within the ditch pre- to post-construction is below:

Peak Elevation	2 Year		10 Year		25 Year		50 Year	
	Pre	Post	Pre	Post	Pre	Post	Pre	Post
Reach #1R	0.18'	0.18'	0.34'	0.32'	0.44'	0.40'	0.52'	0.51'

Peak flows and volumes are being reduced in the post-construction condition toward all analysis points during all analyzed storm events. The subject parcel is located in the Single Residence A (SRA) Zoning District. The subject parcel currently consists of the aforementioned former commercial site which is proposed to be demolished. Despite impervious surface existing on the subject parcel now, the proposed development results in an increase in impervious surface on the subject parcel. The addition of the proposed impervious surfaces causes an increase in the curve number (C_n) and a decrease in the time of concentration (T_c), and if a stormwater management system were not implemented, the net result of this would be a potential increase in peak rates of runoff from the site. In order to avoid this potential, a stormwater management system has been designed, consisting of a bioretention system with deep sump catch basins for pre-treatment of runoff, and stone drip edges. Due to the use of these stormwater management features, the peak flow and volume of runoff will be reduced toward all analysis points during all analyzed storm events in the proposed condition as compared to the existing condition, and the treatment requirements of the City of Portsmouth are met. Additionally, the NHDES Alteration of Terrain Bureau's groundwater recharge volume and channel protection requirements are met with the proposed development. **The stormwater management system as designed meets all requirements of the City of Portsmouth stormwater regulations per Section 7.1 and 7.4-7.6 of the Site Plan Review Regulations. Additionally, the stormwater management system as designed meets all requirements of the NHDES Alteration of Terrain (AOT) Bureau, even though an AOT permit is not necessary for this project due to the area of disturbance.**

The use of Best Management Practices per the NHDES Stormwater Manual have been applied to the design of this stormwater management system and will be observed during all stages of construction. All land disturbed during construction will be stabilized within thirty days of groundbreaking and abutting property owners will suffer minimal adversity resultant to this development.

TABLE OF CONTENTS

Executive Summary

- 1.0 Rainfall Characteristics
- 2.0 Existing Conditions Analysis
- 3.0 Proposed Conditions Analysis
- 4.0 Conclusion

Appendix I Existing Conditions Analysis

- 2 Year - 24 Hour Summary
- 10 Year - 24 Hour Complete
- 25 Year - 24 Hour Summary
- 50 Year - 24 Hour Complete

Appendix II Proposed Conditions Analysis

- 2 Year - 24 Hour Summary
- 10 Year - 24 Hour Complete
- 25 Year - 24 Hour Summary
- 50 Year - 24 Hour Complete

Appendix III Test Pit Logs

Appendix IV Site Specific Soil Survey and Map

Appendix V NRCS Soil Map

Appendix VI Extreme Precipitation Estimates

Appendix VII Rip Rap Calculations

Appendix VIII BMP Worksheets

Appendix IX Pollutant Removal Calculations

Appendix X Stormwater Operations and Maintenance Manual

Appendix XI Pre- and Post-Construction Watershed Plans

1.0 RAINFALL CHARACTERISTICS

This drainage report includes an existing conditions analysis of the area involved in the proposed development, as well as a proposed condition, or post-construction analysis, of the same area. These analyses were accomplished using the USDA SCS TR-20 Method within the HydroCAD 10.20-3c Stormwater Modeling System. The curve numbers were developed using the SCS TR-55 Runoff Curve numbers for Urban Areas. A Type III SCS 24-hour rainfall distribution was utilized in analyzing the data for the 2 Year – 24 Hour (3.70"), 10 Year – 24 Hour (5.61"), 25 Year – 24 Hour (7.12"), and 50 Year – 24 Hour (8.53") storm events. This data was taken from the Extreme Precipitation Tables developed by the Northeast Regional Climate Center (NRCC), and the values have been increased by 15% due to the project being within the Coastal/Great Bay Region.

The peak rates of runoff will be reduced from the existing condition, thereby minimizing any potential for a negative impact on abutting properties. This is accomplished through treatment of stormwater runoff and attenuation of peak flows and volumes resulting from storm events.

2.0 EXISTING CONDITIONS ANALYSIS

In the existing condition, the site consists of two commercial buildings as well as a shed and a paved parking area that comprise the former Luster King auto detailing business, which has since closed. Most of the area behind the existing commercial development is wooded with light underbrush and large ledge outcrops. Due to these features of the woodlands, the woods area has been modelled as "fair" rather than "good" for the purposes of stormwater runoff calculations. There is some lawn space around the existing developed area as well.

The existing topography and roof ridges divide the subject parcel and offsite contributing watershed areas into four subcatchments, draining toward three analysis points. Subcatchment 1 represents the front of the subject parcel as well as a stretch of the northbound lane of Sagamore Avenue. This subcatchment is entirely developed in the existing condition, and it drains directly into the Sagamore Ave. right of way, modelled as Analysis Point 1.

Subcatchment 2S represents a small section of the developed portion of the property which drains to the north and on to abutting Tax Map 222, Lot 20, modelled as Analysis Point 2. It is very important that peak flows and volumes draining toward Analysis Points 1 and 2 are reduced in the post-construction condition, as these two analysis points represent a highway and a house lot, respectively.

The largest subcatchment is Subcatchment 3S. Subcatchment 3S is roughly the western quarter of the property and it consists primarily of woodland with large ledge outcrops. Subcatchment 3S drains toward an existing drainage ditch alongside and below the grade of the Tidewatch Condominium private roadway, which is curbed so that no runoff from the roadway itself enters the ditch. This drainage ditch is modelled as Reach 1R and it drains toward Analysis Point 3. Analysis Point 3 is an existing catch basin adjacent to the community mailbox structure for Tidewatch Condominiums.

Finally, a section of both developed and undeveloped land in the western end of the property drains into abutting woodland on the Tidewatch Condominium property and ultimately toward the aforementioned catch basin that is modelled as Analysis Point 3.

Existing soil types were determined through a Site Specific Soil Survey conducted by a Certified Soil Scientist. The pervious soils are categorized into Hydrologic Soil Group (HSG) B while the

impervious areas of the subject parcel are categorized as Urban Land (SSS Symbol 699). The pervious sections of the property are represented as Chatfield-Hollis-Rock Outcrop complex and Chatfield Variant (moderately well drained). According to "Ksat Values for New Hampshire Soils," Special Publication No. 5 sponsored by the Society of Soil Scientists of Northern New England (SSSNNE), Chatfield, Chatfield Variant, and Hollis soils all have identical saturated hydraulic conductivity ranges in the B and C horizons. The saturated hydraulic conductivity (Ksat) value for these soils ranges from 0.6 to 6.0 inches/hour within both the B and C horizons. Therefore, in accordance with standard engineering practice, the lowest published Ksat of 0.6 in/hr for these soils types was divided by two in order to determine an appropriate Ksat of **0.3 in/hr** to use for design.

3.0 PROPOSED CONDITIONS ANALYSIS

The addition of the proposed impervious surfaces causes an increase in the curve number (C_n) and a decrease in the time of concentration (T_c), and if a stormwater management system were not implemented, the net result of this would be a potential increase in peak rates of runoff from the site. A stormwater management system was designed in order to avoid this potential. The proposed development, consisting of the aforementioned four (4) residential units with associated paved roadway and driveways as well as stormwater management features divide the subject parcel into fifteen (15) subcatchments. Subcatchments 1S, 2S, and 4S drain directly toward Analysis Points 1-3, respectively, as previously outlined. Subcatchment 3S drains toward the existing drainage ditch on the Tidewatch Condominium property, modelled as Reach 1R, which ultimately outlets toward AP3, the same as in the existing condition. Subcatchment 5S has been removed from the drainage analysis as it was the subcatchment associated with a stormwater pond that has since been removed from the drainage design. Subcatchments 6S-9S drain through deep sump catch basins into a closed drainage system which outlets toward a bioretention pond modelled as Pond 1P. The deep sump catch basins provide pre-treatment of runoff reaching the bioretention pond in lieu of a sediment forebay. The bioretention pond is designed to treat and infiltrate runoff directed toward it during smaller storms, or in larger storms, infiltrate as much as possible and attenuate and slowly discharge outflow. Any discharge from Pond 1P follows a path through Subcatchment 3S represented as Reach 4R, toward Reach 1R, the existing ditch on the Tidewatch condominium property leading to Analysis Point 3.

Subcatchments 10S-12S consist of lawn and roof areas that drain toward yard drains 1-3, respectively. The runoff that is caught by these yard drains additionally enters the previously described closed drainage system that outlets toward Pond 1P.

Subcatchments 13S, 14S, and 15S represent roof and deck areas on Units 3-4 which are routed toward infiltration systems adjacent to the units such as stone drip edges and stone underneath a deck. These devices are only featured in areas where the basement grade will be above the seasonal high water table and the top of ledge. These devices are modelled as Ponds 2P-4P.

Finally, Subcatchment 18S represents the grassed and roof area that drains directly toward Pond 1P without passing through the closed drainage system in the proposed condition.

As a result of the implementation of this stormwater management system, peak flows and runoff volumes are reduced toward all three analysis points during all analyzed storm events in the proposed condition as compared with the existing condition. The NHDES Alteration of Terrain Bureau allows an increase in runoff volume of up to 0.1 acre-feet during the 2-year 24-hour storm event. We are decreasing runoff volumes and therefore this would be approvable by the AOT Bureau if the project needed an AOT permit (which it does not as the area of disturbance is below 100,000 SF).

Furthermore, the project as designed exceeds the AOT Bureau's groundwater recharge volume requirement. A GRV worksheet is contained within the appendix of this report in order to illustrate this. Therefore, we have designed the drainage system to avoid adverse impacts to abutting infrastructure and the requirement per Section 7.1 of the Site Plan Review Regulations to "design practices to the maximum extent practical (MEP) to reduce stormwater runoff volumes, maintain predevelopment site hydrology, and protect water quality in receiving waters" is met. Furthermore, rain gardens (also known as bioretention systems) are recommended as a Low Impact Development practice in this same section of the regulations. We are using bioretention systems to treat and attenuate runoff from paved areas of the subject parcel in the proposed condition.

According to the NH Stormwater Manual, bioretention systems provide a pollutant removal efficiency of 90% for TSS and 65% for nitrogen, and drip edges provide a removal efficiency of 90% for TSS and 55% for nitrogen. The City of Portsmouth Site Plan Review Regulations stipulate that stormwater BMPs shall either be designed for 80% TSS removal and 50% nitrogen removal of stormwater runoff from impervious surfaces. This plan exceeds the requirements for pollutant removal because appropriate treatment / groundwater recharge systems are proposed and the Water Quality Volume is retained and treated. A breakdown of pollutant removal efficiencies for the entire site is contained within the appendix of this report.

5.0 CONCLUSION

This proposed site development will have minimal adverse effect on abutting infrastructures, properties, and downstream wetlands by way of stormwater runoff or siltation. Appropriate steps will be taken to eliminate erosion and sedimentation; these will be accomplished through the construction of a drainage system consisting of site grading, catch basins, yard drains, a bioretention system, stone drip edges, and temporary erosion control measures including but not limited to silt fence and the use of a stabilized construction entrance. Best Management Practices developed by the State of New Hampshire have been utilized in the design of this system and their application will be enforced throughout the construction process. Peak rates of runoff from the site will be reduced toward all analysis points during all analyzed storm events.

This project disturbs less than 100,000 S.F. and does not require a NHDES Alteration of Terrain Permit.

Respectfully Submitted,
JONES & BEACH ENGINEERS. INC.



Daniel Meditz, P.E.
Project Engineer

APPENDIX I

EXISTING CONDITIONS DRAINAGE ANALYSIS

Summary 2 YEAR
Complete 10 YEAR
Summary 25 YEAR
Complete 50 YEAR

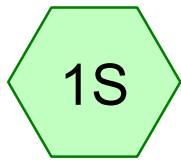

Subcatchment 1S

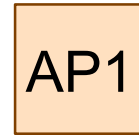

Analysis Point 1



Subcatchment 2S

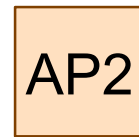

Analysis Point 2

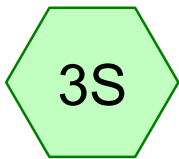

Subcatchment 3S

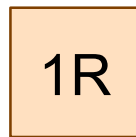

Ditch on Tidewatch Property

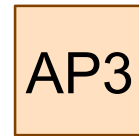

Analysis Point 3

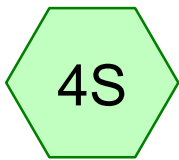

Subcatchment 4S

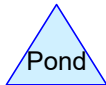
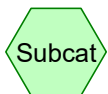

18134-EXISTING

Area Listing (all nodes)

Area (acres)	CN	Description (subcatchment-numbers)
0.547	61	>75% Grass cover, Good, HSG B (1S, 2S, 3S, 4S)
0.230	98	Paved parking, HSG B (1S, 2S, 4S)
0.114	98	Roofs, HSG B (1S, 2S, 3S, 4S)
1.538	60	Woods, Fair, HSG B (2S, 3S, 4S)
2.429	66	TOTAL AREA

18134-EXISTING

Soil Listing (all nodes)

Area (acres)	Soil Group	Subcatchment Numbers
0.000	HSG A	
2.429	HSG B	1S, 2S, 3S, 4S
0.000	HSG C	
0.000	HSG D	
0.000	Other	
2.429		TOTAL AREA

18134-EXISTING

Type III 24-hr 2 Yr 24 Hr +15% Rainfall=3.70"

Prepared by Jones & Beach Engineers Inc

Printed 4/19/2024

HydroCAD® 10.20-3c s/n 00762 © 2023 HydroCAD Software Solutions LLC

Page 4

Time span=0.00-24.00 hrs, dt=0.05 hrs, 481 points x 3
Runoff by SCS TR-20 method, UH=SCS, Weighted-CN
Reach routing by Dyn-Stor-Ind method - Pond routing by Dyn-Stor-Ind method

Subcatchment1S: Subcatchment1S Runoff Area=13,001 sf 64.94% Impervious Runoff Depth>2.19"
Flow Length=187' Tc=6.0 min CN=85 Runoff=0.75 cfs 0.054 af

Subcatchment2S: Subcatchment2S Runoff Area=6,082 sf 32.08% Impervious Runoff Depth>1.31"
Flow Length=114' Tc=6.0 min CN=73 Runoff=0.20 cfs 0.015 af

Subcatchment3S: Subcatchment3S Runoff Area=58,629 sf 0.32% Impervious Runoff Depth>0.62"
Flow Length=291' Tc=17.0 min CN=60 Runoff=0.51 cfs 0.069 af

Subcatchment4S: Subcatchment4S Runoff Area=28,091 sf 15.59% Impervious Runoff Depth>0.91"
Flow Length=216' Tc=11.5 min CN=66 Runoff=0.49 cfs 0.049 af

Reach 1R: Ditch on Tidewatch Property Avg. Flow Depth=0.18' Max Vel=1.77 fps Inflow=0.51 cfs 0.069 af
n=0.030 L=159.0' S=0.0189 '/' Capacity=18.18 cfs Outflow=0.51 cfs 0.069 af

Reach AP1: Analysis Point 1 Inflow=0.75 cfs 0.054 af
Outflow=0.75 cfs 0.054 af

Reach AP2: Analysis Point 2 Inflow=0.20 cfs 0.015 af
Outflow=0.20 cfs 0.015 af

Reach AP3: Analysis Point 3 Inflow=0.91 cfs 0.118 af
Outflow=0.91 cfs 0.118 af

Total Runoff Area = 2.429 ac Runoff Volume = 0.188 af Average Runoff Depth = 0.93"
85.86% Pervious = 2.085 ac 14.14% Impervious = 0.343 ac

18134-EXISTING

Type III 24-hr 10 Yr 24 Hr +15% Rainfall=5.61"

Prepared by Jones & Beach Engineers Inc

Printed 4/19/2024

HydroCAD® 10.20-3c s/n 00762 © 2023 HydroCAD Software Solutions LLC

Page 5

Time span=0.00-24.00 hrs, dt=0.05 hrs, 481 points x 3
Runoff by SCS TR-20 method, UH=SCS, Weighted-CN
Reach routing by Dyn-Stor-Ind method - Pond routing by Dyn-Stor-Ind method

Subcatchment1S: Subcatchment1S Runoff Area=13,001 sf 64.94% Impervious Runoff Depth>3.93"
Flow Length=187' Tc=6.0 min CN=85 Runoff=1.33 cfs 0.098 af

Subcatchment2S: Subcatchment2S Runoff Area=6,082 sf 32.08% Impervious Runoff Depth>2.77"
Flow Length=114' Tc=6.0 min CN=73 Runoff=0.44 cfs 0.032 af

Subcatchment3S: Subcatchment3S Runoff Area=58,629 sf 0.32% Impervious Runoff Depth>1.66"
Flow Length=291' Tc=17.0 min CN=60 Runoff=1.75 cfs 0.187 af

Subcatchment4S: Subcatchment4S Runoff Area=28,091 sf 15.59% Impervious Runoff Depth>2.15"
Flow Length=216' Tc=11.5 min CN=66 Runoff=1.31 cfs 0.116 af

Reach 1R: Ditch on Tidewatch Property Avg. Flow Depth=0.34' Max Vel=2.48 fps Inflow=1.75 cfs 0.187 af
n=0.030 L=159.0' S=0.0189 '/' Capacity=18.18 cfs Outflow=1.74 cfs 0.186 af

Reach AP1: Analysis Point 1 Inflow=1.33 cfs 0.098 af
Outflow=1.33 cfs 0.098 af

Reach AP2: Analysis Point 2 Inflow=0.44 cfs 0.032 af
Outflow=0.44 cfs 0.032 af

Reach AP3: Analysis Point 3 Inflow=2.86 cfs 0.302 af
Outflow=2.86 cfs 0.302 af

Total Runoff Area = 2.429 ac Runoff Volume = 0.432 af Average Runoff Depth = 2.14"
85.86% Pervious = 2.085 ac 14.14% Impervious = 0.343 ac

18134-EXISTING

Type III 24-hr 10 Yr 24 Hr +15% Rainfall=5.61"

Prepared by Jones & Beach Engineers Inc

Printed 4/19/2024

HydroCAD® 10.20-3c s/n 00762 © 2023 HydroCAD Software Solutions LLC

Page 6

Summary for Subcatchment 1S: Subcatchment 1S

Runoff = 1.33 cfs @ 12.09 hrs, Volume= 0.098 af, Depth> 3.93"
 Routed to Reach AP1 : Analysis Point 1

Runoff by SCS TR-20 method, UH=SCS, Weighted-CN, Time Span= 0.00-24.00 hrs, dt= 0.05 hrs
 Type III 24-hr 10 Yr 24 Hr +15% Rainfall=5.61"

Area (sf)	CN	Description
1,476	98	Roofs, HSG B
6,967	98	Paved parking, HSG B
4,558	61	>75% Grass cover, Good, HSG B
13,001	85	Weighted Average
4,558		35.06% Pervious Area
8,443		64.94% Impervious Area

Tc (min)	Length (feet)	Slope (ft/ft)	Velocity (ft/sec)	Capacity (cfs)	Description
2.5	46	0.1090	0.31		Sheet Flow, Grass: Short n= 0.150 P2= 3.70"
0.4	45	0.0670	2.04		Sheet Flow, Smooth surfaces n= 0.011 P2= 3.70"
0.4	96	0.0360	3.85		Shallow Concentrated Flow, Paved Kv= 20.3 fps
3.3	187	Total, Increased to minimum Tc = 6.0 min			

Summary for Subcatchment 2S: Subcatchment 2S

Runoff = 0.44 cfs @ 12.09 hrs, Volume= 0.032 af, Depth> 2.77"
 Routed to Reach AP2 : Analysis Point 2

Runoff by SCS TR-20 method, UH=SCS, Weighted-CN, Time Span= 0.00-24.00 hrs, dt= 0.05 hrs
 Type III 24-hr 10 Yr 24 Hr +15% Rainfall=5.61"

Area (sf)	CN	Description
482	98	Roofs, HSG B
1,469	98	Paved parking, HSG B
3,981	61	>75% Grass cover, Good, HSG B
150	60	Woods, Fair, HSG B
6,082	73	Weighted Average
4,131		67.92% Pervious Area
1,951		32.08% Impervious Area

18134-EXISTING

Type III 24-hr 10 Yr 24 Hr +15% Rainfall=5.61"

Prepared by Jones & Beach Engineers Inc

Printed 4/19/2024

HydroCAD® 10.20-3c s/n 00762 © 2023 HydroCAD Software Solutions LLC

Page 7

Tc (min)	Length (feet)	Slope (ft/ft)	Velocity (ft/sec)	Capacity (cfs)	Description
0.7	53	0.0200	1.30		Sheet Flow, Smooth surfaces n= 0.011 P2= 3.70"
2.8	47	0.0810	0.28		Sheet Flow, Grass: Short n= 0.150 P2= 3.70"
0.1	14	0.2100	3.21		Shallow Concentrated Flow, Short Grass Pasture Kv= 7.0 fps
3.6	114	Total, Increased to minimum Tc = 6.0 min			

Summary for Subcatchment 3S: Subcatchment 3S

Runoff = 1.75 cfs @ 12.26 hrs, Volume= 0.187 af, Depth> 1.66"
Routed to Reach 1R : Ditch on Tidewatch Property

Runoff by SCS TR-20 method, UH=SCS, Weighted-CN, Time Span= 0.00-24.00 hrs, dt= 0.05 hrs
Type III 24-hr 10 Yr 24 Hr +15% Rainfall=5.61"

Area (sf)	CN	Description
187	98	Roofs, HSG B
9,391	61	>75% Grass cover, Good, HSG B
49,051	60	Woods, Fair, HSG B
58,629	60	Weighted Average
58,442		99.68% Pervious Area
187		0.32% Impervious Area

Tc (min)	Length (feet)	Slope (ft/ft)	Velocity (ft/sec)	Capacity (cfs)	Description
9.0	53	0.0415	0.10		Sheet Flow, Woods: Light underbrush n= 0.400 P2= 3.70"
5.8	47	0.0968	0.13		Sheet Flow, Woods: Light underbrush n= 0.400 P2= 3.70"
0.2	15	0.0968	1.56		Shallow Concentrated Flow, Woodland Kv= 5.0 fps
0.7	54	0.0741	1.36		Shallow Concentrated Flow, Woodland Kv= 5.0 fps
1.3	122	0.1000	1.58		Shallow Concentrated Flow, Woodland Kv= 5.0 fps
17.0	291	Total			

Summary for Subcatchment 4S: Subcatchment 4S

Runoff = 1.31 cfs @ 12.17 hrs, Volume= 0.116 af, Depth> 2.15"
Routed to Reach AP3 : Analysis Point 3

Runoff by SCS TR-20 method, UH=SCS, Weighted-CN, Time Span= 0.00-24.00 hrs, dt= 0.05 hrs
Type III 24-hr 10 Yr 24 Hr +15% Rainfall=5.61"

18134-EXISTING

Type III 24-hr 10 Yr 24 Hr +15% Rainfall=5.61"

Prepared by Jones & Beach Engineers Inc

Printed 4/19/2024

HydroCAD® 10.20-3c s/n 00762 © 2023 HydroCAD Software Solutions LLC

Page 8

Area (sf)	CN	Description
2,809	98	Roofs, HSG B
1,571	98	Paved parking, HSG B
5,912	61	>75% Grass cover, Good, HSG B
17,799	60	Woods, Fair, HSG B
28,091	66	Weighted Average
23,711		84.41% Pervious Area
4,380		15.59% Impervious Area

Tc (min)	Length (feet)	Slope (ft/ft)	Velocity (ft/sec)	Capacity (cfs)	Description
1.9	14	0.0210	0.13		Sheet Flow, Grass: Short n= 0.150 P2= 3.70"
8.4	86	0.1280	0.17		Sheet Flow, Woods: Light underbrush n= 0.400 P2= 3.70"
1.0	87	0.0800	1.41		Shallow Concentrated Flow, Woodland Kv= 5.0 fps
0.2	29	0.2860	2.67		Shallow Concentrated Flow, Woodland Kv= 5.0 fps
11.5	216	Total			

Summary for Reach 1R: Ditch on Tidewatch Property

Inflow Area = 1.346 ac, 0.32% Impervious, Inflow Depth > 1.66" for 10 Yr 24 Hr +15% event
 Inflow = 1.75 cfs @ 12.26 hrs, Volume= 0.187 af
 Outflow = 1.74 cfs @ 12.27 hrs, Volume= 0.186 af, Atten= 0%, Lag= 0.7 min
 Routed to Reach AP3 : Analysis Point 3

Routing by Dyn-Stor-Ind method, Time Span= 0.00-24.00 hrs, dt= 0.05 hrs / 3
 Max. Velocity= 2.48 fps, Min. Travel Time= 1.1 min
 Avg. Velocity = 1.11 fps, Avg. Travel Time= 2.4 min

Peak Storage= 112 cf @ 12.27 hrs
 Average Depth at Peak Storage= 0.34' , Surface Width= 3.07'
 Bank-Full Depth= 1.00' Flow Area= 4.0 sf, Capacity= 18.18 cfs

1.00' x 1.00' deep channel, n= 0.030 Stream, clean & straight
 Side Slope Z-value= 3.0 '/' Top Width= 7.00'
 Length= 159.0' Slope= 0.0189 '/'
 Inlet Invert= 38.00', Outlet Invert= 35.00'



Summary for Reach AP1: Analysis Point 1

[40] Hint: Not Described (Outflow=Inflow)

Inflow Area =	0.298 ac, 64.94% Impervious, Inflow Depth > 3.93"	for 10 Yr 24 Hr +15% event
Inflow =	1.33 cfs @ 12.09 hrs, Volume=	0.098 af
Outflow =	1.33 cfs @ 12.09 hrs, Volume=	0.098 af, Atten= 0%, Lag= 0.0 min

Routing by Dyn-Stor-Ind method, Time Span= 0.00-24.00 hrs, dt= 0.05 hrs / 3

Summary for Reach AP2: Analysis Point 2

[40] Hint: Not Described (Outflow=Inflow)

Inflow Area =	0.140 ac, 32.08% Impervious, Inflow Depth > 2.77"	for 10 Yr 24 Hr +15% event
Inflow =	0.44 cfs @ 12.09 hrs, Volume=	0.032 af
Outflow =	0.44 cfs @ 12.09 hrs, Volume=	0.032 af, Atten= 0%, Lag= 0.0 min

Routing by Dyn-Stor-Ind method, Time Span= 0.00-24.00 hrs, dt= 0.05 hrs / 3

Summary for Reach AP3: Analysis Point 3

[40] Hint: Not Described (Outflow=Inflow)

Inflow Area =	1.991 ac, 5.27% Impervious, Inflow Depth > 1.82"	for 10 Yr 24 Hr +15% event
Inflow =	2.86 cfs @ 12.23 hrs, Volume=	0.302 af
Outflow =	2.86 cfs @ 12.23 hrs, Volume=	0.302 af, Atten= 0%, Lag= 0.0 min

Routing by Dyn-Stor-Ind method, Time Span= 0.00-24.00 hrs, dt= 0.05 hrs / 3

18134-EXISTING

Type III 24-hr 25 Yr 24 Hr +15% Rainfall=7.12"

Prepared by Jones & Beach Engineers Inc

Printed 4/19/2024

HydroCAD® 10.20-3c s/n 00762 © 2023 HydroCAD Software Solutions LLC

Page 10

Time span=0.00-24.00 hrs, dt=0.05 hrs, 481 points x 3
Runoff by SCS TR-20 method, UH=SCS, Weighted-CN
Reach routing by Dyn-Stor-Ind method - Pond routing by Dyn-Stor-Ind method

Subcatchment1S: Subcatchment1S Runoff Area=13,001 sf 64.94% Impervious Runoff Depth>5.36"
Flow Length=187' Tc=6.0 min CN=85 Runoff=1.78 cfs 0.133 af

Subcatchment2S: Subcatchment2S Runoff Area=6,082 sf 32.08% Impervious Runoff Depth>4.04"
Flow Length=114' Tc=6.0 min CN=73 Runoff=0.65 cfs 0.047 af

Subcatchment3S: Subcatchment3S Runoff Area=58,629 sf 0.32% Impervious Runoff Depth>2.68"
Flow Length=291' Tc=17.0 min CN=60 Runoff=2.94 cfs 0.300 af

Subcatchment4S: Subcatchment4S Runoff Area=28,091 sf 15.59% Impervious Runoff Depth>3.29"
Flow Length=216' Tc=11.5 min CN=66 Runoff=2.05 cfs 0.177 af

Reach 1R: Ditch on Tidewatch Property Avg. Flow Depth=0.44' Max Vel=2.85 fps Inflow=2.94 cfs 0.300 af
n=0.030 L=159.0' S=0.0189 '/' Capacity=18.18 cfs Outflow=2.94 cfs 0.300 af

Reach AP1: Analysis Point 1 Inflow=1.78 cfs 0.133 af
Outflow=1.78 cfs 0.133 af

Reach AP2: Analysis Point 2 Inflow=0.65 cfs 0.047 af
Outflow=0.65 cfs 0.047 af

Reach AP3: Analysis Point 3 Inflow=4.73 cfs 0.477 af
Outflow=4.73 cfs 0.477 af

Total Runoff Area = 2.429 ac Runoff Volume = 0.658 af Average Runoff Depth = 3.25"
85.86% Pervious = 2.085 ac 14.14% Impervious = 0.343 ac

18134-EXISTING

Type III 24-hr 50 Yr 24 Hr +15% Rainfall=8.53"

Prepared by Jones & Beach Engineers Inc

Printed 4/19/2024

HydroCAD® 10.20-3c s/n 00762 © 2023 HydroCAD Software Solutions LLC

Page 11

Time span=0.00-24.00 hrs, dt=0.05 hrs, 481 points x 3
 Runoff by SCS TR-20 method, UH=SCS, Weighted-CN
 Reach routing by Dyn-Stor-Ind method - Pond routing by Dyn-Stor-Ind method

Subcatchment1S: Subcatchment1S Runoff Area=13,001 sf 64.94% Impervious Runoff Depth>6.72"
 Flow Length=187' Tc=6.0 min CN=85 Runoff=2.21 cfs 0.167 af

Subcatchment2S: Subcatchment2S Runoff Area=6,082 sf 32.08% Impervious Runoff Depth>5.28"
 Flow Length=114' Tc=6.0 min CN=73 Runoff=0.84 cfs 0.061 af

Subcatchment3S: Subcatchment3S Runoff Area=58,629 sf 0.32% Impervious Runoff Depth>3.72"
 Flow Length=291' Tc=17.0 min CN=60 Runoff=4.17 cfs 0.418 af

Subcatchment4S: Subcatchment4S Runoff Area=28,091 sf 15.59% Impervious Runoff Depth>4.44"
 Flow Length=216' Tc=11.5 min CN=66 Runoff=2.78 cfs 0.238 af

Reach 1R: Ditch on Tidewatch Property Avg. Flow Depth=0.52' Max Vel=3.12 fps Inflow=4.17 cfs 0.418 af
 n=0.030 L=159.0' S=0.0189 '/' Capacity=18.18 cfs Outflow=4.17 cfs 0.417 af

Reach AP1: Analysis Point 1 Inflow=2.21 cfs 0.167 af
 Outflow=2.21 cfs 0.167 af

Reach AP2: Analysis Point 2 Inflow=0.84 cfs 0.061 af
 Outflow=0.84 cfs 0.061 af

Reach AP3: Analysis Point 3 Inflow=6.61 cfs 0.656 af
 Outflow=6.61 cfs 0.656 af

Total Runoff Area = 2.429 ac Runoff Volume = 0.884 af Average Runoff Depth = 4.37"
85.86% Pervious = 2.085 ac 14.14% Impervious = 0.343 ac

18134-EXISTING

Type III 24-hr 50 Yr 24 Hr +15% Rainfall=8.53"

Prepared by Jones & Beach Engineers Inc

Printed 4/19/2024

HydroCAD® 10.20-3c s/n 00762 © 2023 HydroCAD Software Solutions LLC

Page 12

Summary for Subcatchment 1S: Subcatchment 1S

Runoff = 2.21 cfs @ 12.09 hrs, Volume= 0.167 af, Depth> 6.72"
 Routed to Reach AP1 : Analysis Point 1

Runoff by SCS TR-20 method, UH=SCS, Weighted-CN, Time Span= 0.00-24.00 hrs, dt= 0.05 hrs
 Type III 24-hr 50 Yr 24 Hr +15% Rainfall=8.53"

Area (sf)	CN	Description
1,476	98	Roofs, HSG B
6,967	98	Paved parking, HSG B
4,558	61	>75% Grass cover, Good, HSG B
13,001	85	Weighted Average
4,558		35.06% Pervious Area
8,443		64.94% Impervious Area

Tc (min)	Length (feet)	Slope (ft/ft)	Velocity (ft/sec)	Capacity (cfs)	Description
2.5	46	0.1090	0.31		Sheet Flow, Grass: Short n= 0.150 P2= 3.70"
0.4	45	0.0670	2.04		Sheet Flow, Smooth surfaces n= 0.011 P2= 3.70"
0.4	96	0.0360	3.85		Shallow Concentrated Flow, Paved Kv= 20.3 fps
3.3	187	Total, Increased to minimum Tc = 6.0 min			

Summary for Subcatchment 2S: Subcatchment 2S

Runoff = 0.84 cfs @ 12.09 hrs, Volume= 0.061 af, Depth> 5.28"
 Routed to Reach AP2 : Analysis Point 2

Runoff by SCS TR-20 method, UH=SCS, Weighted-CN, Time Span= 0.00-24.00 hrs, dt= 0.05 hrs
 Type III 24-hr 50 Yr 24 Hr +15% Rainfall=8.53"

Area (sf)	CN	Description
482	98	Roofs, HSG B
1,469	98	Paved parking, HSG B
3,981	61	>75% Grass cover, Good, HSG B
150	60	Woods, Fair, HSG B
6,082	73	Weighted Average
4,131		67.92% Pervious Area
1,951		32.08% Impervious Area

18134-EXISTING

Type III 24-hr 50 Yr 24 Hr +15% Rainfall=8.53"

Prepared by Jones & Beach Engineers Inc

Printed 4/19/2024

HydroCAD® 10.20-3c s/n 00762 © 2023 HydroCAD Software Solutions LLC

Page 13

Tc (min)	Length (feet)	Slope (ft/ft)	Velocity (ft/sec)	Capacity (cfs)	Description
0.7	53	0.0200	1.30		Sheet Flow, Smooth surfaces n= 0.011 P2= 3.70"
2.8	47	0.0810	0.28		Sheet Flow, Grass: Short n= 0.150 P2= 3.70"
0.1	14	0.2100	3.21		Shallow Concentrated Flow, Short Grass Pasture Kv= 7.0 fps
3.6	114	Total, Increased to minimum Tc = 6.0 min			

Summary for Subcatchment 3S: Subcatchment 3S

Runoff = 4.17 cfs @ 12.24 hrs, Volume= 0.418 af, Depth> 3.72"
Routed to Reach 1R : Ditch on Tidewatch Property

Runoff by SCS TR-20 method, UH=SCS, Weighted-CN, Time Span= 0.00-24.00 hrs, dt= 0.05 hrs
Type III 24-hr 50 Yr 24 Hr +15% Rainfall=8.53"

Area (sf)	CN	Description
187	98	Roofs, HSG B
9,391	61	>75% Grass cover, Good, HSG B
49,051	60	Woods, Fair, HSG B
58,629	60	Weighted Average
58,442		99.68% Pervious Area
187		0.32% Impervious Area

Tc (min)	Length (feet)	Slope (ft/ft)	Velocity (ft/sec)	Capacity (cfs)	Description
9.0	53	0.0415	0.10		Sheet Flow, Woods: Light underbrush n= 0.400 P2= 3.70"
5.8	47	0.0968	0.13		Sheet Flow, Woods: Light underbrush n= 0.400 P2= 3.70"
0.2	15	0.0968	1.56		Shallow Concentrated Flow, Woodland Kv= 5.0 fps
0.7	54	0.0741	1.36		Shallow Concentrated Flow, Woodland Kv= 5.0 fps
1.3	122	0.1000	1.58		Shallow Concentrated Flow, Woodland Kv= 5.0 fps
17.0	291	Total			

Summary for Subcatchment 4S: Subcatchment 4S

Runoff = 2.78 cfs @ 12.16 hrs, Volume= 0.238 af, Depth> 4.44"
Routed to Reach AP3 : Analysis Point 3

Runoff by SCS TR-20 method, UH=SCS, Weighted-CN, Time Span= 0.00-24.00 hrs, dt= 0.05 hrs
Type III 24-hr 50 Yr 24 Hr +15% Rainfall=8.53"

18134-EXISTING

Type III 24-hr 50 Yr 24 Hr +15% Rainfall=8.53"

Prepared by Jones & Beach Engineers Inc

Printed 4/19/2024

HydroCAD® 10.20-3c s/n 00762 © 2023 HydroCAD Software Solutions LLC

Page 14

Area (sf)	CN	Description
2,809	98	Roofs, HSG B
1,571	98	Paved parking, HSG B
5,912	61	>75% Grass cover, Good, HSG B
17,799	60	Woods, Fair, HSG B
28,091	66	Weighted Average
23,711		84.41% Pervious Area
4,380		15.59% Impervious Area

Tc (min)	Length (feet)	Slope (ft/ft)	Velocity (ft/sec)	Capacity (cfs)	Description
1.9	14	0.0210	0.13		Sheet Flow, Grass: Short n= 0.150 P2= 3.70"
8.4	86	0.1280	0.17		Sheet Flow, Woods: Light underbrush n= 0.400 P2= 3.70"
1.0	87	0.0800	1.41		Shallow Concentrated Flow, Woodland Kv= 5.0 fps
0.2	29	0.2860	2.67		Shallow Concentrated Flow, Woodland Kv= 5.0 fps
11.5	216	Total			

Summary for Reach 1R: Ditch on Tidewatch Property

Inflow Area = 1.346 ac, 0.32% Impervious, Inflow Depth > 3.72" for 50 Yr 24 Hr +15% event
 Inflow = 4.17 cfs @ 12.24 hrs, Volume= 0.418 af
 Outflow = 4.17 cfs @ 12.26 hrs, Volume= 0.417 af, Atten= 0%, Lag= 0.7 min
 Routed to Reach AP3 : Analysis Point 3

Routing by Dyn-Stor-Ind method, Time Span= 0.00-24.00 hrs, dt= 0.05 hrs / 3
 Max. Velocity= 3.12 fps, Min. Travel Time= 0.8 min
 Avg. Velocity = 1.34 fps, Avg. Travel Time= 2.0 min

Peak Storage= 212 cf @ 12.26 hrs
 Average Depth at Peak Storage= 0.52' , Surface Width= 4.12'
 Bank-Full Depth= 1.00' Flow Area= 4.0 sf, Capacity= 18.18 cfs

1.00' x 1.00' deep channel, n= 0.030 Stream, clean & straight
 Side Slope Z-value= 3.0 '/' Top Width= 7.00'
 Length= 159.0' Slope= 0.0189 '/'
 Inlet Invert= 38.00', Outlet Invert= 35.00'



Summary for Reach AP1: Analysis Point 1

[40] Hint: Not Described (Outflow=Inflow)

Inflow Area = 0.298 ac, 64.94% Impervious, Inflow Depth > 6.72" for 50 Yr 24 Hr +15% event
Inflow = 2.21 cfs @ 12.09 hrs, Volume= 0.167 af
Outflow = 2.21 cfs @ 12.09 hrs, Volume= 0.167 af, Atten= 0%, Lag= 0.0 min

Routing by Dyn-Stor-Ind method, Time Span= 0.00-24.00 hrs, dt= 0.05 hrs / 3

Summary for Reach AP2: Analysis Point 2

[40] Hint: Not Described (Outflow=Inflow)

Inflow Area = 0.140 ac, 32.08% Impervious, Inflow Depth > 5.28" for 50 Yr 24 Hr +15% event
Inflow = 0.84 cfs @ 12.09 hrs, Volume= 0.061 af
Outflow = 0.84 cfs @ 12.09 hrs, Volume= 0.061 af, Atten= 0%, Lag= 0.0 min

Routing by Dyn-Stor-Ind method, Time Span= 0.00-24.00 hrs, dt= 0.05 hrs / 3

Summary for Reach AP3: Analysis Point 3

[40] Hint: Not Described (Outflow=Inflow)

Inflow Area = 1.991 ac, 5.27% Impervious, Inflow Depth > 3.95" for 50 Yr 24 Hr +15% event
Inflow = 6.61 cfs @ 12.22 hrs, Volume= 0.656 af
Outflow = 6.61 cfs @ 12.22 hrs, Volume= 0.656 af, Atten= 0%, Lag= 0.0 min

Routing by Dyn-Stor-Ind method, Time Span= 0.00-24.00 hrs, dt= 0.05 hrs / 3

APPENDIX II

PROPOSED CONDITIONS DRAINAGE ANALYSIS

Summary 2 YEAR
Complete 10 YEAR
Summary 25 YEAR
Complete 50 YEAR

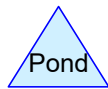
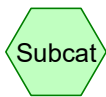
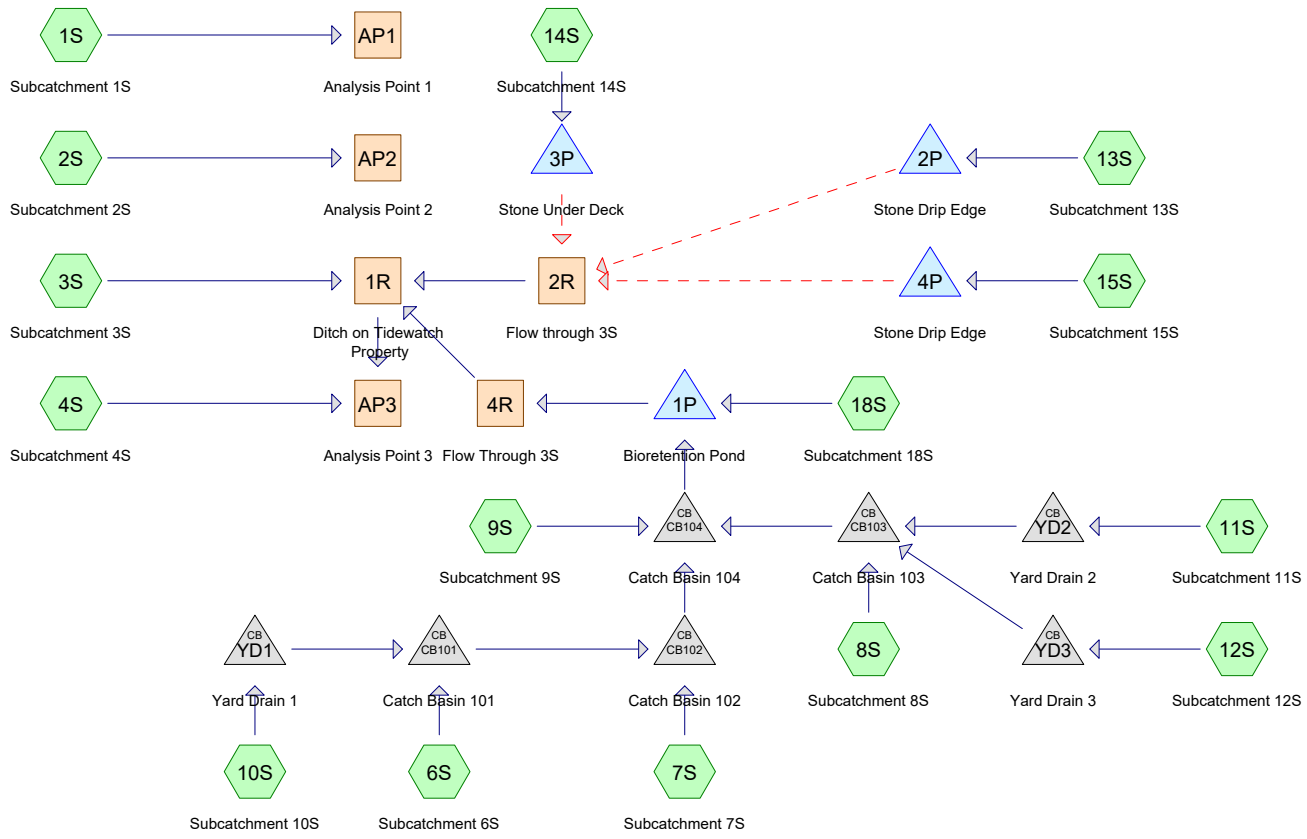

Routing Diagram for 18134-PROPOSED
 Prepared by Jones & Beach Engineers Inc, Printed 4/19/2024
 HydroCAD® 10.20-3c s/n 00762 © 2023 HydroCAD Software Solutions LLC

18134-PROPOSED

Area Listing (all nodes)

Area (acres)	CN	Description (subcatchment-numbers)
1.116	61	>75% Grass cover, Good, HSG B (1S, 2S, 3S, 4S, 10S, 11S, 12S, 18S)
0.253	98	Paved parking, HSG B (1S, 6S, 7S, 8S, 9S, 10S, 11S, 18S)
0.226	98	Roofs, HSG B (3S, 4S, 8S, 10S, 11S, 12S, 13S, 14S, 15S, 18S)
0.008	98	Water Surface, HSG B (13S, 15S)
0.826	60	Woods, Fair, HSG B (3S, 4S)
2.429	68	TOTAL AREA

18134-PROPOSED

Soil Listing (all nodes)

Area (acres)	Soil Group	Subcatchment Numbers
0.000	HSG A	
2.429	HSG B	1S, 2S, 3S, 4S, 6S, 7S, 8S, 9S, 10S, 11S, 12S, 13S, 14S, 15S, 18S
0.000	HSG C	
0.000	HSG D	
0.000	Other	
2.429		TOTAL AREA

18134-PROPOSED

Type III 24-hr 2 Yr 24 Hr +15% Rainfall=3.70"

Prepared by Jones & Beach Engineers Inc

Printed 4/19/2024

HydroCAD® 10.20-3c s/n 00762 © 2023 HydroCAD Software Solutions LLC

Page 4

Time span=0.00-24.00 hrs, dt=0.05 hrs, 481 points x 3
 Runoff by SCS TR-20 method, UH=SCS, Weighted-CN
 Reach routing by Dyn-Stor-Ind method - Pond routing by Dyn-Stor-Ind method

Subcatchment1S: Subcatchment1S	Runoff Area=7,392 sf 50.61% Impervious Runoff Depth>1.79" Flow Length=186' Tc=6.0 min CN=80 Runoff=0.35 cfs 0.025 af
Subcatchment2S: Subcatchment2S	Runoff Area=1,728 sf 0.00% Impervious Runoff Depth>0.66" Flow Length=20' Slope=0.0500 '/' Tc=6.0 min CN=61 Runoff=0.02 cfs 0.002 af
Subcatchment3S: Subcatchment3S	Runoff Area=45,177 sf 1.54% Impervious Runoff Depth>0.66" Flow Length=291' Tc=17.0 min CN=61 Runoff=0.44 cfs 0.057 af
Subcatchment4S: Subcatchment4S	Runoff Area=20,991 sf 8.04% Impervious Runoff Depth>0.81" Flow Length=210' Tc=7.9 min CN=64 Runoff=0.35 cfs 0.032 af
Subcatchment6S: Subcatchment6S	Runoff Area=1,952 sf 100.00% Impervious Runoff Depth>3.46" Tc=6.0 min CN=98 Runoff=0.16 cfs 0.013 af
Subcatchment7S: Subcatchment7S	Runoff Area=1,516 sf 100.00% Impervious Runoff Depth>3.46" Tc=6.0 min CN=98 Runoff=0.12 cfs 0.010 af
Subcatchment8S: Subcatchment8S	Runoff Area=3,011 sf 100.00% Impervious Runoff Depth>3.46" Tc=6.0 min CN=98 Runoff=0.24 cfs 0.020 af
Subcatchment9S: Subcatchment9S	Runoff Area=325 sf 100.00% Impervious Runoff Depth>3.46" Tc=6.0 min CN=98 Runoff=0.03 cfs 0.002 af
Subcatchment10S: Subcatchment10S	Runoff Area=3,630 sf 29.12% Impervious Runoff Depth>1.25" Flow Length=142' Tc=6.3 min CN=72 Runoff=0.11 cfs 0.009 af
Subcatchment11S: Subcatchment11S	Runoff Area=4,571 sf 49.42% Impervious Runoff Depth>1.72" Flow Length=77' Slope=0.0396 '/' Tc=6.0 min CN=79 Runoff=0.21 cfs 0.015 af
Subcatchment12S: Subcatchment12S	Runoff Area=3,734 sf 35.30% Impervious Runoff Depth>1.38" Flow Length=51' Slope=0.0320 '/' Tc=6.0 min CN=74 Runoff=0.13 cfs 0.010 af
Subcatchment13S: Subcatchment13S	Runoff Area=876 sf 100.00% Impervious Runoff Depth>3.46" Tc=6.0 min CN=98 Runoff=0.07 cfs 0.006 af
Subcatchment14S: Subcatchment14S	Runoff Area=560 sf 100.00% Impervious Runoff Depth>3.46" Tc=6.0 min CN=98 Runoff=0.05 cfs 0.004 af
Subcatchment15S: Subcatchment15S	Runoff Area=876 sf 100.00% Impervious Runoff Depth>3.46" Tc=6.0 min CN=98 Runoff=0.07 cfs 0.006 af
Subcatchment18S: Subcatchment18S	Runoff Area=9,474 sf 14.12% Impervious Runoff Depth>0.91" Flow Length=58' Tc=6.0 min CN=66 Runoff=0.20 cfs 0.016 af
Reach 1R: Ditch on Tidewatch Property	Avg. Flow Depth=0.18' Max Vel=1.74 fps Inflow=0.48 cfs 0.086 af n=0.030 L=159.0' S=0.0189 '/' Capacity=18.18 cfs Outflow=0.48 cfs 0.086 af

18134-PROPOSED

Type III 24-hr 2 Yr 24 Hr +15% Rainfall=3.70"

Prepared by Jones & Beach Engineers Inc

Printed 4/19/2024

HydroCAD® 10.20-3c s/n 00762 © 2023 HydroCAD Software Solutions LLC

Page 5

Reach 2R: Flow through 3S	Avg. Flow Depth=0.00' Max Vel=0.00 fps Inflow=0.00 cfs 0.000 af n=0.030 L=81.0' S=0.3457 '/' Capacity=740.30 cfs Outflow=0.00 cfs 0.000 af
Reach 4R: Flow Through 3S	Avg. Flow Depth=0.01' Max Vel=0.94 fps Inflow=0.04 cfs 0.029 af n=0.030 L=220.0' S=0.0909 '/' Capacity=66.79 cfs Outflow=0.04 cfs 0.029 af
Reach AP1: Analysis Point 1	Inflow=0.35 cfs 0.025 af Outflow=0.35 cfs 0.025 af
Reach AP2: Analysis Point 2	Inflow=0.02 cfs 0.002 af Outflow=0.02 cfs 0.002 af
Reach AP3: Analysis Point 3	Inflow=0.71 cfs 0.118 af Outflow=0.71 cfs 0.118 af
Pond 1P: Bioretention Pond	Peak Elev=61.42' Storage=1,704 cf Inflow=1.20 cfs 0.095 af Discarded=0.08 cfs 0.063 af Primary=0.04 cfs 0.029 af Outflow=0.12 cfs 0.092 af
Pond 2P: Stone Drip Edge	Peak Elev=64.62' Storage=0.004 af Inflow=0.07 cfs 0.006 af Discarded=0.00 cfs 0.003 af Secondary=0.00 cfs 0.000 af Outflow=0.00 cfs 0.003 af
Pond 3P: Stone Under Deck	Peak Elev=65.44' Storage=0.002 af Inflow=0.05 cfs 0.004 af Discarded=0.00 cfs 0.003 af Secondary=0.00 cfs 0.000 af Outflow=0.00 cfs 0.003 af
Pond 4P: Stone Drip Edge	Peak Elev=63.39' Storage=0.003 af Inflow=0.07 cfs 0.006 af Discarded=0.00 cfs 0.004 af Secondary=0.00 cfs 0.000 af Outflow=0.00 cfs 0.004 af
Pond CB101: Catch Basin 101	Peak Elev=62.62' Inflow=0.27 cfs 0.022 af 12.0" Round Culvert n=0.012 L=19.0' S=0.0053 '/' Outflow=0.27 cfs 0.022 af
Pond CB102: Catch Basin 102	Peak Elev=62.47' Inflow=0.39 cfs 0.032 af 12.0" Round Culvert n=0.012 L=147.0' S=0.0054 '/' Outflow=0.39 cfs 0.032 af
Pond CB103: Catch Basin 103	Peak Elev=66.74' Inflow=0.58 cfs 0.045 af 12.0" Round Culvert n=0.012 L=43.0' S=0.0070 '/' Outflow=0.58 cfs 0.045 af
Pond CB104: Catch Basin 104	Peak Elev=61.79' Inflow=1.00 cfs 0.079 af 12.0" Round Culvert n=0.012 L=45.0' S=0.0067 '/' Outflow=1.00 cfs 0.079 af
Pond YD1: Yard Drain 1	Peak Elev=63.01' Inflow=0.11 cfs 0.009 af 8.0" Round Culvert n=0.012 L=9.0' S=0.0189 '/' Outflow=0.11 cfs 0.009 af
Pond YD2: Yard Drain 2	Peak Elev=67.39' Inflow=0.21 cfs 0.015 af 8.0" Round Culvert n=0.012 L=52.0' S=0.0058 '/' Outflow=0.21 cfs 0.015 af
Pond YD3: Yard Drain 3	Peak Elev=68.23' Inflow=0.13 cfs 0.010 af 8.0" Round Culvert n=0.012 L=13.0' S=0.0923 '/' Outflow=0.13 cfs 0.010 af

Total Runoff Area = 2.429 ac Runoff Volume = 0.228 af Average Runoff Depth = 1.12"
79.95% Pervious = 1.942 ac 20.05% Impervious = 0.487 ac

18134-PROPOSED

Type III 24-hr 10 Yr 24 Hr +15% Rainfall=5.61"

Prepared by Jones & Beach Engineers Inc

Printed 4/19/2024

HydroCAD® 10.20-3c s/n 00762 © 2023 HydroCAD Software Solutions LLC

Page 6

Time span=0.00-24.00 hrs, dt=0.05 hrs, 481 points x 3
 Runoff by SCS TR-20 method, UH=SCS, Weighted-CN
 Reach routing by Dyn-Stor-Ind method - Pond routing by Dyn-Stor-Ind method

Subcatchment1S: Subcatchment1S	Runoff Area=7,392 sf 50.61% Impervious Runoff Depth>3.43" Flow Length=186' Tc=6.0 min CN=80 Runoff=0.67 cfs 0.048 af
Subcatchment2S: Subcatchment2S	Runoff Area=1,728 sf 0.00% Impervious Runoff Depth>1.75" Flow Length=20' Slope=0.0500 '/' Tc=6.0 min CN=61 Runoff=0.08 cfs 0.006 af
Subcatchment3S: Subcatchment3S	Runoff Area=45,177 sf 1.54% Impervious Runoff Depth>1.74" Flow Length=291' Tc=17.0 min CN=61 Runoff=1.42 cfs 0.151 af
Subcatchment4S: Subcatchment4S	Runoff Area=20,991 sf 8.04% Impervious Runoff Depth>1.99" Flow Length=210' Tc=7.9 min CN=64 Runoff=1.00 cfs 0.080 af
Subcatchment6S: Subcatchment6S	Runoff Area=1,952 sf 100.00% Impervious Runoff Depth>5.37" Tc=6.0 min CN=98 Runoff=0.24 cfs 0.020 af
Subcatchment7S: Subcatchment7S	Runoff Area=1,516 sf 100.00% Impervious Runoff Depth>5.37" Tc=6.0 min CN=98 Runoff=0.19 cfs 0.016 af
Subcatchment8S: Subcatchment8S	Runoff Area=3,011 sf 100.00% Impervious Runoff Depth>5.37" Tc=6.0 min CN=98 Runoff=0.37 cfs 0.031 af
Subcatchment9S: Subcatchment9S	Runoff Area=325 sf 100.00% Impervious Runoff Depth>5.37" Tc=6.0 min CN=98 Runoff=0.04 cfs 0.003 af
Subcatchment10S: Subcatchment10S	Runoff Area=3,630 sf 29.12% Impervious Runoff Depth>2.67" Flow Length=142' Tc=6.3 min CN=72 Runoff=0.25 cfs 0.019 af
Subcatchment11S: Subcatchment11S	Runoff Area=4,571 sf 49.42% Impervious Runoff Depth>3.33" Flow Length=77' Slope=0.0396 '/' Tc=6.0 min CN=79 Runoff=0.40 cfs 0.029 af
Subcatchment12S: Subcatchment12S	Runoff Area=3,734 sf 35.30% Impervious Runoff Depth>2.86" Flow Length=51' Slope=0.0320 '/' Tc=6.0 min CN=74 Runoff=0.28 cfs 0.020 af
Subcatchment13S: Subcatchment13S	Runoff Area=876 sf 100.00% Impervious Runoff Depth>5.37" Tc=6.0 min CN=98 Runoff=0.11 cfs 0.009 af
Subcatchment14S: Subcatchment14S	Runoff Area=560 sf 100.00% Impervious Runoff Depth>5.37" Tc=6.0 min CN=98 Runoff=0.07 cfs 0.006 af
Subcatchment15S: Subcatchment15S	Runoff Area=876 sf 100.00% Impervious Runoff Depth>5.37" Tc=6.0 min CN=98 Runoff=0.11 cfs 0.009 af
Subcatchment18S: Subcatchment18S	Runoff Area=9,474 sf 14.12% Impervious Runoff Depth>2.15" Flow Length=58' Tc=6.0 min CN=66 Runoff=0.53 cfs 0.039 af
Reach 1R: Ditch on Tidewatch Property	Avg. Flow Depth=0.32' Max Vel=2.37 fps Inflow=1.47 cfs 0.200 af n=0.030 L=159.0' S=0.0189 '/' Capacity=18.18 cfs Outflow=1.47 cfs 0.199 af

18134-PROPOSED

Type III 24-hr 10 Yr 24 Hr +15% Rainfall=5.61"

Prepared by Jones & Beach Engineers Inc

Printed 4/19/2024

HydroCAD® 10.20-3c s/n 00762 © 2023 HydroCAD Software Solutions LLC

Page 7

Reach 2R: Flow through 3S	Avg. Flow Depth=0.00' Max Vel=0.00 fps Inflow=0.00 cfs 0.000 af n=0.030 L=81.0' S=0.3457 '/' Capacity=740.30 cfs Outflow=0.00 cfs 0.000 af
Reach 4R: Flow Through 3S	Avg. Flow Depth=0.02' Max Vel=0.98 fps Inflow=0.05 cfs 0.049 af n=0.030 L=220.0' S=0.0909 '/' Capacity=66.79 cfs Outflow=0.05 cfs 0.049 af
Reach AP1: Analysis Point 1	Inflow=0.67 cfs 0.048 af Outflow=0.67 cfs 0.048 af
Reach AP2: Analysis Point 2	Inflow=0.08 cfs 0.006 af Outflow=0.08 cfs 0.006 af
Reach AP3: Analysis Point 3	Inflow=2.12 cfs 0.279 af Outflow=2.12 cfs 0.279 af
Pond 1P: Bioretention Pond	Peak Elev=62.21' Storage=3,721 cf Inflow=2.30 cfs 0.177 af Discarded=0.10 cfs 0.106 af Primary=0.05 cfs 0.049 af Outflow=0.15 cfs 0.155 af
Pond 2P: Stone Drip Edge	Peak Elev=65.98' Storage=0.006 af Inflow=0.11 cfs 0.009 af Discarded=0.00 cfs 0.004 af Secondary=0.00 cfs 0.000 af Outflow=0.00 cfs 0.004 af
Pond 3P: Stone Under Deck	Peak Elev=65.97' Storage=0.003 af Inflow=0.07 cfs 0.006 af Discarded=0.00 cfs 0.004 af Secondary=0.00 cfs 0.000 af Outflow=0.00 cfs 0.004 af
Pond 4P: Stone Drip Edge	Peak Elev=64.56' Storage=0.005 af Inflow=0.11 cfs 0.009 af Discarded=0.01 cfs 0.006 af Secondary=0.00 cfs 0.000 af Outflow=0.01 cfs 0.006 af
Pond CB101: Catch Basin 101	Peak Elev=62.78' Inflow=0.49 cfs 0.039 af 12.0" Round Culvert n=0.012 L=19.0' S=0.0053 '/' Outflow=0.49 cfs 0.039 af
Pond CB102: Catch Basin 102	Peak Elev=62.63' Inflow=0.68 cfs 0.054 af 12.0" Round Culvert n=0.012 L=147.0' S=0.0054 '/' Outflow=0.68 cfs 0.054 af
Pond CB103: Catch Basin 103	Peak Elev=66.91' Inflow=1.05 cfs 0.080 af 12.0" Round Culvert n=0.012 L=43.0' S=0.0070 '/' Outflow=1.05 cfs 0.080 af
Pond CB104: Catch Basin 104	Peak Elev=62.21' Inflow=1.77 cfs 0.138 af 12.0" Round Culvert n=0.012 L=45.0' S=0.0067 '/' Outflow=1.77 cfs 0.138 af
Pond YD1: Yard Drain 1	Peak Elev=63.12' Inflow=0.25 cfs 0.019 af 8.0" Round Culvert n=0.012 L=9.0' S=0.0189 '/' Outflow=0.25 cfs 0.019 af
Pond YD2: Yard Drain 2	Peak Elev=67.52' Inflow=0.40 cfs 0.029 af 8.0" Round Culvert n=0.012 L=52.0' S=0.0058 '/' Outflow=0.40 cfs 0.029 af
Pond YD3: Yard Drain 3	Peak Elev=68.34' Inflow=0.28 cfs 0.020 af 8.0" Round Culvert n=0.012 L=13.0' S=0.0923 '/' Outflow=0.28 cfs 0.020 af

Total Runoff Area = 2.429 ac Runoff Volume = 0.485 af Average Runoff Depth = 2.40"
79.95% Pervious = 1.942 ac 20.05% Impervious = 0.487 ac

18134-PROPOSED

Type III 24-hr 10 Yr 24 Hr +15% Rainfall=5.61"

Prepared by Jones & Beach Engineers Inc

Printed 4/19/2024

HydroCAD® 10.20-3c s/n 00762 © 2023 HydroCAD Software Solutions LLC

Page 8

Summary for Subcatchment 1S: Subcatchment 1S

Runoff = 0.67 cfs @ 12.09 hrs, Volume= 0.048 af, Depth> 3.43"
 Routed to Reach AP1 : Analysis Point 1

Runoff by SCS TR-20 method, UH=SCS, Weighted-CN, Time Span= 0.00-24.00 hrs, dt= 0.05 hrs
 Type III 24-hr 10 Yr 24 Hr +15% Rainfall=5.61"

Area (sf)	CN	Description
3,741	98	Paved parking, HSG B
3,651	61	>75% Grass cover, Good, HSG B
7,392	80	Weighted Average
3,651		49.39% Pervious Area
3,741		50.61% Impervious Area

Tc (min)	Length (feet)	Slope (ft/ft)	Velocity (ft/sec)	Capacity (cfs)	Description
2.8	56	0.1250	0.34		Sheet Flow, Grass: Short n= 0.150 P2= 3.70"
2.1	30	0.0670	0.23		Sheet Flow, Grass: Short n= 0.150 P2= 3.70"
0.2	14	0.0360	1.26		Sheet Flow, Smooth surfaces n= 0.011 P2= 3.70"
0.4	86	0.0360	3.85		Shallow Concentrated Flow, Paved Kv= 20.3 fps
5.5	186	Total, Increased to minimum Tc = 6.0 min			

Summary for Subcatchment 2S: Subcatchment 2S

Runoff = 0.08 cfs @ 12.10 hrs, Volume= 0.006 af, Depth> 1.75"
 Routed to Reach AP2 : Analysis Point 2

Runoff by SCS TR-20 method, UH=SCS, Weighted-CN, Time Span= 0.00-24.00 hrs, dt= 0.05 hrs
 Type III 24-hr 10 Yr 24 Hr +15% Rainfall=5.61"

Area (sf)	CN	Description
1,728	61	>75% Grass cover, Good, HSG B
1,728		100.00% Pervious Area

Tc (min)	Length (feet)	Slope (ft/ft)	Velocity (ft/sec)	Capacity (cfs)	Description
1.7	20	0.0500	0.19		Sheet Flow, Grass: Short n= 0.150 P2= 3.70"
1.7	20	Total, Increased to minimum Tc = 6.0 min			

18134-PROPOSED

Type III 24-hr 10 Yr 24 Hr +15% Rainfall=5.61"

Prepared by Jones & Beach Engineers Inc

Printed 4/19/2024

HydroCAD® 10.20-3c s/n 00762 © 2023 HydroCAD Software Solutions LLC

Page 9

Summary for Subcatchment 3S: Subcatchment 3S

Runoff = 1.42 cfs @ 12.26 hrs, Volume= 0.151 af, Depth> 1.74"

Routed to Reach 1R : Ditch on Tidewatch Property

Runoff by SCS TR-20 method, UH=SCS, Weighted-CN, Time Span= 0.00-24.00 hrs, dt= 0.05 hrs
Type III 24-hr 10 Yr 24 Hr +15% Rainfall=5.61"

Area (sf)	CN	Description
695	98	Roofs, HSG B
16,659	61	>75% Grass cover, Good, HSG B
27,823	60	Woods, Fair, HSG B
45,177	61	Weighted Average
44,482		98.46% Pervious Area
695		1.54% Impervious Area

Tc (min)	Length (feet)	Slope (ft/ft)	Velocity (ft/sec)	Capacity (cfs)	Description
9.0	53	0.0415	0.10		Sheet Flow, Woods: Light underbrush n= 0.400 P2= 3.70"
5.8	47	0.0968	0.13		Sheet Flow, Woods: Light underbrush n= 0.400 P2= 3.70"
0.2	15	0.0968	1.56		Shallow Concentrated Flow, Woodland Kv= 5.0 fps
0.7	54	0.0741	1.36		Shallow Concentrated Flow, Woodland Kv= 5.0 fps
1.3	122	0.1000	1.58		Shallow Concentrated Flow, Woodland Kv= 5.0 fps
17.0	291	Total			

Summary for Subcatchment 4S: Subcatchment 4S

Runoff = 1.00 cfs @ 12.12 hrs, Volume= 0.080 af, Depth> 1.99"

Routed to Reach AP3 : Analysis Point 3

Runoff by SCS TR-20 method, UH=SCS, Weighted-CN, Time Span= 0.00-24.00 hrs, dt= 0.05 hrs
Type III 24-hr 10 Yr 24 Hr +15% Rainfall=5.61"

Area (sf)	CN	Description
11,135	61	>75% Grass cover, Good, HSG B
8,169	60	Woods, Fair, HSG B
1,687	98	Roofs, HSG B
20,991	64	Weighted Average
19,304		91.96% Pervious Area
1,687		8.04% Impervious Area

18134-PROPOSED

Type III 24-hr 10 Yr 24 Hr +15% Rainfall=5.61"

Prepared by Jones & Beach Engineers Inc

Printed 4/19/2024

HydroCAD® 10.20-3c s/n 00762 © 2023 HydroCAD Software Solutions LLC

Page 10

Tc (min)	Length (feet)	Slope (ft/ft)	Velocity (ft/sec)	Capacity (cfs)	Description
1.5	14	0.0357	0.16		Sheet Flow, Grass: Short n= 0.150 P2= 3.70"
1.9	14	0.1429	0.12		Sheet Flow, Woods: Light underbrush n= 0.400 P2= 3.70"
3.3	72	0.1333	0.37		Sheet Flow, Grass: Short n= 0.150 P2= 3.70"
1.0	80	0.0750	1.37		Shallow Concentrated Flow, Woodland Kv= 5.0 fps
0.2	30	0.2667	2.58		Shallow Concentrated Flow, Woodland Kv= 5.0 fps
7.9	210	Total			

Summary for Subcatchment 6S: Subcatchment 6S

Runoff = 0.24 cfs @ 12.09 hrs, Volume= 0.020 af, Depth> 5.37"
Routed to Pond CB101 : Catch Basin 101

Runoff by SCS TR-20 method, UH=SCS, Weighted-CN, Time Span= 0.00-24.00 hrs, dt= 0.05 hrs
Type III 24-hr 10 Yr 24 Hr +15% Rainfall=5.61"

Area (sf)	CN	Description
1,952	98	Paved parking, HSG B
1,952		100.00% Impervious Area

Tc (min)	Length (feet)	Slope (ft/ft)	Velocity (ft/sec)	Capacity (cfs)	Description
6.0					Direct Entry,

Summary for Subcatchment 7S: Subcatchment 7S

Runoff = 0.19 cfs @ 12.09 hrs, Volume= 0.016 af, Depth> 5.37"
Routed to Pond CB102 : Catch Basin 102

Runoff by SCS TR-20 method, UH=SCS, Weighted-CN, Time Span= 0.00-24.00 hrs, dt= 0.05 hrs
Type III 24-hr 10 Yr 24 Hr +15% Rainfall=5.61"

Area (sf)	CN	Description
1,516	98	Paved parking, HSG B
1,516		100.00% Impervious Area

Tc (min)	Length (feet)	Slope (ft/ft)	Velocity (ft/sec)	Capacity (cfs)	Description
6.0					Direct Entry,

18134-PROPOSED

Type III 24-hr 10 Yr 24 Hr +15% Rainfall=5.61"

Prepared by Jones & Beach Engineers Inc

Printed 4/19/2024

HydroCAD® 10.20-3c s/n 00762 © 2023 HydroCAD Software Solutions LLC

Page 11

Summary for Subcatchment 8S: Subcatchment 8S

Runoff = 0.37 cfs @ 12.09 hrs, Volume= 0.031 af, Depth> 5.37"
 Routed to Pond CB103 : Catch Basin 103

Runoff by SCS TR-20 method, UH=SCS, Weighted-CN, Time Span= 0.00-24.00 hrs, dt= 0.05 hrs
 Type III 24-hr 10 Yr 24 Hr +15% Rainfall=5.61"

Area (sf)	CN	Description
2,554	98	Paved parking, HSG B
457	98	Roofs, HSG B
3,011	98	Weighted Average
3,011		100.00% Impervious Area

Tc (min)	Length (feet)	Slope (ft/ft)	Velocity (ft/sec)	Capacity (cfs)	Description
6.0					Direct Entry,

Summary for Subcatchment 9S: Subcatchment 9S

Runoff = 0.04 cfs @ 12.09 hrs, Volume= 0.003 af, Depth> 5.37"
 Routed to Pond CB104 : Catch Basin 104

Runoff by SCS TR-20 method, UH=SCS, Weighted-CN, Time Span= 0.00-24.00 hrs, dt= 0.05 hrs
 Type III 24-hr 10 Yr 24 Hr +15% Rainfall=5.61"

Area (sf)	CN	Description
325	98	Paved parking, HSG B
325		100.00% Impervious Area

Tc (min)	Length (feet)	Slope (ft/ft)	Velocity (ft/sec)	Capacity (cfs)	Description
6.0					Direct Entry,

Summary for Subcatchment 10S: Subcatchment 10S

Runoff = 0.25 cfs @ 12.10 hrs, Volume= 0.019 af, Depth> 2.67"
 Routed to Pond YD1 : Yard Drain 1

Runoff by SCS TR-20 method, UH=SCS, Weighted-CN, Time Span= 0.00-24.00 hrs, dt= 0.05 hrs
 Type III 24-hr 10 Yr 24 Hr +15% Rainfall=5.61"

Area (sf)	CN	Description
796	98	Roofs, HSG B
2,573	61	>75% Grass cover, Good, HSG B
261	98	Paved parking, HSG B
3,630	72	Weighted Average
2,573		70.88% Pervious Area
1,057		29.12% Impervious Area

18134-PROPOSED

Type III 24-hr 10 Yr 24 Hr +15% Rainfall=5.61"

Prepared by Jones & Beach Engineers Inc

Printed 4/19/2024

HydroCAD® 10.20-3c s/n 00762 © 2023 HydroCAD Software Solutions LLC

Page 12

Tc (min)	Length (feet)	Slope (ft/ft)	Velocity (ft/sec)	Capacity (cfs)	Description
2.2	42	0.1190	0.31		Sheet Flow, Grass: Short n= 0.150 P2= 3.70"
3.7	58	0.0650	0.26		Sheet Flow, Grass: Short n= 0.150 P2= 3.70"
0.4	42	0.0650	1.78		Shallow Concentrated Flow, Short Grass Pasture Kv= 7.0 fps
6.3	142	Total			

Summary for Subcatchment 11S: Subcatchment 11S

Runoff = 0.40 cfs @ 12.09 hrs, Volume= 0.029 af, Depth> 3.33"
Routed to Pond YD2 : Yard Drain 2

Runoff by SCS TR-20 method, UH=SCS, Weighted-CN, Time Span= 0.00-24.00 hrs, dt= 0.05 hrs
Type III 24-hr 10 Yr 24 Hr +15% Rainfall=5.61"

Area (sf)	CN	Description
1,998	98	Roofs, HSG B
2,312	61	>75% Grass cover, Good, HSG B
261	98	Paved parking, HSG B
4,571	79	Weighted Average
2,312		50.58% Pervious Area
2,259		49.42% Impervious Area

Tc (min)	Length (feet)	Slope (ft/ft)	Velocity (ft/sec)	Capacity (cfs)	Description
5.6	77	0.0396	0.23		Sheet Flow, Grass: Short n= 0.150 P2= 3.70"
5.6	77	Total, Increased to minimum Tc = 6.0 min			

Summary for Subcatchment 12S: Subcatchment 12S

Runoff = 0.28 cfs @ 12.09 hrs, Volume= 0.020 af, Depth> 2.86"
Routed to Pond YD3 : Yard Drain 3

Runoff by SCS TR-20 method, UH=SCS, Weighted-CN, Time Span= 0.00-24.00 hrs, dt= 0.05 hrs
Type III 24-hr 10 Yr 24 Hr +15% Rainfall=5.61"

Area (sf)	CN	Description
1,318	98	Roofs, HSG B
2,416	61	>75% Grass cover, Good, HSG B
3,734	74	Weighted Average
2,416		64.70% Pervious Area
1,318		35.30% Impervious Area

18134-PROPOSED

Type III 24-hr 10 Yr 24 Hr +15% Rainfall=5.61"

Prepared by Jones & Beach Engineers Inc

Printed 4/19/2024

HydroCAD® 10.20-3c s/n 00762 © 2023 HydroCAD Software Solutions LLC

Page 13

Tc (min)	Length (feet)	Slope (ft/ft)	Velocity (ft/sec)	Capacity (cfs)	Description
4.4	51	0.0320	0.19		Sheet Flow, Grass: Short n= 0.150 P2= 3.70"
4.4	51	Total, Increased to minimum Tc = 6.0 min			

Summary for Subcatchment 13S: Subcatchment 13S

Runoff = 0.11 cfs @ 12.09 hrs, Volume= 0.009 af, Depth> 5.37"
Routed to Pond 2P : Stone Drip Edge

Runoff by SCS TR-20 method, UH=SCS, Weighted-CN, Time Span= 0.00-24.00 hrs, dt= 0.05 hrs
Type III 24-hr 10 Yr 24 Hr +15% Rainfall=5.61"

Area (sf)	CN	Description
696	98	Roofs, HSG B
180	98	Water Surface, HSG B
876	98	Weighted Average
876		100.00% Impervious Area

Tc (min)	Length (feet)	Slope (ft/ft)	Velocity (ft/sec)	Capacity (cfs)	Description
6.0					Direct Entry,

Summary for Subcatchment 14S: Subcatchment 14S

Runoff = 0.07 cfs @ 12.09 hrs, Volume= 0.006 af, Depth> 5.37"
Routed to Pond 3P : Stone Under Deck

Runoff by SCS TR-20 method, UH=SCS, Weighted-CN, Time Span= 0.00-24.00 hrs, dt= 0.05 hrs
Type III 24-hr 10 Yr 24 Hr +15% Rainfall=5.61"

Area (sf)	CN	Description
560	98	Roofs, HSG B
560		100.00% Impervious Area

Tc (min)	Length (feet)	Slope (ft/ft)	Velocity (ft/sec)	Capacity (cfs)	Description
6.0					Direct Entry,

Summary for Subcatchment 15S: Subcatchment 15S

Runoff = 0.11 cfs @ 12.09 hrs, Volume= 0.009 af, Depth> 5.37"
Routed to Pond 4P : Stone Drip Edge

Runoff by SCS TR-20 method, UH=SCS, Weighted-CN, Time Span= 0.00-24.00 hrs, dt= 0.05 hrs
Type III 24-hr 10 Yr 24 Hr +15% Rainfall=5.61"

18134-PROPOSED

Type III 24-hr 10 Yr 24 Hr +15% Rainfall=5.61"

Prepared by Jones & Beach Engineers Inc

Printed 4/19/2024

HydroCAD® 10.20-3c s/n 00762 © 2023 HydroCAD Software Solutions LLC

Page 14

Area (sf)	CN	Description
696	98	Roofs, HSG B
180	98	Water Surface, HSG B
876	98	Weighted Average
876		100.00% Impervious Area

Tc (min)	Length (feet)	Slope (ft/ft)	Velocity (ft/sec)	Capacity (cfs)	Description
6.0					Direct Entry,

Summary for Subcatchment 18S: Subcatchment 18S

Runoff = 0.53 cfs @ 12.10 hrs, Volume= 0.039 af, Depth> 2.15"
 Routed to Pond 1P : Bioretention Pond

Runoff by SCS TR-20 method, UH=SCS, Weighted-CN, Time Span= 0.00-24.00 hrs, dt= 0.05 hrs
 Type III 24-hr 10 Yr 24 Hr +15% Rainfall=5.61"

Area (sf)	CN	Description
8,136	61	>75% Grass cover, Good, HSG B
938	98	Roofs, HSG B
400	98	Paved parking, HSG B
9,474	66	Weighted Average
8,136		85.88% Pervious Area
1,338		14.12% Impervious Area

Tc (min)	Length (feet)	Slope (ft/ft)	Velocity (ft/sec)	Capacity (cfs)	Description
2.5	43	0.0930	0.29		Sheet Flow, Grass: Short n= 0.150 P2= 3.70"
0.6	15	0.3333	0.39		Sheet Flow, Grass: Short n= 0.150 P2= 3.70"
3.1	58	Total, Increased to minimum Tc = 6.0 min			

Summary for Reach 1R: Ditch on Tidewatch Property

[62] Hint: Exceeded Reach 2R OUTLET depth by 0.32' @ 12.25 hrs

[62] Hint: Exceeded Reach 4R OUTLET depth by 0.30' @ 12.25 hrs

Inflow Area = 1.685 ac, 18.36% Impervious, Inflow Depth > 1.42" for 10 Yr 24 Hr +15% event
 Inflow = 1.47 cfs @ 12.26 hrs, Volume= 0.200 af
 Outflow = 1.47 cfs @ 12.27 hrs, Volume= 0.199 af, Atten= 0%, Lag= 0.8 min
 Routed to Reach AP3 : Analysis Point 3

Routing by Dyn-Stor-Ind method, Time Span= 0.00-24.00 hrs, dt= 0.05 hrs / 3
 Max. Velocity= 2.37 fps, Min. Travel Time= 1.1 min
 Avg. Velocity = 1.12 fps, Avg. Travel Time= 2.4 min

18134-PROPOSED

Type III 24-hr 10 Yr 24 Hr +15% Rainfall=5.61"

Prepared by Jones & Beach Engineers Inc

Printed 4/19/2024

HydroCAD® 10.20-3c s/n 00762 © 2023 HydroCAD Software Solutions LLC

Page 15

Peak Storage= 98 cf @ 12.27 hrs
Average Depth at Peak Storage= 0.32' , Surface Width= 2.90'
Bank-Full Depth= 1.00' Flow Area= 4.0 sf, Capacity= 18.18 cfs

1.00' x 1.00' deep channel, n= 0.030 Stream, clean & straight
Side Slope Z-value= 3.0 '/' Top Width= 7.00'
Length= 159.0' Slope= 0.0189 '/'
Inlet Invert= 38.00', Outlet Invert= 35.00'



Summary for Reach 2R: Flow through 3S

Inflow = 0.00 cfs @ 0.00 hrs, Volume= 0.000 af
Outflow = 0.00 cfs @ 0.00 hrs, Volume= 0.000 af, Atten= 0%, Lag= 0.0 min
Routed to Reach 1R : Ditch on Tidewatch Property

Routing by Dyn-Stor-Ind method, Time Span= 0.00-24.00 hrs, dt= 0.05 hrs / 3
Max. Velocity= 0.00 fps, Min. Travel Time= 0.0 min
Avg. Velocity = 0.00 fps, Avg. Travel Time= 0.0 min

Peak Storage= 0 cf @ 0.00 hrs
Average Depth at Peak Storage= 0.00'
Bank-Full Depth= 1.00' Flow Area= 33.3 sf, Capacity= 740.30 cfs

50.00' x 1.00' deep Parabolic Channel, n= 0.030 Stream, clean & straight
Length= 81.0' Slope= 0.3457 '/'
Inlet Invert= 66.00', Outlet Invert= 38.00'



‡

Summary for Reach 4R: Flow Through 3S

Inflow Area = 0.648 ac, 45.28% Impervious, Inflow Depth > 0.92" for 10 Yr 24 Hr +15% event
Inflow = 0.05 cfs @ 13.96 hrs, Volume= 0.049 af
Outflow = 0.05 cfs @ 14.00 hrs, Volume= 0.049 af, Atten= 0%, Lag= 2.5 min
Routed to Reach 1R : Ditch on Tidewatch Property

18134-PROPOSED

Type III 24-hr 10 Yr 24 Hr +15% Rainfall=5.61"

Prepared by Jones & Beach Engineers Inc

Printed 4/19/2024

HydroCAD® 10.20-3c s/n 00762 © 2023 HydroCAD Software Solutions LLC

Page 16

Routing by Dyn-Stor-Ind method, Time Span= 0.00-24.00 hrs, dt= 0.05 hrs / 3

Max. Velocity= 0.98 fps, Min. Travel Time= 3.7 min

Avg. Velocity = 0.92 fps, Avg. Travel Time= 4.0 min

Peak Storage= 11 cf @ 14.00 hrs

Average Depth at Peak Storage= 0.02' , Surface Width= 3.10'

Bank-Full Depth= 1.00' Flow Area= 6.0 sf, Capacity= 66.79 cfs

3.00' x 1.00' deep channel, n= 0.030 Stream, clean & straight

Side Slope Z-value= 3.0 '/' Top Width= 9.00'

Length= 220.0' Slope= 0.0909 '/'

Inlet Invert= 58.00', Outlet Invert= 38.00'

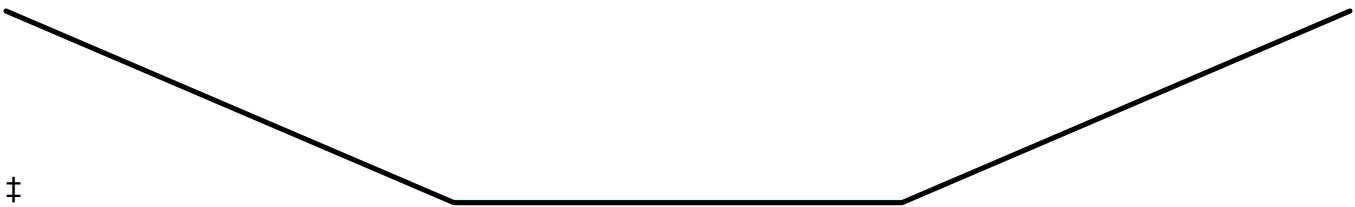

Summary for Reach AP1: Analysis Point 1

[40] Hint: Not Described (Outflow=Inflow)

Inflow Area = 0.170 ac, 50.61% Impervious, Inflow Depth > 3.43" for 10 Yr 24 Hr +15% event

Inflow = 0.67 cfs @ 12.09 hrs, Volume= 0.048 af

Outflow = 0.67 cfs @ 12.09 hrs, Volume= 0.048 af, Atten= 0%, Lag= 0.0 min

Routing by Dyn-Stor-Ind method, Time Span= 0.00-24.00 hrs, dt= 0.05 hrs / 3

Summary for Reach AP2: Analysis Point 2

[40] Hint: Not Described (Outflow=Inflow)

Inflow Area = 0.040 ac, 0.00% Impervious, Inflow Depth > 1.75" for 10 Yr 24 Hr +15% event

Inflow = 0.08 cfs @ 12.10 hrs, Volume= 0.006 af

Outflow = 0.08 cfs @ 12.10 hrs, Volume= 0.006 af, Atten= 0%, Lag= 0.0 min

Routing by Dyn-Stor-Ind method, Time Span= 0.00-24.00 hrs, dt= 0.05 hrs / 3

Summary for Reach AP3: Analysis Point 3

[40] Hint: Not Described (Outflow=Inflow)

Inflow Area = 2.167 ac, 16.06% Impervious, Inflow Depth > 1.55" for 10 Yr 24 Hr +15% event

Inflow = 2.12 cfs @ 12.22 hrs, Volume= 0.279 af

Outflow = 2.12 cfs @ 12.22 hrs, Volume= 0.279 af, Atten= 0%, Lag= 0.0 min

18134-PROPOSED

Type III 24-hr 10 Yr 24 Hr +15% Rainfall=5.61"

Prepared by Jones & Beach Engineers Inc

Printed 4/19/2024

HydroCAD® 10.20-3c s/n 00762 © 2023 HydroCAD Software Solutions LLC

Page 17

Routing by Dyn-Stor-Ind method, Time Span= 0.00-24.00 hrs, dt= 0.05 hrs / 3

Summary for Pond 1P: Bioretention Pond

Existing high contour within footprint of filter course = 61.0, SHWT depth = 35" per TP 10, so SHWT El. = 58.08, which is 0.01' below the bottom of stone. However, in our experience, modelling the SHWT with such a small separation to the bottom of stone causes an unrealistically high amount of infiltration to appear in the calculations. Therefore, the SHWT has been modelled 2" lower as a factor of safety.

Inflow Area = 0.648 ac, 45.28% Impervious, Inflow Depth > 3.28" for 10 Yr 24 Hr +15% event
 Inflow = 2.30 cfs @ 12.09 hrs, Volume= 0.177 af
 Outflow = 0.15 cfs @ 13.96 hrs, Volume= 0.155 af, Atten= 93%, Lag= 111.9 min
 Discarded = 0.10 cfs @ 13.96 hrs, Volume= 0.106 af
 Primary = 0.05 cfs @ 13.96 hrs, Volume= 0.049 af
 Routed to Reach 4R : Flow Through 3S

Routing by Dyn-Stor-Ind method, Time Span= 0.00-24.00 hrs, dt= 0.05 hrs / 3
 Peak Elev= 62.21' @ 13.96 hrs Surf.Area= 2,793 sf Storage= 3,721 cf

Plug-Flow detention time= 260.5 min calculated for 0.155 af (88% of inflow)
 Center-of-Mass det. time= 203.0 min (1,003.3 - 800.3)

Volume	Invert	Avail.Storage	Storage Description			
#1	58.09'	6,166 cf	Custom Stage Data (Irregular) Listed below (Recalc)			
Elevation (feet)	Surf.Area (sq-ft)	Perim. (feet)	Voids (%)	Inc.Store (cubic-feet)	Cum.Store (cubic-feet)	Wet.Area (sq-ft)
58.09	466	106.0	0.0	0	0	466
58.10	466	106.0	40.0	2	2	467
59.09	466	106.0	40.0	185	186	572
59.10	466	106.0	15.0	1	187	573
60.59	466	106.0	15.0	104	291	731
60.60	466	106.0	100.0	5	296	732
61.00	2,114	176.0	100.0	476	772	2,304
62.00	2,672	195.0	100.0	2,388	3,160	2,895
63.00	3,285	215.0	100.0	2,973	6,133	3,579
63.01	3,285	215.0	100.0	33	6,166	3,581

Device	Routing	Invert	Outlet Devices
#1	Primary	58.60'	12.0" Round Culvert L= 18.0' CPP, projecting, no headwall, Ke= 0.900 Inlet / Outlet Invert= 58.60' / 58.00' S= 0.0333 '/ Cc= 0.900 n= 0.012, Flow Area= 0.79 sf
#2	Device 1	58.90'	1.0" Vert. Orifice/Grate C= 0.600 Limited to weir flow at low heads
#3	Device 1	62.65'	15.0" Horiz. Orifice/Grate C= 0.600 Limited to weir flow at low heads
#4	Discarded	58.09'	0.300 in/hr Exfiltration over Surface area Conductivity to Groundwater Elevation = 57.92' Phase-In= 0.10'

18134-PROPOSED

Type III 24-hr 10 Yr 24 Hr +15% Rainfall=5.61"

Prepared by Jones & Beach Engineers Inc

Printed 4/19/2024

HydroCAD® 10.20-3c s/n 00762 © 2023 HydroCAD Software Solutions LLC

Page 18

Discarded OutFlow Max=0.10 cfs @ 13.96 hrs HW=62.21' (Free Discharge)

↑4=Exfiltration (Controls 0.10 cfs)

Primary OutFlow Max=0.05 cfs @ 13.96 hrs HW=62.21' TW=58.02' (Dynamic Tailwater)

↑1=Culvert (Passes 0.05 cfs of 5.26 cfs potential flow)

↑2=Orifice/Grate (Orifice Controls 0.05 cfs @ 8.70 fps)

↑3=Orifice/Grate (Controls 0.00 cfs)

Summary for Pond 2P: Stone Drip Edge

Ledge surface modelled 15" below original grade based on TP 1 and TP 4. Proposed grade is approximately 4' above existing grade and therefore 5.25' above ledge.

Inflow Area =	0.020 ac, 100.00% Impervious, Inflow Depth > 5.37"	for 10 Yr 24 Hr +15% event
Inflow =	0.11 cfs @ 12.09 hrs, Volume=	0.009 af
Outflow =	0.00 cfs @ 15.49 hrs, Volume=	0.004 af, Atten= 97%, Lag= 204.3 min
Discarded =	0.00 cfs @ 15.49 hrs, Volume=	0.004 af
Secondary =	0.00 cfs @ 0.00 hrs, Volume=	0.000 af

Routed to Reach 2R : Flow through 3S

Routing by Dyn-Stor-Ind method, Time Span= 0.00-24.00 hrs, dt= 0.05 hrs / 3
Peak Elev= 65.98' @ 15.49 hrs Surf.Area= 0.004 ac Storage= 0.006 af

Plug-Flow detention time= 332.3 min calculated for 0.004 af (50% of inflow)
Center-of-Mass det. time= 201.5 min (947.3 - 745.7)

Volume	Invert	Avail.Storage	Storage Description
#1	62.50'	0.006 af	3.00'W x 60.00'L x 3.51'H Prismatic 0.015 af Overall x 40.0% Voids

Device	Routing	Invert	Outlet Devices
#0	Secondary	66.01'	Automatic Storage Overflow (Discharged without head)
#1	Discarded	62.50'	0.300 in/hr Exfiltration over Surface area Conductivity to Groundwater Elevation = 60.75' Phase-In= 0.10'

Discarded OutFlow Max=0.00 cfs @ 15.49 hrs HW=65.98' (Free Discharge)

↑1=Exfiltration (Controls 0.00 cfs)

Secondary OutFlow Max=0.00 cfs @ 0.00 hrs HW=62.50' TW=66.00' (Dynamic Tailwater)

Summary for Pond 3P: Stone Under Deck

Ledge surface modelled 15" below original grade based on TP 1 and TP 4. Proposed grade is approximately 3.2' above existing grade and therefore 4.45' above ledge.

18134-PROPOSED

Type III 24-hr 10 Yr 24 Hr +15% Rainfall=5.61"

Prepared by Jones & Beach Engineers Inc

Printed 4/19/2024

HydroCAD® 10.20-3c s/n 00762 © 2023 HydroCAD Software Solutions LLC

Page 19

Inflow Area = 0.013 ac, 100.00% Impervious, Inflow Depth > 5.37" for 10 Yr 24 Hr +15% event
 Inflow = 0.07 cfs @ 12.09 hrs, Volume= 0.006 af
 Outflow = 0.00 cfs @ 15.02 hrs, Volume= 0.004 af, Atten= 96%, Lag= 176.3 min
 Discarded = 0.00 cfs @ 15.02 hrs, Volume= 0.004 af
 Secondary = 0.00 cfs @ 0.00 hrs, Volume= 0.000 af
 Routed to Reach 2R : Flow through 3S

Routing by Dyn-Stor-Ind method, Time Span= 0.00-24.00 hrs, dt= 0.05 hrs / 3
 Peak Elev= 65.97' @ 15.02 hrs Surf.Area= 0.006 ac Storage= 0.003 af

Plug-Flow detention time= 294.9 min calculated for 0.004 af (62% of inflow)
 Center-of-Mass det. time= 187.7 min (933.4 - 745.7)

Volume	Invert	Avail.Storage	Storage Description
#1	64.70'	0.004 af	14.00'W x 20.00'L x 1.50'H Prismaoid 0.010 af Overall x 40.0% Voids

Device	Routing	Invert	Outlet Devices
#0	Secondary	66.20'	Automatic Storage Overflow (Discharged without head)
#1	Discarded	64.70'	0.300 in/hr Exfiltration over Surface area Conductivity to Groundwater Elevation = 61.75' Phase-In= 0.10'

Discarded OutFlow Max=0.00 cfs @ 15.02 hrs HW=65.97' (Free Discharge)
 ↑**1=Exfiltration** (Controls 0.00 cfs)

Secondary OutFlow Max=0.00 cfs @ 0.00 hrs HW=64.70' TW=66.00' (Dynamic Tailwater)

Summary for Pond 4P: Stone Drip Edge

Ledge surface modelled 15" below original grade based on TP 1 and TP 4. Proposed grade is approximately 4' above existing grade and therefore 5.25' above ledge.

Inflow Area = 0.020 ac, 100.00% Impervious, Inflow Depth > 5.37" for 10 Yr 24 Hr +15% event
 Inflow = 0.11 cfs @ 12.09 hrs, Volume= 0.009 af
 Outflow = 0.01 cfs @ 13.80 hrs, Volume= 0.006 af, Atten= 94%, Lag= 103.0 min
 Discarded = 0.01 cfs @ 13.80 hrs, Volume= 0.006 af
 Secondary = 0.00 cfs @ 0.00 hrs, Volume= 0.000 af
 Routed to Reach 2R : Flow through 3S

Routing by Dyn-Stor-Ind method, Time Span= 0.00-24.00 hrs, dt= 0.05 hrs / 3
 Peak Elev= 64.56' @ 13.80 hrs Surf.Area= 0.004 ac Storage= 0.005 af

Plug-Flow detention time= 301.8 min calculated for 0.006 af (71% of inflow)
 Center-of-Mass det. time= 209.5 min (955.2 - 745.7)

Volume	Invert	Avail.Storage	Storage Description
#1	61.50'	0.007 af	3.00'W x 60.00'L x 4.51'H Prismaoid 0.019 af Overall x 40.0% Voids

18134-PROPOSED

Type III 24-hr 10 Yr 24 Hr +15% Rainfall=5.61"

Prepared by Jones & Beach Engineers Inc

Printed 4/19/2024

HydroCAD® 10.20-3c s/n 00762 © 2023 HydroCAD Software Solutions LLC

Page 20

Device	Routing	Invert	Outlet Devices
#0	Secondary	66.01'	Automatic Storage Overflow (Discharged without head)
#1	Discarded	61.50'	0.300 in/hr Exfiltration over Surface area Conductivity to Groundwater Elevation = 60.75' Phase-In= 0.10'

Discarded OutFlow Max=0.01 cfs @ 13.80 hrs HW=64.56' (Free Discharge)

↑1=Exfiltration (Controls 0.01 cfs)

Secondary OutFlow Max=0.00 cfs @ 0.00 hrs HW=61.50' TW=66.00' (Dynamic Tailwater)**Summary for Pond CB101: Catch Basin 101**

Inflow Area = 0.128 ac, 53.91% Impervious, Inflow Depth > 3.62" for 10 Yr 24 Hr +15% event
 Inflow = 0.49 cfs @ 12.09 hrs, Volume= 0.039 af
 Outflow = 0.49 cfs @ 12.09 hrs, Volume= 0.039 af, Atten= 0%, Lag= 0.0 min
 Primary = 0.49 cfs @ 12.09 hrs, Volume= 0.039 af
 Routed to Pond CB102 : Catch Basin 102

Routing by Dyn-Stor-Ind method, Time Span= 0.00-24.00 hrs, dt= 0.05 hrs / 3

Peak Elev= 62.78' @ 12.09 hrs

Flood Elev= 65.60'

Device	Routing	Invert	Outlet Devices
#1	Primary	62.30'	12.0" Round Culvert L= 19.0' CPP, projecting, no headwall, Ke= 0.900 Inlet / Outlet Invert= 62.30' / 62.20' S= 0.0053 '/' Cc= 0.900 n= 0.012, Flow Area= 0.79 sf

Primary OutFlow Max=0.48 cfs @ 12.09 hrs HW=62.77' TW=62.62' (Dynamic Tailwater)

↑1=Culvert (Outlet Controls 0.48 cfs @ 1.94 fps)

Summary for Pond CB102: Catch Basin 102

Inflow Area = 0.163 ac, 63.75% Impervious, Inflow Depth > 3.99" for 10 Yr 24 Hr +15% event
 Inflow = 0.68 cfs @ 12.09 hrs, Volume= 0.054 af
 Outflow = 0.68 cfs @ 12.09 hrs, Volume= 0.054 af, Atten= 0%, Lag= 0.0 min
 Primary = 0.68 cfs @ 12.09 hrs, Volume= 0.054 af
 Routed to Pond CB104 : Catch Basin 104

Routing by Dyn-Stor-Ind method, Time Span= 0.00-24.00 hrs, dt= 0.05 hrs / 3

Peak Elev= 62.63' @ 12.09 hrs

Flood Elev= 65.60'

Device	Routing	Invert	Outlet Devices
#1	Primary	62.10'	12.0" Round Culvert L= 147.0' CPP, projecting, no headwall, Ke= 0.900 Inlet / Outlet Invert= 62.10' / 61.30' S= 0.0054 '/' Cc= 0.900 n= 0.012, Flow Area= 0.79 sf

Primary OutFlow Max=0.67 cfs @ 12.09 hrs HW=62.62' TW=62.04' (Dynamic Tailwater)

↑1=Culvert (Outlet Controls 0.67 cfs @ 2.34 fps)

Summary for Pond CB103: Catch Basin 103

Inflow Area = 0.260 ac, 58.22% Impervious, Inflow Depth > 3.72" for 10 Yr 24 Hr +15% event
Inflow = 1.05 cfs @ 12.09 hrs, Volume= 0.080 af
Outflow = 1.05 cfs @ 12.09 hrs, Volume= 0.080 af, Atten= 0%, Lag= 0.0 min
Primary = 1.05 cfs @ 12.09 hrs, Volume= 0.080 af
Routed to Pond CB104 : Catch Basin 104

Routing by Dyn-Stor-Ind method, Time Span= 0.00-24.00 hrs, dt= 0.05 hrs / 3
Peak Elev= 66.91' @ 12.09 hrs
Flood Elev= 73.00'

Table with 4 columns: Device, Routing, Invert, Outlet Devices. Row 1: #1, Primary, 66.30', 12.0" Round Culvert. Includes details: L= 43.0' CPP, projecting, no headwall, Ke= 0.900, Inlet / Outlet Invert= 66.30' / 66.00', S= 0.0070 '/ Cc= 0.900, n= 0.012, Flow Area= 0.79 sf

Primary OutFlow Max=1.03 cfs @ 12.09 hrs HW=66.90' TW=62.04' (Dynamic Tailwater)
1=Culvert (Inlet Controls 1.03 cfs @ 2.09 fps)

Summary for Pond CB104: Catch Basin 104

Inflow Area = 0.430 ac, 61.04% Impervious, Inflow Depth > 3.85" for 10 Yr 24 Hr +15% event
Inflow = 1.77 cfs @ 12.09 hrs, Volume= 0.138 af
Outflow = 1.77 cfs @ 12.09 hrs, Volume= 0.138 af, Atten= 0%, Lag= 0.0 min
Primary = 1.77 cfs @ 12.09 hrs, Volume= 0.138 af
Routed to Pond 1P : Bioretention Pond

Routing by Dyn-Stor-Ind method, Time Span= 0.00-24.00 hrs, dt= 0.05 hrs / 3
Peak Elev= 62.21' @ 13.94 hrs
Flood Elev= 70.80'

Table with 4 columns: Device, Routing, Invert, Outlet Devices. Row 1: #1, Primary, 61.20', 12.0" Round Culvert. Includes details: L= 45.0' CPP, projecting, no headwall, Ke= 0.900, Inlet / Outlet Invert= 61.20' / 60.90', S= 0.0067 '/ Cc= 0.900, n= 0.012, Flow Area= 0.79 sf

Primary OutFlow Max=1.74 cfs @ 12.09 hrs HW=62.04' TW=61.45' (Dynamic Tailwater)
1=Culvert (Inlet Controls 1.74 cfs @ 2.46 fps)

Summary for Pond YD1: Yard Drain 1

Inflow Area = 0.083 ac, 29.12% Impervious, Inflow Depth > 2.67" for 10 Yr 24 Hr +15% event
Inflow = 0.25 cfs @ 12.10 hrs, Volume= 0.019 af
Outflow = 0.25 cfs @ 12.10 hrs, Volume= 0.019 af, Atten= 0%, Lag= 0.0 min
Primary = 0.25 cfs @ 12.10 hrs, Volume= 0.019 af
Routed to Pond CB101 : Catch Basin 101

Routing by Dyn-Stor-Ind method, Time Span= 0.00-24.00 hrs, dt= 0.05 hrs / 3

18134-PROPOSED

Type III 24-hr 10 Yr 24 Hr +15% Rainfall=5.61"

Prepared by Jones & Beach Engineers Inc

Printed 4/19/2024

HydroCAD® 10.20-3c s/n 00762 © 2023 HydroCAD Software Solutions LLC

Page 22

Peak Elev= 63.12' @ 12.10 hrs
Flood Elev= 65.80'

Device	Routing	Invert	Outlet Devices
#1	Primary	62.80'	8.0" Round Culvert L= 9.0' CPP, projecting, no headwall, Ke= 0.900 Inlet / Outlet Invert= 62.80' / 62.63' S= 0.0189 '/ Cc= 0.900 n= 0.012, Flow Area= 0.35 sf

Primary OutFlow Max=0.25 cfs @ 12.10 hrs HW=63.12' TW=62.78' (Dynamic Tailwater)
↑**1=Culvert** (Inlet Controls 0.25 cfs @ 1.52 fps)

Summary for Pond YD2: Yard Drain 2

Inflow Area = 0.105 ac, 49.42% Impervious, Inflow Depth > 3.33" for 10 Yr 24 Hr +15% event
Inflow = 0.40 cfs @ 12.09 hrs, Volume= 0.029 af
Outflow = 0.40 cfs @ 12.09 hrs, Volume= 0.029 af, Atten= 0%, Lag= 0.0 min
Primary = 0.40 cfs @ 12.09 hrs, Volume= 0.029 af
Routed to Pond CB103 : Catch Basin 103

Routing by Dyn-Stor-Ind method, Time Span= 0.00-24.00 hrs, dt= 0.05 hrs / 3
Peak Elev= 67.52' @ 12.09 hrs
Flood Elev= 69.30'

Device	Routing	Invert	Outlet Devices
#1	Primary	67.10'	8.0" Round Culvert L= 52.0' CPP, projecting, no headwall, Ke= 0.900 Inlet / Outlet Invert= 67.10' / 66.80' S= 0.0058 '/ Cc= 0.900 n= 0.012, Flow Area= 0.35 sf

Primary OutFlow Max=0.39 cfs @ 12.09 hrs HW=67.52' TW=66.90' (Dynamic Tailwater)
↑**1=Culvert** (Barrel Controls 0.39 cfs @ 2.43 fps)

Summary for Pond YD3: Yard Drain 3

Inflow Area = 0.086 ac, 35.30% Impervious, Inflow Depth > 2.86" for 10 Yr 24 Hr +15% event
Inflow = 0.28 cfs @ 12.09 hrs, Volume= 0.020 af
Outflow = 0.28 cfs @ 12.09 hrs, Volume= 0.020 af, Atten= 0%, Lag= 0.0 min
Primary = 0.28 cfs @ 12.09 hrs, Volume= 0.020 af
Routed to Pond CB103 : Catch Basin 103

Routing by Dyn-Stor-Ind method, Time Span= 0.00-24.00 hrs, dt= 0.05 hrs / 3
Peak Elev= 68.34' @ 12.09 hrs
Flood Elev= 70.20'

Device	Routing	Invert	Outlet Devices
#1	Primary	68.00'	8.0" Round Culvert L= 13.0' CPP, projecting, no headwall, Ke= 0.900 Inlet / Outlet Invert= 68.00' / 66.80' S= 0.0923 '/ Cc= 0.900 n= 0.012, Flow Area= 0.35 sf

18134-PROPOSED

Type III 24-hr 10 Yr 24 Hr +15% Rainfall=5.61"

Prepared by Jones & Beach Engineers Inc

Printed 4/19/2024

HydroCAD® 10.20-3c s/n 00762 © 2023 HydroCAD Software Solutions LLC

Page 23

Primary OutFlow Max=0.28 cfs @ 12.09 hrs HW=68.34' TW=66.90' (Dynamic Tailwater)

↑**1=Culvert** (Inlet Controls 0.28 cfs @ 1.56 fps)

18134-PROPOSED

Type III 24-hr 25 Yr 24 Hr +15% Rainfall=7.12"

Prepared by Jones & Beach Engineers Inc

Printed 4/19/2024

HydroCAD® 10.20-3c s/n 00762 © 2023 HydroCAD Software Solutions LLC

Page 24

Time span=0.00-24.00 hrs, dt=0.05 hrs, 481 points x 3
 Runoff by SCS TR-20 method, UH=SCS, Weighted-CN
 Reach routing by Dyn-Stor-Ind method - Pond routing by Dyn-Stor-Ind method

Subcatchment1S: Subcatchment1S	Runoff Area=7,392 sf 50.61% Impervious Runoff Depth>4.80" Flow Length=186' Tc=6.0 min CN=80 Runoff=0.93 cfs 0.068 af
Subcatchment2S: Subcatchment2S	Runoff Area=1,728 sf 0.00% Impervious Runoff Depth>2.79" Flow Length=20' Slope=0.0500 '/' Tc=6.0 min CN=61 Runoff=0.12 cfs 0.009 af
Subcatchment3S: Subcatchment3S	Runoff Area=45,177 sf 1.54% Impervious Runoff Depth>2.78" Flow Length=291' Tc=17.0 min CN=61 Runoff=2.36 cfs 0.240 af
Subcatchment4S: Subcatchment4S	Runoff Area=20,991 sf 8.04% Impervious Runoff Depth>3.09" Flow Length=210' Tc=7.9 min CN=64 Runoff=1.60 cfs 0.124 af
Subcatchment6S: Subcatchment6S	Runoff Area=1,952 sf 100.00% Impervious Runoff Depth>6.88" Tc=6.0 min CN=98 Runoff=0.31 cfs 0.026 af
Subcatchment7S: Subcatchment7S	Runoff Area=1,516 sf 100.00% Impervious Runoff Depth>6.88" Tc=6.0 min CN=98 Runoff=0.24 cfs 0.020 af
Subcatchment8S: Subcatchment8S	Runoff Area=3,011 sf 100.00% Impervious Runoff Depth>6.88" Tc=6.0 min CN=98 Runoff=0.47 cfs 0.040 af
Subcatchment9S: Subcatchment9S	Runoff Area=325 sf 100.00% Impervious Runoff Depth>6.88" Tc=6.0 min CN=98 Runoff=0.05 cfs 0.004 af
Subcatchment10S: Subcatchment10S	Runoff Area=3,630 sf 29.12% Impervious Runoff Depth>3.93" Flow Length=142' Tc=6.3 min CN=72 Runoff=0.37 cfs 0.027 af
Subcatchment11S: Subcatchment11S	Runoff Area=4,571 sf 49.42% Impervious Runoff Depth>4.69" Flow Length=77' Slope=0.0396 '/' Tc=6.0 min CN=79 Runoff=0.56 cfs 0.041 af
Subcatchment12S: Subcatchment12S	Runoff Area=3,734 sf 35.30% Impervious Runoff Depth>4.14" Flow Length=51' Slope=0.0320 '/' Tc=6.0 min CN=74 Runoff=0.41 cfs 0.030 af
Subcatchment13S: Subcatchment13S	Runoff Area=876 sf 100.00% Impervious Runoff Depth>6.88" Tc=6.0 min CN=98 Runoff=0.14 cfs 0.012 af
Subcatchment14S: Subcatchment14S	Runoff Area=560 sf 100.00% Impervious Runoff Depth>6.88" Tc=6.0 min CN=98 Runoff=0.09 cfs 0.007 af
Subcatchment15S: Subcatchment15S	Runoff Area=876 sf 100.00% Impervious Runoff Depth>6.88" Tc=6.0 min CN=98 Runoff=0.14 cfs 0.012 af
Subcatchment18S: Subcatchment18S	Runoff Area=9,474 sf 14.12% Impervious Runoff Depth>3.30" Flow Length=58' Tc=6.0 min CN=66 Runoff=0.82 cfs 0.060 af
Reach 1R: Ditch on Tidewatch Property	Avg. Flow Depth=0.40' Max Vel=2.71 fps Inflow=2.41 cfs 0.312 af n=0.030 L=159.0' S=0.0189 '/' Capacity=18.18 cfs Outflow=2.41 cfs 0.312 af

18134-PROPOSED

Type III 24-hr 25 Yr 24 Hr +15% Rainfall=7.12"

Prepared by Jones & Beach Engineers Inc

Printed 4/19/2024

HydroCAD® 10.20-3c s/n 00762 © 2023 HydroCAD Software Solutions LLC

Page 25

Reach 2R: Flow through 3S	Avg. Flow Depth=0.01' Max Vel=1.19 fps Inflow=0.05 cfs 0.003 af n=0.030 L=81.0' S=0.3457 '/' Capacity=740.30 cfs Outflow=0.05 cfs 0.003 af
Reach 4R: Flow Through 3S	Avg. Flow Depth=0.04' Max Vel=1.69 fps Inflow=0.21 cfs 0.070 af n=0.030 L=220.0' S=0.0909 '/' Capacity=66.79 cfs Outflow=0.21 cfs 0.070 af
Reach AP1: Analysis Point 1	Inflow=0.93 cfs 0.068 af Outflow=0.93 cfs 0.068 af
Reach AP2: Analysis Point 2	Inflow=0.12 cfs 0.009 af Outflow=0.12 cfs 0.009 af
Reach AP3: Analysis Point 3	Inflow=3.47 cfs 0.436 af Outflow=3.47 cfs 0.436 af
Pond 1P: Bioretention Pond	Peak Elev=62.70' Storage=5,186 cf Inflow=3.23 cfs 0.247 af Discarded=0.12 cfs 0.125 af Primary=0.21 cfs 0.070 af Outflow=0.33 cfs 0.195 af
Pond 2P: Stone Drip Edge	Peak Elev=66.01' Storage=0.006 af Inflow=0.14 cfs 0.012 af Discarded=0.00 cfs 0.005 af Secondary=0.05 cfs 0.002 af Outflow=0.05 cfs 0.007 af
Pond 3P: Stone Under Deck	Peak Elev=66.20' Storage=0.004 af Inflow=0.09 cfs 0.007 af Discarded=0.00 cfs 0.004 af Secondary=0.01 cfs 0.001 af Outflow=0.01 cfs 0.005 af
Pond 4P: Stone Drip Edge	Peak Elev=65.51' Storage=0.007 af Inflow=0.14 cfs 0.012 af Discarded=0.01 cfs 0.008 af Secondary=0.00 cfs 0.000 af Outflow=0.01 cfs 0.008 af
Pond CB101: Catch Basin 101	Peak Elev=62.92' Inflow=0.68 cfs 0.053 af 12.0" Round Culvert n=0.012 L=19.0' S=0.0053 '/' Outflow=0.68 cfs 0.053 af
Pond CB102: Catch Basin 102	Peak Elev=62.85' Inflow=0.92 cfs 0.073 af 12.0" Round Culvert n=0.012 L=147.0' S=0.0054 '/' Outflow=0.92 cfs 0.073 af
Pond CB103: Catch Basin 103	Peak Elev=67.04' Inflow=1.44 cfs 0.110 af 12.0" Round Culvert n=0.012 L=43.0' S=0.0070 '/' Outflow=1.44 cfs 0.110 af
Pond CB104: Catch Basin 104	Peak Elev=62.71' Inflow=2.41 cfs 0.187 af 12.0" Round Culvert n=0.012 L=45.0' S=0.0067 '/' Outflow=2.41 cfs 0.187 af
Pond YD1: Yard Drain 1	Peak Elev=63.20' Inflow=0.37 cfs 0.027 af 8.0" Round Culvert n=0.012 L=9.0' S=0.0189 '/' Outflow=0.37 cfs 0.027 af
Pond YD2: Yard Drain 2	Peak Elev=67.62' Inflow=0.56 cfs 0.041 af 8.0" Round Culvert n=0.012 L=52.0' S=0.0058 '/' Outflow=0.56 cfs 0.041 af
Pond YD3: Yard Drain 3	Peak Elev=68.42' Inflow=0.41 cfs 0.030 af 8.0" Round Culvert n=0.012 L=13.0' S=0.0923 '/' Outflow=0.41 cfs 0.030 af

Total Runoff Area = 2.429 ac Runoff Volume = 0.719 af Average Runoff Depth = 3.55"
79.95% Pervious = 1.942 ac 20.05% Impervious = 0.487 ac

18134-PROPOSED

Type III 24-hr 50 Yr 24 Hr +15% Rainfall=8.53"

Prepared by Jones & Beach Engineers Inc

Printed 4/19/2024

HydroCAD® 10.20-3c s/n 00762 © 2023 HydroCAD Software Solutions LLC

Page 26

Time span=0.00-24.00 hrs, dt=0.05 hrs, 481 points x 3
 Runoff by SCS TR-20 method, UH=SCS, Weighted-CN
 Reach routing by Dyn-Stor-Ind method - Pond routing by Dyn-Stor-Ind method

Subcatchment1S: Subcatchment1S	Runoff Area=7,392 sf 50.61% Impervious Runoff Depth>6.12" Flow Length=186' Tc=6.0 min CN=80 Runoff=1.17 cfs 0.087 af
Subcatchment2S: Subcatchment2S	Runoff Area=1,728 sf 0.00% Impervious Runoff Depth>3.85" Flow Length=20' Slope=0.0500 '/' Tc=6.0 min CN=61 Runoff=0.17 cfs 0.013 af
Subcatchment3S: Subcatchment3S	Runoff Area=45,177 sf 1.54% Impervious Runoff Depth>3.84" Flow Length=291' Tc=17.0 min CN=61 Runoff=3.32 cfs 0.332 af
Subcatchment4S: Subcatchment4S	Runoff Area=20,991 sf 8.04% Impervious Runoff Depth>4.20" Flow Length=210' Tc=7.9 min CN=64 Runoff=2.19 cfs 0.169 af
Subcatchment6S: Subcatchment6S	Runoff Area=1,952 sf 100.00% Impervious Runoff Depth>8.28" Tc=6.0 min CN=98 Runoff=0.37 cfs 0.031 af
Subcatchment7S: Subcatchment7S	Runoff Area=1,516 sf 100.00% Impervious Runoff Depth>8.28" Tc=6.0 min CN=98 Runoff=0.28 cfs 0.024 af
Subcatchment8S: Subcatchment8S	Runoff Area=3,011 sf 100.00% Impervious Runoff Depth>8.28" Tc=6.0 min CN=98 Runoff=0.57 cfs 0.048 af
Subcatchment9S: Subcatchment9S	Runoff Area=325 sf 100.00% Impervious Runoff Depth>8.28" Tc=6.0 min CN=98 Runoff=0.06 cfs 0.005 af
Subcatchment10S: Subcatchment10S	Runoff Area=3,630 sf 29.12% Impervious Runoff Depth>5.16" Flow Length=142' Tc=6.3 min CN=72 Runoff=0.49 cfs 0.036 af
Subcatchment11S: Subcatchment11S	Runoff Area=4,571 sf 49.42% Impervious Runoff Depth>6.00" Flow Length=77' Slope=0.0396 '/' Tc=6.0 min CN=79 Runoff=0.71 cfs 0.052 af
Subcatchment12S: Subcatchment12S	Runoff Area=3,734 sf 35.30% Impervious Runoff Depth>5.40" Flow Length=51' Slope=0.0320 '/' Tc=6.0 min CN=74 Runoff=0.53 cfs 0.039 af
Subcatchment13S: Subcatchment13S	Runoff Area=876 sf 100.00% Impervious Runoff Depth>8.28" Tc=6.0 min CN=98 Runoff=0.16 cfs 0.014 af
Subcatchment14S: Subcatchment14S	Runoff Area=560 sf 100.00% Impervious Runoff Depth>8.28" Tc=6.0 min CN=98 Runoff=0.11 cfs 0.009 af
Subcatchment15S: Subcatchment15S	Runoff Area=876 sf 100.00% Impervious Runoff Depth>8.28" Tc=6.0 min CN=98 Runoff=0.16 cfs 0.014 af
Subcatchment18S: Subcatchment18S	Runoff Area=9,474 sf 14.12% Impervious Runoff Depth>4.44" Flow Length=58' Tc=6.0 min CN=66 Runoff=1.11 cfs 0.081 af
Reach 1R: Ditch on Tidewatch Property	Avg. Flow Depth=0.51' Max Vel=3.08 fps Inflow=3.98 cfs 0.460 af n=0.030 L=159.0' S=0.0189 '/' Capacity=18.18 cfs Outflow=3.98 cfs 0.460 af

18134-PROPOSED

Type III 24-hr 50 Yr 24 Hr +15% Rainfall=8.53"

Prepared by Jones & Beach Engineers Inc

Printed 4/19/2024

HydroCAD® 10.20-3c s/n 00762 © 2023 HydroCAD Software Solutions LLC

Page 27

Reach 2R: Flow through 3S	Avg. Flow Depth=0.02' Max Vel=1.55 fps Inflow=0.12 cfs 0.006 af n=0.030 L=81.0' S=0.3457 '/' Capacity=740.30 cfs Outflow=0.12 cfs 0.006 af
Reach 4R: Flow Through 3S	Avg. Flow Depth=0.11' Max Vel=3.19 fps Inflow=1.18 cfs 0.122 af n=0.030 L=220.0' S=0.0909 '/' Capacity=66.79 cfs Outflow=1.17 cfs 0.122 af
Reach AP1: Analysis Point 1	Inflow=1.17 cfs 0.087 af Outflow=1.17 cfs 0.087 af
Reach AP2: Analysis Point 2	Inflow=0.17 cfs 0.013 af Outflow=0.17 cfs 0.013 af
Reach AP3: Analysis Point 3	Inflow=5.03 cfs 0.629 af Outflow=5.03 cfs 0.629 af
Pond 1P: Bioretention Pond	Peak Elev=62.85' Storage=5,639 cf Inflow=4.12 cfs 0.315 af Discarded=0.12 cfs 0.132 af Primary=1.18 cfs 0.122 af Outflow=1.30 cfs 0.254 af
Pond 2P: Stone Drip Edge	Peak Elev=66.01' Storage=0.006 af Inflow=0.16 cfs 0.014 af Discarded=0.00 cfs 0.005 af Secondary=0.11 cfs 0.004 af Outflow=0.11 cfs 0.009 af
Pond 3P: Stone Under Deck	Peak Elev=66.20' Storage=0.004 af Inflow=0.11 cfs 0.009 af Discarded=0.00 cfs 0.004 af Secondary=0.04 cfs 0.002 af Outflow=0.05 cfs 0.006 af
Pond 4P: Stone Drip Edge	Peak Elev=66.01' Storage=0.007 af Inflow=0.16 cfs 0.014 af Discarded=0.01 cfs 0.009 af Secondary=0.02 cfs 0.001 af Outflow=0.03 cfs 0.010 af
Pond CB101: Catch Basin 101	Peak Elev=63.28' Inflow=0.86 cfs 0.067 af 12.0" Round Culvert n=0.012 L=19.0' S=0.0053 '/' Outflow=0.86 cfs 0.067 af
Pond CB102: Catch Basin 102	Peak Elev=63.42' Inflow=1.14 cfs 0.091 af 12.0" Round Culvert n=0.012 L=147.0' S=0.0054 '/' Outflow=1.14 cfs 0.091 af
Pond CB103: Catch Basin 103	Peak Elev=67.16' Inflow=1.81 cfs 0.139 af 12.0" Round Culvert n=0.012 L=43.0' S=0.0070 '/' Outflow=1.81 cfs 0.139 af
Pond CB104: Catch Basin 104	Peak Elev=63.25' Inflow=3.01 cfs 0.235 af 12.0" Round Culvert n=0.012 L=45.0' S=0.0067 '/' Outflow=3.01 cfs 0.235 af
Pond YD1: Yard Drain 1	Peak Elev=63.50' Inflow=0.49 cfs 0.036 af 8.0" Round Culvert n=0.012 L=9.0' S=0.0189 '/' Outflow=0.49 cfs 0.036 af
Pond YD2: Yard Drain 2	Peak Elev=67.72' Inflow=0.71 cfs 0.052 af 8.0" Round Culvert n=0.012 L=52.0' S=0.0058 '/' Outflow=0.71 cfs 0.052 af
Pond YD3: Yard Drain 3	Peak Elev=68.50' Inflow=0.53 cfs 0.039 af 8.0" Round Culvert n=0.012 L=13.0' S=0.0923 '/' Outflow=0.53 cfs 0.039 af

Total Runoff Area = 2.429 ac Runoff Volume = 0.952 af Average Runoff Depth = 4.70"
79.95% Pervious = 1.942 ac 20.05% Impervious = 0.487 ac

18134-PROPOSED

Type III 24-hr 50 Yr 24 Hr +15% Rainfall=8.53"

Prepared by Jones & Beach Engineers Inc

Printed 4/19/2024

HydroCAD® 10.20-3c s/n 00762 © 2023 HydroCAD Software Solutions LLC

Page 28

Summary for Subcatchment 1S: Subcatchment 1S

Runoff = 1.17 cfs @ 12.09 hrs, Volume= 0.087 af, Depth> 6.12"
 Routed to Reach AP1 : Analysis Point 1

Runoff by SCS TR-20 method, UH=SCS, Weighted-CN, Time Span= 0.00-24.00 hrs, dt= 0.05 hrs
 Type III 24-hr 50 Yr 24 Hr +15% Rainfall=8.53"

Area (sf)	CN	Description
3,741	98	Paved parking, HSG B
3,651	61	>75% Grass cover, Good, HSG B
7,392	80	Weighted Average
3,651		49.39% Pervious Area
3,741		50.61% Impervious Area

Tc (min)	Length (feet)	Slope (ft/ft)	Velocity (ft/sec)	Capacity (cfs)	Description
2.8	56	0.1250	0.34		Sheet Flow, Grass: Short n= 0.150 P2= 3.70"
2.1	30	0.0670	0.23		Sheet Flow, Grass: Short n= 0.150 P2= 3.70"
0.2	14	0.0360	1.26		Sheet Flow, Smooth surfaces n= 0.011 P2= 3.70"
0.4	86	0.0360	3.85		Shallow Concentrated Flow, Paved Kv= 20.3 fps
5.5	186	Total, Increased to minimum Tc = 6.0 min			

Summary for Subcatchment 2S: Subcatchment 2S

Runoff = 0.17 cfs @ 12.10 hrs, Volume= 0.013 af, Depth> 3.85"
 Routed to Reach AP2 : Analysis Point 2

Runoff by SCS TR-20 method, UH=SCS, Weighted-CN, Time Span= 0.00-24.00 hrs, dt= 0.05 hrs
 Type III 24-hr 50 Yr 24 Hr +15% Rainfall=8.53"

Area (sf)	CN	Description
1,728	61	>75% Grass cover, Good, HSG B
1,728		100.00% Pervious Area

Tc (min)	Length (feet)	Slope (ft/ft)	Velocity (ft/sec)	Capacity (cfs)	Description
1.7	20	0.0500	0.19		Sheet Flow, Grass: Short n= 0.150 P2= 3.70"
1.7	20	Total, Increased to minimum Tc = 6.0 min			

18134-PROPOSED

Type III 24-hr 50 Yr 24 Hr +15% Rainfall=8.53"

Prepared by Jones & Beach Engineers Inc

Printed 4/19/2024

HydroCAD® 10.20-3c s/n 00762 © 2023 HydroCAD Software Solutions LLC

Page 29

Summary for Subcatchment 3S: Subcatchment 3S

Runoff = 3.32 cfs @ 12.24 hrs, Volume= 0.332 af, Depth> 3.84"

Routed to Reach 1R : Ditch on Tidewatch Property

Runoff by SCS TR-20 method, UH=SCS, Weighted-CN, Time Span= 0.00-24.00 hrs, dt= 0.05 hrs
Type III 24-hr 50 Yr 24 Hr +15% Rainfall=8.53"

Area (sf)	CN	Description
695	98	Roofs, HSG B
16,659	61	>75% Grass cover, Good, HSG B
27,823	60	Woods, Fair, HSG B
45,177	61	Weighted Average
44,482		98.46% Pervious Area
695		1.54% Impervious Area

Tc (min)	Length (feet)	Slope (ft/ft)	Velocity (ft/sec)	Capacity (cfs)	Description
9.0	53	0.0415	0.10		Sheet Flow, Woods: Light underbrush n= 0.400 P2= 3.70"
5.8	47	0.0968	0.13		Sheet Flow, Woods: Light underbrush n= 0.400 P2= 3.70"
0.2	15	0.0968	1.56		Shallow Concentrated Flow, Woodland Kv= 5.0 fps
0.7	54	0.0741	1.36		Shallow Concentrated Flow, Woodland Kv= 5.0 fps
1.3	122	0.1000	1.58		Shallow Concentrated Flow, Woodland Kv= 5.0 fps
17.0	291	Total			

Summary for Subcatchment 4S: Subcatchment 4S

Runoff = 2.19 cfs @ 12.12 hrs, Volume= 0.169 af, Depth> 4.20"

Routed to Reach AP3 : Analysis Point 3

Runoff by SCS TR-20 method, UH=SCS, Weighted-CN, Time Span= 0.00-24.00 hrs, dt= 0.05 hrs
Type III 24-hr 50 Yr 24 Hr +15% Rainfall=8.53"

Area (sf)	CN	Description
11,135	61	>75% Grass cover, Good, HSG B
8,169	60	Woods, Fair, HSG B
1,687	98	Roofs, HSG B
20,991	64	Weighted Average
19,304		91.96% Pervious Area
1,687		8.04% Impervious Area

18134-PROPOSED

Type III 24-hr 50 Yr 24 Hr +15% Rainfall=8.53"

Prepared by Jones & Beach Engineers Inc

Printed 4/19/2024

HydroCAD® 10.20-3c s/n 00762 © 2023 HydroCAD Software Solutions LLC

Page 30

Tc (min)	Length (feet)	Slope (ft/ft)	Velocity (ft/sec)	Capacity (cfs)	Description
1.5	14	0.0357	0.16		Sheet Flow, Grass: Short n= 0.150 P2= 3.70"
1.9	14	0.1429	0.12		Sheet Flow, Woods: Light underbrush n= 0.400 P2= 3.70"
3.3	72	0.1333	0.37		Sheet Flow, Grass: Short n= 0.150 P2= 3.70"
1.0	80	0.0750	1.37		Shallow Concentrated Flow, Woodland Kv= 5.0 fps
0.2	30	0.2667	2.58		Shallow Concentrated Flow, Woodland Kv= 5.0 fps
7.9	210	Total			

Summary for Subcatchment 6S: Subcatchment 6S

Runoff = 0.37 cfs @ 12.09 hrs, Volume= 0.031 af, Depth> 8.28"
Routed to Pond CB101 : Catch Basin 101

Runoff by SCS TR-20 method, UH=SCS, Weighted-CN, Time Span= 0.00-24.00 hrs, dt= 0.05 hrs
Type III 24-hr 50 Yr 24 Hr +15% Rainfall=8.53"

Area (sf)	CN	Description
1,952	98	Paved parking, HSG B
1,952		100.00% Impervious Area

Tc (min)	Length (feet)	Slope (ft/ft)	Velocity (ft/sec)	Capacity (cfs)	Description
6.0					Direct Entry,

Summary for Subcatchment 7S: Subcatchment 7S

Runoff = 0.28 cfs @ 12.09 hrs, Volume= 0.024 af, Depth> 8.28"
Routed to Pond CB102 : Catch Basin 102

Runoff by SCS TR-20 method, UH=SCS, Weighted-CN, Time Span= 0.00-24.00 hrs, dt= 0.05 hrs
Type III 24-hr 50 Yr 24 Hr +15% Rainfall=8.53"

Area (sf)	CN	Description
1,516	98	Paved parking, HSG B
1,516		100.00% Impervious Area

Tc (min)	Length (feet)	Slope (ft/ft)	Velocity (ft/sec)	Capacity (cfs)	Description
6.0					Direct Entry,

18134-PROPOSED

Type III 24-hr 50 Yr 24 Hr +15% Rainfall=8.53"

Prepared by Jones & Beach Engineers Inc

Printed 4/19/2024

HydroCAD® 10.20-3c s/n 00762 © 2023 HydroCAD Software Solutions LLC

Page 31

Summary for Subcatchment 8S: Subcatchment 8S

Runoff = 0.57 cfs @ 12.09 hrs, Volume= 0.048 af, Depth> 8.28"
 Routed to Pond CB103 : Catch Basin 103

Runoff by SCS TR-20 method, UH=SCS, Weighted-CN, Time Span= 0.00-24.00 hrs, dt= 0.05 hrs
 Type III 24-hr 50 Yr 24 Hr +15% Rainfall=8.53"

Area (sf)	CN	Description
2,554	98	Paved parking, HSG B
457	98	Roofs, HSG B
3,011	98	Weighted Average
3,011		100.00% Impervious Area

Tc (min)	Length (feet)	Slope (ft/ft)	Velocity (ft/sec)	Capacity (cfs)	Description
6.0					Direct Entry,

Summary for Subcatchment 9S: Subcatchment 9S

Runoff = 0.06 cfs @ 12.09 hrs, Volume= 0.005 af, Depth> 8.28"
 Routed to Pond CB104 : Catch Basin 104

Runoff by SCS TR-20 method, UH=SCS, Weighted-CN, Time Span= 0.00-24.00 hrs, dt= 0.05 hrs
 Type III 24-hr 50 Yr 24 Hr +15% Rainfall=8.53"

Area (sf)	CN	Description
325	98	Paved parking, HSG B
325		100.00% Impervious Area

Tc (min)	Length (feet)	Slope (ft/ft)	Velocity (ft/sec)	Capacity (cfs)	Description
6.0					Direct Entry,

Summary for Subcatchment 10S: Subcatchment 10S

Runoff = 0.49 cfs @ 12.10 hrs, Volume= 0.036 af, Depth> 5.16"
 Routed to Pond YD1 : Yard Drain 1

Runoff by SCS TR-20 method, UH=SCS, Weighted-CN, Time Span= 0.00-24.00 hrs, dt= 0.05 hrs
 Type III 24-hr 50 Yr 24 Hr +15% Rainfall=8.53"

Area (sf)	CN	Description
796	98	Roofs, HSG B
2,573	61	>75% Grass cover, Good, HSG B
261	98	Paved parking, HSG B
3,630	72	Weighted Average
2,573		70.88% Pervious Area
1,057		29.12% Impervious Area

18134-PROPOSED

Type III 24-hr 50 Yr 24 Hr +15% Rainfall=8.53"

Prepared by Jones & Beach Engineers Inc

Printed 4/19/2024

HydroCAD® 10.20-3c s/n 00762 © 2023 HydroCAD Software Solutions LLC

Page 32

Tc (min)	Length (feet)	Slope (ft/ft)	Velocity (ft/sec)	Capacity (cfs)	Description
2.2	42	0.1190	0.31		Sheet Flow, Grass: Short n= 0.150 P2= 3.70"
3.7	58	0.0650	0.26		Sheet Flow, Grass: Short n= 0.150 P2= 3.70"
0.4	42	0.0650	1.78		Shallow Concentrated Flow, Short Grass Pasture Kv= 7.0 fps
6.3	142	Total			

Summary for Subcatchment 11S: Subcatchment 11S

Runoff = 0.71 cfs @ 12.09 hrs, Volume= 0.052 af, Depth> 6.00"
Routed to Pond YD2 : Yard Drain 2

Runoff by SCS TR-20 method, UH=SCS, Weighted-CN, Time Span= 0.00-24.00 hrs, dt= 0.05 hrs
Type III 24-hr 50 Yr 24 Hr +15% Rainfall=8.53"

Area (sf)	CN	Description
1,998	98	Roofs, HSG B
2,312	61	>75% Grass cover, Good, HSG B
261	98	Paved parking, HSG B
4,571	79	Weighted Average
2,312		50.58% Pervious Area
2,259		49.42% Impervious Area

Tc (min)	Length (feet)	Slope (ft/ft)	Velocity (ft/sec)	Capacity (cfs)	Description
5.6	77	0.0396	0.23		Sheet Flow, Grass: Short n= 0.150 P2= 3.70"
5.6	77	Total, Increased to minimum Tc = 6.0 min			

Summary for Subcatchment 12S: Subcatchment 12S

Runoff = 0.53 cfs @ 12.09 hrs, Volume= 0.039 af, Depth> 5.40"
Routed to Pond YD3 : Yard Drain 3

Runoff by SCS TR-20 method, UH=SCS, Weighted-CN, Time Span= 0.00-24.00 hrs, dt= 0.05 hrs
Type III 24-hr 50 Yr 24 Hr +15% Rainfall=8.53"

Area (sf)	CN	Description
1,318	98	Roofs, HSG B
2,416	61	>75% Grass cover, Good, HSG B
3,734	74	Weighted Average
2,416		64.70% Pervious Area
1,318		35.30% Impervious Area

18134-PROPOSED

Type III 24-hr 50 Yr 24 Hr +15% Rainfall=8.53"

Prepared by Jones & Beach Engineers Inc

Printed 4/19/2024

HydroCAD® 10.20-3c s/n 00762 © 2023 HydroCAD Software Solutions LLC

Page 33

Tc (min)	Length (feet)	Slope (ft/ft)	Velocity (ft/sec)	Capacity (cfs)	Description
4.4	51	0.0320	0.19		Sheet Flow, Grass: Short n= 0.150 P2= 3.70"
4.4	51	Total, Increased to minimum Tc = 6.0 min			

Summary for Subcatchment 13S: Subcatchment 13S

Runoff = 0.16 cfs @ 12.09 hrs, Volume= 0.014 af, Depth> 8.28"
Routed to Pond 2P : Stone Drip Edge

Runoff by SCS TR-20 method, UH=SCS, Weighted-CN, Time Span= 0.00-24.00 hrs, dt= 0.05 hrs
Type III 24-hr 50 Yr 24 Hr +15% Rainfall=8.53"

Area (sf)	CN	Description
696	98	Roofs, HSG B
180	98	Water Surface, HSG B
876	98	Weighted Average
876		100.00% Impervious Area

Tc (min)	Length (feet)	Slope (ft/ft)	Velocity (ft/sec)	Capacity (cfs)	Description
6.0					Direct Entry,

Summary for Subcatchment 14S: Subcatchment 14S

Runoff = 0.11 cfs @ 12.09 hrs, Volume= 0.009 af, Depth> 8.28"
Routed to Pond 3P : Stone Under Deck

Runoff by SCS TR-20 method, UH=SCS, Weighted-CN, Time Span= 0.00-24.00 hrs, dt= 0.05 hrs
Type III 24-hr 50 Yr 24 Hr +15% Rainfall=8.53"

Area (sf)	CN	Description
560	98	Roofs, HSG B
560		100.00% Impervious Area

Tc (min)	Length (feet)	Slope (ft/ft)	Velocity (ft/sec)	Capacity (cfs)	Description
6.0					Direct Entry,

Summary for Subcatchment 15S: Subcatchment 15S

Runoff = 0.16 cfs @ 12.09 hrs, Volume= 0.014 af, Depth> 8.28"
Routed to Pond 4P : Stone Drip Edge

Runoff by SCS TR-20 method, UH=SCS, Weighted-CN, Time Span= 0.00-24.00 hrs, dt= 0.05 hrs
Type III 24-hr 50 Yr 24 Hr +15% Rainfall=8.53"

18134-PROPOSED

Type III 24-hr 50 Yr 24 Hr +15% Rainfall=8.53"

Prepared by Jones & Beach Engineers Inc

Printed 4/19/2024

HydroCAD® 10.20-3c s/n 00762 © 2023 HydroCAD Software Solutions LLC

Page 34

Area (sf)	CN	Description
696	98	Roofs, HSG B
180	98	Water Surface, HSG B
876	98	Weighted Average
876		100.00% Impervious Area

Tc (min)	Length (feet)	Slope (ft/ft)	Velocity (ft/sec)	Capacity (cfs)	Description
6.0					Direct Entry,

Summary for Subcatchment 18S: Subcatchment 18S

Runoff = 1.11 cfs @ 12.09 hrs, Volume= 0.081 af, Depth> 4.44"
 Routed to Pond 1P : Bioretention Pond

Runoff by SCS TR-20 method, UH=SCS, Weighted-CN, Time Span= 0.00-24.00 hrs, dt= 0.05 hrs
 Type III 24-hr 50 Yr 24 Hr +15% Rainfall=8.53"

Area (sf)	CN	Description
8,136	61	>75% Grass cover, Good, HSG B
938	98	Roofs, HSG B
400	98	Paved parking, HSG B
9,474	66	Weighted Average
8,136		85.88% Pervious Area
1,338		14.12% Impervious Area

Tc (min)	Length (feet)	Slope (ft/ft)	Velocity (ft/sec)	Capacity (cfs)	Description
2.5	43	0.0930	0.29		Sheet Flow, Grass: Short n= 0.150 P2= 3.70"
0.6	15	0.3333	0.39		Sheet Flow, Grass: Short n= 0.150 P2= 3.70"
3.1	58	Total, Increased to minimum Tc = 6.0 min			

Summary for Reach 1R: Ditch on Tidewatch Property

[62] Hint: Exceeded Reach 2R OUTLET depth by 0.49' @ 12.35 hrs

[62] Hint: Exceeded Reach 4R OUTLET depth by 0.45' @ 12.20 hrs

Inflow Area = 1.685 ac, 18.36% Impervious, Inflow Depth > 3.28" for 50 Yr 24 Hr +15% event

Inflow = 3.98 cfs @ 12.34 hrs, Volume= 0.460 af

Outflow = 3.98 cfs @ 12.35 hrs, Volume= 0.460 af, Atten= 0%, Lag= 0.7 min

Routed to Reach AP3 : Analysis Point 3

Routing by Dyn-Stor-Ind method, Time Span= 0.00-24.00 hrs, dt= 0.05 hrs / 3

Max. Velocity= 3.08 fps, Min. Travel Time= 0.9 min

Avg. Velocity= 1.30 fps, Avg. Travel Time= 2.0 min

18134-PROPOSED

Type III 24-hr 50 Yr 24 Hr +15% Rainfall=8.53"

Prepared by Jones & Beach Engineers Inc

Printed 4/19/2024

HydroCAD® 10.20-3c s/n 00762 © 2023 HydroCAD Software Solutions LLC

Page 35

Peak Storage= 205 cf @ 12.35 hrs
Average Depth at Peak Storage= 0.51' , Surface Width= 4.06'
Bank-Full Depth= 1.00' Flow Area= 4.0 sf, Capacity= 18.18 cfs

1.00' x 1.00' deep channel, n= 0.030 Stream, clean & straight
Side Slope Z-value= 3.0 '/' Top Width= 7.00'
Length= 159.0' Slope= 0.0189 '/'
Inlet Invert= 38.00', Outlet Invert= 35.00'

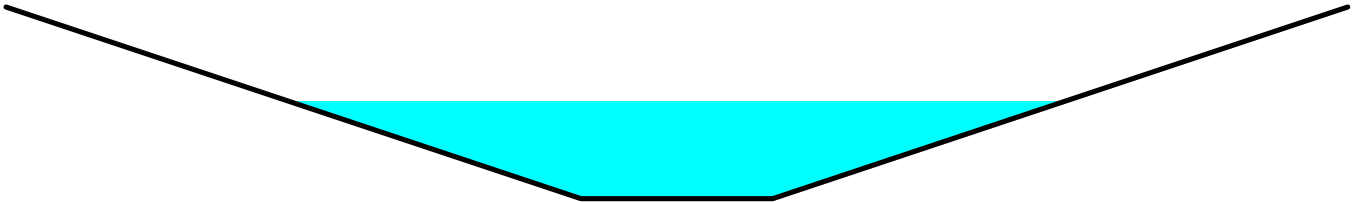

Summary for Reach 2R: Flow through 3S

Inflow	=	0.12 cfs @ 12.26 hrs,	Volume=	0.006 af
Outflow	=	0.12 cfs @ 12.20 hrs,	Volume=	0.006 af, Atten= 0%, Lag= 0.0 min
Routed to Reach 1R : Ditch on Tidewatch Property				

Routing by Dyn-Stor-Ind method, Time Span= 0.00-24.00 hrs, dt= 0.05 hrs / 3
Max. Velocity= 1.55 fps, Min. Travel Time= 0.9 min
Avg. Velocity = 1.07 fps, Avg. Travel Time= 1.3 min

Peak Storage= 6 cf @ 12.20 hrs
Average Depth at Peak Storage= 0.02' , Surface Width= 6.47'
Bank-Full Depth= 1.00' Flow Area= 33.3 sf, Capacity= 740.30 cfs

50.00' x 1.00' deep Parabolic Channel, n= 0.030 Stream, clean & straight
Length= 81.0' Slope= 0.3457 '/'
Inlet Invert= 66.00', Outlet Invert= 38.00'



‡

Summary for Reach 4R: Flow Through 3S

Inflow Area =	0.648 ac, 45.28% Impervious, Inflow Depth > 2.27"	for 50 Yr 24 Hr +15% event
Inflow	=	1.18 cfs @ 12.42 hrs, Volume= 0.122 af
Outflow	=	1.17 cfs @ 12.43 hrs, Volume= 0.122 af, Atten= 1%, Lag= 0.8 min
Routed to Reach 1R : Ditch on Tidewatch Property		

18134-PROPOSED

Type III 24-hr 50 Yr 24 Hr +15% Rainfall=8.53"

Prepared by Jones & Beach Engineers Inc

Printed 4/19/2024

HydroCAD® 10.20-3c s/n 00762 © 2023 HydroCAD Software Solutions LLC

Page 36

Routing by Dyn-Stor-Ind method, Time Span= 0.00-24.00 hrs, dt= 0.05 hrs / 3
Max. Velocity= 3.19 fps, Min. Travel Time= 1.1 min
Avg. Velocity = 1.09 fps, Avg. Travel Time= 3.4 min

Peak Storage= 81 cf @ 12.43 hrs
Average Depth at Peak Storage= 0.11' , Surface Width= 3.66'
Bank-Full Depth= 1.00' Flow Area= 6.0 sf, Capacity= 66.79 cfs

3.00' x 1.00' deep channel, n= 0.030 Stream, clean & straight
Side Slope Z-value= 3.0 '/' Top Width= 9.00'
Length= 220.0' Slope= 0.0909 '/'
Inlet Invert= 58.00', Outlet Invert= 38.00'



Summary for Reach AP1: Analysis Point 1

[40] Hint: Not Described (Outflow=Inflow)

Inflow Area =	0.170 ac, 50.61% Impervious, Inflow Depth > 6.12"	for 50 Yr 24 Hr +15% event
Inflow =	1.17 cfs @ 12.09 hrs, Volume=	0.087 af
Outflow =	1.17 cfs @ 12.09 hrs, Volume=	0.087 af, Atten= 0%, Lag= 0.0 min

Routing by Dyn-Stor-Ind method, Time Span= 0.00-24.00 hrs, dt= 0.05 hrs / 3

Summary for Reach AP2: Analysis Point 2

[40] Hint: Not Described (Outflow=Inflow)

Inflow Area =	0.040 ac, 0.00% Impervious, Inflow Depth > 3.85"	for 50 Yr 24 Hr +15% event
Inflow =	0.17 cfs @ 12.10 hrs, Volume=	0.013 af
Outflow =	0.17 cfs @ 12.10 hrs, Volume=	0.013 af, Atten= 0%, Lag= 0.0 min

Routing by Dyn-Stor-Ind method, Time Span= 0.00-24.00 hrs, dt= 0.05 hrs / 3

Summary for Reach AP3: Analysis Point 3

[40] Hint: Not Described (Outflow=Inflow)

Inflow Area =	2.167 ac, 16.06% Impervious, Inflow Depth > 3.48"	for 50 Yr 24 Hr +15% event
Inflow =	5.03 cfs @ 12.33 hrs, Volume=	0.629 af
Outflow =	5.03 cfs @ 12.33 hrs, Volume=	0.629 af, Atten= 0%, Lag= 0.0 min

18134-PROPOSED

Type III 24-hr 50 Yr 24 Hr +15% Rainfall=8.53"

Prepared by Jones & Beach Engineers Inc

Printed 4/19/2024

HydroCAD® 10.20-3c s/n 00762 © 2023 HydroCAD Software Solutions LLC

Page 37

Routing by Dyn-Stor-Ind method, Time Span= 0.00-24.00 hrs, dt= 0.05 hrs / 3

Summary for Pond 1P: Bioretention Pond

Existing high contour within footprint of filter course = 61.0, SHWT depth = 35" per TP 10, so SHWT El. = 58.08, which is 0.01' below the bottom of stone. However, in our experience, modelling the SHWT with such a small separation to the bottom of stone causes an unrealistically high amount of infiltration to appear in the calculations. Therefore, the SHWT has been modelled 2" lower as a factor of safety.

Inflow Area = 0.648 ac, 45.28% Impervious, Inflow Depth > 5.84" for 50 Yr 24 Hr +15% event
 Inflow = 4.12 cfs @ 12.09 hrs, Volume= 0.315 af
 Outflow = 1.30 cfs @ 12.42 hrs, Volume= 0.254 af, Atten= 68%, Lag= 19.6 min
 Discarded = 0.12 cfs @ 12.42 hrs, Volume= 0.132 af
 Primary = 1.18 cfs @ 12.42 hrs, Volume= 0.122 af
 Routed to Reach 4R : Flow Through 3S

Routing by Dyn-Stor-Ind method, Time Span= 0.00-24.00 hrs, dt= 0.05 hrs / 3
 Peak Elev= 62.85' @ 12.42 hrs Surf.Area= 3,187 sf Storage= 5,639 cf

Plug-Flow detention time= 216.2 min calculated for 0.254 af (81% of inflow)
 Center-of-Mass det. time= 139.8 min (930.8 - 791.0)

Volume	Invert	Avail.Storage	Storage Description			
#1	58.09'	6,166 cf	Custom Stage Data (Irregular) Listed below (Recalc)			
Elevation (feet)	Surf.Area (sq-ft)	Perim. (feet)	Voids (%)	Inc.Store (cubic-feet)	Cum.Store (cubic-feet)	Wet.Area (sq-ft)
58.09	466	106.0	0.0	0	0	466
58.10	466	106.0	40.0	2	2	467
59.09	466	106.0	40.0	185	186	572
59.10	466	106.0	15.0	1	187	573
60.59	466	106.0	15.0	104	291	731
60.60	466	106.0	100.0	5	296	732
61.00	2,114	176.0	100.0	476	772	2,304
62.00	2,672	195.0	100.0	2,388	3,160	2,895
63.00	3,285	215.0	100.0	2,973	6,133	3,579
63.01	3,285	215.0	100.0	33	6,166	3,581

Device	Routing	Invert	Outlet Devices
#1	Primary	58.60'	12.0" Round Culvert L= 18.0' CPP, projecting, no headwall, Ke= 0.900 Inlet / Outlet Invert= 58.60' / 58.00' S= 0.0333 '/ Cc= 0.900 n= 0.012, Flow Area= 0.79 sf
#2	Device 1	58.90'	1.0" Vert. Orifice/Grate C= 0.600 Limited to weir flow at low heads
#3	Device 1	62.65'	15.0" Horiz. Orifice/Grate C= 0.600 Limited to weir flow at low heads
#4	Discarded	58.09'	0.300 in/hr Exfiltration over Surface area Conductivity to Groundwater Elevation = 57.92' Phase-In= 0.10'

18134-PROPOSED

Type III 24-hr 50 Yr 24 Hr +15% Rainfall=8.53"

Prepared by Jones & Beach Engineers Inc

Printed 4/19/2024

HydroCAD® 10.20-3c s/n 00762 © 2023 HydroCAD Software Solutions LLC

Page 38

Discarded OutFlow Max=0.12 cfs @ 12.42 hrs HW=62.85' (Free Discharge)

↑4=Exfiltration (Controls 0.12 cfs)

Primary OutFlow Max=1.16 cfs @ 12.42 hrs HW=62.85' TW=58.11' (Dynamic Tailwater)

↑1=Culvert (Passes 1.16 cfs of 5.78 cfs potential flow)

↑2=Orifice/Grate (Orifice Controls 0.05 cfs @ 9.51 fps)

↑3=Orifice/Grate (Weir Controls 1.11 cfs @ 1.45 fps)

Summary for Pond 2P: Stone Drip Edge

Ledge surface modelled 15" below original grade based on TP 1 and TP 4. Proposed grade is approximately 4' above existing grade and therefore 5.25' above ledge.

Inflow Area =	0.020 ac, 100.00% Impervious, Inflow Depth > 8.28"	for 50 Yr 24 Hr +15% event
Inflow =	0.16 cfs @ 12.09 hrs, Volume=	0.014 af
Outflow =	0.11 cfs @ 12.20 hrs, Volume=	0.009 af, Atten= 32%, Lag= 6.6 min
Discarded =	0.00 cfs @ 12.15 hrs, Volume=	0.005 af
Secondary =	0.11 cfs @ 12.20 hrs, Volume=	0.004 af
Routed to Reach 2R : Flow through 3S		

Routing by Dyn-Stor-Ind method, Time Span= 0.00-24.00 hrs, dt= 0.05 hrs / 3
Peak Elev= 66.01' @ 12.15 hrs Surf.Area= 0.004 ac Storage= 0.006 af

Plug-Flow detention time= 220.2 min calculated for 0.009 af (64% of inflow)
Center-of-Mass det. time= 113.7 min (853.7 - 740.0)

Volume	Invert	Avail.Storage	Storage Description
#1	62.50'	0.006 af	3.00'W x 60.00'L x 3.51'H Prismaoid 0.015 af Overall x 40.0% Voids

Device	Routing	Invert	Outlet Devices
#0	Secondary	66.01'	Automatic Storage Overflow (Discharged without head)
#1	Discarded	62.50'	0.300 in/hr Exfiltration over Surface area Conductivity to Groundwater Elevation = 60.75' Phase-In= 0.10'

Discarded OutFlow Max=0.00 cfs @ 12.15 hrs HW=66.01' (Free Discharge)

↑1=Exfiltration (Controls 0.00 cfs)

Secondary OutFlow Max=0.00 cfs @ 12.20 hrs HW=66.01' TW=66.02' (Dynamic Tailwater)

Summary for Pond 3P: Stone Under Deck

Ledge surface modelled 15" below original grade based on TP 1 and TP 4. Proposed grade is approximately 3.2' above existing grade and therefore 4.45' above ledge.

18134-PROPOSED

Type III 24-hr 50 Yr 24 Hr +15% Rainfall=8.53"

Prepared by Jones & Beach Engineers Inc

Printed 4/19/2024

HydroCAD® 10.20-3c s/n 00762 © 2023 HydroCAD Software Solutions LLC

Page 39

Inflow Area = 0.013 ac, 100.00% Impervious, Inflow Depth > 8.28" for 50 Yr 24 Hr +15% event
 Inflow = 0.11 cfs @ 12.09 hrs, Volume= 0.009 af
 Outflow = 0.05 cfs @ 12.30 hrs, Volume= 0.006 af, Atten= 56%, Lag= 13.1 min
 Discarded = 0.00 cfs @ 12.25 hrs, Volume= 0.004 af
 Secondary = 0.04 cfs @ 12.30 hrs, Volume= 0.002 af
 Routed to Reach 2R : Flow through 3S

Routing by Dyn-Stor-Ind method, Time Span= 0.00-24.00 hrs, dt= 0.05 hrs / 3
 Peak Elev= 66.20' @ 12.25 hrs Surf.Area= 0.006 ac Storage= 0.004 af

Plug-Flow detention time= 224.3 min calculated for 0.006 af (66% of inflow)
 Center-of-Mass det. time= 122.1 min (862.1 - 740.0)

Volume	Invert	Avail.Storage	Storage Description
#1	64.70'	0.004 af	14.00'W x 20.00'L x 1.50'H Prismaoid 0.010 af Overall x 40.0% Voids

Device	Routing	Invert	Outlet Devices
#0	Secondary	66.20'	Automatic Storage Overflow (Discharged without head)
#1	Discarded	64.70'	0.300 in/hr Exfiltration over Surface area Conductivity to Groundwater Elevation = 61.75' Phase-In= 0.10'

Discarded OutFlow Max=0.00 cfs @ 12.25 hrs HW=66.20' (Free Discharge)
 ↑**1=Exfiltration** (Controls 0.00 cfs)

Secondary OutFlow Max=0.00 cfs @ 12.30 hrs HW=66.20' TW=66.02' (Dynamic Tailwater)

Summary for Pond 4P: Stone Drip Edge

Ledge surface modelled 15" below original grade based on TP 1 and TP 4. Proposed grade is approximately 4' above existing grade and therefore 5.25' above ledge.

Inflow Area = 0.020 ac, 100.00% Impervious, Inflow Depth > 8.28" for 50 Yr 24 Hr +15% event
 Inflow = 0.16 cfs @ 12.09 hrs, Volume= 0.014 af
 Outflow = 0.03 cfs @ 12.55 hrs, Volume= 0.010 af, Atten= 81%, Lag= 27.8 min
 Discarded = 0.01 cfs @ 12.50 hrs, Volume= 0.009 af
 Secondary = 0.02 cfs @ 12.55 hrs, Volume= 0.001 af
 Routed to Reach 2R : Flow through 3S

Routing by Dyn-Stor-Ind method, Time Span= 0.00-24.00 hrs, dt= 0.05 hrs / 3
 Peak Elev= 66.01' @ 12.50 hrs Surf.Area= 0.004 ac Storage= 0.007 af

Plug-Flow detention time= 297.2 min calculated for 0.010 af (70% of inflow)
 Center-of-Mass det. time= 201.2 min (941.2 - 740.0)

Volume	Invert	Avail.Storage	Storage Description
#1	61.50'	0.007 af	3.00'W x 60.00'L x 4.51'H Prismaoid 0.019 af Overall x 40.0% Voids

18134-PROPOSED

Type III 24-hr 50 Yr 24 Hr +15% Rainfall=8.53"

Prepared by Jones & Beach Engineers Inc

Printed 4/19/2024

HydroCAD® 10.20-3c s/n 00762 © 2023 HydroCAD Software Solutions LLC

Page 40

Device	Routing	Invert	Outlet Devices
#0	Secondary	66.01'	Automatic Storage Overflow (Discharged without head)
#1	Discarded	61.50'	0.300 in/hr Exfiltration over Surface area Conductivity to Groundwater Elevation = 60.75' Phase-In= 0.10'

Discarded OutFlow Max=0.01 cfs @ 12.50 hrs HW=66.01' (Free Discharge)

↑1=Exfiltration (Controls 0.01 cfs)

Secondary OutFlow Max=0.00 cfs @ 12.55 hrs HW=66.01' TW=66.01' (Dynamic Tailwater)**Summary for Pond CB101: Catch Basin 101**

Inflow Area = 0.128 ac, 53.91% Impervious, Inflow Depth > 6.25" for 50 Yr 24 Hr +15% event
 Inflow = 0.86 cfs @ 12.09 hrs, Volume= 0.067 af
 Outflow = 0.86 cfs @ 12.09 hrs, Volume= 0.067 af, Atten= 0%, Lag= 0.0 min
 Primary = 0.86 cfs @ 12.09 hrs, Volume= 0.067 af
 Routed to Pond CB102 : Catch Basin 102

Routing by Dyn-Stor-Ind method, Time Span= 0.00-24.00 hrs, dt= 0.05 hrs / 3

Peak Elev= 63.28' @ 12.10 hrs

Flood Elev= 65.60'

Device	Routing	Invert	Outlet Devices
#1	Primary	62.30'	12.0" Round Culvert L= 19.0' CPP, projecting, no headwall, Ke= 0.900 Inlet / Outlet Invert= 62.30' / 62.20' S= 0.0053 '/' Cc= 0.900 n= 0.012, Flow Area= 0.79 sf

Primary OutFlow Max=0.00 cfs @ 12.09 hrs HW=63.24' TW=63.35' (Dynamic Tailwater)

↑1=Culvert (Controls 0.00 cfs)

Summary for Pond CB102: Catch Basin 102

[80] Warning: Exceeded Pond CB101 by 0.14' @ 12.10 hrs (1.10 cfs 0.017 af)

Inflow Area = 0.163 ac, 63.75% Impervious, Inflow Depth > 6.69" for 50 Yr 24 Hr +15% event
 Inflow = 1.14 cfs @ 12.09 hrs, Volume= 0.091 af
 Outflow = 1.14 cfs @ 12.09 hrs, Volume= 0.091 af, Atten= 0%, Lag= 0.0 min
 Primary = 1.14 cfs @ 12.09 hrs, Volume= 0.091 af
 Routed to Pond CB104 : Catch Basin 104

Routing by Dyn-Stor-Ind method, Time Span= 0.00-24.00 hrs, dt= 0.05 hrs / 3

Peak Elev= 63.42' @ 12.11 hrs

Flood Elev= 65.60'

Device	Routing	Invert	Outlet Devices
#1	Primary	62.10'	12.0" Round Culvert L= 147.0' CPP, projecting, no headwall, Ke= 0.900 Inlet / Outlet Invert= 62.10' / 61.30' S= 0.0054 '/' Cc= 0.900 n= 0.012, Flow Area= 0.79 sf

18134-PROPOSED

Type III 24-hr 50 Yr 24 Hr +15% Rainfall=8.53"

Prepared by Jones & Beach Engineers Inc

Printed 4/19/2024

HydroCAD® 10.20-3c s/n 00762 © 2023 HydroCAD Software Solutions LLC

Page 41

Primary OutFlow Max=1.17 cfs @ 12.09 hrs HW=63.34' TW=63.16' (Dynamic Tailwater)

↑1=Culvert (Outlet Controls 1.17 cfs @ 1.54 fps)

Summary for Pond CB103: Catch Basin 103

Inflow Area = 0.260 ac, 58.22% Impervious, Inflow Depth > 6.41" for 50 Yr 24 Hr +15% event

Inflow = 1.81 cfs @ 12.09 hrs, Volume= 0.139 af

Outflow = 1.81 cfs @ 12.09 hrs, Volume= 0.139 af, Atten= 0%, Lag= 0.0 min

Primary = 1.81 cfs @ 12.09 hrs, Volume= 0.139 af

Routed to Pond CB104 : Catch Basin 104

Routing by Dyn-Stor-Ind method, Time Span= 0.00-24.00 hrs, dt= 0.05 hrs / 3

Peak Elev= 67.16' @ 12.09 hrs

Flood Elev= 73.00'

Device	Routing	Invert	Outlet Devices
#1	Primary	66.30'	12.0" Round Culvert L= 43.0' CPP, projecting, no headwall, Ke= 0.900 Inlet / Outlet Invert= 66.30' / 66.00' S= 0.0070 '/ Cc= 0.900 n= 0.012, Flow Area= 0.79 sf

Primary OutFlow Max=1.76 cfs @ 12.09 hrs HW=67.15' TW=63.15' (Dynamic Tailwater)

↑1=Culvert (Inlet Controls 1.76 cfs @ 2.48 fps)

Summary for Pond CB104: Catch Basin 104

Inflow Area = 0.430 ac, 61.04% Impervious, Inflow Depth > 6.55" for 50 Yr 24 Hr +15% event

Inflow = 3.01 cfs @ 12.09 hrs, Volume= 0.235 af

Outflow = 3.01 cfs @ 12.09 hrs, Volume= 0.235 af, Atten= 0%, Lag= 0.0 min

Primary = 3.01 cfs @ 12.09 hrs, Volume= 0.235 af

Routed to Pond 1P : Bioretention Pond

Routing by Dyn-Stor-Ind method, Time Span= 0.00-24.00 hrs, dt= 0.05 hrs / 3

Peak Elev= 63.25' @ 12.11 hrs

Flood Elev= 70.80'

Device	Routing	Invert	Outlet Devices
#1	Primary	61.20'	12.0" Round Culvert L= 45.0' CPP, projecting, no headwall, Ke= 0.900 Inlet / Outlet Invert= 61.20' / 60.90' S= 0.0067 '/ Cc= 0.900 n= 0.012, Flow Area= 0.79 sf

Primary OutFlow Max=2.94 cfs @ 12.09 hrs HW=63.15' TW=62.18' (Dynamic Tailwater)

↑1=Culvert (Inlet Controls 2.94 cfs @ 3.74 fps)

Summary for Pond YD1: Yard Drain 1

Inflow Area = 0.083 ac, 29.12% Impervious, Inflow Depth > 5.16" for 50 Yr 24 Hr +15% event
Inflow = 0.49 cfs @ 12.10 hrs, Volume= 0.036 af
Outflow = 0.49 cfs @ 12.10 hrs, Volume= 0.036 af, Atten= 0%, Lag= 0.0 min
Primary = 0.49 cfs @ 12.10 hrs, Volume= 0.036 af
Routed to Pond CB101 : Catch Basin 101

Routing by Dyn-Stor-Ind method, Time Span= 0.00-24.00 hrs, dt= 0.05 hrs / 3
Peak Elev= 63.50' @ 12.15 hrs
Flood Elev= 65.80'

Table with 4 columns: Device, Routing, Invert, Outlet Devices. Row 1: #1, Primary, 62.80', 8.0" Round Culvert, L= 9.0' CPP, projecting, no headwall, Ke= 0.900, Inlet / Outlet Invert= 62.80' / 62.63', S= 0.0189 '/ Cc= 0.900, n= 0.012, Flow Area= 0.35 sf

Primary OutFlow Max=0.34 cfs @ 12.10 hrs HW=63.34' TW=63.25' (Dynamic Tailwater)
1=Culvert (Inlet Controls 0.34 cfs @ 1.12 fps)

Summary for Pond YD2: Yard Drain 2

Inflow Area = 0.105 ac, 49.42% Impervious, Inflow Depth > 6.00" for 50 Yr 24 Hr +15% event
Inflow = 0.71 cfs @ 12.09 hrs, Volume= 0.052 af
Outflow = 0.71 cfs @ 12.09 hrs, Volume= 0.052 af, Atten= 0%, Lag= 0.0 min
Primary = 0.71 cfs @ 12.09 hrs, Volume= 0.052 af
Routed to Pond CB103 : Catch Basin 103

Routing by Dyn-Stor-Ind method, Time Span= 0.00-24.00 hrs, dt= 0.05 hrs / 3
Peak Elev= 67.72' @ 12.09 hrs
Flood Elev= 69.30'

Table with 4 columns: Device, Routing, Invert, Outlet Devices. Row 1: #1, Primary, 67.10', 8.0" Round Culvert, L= 52.0' CPP, projecting, no headwall, Ke= 0.900, Inlet / Outlet Invert= 67.10' / 66.80', S= 0.0058 '/ Cc= 0.900, n= 0.012, Flow Area= 0.35 sf

Primary OutFlow Max=0.70 cfs @ 12.09 hrs HW=67.71' TW=67.15' (Dynamic Tailwater)
1=Culvert (Inlet Controls 0.70 cfs @ 2.09 fps)

Summary for Pond YD3: Yard Drain 3

Inflow Area = 0.086 ac, 35.30% Impervious, Inflow Depth > 5.40" for 50 Yr 24 Hr +15% event
Inflow = 0.53 cfs @ 12.09 hrs, Volume= 0.039 af
Outflow = 0.53 cfs @ 12.09 hrs, Volume= 0.039 af, Atten= 0%, Lag= 0.0 min
Primary = 0.53 cfs @ 12.09 hrs, Volume= 0.039 af
Routed to Pond CB103 : Catch Basin 103

Routing by Dyn-Stor-Ind method, Time Span= 0.00-24.00 hrs, dt= 0.05 hrs / 3

18134-PROPOSED

Type III 24-hr 50 Yr 24 Hr +15% Rainfall=8.53"

Prepared by Jones & Beach Engineers Inc

Printed 4/19/2024

HydroCAD® 10.20-3c s/n 00762 © 2023 HydroCAD Software Solutions LLC

Page 43

Peak Elev= 68.50' @ 12.09 hrs

Flood Elev= 70.20'

Device	Routing	Invert	Outlet Devices
#1	Primary	68.00'	8.0" Round Culvert L= 13.0' CPP, projecting, no headwall, Ke= 0.900 Inlet / Outlet Invert= 68.00' / 66.80' S= 0.0923 '/ Cc= 0.900 n= 0.012, Flow Area= 0.35 sf

Primary OutFlow Max=0.52 cfs @ 12.09 hrs HW=68.49' TW=67.15' (Dynamic Tailwater)

↑**1=Culvert** (Inlet Controls 0.52 cfs @ 1.88 fps)

APPENDIX III

Test Pit Logs

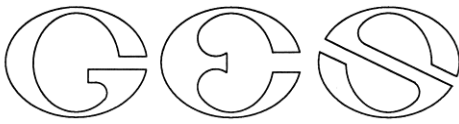

GOVE ENVIRONMENTAL SERVICES, INC.

TEST PIT DATA

Project 635 Sagamore Ave
Client 635 Sagamore Development LLC
GES Project No. GES 2021307
MM/DD/YY Staff 3-18-2022 JPG

Test Pit No. 1

ESHWT: n/a

Termination @ 15"

Refusal: 15"

SCS Soil:

Hollis

Obs. Water: none

Depth	Color	Texture	Structure	Consistence	Redox; Quantity/Contrast
0-5"	10YR 3/2	FSL	GR	FR	NONE
5-15"	10YR 5/6	FSL	GR	FR	NONE

Test Pit No. 2

ESHWT: n/a

Termination @ 25"

Refusal: 25"

SCS Soil:

Chatfield

Obs. Water: none

Depth	Color	Texture	Structure	Consistence	Redox; Quantity/Contrast
0-5"	10YR 3/2	FSL	GR	FR	NONE
5-25"	10YR 5/6	FSL	GR	FR	NONE

Test Pit No. 3

ESHWT: n/a

Termination @ 25"

Refusal: 25"

SCS Soil:

Chatfield

Obs. Water: none

Depth	Color	Texture	Structure	Consistence	Redox; Quantity/Contrast
0-6"	10YR 3/2	FSL	GR	FR	NONE
6-25"	10YR 5/6	FSL	GR	FR	NONE

8 Continental Dr Bldg 2 Unit H, Exeter, NH 03833-7526

Ph (603) 778 0644 / Fax (603) 778 0654

info@gesinc.biz

www.gesinc.biz

Test Pit No. 4

ESHWT: n/a
Termination @ 15"
Refusal: 15"
Obs. Water: none

SCS Soil: Hollis

Depth	Color	Texture	Structure	Consistence	Redox; Quantity/Contrast
0–15"	10YR 3/2	FSL	GR	FR	NONE

Test Pit No. 5

ESHWT: 30"
Termination @ 36"
Refusal: 36"
Obs. Water: none

SCS Soil: Chatfield variant

Depth	Color	Texture	Structure	Consistence	Redox; Quantity/Contrast
0–8"	10YR 3/2	FSL	GR	FR	NONE
8–30"	10YR 4/6	FSL	GR	FR	NONE
30–36"	2.5Y 5/3	FSL	GR	FR	10% Distinct

Test Pit No. 6

ESHWT: n/a
Termination @ 12"
Refusal: 12"
Obs. Water: none

SCS Soil: Hollis

Depth	Color	Texture	Structure	Consistence	Redox; Quantity/Contrast
0–12"	10YR 3/2	FSL	GR	FR	NONE

Test Pit No. 7

ESHWT: n/a
Termination @ 27"
Refusal: 27"
Obs. Water: none

SCS Soil: Chatfield

Depth	Color	Texture	Structure	Consistence	Redox; Quantity/Contrast
0–4"	10YR 3/2	FSL	GR	FR	NONE
4–27"	10YR 5/6	FSL	GR	FR	NONE

Test Pit No. 8

ESHWT: 35"
 Termination @ 40"
 Refusal: 40"
 Obs. Water: none

SCS Soil: Chatfield variant

Depth	Color	Texture	Structure	Consistence	Redox; Quantity/Contrast
0-6"	10YR 3/2	FSL	GR	FR	NONE
6-35"	10YR 5/6	FSL	GR	FR	NONE
35-40"	2.5Y 5/3	FSL	OM	FI	10% Distinct

Test Pit No. 9

ESHWT: n/a
 Termination @ 27"
 Refusal: 27"
 Obs. Water: none

SCS Soil: Chatfield

Depth	Color	Texture	Structure	Consistence	Redox; Quantity/Contrast
0-4"	10YR 3/2	FSL	GR	FR	NONE
4-27"	10YR 5/6	FSL	GR	FR	NONE

Test Pit No. 10

ESHWT: 35
 Termination @ 62"
 Refusal: 62"
 Obs. Water: none

SCS Soil: Scituate

Depth	Color	Texture	Structure	Consistence	Redox; Quantity/Contrast
0-10"	10YR 3/2	FSL	GR	FR	NONE
10-35"	10YR 5/6	FSL	GR	FR	NONE
35-62"	2.5Y 5/3	FSL	PL	FI	10%, Distinct

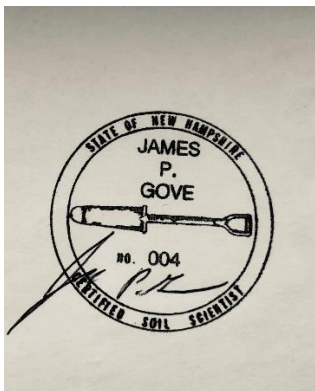

3-21-2022

Legend:

FSL = fine sandy loam

GR = granular

PL = platy

FI = firm

APPENDIX IV

Site Specific Soil Survey Report and Map



GOVE ENVIRONMENTAL SERVICES, INC

SITE-SPECIFIC SOIL SURVEY REPORT

For

635 Sagamore Avenue, Portsmouth, NH

By

GES, Inc.

Project # 2021308

Date: 02-20-2024

1. MAPPING STANDARDS

Site-Specific Soil Mapping Standards for New Hampshire and Vermont. SSSNNE Special Publication No. 3, Version 7.0, July, 2021.

This map product is within the technical standards of the National Cooperative Soil Survey. It is a special purpose product, intended for infiltration requirements by the NH DES Alteration of Terrain Bureau. The soil map was produced by a professional soil scientist and is not a product of the USDA Natural Resources Conservation Service. This report accompanies the soil map.

The site-specific soil map (SSSM) was produced 2-20-2024; prepared by JP Gove, CSS #004, GES, Inc.

Soils were identified with the New Hampshire State-wide Numerical Soils Legend, USDA NRCS, Durham, NH. Issue # 10, January 2011.

Hydrologic Soil Group was determined using SSSNNE Special Publication No. 5, Ksat Values for New Hampshire Soils, September 2009.

High Intensity Soil Map symbols, based upon SSSNNE Special Publication 1, December 2017, were added to the Soil Legend.

Scale of soil map: Approximately 1" = 20'.

Contours Interval: 2 feet

2. LANDFORMS & EXISTING CONDITIONS:

The site is located on sloping hillside that is bedrock controlled. Rock outcrops are numerous. At the top of the hill, adjacent Sagamore Avenue, is an existing commercial building and paved areas. Behind the impervious areas to the south, the hillside slopes downward. The area is forested in white pines. There are no wetlands on the site.

3. DATE SOIL MAP PRODUCED

Date(s) of on-site field work: 3-18-2022
Date(s) of test pits: 3-18-2922
Test pits recorded by: JP Gove, CSS # 004

4. GEOGRAPHIC LOCATION AND SIZE OF SITE

City or town where soil mapping was conducted: Portsmouth, NH
Location: Tax Map 222 Lot 19
Size of area: Approximately 2 acres
Was the map for the entire lot? Yes
If no, where was the mapping conducted on the parcel: n/a

5. PURPOSE OF THE SOIL MAP

Was the map prepared to meet the requirement of Alteration of Terrain? No
If no, what was the purpose of the map? City of Portsmouth requirements
Who was the map prepared for? Jones & Beach Engineers, Inc.



6. SOIL IDENTIFICATION LEGEND

Map Unit Symbol	Map Unit Name	HISS Symbol	Hydrologic Soil Group
41	Chatfield-Hollis-Rock Outcrop complex	228	B
289	Chatfield Variant (moderately well drained)	327	B
699	Urban Land	n/a	Impervious

SLOPE PHASE:

0-8%	B	8-15%	C	15-25%	D
25%-50%	E	50%+	F		

7. NARRATIVE MAP UNIT DESCRIPTIONS

SITE-SPECIFIC MAP UNIT: 41

CORRELATED SOIL SERIES: Chatfield-Hollis-Rock Outcrop complex

LANDSCAPE SETTING: Sloping to very steep hillside.

CHARACTERISTIC SURFACE FEATURES: Numerous rock outcrops

DRAINAGE CLASS: Well drained

PARENT MATERIAL: Glacial Till

NATURE OF DISSIMILAR INCLUSIONS: With a complex, several similar soils are present. While the major soil is the moderately deep Chatfield, the shallow Hollis and the exposed ledge of the Rock Outcrop, are large minor components. Chatfield is 50%, Hollis is 25%, and Rock Outcrop is 25%. A few deeper soil areas are present in hollow in the bedrock.

ESTIMATED PERCENTAGE OF DISSIMILAR INCLUSIONS: less than 5%.

SOIL PROFILE DESCRIPTIONS- horizon designation, depth, soil texture, Munsell color notation, Munsell color of redox features, soil structure, soil consistence, estimated coarse fragments, estimated seasonal high water table (ESHWT), observed water table (OBSWT), kind of water table (perched, apparent, or both), depth to lithic or paralithic contact:

Test Pit No. 3

ESHWT: n/a

Termination @ 25"

Refusal: 25"

SCS Soil:

Chatfield

Obs. Water: none

Depth	Color	Texture	Structure	Consistence	Redox; Quantity/Contrast
0-6"	10YR 3/2	FSL	GR	FR	NONE
6-25"	10YR 5/6	FSL	GR	FR	NONE

No OBSWT, no ESHWT, lithic contact at 25", 20% rock fragments.

Test Pit No. 1

ESHWT: n/a

Termination @ 15"

Refusal: 15"

SCS Soil:

Hollis

Obs. Water: none

Depth	Color	Texture	Structure	Consistence	Redox; Quantity/Contrast
0-5"	10YR 3/2	FSL	GR	FR	NONE
5-15"	10YR 5/6	FSL	GR	FR	NONE

No OBSWT, no ESHWT, lithic contact at 15", 20% rock fragments.

SITE-SPECIFIC MAP UNIT: 289

CORRELATED SOIL SERIES: Chatfield Variant (moderately well drained)



LANDSCAPE SETTING: At the top of the slope, a slightly deeper soil area on the northwest corner of the site.

CHARACTERISTIC SURFACE FEATURES: Fewer outcrops than the rest of the site.

DRAINAGE CLASS: Moderately well drained.

PARENT MATERIAL: Glacial till.

NATURE OF DISSIMILAR INCLUSIONS: Scituate soils with a hard pan above the bedrock,

ESTIMATED PERCENTAGE OF DISSIMILAR INCLUSIONS: 5%

SOIL PROFILE DESCRIPTIONS- horizon designation, depth, soil texture, Munsell color notation, Munsell color of redox features, soil structure, soil consistence, estimated coarse fragments, estimated seasonal high water table (ESHWT), observed water table (OBSWT), kind of water table (perched, apparent, or both), depth to lithic or paralithic contact:

Test Pit No. 5

ESHWT: 30"

Termination @ 36"

Refusal: 36"

Obs. Water: none

SCS Soil:

Chatfield variant

Depth	Color	Texture	Structure	Consistence	Redox; Quantity/Contrast
0-8"	10YR 3/2	FSL	GR	FR	NONE
8-30"	10YR 4/6	FSL	GR	FR	NONE
30-36"	2.5Y 5/3	FSL	GR	FR	10% Distinct

ESHWT is 30", no OBSWT, lithic contact at 36", 20% rock fragments.

SITE-SPECIFIC MAP UNIT: 699

CORRELATED SOIL SERIES: Urban land

LANDSCAPE SETTING: Top of slope adjacent to Sagamore Avenue.

CHARACTERISTIC SURFACE FEATURES: Impervious.

DRAINAGE CLASS: N/A

PARENT MATERIAL: N/A

NATURE OF DISSIMILAR INCLUSIONS: N/A

ESTIMATED PERCENTAGE OF DISSIMILAR INCLUSIONS: N/A

SOIL PROFILE DESCRIPTIONS- horizon designation, depth, soil texture, Munsell color notation, Munsell color of redox features, soil structure, soil consistence, estimated coarse fragments, estimated seasonal high water table (ESHW), observed water table (OSWT), kind of water table (perched, apparent, or both), depth to lithic or paralithic contact:

N/A ---- Pavement and buildings.



8. RESPONSIBLE SOIL SCIENTIST

Name: James Gove

Certified Soil Scientist Number: 004

9. OTHER DISTINGUISHING FEATURES OF SITE

Is the site in a natural condition? Yes, with exception of existing development.

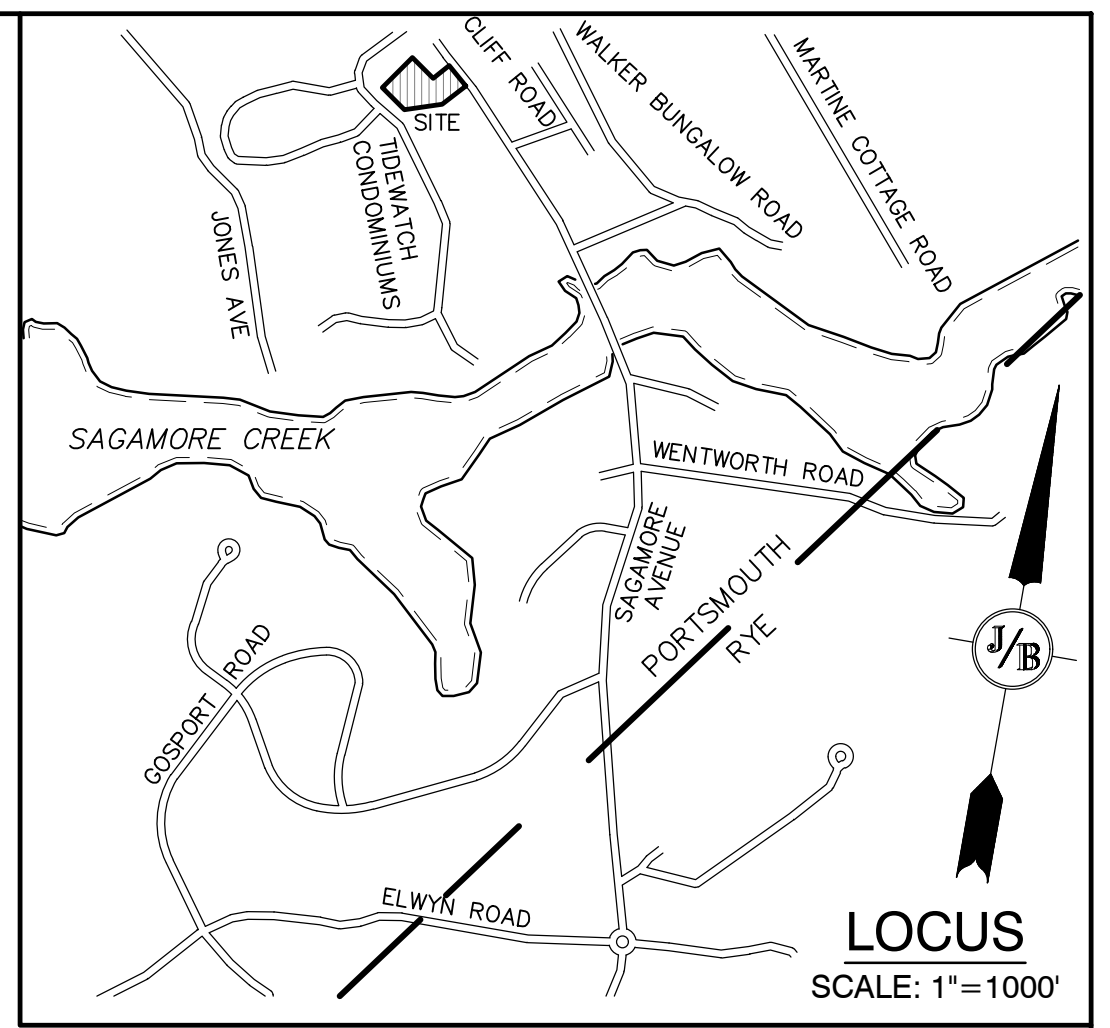
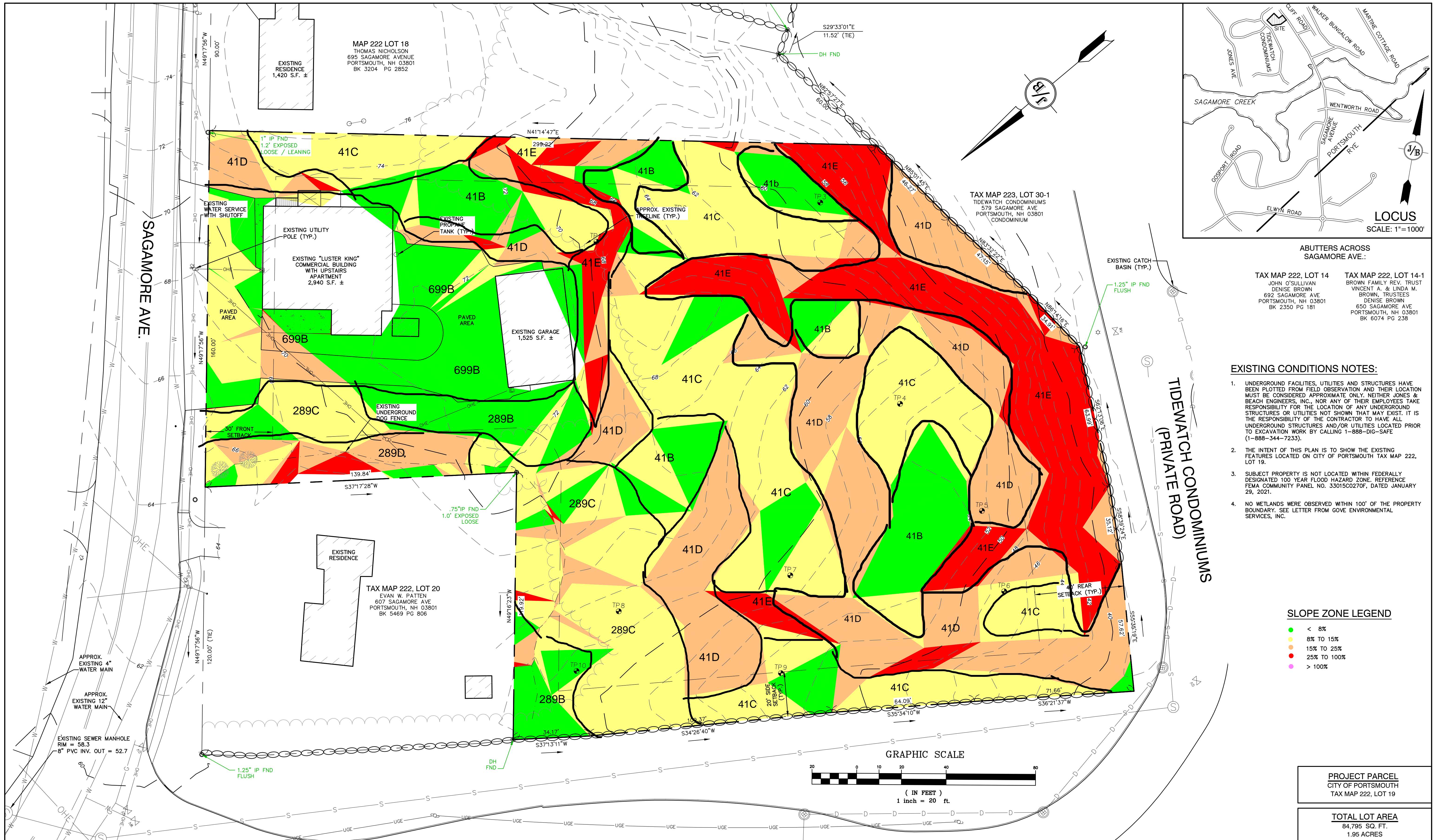

ABUTTERS ACROSS SAGAMORE AVE.:

TAX MAP 222, LOT 14
JOHN O'SULLIVAN
DENISE BROWN
692 SAGAMORE AVE
PORTSMOUTH, NH 03801
BK 2350 PG 181

TAX MAP 222, LOT 14-1
BROWN FAMILY REV. TRUST
VINCENT A. & LINDA M. BROWN, TRUSTEES
DENISE BROWN
650 SAGAMORE AVE
PORTSMOUTH, NH 03801
BK 6074 PG 238

- EXISTING CONDITIONS NOTES:**
- UNDERGROUND FACILITIES, UTILITIES AND STRUCTURES HAVE BEEN PLOTTED FROM FIELD OBSERVATION AND THEIR LOCATION MUST BE CONSIDERED APPROXIMATE ONLY. NEITHER JONES & BEACH ENGINEERS, INC., NOR ANY OF THEIR EMPLOYEES TAKE RESPONSIBILITY FOR THE LOCATION OF ANY UNDERGROUND STRUCTURES OR UTILITIES NOT SHOWN THAT MAY EXIST. IT IS THE RESPONSIBILITY OF THE CONTRACTOR TO HAVE ALL UNDERGROUND STRUCTURES AND/OR UTILITIES LOCATED PRIOR TO EXCAVATION WORK BY CALLING 1-888-DIG-SAFE (1-888-344-7233).
 - THE INTENT OF THIS PLAN IS TO SHOW THE EXISTING FEATURES LOCATED ON CITY OF PORTSMOUTH TAX MAP 222, LOT 19.
 - SUBJECT PROPERTY IS NOT LOCATED WITHIN FEDERALLY DESIGNATED 100 YEAR FLOOD HAZARD ZONE, REFERENCE FEMA COMMUNITY PANEL NO. 3301500270F, DATED JANUARY 29, 2021.
 - NO WETLANDS WERE OBSERVED WITHIN 100' OF THE PROPERTY BOUNDARY. SEE LETTER FROM GOVE ENVIRONMENTAL SERVICES, INC.

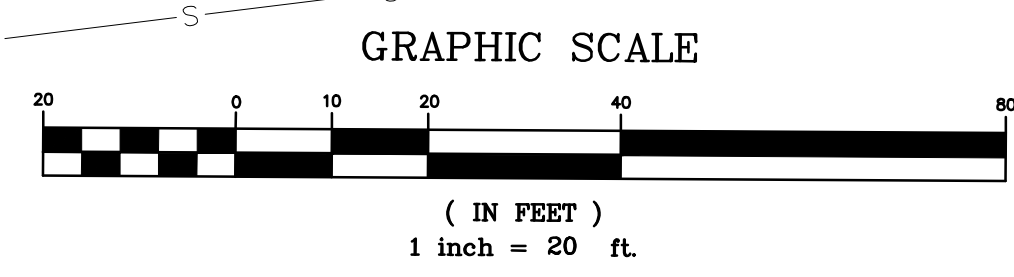
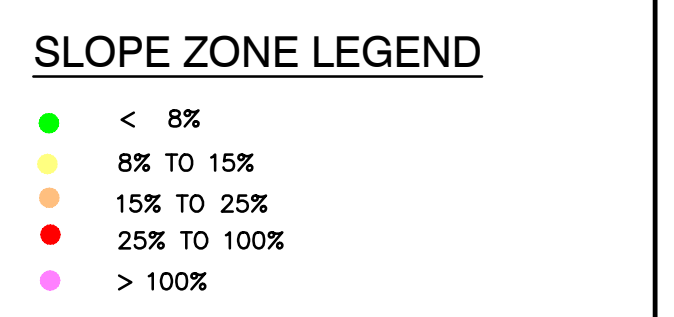

PROJECT PARCEL
CITY OF PORTSMOUTH
TAX MAP 222, LOT 19

TOTAL LOT AREA
84,795 SQ. FT.
1.95 ACRES

Design: JAC Draft: DJM Date: 12/07/2021
Checked: JAC Scale: AS NOTED Project No.: 18134.1
Drawing Name: 18134-CONCEPT-8.dwg

THIS PLAN SHALL NOT BE MODIFIED WITHOUT WRITTEN PERMISSION FROM JONES & BEACH ENGINEERS, INC. (JBE). ANY ALTERATIONS, AUTHORIZED OR OTHERWISE, SHALL BE AT THE USER'S SOLE RISK AND WITHOUT LIABILITY TO JBE.

REV.	DATE	REVISION	BY
11	1/31/24	MINOR REVISIONS TO SIGHT DISTANCE PLAN AND PROFILE	DJM
10	10/27/23	MINOR REVISIONS	DJM
9	10/20/23	MINOR REVISIONS	DJM
8	9/27/23	REVISED PER TAC COMMENTS	DJM
7	9/5/23	ISSUED TO TAC	DJM
REV.	DATE	REVISION	BY

Designed and Produced in NH

J/B Jones & Beach Engineers, Inc.

85 Portsmouth Ave. Civil Engineering Services 603-772-4746
PO Box 219 Stratham, NH 03885 FAX: 603-772-0227
E-MAIL: JBE@JONESANDBEACH.COM

Plan Name: **EXISTING CONDITIONS PLAN**

Project: **4-UNIT RESIDENTIAL SITE
635 SAGAMORE AVE., PORTSMOUTH, NH**

Owner of Record: 3612 LAFAYETTE RD., DEPT 4, PORTSMOUTH, NH 03801 BK 6332 PG 1158

DRAWING No.
C1

SHEET 2 OF 8
JBE PROJECT NO. 18134.1

APPENDIX V

NRCS Soil Map

Soil Map—Rockingham County, New Hampshire
(635 Sagamore Ave.)



Map Scale: 1:893 if printed on A landscape (11" x 8.5") sheet.

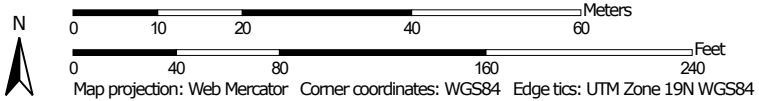

MAP LEGEND

Area of Interest (AOI)

 Area of Interest (AOI)

Soils

 Soil Map Unit Polygons

 Soil Map Unit Lines

 Soil Map Unit Points

Special Point Features



Blowout



Borrow Pit



Clay Spot



Closed Depression



Gravel Pit



Gravelly Spot



Landfill



Lava Flow



Marsh or swamp



Mine or Quarry



Miscellaneous Water



Perennial Water



Rock Outcrop



Saline Spot



Sandy Spot



Severely Eroded Spot



Sinkhole



Slide or Slip



Sodic Spot



Spoil Area



Stony Spot



Very Stony Spot



Wet Spot



Other



Special Line Features

Water Features



Streams and Canals

Transportation



Rails



Interstate Highways



US Routes



Major Roads



Local Roads

Background



Aerial Photography

MAP INFORMATION

The soil surveys that comprise your AOI were mapped at 1:24,000.

Warning: Soil Map may not be valid at this scale.

Enlargement of maps beyond the scale of mapping can cause misunderstanding of the detail of mapping and accuracy of soil line placement. The maps do not show the small areas of contrasting soils that could have been shown at a more detailed scale.

Please rely on the bar scale on each map sheet for map measurements.

Source of Map: Natural Resources Conservation Service

Web Soil Survey URL:

Coordinate System: Web Mercator (EPSG:3857)

Maps from the Web Soil Survey are based on the Web Mercator projection, which preserves direction and shape but distorts distance and area. A projection that preserves area, such as the Albers equal-area conic projection, should be used if more accurate calculations of distance or area are required.

This product is generated from the USDA-NRCS certified data as of the version date(s) listed below.

Soil Survey Area: Rockingham County, New Hampshire

Survey Area Data: Version 26, Aug 22, 2023

Soil map units are labeled (as space allows) for map scales 1:50,000 or larger.

Date(s) aerial images were photographed: Jun 19, 2020—Sep 20, 2020

The orthophoto or other base map on which the soil lines were compiled and digitized probably differs from the background imagery displayed on these maps. As a result, some minor shifting of map unit boundaries may be evident.

Map Unit Legend

Map Unit Symbol	Map Unit Name	Acres in AOI	Percent of AOI
140B	Chatfield-Hollis-Canton complex, 0 to 8 percent slopes, rocky	0.7	30.5%
140D	Chatfield-Hollis-Canton complex, 15 to 35 percent slopes, rocky	1.6	69.5%
Totals for Area of Interest		2.3	100.0%

APPENDIX VI

Extreme Precipitation Estimates

Extreme Precipitation in New York & New England

An Interactive Web Tool for Extreme Precipitation Analysis

About this Project

Data & Products

Daily Monitoring

Documentation

Select Product ?

Extreme Precipitation Tables - HTML ?

Extreme Precipitation Tables - Text/CSV ?

Partial Duration Series - by Point ?

Partial Duration Series - by Station ?

Distribution Curves - Graphical ?

Distribution Curves - Text/TBL ?

Intensity Frequency Duration Graphs ?

Precipitation Frequency Duration Graphs ?

GIS Data Files ?

Regional/State Maps ?

Select Location ? Double-click map to place a marker, or enter address or latitude/longitude.

Hybrid	Map	Locate by Address ?	Locate by Lat/Lon ?	Locate by State/County ?
Satellite	Terrain	635 Sagamore Avenue, <input type="text"/>	43.051°N -70.75°W <input type="text"/>	<input type="text" value=""/>



Select Options ?

Smoothing ? <input type="text" value="Yes"/>	Delivery ? <input type="text" value="Popup"/>
--	---

Submit ?

Extreme Precipitation Tables

Northeast Regional Climate Center

Data represents point estimates calculated from partial duration series. All precipitation amounts are displayed in inches.

Metadata for Point	
Smoothing State	Yes
Location	
Latitude	43.058 degrees North
Longitude	70.753 degrees West
Elevation	10 feet
Date/Time	Wed Feb 21 2024 09:41:54 GMT-0500 (Eastern Standard Time)

+15% due to location in Coastal/Great Bay Region

2yr: $3.22 * 1.15 = 3.70$ in

10yr: $4.88 * 1.15 = 5.61$ in

25yr: $6.19 * 1.15 = 7.12$ in

50yr: $7.42 * 1.15 = 8.53$ in

Extreme Precipitation Estimates

	5min	10min	15min	30min	60min	120min		1hr	2hr	3hr	6hr	12hr	24hr	48hr		1day	2day	4day	7day	10day
1yr	0.26	0.40	0.50	0.65	0.82	1.04	1yr	0.70	0.98	1.21	1.56	2.03	2.67	2.94	1yr	2.36	2.82	3.24	3.96	4.57
2yr	0.32	0.50	0.62	0.82	1.03	1.30	2yr	0.89	1.18	1.52	1.94	2.49	3.22	3.58	2yr	2.85	3.45	3.95	4.70	5.35
5yr	0.37	0.58	0.73	0.98	1.25	1.61	5yr	1.08	1.47	1.89	2.44	3.15	4.08	4.60	5yr	3.61	4.42	5.07	5.96	6.73
10yr	0.41	0.65	0.82	1.12	1.46	1.90	10yr	1.26	1.73	2.24	2.90	3.76	4.88	5.55	10yr	4.32	5.34	6.12	7.14	8.01
25yr	0.48	0.76	0.97	1.34	1.78	2.35	25yr	1.54	2.15	2.79	3.65	4.76	6.19	7.13	25yr	5.48	6.86	7.85	9.07	10.09
50yr	0.54	0.86	1.11	1.55	2.08	2.77	50yr	1.80	2.54	3.31	4.35	5.69	7.42	8.62	50yr	6.57	8.29	9.48	10.87	12.02
100yr	0.60	0.97	1.25	1.78	2.43	3.28	100yr	2.10	2.99	3.93	5.19	6.80	8.89	10.42	100yr	7.87	10.02	11.46	13.04	14.33
200yr	0.68	1.11	1.44	2.06	2.85	3.86	200yr	2.46	3.54	4.65	6.17	8.12	10.65	12.60	200yr	9.43	12.12	13.85	15.64	17.09
500yr	0.81	1.33	1.73	2.51	3.51	4.80	500yr	3.03	4.41	5.81	7.76	10.28	13.54	16.21	500yr	11.98	15.59	17.81	19.90	21.58

Lower Confidence Limits

	5min	10min	15min	30min	60min	120min		1hr	2hr	3hr	6hr	12hr	24hr	48hr		1day	2day	4day	7day	10day
1yr	0.23	0.36	0.44	0.59	0.72	0.88	1yr	0.62	0.86	0.93	1.33	1.69	2.26	2.51	1yr	2.00	2.41	2.88	3.20	3.93
2yr	0.32	0.49	0.60	0.81	1.00	1.19	2yr	0.86	1.16	1.37	1.82	2.33	3.07	3.47	2yr	2.72	3.33	3.84	4.56	5.11
5yr	0.35	0.54	0.67	0.92	1.17	1.40	5yr	1.01	1.37	1.61	2.11	2.73	3.80	4.21	5yr	3.36	4.05	4.74	5.56	6.27
10yr	0.39	0.59	0.74	1.03	1.33	1.60	10yr	1.15	1.57	1.81	2.38	3.05	4.39	4.88	10yr	3.88	4.70	5.48	6.45	7.23
25yr	0.44	0.67	0.83	1.19	1.57	1.90	25yr	1.35	1.86	2.10	2.74	3.52	4.77	5.92	25yr	4.22	5.70	6.70	7.85	8.73
50yr	0.48	0.73	0.92	1.32	1.77	2.17	50yr	1.53	2.12	2.35	3.06	3.91	5.40	6.84	50yr	4.78	6.58	7.79	9.11	10.08
100yr	0.54	0.81	1.02	1.47	2.02	2.47	100yr	1.74	2.42	2.63	3.39	4.33	6.08	7.90	100yr	5.38	7.60	9.07	10.60	11.64
200yr	0.59	0.89	1.13	1.64	2.29	2.82	200yr	1.97	2.75	2.94	3.75	4.76	6.83	9.12	200yr	6.05	8.77	10.54	12.34	13.47
500yr	0.69	1.02	1.32	1.92	2.72	3.37	500yr	2.35	3.29	3.42	4.28	5.41	7.97	11.03	500yr	7.06	10.61	12.87	15.13	16.32

Upper Confidence Limits

	5min	10min	15min	30min	60min	120min		1hr	2hr	3hr	6hr	12hr	24hr	48hr		1day	2day	4day	7day	10day
1yr	0.29	0.44	0.54	0.72	0.89	1.08	1yr	0.77	1.06	1.26	1.74	2.20	2.99	3.18	1yr	2.64	3.05	3.59	4.38	5.06
2yr	0.34	0.52	0.64	0.87	1.07	1.27	2yr	0.92	1.24	1.48	1.96	2.51	3.43	3.72	2yr	3.03	3.57	4.10	4.86	5.64
5yr	0.40	0.62	0.77	1.05	1.34	1.63	5yr	1.16	1.59	1.89	2.54	3.25	4.36	4.98	5yr	3.85	4.79	5.40	6.40	7.18
10yr	0.47	0.72	0.89	1.25	1.61	1.98	10yr	1.39	1.94	2.29	3.11	3.96	5.36	6.22	10yr	4.74	5.98	6.84	7.87	8.78
25yr	0.58	0.88	1.09	1.56	2.06	2.58	25yr	1.77	2.52	2.96	4.08	5.17	7.77	8.36	25yr	6.87	8.04	9.18	10.37	11.44
50yr	0.67	1.03	1.28	1.84	2.48	3.15	50yr	2.14	3.08	3.61	5.01	6.35	9.71	10.48	50yr	8.60	10.08	11.48	12.76	14.00
100yr	0.80	1.20	1.51	2.17	2.98	3.83	100yr	2.57	3.75	4.39	6.18	7.80	12.14	13.13	100yr	10.74	12.62	14.35	15.74	17.13
200yr	0.93	1.40	1.78	2.57	3.58	4.69	200yr	3.09	4.58	5.36	7.61	9.60	15.22	16.46	200yr	13.47	15.83	17.96	19.40	20.96
500yr	1.16	1.72	2.22	3.22	4.58	6.09	500yr	3.95	5.95	6.96	10.07	12.65	20.54	22.22	500yr	18.18	21.36	24.18	25.57	27.38

APPENDIX VII

Rip Rap Calculations

RIP RAP CALCULATIONS

"Luster Cluster"
635 Sagamore Ave.
Portsmouth, NH

Jones & Beach Engineers, Inc.

P.O. Box 219
Stratham, NH 03885
3/14/2024 REVISED 4/19/2024

Rip Rap equations were obtained from the *Stormwater Management and Erosion Control Handbook for Urban and Developing Areas in New Hampshire*.

Aprons are sized for the 10-Year storm event.

TAILWATER < HALF THE D_o

$$L_a = (1.8 \times Q) / D_o^{3/2} + (7 \times D_o)$$

$$W = L_a + (3 \times D_o) \text{ or defined channel width}$$

$$d_{50} = (0.02 \times Q^{4/3}) / (T_w \times D_o)$$

Culvert or Catch Basin (Sta. No.)	Tailwater (Feet) T _w	Discharge (C.F.S.) Q	Diameter of Pipe D _o	Length of Rip Rap L _a (feet)	Width of Rip Rap W (feet)	d ₅₀ -Median Stone Rip Rap d50 (feet)
1P Outlet Pipe	0.12	0.21	1	7.4	10	0.02

TAILWATER > HALF THE D_o

$$L_a = (3.0 \times Q) / D_o^{3/2} + (7 \times D_o)$$

$$W = (0.4 \times L_a) + (3 \times D_o) \text{ or defined channel width}$$

$$d_{50} = (0.02 \times Q^{4/3}) / (T_w \times D_o)$$

Culvert or Catch Basin (Sta. No.)	Tailwater (Feet) T _w	Discharge (C.F.S.) Q	Diameter of Pipe D _o	Length of Rip Rap L _a (feet)	Width of Rip Rap W (feet)	d ₅₀ -Median Stone Rip Rap d50 (feet)
CB4 Outlet Pipe	0.66	2.41	1	14.2	9	0.10

Table 7-24 -- Recommended Rip Rap Gradation Ranges			
d_{50} Size =	0.25	Feet	3 Inches
% of Weight Smaller Than the Given d_{50} Size	Size of Stone (Inches)		
	From	To	
100%	5	6	
85%	4	5	
50%	3	5	
15%	1	2	

Table 7-24 -- Recommended Rip Rap Gradation Ranges			
d_{50} Size =	0.5	Feet	6 Inches
% of Weight Smaller Than the Given d_{50} Size	Size of Stone (Inches)		
	From	To	
100%	9	12	
85%	8	11	
50%	6	9	
15%	2	3	

APPENDIX VIII

BMP Worksheets



FILTRATION PRACTICE DESIGN CRITERIA (Env-Wq 1508.07)

Type/Node Name: _____

Bioretention Pond (1P)

Enter the type of filtration practice (e.g., bioretention system) and the node name in the drainage analysis, if applicable.

		Check if you reviewed the restrictions on unlined systems outlined in Env-Wq 1508.07(a).	
0.65	ac	A = Area draining to the practice	
0.29	ac	A _i = Impervious area draining to the practice	
0.45	decimal	l = Percent impervious area draining to the practice, in decimal form	
0.46	unitless	Rv = Runoff coefficient = 0.05 + (0.9 x l)	
0.30	ac-in	WQV = 1" x Rv x A	
1,076	cf	WQV conversion (ac-in x 43,560 sf/ac x 1ft/12")	
269	cf	25% x WQV (check calc for sediment forebay volume)	
807	cf	75% x WQV (check calc for surface sand filter volume)	
Deep Sump CBs		Method of Pretreatment? (not required for clean or roof runoff)	
	cf	V _{SED} = Sediment forebay volume, if used for pretreatment	≥ 25%WQV
Calculate time to drain if system IS NOT underdrained:			
	sf	A _{SA} = Surface area of the practice	
	iph	K _{sat} _{DESIGN} = Design infiltration rate ¹	
	Yes/No	If K _{sat} (prior to factor of safety) is < 0.50 iph, has an underdrain been provided? (Use the calculations below)	
-	hours	T _{DRAIN} = Drain time = V / (A _{SA} * I _{DESIGN})	≤ 72-hrs
Calculate time to drain if system IS underdrained:			
61.15	ft	E _{WQV} = Elevation of WQV (attach stage-storage table)	
0.11	cfs	Q _{WQV} = Discharge at the E _{WQV} (attach stage-discharge table)	
5.44	hours	T _{DRAIN} = Drain time = 2WQV/Q _{WQV}	≤ 72-hrs
59.10	feet	E _{FC} = Elevation of the bottom of the filter course material ²	
58.60	feet	E _{UD} = Invert elevation of the underdrain (UD), if applicable	
58.08	feet	E _{SHWT} = Elevation of SHWT (if none found, enter the lowest elevation of the test pit)	
55.83	feet	E _{ROCK} = Elevation of bedrock (if none found, enter the lowest elevation of the test pit)	
0.50	feet	D _{FC to UD} = Depth to UD from the bottom of the filter course	≥ 1'
3.27	feet	D _{FC to ROCK} = Depth to bedrock from the bottom of the filter course	≥ 1'
1.02	feet	D _{FC to SHWT} = Depth to SHWT from the bottom of the filter course	≥ 1'
62.85	ft	Peak elevation of the 50-year storm event (infiltration can be used in analysis)	
63.00	ft	Elevation of the top of the practice	
YES		50 peak elevation ≤ Elevation of the top of the practice	← yes
If a surface sand filter or underground sand filter is proposed:			
YES	ac	Drainage Area check.	< 10 ac
	cf	V = Volume of storage ³ (attach a stage-storage table)	≥ 75%WQV
	inches	D _{FC} = Filter course thickness	18", or 24" if within GPA
Sheet		Note what sheet in the plan set contains the filter course specification.	
8	Yes/No	Access grate provided?	← yes

If a bioretention area is proposed:			
YES	ac	Drainage Area no larger than 5 ac?	← yes
4,806	cf	V = Volume of storage ³ (attach a stage-storage table)	≥ WQV
18.0	inches	D _{FC} = Filter course thickness	18", or 24" if within GPA
Sheet	D4	Note what sheet in the plan set contains the filter course specification	
3.0	:1	Pond side slopes	> 3:1
Sheet	D4	Note what sheet in the plan set contains the planting plans and surface cover	
If porous pavement is proposed:			
		Type of pavement proposed (Concrete? Asphalt? Pavers? Etc.)	
	acres	A _{SA} = Surface area of the pervious pavement	
	:1	Ratio of the contributing area to the pervious surface area	≤ 5:1
	inches	D _{FC} = Filter course thickness	12", or 18" if within GPA
Sheet		Note what sheet in the plan set contains the filter course spec.	mod. 304.1 (see spec)

1. Rate of the limiting layer (either the filter course or the underlying soil). K_{sat_design} includes factor of safety. See Env-Wq 1504.14 for guidance on determining the infiltration rate.
2. See lines 34, 40 and 48 for required depths of filter media.
3. Volume without depending on infiltration. The volume includes the storage above the filter (but below the invert of the outlet structure, if any), the filter media voids, and the pretreatment area. The storage above the filter media shall not include the volume above the outlet structure, if any.

Designer's Notes: _____

SHWT elevation at high contour is only 0.01' below the bottom of the stone. However, we modelled it 2" lower in the HydroCAD calculations as a factor of safety. Modelling such a small separation from the bottom of the stone to the SHWT causes an unrealistically high amount of exfiltration to appear in the results.

18134-PROPOSED

Type III 24-hr 50 Yr 24 Hr +15% Rainfall=8.53"

Prepared by Jones & Beach Engineers Inc

Printed 4/19/2024

HydroCAD® 10.20-3c s/n 00762 © 2023 HydroCAD Software Solutions LLC

Page 2

Stage-Area-Storage for Pond 1P: Bioretention Pond

Elevation (feet)	Surface (sq-ft)	Storage (cubic-feet)	Elevation (feet)	Surface (sq-ft)	Storage (cubic-feet)
58.09	466	0	60.69	733	349
58.14	466	9	60.74	907	390
58.19	466	19	60.79	1,100	440
58.24	466	28	60.84	1,312	501
58.29	466	37	60.89	1,542	572
58.34	466	47	60.94	1,791	655
58.39	466	56	60.99	2,058	751
58.44	466	65	61.04	2,135	857
58.49	466	75	61.09	2,162	965
58.54	466	84	61.14	2,188	1,073
58.59	466	93	61.19	2,215	1,183
58.64	466	103	61.24	2,242	1,295
58.69	466	112	61.29	2,269	1,408
58.74	466	121	61.34	2,296	1,522
58.79	466	130	61.39	2,324	1,637
58.84	466	140	61.44	2,351	1,754
58.89	466	149	61.49	2,379	1,872
58.94	466	158	61.54	2,407	1,992
58.99	466	168	61.59	2,435	2,113
59.04	466	177	61.64	2,464	2,236
59.09	466	186	61.69	2,492	2,360
59.14	466	190	61.74	2,521	2,485
59.19	466	193	61.79	2,549	2,612
59.24	466	197	61.84	2,578	2,740
59.29	466	200	61.89	2,607	2,869
59.34	466	204	61.94	2,637	3,001
59.39	466	207	61.99	2,666	3,133
59.44	466	211	62.04	2,695	3,267
59.49	466	214	62.09	2,725	3,403
59.54	466	218	62.14	2,754	3,540
59.59	466	221	62.19	2,784	3,678
59.64	466	225	62.24	2,813	3,818
59.69	466	228	62.29	2,843	3,959
59.74	466	232	62.34	2,873	4,102
59.79	466	235	62.39	2,904	4,247
59.84	466	239	62.44	2,934	4,393
59.89	466	242	62.49	2,964	4,540
59.94	466	246	62.54	2,995	4,689
59.99	466	249	62.59	3,026	4,840
60.04	466	253	62.64	3,057	4,992
60.09	466	256	62.69	3,088	5,145
60.14	466	260	62.74	3,120	5,301
60.19	466	263	62.79	3,151	5,457
60.24	466	267	62.84	3,183	5,616
60.29	466	270	62.89	3,214	5,776
60.34	466	274	62.94	3,246	5,937
60.39	466	277	62.99	3,279	6,100
60.44	466	281			
60.49	466	284			
60.54	466	288			
60.59	466	291			
60.64	577	317			

End cap inv. = 58.9
Vol. below = 149 cf for GRV calculation

WQV Required = 1,076 cf
WQV El. = 61.15

Overflow el. = 62.65
Vol. below = 4,992 cf

Bottom of filter course el. = 59.1

4992-186 = 4,806 cf

WQV Provided = 4,806 cf
>> 1,076 cf

End cap invert

WQV El.

Overflow

18134-PROPOSED

Type III 24-hr 50 Yr 24 Hr +15% Rainfall=8.53"

Prepared by Jones & Beach Engineers Inc

Printed 4/19/2024

HydroCAD® 10.20-3c s/n 00762 © 2023 HydroCAD Software Solutions LLC

Page 1

Stage-Discharge for Pond 1P: Bioretention Pond

Elevation (feet)	Discharge (cfs)	Discarded (cfs)	Primary (cfs)	Elevation (feet)	Discharge (cfs)	Discarded (cfs)	Primary (cfs)
58.09	0.00	0.00	0.00	60.69	0.09	0.05	0.03
58.14	0.00	0.00	0.00	60.74	0.09	0.06	0.04
58.19	0.01	0.01	0.00	60.79	0.09	0.06	0.04
58.24	0.01	0.01	0.00	60.84	0.10	0.06	0.04
58.29	0.01	0.01	0.00	60.89	0.10	0.06	0.04
58.34	0.01	0.01	0.00	60.94	0.10	0.07	0.04
58.39	0.01	0.01	0.00	60.99	0.11	0.07	0.04
58.44	0.01	0.01	0.00	61.04	0.11	0.07	0.04
58.49	0.01	0.01	0.00	61.09	0.11	0.07	0.04
58.54	0.01	0.01	0.00	61.14	0.11	0.07	0.04
58.59	0.01	0.01	0.00	61.19	0.12	0.08	0.04
58.64	0.01	0.01	0.00	61.24	0.12	0.08	0.04
58.69	0.01	0.01	0.00	61.29	0.12	0.08	0.04
58.74	0.02	0.02	0.00	61.34	0.12	0.08	0.04
58.79	0.02	0.02	0.00	61.39	0.12	0.08	0.04
58.84	0.02	0.02	0.00	61.44	0.12	0.08	0.04
58.89	0.02	0.02	0.00	61.49	0.13	0.08	0.04
58.94	0.02	0.02	0.00	61.54	0.13	0.09	0.04
58.99	0.03	0.02	0.01	61.59	0.13	0.09	0.04
59.04	0.03	0.02	0.01	61.64	0.13	0.09	0.04
59.09	0.03	0.02	0.01	61.69	0.13	0.09	0.04
59.14	0.03	0.02	0.01	61.74	0.13	0.09	0.04
59.19	0.04	0.02	0.01	61.79	0.14	0.09	0.04
59.24	0.04	0.03	0.01	61.84	0.14	0.09	0.04
59.29	0.04	0.03	0.02	61.89	0.14	0.09	0.05
59.34	0.04	0.03	0.02	61.94	0.14	0.10	0.05
59.39	0.05	0.03	0.02	61.99	0.14	0.10	0.05
59.44	0.05	0.03	0.02	62.04	0.15	0.10	0.05
59.49	0.05	0.03	0.02	62.09	0.15	0.10	0.05
59.54	0.05	0.03	0.02	62.14	0.15	0.10	0.05
59.59	0.05	0.03	0.02	62.19	0.15	0.10	0.05
59.64	0.05	0.03	0.02	62.24	0.15	0.10	0.05
59.69	0.06	0.03	0.02	62.29	0.15	0.11	0.05
59.74	0.06	0.03	0.02	62.34	0.16	0.11	0.05
59.79	0.06	0.04	0.02	62.39	0.16	0.11	0.05
59.84	0.06	0.04	0.02	62.44	0.16	0.11	0.05
59.89	0.06	0.04	0.03	62.49	0.16	0.11	0.05
59.94	0.06	0.04	0.03	62.54	0.16	0.11	0.05
59.99	0.07	0.04	0.03	62.59	0.16	0.11	0.05
60.04	0.07	0.04	0.03	62.64	0.17	0.12	0.05
60.09	0.07	0.04	0.03	62.69	0.27	0.12	0.15
60.14	0.07	0.04	0.03	62.74	0.52	0.12	0.40
60.19	0.07	0.04	0.03	62.79	0.84	0.12	0.72
60.24	0.07	0.04	0.03	62.84	1.24	0.12	1.12
60.29	0.08	0.05	0.03	62.89	1.69	0.12	1.56
60.34	0.08	0.05	0.03	62.94	2.18	0.13	2.06
60.39	0.08	0.05	0.03	62.99	2.73	0.13	2.60
60.44	0.08	0.05	0.03				
60.49	0.08	0.05	0.03				
60.54	0.08	0.05	0.03				
60.59	0.08	0.05	0.03				
60.64	0.09	0.05	0.03				

WQV El. = 61.15
Q(WQV) = 0.11 cfs



GROUNDWATER RECHARGE VOLULME (GRV) CALCULATION
(Env-Wq 1507.04)

	ac	Area of HSG A soil that was replaced by impervious cover	0.40"
0.12	ac	Area of HSG B soil that was replaced by impervious cover	0.25"
	ac	Area of HSG C soil that was replaced by impervious cover	0.10"
	ac	Area of HSG D soil or impervious cover that was replaced by impervious cover	0.0"
0.25 inches		Rd = Weighted groundwater recharge depth	
0.031 ac-in		GRV = AI * Rd	
113 cf		GRV conversion (ac-in x 43,560 sf/ac x 1ft/12")	

Provide calculations below showing that the project meets the groundwater recharge requirements (Env-Wq 1507.04):

Stone Drip Edges, 40% Stone Voids:

$((3\text{ ft} * 60\text{ ft} * 3.5\text{ ft}) + (3\text{ ft} * 60\text{ ft} * 4.5\text{ ft})) * 0.4 = 576\text{ cf}$

Eco Paver, 40% Voids: $(13\text{ ft} * 17\text{ ft} * 1\text{ ft}) * 0.4 = 88\text{ cf}$

Stone Beneath Deck: $(14\text{ ft} * 20\text{ ft} * 1.5\text{ ft}) * 0.4 = 168\text{ cf}$

Bioretention: 149 cf GRV provided below UD end cap orifice per stage storage table

GRV Provided = $576 + 88 + 168 + 149 = 981\text{ cf} \gg 113\text{ cf}$

APPENDIX IX

Pollutant Removal Calculations

POLLUTANT REMOVAL CALCULATIONS

BMP	Drip Edge	Bioretention	None	Total	Required
Acres Impervious	0.032	0.293	0.036	0.361	
TSS Removal (%)	90%	90%	0%	81%	80%
TN Removal (%)	55%	65%	0%	68%	50%

Calculations are based on post-construction impervious surfaces on the subject parcel.

TSS removal of 86% provided exceeds 80% requirement

TN removal of 65% provided exceeds 50% requirement

Pollutant Removal Efficiencies for Best Management Practices for Use in Pollutant Loading Analysis				Values Accepted for Loading Analyses		
BMP Type	BMP	Notes	Lit. Ref.	TSS	TN	TP
Stormwater Ponds	Wet Pond		B, F	70%	35%	45%
	Wet Extended Detention Pond		A, B	80%	55%	68%
	Micropool Extended Detention Pond	TBA				
	Multiple Pond System	TBA				
	Pocket Pond	TBA				
Stormwater Wetlands	Shallow Wetland		A, B, F, I	80%	55%	45%
	Extended Detention Wetland		A, B, F, I	80%	55%	45%
	Pond/Wetland System	TBA				
	Gravel Wetland		H	95%	85%	64%
Infiltration Practices	Infiltration Trench (≥ 75 ft from surface water)		B, D, I	90%	55%	60%
	Infiltration Trench (< 75 ft from surface water)		B, D, I	90%	10%	60%
	Infiltration Basin (≥ 75 ft from surface water)		A, F, B, D, I	90%	60%	65%
	Infiltration Basin (< 75 ft from surface water)		A, F, B, D, I	90%	10%	65%
	Dry Wells			90%	55%	60%
	Drip Edges			90%	55%	60%
Filtering Practices	Aboveground or Underground Sand Filter that infiltrates WQV (≥ 75 ft from surface water)		A, F, B, D, I	90%	60%	65%
	Aboveground or Underground Sand Filter that infiltrates WQV (< 75 ft from surface water)		A, F, B, D, I	90%	10%	65%
	Aboveground or Underground Sand Filter with underdrain		A, I, F, G, H	85%	10%	45%
	Tree Box Filter	TBA				
	Bioretention System		I, G, H	90%	65%	65%
	Permeable Pavement that infiltrates WQV (≥ 75 ft from surface water)		A, F, B, D, I	90%	60%	65%
	Permeable Pavement that infiltrates WQV (< 75 ft from surface water)		A, F, B, D, I	90%	10%	65%
	Permeable Pavement with underdrain		Use TN and TP values for sand filter w/ underdrain and outlet pipe	90%	10%	45%

Pollutant Removal Efficiencies for Best Management Practices for Use in Pollutant Loading Analysis				Values Accepted for Loading Analyses		
BMP Type	BMP	Notes	Lit. Ref.	TSS	TN	TP
Treatment Swales	Flow Through Treatment Swale	TBA				
Vegetated Buffers	Vegetated Buffers		A, B, I	73%	40%	45%
Pre-Treatment Practices	Sediment Forebay	TBA				
	Vegetated Filter Strip		A, B, I	73%	40%	45%
	Vegetated Swale		A, B, C, F, H, I	65%	20%	25%
	Flow-Through Device - Hydrodynamic Separator		A, B, G, H	35%	10%	5%
	Flow-Through Device - ADS Underground Multichamber Water Quality Unit (WQU)		G, H	72%	10%	9%
	Other Flow-Through Devices	TBA				
	Off-line Deep Sump Catch Basin		J, K, L, M	15%	5%	5%

APPENDIX X

Stormwater Operations and Maintenance Manual



85 Portsmouth Avenue, PO Box 219, Stratham, NH 03885
603.772.4746 - JonesandBeach.com

STORMWATER MANAGEMENT OPERATIONS AND MAINTENANCE MANUAL

**Luster Cluster
635 Sagamore Ave.
Portsmouth, NH 03801
Tax Map 222, Lot 19**

Prepared for:

**635 Sagamore Development LLC
3612 Lafayette Rd., Dept 4
Portsmouth, NH 03801**

Prepared by:

**Jones & Beach Engineers, Inc.
85 Portsmouth Avenue
P.O. Box 219
Stratham, NH 03885
(603) 772-4746
March 18, 2024
Revised April 15, 2024
JBE Project No. 18134.1**

Inspection and Maintenance of Facilities and Property

A. Maintenance of Common Facilities or Property

1. The Condominium Association, future owners and assigns are responsible to perform the maintenance obligations or hire a Professional Engineer to review the site on an annual basis for maintenance and certification of the stormwater system. The Association, future owners and assigns shall keep receipts and records of all maintenance companies hired throughout the year to submit along with the following form and shall submit an Operations and Maintenance report on a yearly basis to the Portsmouth Planning Department by December 31st.

B. General Inspection and Maintenance Requirements

1. Permanent stormwater and sediment and erosion control facilities to be maintained on the site include, but are not limited to, the following:
 - a. Roadway and driveways
 - b. Vegetation and landscaping
 - c. Bioretention systems
 - d. Catch Basins & Yard Drains
 - e. Permeable Paver Patio
 - f. Stone Drip Edges
 - g. Culverts
 - h. Rip-Rap Outlet Protection Aprons
 - i. Swale
2. Maintenance of permanent measures shall follow the following schedule:
 - a. Normal winter roadway maintenance including plowing and snow removal. Road sweeping at the end of every winter, preferably before the start of the spring rain season.
 - b. **Annual inspection** of the site for erosion, destabilization, settling, and sloughing. Any needed repairs are to be conducted immediately. **Annual inspection** of site's vegetation and landscaping. Any areas that are bare shall be reseeded and mulched with hay or, if the case is extreme, loamed and seeded or sodded to ensure adequate vegetative cover. Landscape specimens shall be replaced in kind, if they are found to be dead or dying.
 - c. Bioretention Systems:
 - Visually inspect monthly and repair erosion. Use small stones to stabilize erosion along drainage paths.
 - Check the pH once a year if grass is not surviving. Apply an alkaline product, such as limestone, if needed.
 - Re-seed any bare areas by hand as needed.

- Immediately after the completion of cell construction, water grass for 14 consecutive days unless there is sufficient natural rainfall.
- Once a month (more frequently in the summer), the land owner or Association shall visually inspect vegetation for disease or pest problems and treat as required.
- During times of extended drought, look for physical features of stress. Water in the early morning as needed.
- Weed regularly, if needed.
- After rainstorms, inspect the cell and make sure that drainage paths are clear and that ponding water dissipates over 4-6 hours. (Water may pond for longer times during the winter and early spring.)
- Twice annually, inspect the outlet control structures to ensure that they are not clogged and correct any clogging found as needed.
- Any debris and sediment accumulations shall be removed from the outlet structures, overflow risers, and emergency spillways and disposed of properly.
- Inspect outlet structure for deterioration and or clogging.
- If erosion is evident on the berm or emergency spillway, stabilize the affected area by seeding. Trees must not be allowed to grow in these areas.
- **KEEP IN MIND, THE BIORETENTION CELL IS NOT A POND. IT SHALL NOT PROVIDE A BREEDING GROUND FOR MOSQUITOES. MOSQUITOES NEED AT LEAST FOUR (4) DAYS OF STANDING WATER TO DEVELOP AS LARVA.**

d. **Annual inspection** of catch basins and yard drains to determine if they need to be cleaned. Catch basins and yard drains are to be cleaned if the depth of deposits is greater than one-half the depth from the basin bottom to the invert of the lowest pipe or opening into or out of the basin. If a catch basin or yard drain significantly exceeds the one-half depth standard during the inspection, then it shall be cleaned more frequently. If woody debris or trash accumulates in the catch basin or yard drain, then it shall be cleaned on a weekly basis. The catch basin or yard drain can be cleaned either manually or by specially designed equipment including, but not limited to, bucket loaders and vacuum pumps. Before any materials can be disposed, it is necessary to perform a detailed chemical analysis to determine if the materials meet the EPA criteria for hazardous waste. This will help determine how the materials shall be stored, treated, and disposed. Grease hoods are to be wiped clean and the rags disposed of properly. Debris obscuring the grate inlet shall also be removed.

e. **Permeable Paver Patio:**

Units 4 features a permeable paver patio for stormwater management while Units 1-3 feature standard paver patios. The following course of action will help assure that the pavers are maintained to preserve its hydrologic effectiveness for their special purpose.

Winter maintenance:

- Sanding for winter traction is prohibited. Deicing is permitted (NaCl, MgCl₂, or equivalent). Reduced salt application is possible and can be a cost savings for winter maintenance. Nontoxic, organic deicers, applied either as blended, magnesium chloride-based liquid products or as pretreated salt, are preferable.
- Plow after each storm. Special plow blades may be used to prevent scarring. Do not raise blade of plow. Ice and light snow accumulation are generally not as problematic as for standard asphalt. Snow will accumulate during heavier storms and should be plowed after 2 to 4 inches of snow accumulate. Alternatively, snow may be blown or shoveled off of paver surface

Routine maintenance:

- Seal coating is absolutely forbidden. Surface seal coating is not reversible.
- The paver surface shall be vacuumed 2 or 3 times per year, and at any additional times sediment is spilled, eroded, or tracked onto the surface.
- Planted areas adjacent to permeable pavers shall be well maintained to prevent soil washout onto the pavers. If any bare spots or eroded areas are observed within the planted areas, they shall be replanted and/or stabilized at once.
- Immediately clean any soil deposited on pavers. Superficial dirt does not necessarily clog the paver voids. However, dirt that is ground in repeatedly by tires can lead to clogging. Therefore, trucks or other heavy vehicles shall be prevented from tracking or spilling dirt onto the pavers.
- Do not allow construction staging, soil/mulch storage, etc. on unprotected paver surface. Contractor to lay down tarps, plywood or removable item and take care not to track material onto unprotected pavers.
- Repairs: Potholes or other surface blemishes shall be replaced in kind. Any required repair of drainage structures shall be done promptly to ensure continued proper functioning of the system.
- Written and verbal communication to the future owner shall make clear the pavers' special purpose and special maintenance requirements such as those listed here.

f. **Stone Drip Edges:**

In the spring and fall, visually inspect the area around the edges and repair any erosion. Use small stones to stabilize erosion along drainage paths. Inspect stone area to ensure that it has not been displaced, undermined, or otherwise damaged. Displaced rock shall be replaced, or additional rock added in order to maintain the structure(s) in their undamaged state. Woody vegetation shall not be allowed to become established in stone areas, and/or any debris removed from the void spaces between the stones.

- g. **Inspection** of culvert inlets and outlets at least **once per month** during the rainy season (March to November). Any debris is to be removed and disposed of properly.

- h. Rock riprap shall be **inspected annually** in order to ensure that it has not been displaced, undermined, or otherwise damaged. Displaced rock shall be replaced, or additional rock added in order to maintain the structure(s) in their undamaged state. Woody vegetation must not be allowed to become established in riprap areas, and/or any debris removed from the void spaces between the rocks. If the riprap is adjacent to a stream or other waterbody, the water shall be kept clear of obstructions, debris, and sediment deposits

- i. Swales - Inspect swales annually for erosion, sediment accumulation, vegetation loss, and presence of invasive species. Perform periodic mowing; frequency depends on location and type of grass. Remove debris and accumulated sediment, based on inspection. Repair eroded areas, remove invasive species and dead vegetation, and reseed as warranted by inspection

See attached sample forms as a guideline.

Any inquiries in regards to the design, function, and/or maintenance of any one of the above-mentioned facilities or tasks shall be directed to the project engineer:

Jones & Beach Engineers, Inc.
85 Portsmouth Avenue
P.O. Box 219
Stratham, NH 03885

T#: (603) 772-4746
F#: (603) 772-0227

Commitment to maintenance requirements

I agree to complete and/or observe all of the required maintenance practices and their respective schedules as outlined above.

Signature

Print Name

Title

Date

Annual Operations and Maintenance Report

The Condominium Association, future owners and assigns are responsible to perform the maintenance obligations or hire a Professional Engineer to review the site on an annual basis for maintenance and certification of the stormwater system. The Association, future owners and assigns shall keep receipts and records of all maintenance companies hired throughout the year to submit along with the following form and shall submit an Operations and Maintenance report on a yearly basis to the Portsmouth Planning Department by December 31st.

Construction Activity	Date of Inspection	Who Inspected	Findings of Inspector
Roadway and Driveways			
Vegetation and Landscaping			
Bioretention #1			
Bioretention #2			
Catch Basins & Yard Drains			

Permeable Paver Patios (Unit 4)			
Stone Drip Edge			
Culverts			
Rip Rap Outlet Protection			
Swales			
Other (please note):			

Regular Inspection and Maintenance Guidance for Bioretention Systems / Tree Filters

Maintenance of bioretention systems and tree filters can typically be performed as part of standard landscaping. Regular inspection and maintenance is critical to the effective operation of bioretention systems and tree filters to insure they remain clear of leaves and debris and free draining. This page provides guidance on maintenance activities that are typically required for these systems, along with the suggested frequency for each activity. Individual systems may have more, or less, frequent maintenance needs, depending on a variety of factors including the occurrence of large storm events, overly wet or dry (I.E., drought), regional hydrologic conditions, and the upstream land use.

ACTIVITIES

The most common maintenance activity is the removal of leaves from the system and bypass structure. Visual inspections are routine for system maintenance. This includes looking for standing water, accumulated leaves, holes in the soil media, signs of plant distress, and debris and sediment accumulation in the system. Mulch and/or vegetation coverage is integral to the performance of the system, including infiltration rate and nutrient uptake. Vegetation care is important to system productivity and health.

ACTIVITY	FREQUENCY
A record should be kept of the time to drain for the system completely after a storm event. The system should drain completely within 72 hours.	After every major storm in the first few months, then biannually.
Check to insure the filter surface remains well draining after storm event. Remedy: If filter bed is clogged, draining poorly, or standing water covers more than 15% of the surface 48 hours after a precipitation event, then remove top few inches of discolored material. Till or rake remaining material as needed.	
Check inlets and outlets for leaves and debris. Remedy: Rake in and around the system to clear it of debris. Also, clear the inlet and overflow if obstructed.	Quarterly initially, biannually, frequency adjusted as needed after 3 inspections
Check for animal burrows and short circuiting in the system Remedy: Soil erosion from short circuiting or animal borroughs should be repaired when they occur. The holes should be filled and lightly compacted.	
Check to insure the filter bed does not contain more than 2 inches accumulated material Remedy: Remove sediment as necessary. If 2 inches or more of filter bed has been removed, replace media with either mulch or a (50% sand, 20% woodchips, 20% compost, 10% soil) mixture.	
During extended periods without rainfall, inspect plants for signs of distress. Remedy: Plants should be watered until established (typical only for first few months) or as needed thereafter.	
Inspect inlets and outlets to ensure good condition and no evidence of deterioration. Check to see if high-flow bypass is functioning. Remedy: Repair or replace any damaged structural parts, inlets, outlets, sidewalls.	Annually
Check for robust vegetation coverage throughout the system. Remedy: If at least 50% vegetation coverage is not established after 2 years, reinforcement planting should be performed.	
Check for dead or dying plants, and general long term plant health. Remedy: This vegetation should be cut and removed from the system. If woody vegetation is present, care should be taken to remove dead or decaying plant Material. Separation of Herbaceous vegetation rootstock should occur when overcrowding is observed.	As needed

CHECKLIST FOR INSPECTION OF BIORETENTION SYSTEM / TREE FILTERS

Location:

Inspector:

Date:

Time:

Site Conditions:

Date Since Last Rain Event:

Inspection Items	Satisfactory (S) or Unsatisfactory (U)		Comments/Corrective Action
1. Initial Inspection After Planting and Mulching			
Plants are stable, roots not exposed	S	U	
Surface is at design level, typically 4" below overpass	S	U	
Overflow bypass / inlet (if available) is functional	S	U	
2. Debris Cleanup (2 times a year minimum, Spring & Fall)			
Litter, leaves, and dead vegetation removed from the system	S	U	
Prune perennial vegetation	S	U	
3. Standing Water (1 time a year, After large storm events)			
No evidence of standing water after 72 hours	S	U	
4. Short Circuiting & Erosion (1 time a year, After large storm events)			
No evidence of animal burrows or other holes	S	U	
No evidence of erosion	S	U	
5. Drought Conditions (As needed)			
Water plants as needed	S	U	
Dead or dying plants			
6. Overflow Bypass / Inlet Inspection (1 time a year, After large storm events)			
No evidence of blockage or accumulated leaves	S	U	
Good condition, no need for repair	S	U	
7. Vegetation Coverage (once a year)			
50% coverage established throughout system by first year	S	U	
Robust coverage by year 2 or later	S	U	
8. Mulch Depth (if applicable)(once every 2 years)			
Mulch at original design depth after tilling or replacement	S	U	
9. Vegetation Health (once every 3 years)			
Dead or decaying plants removed from the system	S	U	
10. Tree Pruning (once every 3 years)			
Prune dead, diseased, or crossing branches	S	U	
Corrective Action Needed			Due Date
1.			
2.			
3.			

APPENDIX XI

Pre- and Post-Construction Watershed Plans

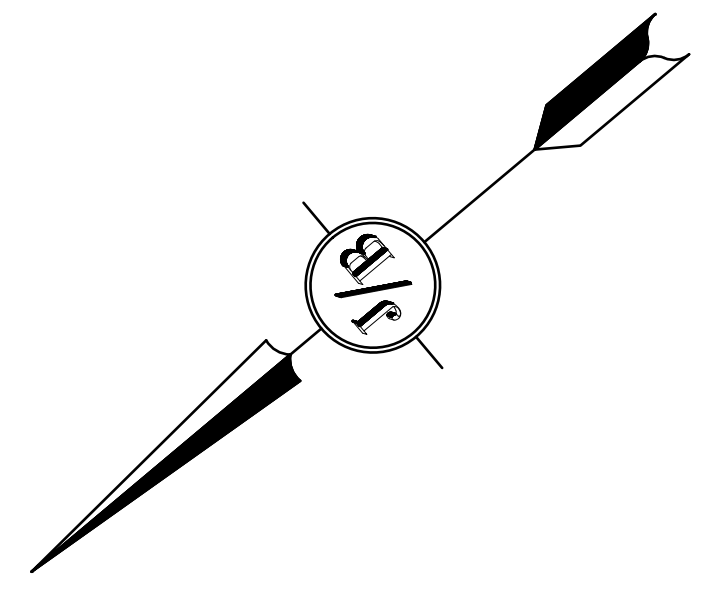

- LEGEND**
- SUBCATCHMENT BOUNDARY
 - SUBCATCHMENT
 - REACH
 - POND
 - TC PATH
 - SSSM SOILS
 - FLOW ARROW

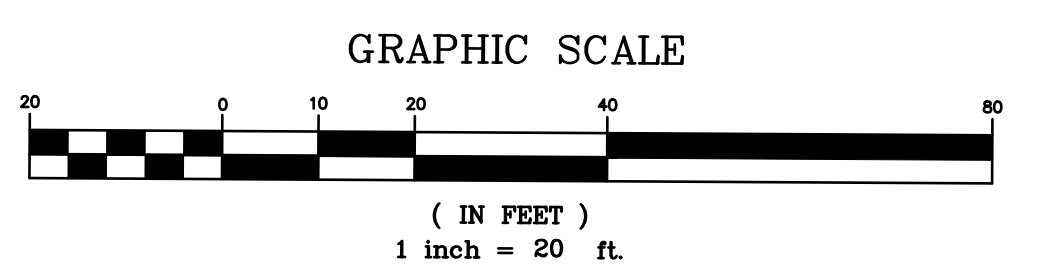

OFFSITE TOPOGRAPHY FROM NH GRANIT LIDAR. TOPOGRAPHIC FIELD SURVEY HAS NOT BEEN PERFORMED ON TIDEWATCH CONDOMINIUM PROPERTY.

PROJECT PARCEL
CITY OF PORTSMOUTH
TAX MAP 222, LOT 19

TOTAL LOT AREA
84,795 SQ. FT.
1.95 ACRES

Design: DJM Draft: DJM Date: 2/26/2024
 Checked: PSL Scale: AS NOTED Project No.: 18134.1
 Drawing Name: 18134-WATERSHED.dwg
 THIS PLAN SHALL NOT BE MODIFIED WITHOUT WRITTEN PERMISSION FROM JONES & BEACH ENGINEERS, INC. (JBE). ANY ALTERATIONS, AUTHORIZED OR OTHERWISE, SHALL BE AT THE USER'S SOLE RISK AND WITHOUT LIABILITY TO JBE.

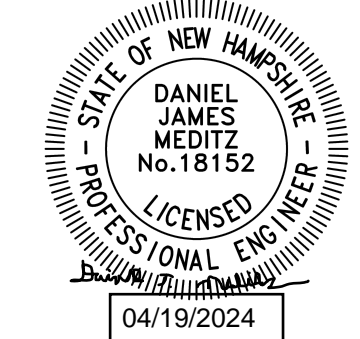

REV.	DATE	REVISION	BY
1	4/19/24	REVISED PER TAC COMMENTS	DJM
0	3/8/24	ISSUED FOR REVIEW	DJM

Designed and Produced in NH

J/B Jones & Beach Engineers, Inc.
Civil Engineering Services

85 Portsmouth Ave. PO Box 219 Stratham, NH 03885 603-772-4746 E-MAIL: JBE@JONESANDBEACH.COM

Plan Name: **EXISTING WATERSHED PLAN**

Project: **"LUSTER CLUSTER" 635 SAGAMORE AVE., PORTSMOUTH, NH**

Owner of Record: 635 SAGAMORE DEVELOPMENT LLC
 3612 LAFAYETTE RD., DEPT 4, PORTSMOUTH, NH 03801 BK 6332 PG 1158

DRAWING No. **W1**

SHEET 1 OF 2
 JBE PROJECT NO. 18134.1



- LEGEND**
- SUBCATCHMENT BOUNDARY
 - SUBCATCHMENT
 - REACH
 - POND
 - TC PATH
 - SSSM SOILS
 - FLOW ARROW

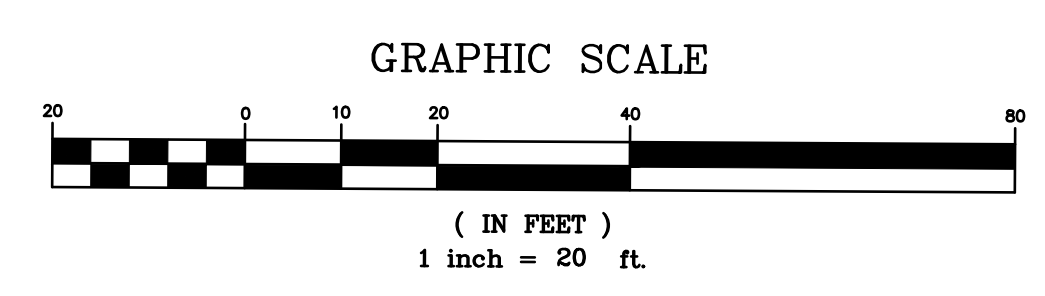

PROJECT PARCEL
CITY OF PORTSMOUTH
TAX MAP 222, LOT 19

TOTAL LOT AREA
84,795 SQ. FT.
1.95 ACRES

Design: DJM Draft: DJM Date: 2/26/2024
 Checked: PSL Scale: AS NOTED Project No.: 18134.1
 Drawing Name: 18134-WATERSHED.dwg

THIS PLAN SHALL NOT BE MODIFIED WITHOUT WRITTEN PERMISSION FROM JONES & BEACH ENGINEERS, INC. (JBE). ANY ALTERATIONS, AUTHORIZED OR OTHERWISE, SHALL BE AT THE USER'S SOLE RISK AND WITHOUT LIABILITY TO JBE.

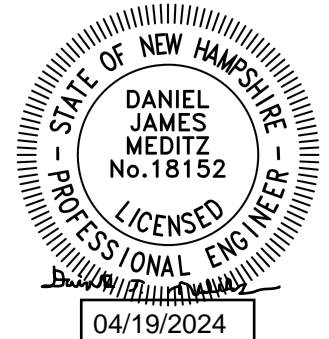

REV.	DATE	REVISION	BY
1	4/19/24	REVISED PER TAC COMMENTS	DJM
0	3/8/24	ISSUED FOR REVIEW	DJM

Designed and Produced in NH

J/B Jones & Beach Engineers, Inc.

85 Portsmouth Ave. Civil Engineering Services 603-772-4746
 PO Box 219
 Stratham, NH 03885 E-MAIL: JBE@JONESANDBEACH.COM

Plan Name: **PROPOSED WATERSHED PLAN**

Project: **"LUSTER CLUSTER"**
635 SAGAMORE AVE., PORTSMOUTH, NH

Owner of Record: 3612 LAFAYETTE RD., DEPT 4, PORTSMOUTH, NH 03801 BK 6332 PG 1158

DRAWING No.

W2

SHEET 2 OF 2
 JBE PROJECT NO. 18134.1



Know what's below
811 before you dig

SINGLE FAMILY CONDOMINIUM "LUSTER CLUSTER" TAX MAP 222, LOT 19 635 SAGAMORE AVE., PORTSMOUTH, NH

GENERAL LEGEND

EXISTING	PROPOSED	DESCRIPTION
---	---	PROPERTY LINES
---	---	SETBACK LINES
---	---	CENTERLINE
---	---	TREE LINE
---	---	STONEWALL
---	---	BARBED WIRE
---	---	FENCE
---	---	SOIL BOUNDARY
---	---	EASEMENT
---	---	MAJOR CONTOUR
---	---	MINOR CONTOUR
---	---	EDGE OF PAVEMENT
---	---	VERTICAL GRANITE CURB
---	---	SLOPE GRANITE CURB
---	---	FIBER BERM
---	---	DRAINAGE LINE
---	---	SEWER LINE
---	---	SEWER FORCE MAIN
---	---	GAS LINE
---	---	WATER LINE
---	---	WATER SERVICE
---	---	OVERHEAD ELECTRIC
---	---	UNDERGROUND ELECTRIC
---	---	UNDERDRAIN
---	---	THRUST BLOCK
---	---	IRON PIPE/IRON ROD
---	---	DRILL HOLE
---	---	IRON ROD/DRILL HOLE
---	---	STONE/GRANITE BOUND
---	---	SPOT GRADE
---	---	PAVEMENT SPOT GRADE
---	---	CURB SPOT GRADE
---	---	BENCHMARK (TBM)
---	---	DOUBLE POST SIGN
---	---	SINGLE POST SIGN
---	---	WELL
---	---	TEST PIT
---	---	TREES AND BUSHES
---	---	UTILITY POLE
---	---	DRAIN MANHOLE
---	---	SEWER MANHOLE
---	---	HYDRANT
---	---	WATER GATE VALVE
---	---	WATER SHUT OFF
---	---	REDUCER
---	---	SINGLE GRATE CATCH BASIN
---	---	TRANSFORMER
---	---	CULVERT W/FLARED END SECTION
---	---	CULVERT W/STRAIGHT HEADWALL
---	---	STONE CHECK DAM
---	---	DRAINAGE FLOW DIRECTION
---	---	RIPRAP
---	---	PAVEMENT HATCH
---	---	STABILIZED CONSTRUCTION
---	---	ENTRANCE
---	---	CONCRETE
---	---	GRAVEL
---	---	SNOW STORAGE
---	---	RETAINING WALL

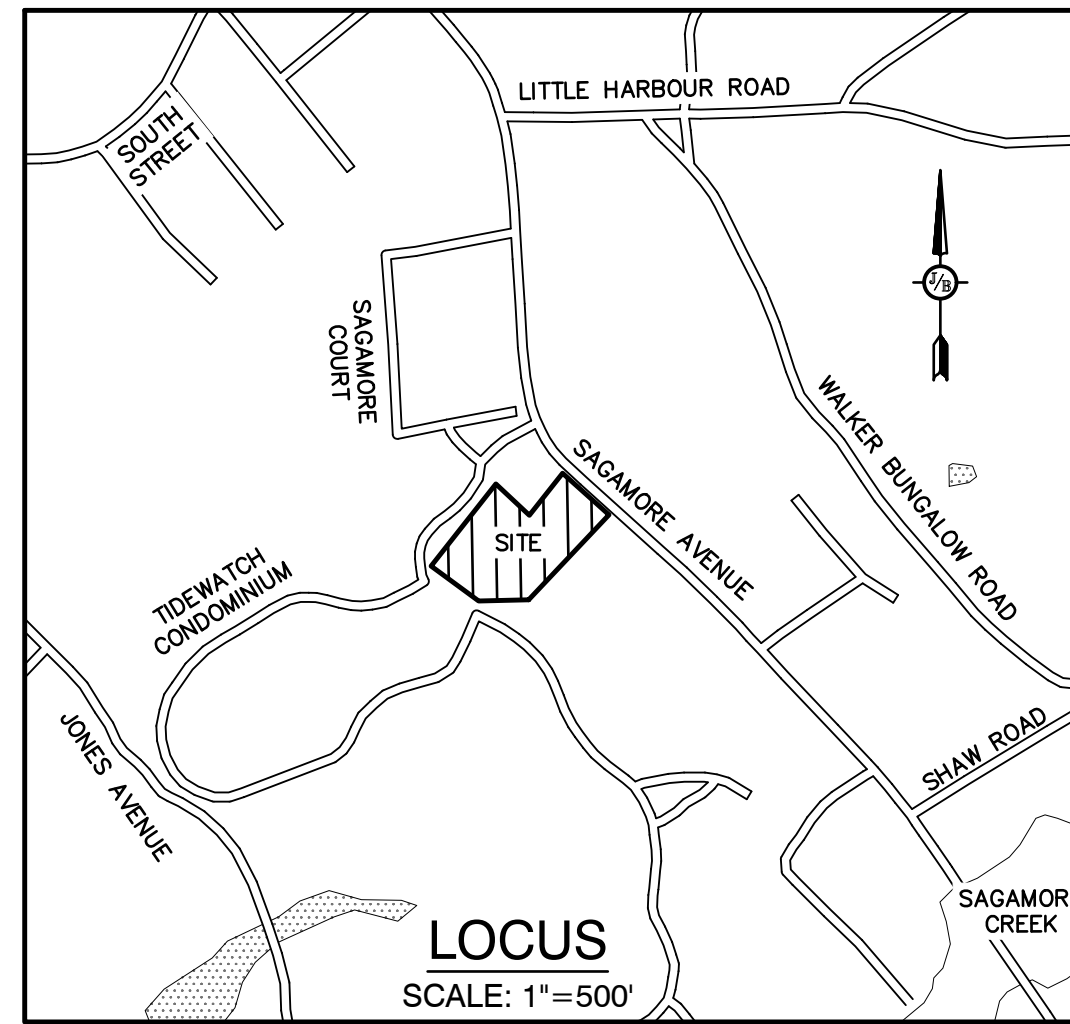

SHEET INDEX

CS	COVER SHEET
C1	EXISTING CONDITIONS PLAN
DM1	DEMOLITION PLAN
C2	SITE PLAN
CS1	CONDOMINIUM SITE PLAN
C3	GRADING AND DRAINAGE PLAN
C4	UTILITY PLAN
L1	LIGHTING PLAN
L2	LANDSCAPE PLAN
P1	DRIVEWAY PLAN AND PROFILE
P2	SEWER PLAN AND PROFILE
H1	HIGHWAY ACCESS PLAN
T1-T2	TRUCK TURNING PLAN
D1-D5	DETAIL SHEET
E1	EROSION AND SEDIMENT CONTROL DETAILS
	ARCHITECTURAL PLANS

CIVIL ENGINEER / SURVEYOR
JONES & BEACH ENGINEERS, INC.
 85 PORTSMOUTH AVENUE
 PO BOX 219
 STRATHAM, NH 03885
 (603) 772-4746
 CONTACT: JOSEPH CORONATI
 EMAIL: JCORONATI@JONESANDBEACH.COM

TRAFFIC ENGINEER
STEPHEN G. PERNAW & COMPANY, INC.
 P.O. BOX 1721
 CONCORD, NH 03302
 (603) 731-8500
 CONTACT: STEPHEN PERNAW

SOILS CONSULTANT
GOVE ENVIRONMENTAL SERVICES, INC.
 8 CONTINENTAL DRIVE, BLDG 2, UNIT H
 EXETER, NH 03833-7507
 (603) 418-7260
 CONTACT: JAMES GOVE
 EMAIL: JGOVE@GESINC.BIZ

LANDSCAPE DESIGNER
LM LAND DESIGN, LLC
 11 SOUTH ROAD
 BRENTWOOD, NH 03833
 (603) 770-7728
 CONTACT: LISE MCNAUGHTON

WATER
 CITY OF PORTSMOUTH
 DEPARTMENT OF PUBLIC WORKS
 WATER DIVISION
 680 PEVERLY HILL ROAD
 PORTSMOUTH, NH 03801
 (603) 427-1530

SEWER
 CITY OF PORTSMOUTH
 DEPARTMENT OF PUBLIC WORKS
 SEWER DIVISION
 680 PEVERLY HILL ROAD
 PORTSMOUTH, NH 03801
 (603) 766-1421

LIGHTING DESIGN
 EXPOSURE LIGHTING
 501 ISLINGTON STREET, UNIT 1A
 PORTSMOUTH, NH 03801
 CONTACT: KEN SWEENEY

ELECTRIC
EVERSOURCE
 1700 LAFAYETTE ROAD
 PORTSMOUTH, NH 03801
 (800) 662-7764

TELEPHONE
 CONSOLIDATED COMMUNICATIONS
 1575 GREENLAND ROAD
 GREENLAND, NH 03840
 (800) 427-5525

CABLE TV
 COMCAST COMMUNICATION CORPORATION
 334-B CALEF HIGHWAY
 EPPING, NH 03042-2325
 (603) 679-5695

PROJECT PARCEL
 CITY OF PORTSMOUTH
 TAX MAP 222, LOT 19

TOTAL LOT AREA
 84,795 SQ. FT.
 1.95 ACRES

CITY OF PORTSMOUTH PLANNING BOARD
 CHAIRPERSON _____ DATE _____

Design: DJM	Draft: KDR	Date: 2/26/2024
Checked: JAC	Scale: AS NOTED	Project No.: 18134.1
Drawing Name: 18134.1-PLAN.dwg		
THIS PLAN SHALL NOT BE MODIFIED WITHOUT WRITTEN PERMISSION FROM JONES & BEACH ENGINEERS, INC. (JBE). ANY ALTERATIONS, AUTHORIZED OR OTHERWISE, SHALL BE AT THE USER'S SOLE RISK AND WITHOUT LIABILITY TO JBE.		

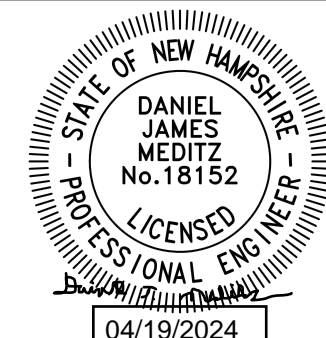

REV.	DATE	REVISION	BY
1	4/19/24	REVISED PER TAC COMMENTS	DJM
0	3/18/24	ISSUED FOR REVIEW	KDR

Designed and Produced in NH

J/B Jones & Beach Engineers, Inc.
 85 Portsmouth Ave. Civil Engineering Services 603-772-4746
 PO Box 219 Stratham, NH 03885 E-MAIL: JBE@JONESANDBEACH.COM

Plan Name:	COVER SHEET
Project:	LUSTER CLUSTER 635 SAGAMORE AVE., PORTSMOUTH, NH
Owner of Record:	3612 LAFAYETTE RD., DEPT 4, PORTSMOUTH, NH 03801 BK 6332 PG 1158

DRAWING No.	CS
SHEET 1 OF 20	
JBE PROJECT NO. 18134.1	

635 SAGAMORE AVE. PORTSMOUTH, NH
JBE # 18134.1 REVISION 1 - 4/19/24

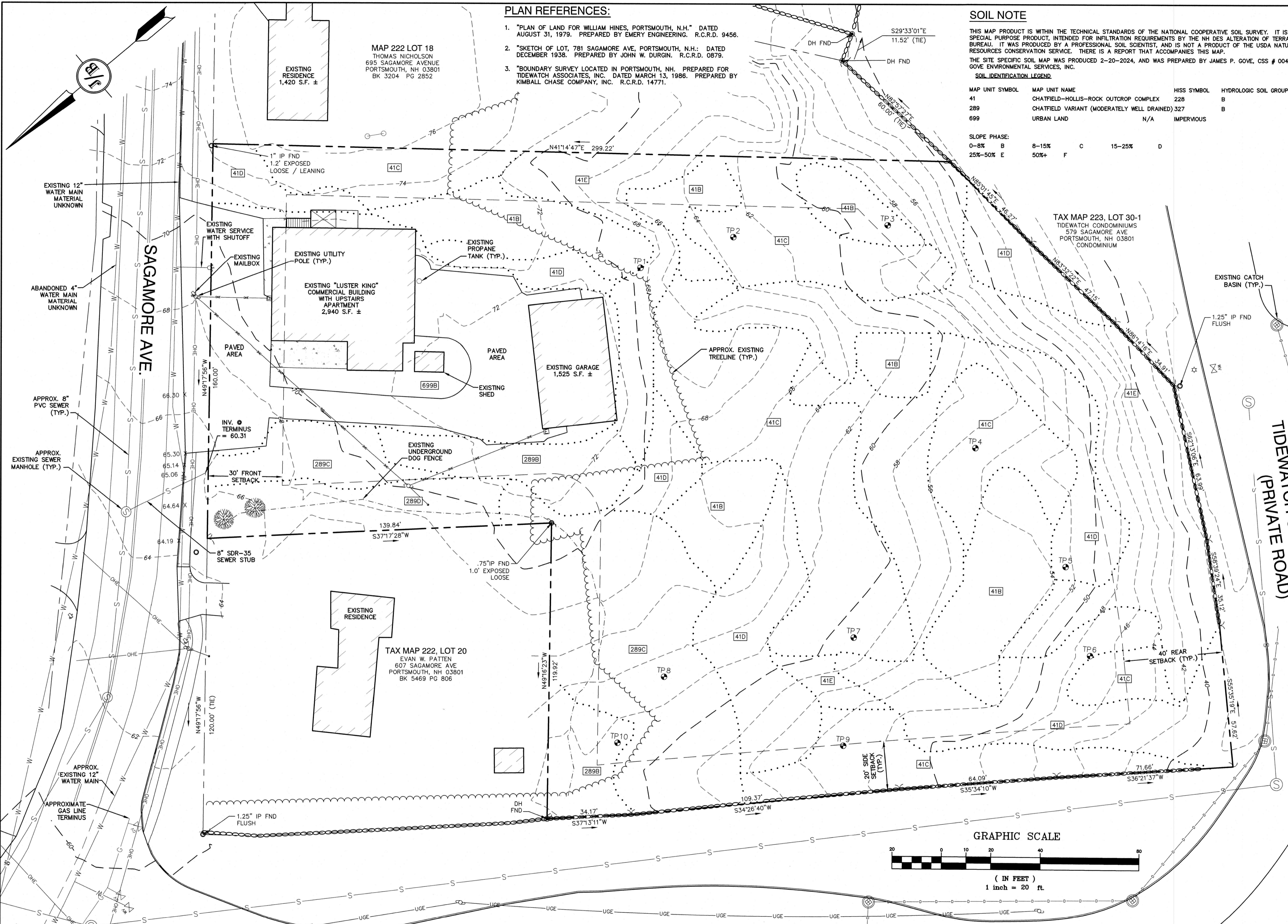

PLAN REFERENCES:

1. "PLAN OF LAND FOR WILLIAM HINES, PORTSMOUTH, N.H." DATED AUGUST 31, 1979. PREPARED BY EMERY ENGINEERING. R.C.R.D. 9456.
2. "SKETCH OF LOT, 781 SAGAMORE AVE, PORTSMOUTH, N.H." DATED DECEMBER 1938. PREPARED BY JOHN W. DURGIN. R.C.R.D. 0879.
3. "BOUNDARY SURVEY LOCATED IN PORTSMOUTH, NH. PREPARED FOR TIDEWATCH ASSOCIATES, INC. DATED MARCH 13, 1986. PREPARED BY KIMBALL CHASE COMPANY, INC. R.C.R.D. 14771.

SOIL NOTE

THIS MAP PRODUCT IS WITHIN THE TECHNICAL STANDARDS OF THE NATIONAL COOPERATIVE SOIL SURVEY. IT IS A SPECIAL PURPOSE PRODUCT, INTENDED FOR INFILTRATION REQUIREMENTS BY THE NH DES ALTERATION OF TERRAIN BUREAU. IT WAS PRODUCED BY A PROFESSIONAL SOIL SCIENTIST, AND IS NOT A PRODUCT OF THE USDA NATURAL RESOURCES CONSERVATION SERVICE. THERE IS A REPORT THAT ACCOMPANIES THIS MAP.

THE SITE SPECIFIC SOIL MAP WAS PRODUCED 2-20-2024, AND WAS PREPARED BY JAMES P. GOVE, CSS # 004, GOVE ENVIRONMENTAL SERVICES, INC.

SOIL IDENTIFICATION LEGEND:

MAP UNIT SYMBOL	MAP UNIT NAME	HISS SYMBOL	HYDROLOGIC SOIL GROUP
41	CHATFIELD-HOLLIS-ROCK OUTCROP COMPLEX	228	B
289	CHATFIELD VARIANT (MODERATELY WELL DRAINED)	327	B
699	URBAN LAND	N/A	IMPERVIOUS

SLOPE PHASE:

SLOPE PHASE	PERCENT	LETTER
0-8%	B	
8-15%	C	
15-25%	D	
25%-50%	E	
50%+	F	

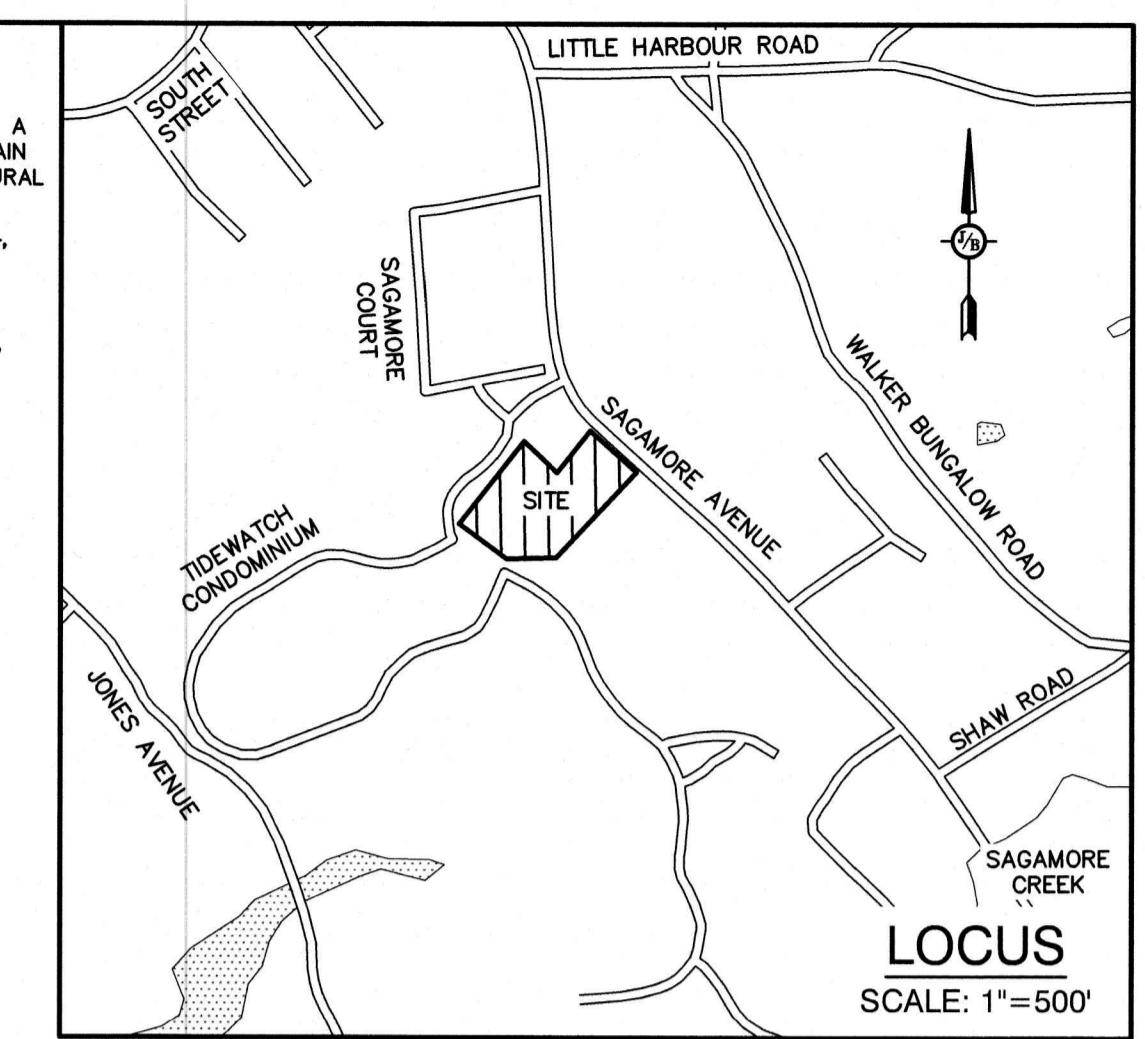

MAP 222 LOT 18
THOMAS NICHOLSON
695 SAGAMORE AVENUE
PORTSMOUTH, NH 03801
BK 3204 PG 2852

TAX MAP 223, LOT 30-1
TIDEWATCH CONDOMINIUMS
579 SAGAMORE AVE
PORTSMOUTH, NH 03801
CONDOMINIUM

TAX MAP 222, LOT 20
EVAN W. PATTEN
607 SAGAMORE AVE
PORTSMOUTH, NH 03801
BK 5469 PG 806

ABUTTERS ACROSS 635 SAGAMORE AVE.:

TAX MAP 222, LOT 14
JOHN O'SULLIVAN
DENISE BROWN
692 SAGAMORE AVE
PORTSMOUTH, NH 03801
BK 2350 PG 181

TAX MAP 222, LOT 14-1
BROWN FAMILY REV. TRUST
VINCENT A. & LINDA M. BROWN, TRUSTEES
DENISE BROWN
650 SAGAMORE AVE
PORTSMOUTH, NH 03801
BK 6074 PG 238

EXISTING CONDITIONS NOTES:

1. UNDERGROUND FACILITIES, UTILITIES AND STRUCTURES HAVE BEEN PLOTTED FROM FIELD OBSERVATION AND THEIR LOCATION MUST BE CONSIDERED APPROXIMATE ONLY. NEITHER JONES & BEACH ENGINEERS, INC., NOR ANY OF THEIR EMPLOYEES TAKE RESPONSIBILITY FOR THE LOCATION OF ANY UNDERGROUND STRUCTURES OR UTILITIES NOT SHOWN THAT MAY EXIST. IT IS THE RESPONSIBILITY OF THE CONTRACTOR TO HAVE ALL UNDERGROUND STRUCTURES AND/OR UTILITIES LOCATED PRIOR TO EXCAVATION WORK BY CALLING 1-888-DIG-SAFE (1-888-344-7233).
2. THE INTENT OF THIS PLAN IS TO SHOW THE EXISTING FEATURES LOCATED ON CITY OF PORTSMOUTH TAX MAP 222, LOT 19.
3. VERTICAL DATUM: NAVD88. HORIZONTAL DATUM: NH STATE PLANE
4. SUBJECT PROPERTY IS NOT LOCATED WITHIN FEDERALLY DESIGNATED 100 YEAR FLOOD HAZARD ZONE. REFERENCE FEMA COMMUNITY PANEL NO. 33015C0270F, DATED JANUARY 29, 2021.
5. NO WETLANDS WERE OBSERVED WITHIN 100' OF THE PROPERTY BOUNDARY. SEE LETTER FROM GOVE ENVIRONMENTAL SERVICES, INC.
6. SURVEY LINES SHOWN HEREIN ARE NOT BOUNDARY LINES. THEY SHOULD ONLY BE USED TO LOCATE THE PARCEL SURVEYED FROM THE FOUND MONUMENTS SHOWN AND LOCATED BY THIS SURVEY.

CERTIFICATION:

PURSUANT TO RSA 676:18-III AND RSA 672:14

I CERTIFY THAT THIS SURVEY PLAN IS NOT A SUBDIVISION PURSUANT TO THIS TITLE AND THAT THE LINES OF STREETS AND WAYS SHOWN ARE THOSE OF PUBLIC OR PRIVATE STREETS OR WAYS ALREADY ESTABLISHED AND THAT NO NEW WAYS ARE SHOWN.

I CERTIFY THAT THIS PLAN WAS PREPARED UNDER MY DIRECT SUPERVISION, THAT IT IS THE RESULT OF A FIELD SURVEY BY THIS OFFICE AND HAS AN UNADJUSTED LINEAR ERROR OF CLOSURE THAT EXCEEDS BOTH THE MINIMUM OF 1:10,000 AS DEFINED IN SECTION 503.04 OF THE NEW HAMPSHIRE CODE OF ADMINISTRATIVE RULES AND THE MINIMUM OF 1:15,000 AS DEFINED IN SECTION 4.2 OF THE N.H.L.S.A. ETHICS AND STANDARDS.

THIS SURVEY CONFORMS TO A CATEGORY 1 CONDITION 1 SURVEY AS DEFINED IN SECTION 4.1 OF THE N.H.L.S.A. ETHICS AND STANDARDS.

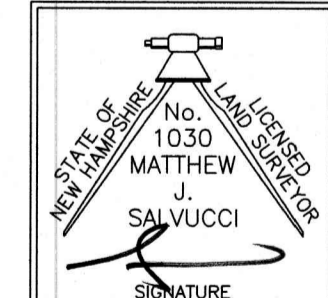

MATTHEW J. SALVUCCI, LLS 1030
ON BEHALF OF JONES & BEACH ENGINEERS, INC.

4/22/24
DATE:

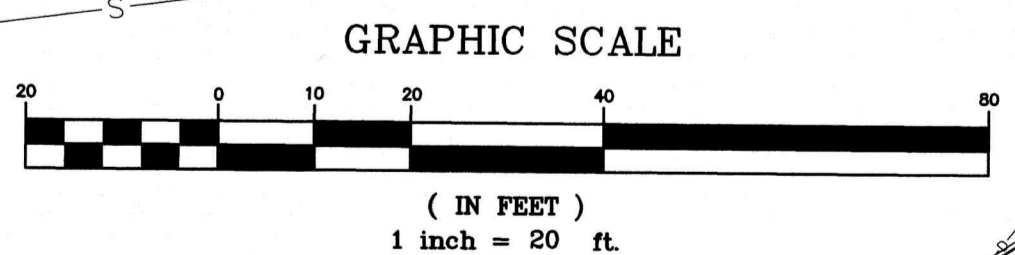

Design: DJM	Draft: KDR	Date: 2/26/2024
Checked: JAC	Scale: AS NOTED	Project No.: 18134.1
Drawing Name: 18134.1-PLAN.dwg		
THIS PLAN SHALL NOT BE MODIFIED WITHOUT WRITTEN PERMISSION FROM JONES & BEACH ENGINEERS, INC. (JBE). ANY ALTERATIONS, AUTHORIZED OR OTHERWISE, SHALL BE AT THE USER'S SOLE RISK AND WITHOUT LIABILITY TO JBE.		

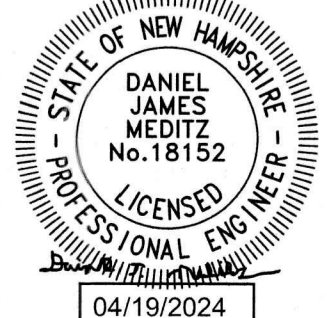

REV.	DATE	REVISION	BY
1	4/19/24	REVISED PER TAC COMMENTS	DJM
0	3/18/24	ISSUED FOR REVIEW	KDR

Designed and Produced in NH

J/B Jones & Beach Engineers, Inc.
Civil Engineering Services

85 Portsmouth Ave. PO Box 219 Stratham, NH 03885

603-772-4746
FAX: 603-772-0227
E-MAIL: JBE@JONESANDBEACH.COM

Plan Name:	EXISTING CONDITIONS PLAN
Project:	LUSTER CLUSTER 635 SAGAMORE AVE., PORTSMOUTH, NH
Owner of Record:	3612 LAFAYETTE RD., DEPT 4, PORTSMOUTH, NH 03801 BK 6332 PG 1158

DRAWING No.	C1
SHEET 2 OF 20	JBE PROJECT NO. 18134.1

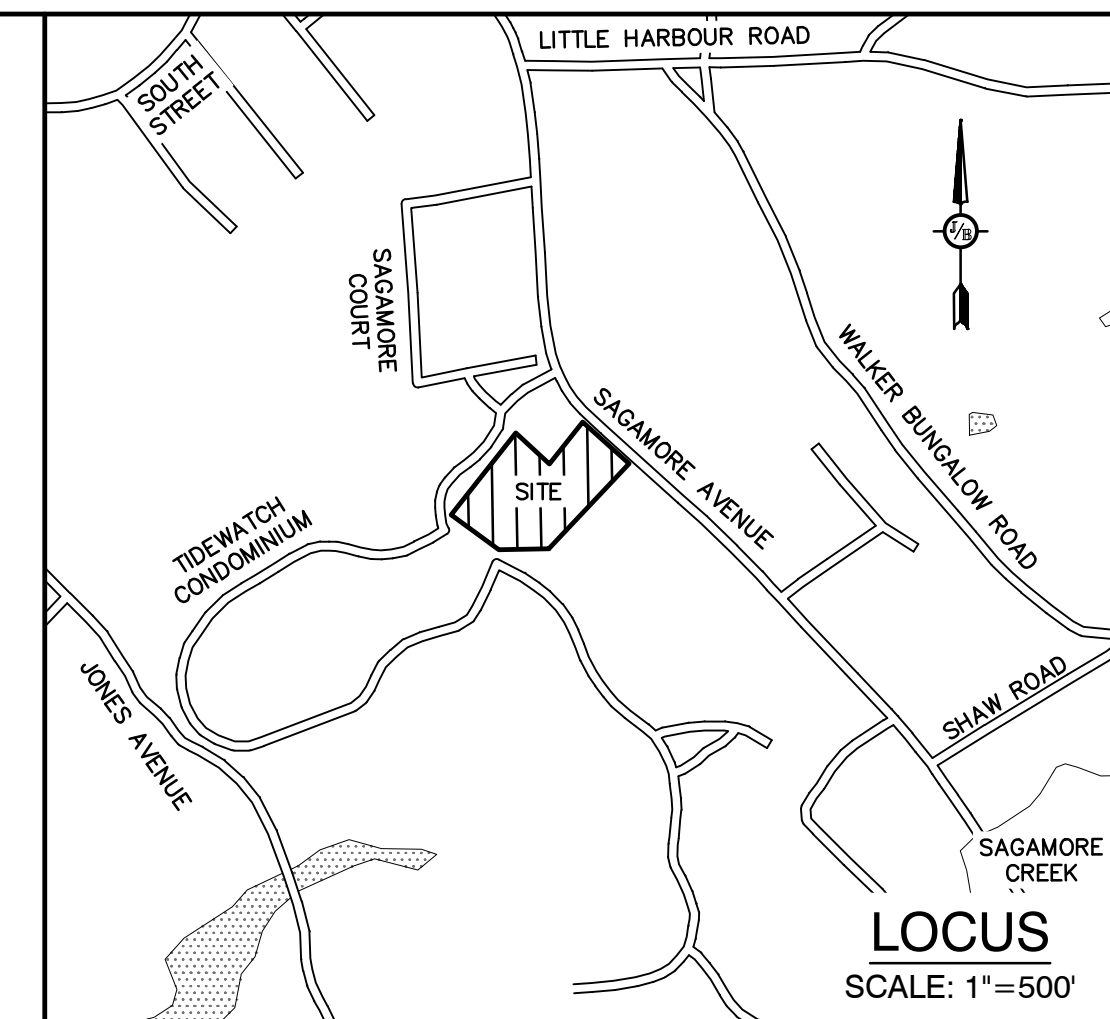
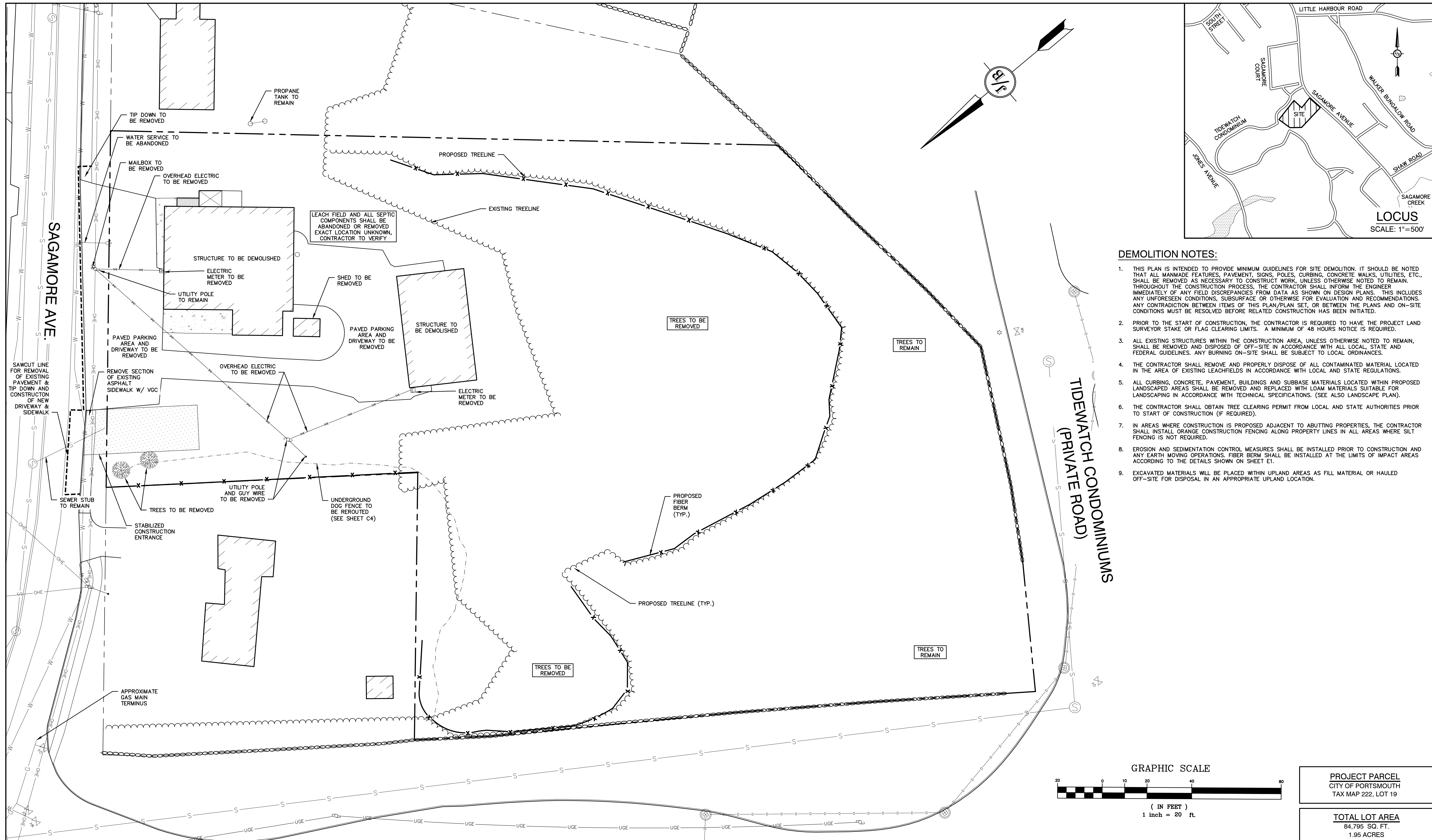

- DEMOLITION NOTES:**
1. THIS PLAN IS INTENDED TO PROVIDE MINIMUM GUIDELINES FOR SITE DEMOLITION. IT SHOULD BE NOTED THAT ALL MANMADE FEATURES, PAVEMENT, SIGNS, POLES, CURBING, CONCRETE WALKS, UTILITIES, ETC., SHALL BE REMOVED AS NECESSARY TO CONSTRUCT WORK, UNLESS OTHERWISE NOTED TO REMAIN. THROUGHOUT THE CONSTRUCTION PROCESS, THE CONTRACTOR SHALL INFORM THE ENGINEER IMMEDIATELY OF ANY FIELD DISCREPANCIES FROM DATA AS SHOWN ON DESIGN PLANS. THIS INCLUDES ANY UNFORESEEN CONDITIONS, SUBSURFACE OR OTHERWISE FOR EVALUATION AND RECOMMENDATIONS. ANY CONTRADICTION BETWEEN ITEMS OF THIS PLAN/PLAN SET, OR BETWEEN THE PLANS AND ON-SITE CONDITIONS MUST BE RESOLVED BEFORE RELATED CONSTRUCTION HAS BEEN INITIATED.
 2. PRIOR TO THE START OF CONSTRUCTION, THE CONTRACTOR IS REQUIRED TO HAVE THE PROJECT LAND SURVEYOR STAKE OR FLAG CLEARING LIMITS. A MINIMUM OF 48 HOURS NOTICE IS REQUIRED.
 3. ALL EXISTING STRUCTURES WITHIN THE CONSTRUCTION AREA, UNLESS OTHERWISE NOTED TO REMAIN, SHALL BE REMOVED AND DISPOSED OF OFF-SITE IN ACCORDANCE WITH ALL LOCAL, STATE AND FEDERAL GUIDELINES. ANY BURNING ON-SITE SHALL BE SUBJECT TO LOCAL ORDINANCES.
 4. THE CONTRACTOR SHALL REMOVE AND PROPERLY DISPOSE OF ALL CONTAMINATED MATERIAL LOCATED IN THE AREA OF EXISTING LEACHFIELDS IN ACCORDANCE WITH LOCAL AND STATE REGULATIONS.
 5. ALL CURBING, CONCRETE, PAVEMENT, BUILDINGS AND SUBBASE MATERIALS LOCATED WITHIN PROPOSED LANDSCAPED AREAS SHALL BE REMOVED AND REPLACED WITH LOAM MATERIALS SUITABLE FOR LANDSCAPING IN ACCORDANCE WITH TECHNICAL SPECIFICATIONS. (SEE ALSO LANDSCAPE PLAN).
 6. THE CONTRACTOR SHALL OBTAIN TREE CLEARING PERMIT FROM LOCAL AND STATE AUTHORITIES PRIOR TO START OF CONSTRUCTION (IF REQUIRED).
 7. IN AREAS WHERE CONSTRUCTION IS PROPOSED ADJACENT TO ABUTTING PROPERTIES, THE CONTRACTOR SHALL INSTALL ORANGE CONSTRUCTION FENCING ALONG PROPERTY LINES IN ALL AREAS WHERE SILT FENCING IS NOT REQUIRED.
 8. EROSION AND SEDIMENTATION CONTROL MEASURES SHALL BE INSTALLED PRIOR TO CONSTRUCTION AND ANY EARTH MOVING OPERATIONS. FIBER BERM SHALL BE INSTALLED AT THE LIMITS OF IMPACT AREAS ACCORDING TO THE DETAILS SHOWN ON SHEET E1.
 9. EXCAVATED MATERIALS WILL BE PLACED WITHIN UPLAND AREAS AS FILL MATERIAL OR HAULED OFF-SITE FOR DISPOSAL IN AN APPROPRIATE UPLAND LOCATION.

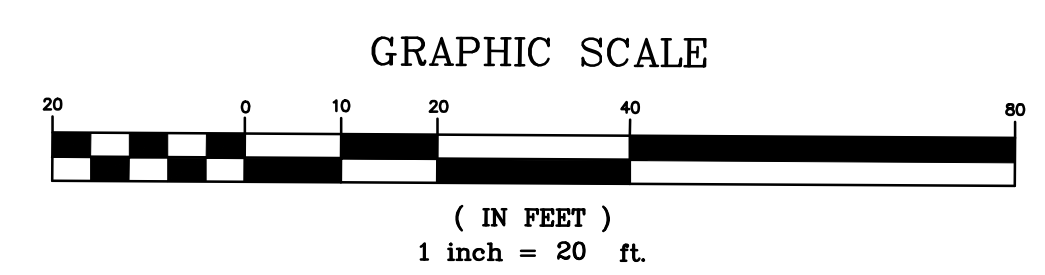

PROJECT PARCEL
CITY OF PORTSMOUTH
TAX MAP 222, LOT 19

TOTAL LOT AREA
84,795 SQ. FT.
1.95 ACRES

Design: DJM Draft: KDR Date: 2/26/2024
Checked: JAC Scale: AS NOTED Project No.: 18134.1
Drawing Name: 18134.1-PLAN.dwg

THIS PLAN SHALL NOT BE MODIFIED WITHOUT WRITTEN PERMISSION FROM JONES & BEACH ENGINEERS, INC. (JBE). ANY ALTERATIONS, AUTHORIZED OR OTHERWISE, SHALL BE AT THE USER'S SOLE RISK AND WITHOUT LIABILITY TO JBE.

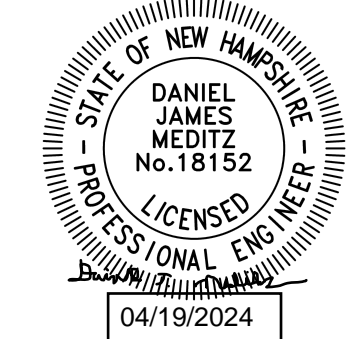

REV.	DATE	REVISION	BY
0	4/19/24	REVISED PER TAC COMMENTS	DJM
1	3/18/24	ISSUED FOR REVIEW	KDR

Designed and Produced in NH

J/B Jones & Beach Engineers, Inc.
Civil Engineering Services

85 Portsmouth Ave. PO Box 219 Stratham, NH 03885 603-772-4746 E-MAIL: JBE@JONESANDBEACH.COM

Plan Name: **DEMOLITION PLAN**

Project: **LUSTER CLUSTER
635 SAGAMORE AVE., PORTSMOUTH, NH**

Owner of Record: **3612 LAFAYETTE RD., DEPT 4, PORTSMOUTH, NH 03801 BK 6332 PG 1158**

DRAWING No.

DM-1

SHEET 3 OF 20
JBE PROJECT NO. 18134.1

ABUTTERS ACROSS SAGAMORE AVE.:

TAX MAP 222, LOT 14
 JOHN O'SULLIVAN
 DENISE BROWN
 692 SAGAMORE AVE
 PORTSMOUTH, NH 03801
 BK 3250 PG 181

TAX MAP 222, LOT 14-1
 BROWN FAMILY REV. TRUST
 VINCENT A. & LINDA M. BROWN, TRUSTEES
 DENISE BROWN
 650 SAGAMORE AVE
 PORTSMOUTH, NH 03801
 BK 6074 PG 238

MAP 222 LOT 18
 THOMAS NICHOLSON
 695 SAGAMORE AVENUE
 PORTSMOUTH, NH 03801
 BK 3204 PG 2852

PROPOSED 6' HIGH WOODEN FENCE BOTTOM OF PANELS SHALL BE AT LEAST 6" ABOVE FINISHED GRADE SEE SHEET D5

PLAN REFERENCES:

- "PLAN OF LAND FOR WILLIAM HINES, PORTSMOUTH, N.H." DATED AUGUST 31, 1979. PREPARED BY EMERY ENGINEERING. R.C.R.D. 9456.
- "SKETCH OF LOT, 781 SAGAMORE AVE, PORTSMOUTH, N.H.:" DATED DECEMBER 1938. PREPARED BY JOHN W. DURGIN. R.C.R.D. 0879.
- "BOUNDARY SURVEY LOCATED IN PORTSMOUTH, NH. PREPARED FOR TIDEWATCH ASSOCIATES, INC. DATED MARCH 13, 1986. PREPARED BY KIMBALL CHASE COMPANY, INC. R.C.R.D. 14771.

CERTIFICATION:

PURSUANT TO RSA 676:18-III AND RSA 672:14

I CERTIFY THAT THIS SURVEY PLAT IS NOT A SUBDIVISION PURSUANT TO THIS TITLE AND THAT THE LINES OF STREETS AND WAYS SHOWN ARE THOSE OF PUBLIC OR PRIVATE STREETS OR WAYS ALREADY ESTABLISHED AND THAT NO NEW WAYS ARE SHOWN.

I CERTIFY THAT THIS PLAT WAS PREPARED UNDER MY DIRECT SUPERVISION, THAT IT IS THE RESULT OF A FIELD SURVEY BY THIS OFFICE AND HAS AN UNADJUSTED LINEAR ERROR OF CLOSURE THAT EXCEEDS BOTH THE MINIMUM OF 1:10,000 AS DEFINED IN SECTION 503.04 OF THE NEW HAMPSHIRE CODE OF ADMINISTRATIVE RULES AND THE MINIMUM OF 1:15,000 AS DEFINED IN SECTION 4.2 OF THE N.H.L.S.A. ETHICS AND STANDARDS.

THIS SURVEY CONFORMS TO A CATEGORY 1 CONDITION 1 SURVEY AS DEFINED IN SECTION 4.1 OF THE N.H.L.S.A. ETHICS AND STANDARDS.

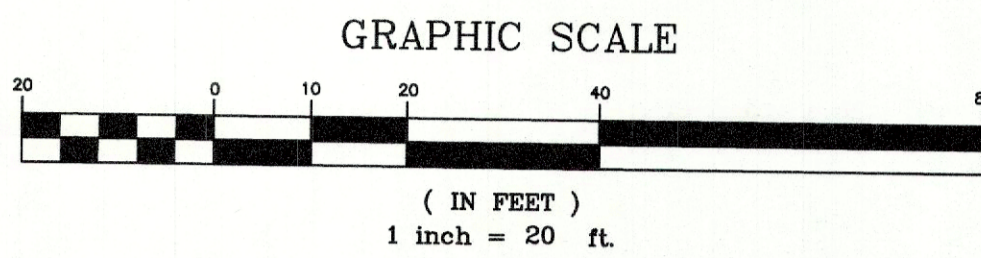

NEW STATE OF NEW HAMPSHIRE
 LAND REGISTERED FOR
 No. 1030
 MATTHEW J. SALVUCCI
 SIGNATURE

MATTHEW J. SALVUCCI, LLS 1030
 ON BEHALF OF JONES & BEACH ENGINEERS, INC.

4/22/24
DATE:

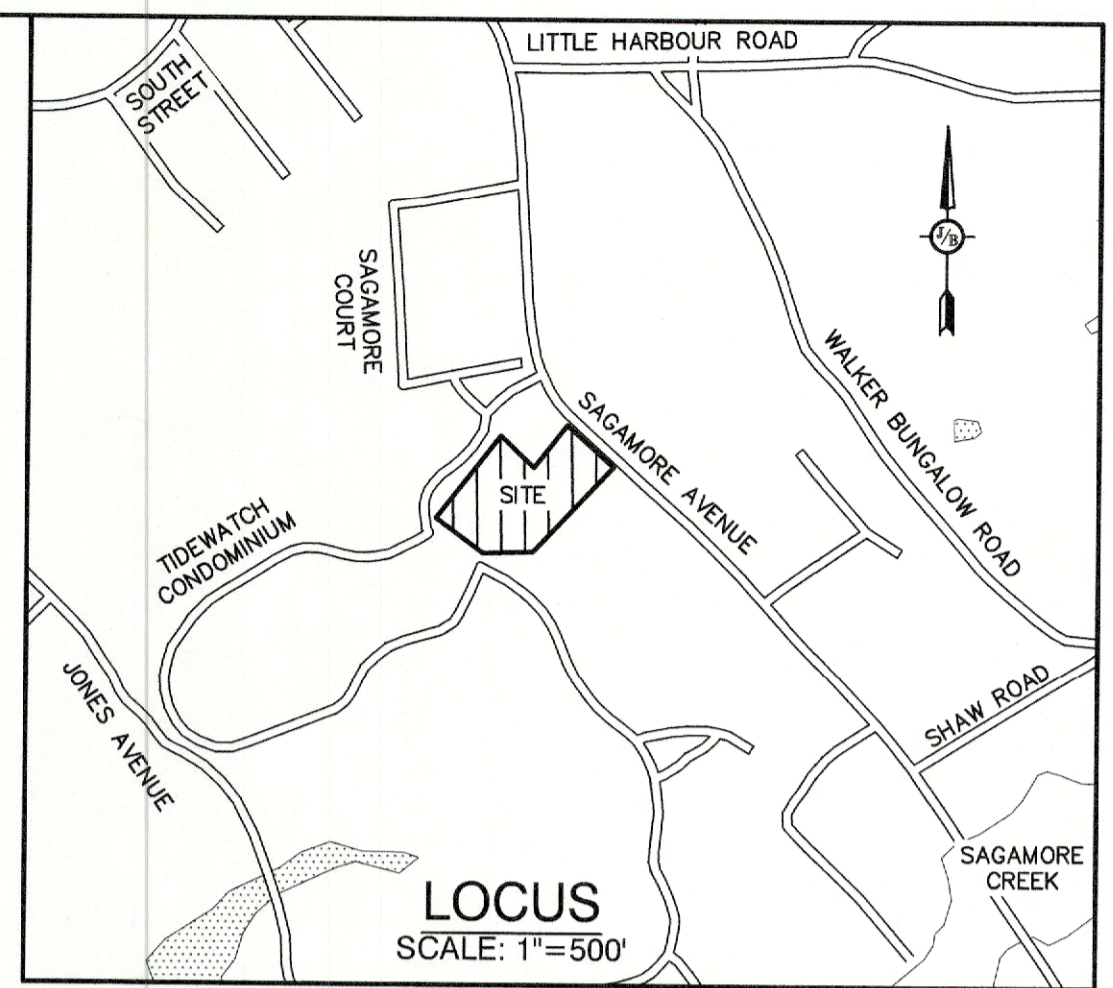

SITE NOTES:

- THE INTENT OF THIS PLAN IS TO REMOVE EXISTING STRUCTURES AND CONSTRUCT A 4-UNIT MULTI-FAMILY RESIDENTIAL DEVELOPMENT.
- ZONING DISTRICT: SINGLE RESIDENCE A (SRA)
 LOT AREA MINIMUM = 1 ACRE
 LOT FRONTAGE MINIMUM = 150'
 LOT DEPTH MINIMUM = 200'
 BUILDING SETBACKS (MINIMUM):
 FRONT SETBACK = 30'
 SIDE SETBACK = 20'
 REAR SETBACK = 40'
 WETLAND SETBACK = 100' FROM WETLANDS GREATER THAN 10,000 S.F.
 MAX. BUILDING HEIGHT = 35' FOR SLOPED ROOF; 30' FOR FLAT ROOF
 MAX. BUILDING COVERAGE = 10%
 BUILDING COVERAGE PROPOSED = 8,420 S.F. = 9.9%
 2 SPACES IN GARAGE + 2 SPACES IN DRIVEWAY PER UNIT = 4 SPACES PER UNIT * 4 UNITS
 DENSITY PROPOSED = 4 DWELLING UNITS / 1.947 AC. = 2.05 UNITS / ACRE
 (1 UNIT / 21,248 S.F.)
 MIN. OPEN SPACE = 50%
 OPEN SPACE PROPOSED = 68,700 S.F. = 80.0%
- PARKING CALCULATIONS:
 DWELLING UNIT FLOOR AREA OVER 750 S.F. - 1.3 SPACES REQUIRED PER UNIT
 1.3 * 4 DWELLING UNITS = 5.2 SPACES REQUIRED
 2 SPACES IN GARAGE + 2 SPACES IN DRIVEWAY PER UNIT = 4 SPACES PER UNIT * 4 UNITS
 16 SPACES PROVIDED
 ONE BICYCLE SPACE PROVIDED IN EACH GARAGE (1 REQUIRED FOR EVERY 5 DWELLING UNITS PER ZONING)
- ON MAY 23, 2023, THE PORTSMOUTH, NH ZONING BOARD OF ADJUSTMENT VOTED TO APPROVE VARIANCES FROM THE FOLLOWING SECTIONS OF THE ZONING ORDINANCE:
 A) SECTION 10.513 - TO PERMIT MORE THAN ONE FREE-STANDING DWELLING ON A LOT
 B) SECTION 10.521 - TO PERMIT LESS THAN ONE ACRE PER DWELLING UNIT
- NHDES SEWER CONNECTION PERMIT NO. , DATED
- NO WETLANDS WERE OBSERVED WITHIN 100' OF THE PROPERTY BOUNDARY. SEE LETTER FROM GOVE ENVIRONMENTAL SERVICES, INC.
- THIS PLAN SET HAS BEEN PREPARED BY JONES & BEACH ENGINEERS, INC., FOR MUNICIPAL AND STATE APPROVALS AND FOR CONSTRUCTION BASED ON DATA OBTAINED FROM ON-SITE FIELD SURVEY AND EXISTING MUNICIPAL RECORDS. THROUGHOUT THE CONSTRUCTION PROCESS, THE CONTRACTOR SHALL INFORM THE ENGINEER IMMEDIATELY OF ANY FIELD DISCREPANCY FROM DATA AS SHOWN ON THE DESIGN PLANS, INCLUDING ANY UNFORESEEN CONDITIONS, SUBSURFACE OR OTHERWISE, FOR EVALUATION AND RECOMMENDATIONS. ANY CONTRADICTION BETWEEN ITEMS ON THIS PLAN/PLAN SET, OR BETWEEN THE PLANS AND ON-SITE CONDITIONS, MUST BE RESOLVED BEFORE RELATED CONSTRUCTION HAS BEEN INITIATED. CONTRACTOR TO ALWAYS CONTACT DIG SAFE PRIOR TO DIGGING ON-SITE OR OFF-SITE TO ENSURE SAFETY AND OBEY THE LAW.
- ALL CONSTRUCTION SHALL CONFORM TO TOWN STANDARDS AND REGULATIONS, AND NHDOT STANDARD SPECIFICATIONS FOR ROAD AND BRIDGE CONSTRUCTION, WHICHEVER IS MORE STRINGENT.
- SUBJECT PROPERTY IS NOT LOCATED WITHIN FEDERALLY DESIGNATED 100 YEAR FLOOD HAZARD ZONE. REFERENCE FEMA COMMUNITY PANEL NO. 33015C0270F, DATED JANUARY 29, 2021.
- LANDOWNERS ARE RESPONSIBLE FOR COMPLYING WITH ALL APPLICABLE LOCAL, STATE AND FEDERAL WETLAND REGULATIONS, INCLUDING PERMITTING REQUIRED UNDER THESE REGULATIONS.
- ALL CONSTRUCTION ACTIVITIES SHALL BE PERFORMED IN ACCORDANCE WITH THE STORMWATER POLLUTION PREVENTION PLAN (S.W.P.P.P.). THIS DOCUMENT IS TO BE KEPT ON-SITE AT ALL TIMES AND UPDATED AS REQUIRED.
- PRIOR TO THE START OF CONSTRUCTION, THE CONTRACTOR SHALL COORDINATE WITH THE ENGINEER, ARCHITECT AND/OR OWNER, IN ORDER TO OBTAIN AND/OR PAY ALL THE NECESSARY LOCAL PERMITS, FEES AND BONDS.
- ALL SIGNAGE AND PAVEMENT MARKINGS SHALL BE IN ACCORDANCE WITH THE LATEST EDITION OF THE MANUAL ON UNIFORM TRAFFIC CONTROL DEVICES (M.U.T.C.D.) AND NHDOT STANDARDS AND SPECIFICATIONS (NON-REFLECTORIZED PAVEMENT MARKINGS), UNLESS OTHERWISE NOTED.
- ALL BUILDING DIMENSIONS SHALL BE VERIFIED WITH THE ARCHITECTURAL AND STRUCTURAL PLANS PROVIDED BY THE OWNER. ANY DISCREPANCIES SHOULD BE BROUGHT TO THE ATTENTION OF THE ENGINEER AND OWNER PRIOR TO THE START OF CONSTRUCTION. BUILDING DIMENSIONS AND AREAS TO BE TO OUTSIDE OF MASONRY, UNLESS OTHERWISE NOTED.
- SNOW TO BE STORED AT EDGE OF PAVEMENT AND IN AREAS SHOWN ON THE PLANS, OR TRUCKED OFFSITE TO AN APPROVED SNOW DUMPING LOCATION.
- ALL CONSTRUCTION ACTIVITIES SHALL CONFORM TO LABOR OCCUPATIONAL SAFETY AND HEALTH ADMINISTRATION (OSHA) RULES AND REGULATIONS.
- AN ACCESS EASEMENT SHALL BE GRANTED TO THE CITY OF PORTSMOUTH FOR ACCESS AND LEAK DETECTION OF THE WATER MAIN, SHUTOFFS, AND METERS ON THE PROPERTY. EASEMENT DESCRIPTION MUST BE APPROVED BY THE CITY'S LEGAL DEPARTMENT AND ACCEPTED BY THE CITY COUNCIL.
- ALL IMPROVEMENTS SHOWN ON THIS SITE PLAN SHALL BE CONSTRUCTED AND MAINTAINED IN ACCORDANCE WITH THE PLAN BY THE PROPERTY OWNER AND ALL FUTURE PROPERTY OWNERS. NO CHANGES SHALL BE MADE TO THE SITE PLAN WITHOUT THE EXPRESS APPROVAL OF THE PORTSMOUTH PLANNING DIRECTOR.
- THIS SITE PLAN SHALL BE RECORDED IN THE ROCKINGHAM COUNTY REGISTRY OF DEEDS.
- ALL CONDITIONS ON THIS PLAN SHALL REMAIN IN EFFECT IN PERPETUITY PURSUANT TO THE REQUIREMENTS OF THE SITE PLAN REVIEW REGULATIONS.
- THE OWNER OF EACH UNIT SHALL STORE TRASH IN THEIR GARAGE. TRASH WILL BE PICKED UP BY A PRIVATE HAULER.
- THE SUBJECT PARCEL IS NOT LOCATED WITHIN A WELLHEAD PROTECTION OR AQUIFER PROTECTION AREA PER NHDES ONESTOP DATA.
- SIDEWALK WORK IN SAGAMORE AVE. RIGHT OF WAY SHALL BE DONE BY THE CITY AND COORDINATED WITH THIS DEVELOPMENT.

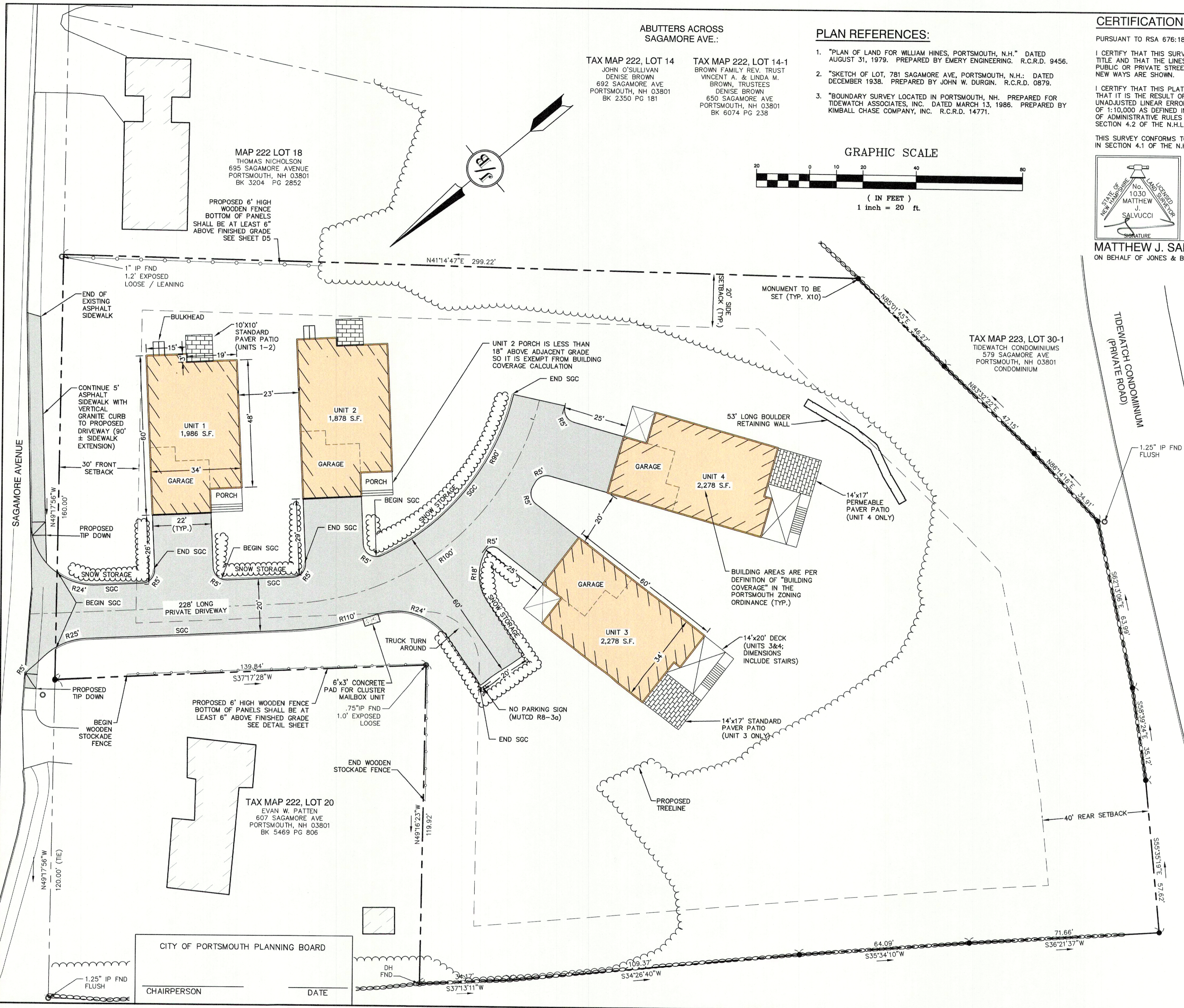

CITY OF PORTSMOUTH PLANNING BOARD

CHAIRPERSON _____ DATE _____

Design: DJM Draft: KDR Date: 2/26/2024
 Checked: JAC Scale: AS NOTED Project No.: 18134.1
 Drawing Name: 18134.1-PLAN.dwg

THIS PLAN SHALL NOT BE MODIFIED WITHOUT WRITTEN PERMISSION FROM JONES & BEACH ENGINEERS, INC. (JBE). ANY ALTERATIONS, AUTHORIZED OR OTHERWISE, SHALL BE AT THE USER'S SOLE RISK AND WITHOUT LIABILITY TO JBE.

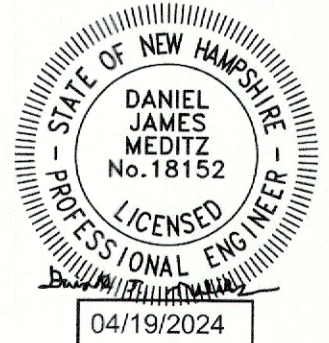

REV.	DATE	REVISION	BY
1	4/19/24	REVISED PER TAC COMMENTS	DJM
0	3/18/24	ISSUED FOR REVIEW	KDR

Designed and Produced in NH

J/B Jones & Beach Engineers, Inc.

85 Portsmouth Ave. Civil Engineering Services 603-772-4746
 PO Box 219 Stratham, NH 03885 FAX: 603-772-0227
 E-MAIL: JBE@JONESANDBEACH.COM

Plan Name: **SITE PLAN**

Project: **LUSTER CLUSTER
 635 SAGAMORE AVE., PORTSMOUTH, NH**

Owner of Record: **3612 LAFAYETTE RD., DEPT 4, PORTSMOUTH, NH 03801 BK 6332 PG 1158**

PROJECT PARCEL
 CITY OF PORTSMOUTH
 TAX MAP 222, LOT 19

TOTAL LOT AREA
 84,795 SQ. FT.
 1.95 ACRES

DRAWING No. **C2**

SHEET 4 OF 20
 JBE PROJECT NO. 18134.1

ABUTTERS ACROSS SAGAMORE AVE.:

TAX MAP 222, LOT 14
 JOHN O'SULLIVAN
 DENISE BROWN
 692 SAGAMORE AVE
 PORTSMOUTH, NH 03801
 BK 2350 PG 181

TAX MAP 222, LOT 14-1
 BROWN FAMILY REV. TRUST
 VINCENT A. & LINDA M. BROWN, TRUSTEES
 DENISE BROWN
 650 SAGAMORE AVE
 PORTSMOUTH, NH 03801
 BK 6074 PG 238

PLAN REFERENCES:

- "PLAN OF LAND FOR WILLIAM HINES, PORTSMOUTH, N.H." DATED AUGUST 31, 1979. PREPARED BY EMERY ENGINEERING. R.C.R.D. 9456.
- "SKETCH OF LOT, 781 SAGAMORE AVE, PORTSMOUTH, N.H.: DATED DECEMBER 1938. PREPARED BY JOHN W. DURGIN. R.C.R.D. 0879.
- "BOUNDARY SURVEY LOCATED IN PORTSMOUTH, NH. PREPARED FOR TIDEWATCH ASSOCIATES, INC. DATED MARCH 13, 1986. PREPARED BY KIMBALL CHASE COMPANY, INC. R.C.R.D. 14771.

GENERAL LEGEND

- EXISTING PROPERTY LINE
- - - ABUTTER PROPERTY LINE
- PROPERTY LINE SETBACK
- - - PROPOSED LIMITED COMMON LINE
- EXISTING EDGE OF PAVEMENT
- - - PROPOSED EDGE OF PAVEMENT
- PROPOSED ROAD CENTERLINE
- IRON PIPE / IRON ROD
- DRILL HOLE
- IRON ROD TO BE SET

CONDOMINIUM SITE PLAN CERTIFICATION:

I CERTIFY THAT THIS PLAN FULLY AND ACCURATELY DEPICTS THE LOCATION AND DIMENSIONS OF THE LAND AND EXISTING IMPROVEMENTS SHOWN THEREON AND TO THE EXTENT FEASIBLE, ALL EASEMENTS APPURTENANT THERETO, THAT UNITS 1-4 ARE BEGUN BUT NOT YET COMPLETE, AND THIS PLAN COMPLIES WITH NH RSA 356-B20 (1).

PURSUANT TO RSA 676:18-III AND RSA 672:14 I CERTIFY THAT THIS SURVEY PLAT IS NOT A SUBDIVISION PURSUANT TO THIS TITLE AND THAT THE LINES OF STREETS AND WAYS SHOWN ARE THOSE OF PUBLIC OR PRIVATE STREETS OR WAYS ALREADY ESTABLISHED AND THAT NO NEW WAYS ARE SHOWN.

NEW STATE OF NEW HAMPSHIRE
 LAND SURVEYOR
 No. 1030
 MATTHEW J. SALVUCCI
 SIGNATURE

MATTHEW J. SALVUCCI, LLS 1030 DATE:
 ON BEHALF OF JONES & BEACH ENGINEERS, INC.

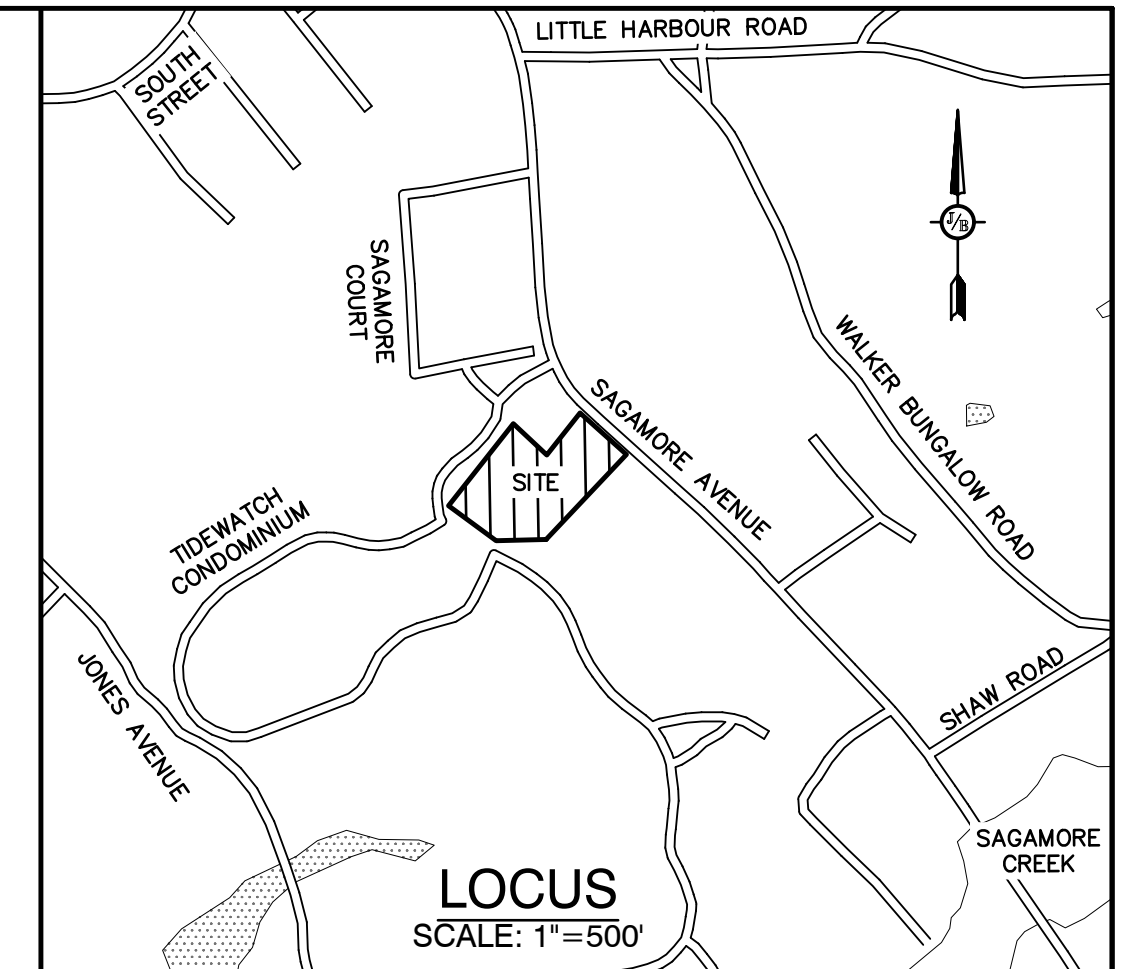

SITE NOTES:

- THE INTENT OF THIS PLAN IS TO REMOVE EXISTING STRUCTURES AND CONSTRUCT A 4-UNIT MULTI-FAMILY RESIDENTIAL DEVELOPMENT.
- ZONING DISTRICT: SINGLE RESIDENCE A (SRA)
 LOT AREA MINIMUM = 1 ACRE
 LOT FRONTAGE MINIMUM = 150'
 LOT DEPTH MINIMUM = 200'
 BUILDING SETBACKS (MINIMUM):
 FRONT SETBACK = 30'
 SIDE SETBACK = 20'
 REAR SETBACK = 40'
 WETLAND SETBACK = 100' FROM WETLANDS GREATER THAN 10,000 S.F.
 MAX. BUILDING HEIGHT = 35' FOR SLOPED ROOF; 30' FOR FLAT ROOF
 MAX. BUILDING COVERAGE = 10%
 BUILDING COVERAGE PROPOSED = 8,476 S.F. = JUST UNDER 10%
 MAX. DENSITY = 1 DWELLING UNIT / ACRE
 DENSITY PROPOSED = 4 DWELLING UNITS / 1.947 AC. = 2.05 UNITS / ACRE
 (1 UNIT / 21,248 S.F.)
 MIN. OPEN SPACE = 50%
 OPEN SPACE PROPOSED = 68,700 S.F. = 80.0%
- PARKING CALCULATIONS:
 DWELLING UNIT FLOOR AREA OVER 750 S.F. - 1.3 SPACES REQUIRED PER UNIT
 1.3 * 4 DWELLING UNITS = 5.2 SPACES REQUIRED
 2 SPACES IN GARAGE + 2 SPACES IN DRIVEWAY PER UNIT = 4 SPACES PER UNIT * 4 UNITS
 16 SPACES PROVIDED
 ONE BICYCLE SPACE PROVIDED IN EACH GARAGE (1 REQUIRED FOR EVERY 5 DWELLING UNITS PER ZONING)
- ON MAY 23, 2023, THE PORTSMOUTH, NH ZONING BOARD OF ADJUSTMENT VOTED TO APPROVE VARIANCES FROM THE FOLLOWING SECTIONS OF THE ZONING ORDINANCE:
 A) SECTION 10.513 - TO PERMIT MORE THAN ONE FREE-STANDING DWELLING ON A LOT
 B) SECTION 10.521 - TO PERMIT LESS THAN ONE ACRE PER DWELLING UNIT
- NHDES SEWER CONNECTION PERMIT NO. , DATED
- AS-BUILT CONDOMINIUM SITE AND FLOOR PLANS SHALL BE RECORDED.
- NO WETLANDS WERE OBSERVED WITHIN 100' OF THE PROPERTY BOUNDARY. SEE LETTER FROM GOVE ENVIRONMENTAL SERVICES, INC.
- BASIS OF BEARING:
 HORIZONTAL - NH STATE PLANE. VERTICAL - NAVD88.
- ALL BOOK AND PAGE NUMBERS REFER TO THE ROCKINGHAM COUNTY REGISTRY OF DEEDS.
- THE TAX MAP AND LOT NUMBERS ARE BASED ON THE CITY OF PORTSMOUTH TAX RECORDS AND ARE SUBJECT TO CHANGE.
- ALL LAND WITHIN THE LCA LINES WITH THE EXCEPTION OF THE BUILDING INTERIORS SHALL BE LIMITED COMMON AREA. LIMITED COMMON AREAS MAY BE ACCESSED BY THE ASSOCIATION FOR ANY WORK ASSOCIATED WITH UTILITIES, DRAINAGE, AND LANDSCAPING THAT IS DEEMED NECESSARY.
- THIS SURVEY IS NOT A CERTIFICATION TO OWNERSHIP OR TITLE OF LANDS SHOWN. OWNERSHIP AND ENCUMBRANCES ARE MATTERS OF TITLE EXAMINATION NOT OF A BOUNDARY SURVEY. THE INTENT OF THIS PLAN IS TO RETRACE THE BOUNDARY LINES OF DEEDS REFERENCED HEREON. OWNERSHIP OF ADJOINING PROPERTIES IS ACCORDING TO ASSESSOR'S RECORDS. THIS PLAN MAY OR MAY NOT INDICATE ALL ENCUMBRANCES EXPRESSED, IMPLIED OR PRESCRIPTIVE.
- SURVEY TIE LINES SHOWN HEREON ARE NOT BOUNDARY LINES. THEY SHOULD ONLY BE USED TO LOCATE THE PARCEL SURVEYED FROM THE FOUND MONUMENTS SHOWN AND LOCATED BY THIS SURVEY
- THIS PLAN SET HAS BEEN PREPARED BY JONES & BEACH ENGINEERS, INC., FOR MUNICIPAL AND STATE APPROVALS AND FOR CONSTRUCTION BASED ON DATA OBTAINED FROM ON-SITE FIELD SURVEY AND EXISTING MUNICIPAL RECORDS. THROUGHOUT THE CONSTRUCTION PROCESS, THE CONTRACTOR SHALL INFORM THE ENGINEER IMMEDIATELY OF ANY FIELD DISCREPANCY FROM DATA AS SHOWN ON THE DESIGN PLANS, INCLUDING ANY UNFORESEEN CONDITIONS, SUBSURFACE OR OTHERWISE, FOR EVALUATION AND RECOMMENDATIONS. ANY CONTRADICTION BETWEEN ITEMS ON THIS PLAN/PLAN SET, OR BETWEEN THE PLANS AND ON-SITE CONDITIONS, MUST BE RESOLVED BEFORE RELATED CONSTRUCTION HAS BEEN INITIATED. CONTRACTOR TO ALWAYS CONTACT DIG SAFE PRIOR TO DIGGING ONSITE OR OFFSITE TO ENSURE SAFETY AND OBEY THE LAW.
- THIS PLAN IS THE RESULT OF A CLOSED TRAVERSE WITH A RAW, UNADJUSTED LINEAR ERROR OF CLOSURE GREATER THAN 1 IN 15,000
- SUBJECT PROPERTY IS NOT LOCATED WITHIN FEDERALLY DESIGNATED 100 YEAR FLOOD HAZARD ZONE. REFERENCE FEMA COMMUNITY PANEL NO. 3301SC0270F, DATED JANUARY 29, 2021.
- AN ACCESS EASEMENT SHALL BE GRANTED TO THE CITY OF PORTSMOUTH FOR ACCESS AND LEAK DETECTION OF THE WATER MAIN, SHUTOFFS, AND METERS ON THE PROPERTY. EASEMENT DESCRIPTION MUST BE APPROVED BY THE CITY'S LEGAL DEPARTMENT AND ACCEPTED BY THE CITY COUNCIL.
- ALL IMPROVEMENTS SHOWN ON THIS SITE PLAN SHALL BE CONSTRUCTED AND MAINTAINED IN ACCORDANCE WITH THE PLAN BY THE PROPERTY OWNER AND ALL FUTURE PROPERTY OWNERS. NO CHANGES SHALL BE MADE TO THE SITE PLAN WITHOUT THE EXPRESS APPROVAL OF THE PORTSMOUTH PLANNING DIRECTOR.
- THIS SITE PLAN SHALL BE RECORDED IN THE ROCKINGHAM COUNTY REGISTRY OF DEEDS.
- ALL CONDITIONS ON THIS PLAN SHALL REMAIN IN EFFECT IN PERPETUITY PURSUANT TO THE REQUIREMENTS OF THE SITE PLAN REVIEW REGULATIONS.
- THE OWNER OF EACH UNIT SHALL STORE TRASH IN THEIR GARAGE. TRASH WILL BE PICKED UP BY A PRIVATE HAULER.
- THE SUBJECT PARCEL IS NOT LOCATED WITHIN A WELLHEAD PROTECTION OR AQUIFER PROTECTION AREA PER NHDES ONESTOP DATA.
- THE IMPROVEMENTS SHOWN HEREON HAVE NOT YET BEEN CONSTRUCTED.

GRAPHIC SCALE

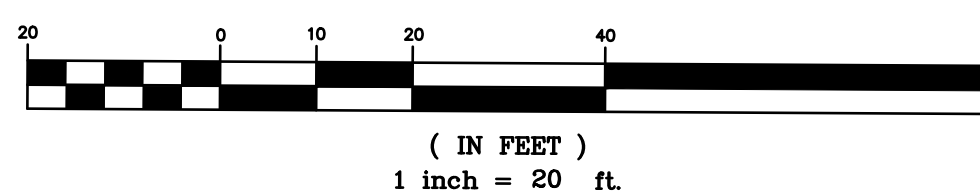

MAP 222 LOT 18
 THOMAS NICHOLSON
 695 SAGAMORE AVENUE
 PORTSMOUTH, NH 03801
 BK 3204 PG 2852

TAX MAP 222, LOT 20
 EVAN W. PATTEN
 607 SAGAMORE AVE
 PORTSMOUTH, NH 03801
 BK 5469 PG 806

CITY OF PORTSMOUTH PLANNING BOARD

CHAIRPERSON DATE

Design: DJM Draft: KDR Date: 2/26/2024
 Checked: JAC Scale: AS NOTED Project No.: 18134.1
 Drawing Name: 18134.1-PLAN.dwg

THIS PLAN SHALL NOT BE MODIFIED WITHOUT WRITTEN PERMISSION FROM JONES & BEACH ENGINEERS, INC. (JBE). ANY ALTERATIONS, AUTHORIZED OR OTHERWISE, SHALL BE AT THE USER'S SOLE RISK AND WITHOUT LIABILITY TO JBE.

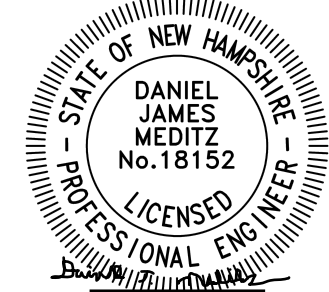

REV.	DATE	REVISION	BY
1	4/19/24	REVISED PER TAC COMMENTS	DJM
0	3/18/24	ISSUED FOR REVIEW	KDR

Designed and Produced in NH

J/B Jones & Beach Engineers, Inc.

85 Portsmouth Ave. Civil Engineering Services 603-772-4746
 PO Box 219 FAX: 603-772-0227
 Stratham, NH 03885 E-MAIL: JBE@JONESANDBEACH.COM

Plan Name: **CONDOMINIUM SITE PLAN**

Project: **LUSTER CLUSTER**
635 SAGAMORE AVE., PORTSMOUTH, NH

Owner of Record: **3612 LAFAYETTE RD., DEPT 4, PORTSMOUTH, NH 03801 BK 6332 PG 1158**

DRAWING No. **CS1**

SHEET 5 OF 20
 JBE PROJECT NO. 18134.1

PROJECT PARCEL
 CITY OF PORTSMOUTH
 TAX MAP 222, LOT 19

TOTAL LOT AREA
 84,795 SQ. FT.
 1.95 ACRES

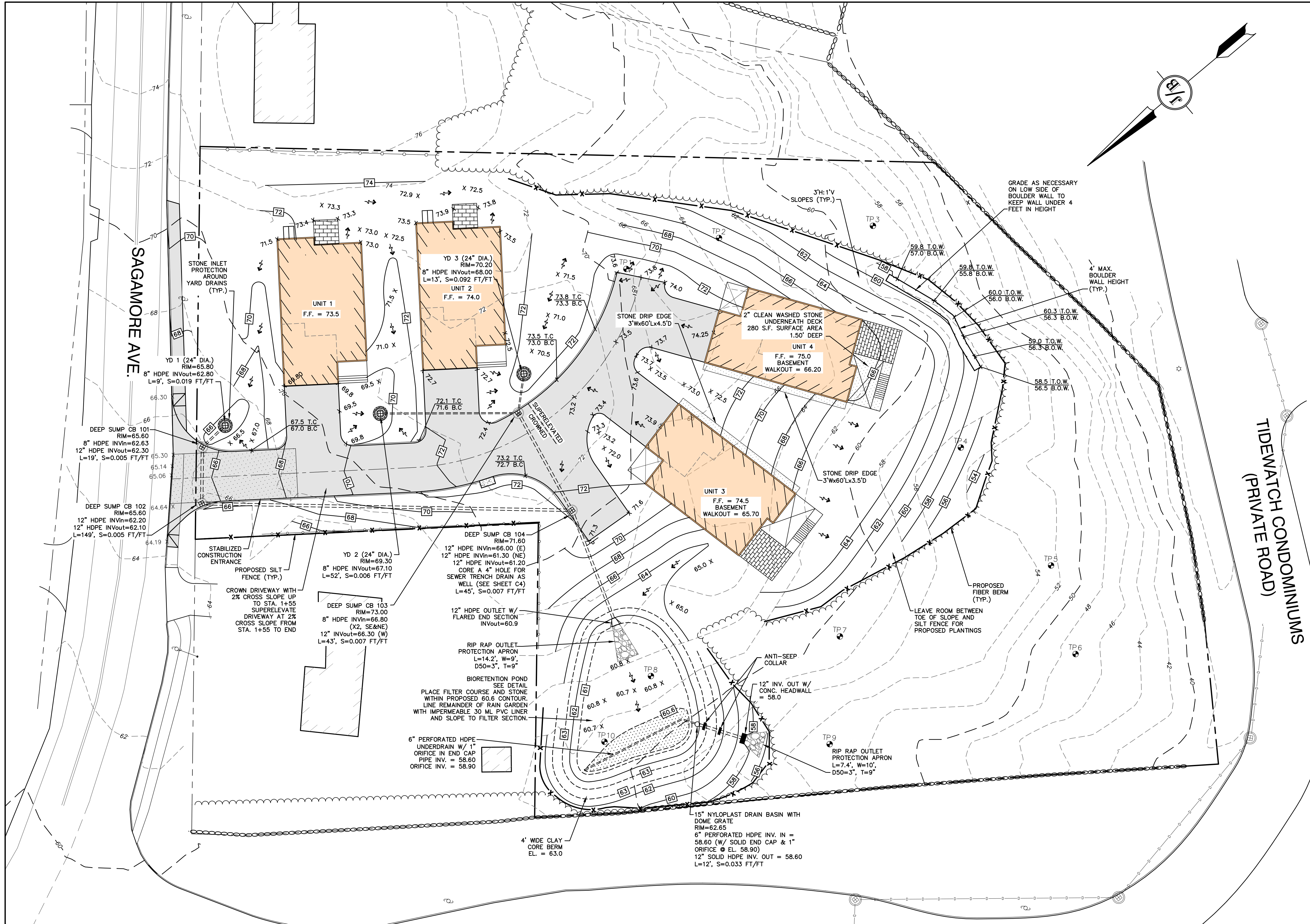

GRADING AND DRAINAGE NOTES:

- UNDERGROUND FACILITIES, UTILITIES AND STRUCTURES HAVE BEEN PLOTTED FROM FIELD OBSERVATION AND THEIR LOCATION MUST BE CONSIDERED APPROXIMATE ONLY. NEITHER JONES & BEACH ENGINEERS, INC., NOR ANY OF THEIR EMPLOYEES TAKE RESPONSIBILITY FOR THE LOCATION OF ANY UNDERGROUND STRUCTURES AND/OR UTILITIES NOT SHOWN THAT MAY EXIST. IT IS THE RESPONSIBILITY OF THE CONTRACTOR TO HAVE ALL UNDERGROUND STRUCTURES AND/OR UTILITIES LOCATED PRIOR TO EXCAVATION WORK BY CALLING 888-DIG-SAFE (888-344-7233).
- VERTICAL DATUM: NAVD88.
- ALL BENCHMARKS AND TOPOGRAPHY SHALL BE FIELD VERIFIED BY THE CONTRACTOR.
- SITE GRADING SHALL NOT PROCEED UNTIL EROSION CONTROL MEASURES HAVE BEEN INSTALLED. SEE CONSTRUCTION SEQUENCE ON SHEET E1.
- PRIOR TO THE START OF CONSTRUCTION, THE CONTRACTOR IS REQUIRED TO HAVE THE PROJECT'S LAND SURVEYOR STAKE OR FLAG CLEARING LIMITS. A MINIMUM OF 48 HOURS NOTICE IS REQUIRED.
- ALL SWALES AND STORMWATER PONDS SHALL BE STABILIZED PRIOR TO DIRECTING RUNOFF TO THEM.
- PROPOSED RIM ELEVATIONS OF DRAINAGE STRUCTURES ARE APPROXIMATE. FINAL ELEVATIONS ARE TO BE SET FLUSH WITH FINISH GRADES.
- ALL DRAINAGE AND SANITARY STRUCTURE INTERIOR DIAMETERS (4" MIN) SHALL BE DETERMINED BY THE MANUFACTURER BASED ON THE PIPE CONFIGURATIONS SHOWN ON THESE PLANS. CATCH BASINS SHALL HAVE 4" DEEP SUMPS WITH GREASE HOODS, UNLESS OTHERWISE NOTED.
- ALL DRAINAGE STRUCTURES SHALL BE PRECAST, UNLESS OTHERWISE SPECIFIED. SEE DETAIL SHEETS FOR DRAINAGE DETAILS.
- ALL DRAINAGE STRUCTURES AND STORMWATER PIPES SHALL MEET HEAVY DUTY TRAFFIC H20 LOADING AND SHALL BE INSTALLED ACCORDINGLY.
- IN AREAS WHERE CONSTRUCTION IS PROPOSED ADJACENT TO ABUTTING PROPERTIES, THE CONTRACTOR SHALL INSTALL ORANGE CONSTRUCTION FENCING ALONG PROPERTY LINES IN ALL AREAS WHERE SILT FENCING IS NOT REQUIRED.
- ALL DRAINAGE PIPE SHALL BE NON-PERFORATED ADS N-12 OR APPROVED EQUAL.
- STONE INLET PROTECTION SHALL BE PLACED AT ALL CATCH BASINS AND YARD DRAINS. SEE DETAIL WITHIN THE DETAIL SHEETS.
- LAND DISTURBING ACTIVITIES SHALL NOT COMMENCE UNTIL APPROVAL TO DO SO HAS BEEN RECEIVED BY ALL GOVERNING AUTHORITIES. THE GENERAL CONTRACTOR SHALL STRICTLY ADHERE TO THE EPA SWPPP DURING CONSTRUCTION OPERATIONS.
- ALL EXPOSED AREAS SHALL BE SEEDED AS SPECIFIED WITHIN 3 DAYS OF FINAL GRADING AND ANYTIME CONSTRUCTION STOPS FOR LONGER THAN 3 DAYS.
- MAINTAIN EROSION CONTROL MEASURES AFTER EACH RAIN EVENT OF 0.25" OR GREATER IN A 24 HOUR PERIOD AND AT LEAST ONCE A WEEK.
- THIS PLAN SHALL NOT BE CONSIDERED ALL INCLUSIVE, AS THE GENERAL CONTRACTOR SHALL TAKE ALL NECESSARY PRECAUTIONS TO PREVENT SEDIMENT FROM LEAVING THE SITE.
- CONSTRUCTION VEHICLES SHALL UTILIZE THE STABILIZED THROUGHOUT CONSTRUCTION.
- IF INSTALLATION OF STORM DRAINAGE SYSTEM SHOULD BE INTERRUPTED BY WEATHER OR NIGHTFALL, THE PIPE ENDS SHALL BE COVERED WITH FILTER FABRIC.
- THE GENERAL CONTRACTOR SHALL BE RESPONSIBLE TO TAKE WHATEVER MEANS NECESSARY TO ESTABLISH PERMANENT SOIL STABILIZATION.
- SEDIMENT SHALL BE REMOVED FROM ALL SEDIMENT BASINS BEFORE THEY ARE 25% FULL.
- ALL WORK SHALL BE DONE IN STRICT ACCORDANCE WITH PROJECT SPECIFICATIONS.
- ADDITIONAL EROSION AND SEDIMENT CONTROL MEASURES SHALL BE INSTALLED, IF DEEMED NECESSARY BY ON-SITE INSPECTION BY ENGINEER AND/OR REGULATORY OFFICIALS.
- SEE ALSO EROSION AND SEDIMENT CONTROL SPECIFICATIONS ON SHEET E1.
- CB = CATCH BASIN, YD = YARD DRAIN

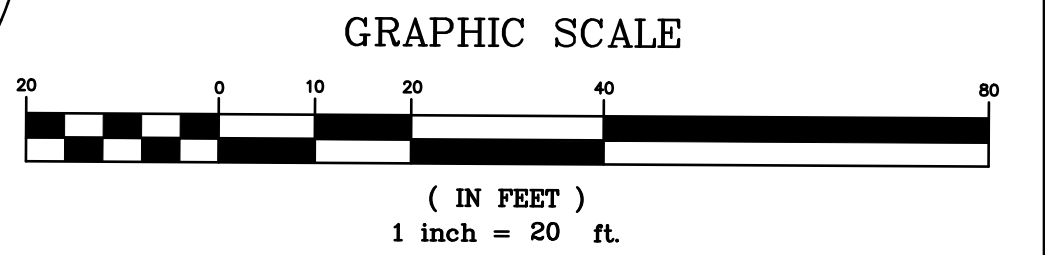

PROJECT PARCEL CITY OF PORTSMOUTH TAX MAP 222, LOT 19
TOTAL LOT AREA 84,795 SQ. FT. 1.95 ACRES

Design: DJM Draft: KDR Date: 2/26/2024
 Checked: JAC Scale: AS NOTED Project No.: 18134.1
 Drawing Name: 18134.1-PLAN.dwg
 THIS PLAN SHALL NOT BE MODIFIED WITHOUT WRITTEN PERMISSION FROM JONES & BEACH ENGINEERS, INC. (JBE). ANY ALTERATIONS, AUTHORIZED OR OTHERWISE, SHALL BE AT THE USER'S SOLE RISK AND WITHOUT LIABILITY TO JBE.

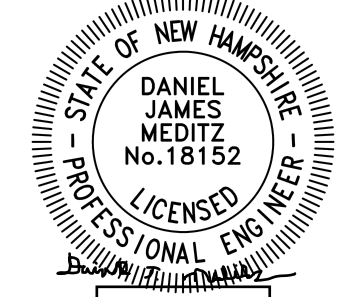

REV.	DATE	REVISION	BY
1	4/19/24	REVISED PER TAC COMMENTS	DJM
0	3/18/24	ISSUED FOR REVIEW	KDR

Designed and Produced in NH

J/B Jones & Beach Engineers, Inc.

85 Portsmouth Ave. Civil Engineering Services 603-772-4746
 PO Box 219 Stratham, NH 03885 E-MAIL: JBE@JONESANDBEACH.COM

Plan Name: **GRADING AND DRAINAGE PLAN**

Project: **LUSTER CLUSTER
635 SAGAMORE AVE., PORTSMOUTH, NH**

Owner of Record: 3612 LAFAYETTE RD., DEPT 4, PORTSMOUTH, NH 03801 BK 6332 PG 1158

DRAWING No. **C3**

SHEET 6 OF 20
JBE PROJECT NO. 18134.1

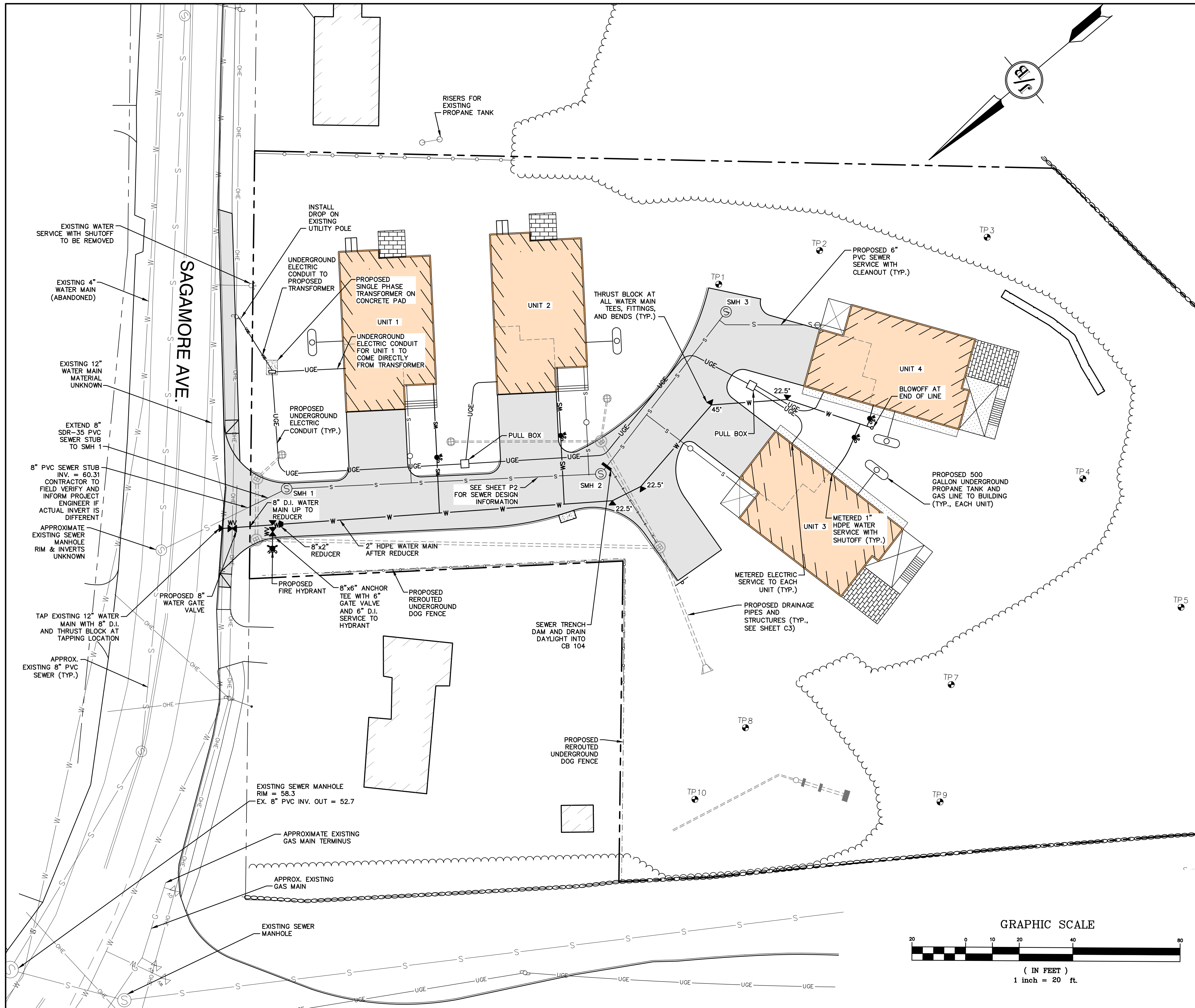

UTILITY NOTES:

- PRIOR TO THE START OF CONSTRUCTION, THE CONTRACTOR SHALL COORDINATE WITH THE ENGINEER, ARCHITECT AND/OR OWNER, IN ORDER TO OBTAIN AND/OR PAY ALL THE NECESSARY LOCAL PERMITS, CONNECTION FEES AND BONDS.
- THE CONTRACTOR SHALL PROVIDE A MINIMUM NOTICE OF FOURTEEN (14) DAYS TO ALL CORPORATIONS, COMPANIES AND/OR LOCAL AUTHORITIES OWNING OR HAVING A JURISDICTION OVER UTILITIES RUNNING TO, THROUGH OR ACROSS PROJECT AREAS PRIOR TO DEMOLITION AND/OR CONSTRUCTION ACTIVITIES.
- THE LOCATION, SIZE, DEPTH AND SPECIFICATIONS FOR CONSTRUCTION OF PROPOSED PRIVATE UTILITY SERVICES SHALL BE TO THE STANDARDS AND REQUIREMENTS OF THE RESPECTIVE UTILITY COMPANY (ELECTRIC, TELEPHONE, CABLE TELEVISION, WATER, AND SEWER).
- A PRECONSTRUCTION MEETING SHALL BE HELD WITH THE OWNER, ENGINEER, ARCHITECT, CONTRACTOR, LOCAL OFFICIALS, AND ALL PROJECT-RELATED UTILITY COMPANIES (PUBLIC AND PRIVATE) PRIOR TO START OF CONSTRUCTION.
- ALL CONSTRUCTION SHALL CONFORM TO THE CITY STANDARDS AND REGULATIONS, AND NHDES STANDARDS AND SPECIFICATIONS, WHICHEVER ARE MORE STRINGENT, UNLESS OTHERWISE SPECIFIED.
- ALL CONSTRUCTION ACTIVITIES SHALL CONFORM TO LABOR OCCUPATIONAL SAFETY AND HEALTH ADMINISTRATION (OSHA) RULES AND REGULATIONS.
- BUILDINGS TO BE SERVED BY UNDERGROUND UTILITIES UNLESS OTHERWISE NOTED.
- AS-BUILT PLANS SHALL BE SUBMITTED TO DEPARTMENT OF PUBLIC WORKS.
- INVERTS AND SHELVES: MANHOLES SHALL HAVE A BRICK PAVED SHELF AND INVERT, CONSTRUCTED TO CONFORM TO THE SIZE OF PIPE AND FLOW AT CHANGES IN DIRECTION. THE INVERTS SHALL BE LAID OUT IN CURVES OF THE LONGEST RADIUS POSSIBLE TANGENT TO THE CENTER LINE OF THE SEWER PIPES. SHELVES SHALL BE CONSTRUCTED TO THE ELEVATION OF THE THROUGH CHANNEL UNDERLAYMENT OF INVERT, AND SHELF SHALL CONSIST OF BRICK MASONRY.
- SHALLOW MANHOLE: IN LIEU OF A CONE SECTION, WHEN MANHOLE DEPTH IS LESS THAN 6 FEET, A REINFORCED CONCRETE SLAB COVER MAY BE USED HAVING AN ECCENTRIC ENTRANCE OPENING AND CAPABLE OF SUPPORTING H2O LOADS. (THIS APPLIES TO SMH 1)
- CONTRACTOR SHALL PLACE 2" WIDE METAL WIRE IMPREGNATED RED PLASTIC WARNING TAPE OVER ENTIRE LENGTH OF ALL GRAVITY SEWERS, SERVICES, AND FORCE MAINS.
- SANITARY SEWER FLOW CALCULATIONS:
4 - FOUR BEDROOM UNITS. ASSUME 5 PEOPLE IN 4-BEDROOM UNITS.
PER METCALF & EDDY TABLE 3-2: 61 GPD/PERSON IN 5 PERSON HOUSE
(61 GPD * 5 PEOPLE * 4) = 1,220 GPD. SEE SHEET 2 FOR BEDROOM NUMBER DESIGNATION.
- ALL SANITARY STRUCTURE INTERIOR DIAMETERS (4' MIN) SHALL BE DETERMINED BY THE MANUFACTURER BASED ON THE PIPE CONFIGURATIONS SHOWN ON THESE PLANS.
- PROPOSED RIM ELEVATIONS OF DRAINAGE AND SANITARY MANHOLES ARE APPROXIMATE. FINAL ELEVATIONS ARE TO BE SET FLUSH WITH FINISH GRADES. ADJUST ALL OTHER RIM ELEVATIONS OF MANHOLES, WATER GATES, AND OTHER UTILITIES TO FINISH GRADE AS SHOWN ON THE GRADING AND DRAINAGE PLAN.
- ALL WATER MAINS AND SERVICE PIPES SHALL HAVE A MINIMUM 12" VERTICAL AND 24" HORIZONTAL SEPARATION TO MANHOLES, OR CONTRACTOR SHALL INSTALL BOARD INSULATION FOR FREEZING PROTECTION.
- WATER MAINS SHALL BE HYDROSTATICALLY PRESSURE TESTED FOR LEAKAGE PRIOR TO ACCEPTANCE. WATERMANS SHALL BE TESTED AT 1.5 TIMES THE WORKING PRESSURE OR 150 PSI, WHICHEVER IS GREATER. TESTING SHALL BE CONDUCTED IN ACCORDANCE WITH SECTION 4 OF AWWA STANDARD C 600. WATERMANS SHALL BE DISINFECTED AFTER THE ACCEPTANCE OF THE PRESSURE AND LEAKAGE TESTS ACCORDING TO AWWA STANDARD C 651.
- ALL WATER AND SANITARY LEADS TO BUILDING(S) SHALL END 5' OUTSIDE THE BUILDING LIMITS AS SHOWN ON PLANS AND SHALL BE PROVIDED WITH A TEMPORARY PLUG AND WITNESS AT END.
- THRUST BLOCKS SHALL BE PROVIDED AT ALL BENDS, TEES, MECHANICAL JOINTS AND FIRE HYDRANTS.
- DIMENSIONS ARE SHOWN TO CENTERLINE OF PIPE OR FITTING.
- CONTRACTOR TO FURNISH SHOP DRAWINGS FOR UTILITY RELATED ITEMS TO ENSURE CONFORMANCE WITH THE PLANS AND SPECIFICATIONS. SHOP DRAWINGS SHOULD BE SENT IN TRIPLICATE TO THE DESIGN ENGINEER FOR REVIEW AND APPROVAL PRIOR TO INSTALLATION.
- EXISTING UTILITIES SHALL BE DIGSAFED BEFORE CONSTRUCTION.
- ALL WATER LINES SHALL HAVE TESTABLE BACKFLOW PREVENTERS AT THE ENTRANCE TO EACH BUILDING.
- ALL GRAVITY SEWER PIPE, MANHOLES, AND FORCE MAINS SHALL BE TESTED ACCORDING TO NHDES STANDARDS OF DESIGN AND CONSTRUCTION FOR SEWAGE AND WASTEWATER TREATMENT FACILITIES, CHAPTER ENV-WQ 700. ADOPTED ON 10-15-14.
- ENV-WQ 704.06 GRAVITY SEWER PIPE TESTING: GRAVITY SEWERS SHALL BE TESTED FOR WATER TIGHTNESS BY USE OF LOW-PRESSURE AIR TESTS CONFORMING WITH ASTM F1417-92(2005) OR UNI-BELL PVC PIPE ASSOCIATION UNI-B-6. LINES SHALL BE CLEANED AND VISUALLY INSPECTED AND TRUE TO LINE AND GRADE. DEFLECTION TESTS SHALL TAKE PLACE AFTER 30 DAYS FOLLOWING INSTALLATION AND THE MAXIMUM ALLOWABLE DEFLECTION OF FLEXIBLE SEWER PIPE SHALL BE 5% OF AVERAGE INSIDE DIAMETER. A RIGID BALL OR MANDREL WITH A DIAMETER OF AT LEAST 95% OF THE AVERAGE INSIDE PIPE DIAMETER SHALL BE USED FOR TESTING PIPE DEFLECTION. THE DEFLECTION TEST SHALL BE CONDUCTED WITHOUT MECHANICAL PULLING DEVICES.
- ENV-WQ 704.17 SEWER MANHOLE TESTING: SHALL BE TESTED FOR LEAKAGE USING A VACUUM TEST PRIOR TO BACKFILLING AND PLACEMENT OF SHELVES AND INVERTS.
- SANITARY SEWER LINES SHALL BE LOCATED AT LEAST TEN (10) FEET HORIZONTALLY FROM AN EXISTING OR PROPOSED WATER LINE. WHEN A SEWER LINE CROSSES UNDER A WATER LINE, THE SEWER PIPE JOINTS SHALL BE LOCATED AT LEAST 6 FEET HORIZONTALLY FROM THE WATERMAIN. THE SEWER LINE SHALL ALSO MAINTAIN A VERTICAL SEPARATION OF NOT LESS THAN 18 INCHES.
- SEWERS SHALL BE BURIED TO A MINIMUM DEPTH OF 6 FEET BELOW GRADE IN ALL ROADWAY LOCATIONS, AND TO A MINIMUM DEPTH OF 4 FEET BELOW GRADE IN ALL CROSS-COUNTRY LOCATIONS. PROVIDE TWO-INCHES OF R-10 FOAM BOARD INSULATION 2-FOOT WIDE TO BE INSTALLED 6-INCHES OVER SEWER PIPE IN AREAS WHERE DEPTH IS NOT ACHIEVED. A WAIVER FROM THE DEPARTMENT OF ENVIRONMENTAL SERVICES WASTEWATER ENGINEERING BUREAU IS REQUIRED PRIOR TO INSTALLING SEWER AT LESS THAN MINIMUM COVER.
- THE CONTRACTOR SHALL MINIMIZE THE DISRUPTIONS TO THE EXISTING SEWER FLOWS AND THOSE INTERRUPTIONS SHALL BE LIMITED TO FOUR (4) HOURS OR LESS AS DESIGNATED BY THE CITY SEWER DEPARTMENT.
- LIGHTING CONDUIT SHALL BE SCHEDULE 40 PVC, AND SHALL BE INSTALLED IN CONFORMANCE WITH THE NATIONAL ELECTRIC CODE. CONTRACTOR SHALL PROVIDE EXCAVATION AND BACKFILL.
- ALL TRENCHING, PIPE LAYING, AND BACKFILLING SHALL BE IN ACCORDANCE WITH FEDERAL OSHA REGULATIONS.
- DISINFECTION OF WATER MAINS SHALL BE CARRIED OUT IN STRICT ACCORDANCE WITH AWWA STANDARD C651, LATEST EDITION. THE BASIC PROCEDURE TO BE FOLLOWED FOR DISINFECTING WATER MAINS IS AS FOLLOWS:
a. PREVENT CONTAMINATING MATERIALS FROM ENTERING THE WATER MAIN DURING STORAGE, CONSTRUCTION, OR REPAIR.
b. REMOVE, BY FLUSHING OR OTHER MEANS, THOSE MATERIALS THAT MAY HAVE ENTERED THE WATER MAINS.
c. CHLORINATE ANY RESIDUAL CONTAMINATION THAT MAY REMAIN, AND FLUSH THE CHLORINATED WATER FROM THE MAIN.
d. PROTECT THE EXISTING DISTRIBUTION SYSTEM FROM BACKFLOW DUE TO HYDROSTATIC PRESSURE TEST AND DISINFECTION PROCEDURES.
e. DETERMINE THE BACTERIOLOGICAL QUALITY BY LABORATORY TEST AFTER DISINFECTION.
f. MAKE FINAL CONNECTION OF THE APPROVED NEW WATER MAIN TO THE ACTIVE DISTRIBUTION SYSTEM
- DOMESTIC SHUTOFFS & VALVES SHALL BE PAINTED BLUE. FIRE SERVICE SHUTOFFS & VALVES SHALL BE PAINTED RED. COORDINATE WITH CITY OF PORTSMOUTH DEPARTMENT OF PUBLIC WORKS FOR EXACT COLORS.
- SEWER TRENCH DAMS SHALL BE INSTALLED EVERY 75' ALONG GRAVITY SEWER PIPE.
- IF IRRIGATION IS TO BE USED, THE PIPING SYSTEM SHALL BE REVIEWED AND APPROVED BY THE PORTSMOUTH CITY PLANNER, CITY ENGINEER, AND THE WATER DEPARTMENT PRIOR TO INSTALLATION.
- WATER LINE TO BE CONSTRUCTED PER CITY OF PORTSMOUTH SPECIFICATIONS.
- AN AS-BUILT PLAN OF THE WATER LINE IS TO BE PREPARED AND SUBMITTED TO THE CITY OF PORTSMOUTH DEPARTMENT OF PUBLIC WORKS.

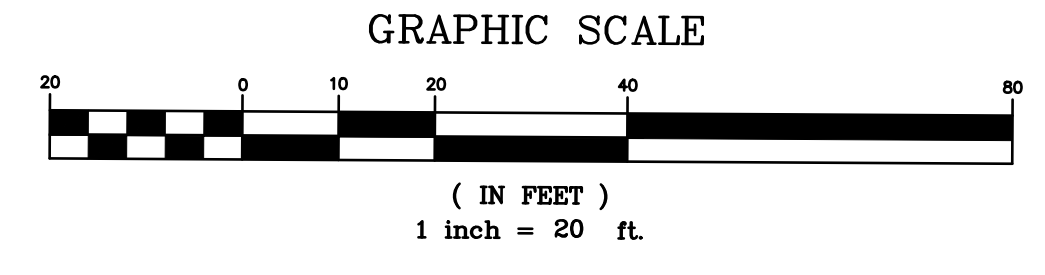

PROJECT PARCEL
CITY OF PORTSMOUTH
TAX MAP 222, LOT 19

TOTAL LOT AREA
84,795 SQ. FT.
1.95 ACRES

Design: DJM Draft: KDR Date: 2/26/2024
Checked: JAC Scale: AS NOTED Project No.: 18134.1
Drawing Name: 18134.1-PLAN.dwg

THIS PLAN SHALL NOT BE MODIFIED WITHOUT WRITTEN PERMISSION FROM JONES & BEACH ENGINEERS, INC. (JBE). ANY ALTERATIONS, AUTHORIZED OR OTHERWISE, SHALL BE AT THE USER'S SOLE RISK AND WITHOUT LIABILITY TO JBE.

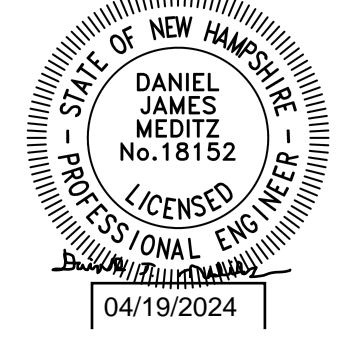

REV.	DATE	REVISION	BY
1	4/19/24	REVISED PER TAC COMMENTS	DJM
0	3/18/24	ISSUED FOR REVIEW	KDR

Designed and Produced in NH

J/B Jones & Beach Engineers, Inc.

85 Portsmouth Ave. Civil Engineering Services 603-772-4746
PO Box 219 Stratham, NH 03885 FAX: 603-772-0227
E-MAIL: JBE@JONESANDBEACH.COM

Plan Name: **UTILITY PLAN**

Project: **LUSTER CLUSTER**
635 SAGAMORE AVE., PORTSMOUTH, NH

Owner of Record: 3612 LAFAYETTE RD., DEPT 4, PORTSMOUTH, NH 03801 BK 6332 PG 1158
635 SAGAMORE DEVELOPMENT LLC

DRAWING No. **C4**

SHEET 7 OF 20
JBE PROJECT NO. 18134.1

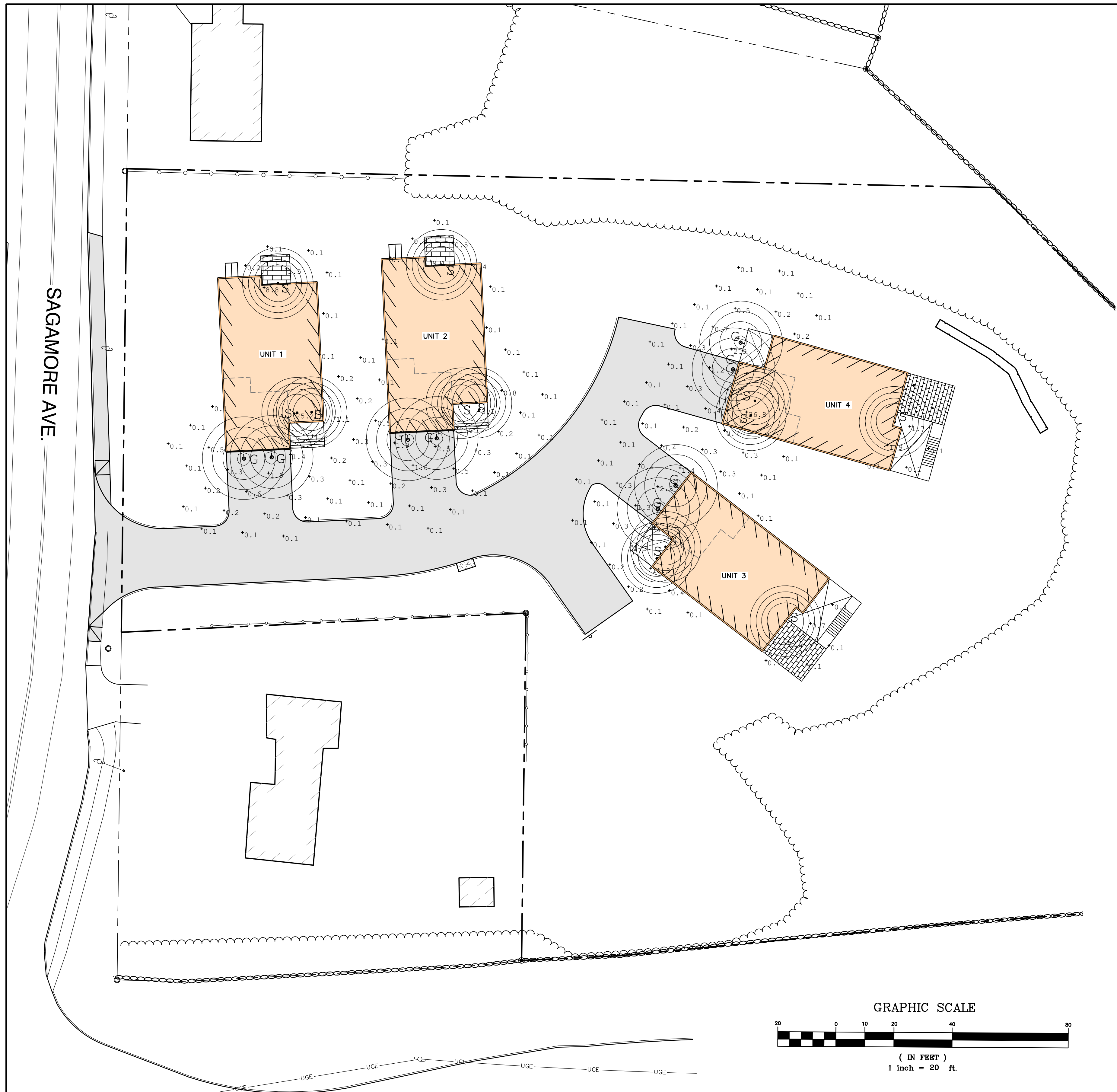

SAGAMORE AVE.

- LIGHTING AND ELECTRICAL NOTES:**
1. SITE ELECTRICAL CONTRACTOR SHALL COORDINATE LOCATION OF EASEMENTS, UNDERGROUND UTILITIES AND DRAINAGE BEFORE DRILLING POLE BASES.
 2. CONTRACTOR SHALL INSTALL PROPOSED LIGHT POLES ACCORDING TO TOWN REGULATIONS.
 3. ALL OUTDOOR LIGHTING SYSTEMS SHALL BE EQUIPPED WITH TIMERS TO REDUCE ILLUMINATION LEVELS TO NON-OPERATIONAL VALUES PER TOWN REGULATIONS.
 4. LIGHTING CONDUIT SHALL BE SCHEDULE 40 PVC, AND SHALL BE INSTALLED IN CONFORMANCE WITH THE NATIONAL ELECTRICAL CODE. CONTRACTOR SHALL PROVIDE EXCAVATION AND BACKFILL.
 5. ILLUMINATION READINGS SHOWN ARE BASED ON A TOTAL LLF OF 0.75 AT GRADE. ILLUMINATION READINGS SHOWN ARE IN UNITS OF FOOT-CANDELS.
 6. LIGHTING CALCULATIONS SHOWN ARE NOT A SUBSTITUTE FOR INDEPENDENT ENGINEERING ANALYSIS OF LIGHTING SYSTEM AND SAFETY.
 7. ALL LIGHTING FIXTURES SHALL BE FULL CUT-OFF DARK-SKY COMPLIANT, UNLESS OTHERWISE NOTED.
 8. THE PROPOSED LIGHTING CALCULATIONS AND DESIGN WAS PERFORMED BY EXPOSURE LIGHTING, 501 ISLINGTON ST, UNIT 1A, PORTSMOUTH, NH 03801, ATTENTION KEN SWEENEY. ALL LIGHTS SHOULD BE PURCHASED FROM THIS COMPANY OR AN EQUAL LIGHTING DESIGN SHALL BE SUBMITTED FOR REVIEW IF EQUAL SUBSTITUTIONS ARE PROPOSED BY THE CONTRACTOR OR OWNER.

UAA-30146
Atlantic 7 Small Shade Surface

Construction
A small and medium size shade decorative wall lantern with symmetrical light distribution. Developed to complement the Atlantic board and Atlantic pillar light. Designed for lighting of entrances and footpaths. Custom wattages can be provided to suit customer and Title 24 requirements. (Specify total watts per fixture)All Ligman fixtures can be manufactured using a special pre-treatment and coating process that ensures the fixture can be installed in natoratoriums as well as environments with high concentrations of chlorine or salt and still maintain the 5 year warranty. For this natoratorium rated process please specify NAT in options.

Additional Options (Consult Factory For Pricing)
SCPT
Surface Control Box Trim

UCI-30131
Cinatti Type I, II, III & IV Surface

Construction
A cone shaped wall wash luminaire. Suitable for outdoor up, or down light applications. This luminaire is provided with precision optics and high powered LEDs, to provide narrow, medium, wide and very wide distributions. The vandal resistant tempered glass is available in clear or lightly frosted versions. This product is suitable for commercial, as well as residential applications and with the selection of optics available can provide an excellent lighting solution. Integral electronic driver. Fixture is mounted over a 3" octagonal junction box. To meet International Dark Sky criteria, 3000K or warmer LEDs must be selected and luminaire fix mounted (+/- 15° allowable to permit leveling).

Additional Options (Consult Factory For Pricing)
SCPT
Surface Control Box Trim

Luminaire Schedule

Symbol	Qty	Label	Arrangement	Description	Tag	[MANUFAC]
	8	G	Single	UAA-30146-29W-2-1-W27-01	MOUNTED OVER GARAGE DOORS	LIGMAN
	12	S	Single	UCI-30131-21W-VW-W27-01	MOUNTED AT HOUSE DOORS	LIGMAN

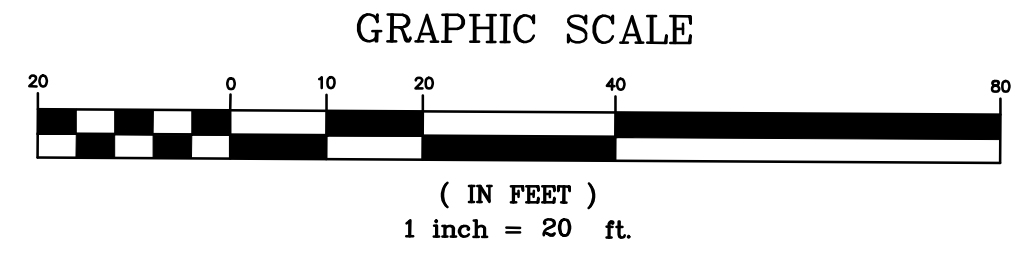

PROJECT PARCEL
CITY OF PORTSMOUTH
TAX MAP 222, LOT 19

TOTAL LOT AREA
84,795 SQ. FT.
1.95 ACRES

Design: DJM Draft: KDR Date: 2/26/2024
Checked: JAC Scale: AS NOTED Project No.: 18134.1
Drawing Name: 18134.1-PLAN.dwg
THIS PLAN SHALL NOT BE MODIFIED WITHOUT WRITTEN PERMISSION FROM JONES & BEACH ENGINEERS, INC. (JBE). ANY ALTERATIONS, AUTHORIZED OR OTHERWISE, SHALL BE AT THE USER'S SOLE RISK AND WITHOUT LIABILITY TO JBE.

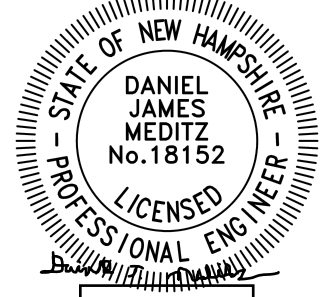

REV.	DATE	REVISION	BY
1	4/19/24	REVISED PER TAC COMMENTS	DJM
0	3/18/24	ISSUED FOR REVIEW	KDR
REV.	DATE	REVISION	BY

Designed and Produced in NH
J/B Jones & Beach Engineers, Inc.
85 Portsmouth Ave. Civil Engineering Services 603-772-4746
PO Box 219 Stratham, NH 03885 E-MAIL: JBE@JONESANDBEACH.COM

Plan Name: **LIGHTING PLAN**
Project: **LUSTER CLUSTER
635 SAGAMORE AVE., PORTSMOUTH, NH**
Owner of Record: 3612 LAFAYETTE RD., DEPT 4, PORTSMOUTH, NH 03801 BK 6332 PG 1158

DRAWING No.
L1
SHEET 8 OF 20
JBE PROJECT NO. 18134.1

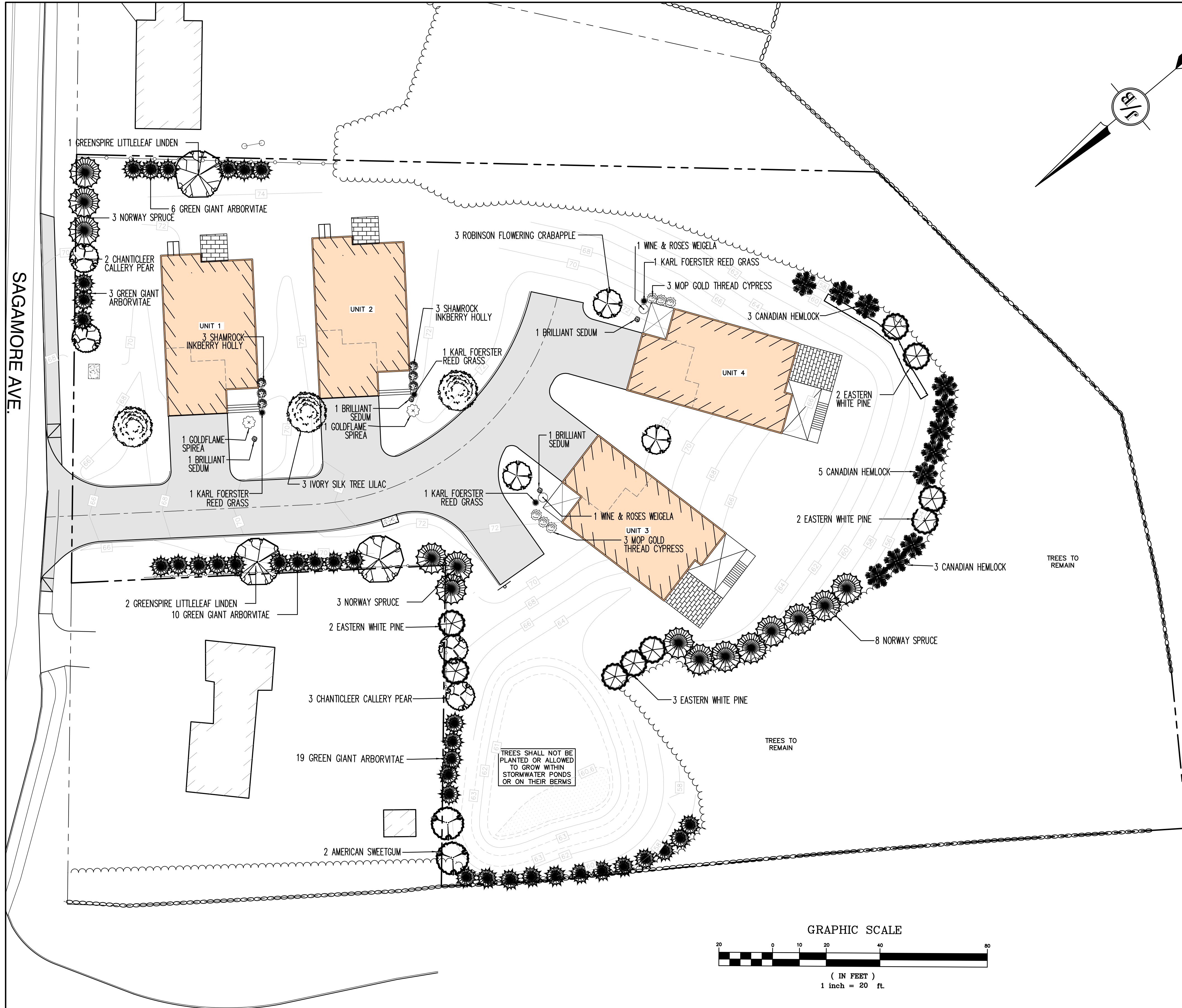

LANDSCAPE NOTES:

1. THE CONTRACTOR SHALL LOCATE AND VERIFY THE EXISTENCE OF ALL UTILITIES PRIOR TO STARTING WORK.
2. THE CONTRACTOR SHALL SUPPLY ALL PLANT MATERIALS IN QUANTITIES SUFFICIENT TO COMPLETE THE PLANTINGS SHOWN ON THE DRAWINGS.
3. ALL MATERIAL SHALL CONFORM TO THE GUIDELINES ESTABLISHED BY THE CURRENT AMERICAN STANDARD FOR NURSERY STOCK PUBLISHED BY THE AMERICAN ASSOCIATION OF NURSERMEN.
4. PLANTS SHALL BE SUBJECT TO INSPECTION AND APPROVAL AT THE PLACE OF GROWTH, UPON DELIVERY OR AT THE JOB SITE WHILE WORK IS ON-GOING FOR CONFORMITY TO SPECIFIED QUALITY, SIZE AND VARIETY.
5. PLANTS FURNISHED IN CONTAINERS SHALL HAVE THE ROOTS WELL ESTABLISHED IN THE SOIL MASS AND SHALL HAVE AT LEAST ONE (1) GROWING SEASON. ROOT-BOUND PLANTS OR INADEQUATELY SIZED CONTAINERS TO SUPPORT THE PLANT MAY BE DEEMED UNACCEPTABLE.
6. NO PLANT SHALL BE PUT IN THE GROUND BEFORE GRADING HAS BEEN COMPLETED.
7. ALL WORK AND PLANTS SHALL BE DONE, INSTALLED AND DETAILED IN STRICT ACCORDANCE WITH PROJECT SPECIFICATIONS.
8. ALL PLANTS SHALL BE WATERED THOROUGHLY TWICE DURING THE FIRST 24-HOUR PERIOD AFTER PLANTING. ALL PLANTS SHALL BE WATERED WEEKLY, OR MORE OFTEN IF NECESSARY, DURING THE FIRST GROWING SEASON.
9. ALL LANDSCAPE AREAS TO BE GRASS COMMON TO REGION, EXCEPT FOR INTERIOR LANDSCAPED ISLANDS OR WHERE OTHER PLANT MATERIAL IS SPECIFIED.
10. ALL TREES AND SHRUBS SHALL BE PLANTED IN MULCH BEDS WITH EDGE STRIPS TO SEPARATE TURF GRASS AREAS.
11. THE CONTRACTOR SHALL REMOVE WEEDS, ROCKS, CONSTRUCTION ITEMS, ETC. FROM ANY LANDSCAPE AREA SO DESIGNATED TO REMAIN, WHETHER ON OR OFF-SITE. GRASS SEED OR PINE BARK MULCH SHALL BE APPLIED AS DEPICTED ON PLANS.
12. EXISTING TREES TO REMAIN SHALL BE PROTECTED WITH TEMPORARY SNOW FENCING AT THE DRIPLINE OF THE TREE. THE CONTRACTOR SHALL NOT STORE VEHICLES OR MATERIALS WITHIN THE LANDSCAPED AREAS. ANY DAMAGE TO EXISTING TREES, SHRUBS OR LAWN SHALL BE REPAIRED BY THE CONTRACTOR AT NO ADDITIONAL COST TO THE OWNER.
13. ALL MULCH AREAS SHALL RECEIVE A 3" LAYER OF SHREDDED PINE BARK MULCH OVER A 10 MIL WEED MAT EQUAL TO 'WEEDBLOCK' BY EASY GARDENER OR DEWITT WEED BARRIER.
14. ALL LANDSCAPED AREAS SHALL HAVE SELECT MATERIALS REMOVED TO A DEPTH OF AT LEAST 9" BELOW FINISH GRADE. THE RESULTING VOID IS TO BE FILLED WITH A MINIMUM OF 9" HIGH-QUALITY SCREENED LOAM AMENDED WITH 3" OF AGED ORGANIC COMPOST.
15. THIS PLAN IS INTENDED FOR LANDSCAPING PURPOSES ONLY. REFER TO CIVIL/SITE DRAWINGS FOR OTHER SITE CONSTRUCTION INFORMATION.
16. IRRIGATION PIPING SYSTEM SHALL BE REVIEWED AND APPROVED BY OWNER AND ENGINEER PRIOR TO INSTALLATION.
17. WITH AUTHORIZATION OF THE PROJECT ENGINEER, PROPOSED TREES ALONG EDGE OF WOODED BUFFER SHALL BE PLACED WHEREVER NECESSARY IN ORDER TO COVER GAPS IN EXISTING WOODED BUFFER IN ORDER TO BLOCK VISIBILITY FROM TIDEWATCH CONDOMINIUM PROPERTY.
18. TREES SHALL NOT BE PLANTED ON BERMS OF STORMWATER PONDS.
19. ALL PLANTING SHALL ADHERE TO THE GENERAL REQUIREMENTS OUTLINED IN SECTION 6.3 AND THE PLANTING REQUIREMENTS OUTLINED IN SECTION 6.4 OF THE PORTSMOUTH SITE PLAN REVIEW REGULATIONS.
20. ALL PLANTING SHALL FOLLOW THE ANSI A300 PART 6 STANDARD PRACTICES FOR PLANTING AND TRANSPLANTING (AS AMENDED).

Quantity	Botanical Name	Common Name	Size
4	Calamagrostis x acutiflora 'Karl Foerster'	KARL FOERSTER REED GRASS **	2 Gallon
6	Chamaecyparis pisifera 'Mop'	MOP GOLD THREAD CYPRESS **	5 Gallon
6	Ilex glabra 'Shamrock'	SHAMROCK INKBERRY HOLLY **	5 Gallon
2	Liquidambar styraciflua	AMERICAN SWEETGUM **	3" Caliper
3	Malus x 'Robinson'	ROBINSON FLOWERING CRABAPPLE **	2" Caliper
14	Picea abies	NORWAY SPRUCE	8-9 Ft. Ht.
9	Pinus strobus	EASTERN WHITE PINE	8-9 Ft. Ht.
4	Pyrus calleryana 'Chanticleer'	CHANTICLEER CALLERY PEAR **	2.5" Caliper
4	Sedum spectabile 'Brilliant'	BRILLIANT SEDUM **	1 Gallon
2	Spiraea japonica 'Goldflame'	GOLDFLAME SPIREA **	5 Gallon
3	Syringa reticulata 'Ivory Silk'	IVORY SILK TREE LILAC	2" Caliper
38	Thuja plicata 'Green Giant'	GREEN GIANT ARBORVITAE **	7-8 Ft. Ht.
3	Tilia cordata 'Greenspire'	GREENSPIRE LITTLELEAF LINDEN **	3" Caliper
11	Tsuga canadensis	CANADIAN HEMLOCK	8-9 Ft. Ht.
2	Weigela florida 'Alexandra'	WINE & ROSES WEIGELA	5 Gallon
**	Denotes plants that are tolerant of urban conditions including road salt, soil compaction, drought, heat, and air pollution.		

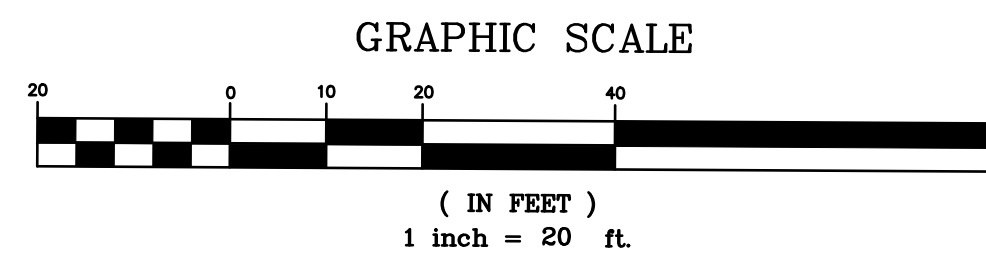

PROJECT PARCEL CITY OF PORTSMOUTH TAX MAP 222, LOT 19
TOTAL LOT AREA 84,795 SQ. FT. 1.95 ACRES

Design: DJM	Draft: KDR	Date: 2/26/2024
Checked: JAC	Scale: AS NOTED	Project No.: 18134.1
Drawing Name: 18134.1-PLAN.dwg		
THIS PLAN SHALL NOT BE MODIFIED WITHOUT WRITTEN PERMISSION FROM JONES & BEACH ENGINEERS, INC. (JBE). ANY ALTERATIONS, AUTHORIZED OR OTHERWISE, SHALL BE AT THE USER'S SOLE RISK AND WITHOUT LIABILITY TO JBE.		

REV.	DATE	REVISION	BY
1	4/19/24	REVISED PER TAC COMMENTS	DJM
0	3/18/24	ISSUED FOR REVIEW	KDR
REV.	DATE	REVISION	BY

Designed and Produced in NH

J/B Jones & Beach Engineers, Inc.

85 Portsmouth Ave. Stratham, NH 03885
 PO Box 219
 Civil Engineering Services
 603-772-4746
 E-MAIL: JBE@JONESANDBEACH.COM

Plan Name:	LANDSCAPE PLAN
Project:	LUSTER CLUSTER 635 SAGAMORE AVE., PORTSMOUTH, NH
Owner of Record:	3612 LAFAYETTE RD., DEPT 4, PORTSMOUTH, NH 03801 BK 6332 PG 1158

DRAWING No.	L1
SHEET 9 OF 20 JBE PROJECT NO. 18134.1	

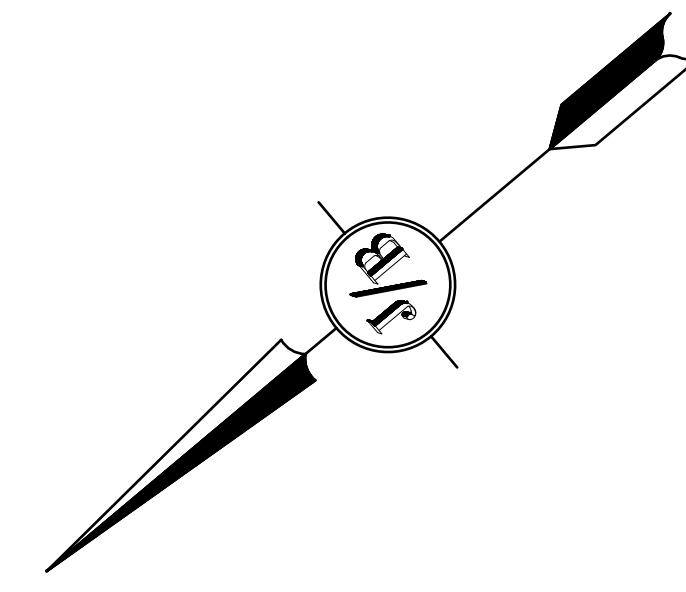

NOTES:

- THIS SITE WILL REQUIRE A USEPA NPDES PERMIT FOR STORMWATER DISCHARGE FOR THE CONSTRUCTION SITE. THE CONSTRUCTION SITE OPERATOR SHALL DEVELOP AND IMPLEMENT A CONSTRUCTION STORM WATER POLLUTION PREVENTION PLAN (SWPPP), WHICH SHALL REMAIN ON SITE AND BE MADE ACCESSIBLE TO THE PUBLIC. THE CONSTRUCTION SITE OPERATOR SHALL SUBMIT A NOTICE OF INTENT (NOI) TO THE EPA REGIONAL OFFICE SEVEN DAYS PRIOR TO COMMENCEMENT OF ANY WORK ON SITE. EPA WILL POST THE NOI AT [HTTP://CFPUB.EPA.GOV/NPDES/STORMWATER/NOI/NOISEARCH.CFM](http://cfpub.epa.gov/npdes/stormwater/NOI/NOISEARCH.CFM). AUTHORIZATION IS GRANTED UNDER THE PERMIT ONCE THE NOI IS SHOWN IN "ACTIVE" STATUS ON THIS WEBSITE. A COMPLETED NOTICE OF TERMINATION SHALL BE SUBMITTED TO THE NPDES PERMITTING AUTHORITY WITHIN 30 DAYS AFTER EITHER OF THE FOLLOWING CONDITIONS HAVE BEEN MET:
 - FINAL STABILIZATION HAS BEEN ACHIEVED ON ALL PORTIONS OF THE SITE FOR WHICH THE PERMITTEE IS RESPONSIBLE; OR
 - ANOTHER OPERATOR/PERMITTEE HAS ASSUMED CONTROL OVER ALL AREAS OF THE SITE THAT HAVE NOT BEEN FINALLY STABILIZED. PROVIDE DPW WITH A COPY OF THE NOTICE OF TERMINATION (NOT).
- ALL ROAD AND DRAINAGE WORK SHALL BE CONSTRUCTED IN ACCORDANCE WITH THE STANDARD SPECIFICATIONS FOR THE CITY, AND NHDOT SPECIFICATIONS FOR ROAD AND BRIDGE CONSTRUCTION, WHICHEVER IS MORE STRINGENT.
- AS-BUILT PLANS TO BE SUBMITTED TO THE CITY PRIOR TO ACCEPTANCE OF THE ROADWAY.
- CONTRACTOR TO COORDINATE AND COMPLETE ALL WORK REQUIRED FOR THE RELOCATION AND/OR INSTALLATION OF ELECTRIC, CATV, TELEPHONE, PER UTILITY DESIGN AND STANDARDS. LOCATIONS SHOWN ARE APPROXIMATE. LOW PROFILE STRUCTURES SHALL BE USED TO THE GREATEST EXTENT POSSIBLE.
- THIS PLAN HAS BEEN PREPARED BY JONES & BEACH ENGINEERS, INC. FOR MUNICIPAL AND STATE APPROVALS AND FOR CONSTRUCTION BASED ON DATA OBTAINED FROM ON-SITE FIELD SURVEY AND EXISTING MUNICIPAL RECORDS. THROUGHOUT THE CONSTRUCTION PROCESS, THE CONTRACTOR SHALL INFORM THE ENGINEER IMMEDIATELY OF ANY FIELD DISCREPANCY FROM DATA SHOWN ON THE DESIGN PLANS. THIS INCLUDES ANY UNFORESEEN CONDITIONS, SUBSURFACE OR OTHERWISE, FOR EVALUATION AND RECOMMENDATIONS. ANY CONTRADICTION BETWEEN ITEMS OF THIS PLAN/PLAN SET, OR BETWEEN THE PLANS AND ON-SITE CONDITIONS MUST BE RESOLVED BEFORE RELATED CONSTRUCTION HAS BEEN INITIATED.
- SILTATION AND EROSION CONTROLS SHALL BE INSTALLED PRIOR TO CONSTRUCTION, SHALL BE MAINTAINED DURING CONSTRUCTION, AND SHALL REMAIN UNTIL SITE HAS BEEN STABILIZED WITH PERMANENT VEGETATION. SEE DETAIL SHEET E1 FOR ADDITIONAL NOTES ON EROSION CONTROL.
- ALL DISTURBED AREAS NOT STABILIZED BY OCTOBER 15TH SHALL BE COVERED WITH AN EROSION CONTROL BLANKET. PRODUCT TO BE SPECIFIED BY THE ENGINEER.
- FINAL DRAINAGE, GRADING AND EROSION PROTECTION MEASURES SHALL CONFORM TO REGULATIONS OF THE PUBLIC WORKS DEPARTMENT.
- CONTRACTOR TO VERIFY EXISTING UTILITIES AND TO NOTIFY ENGINEER OF ANY DISCREPANCY IMMEDIATELY.
- DRAINAGE INSPECTION AND MAINTENANCE SCHEDULE: SILT FENCING WILL BE INSPECTED DURING AND AFTER STORM EVENTS TO ENSURE THAT THE FENCE STILL HAS INTEGRITY AND IS NOT ALLOWING SEDIMENT TO PASS. SEDIMENT BUILD UP IN SWALES WILL BE REMOVED IF IT IS DEEPER THAN SIX INCHES, AND IS TO BE REMOVED FROM SUMPS BELOW THE INLET OF CULVERTS SEMIANNUALLY, AS WELL AS FROM CATCH BASINS. FOLLOWING MAJOR STORM EVENTS, THE STAGE DISCHARGE OUTLET STRUCTURES ARE TO BE INSPECTED AND ANY DEBRIS REMOVED FROM THE ORIFICE, TRASH TRACK AND EMERGENCY SPILL WAY. INFREQUENTLY, SEDIMENT MAY ALSO HAVE TO BE REMOVED FROM THE SUMP OF THE STRUCTURE.
- ALL DRAINAGE INFRASTRUCTURE SHALL BE INSTALLED AND STABILIZED PRIOR TO DIRECTING ANY RUNOFF TO IT.
- BIORETENTION PONDS REQUIRE TIMELY MAINTENANCE AND SHOULD BE INSPECTED AFTER EVERY MAJOR STORM EVENT, AS WELL AS FREQUENTLY DURING THE FIRST YEAR OF OPERATION, AND ANNUALLY THEREAFTER. EVERY FIVE YEARS, THE SERVICES OF A PROFESSIONAL ENGINEER SHOULD BE RETAINED TO PERFORM A THOROUGH INSPECTION OF THE BIORETENTION POND AND ITS INFRASTRUCTURE. ANY DEBRIS AND SEDIMENT ACCUMULATIONS SHOULD BE REMOVED FROM THE OUTLET STRUCTURE(S) AND EMERGENCY SPILLWAY(S) AND DISPOSED OF PROPERLY. BIORETENTION POND BERMS SHOULD BE MOWED AT LEAST ONCE ANNUALLY SO AS TO PREVENT THE ESTABLISHMENT OF WOODY VEGETATION. TREES SHOULD NEVER BE ALLOWED TO GROW ON A BIORETENTION POND BERM, AS THEY MAY DESTABILIZE THE STRUCTURE AND INCREASE THE POTENTIAL FOR FAILURE. AREAS SHOWING SIGNS OF EROSION OR THIN OR DYING VEGETATION SHOULD BE REPAIRED IMMEDIATELY BY WHATEVER MEANS NECESSARY, WITH THE EXCEPTION OF FERTILIZER. RODENT BORROWS SHOULD BE REPAIRED IMMEDIATELY AND THE ANIMALS SHOULD BE TRAPPED AND RELOCATED IF THE PROBLEM PERSISTS.
- IN THOSE AREAS WHERE THE BERMS OF THE BIORETENTION SYSTEMS MUST BE CONSTRUCTED BY THE PLACEMENT OF FILL, THE ENTIRE EMBANKMENT AREA OF THE BIORETENTION PONDS SHALL BE EXCAVATED TO PROPOSED GRADE, STRIPPED OF ALL ORGANIC MATERIAL, COMPACTED TO AT LEAST 95% AND SCARIFIED PRIOR TO THE PLACEMENT OF THE EMBANKMENT MATERIAL. IN THE EVENT THE FOUNDATION MATERIAL EXPOSED DOES NOT ALLOW THE SPECIFIED COMPACTION, AN ADDITIONAL ONE FOOT (1') OF EXCAVATION AND THE PLACEMENT OF A ONE FOOT (1') THICK, TWELVE FOOT (12') WIDE PAD OF THE MATERIAL DESCRIBED IN THE NOTE BELOW, COMPACTED TO 95% OF ASTM D-1557 MAY BE NECESSARY. PLACEMENT AND COMPACTION SHOULD OCCUR AT A MOISTURE CONTENT OF OPTIMUM PLUS OR MINUS 3%, AND NO FROZEN OR ORGANIC MATERIAL SHOULD BE PLACED WITHIN FOR ANY REASON.
- EMBANKMENT IS TO HAVE 3:1 SIDE SLOPES (MAX.) AND IS TO BE BROUGHT TO SPECIFIED GRADES PRIOR TO THE ADDITION OF LOAM (4" MINIMUM) SO AS TO ALLOW FOR THE COMPACTION OF THE STRUCTURE OVER TIME WHILE MAINTAINING THE PROPER BERM ELEVATION.
- COMPACTION TESTING SERVICES (I.E. NUCLEAR DENSITY TESTS) ARE TO BE PERFORMED BY AN INDEPENDENT GEOTECHNICAL ENGINEER RETAINED BY THE CONTRACTOR FOR ROADWAY CONSTRUCTION, AND ON THE FOUNDATION OF THE BERM AND ON EVERY LIFT OF NEWLY PLACED MATERIAL.

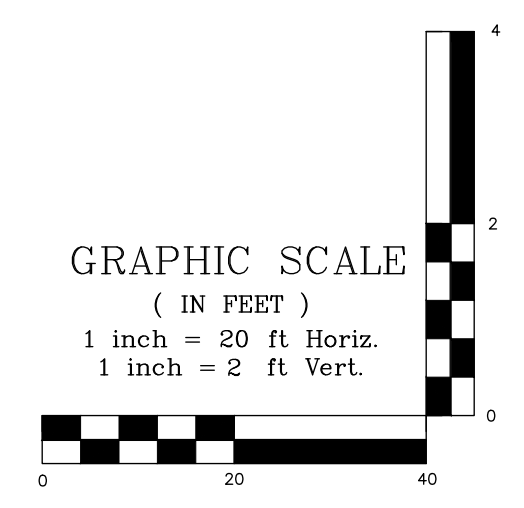
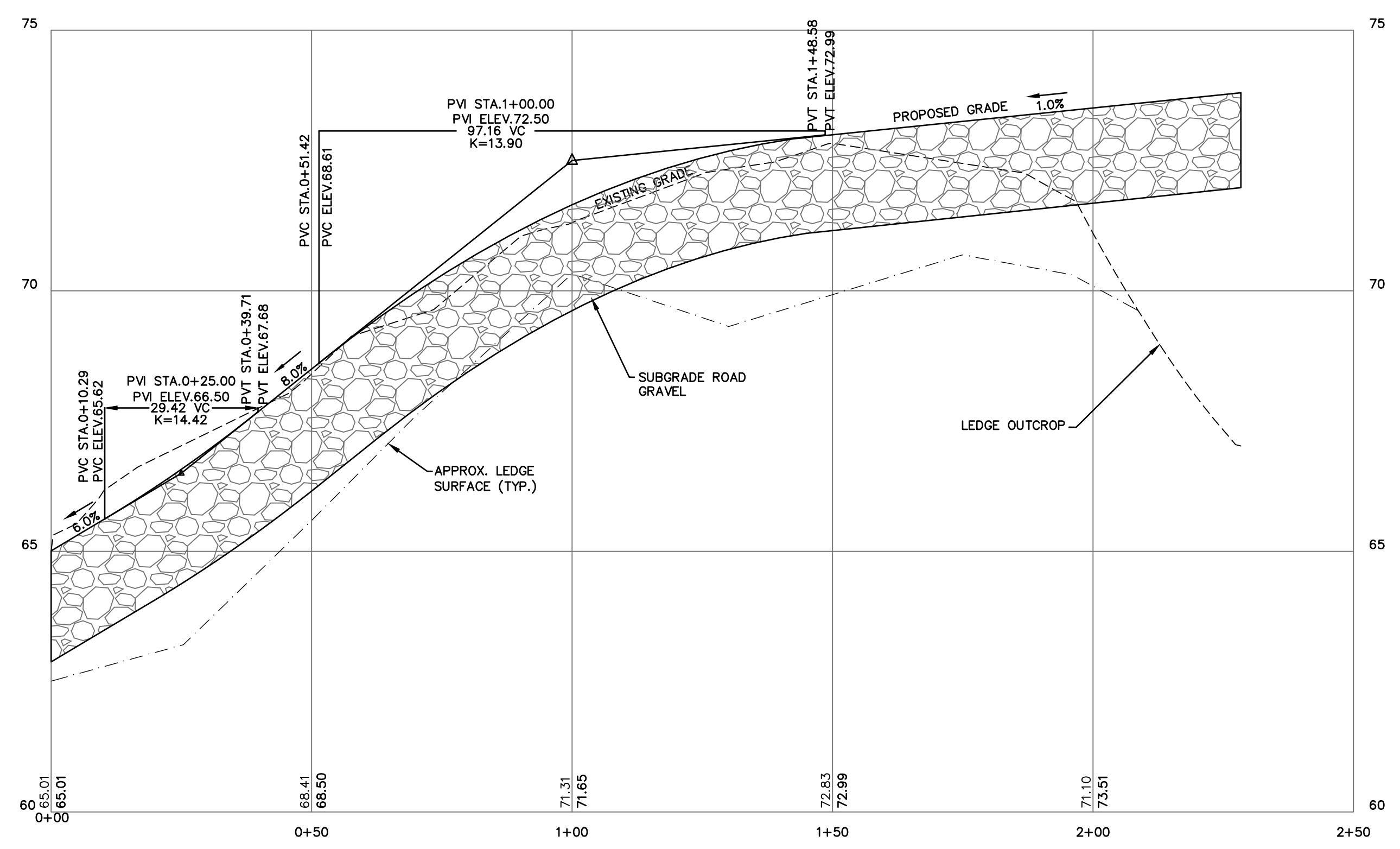

Design: DJM Draft: KDR Date: 2/26/2024
 Checked: JAC Scale: AS NOTED Project No.: 18134.1
 Drawing Name: 18134.1-PLAN.dwg
 THIS PLAN SHALL NOT BE MODIFIED WITHOUT WRITTEN PERMISSION FROM JONES & BEACH ENGINEERS, INC. (JBE). ANY ALTERATIONS, AUTHORIZED OR OTHERWISE, SHALL BE AT THE USER'S SOLE RISK AND WITHOUT LIABILITY TO JBE.

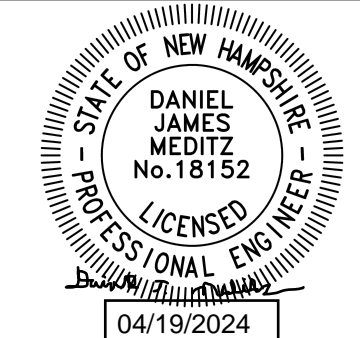

REV.	DATE	REVISION	BY
1	4/19/24	REVISED PER TAC COMMENTS	DJM
0	3/18/24	ISSUED FOR REVIEW	KDR
		REVISION	BY

Designed and Produced in NH

J/B Jones & Beach Engineers, Inc.

85 Portsmouth Ave. Civil Engineering Services 603-772-4746
 PO Box 219 Stratham, NH 03885 FAX: 603-772-0227
 E-MAIL: JBE@JONESANDBEACH.COM

Plan Name: **DRIVEWAY PLAN AND PROFILE**

Project: **LUSTER CLUSTER
635 SAGAMORE AVE., PORTSMOUTH, NH**

Owner of Record: 3612 LAFAYETTE RD., DEPT 4, PORTSMOUTH, NH 03801 BK 6332 PG 1158

DRAWING No. **P1**

SHEET 10 OF 20
 JBE PROJECT NO. 18134.1

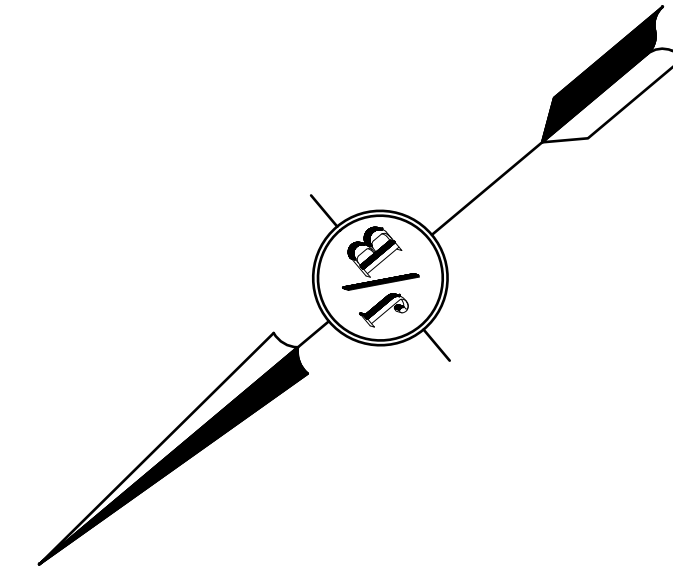
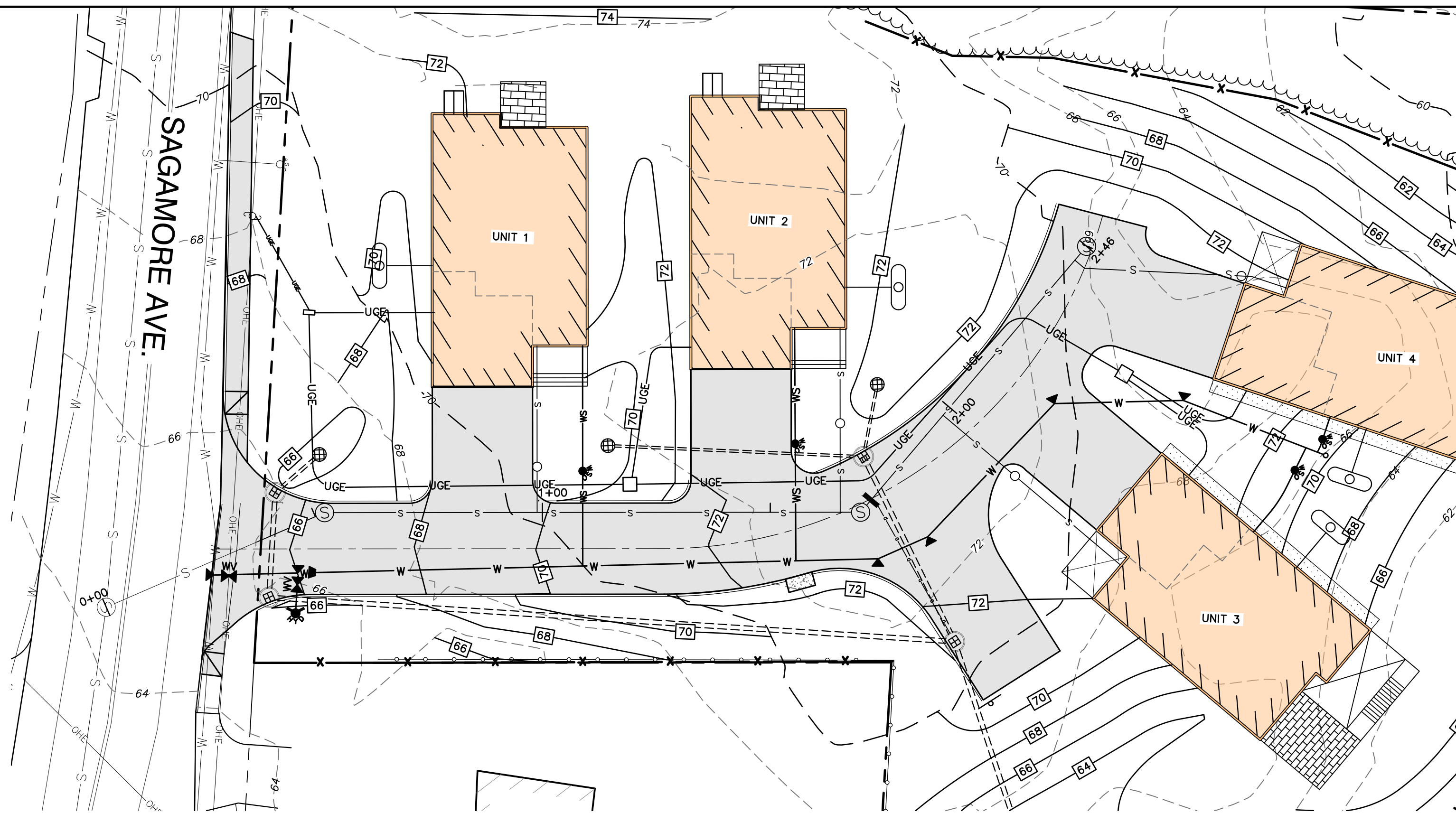

NOTES:

1. PROPOSED GRADES SHOWN HEREON ARE APPROXIMATE. REFER TO SHEETS C3 AND P1 FOR GRADING OF SITE AND DRIVEWAY. SET RIM ELEVATIONS OF SEWER STRUCTURES FLUSH WITH PROPOSED GRADE.
2. STATIONS REFER TO CENTERLINE OF SEWER STRUCTURE OR CROSSING DRAINAGE/WATER PIPE.
3. CONTRACTOR TO CONFIRM ACTUAL EXISTING INVERT OF STUB IN THE FIELD AND NOTIFY ENGINEER IF IT IS MORE THAN 0.1' DIFFERENT FROM THE STATED INVERT.

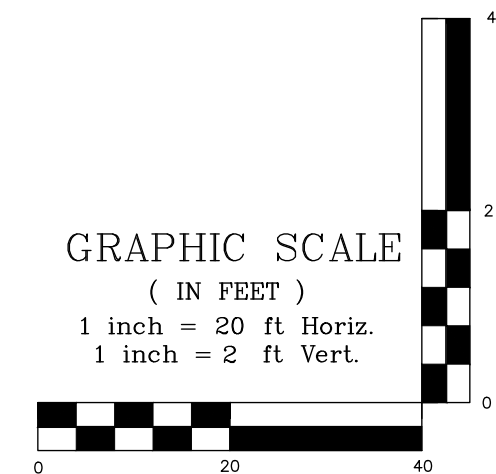
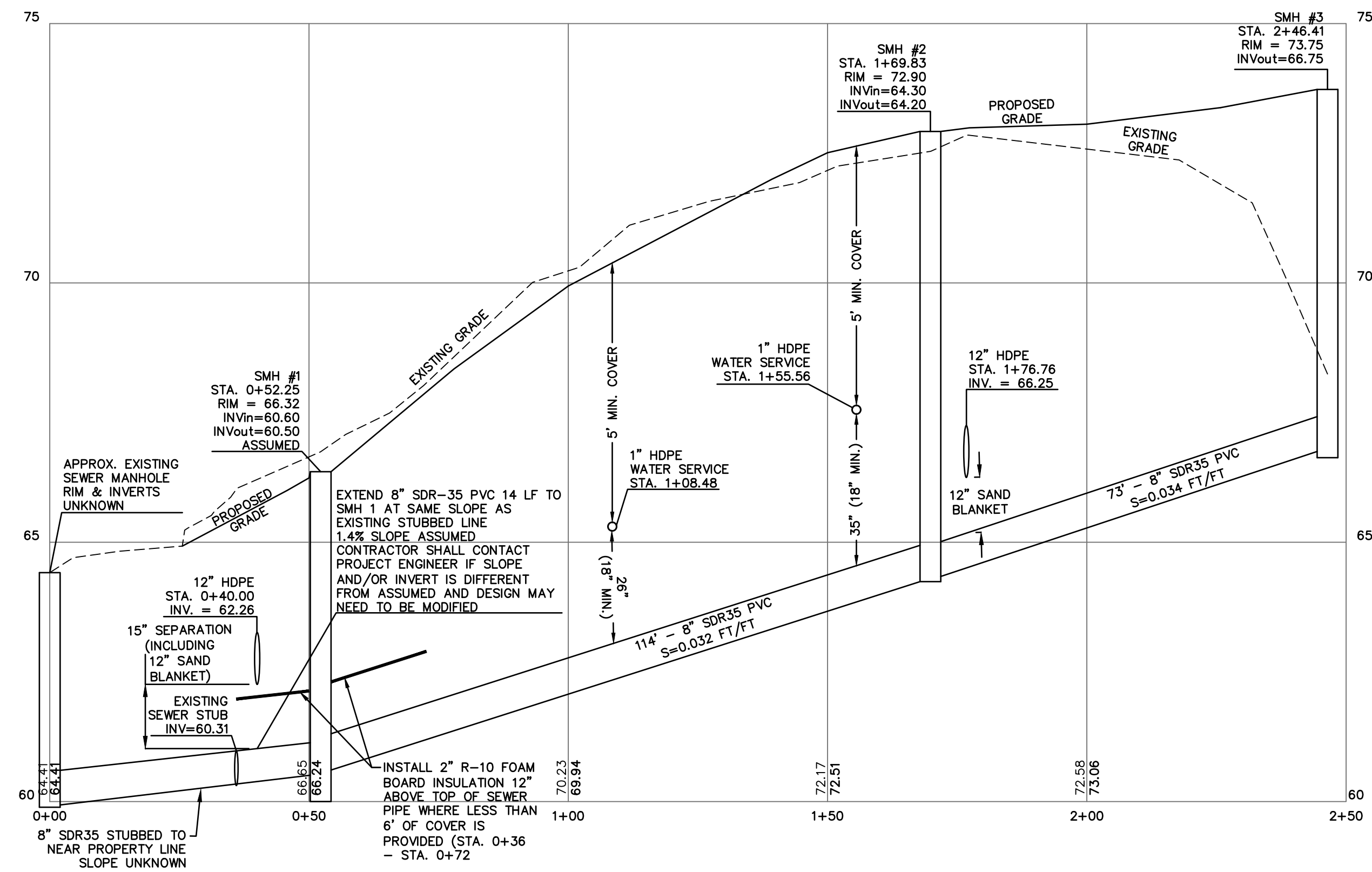

Design: DJM Draft: KDR Date: 2/26/2024
Checked: JAC Scale: AS NOTED Project No.: 18134.1
Drawing Name: 18134.1-PLAN.dwg
THIS PLAN SHALL NOT BE MODIFIED WITHOUT WRITTEN PERMISSION FROM JONES & BEACH ENGINEERS, INC. (JBE). ANY ALTERATIONS, AUTHORIZED OR OTHERWISE, SHALL BE AT THE USER'S SOLE RISK AND WITHOUT LIABILITY TO JBE.

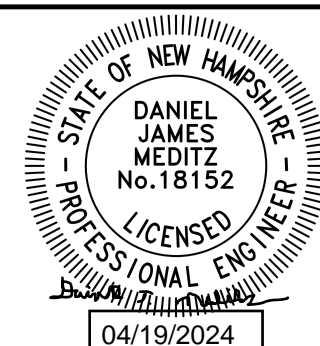

REV.	DATE	REVISION	BY
1	4/19/24	REVISED PER TAC COMMENTS	DJM
0	3/18/24	ISSUED FOR REVIEW	KDR
		REVISION	BY

Designed and Produced in NH

J/B Jones & Beach Engineers, Inc.

85 Portsmouth Ave. Stratham, NH 03885
Civil Engineering Services
603-772-4746
PO Box 219 FAX: 603-772-0227
E-MAIL: JBE@JONESANDBEACH.COM

Plan Name: **SEWER PLAN AND PROFILE**

Project: **LUSTER CLUSTER
635 SAGAMORE AVE., PORTSMOUTH, NH**

Owner of Record: 3612 LAFAYETTE RD., DEPT 4, PORTSMOUTH, NH 03801 BK 6332 PG 1158

DRAWING No. **P2**

SHEET 11 OF 20
JBE PROJECT NO. 18134.1

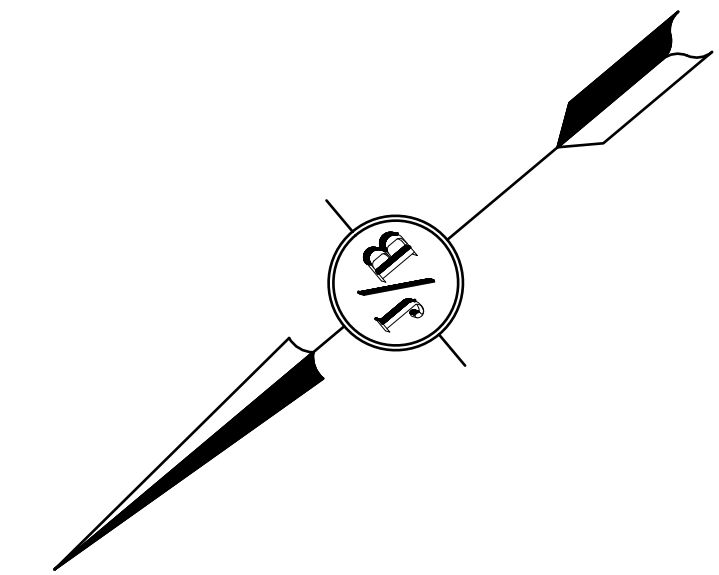
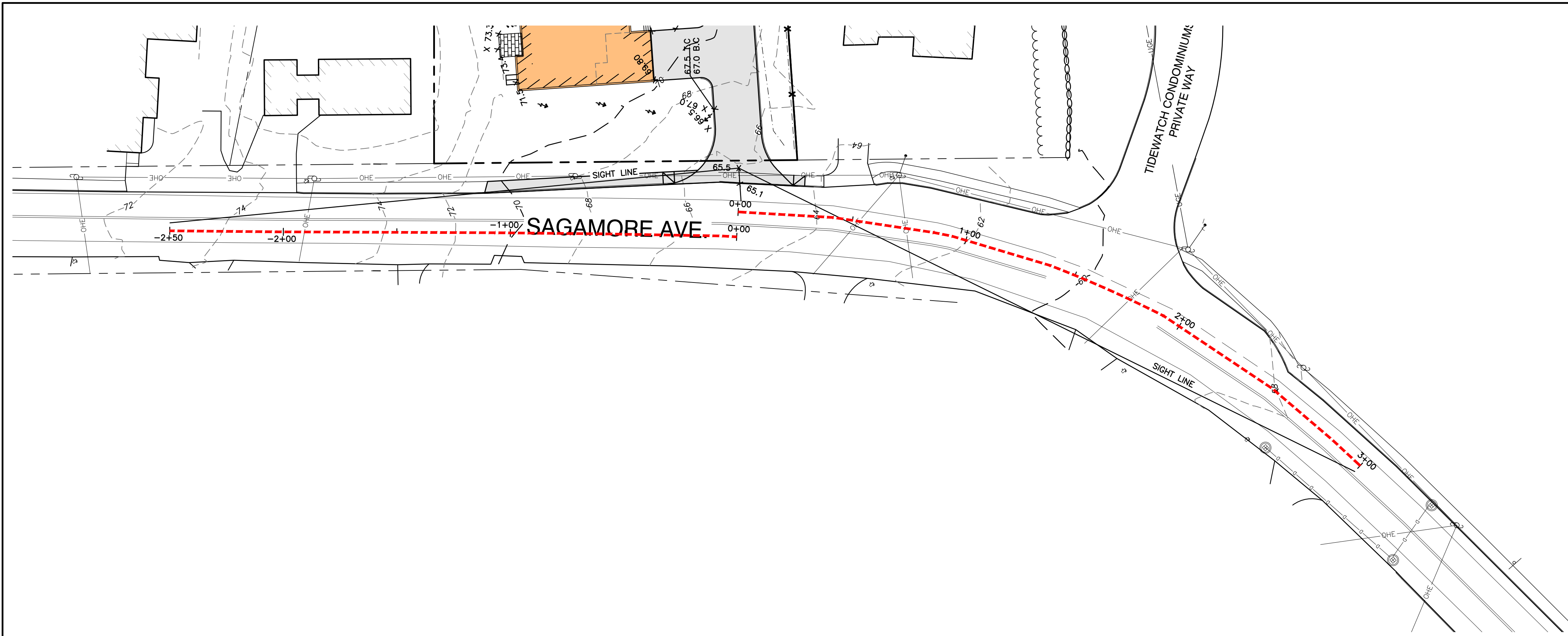

$$S = 1.47V(2.5) + \frac{V^2}{30 \left[0.347826 \pm \left(\frac{G}{100} \right) \right]}$$

Where:
 S = Stopping sight distance on grade (ft)
 V = Design speed (mph)
 G = Grade (%)

Stopping Sight Distance on Grades
 Exhibit 1260-3

PER AASHTO POLICY ON GEOMETRIC DESIGN OF HIGHWAYS AND STREETS:

NORTHBOUND APPROACH
 DESIGN SPEED: 33 MPH
 AVERAGE ROAD GRADE OVER FIRST 100 FEET: -5.2% (5.2' DROP OVER 100 FEET)
 REQUIRED SIGHT DISTANCE:
 $1.47(33)(2.5) + ((33)^2 / (30 * (0.347826 - (5.2/100)))) = 244'$ SIGHT DISTANCE REQUIRED

SOUTHBOUND APPROACH
 DESIGN SPEED: 33 MPH
 AVERAGE ROAD GRADE OVER FIRST 100 FEET: 3.3% (3.3' GAIN OVER 100 FEET)
 REQUIRED SIGHT DISTANCE:
 $1.47(33)(2.5) + ((33)^2 / (30 * (0.347826 + (3.3/100)))) = 216'$ SIGHT DISTANCE REQUIRED

PORTSMOUTH SITE PLAN REVIEW REGULATIONS SECTION 3.3.2.1

ACCESSWAYS AND DRIVEWAYS SHALL, WHERE PRACTICAL, HAVE AN ALL-SEASON SAFE SIGHT DISTANCE (ACCORDING TO AASHTO STANDARDS) IN BOTH DIRECTIONS ALONG THE PUBLIC STREET. WHERE ONLY A LESSER SIGHT DISTANCE IS OBTAINABLE, NO MORE THAN ONE ACCESSWAY PER SINGLE PARCEL SHALL BE ALLOWED.

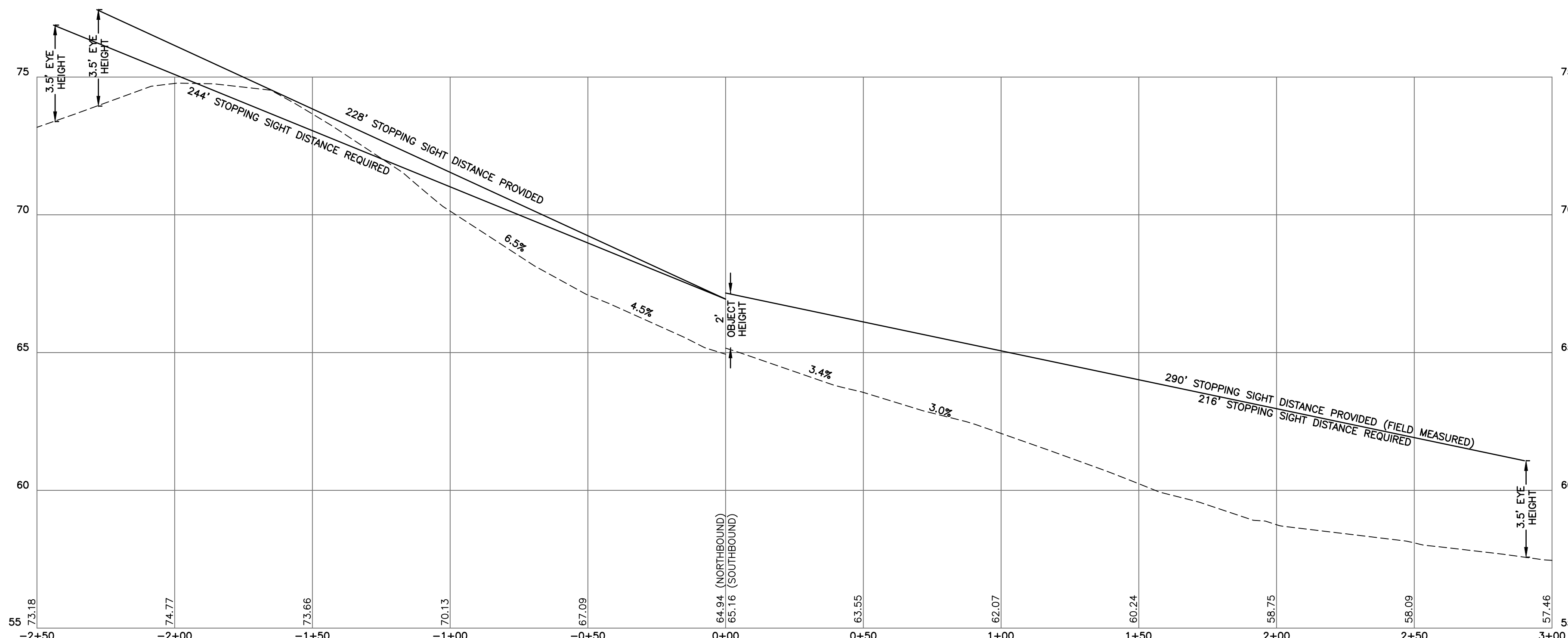

STOPPING SIGHT DISTANCE PLAN & PROFILE

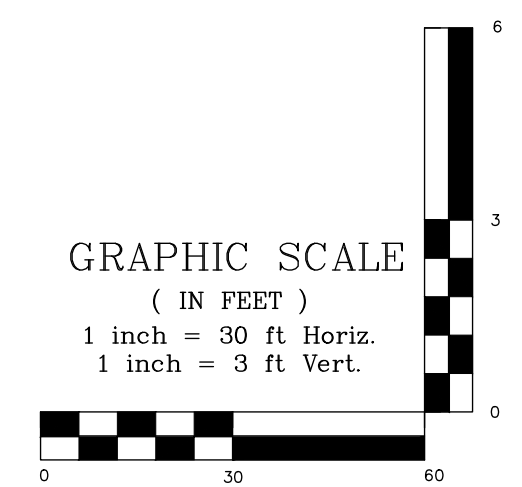

Design: DJM Draft: KDR Date: 2/26/2024
 Checked: JAC Scale: AS NOTED Project No.: 18134.1
 Drawing Name: 18134.1-PLAN.dwg
 THIS PLAN SHALL NOT BE MODIFIED WITHOUT WRITTEN PERMISSION FROM JONES & BEACH ENGINEERS, INC. (JBE). ANY ALTERATIONS, AUTHORIZED OR OTHERWISE, SHALL BE AT THE USER'S SOLE RISK AND WITHOUT LIABILITY TO JBE.

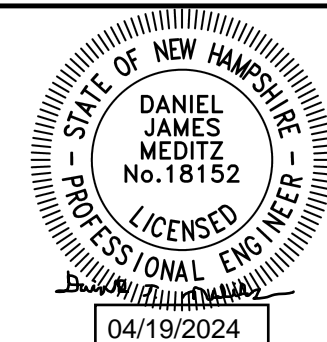

REV.	DATE	REVISION	BY
1	4/19/24	REVISED PER TAC COMMENTS	DJM
0	3/18/24	ISSUED FOR REVIEW	KDR

Designed and Produced in NH

J/B Jones & Beach Engineers, Inc.
 Civil Engineering Services

85 Portsmouth Ave. PO Box 219 Stratham, NH 03885
 603-772-4746 FAX: 603-772-0227 E-MAIL: JBE@JONESANDBEACH.COM

Plan Name:	HIGHWAY ACCESS PLAN
Project:	LUSTER CLUSTER 635 SAGAMORE AVE., PORTSMOUTH, NH
Owner of Record:	635 SAGAMORE DEVELOPMENT LLC 3612 LAFAYETTE RD., DEPT 4, PORTSMOUTH, NH 03801 BK 6332 PG 1158

DRAWING No.
H1
 SHEET 12 OF 20
 JBE PROJECT NO. 18134.1

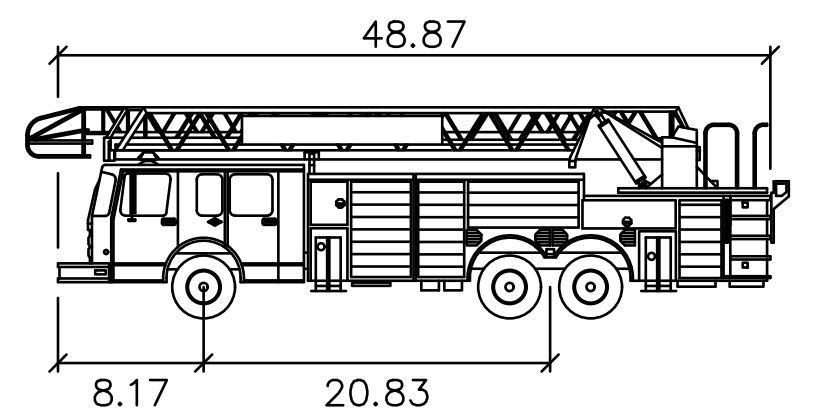
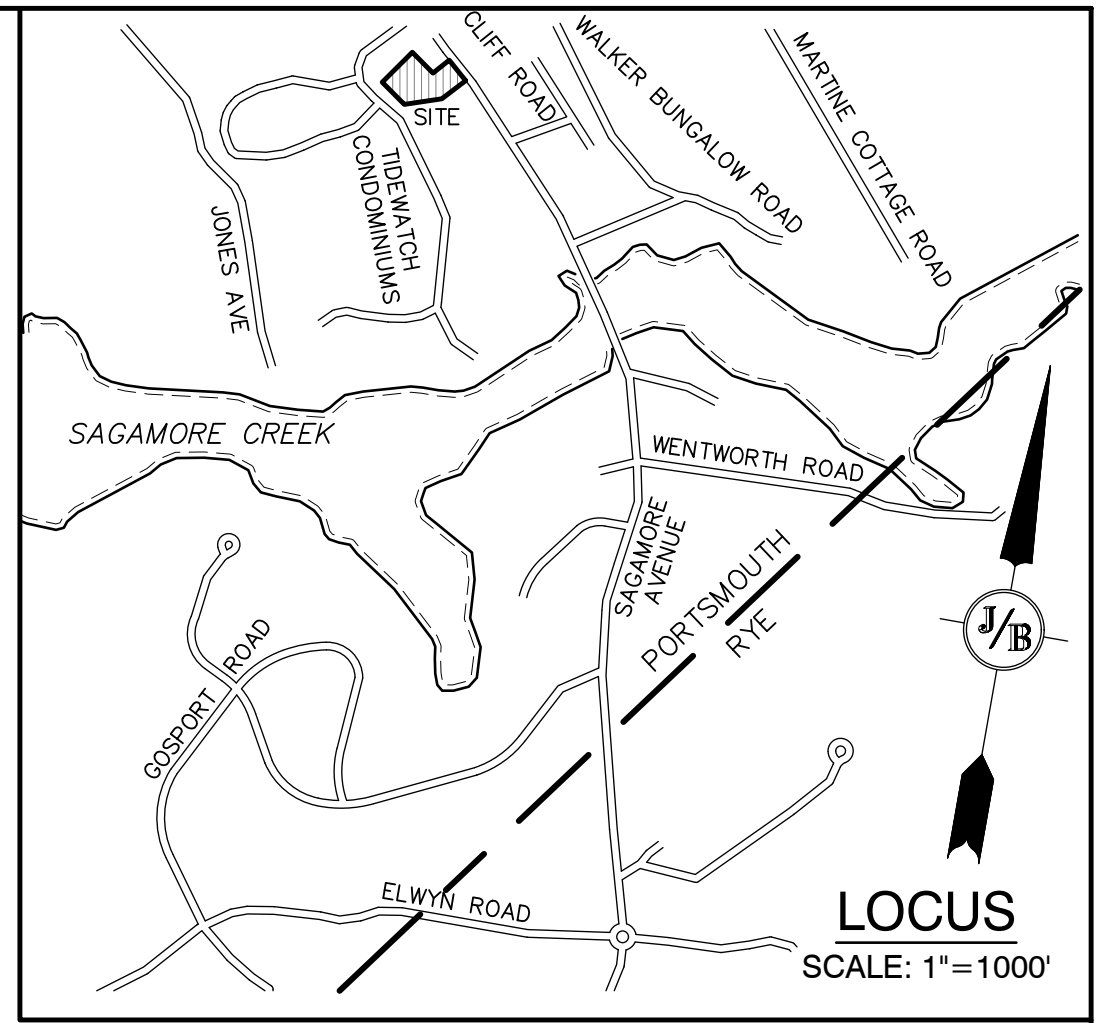
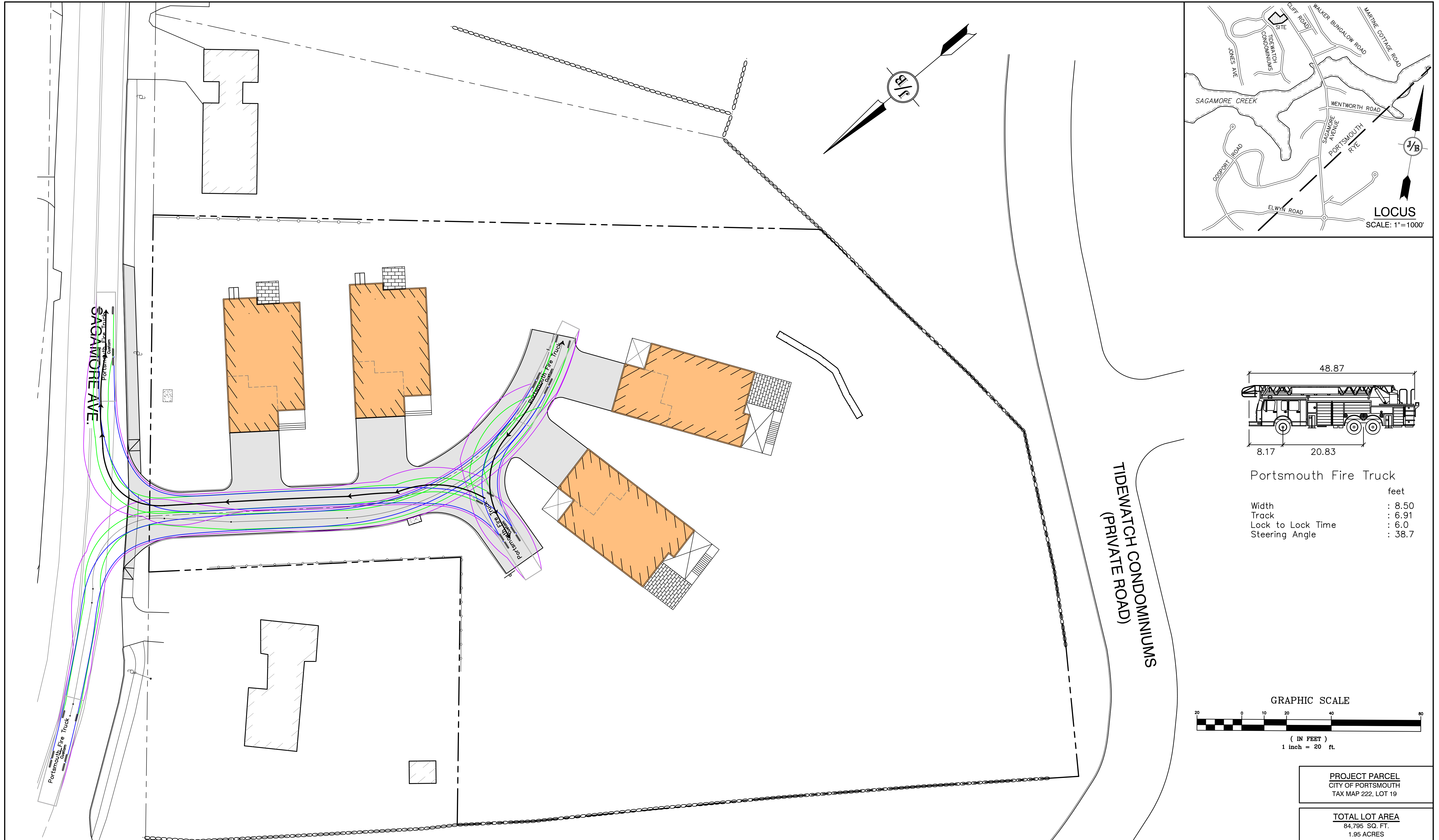

Portsmouth Fire Truck

	feet
Width	: 8.50
Track	: 6.91
Lock to Lock Time	: 6.0
Steering Angle	: 38.7

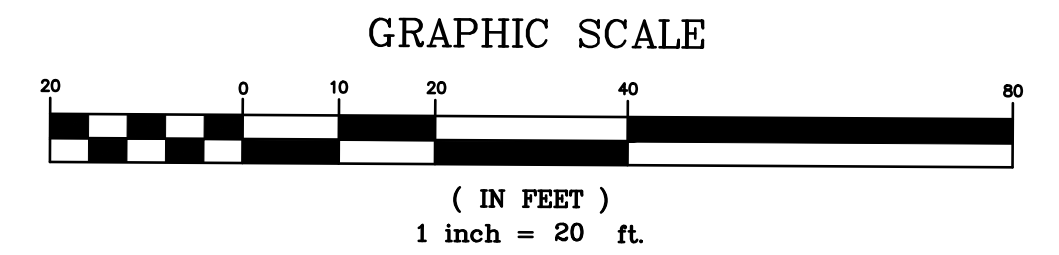

PROJECT PARCEL CITY OF PORTSMOUTH TAX MAP 222, LOT 19
TOTAL LOT AREA 84,795 SQ. FT. 1.95 ACRES

Design: DJM Draft: KDR Date: 2/26/2024
 Checked: JAC Scale: AS NOTED Project No.: 18134.1
 Drawing Name: 18134.1-PLAN.dwg
 THIS PLAN SHALL NOT BE MODIFIED WITHOUT WRITTEN PERMISSION FROM JONES & BEACH ENGINEERS, INC. (JBE). ANY ALTERATIONS, AUTHORIZED OR OTHERWISE, SHALL BE AT THE USER'S SOLE RISK AND WITHOUT LIABILITY TO JBE.

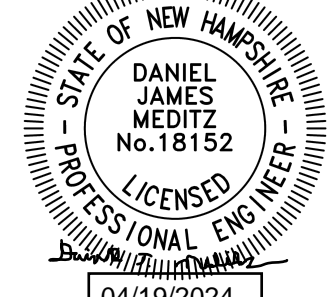

REV.	DATE	REVISION	BY
1	4/19/24	REVISED PER TAC COMMENTS	DJM
0	3/18/24	ISSUED FOR REVIEW	KDR

Designed and Produced in NH

J/B Jones & Beach Engineers, Inc.

85 Portsmouth Ave. Civil Engineering Services 603-772-4746
 PO Box 219 Stratham, NH 03885 FAX: 603-772-0227
 E-MAIL: JBE@JONESANDBEACH.COM

Plan Name:	TRUCK TURNING PLAN
Project:	LUSTER CLUSTER 635 SAGAMORE AVE., PORTSMOUTH, NH
Owner of Record:	3612 LAFAYETTE RD., DEPT 4, PORTSMOUTH, NH 03801 BK 6332 PG 1158

DRAWING No.
T1
 SHEET 13 OF 20
 JBE PROJECT NO. 18134.1

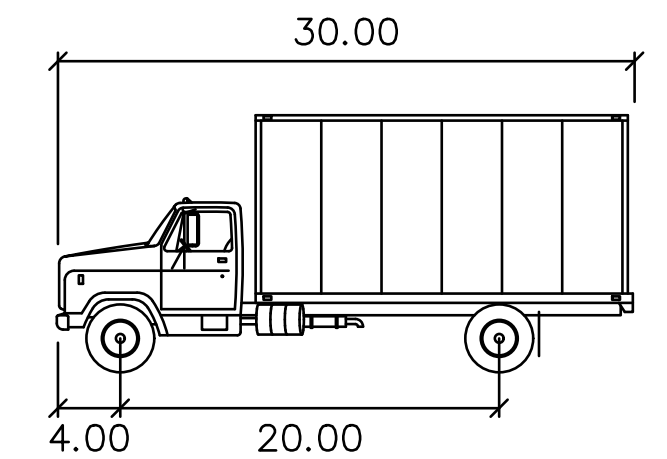
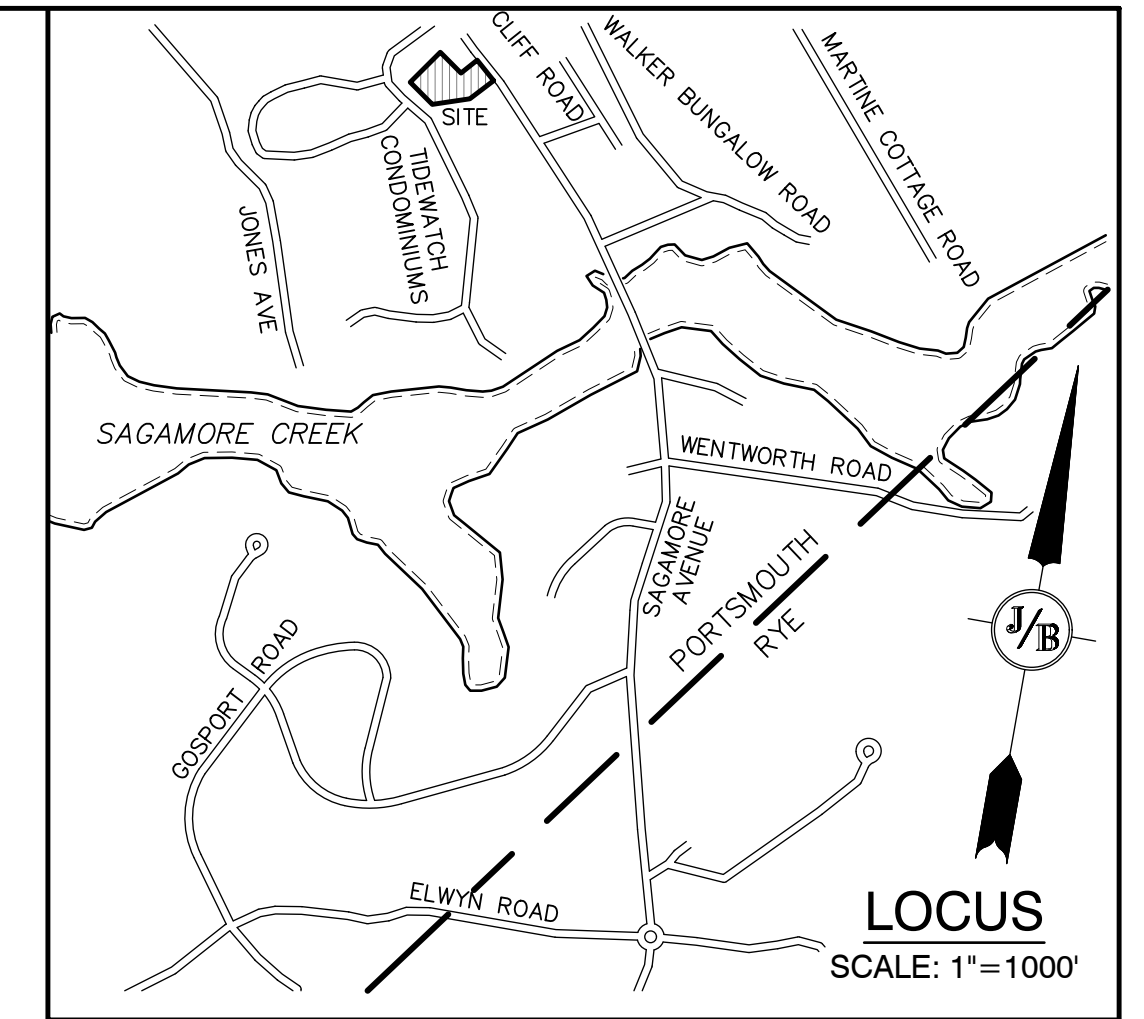
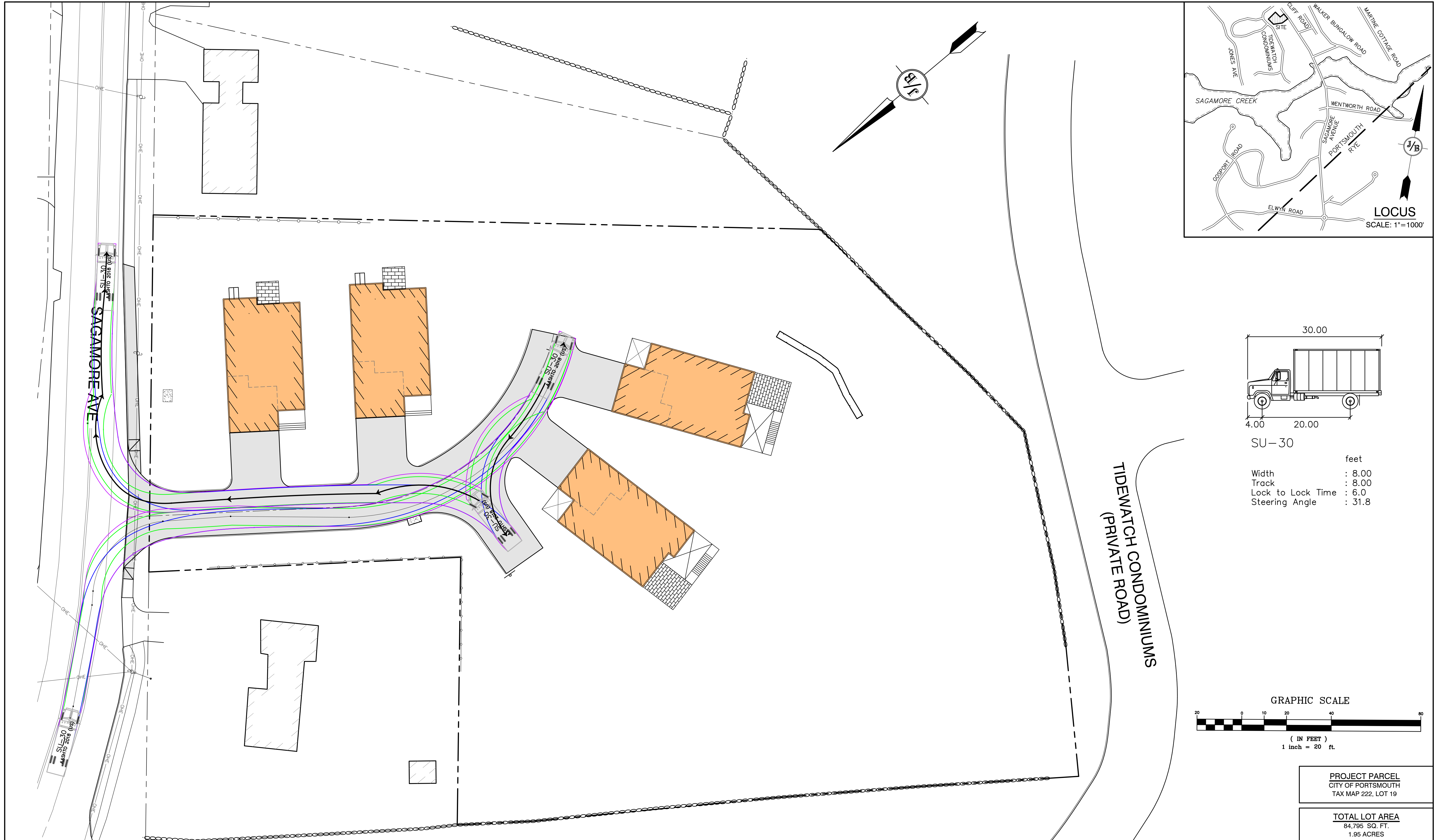

SU-30

feet

Width : 8.00

Track : 8.00

Lock to Lock Time : 6.0

Steering Angle : 31.8

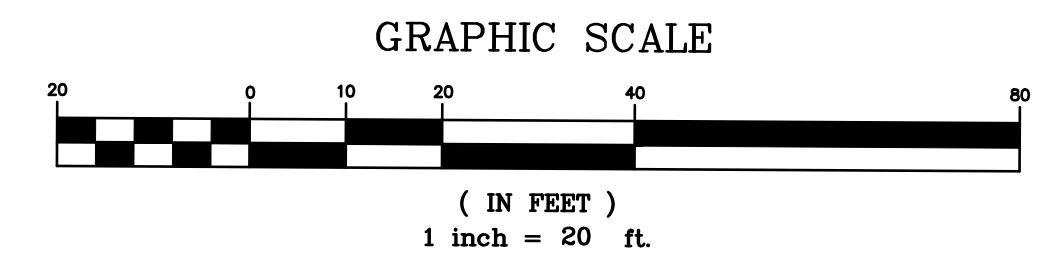

PROJECT PARCEL CITY OF PORTSMOUTH TAX MAP 222, LOT 19
TOTAL LOT AREA 84,795 SQ. FT. 1.95 ACRES

Design: DJM Draft: KDR Date: 2/26/2024
 Checked: JAC Scale: AS NOTED Project No.: 18134.1
 Drawing Name: 18134.1-PLAN.dwg

THIS PLAN SHALL NOT BE MODIFIED WITHOUT WRITTEN PERMISSION FROM JONES & BEACH ENGINEERS, INC. (JBE). ANY ALTERATIONS, AUTHORIZED OR OTHERWISE, SHALL BE AT THE USER'S SOLE RISK AND WITHOUT LIABILITY TO JBE.

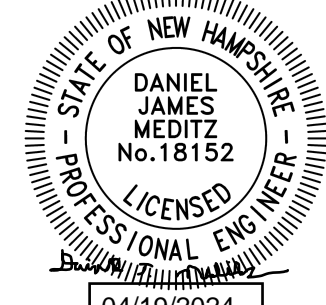

REV.	DATE	REVISION	BY
1	4/19/24	REVISED PER TAC COMMENTS	DJM
0	3/18/24	ISSUED FOR REVIEW	KDR

Designed and Produced in NH

J/B Jones & Beach Engineers, Inc.

85 Portsmouth Ave. Civil Engineering Services 603-772-4746
 PO Box 219 Stratham, NH 03885 FAX: 603-772-0227
 E-MAIL: JBE@JONESANDBEACH.COM

Plan Name:	TRUCK TURNING PLAN
Project:	LUSTER CLUSTER 635 SAGAMORE AVE., PORTSMOUTH, NH
Owner of Record:	3612 LAFAYETTE RD., DEPT 4, PORTSMOUTH, NH 03801 BK 6332 PG 1158

DRAWING No.

T2

SHEET 14 OF 20
JBE PROJECT NO. 18134.1

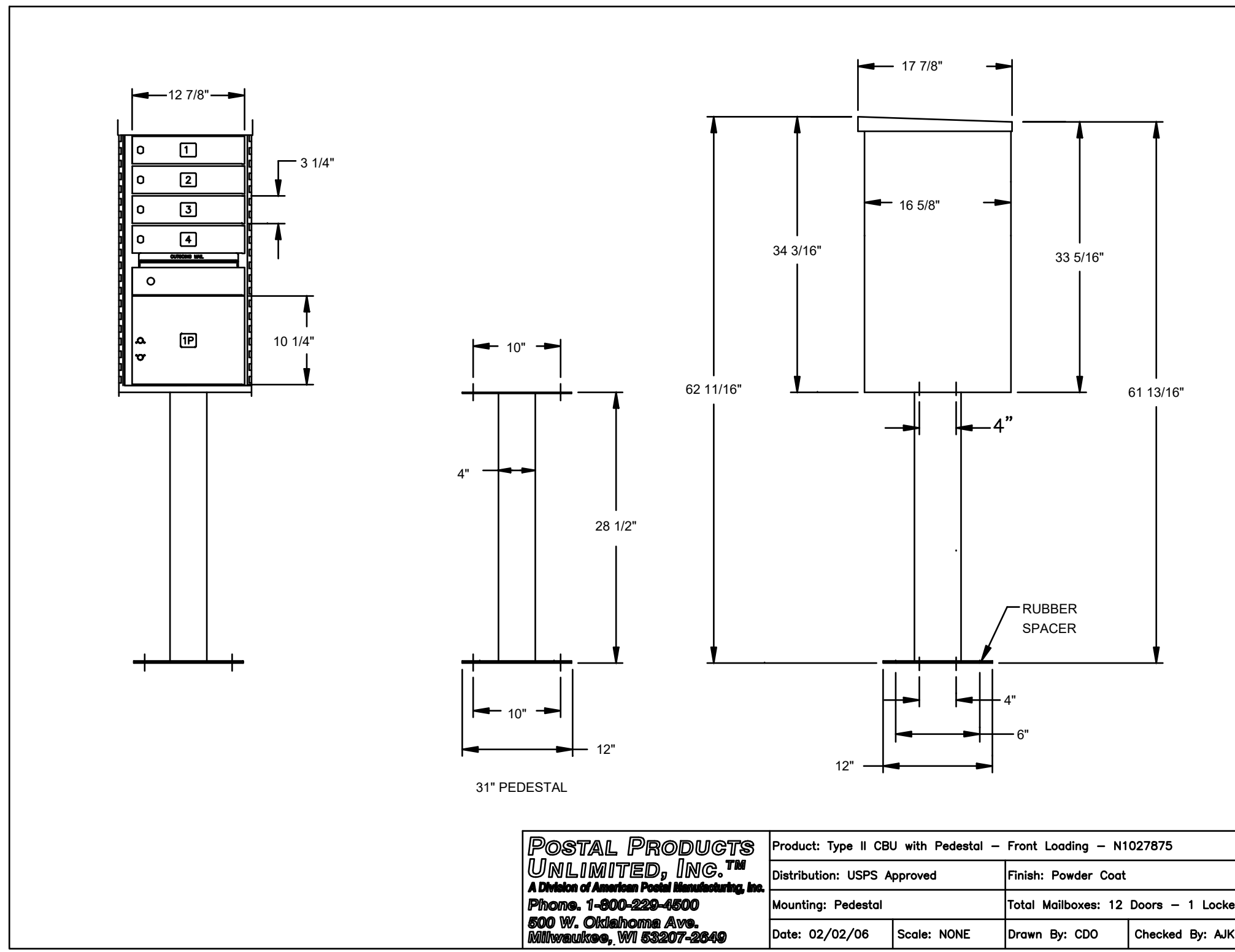

CLUSTER MAILBOX UNIT DETAIL

NOT TO SCALE

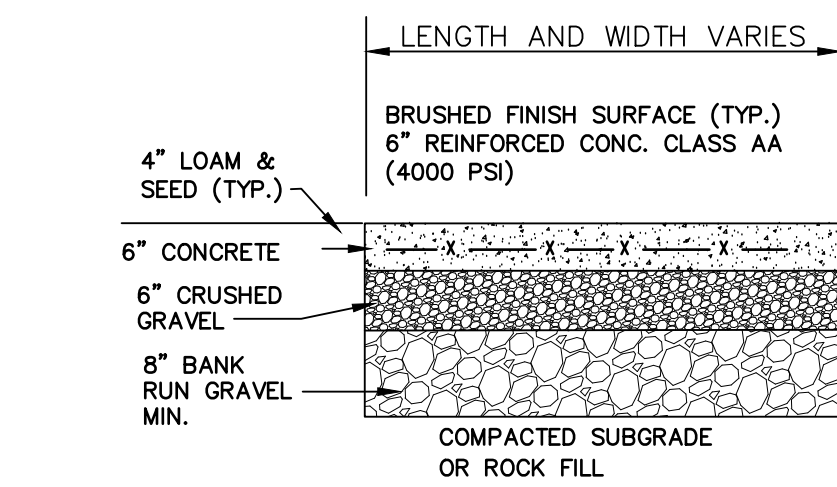

CONCRETE PAD DETAIL

NOT TO SCALE

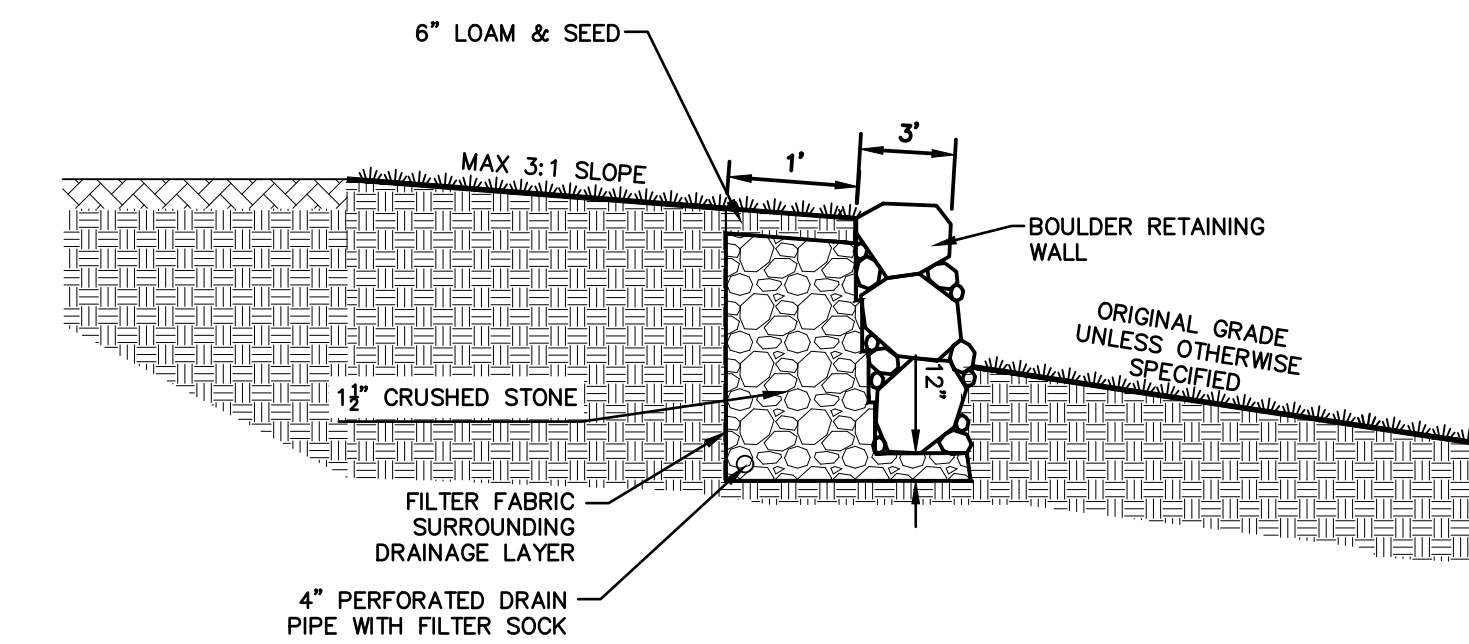

THE CONTRACTOR IS RESPONSIBLE FOR RETAINING THE SERVICES OF A STRUCTURAL ENGINEER LICENSED IN THE STATE OF NEW HAMPSHIRE TO DESIGN ANY WALL THAT HAS A HEIGHT OVER 4.0'. JONES & BEACH ENGINEERS, INC. DOES NOT ACCEPT ANY LIABILITY FOR THE STRUCTURAL DESIGN AND/OR INSTALLATION OF ANY RETAINING WALL OF ANY TYPE ABOVE THIS HEIGHT. THIS DETAIL IS INTENDED TO PROVIDE AN EXAMPLE OF THE RETAINING WALL FOR PLANNING PURPOSES ONLY AND IS SPECIFICALLY NOT INTENDED FOR USE BY THE CONTRACTOR IN ANY CONSTRUCTION-RELATED ACTIVITY FOR A WALL GREATER THAN 4.0' IN HEIGHT.

BOULDER RETAINING WALL CROSS SECTION

NOT TO SCALE

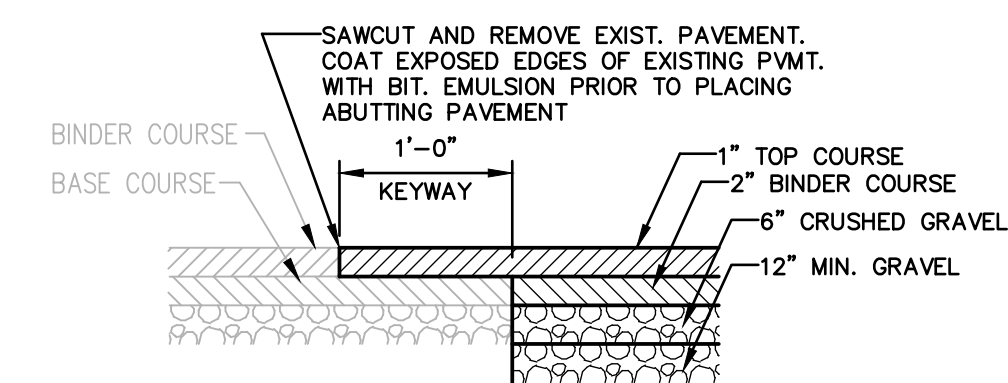

KEYWAY DETAIL FOR CONNECTION TO EXISTING PAVEMENT

NOT TO SCALE

CONCRETE PAD DETAIL

NOT TO SCALE

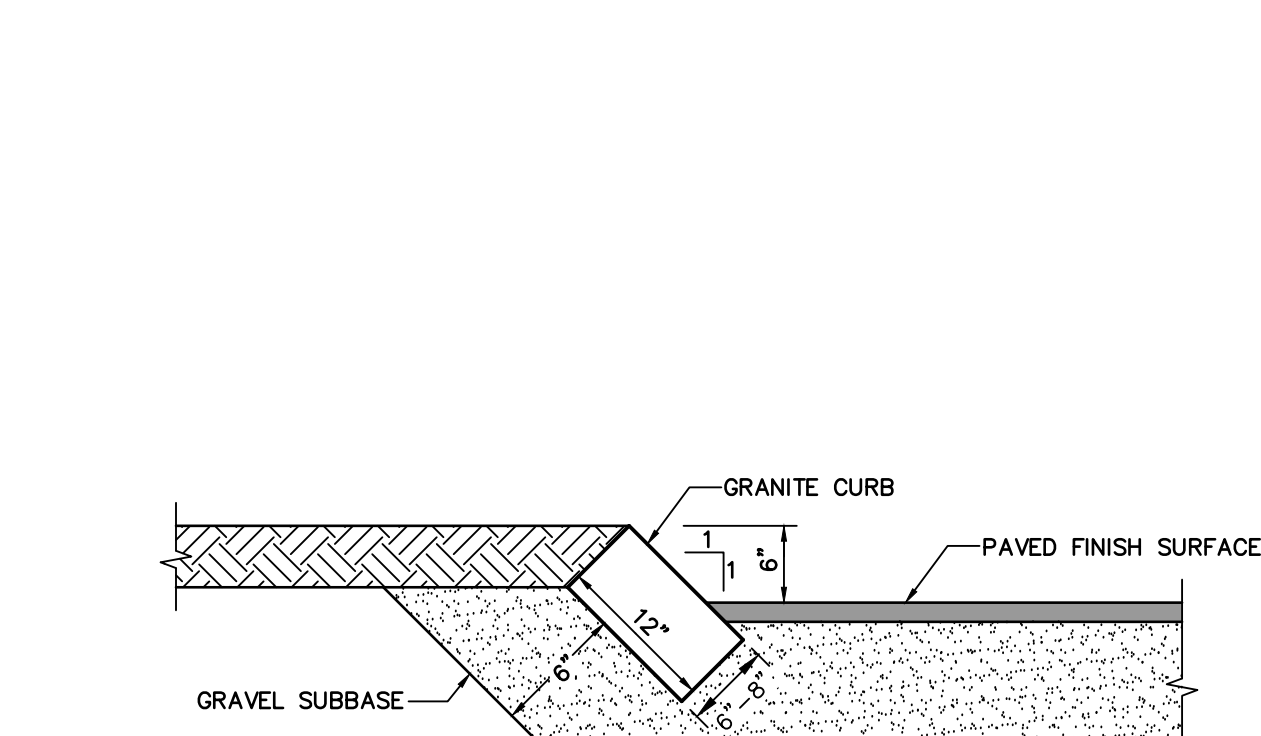

- NOTES:**
1. EDGING TO BE PLACED PRIOR TO PLACING TOP SURFACE COURSE.
 2. JOINTS BETWEEN STONES SHALL BE MORTARED.
 3. SALVAGE GRANITE CURBS ON-SITE AND RESET TO THE EXTENT POSSIBLE.

SLOPED GRANITE CURB

NOT TO SCALE

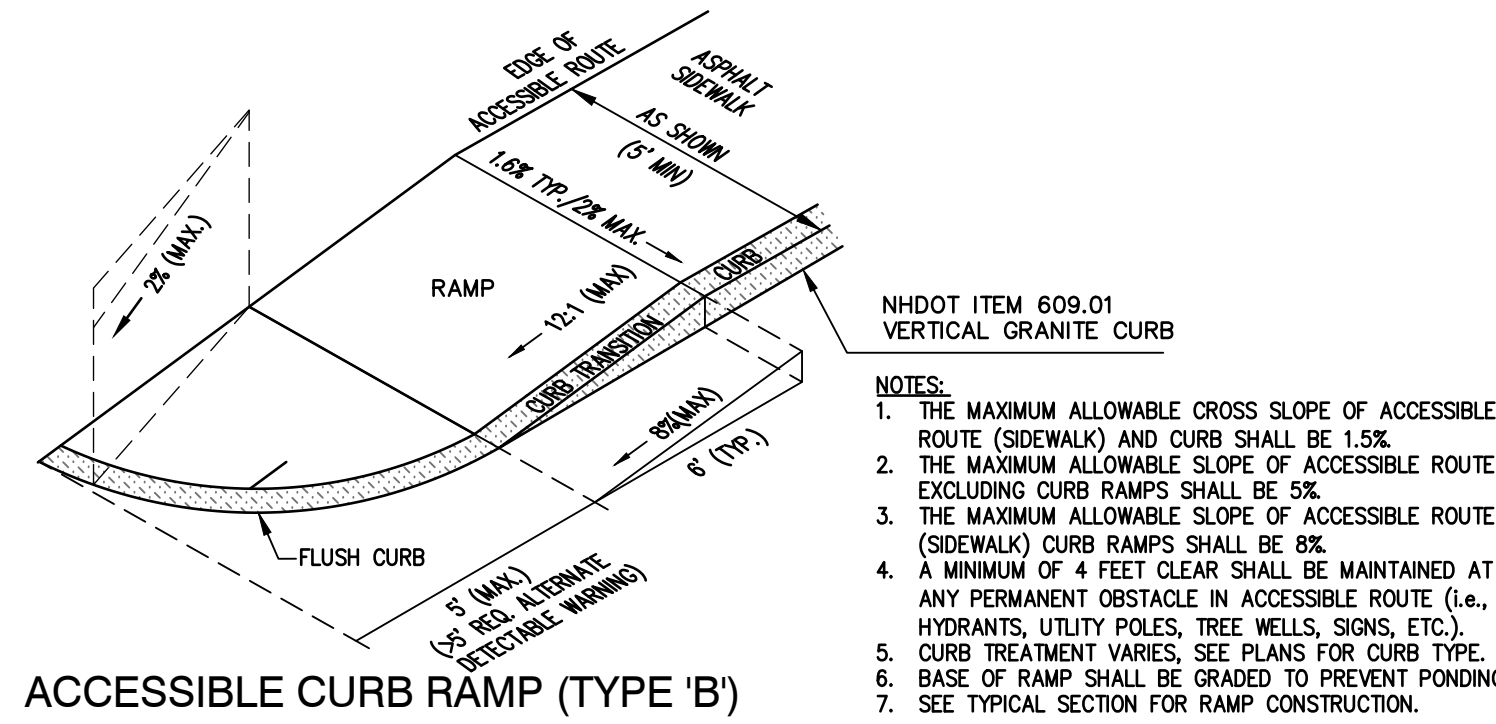

ACCESSIBLE CURB RAMP (TYPE 'B')

NOT TO SCALE

- NHDOT ITEM 609.01 VERTICAL GRANITE CURB
- NOTES:**
1. THE MAXIMUM ALLOWABLE CROSS SLOPE OF ACCESSIBLE ROUTE (SIDEWALK) AND CURB SHALL BE 1.5%.
 2. THE MAXIMUM ALLOWABLE SLOPE OF ACCESSIBLE ROUTE EXCLUDING CURB RAMP SHALL BE 5%.
 3. THE MAXIMUM ALLOWABLE SLOPE OF ACCESSIBLE ROUTE (SIDEWALK) CURB RAMP SHALL BE 8%.
 4. A MINIMUM OF 4 FEET CLEAR SHALL BE MAINTAINED AT ANY PERMANENT OBSTACLE IN ACCESSIBLE ROUTE (I.E., HYDRANTS, UTILITY POLES, TREE WELLS, SIGNS, ETC.).
 5. CURB TREATMENT VARIES, SEE PLANS FOR CURB TYPE.
 6. BASE OF RAMP SHALL BE GRADED TO PREVENT PONDING.
 7. SEE TYPICAL SECTION FOR RAMP CONSTRUCTION.

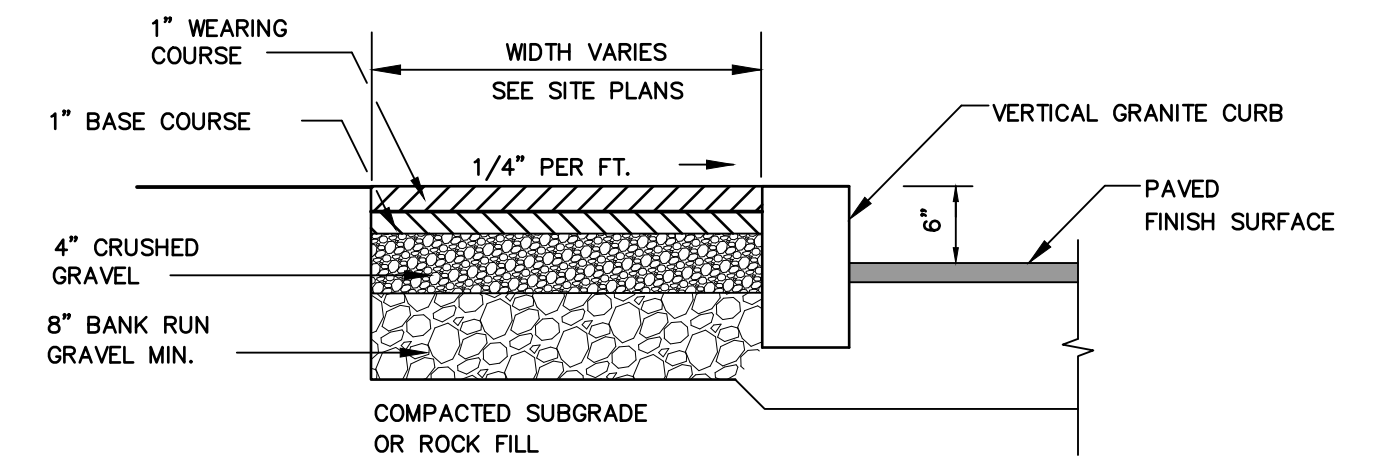

BIT. SIDEWALK W/ VERTICAL GRANITE CURB

NOT TO SCALE

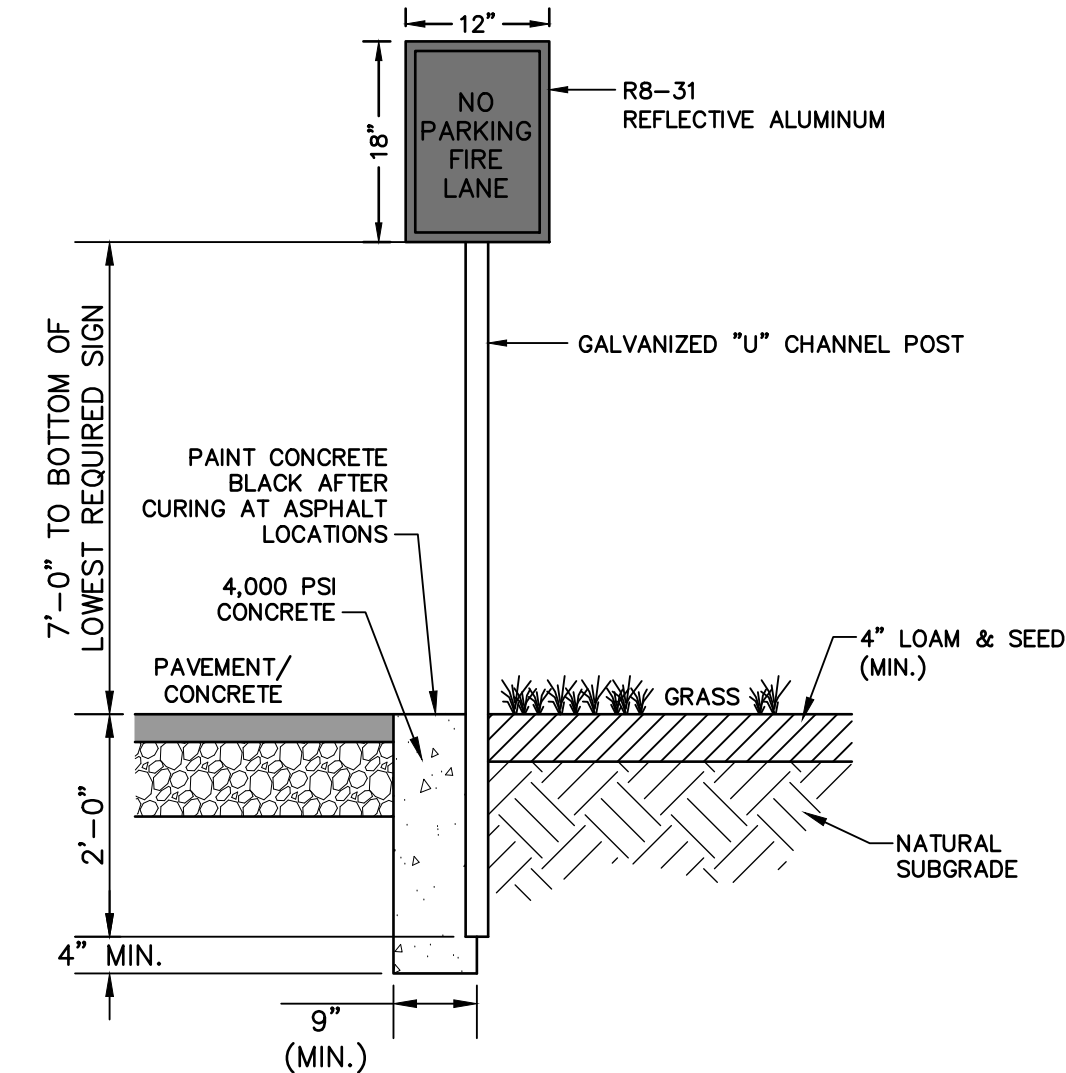

"NO PARKING" SIGN (MUTCD R8-31)

NOT TO SCALE

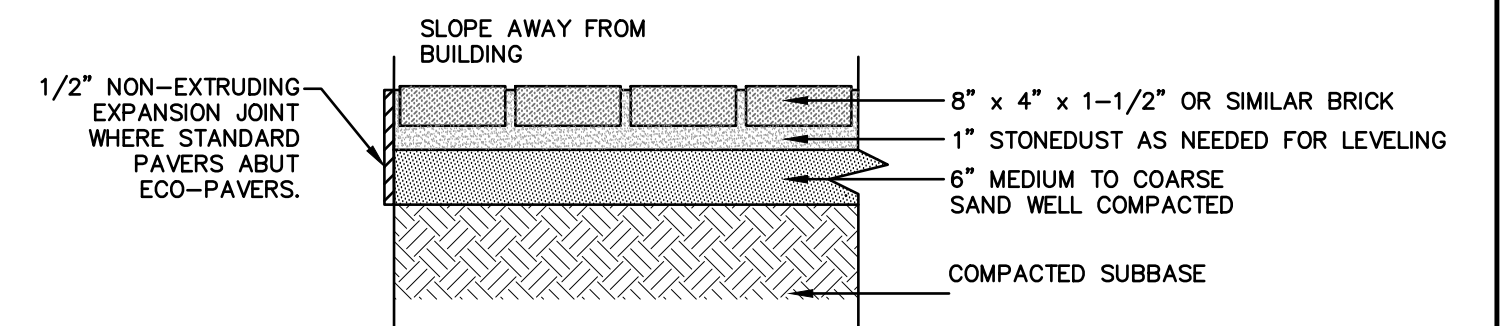

STANDARD BRICK PAVER

NOT TO SCALE

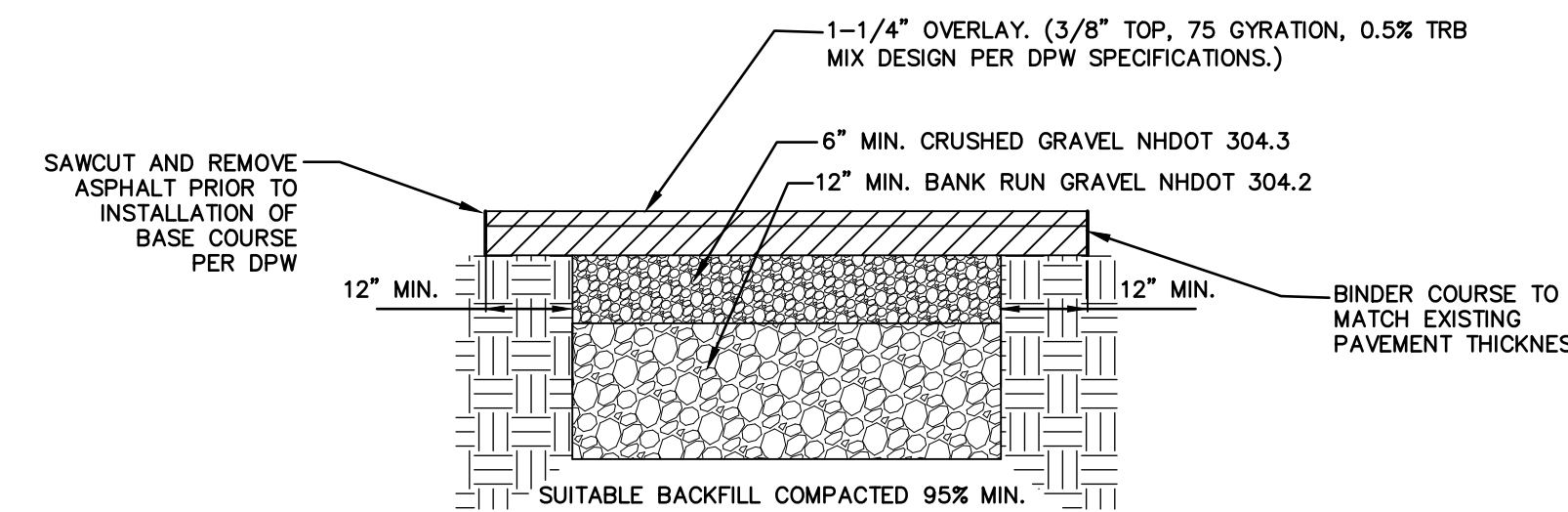

1. AFTER PROPER BACKFILLING AND COMPACTION, ADJACENT PAVEMENT MUST BE "SAW CUT" (STRAIGHT CUTS) A MINIMUM OF ONE FOOT (1') AROUND THE PERIMETER OF THE EXCAVATION. PAVEMENT MUST BE REMOVED.
2. INSTALL BASE COURSE LEAVING A REVEAL FOR SURFACE COURSE.
3. INSTALL SURFACE COURSE OF ASPHALT PAVING.
4. APPLY EMULSION SEALANT AT PERIMETER OF JOINT OVERLAPPING BASE COURSE. INSTALL WEARING COURSE OF ASPHALT TO GRADE. APPLY LIGHT SAND TO ABSORB EXCESS JOINT SEALANT.
5. GRAVEL COMPACTIONS TO MEET 95% MINIMUM.

TYPICAL PAVEMENT REPAIR DETAIL

NOT TO SCALE

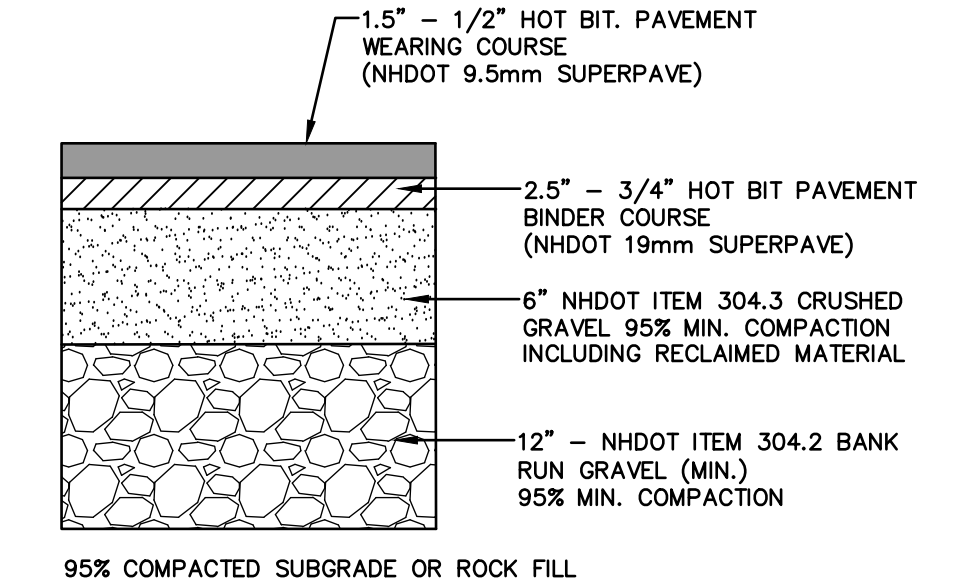

TYPICAL BITUMINOUS PAVEMENT

NOT TO SCALE

Design: DJM	Draft: KDR	Date: 2/26/2024
Checked: JAC	Scale: AS NOTED	Project No.: 18134.1
Drawing Name: 18134.1-PLAN.dwg		

THIS PLAN SHALL NOT BE MODIFIED WITHOUT WRITTEN PERMISSION FROM JONES & BEACH ENGINEERS, INC. (JBE). ANY ALTERATIONS, AUTHORIZED OR OTHERWISE, SHALL BE AT THE USER'S SOLE RISK AND WITHOUT LIABILITY TO JBE.

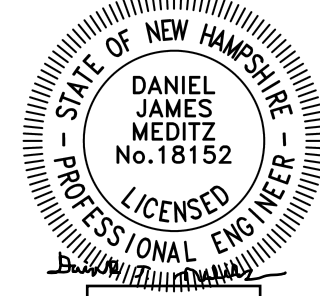

REV.	DATE	REVISION	BY
1	4/19/24	REVISED PER TAC COMMENTS	DJM
0	3/18/24	ISSUED FOR REVIEW	KDR
REV.	DATE	REVISION	BY

Designed and Produced in NH

J/B Jones & Beach Engineers, Inc.

85 Portsmouth Ave. Civil Engineering Services 603-772-4746
PO Box 219 Stratham, NH 03885 E-MAIL: JBE@JONESANDBEACH.COM

Plan Name:	DETAIL SHEET
Project:	LUSTER CLUSTER 635 SAGAMORE AVE., PORTSMOUTH, NH
Owner of Record:	635 SAGAMORE DEVELOPMENT LLC 3612 LAFAYETTE RD., DEPT 4, PORTSMOUTH, NH 03801 BK 6332 PG 1158

DRAWING No.	D1
SHEET 15 OF 20	JBE PROJECT NO. 18134.1

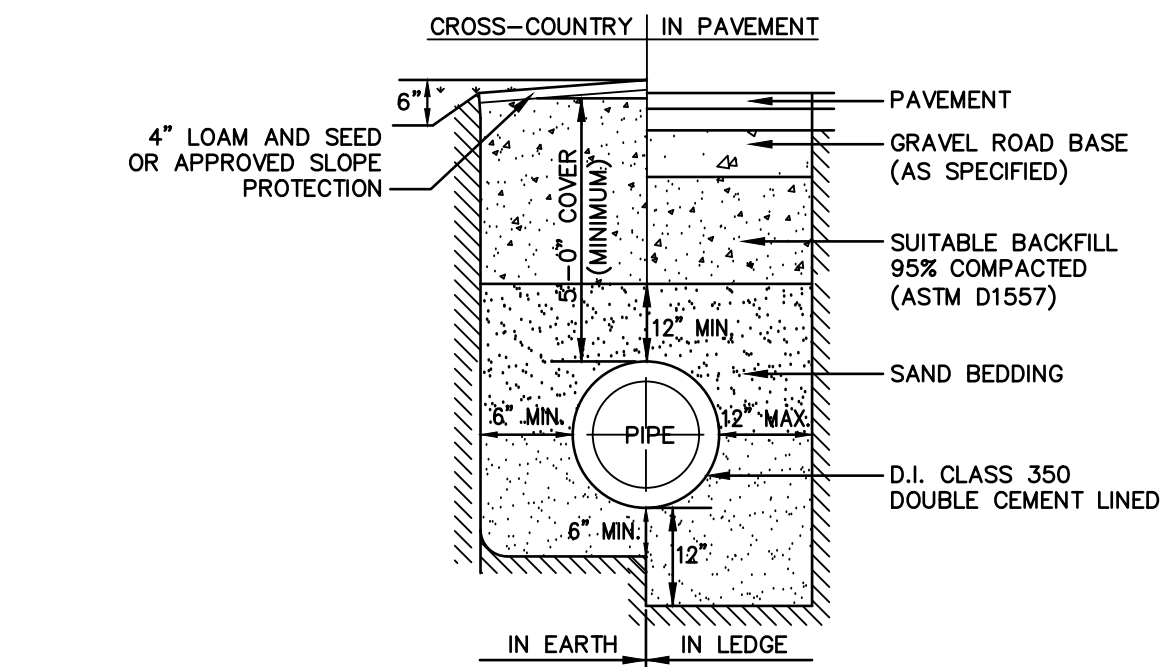

WATER SYSTEM TRENCH

NOT TO SCALE

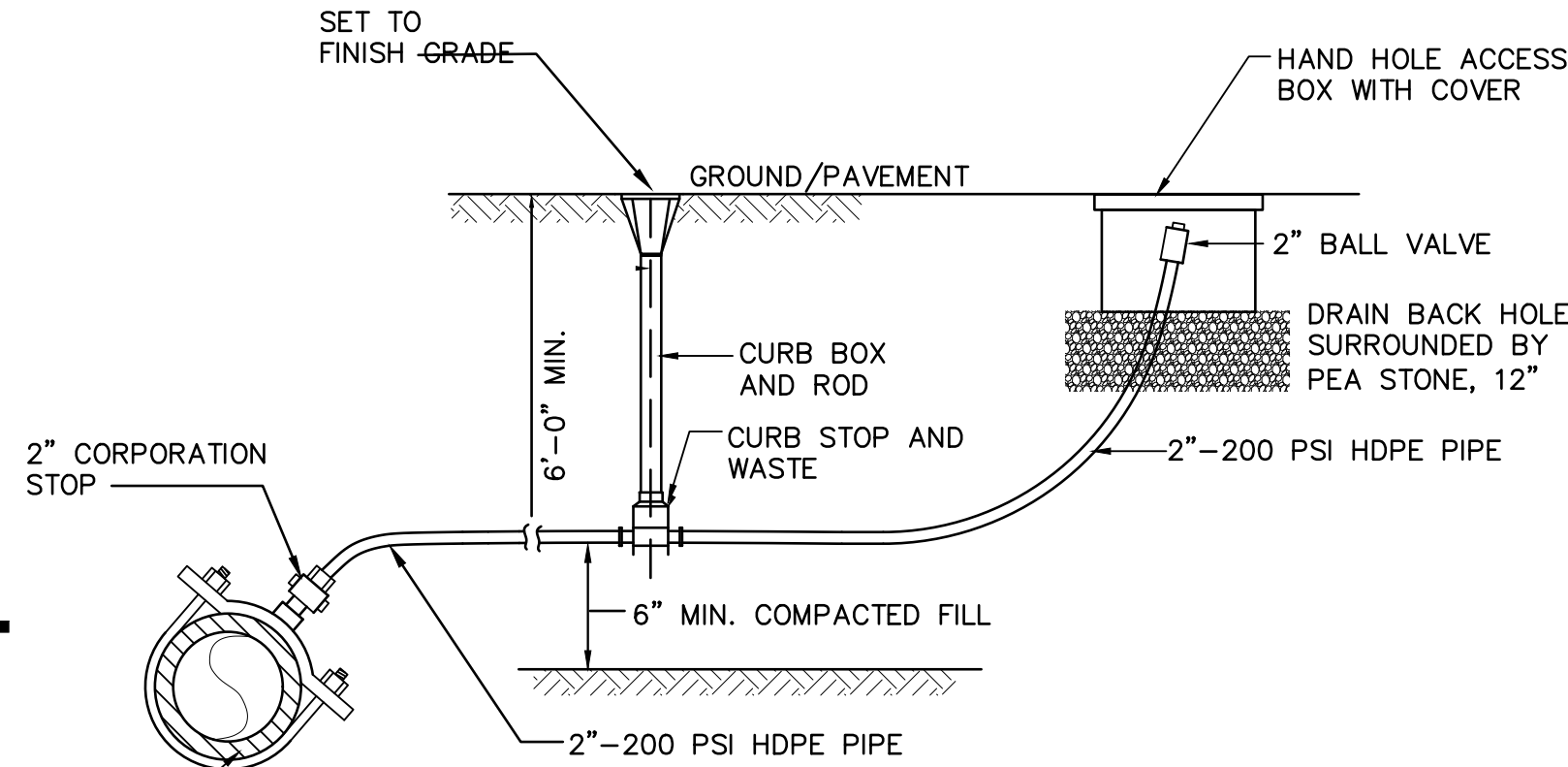

TYPICAL WATER MAIN BLOWOFF

NOT TO SCALE

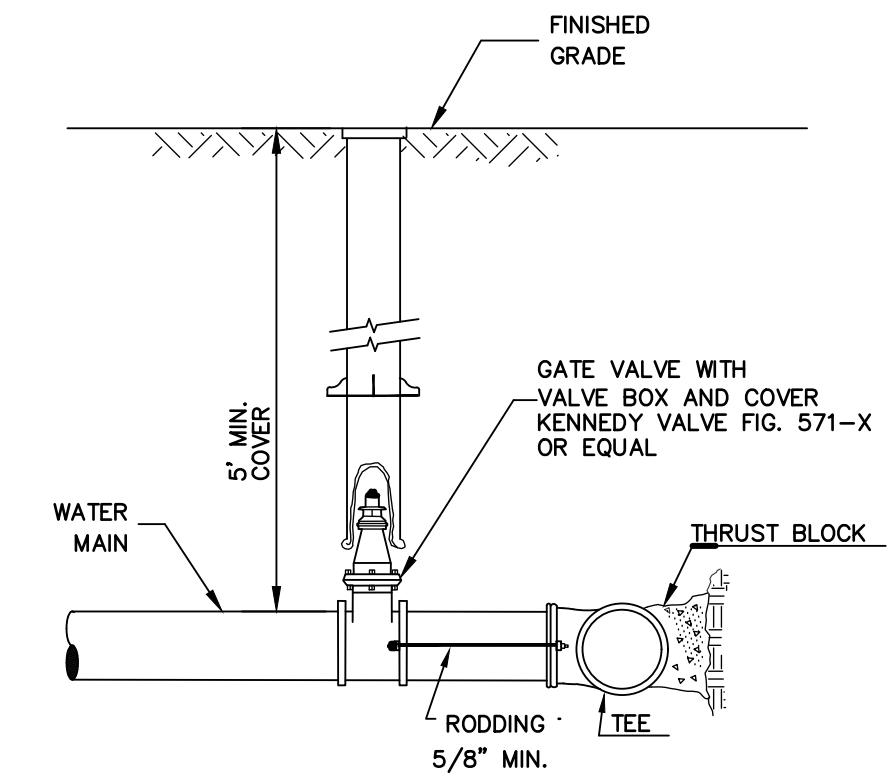

BURIED GATE VALVE DETAIL

NOT TO SCALE

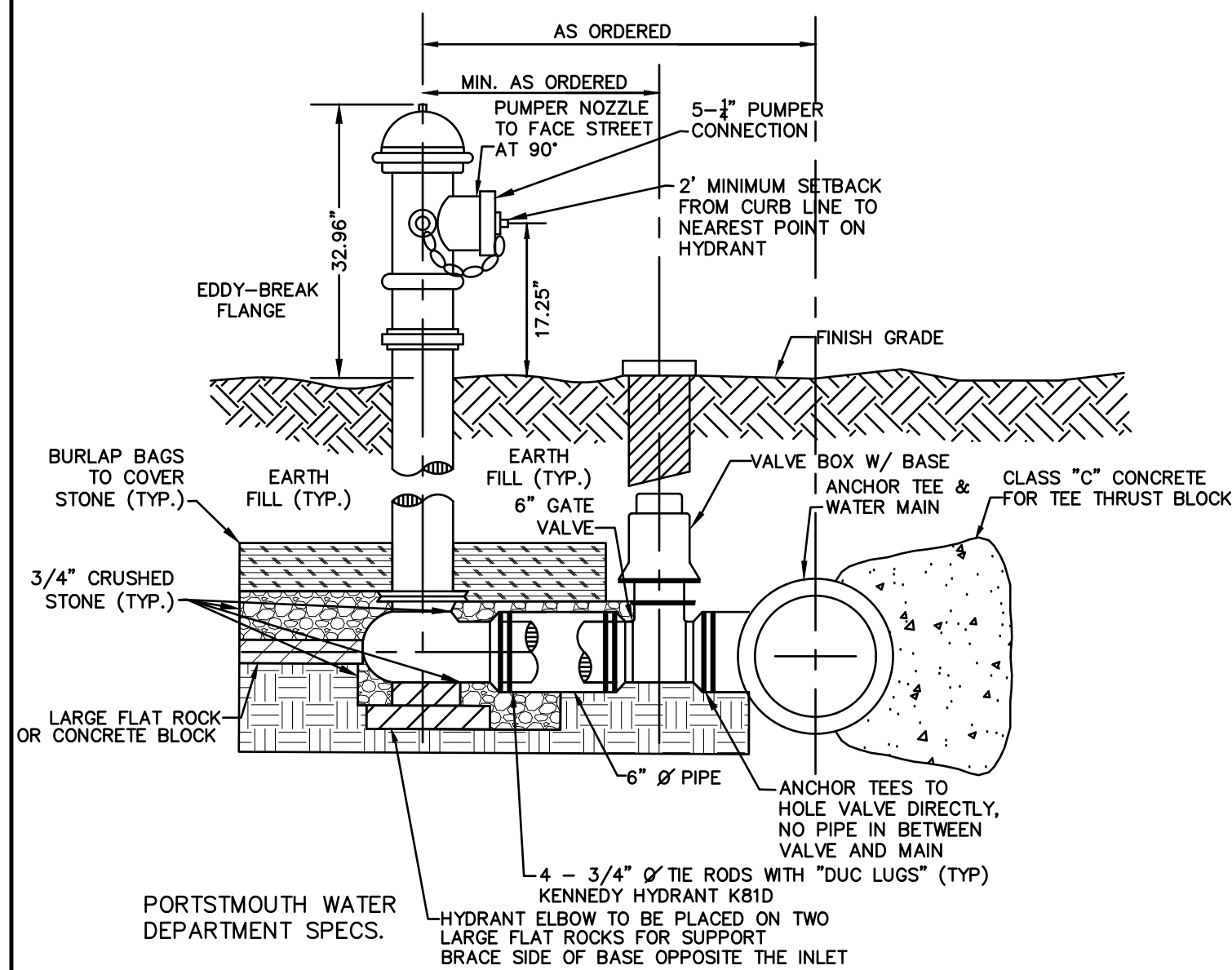

NOTES

1. ALL PIPE FITTINGS TO BE D.I. PRESSURE CLASS 350, THICKNESS CLASS 52.
2. HYDRANT TO BE PAINTED RED WITH WHITE "REFLECTOR" PAINT ON BONNET.
3. MECHANICAL JOINTS SHALL HAVE MEGALUG RETAINING GLANDS AS MADE BY EBBA OR APPROVED EQUAL.
4. NATIONAL STANDARD THREAD.
5. HYDRANT AND ALL VALVES SHALL OPEN RIGHT
6. ANCHOR TEES SHALL HOLD VALVE DIRECTLY WITH NO PIPE IN BETWEEN VALVE AND MAIN.

HYDRANT INSTALLATION

NOT TO SCALE

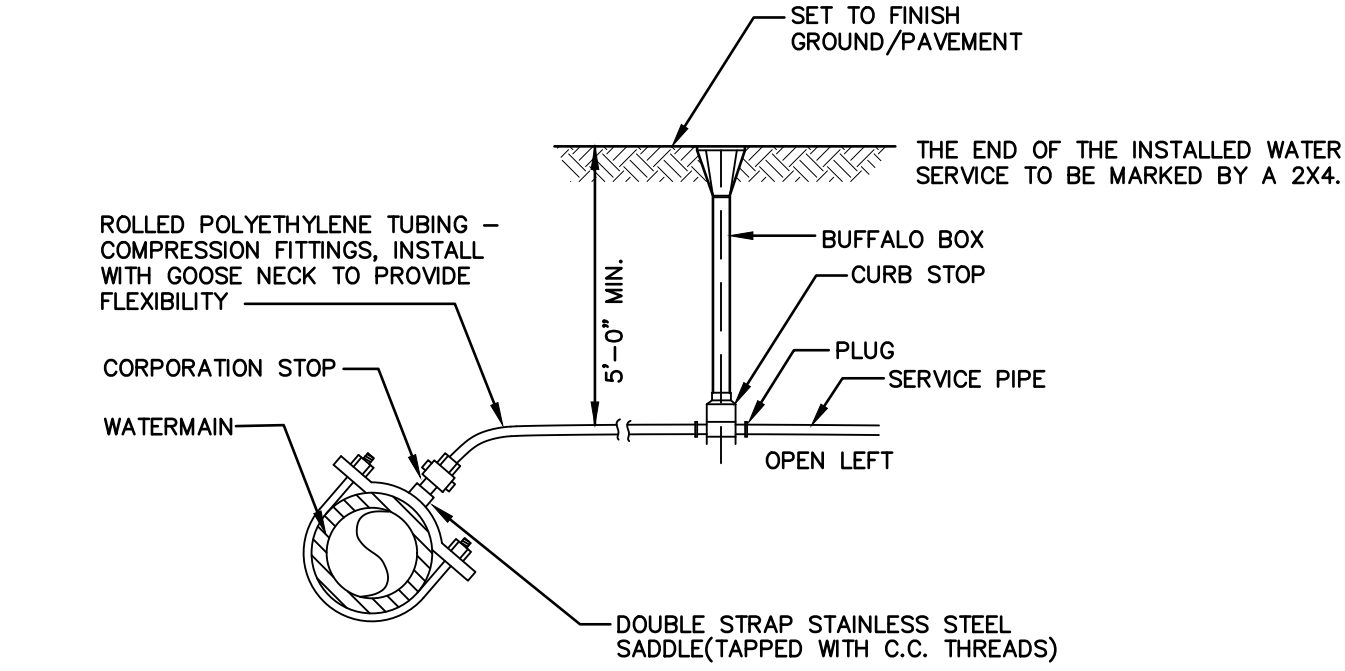

WATER SERVICE CONNECTION-POLYETHYLENE

NOT TO SCALE

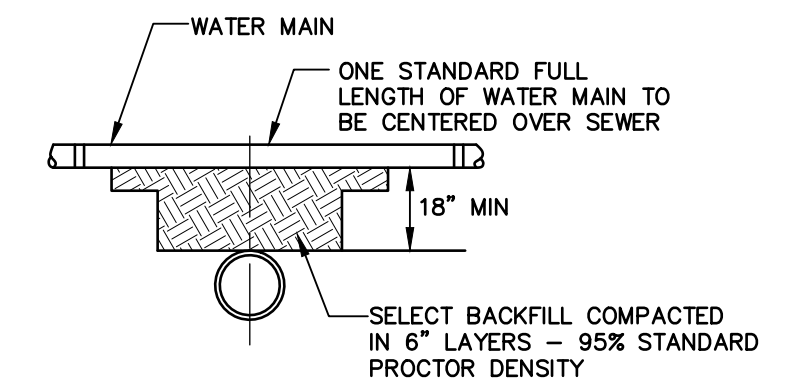

SEPARATION NOTES:

1. WATER MAINS SHALL BE LAID AT LEAST 10 FEET HORIZONTALLY FROM ANY EXISTING OR PROPOSED SEWERS. THE DISTANCE SHALL BE MEASURED EDGE TO EDGE.
2. WATER MAINS CROSSING SEWERS SHALL BE LAID TO PROVIDE A MINIMUM VERTICAL DISTANCE OF 18 INCHES BETWEEN PIPES. SEWER PIPE JOINTS SHALL BE LOCATED AT LEAST 6 FEET HORIZONTALLY FROM THE WATER MAIN.

TYPICAL WATER / SEWER SEPARATION

NOT TO SCALE

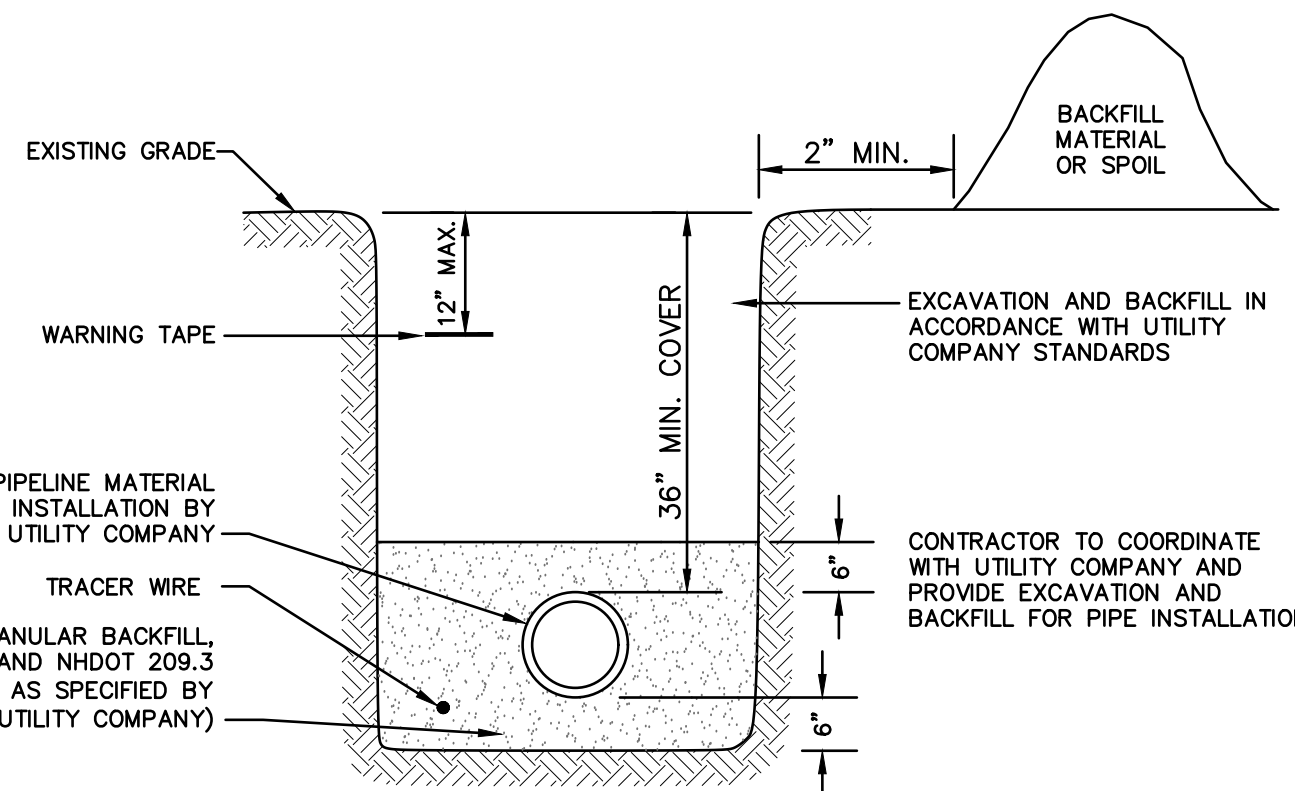

GAS TRENCH

NOT TO SCALE

SUBMITTALS

SHOP DRAWINGS, INCLUDING SPECIFICATIONS, CATALOG CUTS, DATA SHEETS, DRAWINGS AND OTHER DESCRIPTIVE MATERIAL SHALL BE SUPPLIED TO THE ENGINEER FOR REVIEW PRIOR TO INSTALLATION. A CERTIFICATE OF COMPLIANCE FROM THE MANUFACTURER INDICATING CONFORMANCE WITH THE SPECIFIED REQUIREMENTS FOR DUCTILE IRON PIPE SHALL BE SUBMITTED TO THE ENGINEER FOR REVIEW AND APPROVAL.

DELIVERY, HANDLING AND STORAGE

ALL PIPE AND APPURTENANCES ARE SUBJECT TO INSPECTION BY THE ENGINEER AT THE POINT OF DELIVERY. MATERIAL FOUND TO BE DEFECTIVE DUE TO MANUFACTURE OR DAMAGE IN SHIPMENT SHALL BE REJECTED OR RECORDED ON THE BILL OF LADING AND REMOVED FROM THE JOB SITE. ALL MATERIALS, IF STORED, SHALL BE KEPT SAFE FROM ANY POTENTIAL DAMAGE.

SAND BEDDING

SAND BLANKET SHALL CONSIST OF CLEAN SAND THAT IS FREE FROM ORGANIC MATTER AND GRADED SO THAT 90-100% PASSES A 1/2" SIEVE AND NOT MORE THAN 15% WILL PASS A #200 SIEVE.

BACKFILL

SUITABLE MATERIAL FOR BACKFILL IN ROADS, ROAD SHOULDERS, AND WALKWAYS SHALL BE THE NATURAL MATERIAL REMOVED DURING THE COURSE OF TRENCH EXCAVATION, BUT SHALL EXCLUDE ANY DEBRIS, PAVEMENT, ORGANIC MATTER, LOAM, WET OR SOFT MUCK, PEAT, OR CLAY. BACKFILL MATERIAL SHALL BE PLACED IN 6" LIFTS AND SHALL BE COMPACTED TO 95% OF ASTM-1557 AT OPTIMUM MOISTURE CONTENT.

DUCTILE IRON PIPE-CLASS 52

JOINTS SHALL BE OF "PUSH-ON" TYPE UNLESS OTHERWISE SPECIFIED. PIPE SHALL HAVE A DOUBLE CEMENT LINING WITH SEAL COATING INSIDE AND BITUMINOUS COATING OUTSIDE THAT MEETS OR EXCEEDS THE REQUIREMENTS OF AWWA/ANSI C104/A21.4. GASKETS FOR DUCTILE IRON PIPE SHALL BE OIL-RESISTANT RUBBER WHICH MEETS OR EXCEEDS THE REQUIREMENTS OF AWWA/ANSI C111/A21.11. PIPE SHALL BE FURNISHED COMPLETE WITH ALL GASKETS AND LUBRICANT.

WATERMAIN TESTING

ALL WATER MAINS WILL BE CLEANED AND HYDROSTATICALLY TESTED AT A MINIMUM PRESSURE OF 150psi AT THE HIGHEST POINT ALONG THE TEST SECTION. THE HYDROSTATIC TEST SHALL BE CONDUCTED FOR A MINIMUM OF TWO HOURS DURING WHICH TEST PRESSURE SHALL NOT VARY MORE THAN ±5psi. LEAKAGE CALCULATIONS WILL BE COMPLETED IN ACCORDANCE WITH THE REQUIREMENTS OF THE AMERICAN WATER WORKS ASSOCIATION. DISINFECTION WILL BE REQUIRED PER THE SPECIFICATIONS OF ANSI/AWWA C651. WITHIN 24 HOURS OF DISINFECTION, ALL NEWLY INSTALLED MAINS SHALL BE FLUSHED.

WATER LINE TECHNICAL SPECIFICATIONS

NOTES

1. CONTRACTOR TO INSTALL 2" RIGID INSULATION BETWEEN THE PROPOSED WATERMAIN(S) AND DRAINAGE LINES IN ALL AREAS WHERE SEPARATION IS TO BE IN 4' OR LESS.
2. ALL PIPE, FITTINGS, HYDRANTS, AND WORKMANSHIP SHALL BE INSPECTED AND APPROVED BY THE MUNICIPAL WATER/SEWER DEPARTMENT.
3. ALL CONSTRUCTION AND TESTING SHALL COMPLY WITH THE REGULATIONS OF THE MUNICIPAL, THE STATE, AND THE AMERICAN WATER WORKS ASSOCIATION.
4. THE CONTRACTOR SHALL BE RESPONSIBLE FOR VERIFYING AND DETERMINING THE LOCATION, SIZE, AND ELEVATION OF ALL EXISTING UTILITIES PRIOR TO THE START OF CONSTRUCTION. THE ENGINEER SHALL BE NOTIFIED IN WRITING OF ANY UNFORESEEN UTILITY FOUND INTERFERING WITH THE PROPOSED CONSTRUCTION. ANY APPROPRIATE REMEDIAL ACTION MUST BE AGREED TO BY THE ENGINEER PRIOR TO THE COMMENCEMENT OF WORK. THE CONTRACTOR SHALL BE RESPONSIBLE FOR CONTACTING "DIG-SAFE" AT 1-888-344-7233 AT LEAST 72 HOURS BEFORE DIGGING.
5. ALL CONCRETE SHALL HAVE A COMPRESSIVE STRENGTH OF NOT LESS THAN 2000 PSI AFTER 28 DAYS.
6. CONTRACTOR TO INSTALL CORPORATION FITTINGS AT EACH CONNECTION TO THE WATER MAIN FOR TESTING PURPOSES. CORPORATIONS SHALL BE REMOVED AND PLUGGED AT THE COMPLETION OF TESTING.
7. CONTRACTOR TO OBSERVE ALL APPROPRIATE BEST MANAGEMENT PRACTICES.
8. ALL GATE VALVES TO BE MUELLER RESILIENT WEDGE (OPEN RIGHT).
9. ALL TEES TO BE ANCHOR TEES.
10. THE TERMINAL 36" OF ALL "DEAD END" WATERMANS AND ALL BENDS AND TEES ARE TO BE FITTED WITH MECHANICAL RESTRAINING JOINTS, "MEGALUG" OR APPROVED EQUAL AND THRUST BLOCKS.
11. INSTALL THRUST BLOCKS AT ALL TEES, BENDS, AND FITTINGS.

PIPE DIA. (IN.)	CONCRETE THRUST BLOCK DIMENSIONS							
	TEE	90° BEND OR STUB	45° BEND	22.5° BEND	TEE	90° BEND OR STUB	45° BEND	22.5° BEND
4"/6"	1'-6"	1'-6"	1'-6"	2'-0"	1'-6"	1'-6"	1'-6"	1'-6"
6"	2'-0"	2'-0"	2'-0"	3'-0"	1'-6"	2'-0"	1'-6"	1'-6"
8"	2'-0"	3'-0"	2'-6"	3'-6"	2'-0"	2'-6"	1'-6"	2'-0"
10"	2'-6"	3'-6"	3'-0"	4'-0"	2'-0"	3'-6"	1'-6"	2'-6"
12"	3'-0"	4'-6"	3'-6"	5'-6"	3'-0"	3'-6"	2'-0"	2'-6"
15"	4'-0"	5'-0"	4'-6"	6'-0"	3'-6"	4'-0"	2'-6"	3'-0"
18"	5'-0"	7'-0"	6'-0"	8'-0"	4'-0"	6'-0"	3'-0"	4'-6"

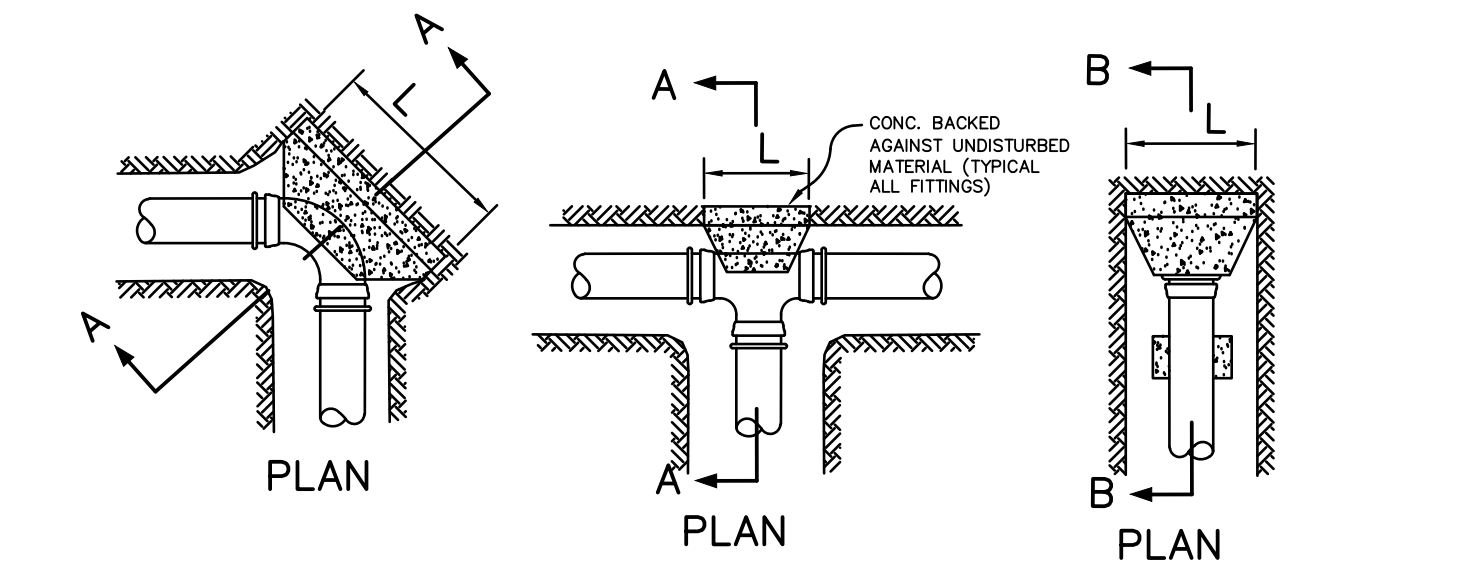

THRUST BLOCK DETAILS

NOT TO SCALE

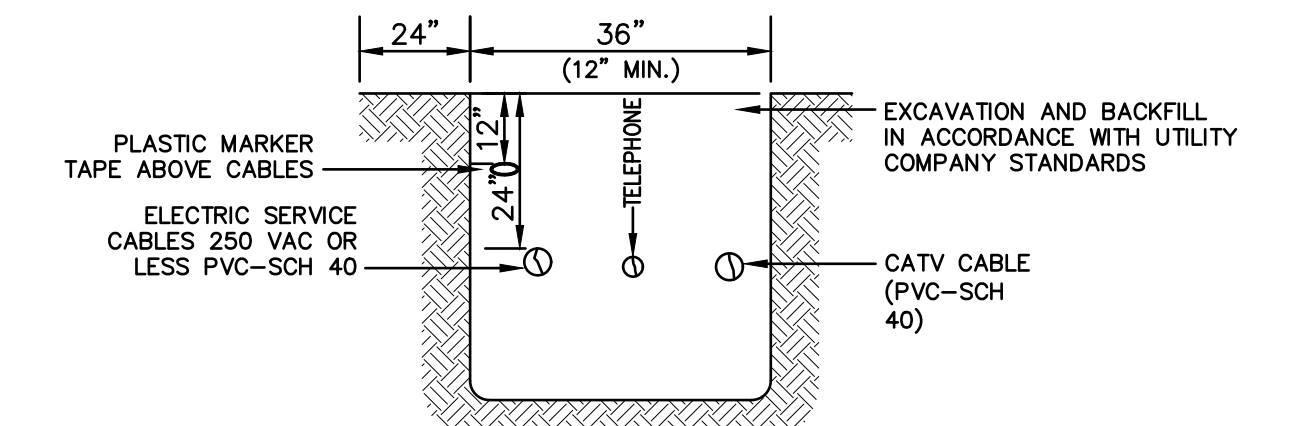

NOTE: ALL UTILITIES SHALL BE REVIEWED AND APPROVED BY APPROPRIATE UTILITY COMPANY.

UTILITY TRENCH

NOT TO SCALE

Design: DJM	Draft: KDR	Date: 2/26/2024
Checked: JAC	Scale: AS NOTED	Project No.: 18134.1
Drawing Name: 18134.1-PLAN.dwg		
THIS PLAN SHALL NOT BE MODIFIED WITHOUT WRITTEN PERMISSION FROM JONES & BEACH ENGINEERS, INC. (JBE). ANY ALTERATIONS, AUTHORIZED OR OTHERWISE, SHALL BE AT THE USER'S SOLE RISK AND WITHOUT LIABILITY TO JBE.		

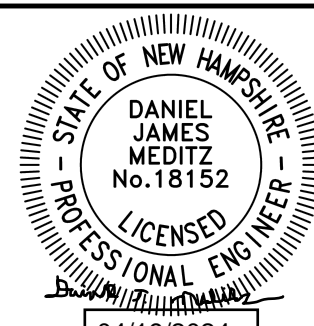

REV.	DATE	REVISION	BY
1	4/19/24	REVISED PER TAC COMMENTS	DJM
0	3/18/24	ISSUED FOR REVIEW	KDR

Designed and Produced in NH

J/B Jones & Beach Engineers, Inc.

85 Portsmouth Ave. Civil Engineering Services 603-772-4746
 PO Box 219 Stratham, NH 03885 E-MAIL: JBE@JONESANDBEACH.COM

Plan Name:	DETAIL SHEET
Project:	LUSTER CLUSTER 635 SAGAMORE AVE., PORTSMOUTH, NH
Owner of Record:	3612 LAFAYETTE RD., DEPT 4, PORTSMOUTH, NH 03801 BK 6332 PG 1158

DRAWING No.	D2
SHEET 16 OF 20	JBE PROJECT NO. 18134.1

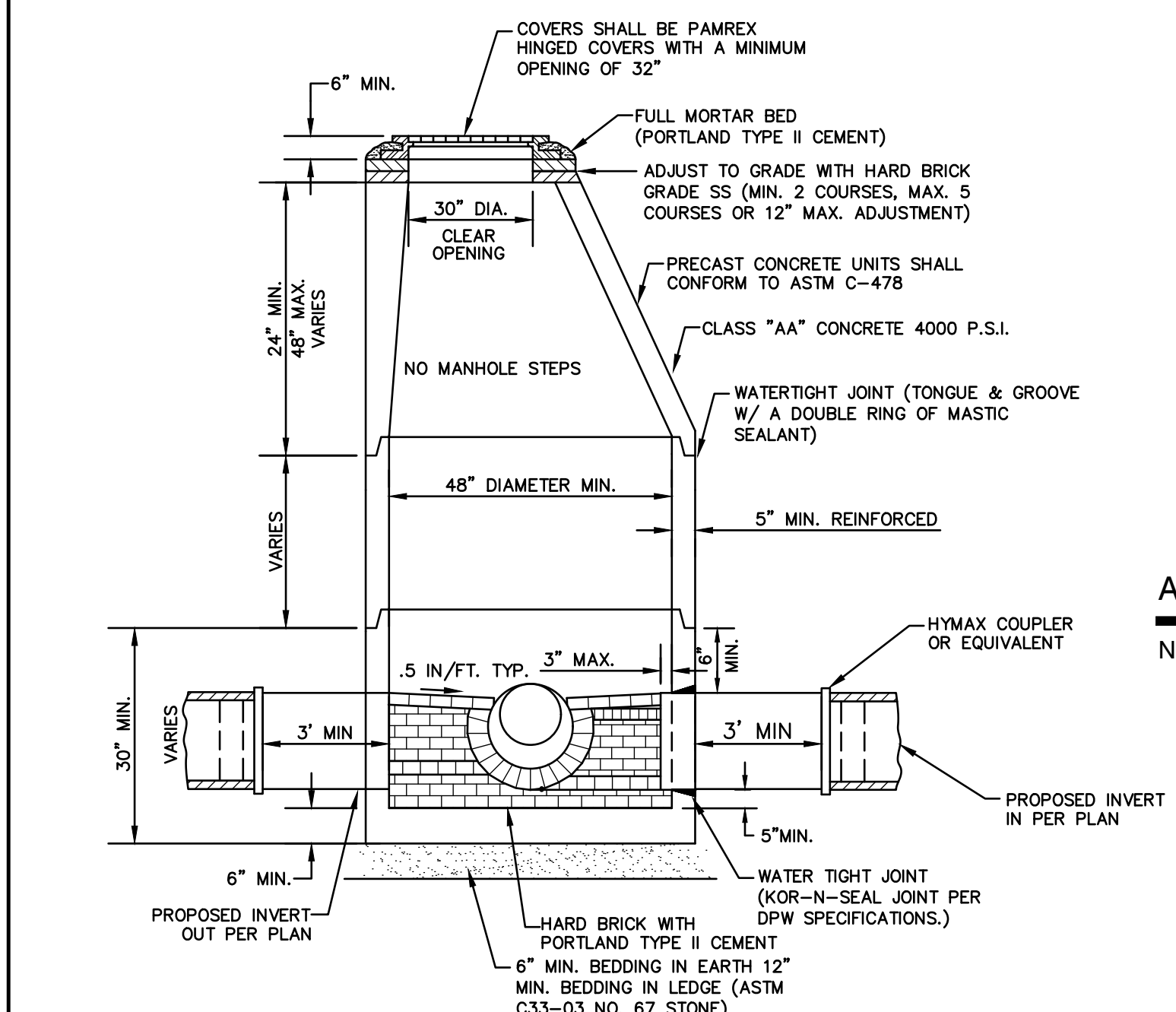
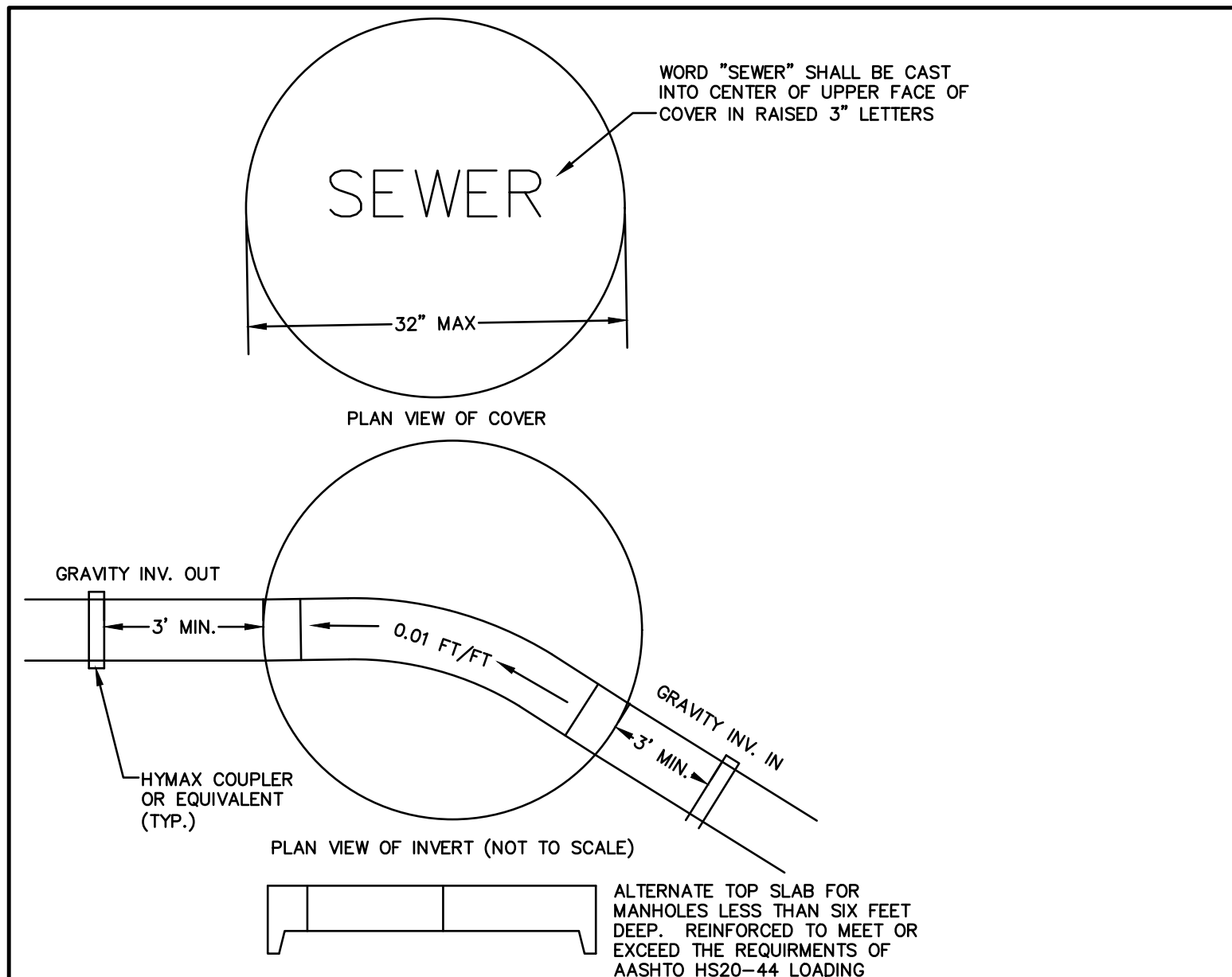

- NOTES:**
- PER NHDES ENV-WQ 704.13(C), THE MORTAR SPECIFICATION SHALL BE AS FOLLOWS:
 1. MORTAR SHALL BE COMPOSED OF PORTLAND CEMENT AND SAND WITH OR WITHOUT HYDRATED LIME ADDITION;
 2. PROPORTIONS IN MORTAR OF PARTS BY VOLUMES SHALL BE:
 A. 4.5 PARTS SAND AND 1.5 PARTS CEMENT; OR
 B. 4.5 PARTS SAND, ONE PART CEMENT AND 0.5 PART HYDRATED LIME;
 3. CEMENT SHALL BE TYPE II PORTLAND CEMENT CONFORMING TO ASTM C150-05;
 4. HYDRATED LIME SHALL BE TYPE S CONFORMING TO THE ASTM C207-06 STANDARD SPECIFICATIONS FOR HYDRATED LIME FOR MASONRY PURPOSES;
 5. SAND SHALL CONSIST OF INERT NATURAL SAND CONFORMING TO THE ASTM C33-03 STANDARD SPECIFICATIONS FOR CONCRETE, FINE AGGREGATES;
 - SHELVES SHALL BE CONSTRUCTED TO THE ELEVATION OF THE HIGHEST PIPE CROWN AND SLOPED TO DRAIN TOWARD THE FLOWING THROUGH CHANNEL IN ACCORDANCE WITH ENV-WQ 704.12 (K).
 - ALL MANHOLES SHALL BE TESTED FOR LEAKAGE IN ACCORDANCE WITH ENV-WQ 704.17 (a) THROUGH (e).
 - SEWER MANHOLE COVERS SHALL CONFORM TO ASTM A48 WITH A CASTING EQUAL TO CLASS 30 IN ACCORDANCE WITH ENV-WQ 704.13 (a).
 - ALL ASBESTOS CONTAINING WASTE MATERIALS MUST BE PROPERLY IDENTIFIED, PACKAGED AND DELIVERED TO A LANDFILL LICENCED BY THE NHDES SOLID WASTE MANAGEMENT PROGRAM FOR DISPOSAL. CALL (603) 271-2925 FOR MORE INFORMATION.
 - PORTSMOUTH STANDARD SEWER MANHOLE SHALL BE USED.
 - CONTRACTOR TO PURCHASE SEWER MANHOLE COVERS FROM THE CITY OF PORTSMOUTH DIRECTLY.
 - MANHOLE BASE SECTIONS SHALL BE MONOLITHIC TO A POINT AT LEAST 6" ABOVE THE HIGHEST INCOMING SEWER PIPE PER ENV-WQ 704.12 (e).
 - MANHOLE CASTINGS SHALL CONFORM TO ASTM A48 PER ENV-WQ 704.13 (a) (b).

PORTSMOUTH SEWER MANHOLE
NOT TO SCALE

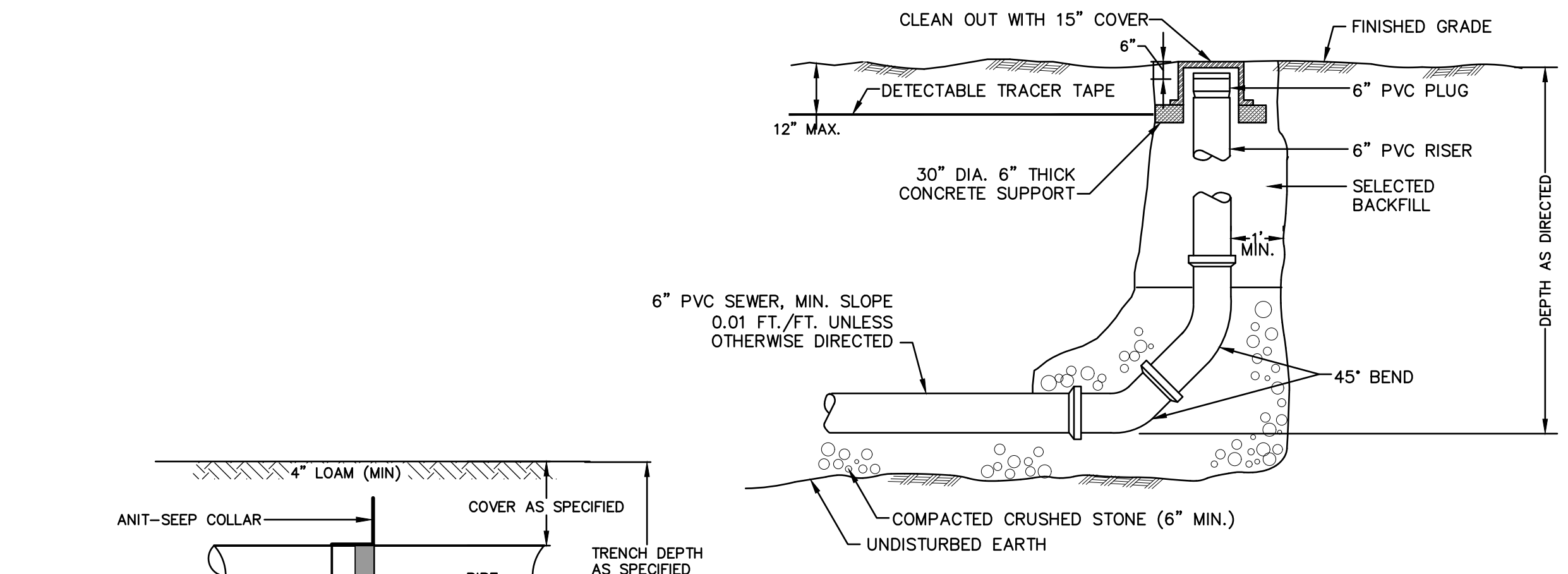

SEWER CLEAN OUT
NOT TO SCALE

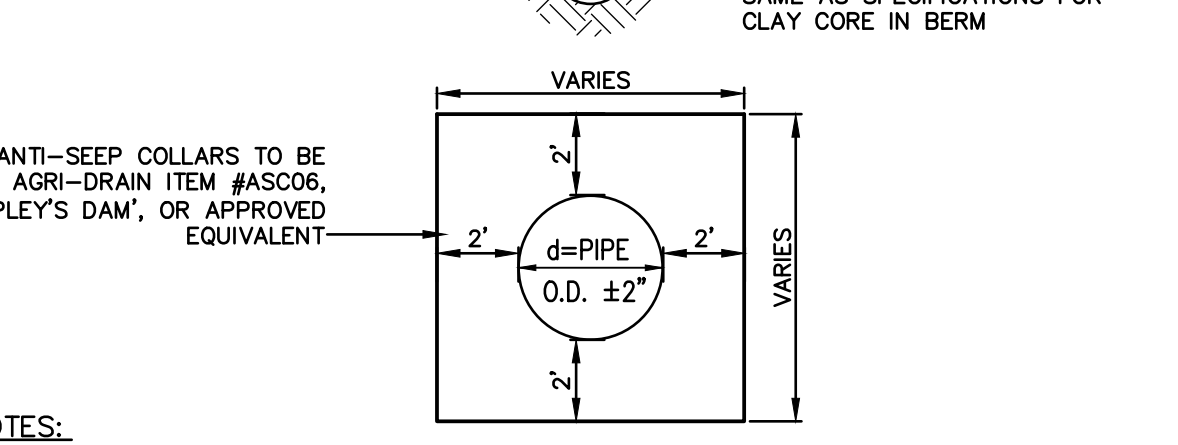

- NOTES:**
- CONTRACTOR SHALL INSTALL COLLAR(S) PER MANUFACTURER'S SPECIFICATIONS.
 - CONTRACTOR SHALL ENSURE A WATERTIGHT SEAL BETWEEN THE COLLAR(S) AND PIPE(S).
 - ANTI-SEEP COLLARS SHALL BE PLACED ±15' AND ±25' DOWNSTREAM OF THE CULVERT INLETS, UNLESS OTHERWISE SPECIFIED. WHEN A CLAY CORE IS SPECIFIED, A COLLAR SHALL BE INSTALLED ON BOTH SIDES OF THE CORE.

ANTI-SEEP COLLAR
NOT TO SCALE

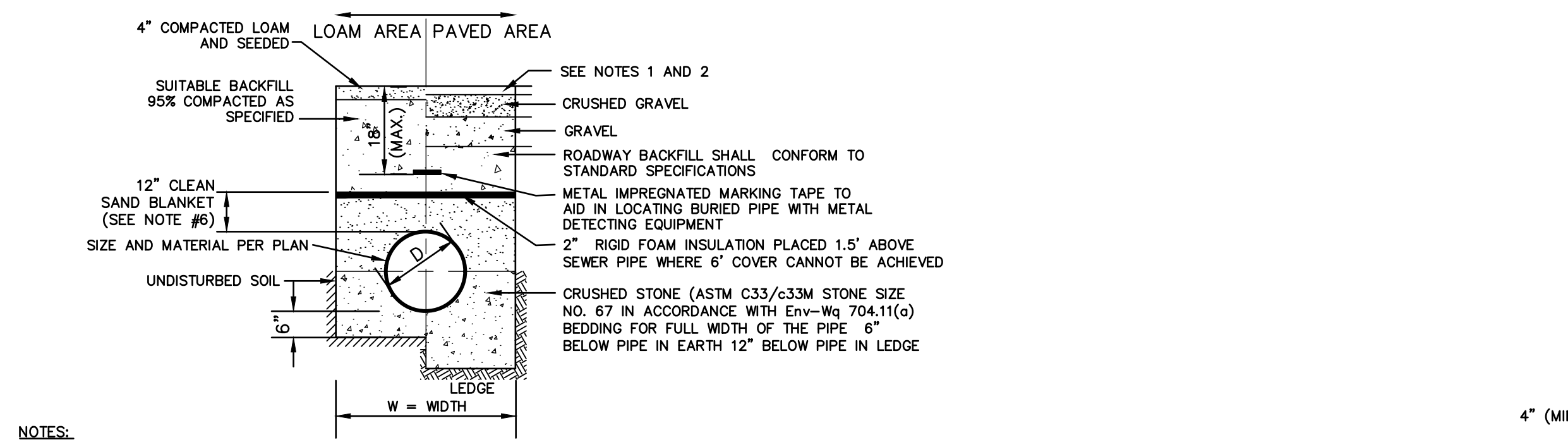

- NOTES:**
- PAVEMENT REPAIR IN EXISTING ROADWAYS SHALL CONFORM TO PAVEMENT DETAILS.
 - NEW ROADWAY CONSTRUCTION SHALL CONFORM TO SUBDIVISION SPECIFICATIONS.
 - TRENCH BACKFILL SHALL CONFORM WITH ENV. Wq 704.11(h) AND BE FREE OF DEBRIS, PAVEMENT, ORGANIC MATTER, TOP SOIL, WET OR SOFT MUCK, PEAT OR CLAY, EXCAVATED LEDGE OR ROCKS OVER SIX INCHES.
 - W = MAXIMUM ALLOWABLE TRENCH WIDTH TO A PLANE 12" INCHES ABOVE THE PIPE. FOR PIPES 15 INCHES NOMINAL DIAMETER OR LESS, WIDTH SHALL BE NO MORE THAN 36"; FOR PIPES GREATER THAN 15 INCHES NOMINAL DIAMETER, WIDTH SHALL BE 24 INCHES PLUS PIPE O.D. WIDTH SHALL ALSO BE THE PAYMENT WIDTH FOR LEDGE EXCAVATION AND FOR ORDERED EXCAVATION BELOW GRADE.
 - RIGID FOAM INSULATION TO BE PROVIDED WHERE COVER IN THE ROADWAY IS LESS THAN 6' AND CROSS COUNTRY IS LESS THAN 4', PURSUANT TO DES WAIVER BEING ISSUED.
 - PIPE SAND BLANKET MATERIAL SHALL BE GRADED SAND, FREE FROM ORGANIC MATERIALS, GRADED SUCH THAT 100% PASSES A 1/2" SIEVE AND A MAXIMUM OF 15% PASSES A #200 SIEVE IN ACCORDANCE WITH ENV-Wq 704.11(b).
 - JOINT SEALS FOR PVC PIPE SHALL BE OIL RESISTANT COMPRESSION RINGS OF ELASTOMERIC MATERIAL AND CERTIFIED BY THE MANUFACTURER AS CONFORMING TO THE ASTM D3212 STANDARD IN EFFECT WHEN THE JOINT SEALS WERE MANUFACTURED, AND SHALL BE PUSH-ON, BELL-AND-SPIGOT TYPE PER ENV-Wq 704.05 (e).
 - PVC PIPE SHALL CONFORM WITH ASTM D3034 AND ASTM D2412.

GRAVITY SEWER TRENCH
NOT TO SCALE

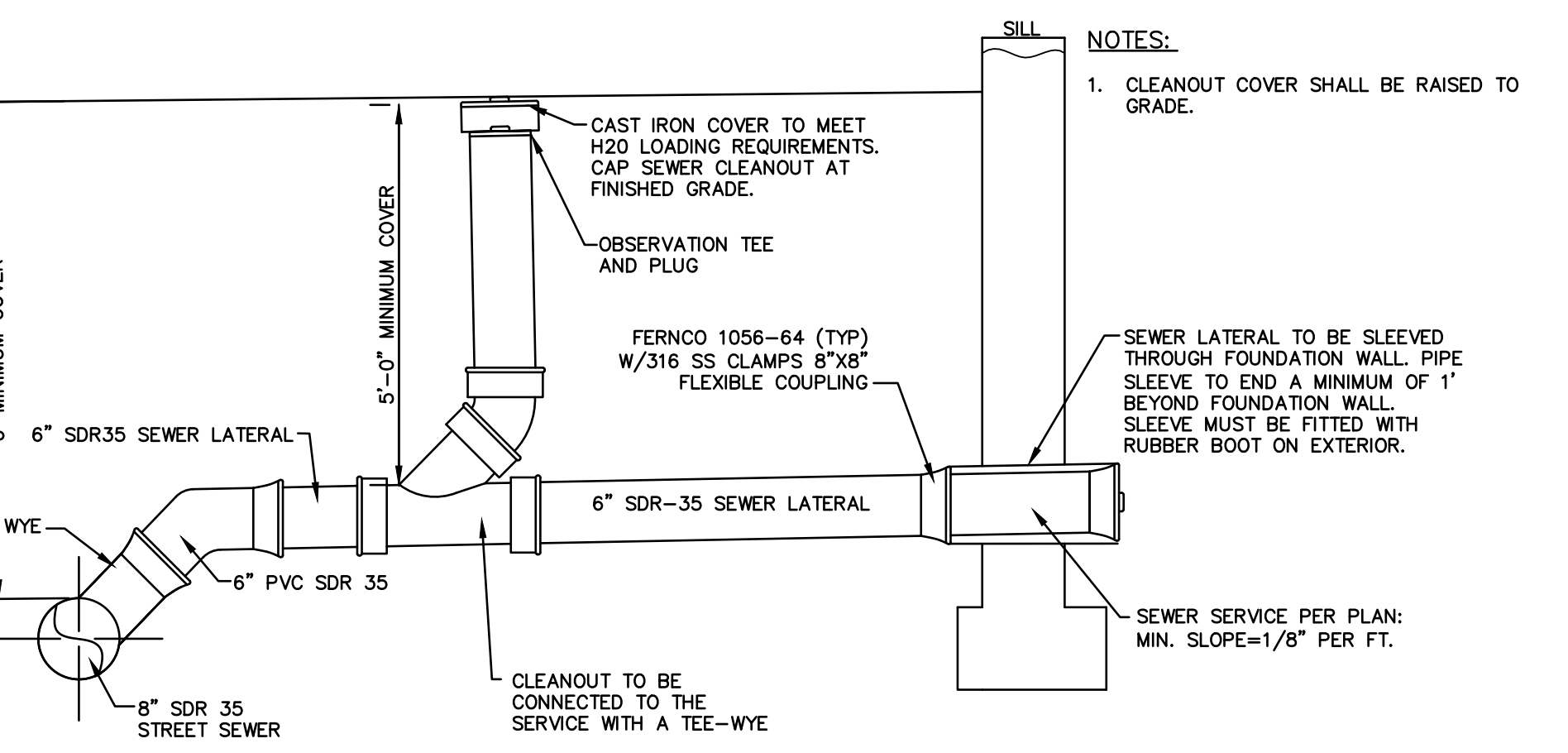

HOUSE SEWER SERVICE
NOT TO SCALE

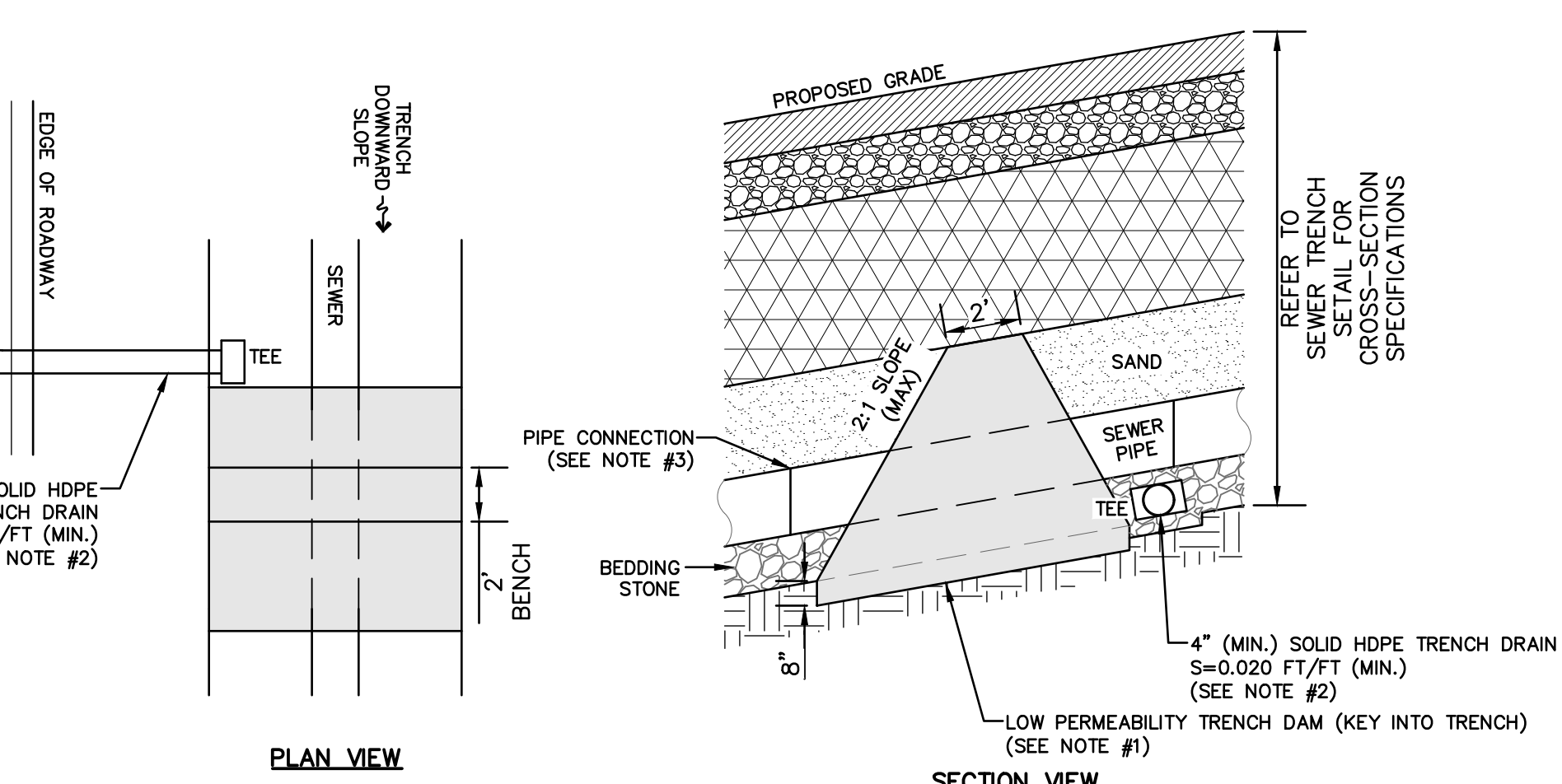

- NOTES:**
- LOW PERMEABILITY SOIL USED FOR TRENCH DAM SHALL MEET THE FOLLOWING SPECIFICATION: CLAYEY SOIL - MIN. 15% PASSING THE #200 SIEVE AND A MIN. PERMEABILITY OF 1x10⁻⁵ CM/SEC
 - DRAINS SHALL DAYLIGHT TO NEAREST AT-GRADE POINT, TIE INTO A DRAINAGE STRUCTURE, OR INTO A NETWORK OR TRENCH DRAINS.
 - CONTRACTOR SHALL NOT LOCATE A PIPE CONNECTION WITHIN THE LIMITS OF THE TRENCH DAM. A 2' SEPARATION BETWEEN LIMIT OF TRENCH DAM AND CONNECTION IS RECOMMENDED.
 - CONTRACTOR SHALL INSTALL DAMS & DRAINS AT A MAXIMUM .75' SPACING. REFER TO PROJECT PLANS.

SEWER TRENCH DAM & DRAIN
NOT TO SCALE

Design: DJM	Draft: KDR	Date: 2/26/2024
Checked: JAC	Scale: AS NOTED	Project No.: 18134.1
Drawing Name: 18134.1-PLAN.dwg		
THIS PLAN SHALL NOT BE MODIFIED WITHOUT WRITTEN PERMISSION FROM JONES & BEACH ENGINEERS, INC. (JBE). ANY ALTERATIONS, AUTHORIZED OR OTHERWISE, SHALL BE AT THE USER'S SOLE RISK AND WITHOUT LIABILITY TO JBE.		

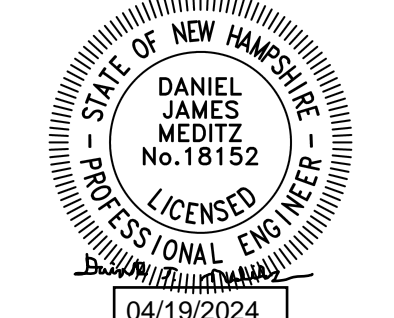

REV.	DATE	REVISION	BY
0	4/19/24	REVISED PER TAC COMMENTS	DJM
1	3/18/24	ISSUED FOR REVIEW	KDR

Designed and Produced in NH

J/B Jones & Beach Engineers, Inc.

85 Portsmouth Ave. PO Box 219 Stratham, NH 03885

Civil Engineering Services

603-772-4746

E-MAIL: JBE@JONESANDBEACH.COM

Plan Name:	DETAIL SHEET
Project:	LUSTER CLUSTER 635 SAGAMORE AVE., PORTSMOUTH, NH
Owner of Record:	635 SAGAMORE DEVELOPMENT LLC 3612 LAFAYETTE RD., DEPT 4, PORTSMOUTH, NH 03801 BK 6332 PG 1158

DRAWING No.

D3

SHEET 17 OF 20
JBE PROJECT NO. 18134.1

BIORETENTION SYSTEM ELEVATIONS	
ELEVATION	SYSTEM #1
A	63.00
B	60.60
C	59.10
D	58.85
E	58.10
BOTTOM SURFACE AREA (S.F.)	466

SAND SPECIFICATION	
SIEVE SIZE	% BY WEIGHT
#4	100
#8	95-100
#16	80-100
#30	50-85
#60	25-60
#100	10-30
#200	2-10
	0-5

TOPSOIL SPECIFICATION
LOAMY SAND TOPSOIL WITH MINIMAL CLAY CONTENT AND BETWEEN 15 TO 25% FINES PASSING THE #200 SIEVE.

MULCH SPECIFICATION
MODERATELY FINE, SHREDDED BARK OR WOOD FIBER MULCH WITH LESS THAN 5% PASSING THE #200 SIEVE.

PEA GRAVEL SPECIFICATION	
SIEVE SIZE	% BY WEIGHT
#4	100
#8	85-100
#16	10-30
#30	0-10
#60	0-15

COARSE GRAVEL SPECIFICATION	
SIEVE SIZE	% BY WEIGHT
#16	100
#30	75-100
#60	50-100
#100	15-80
#200	0-15
	0-5

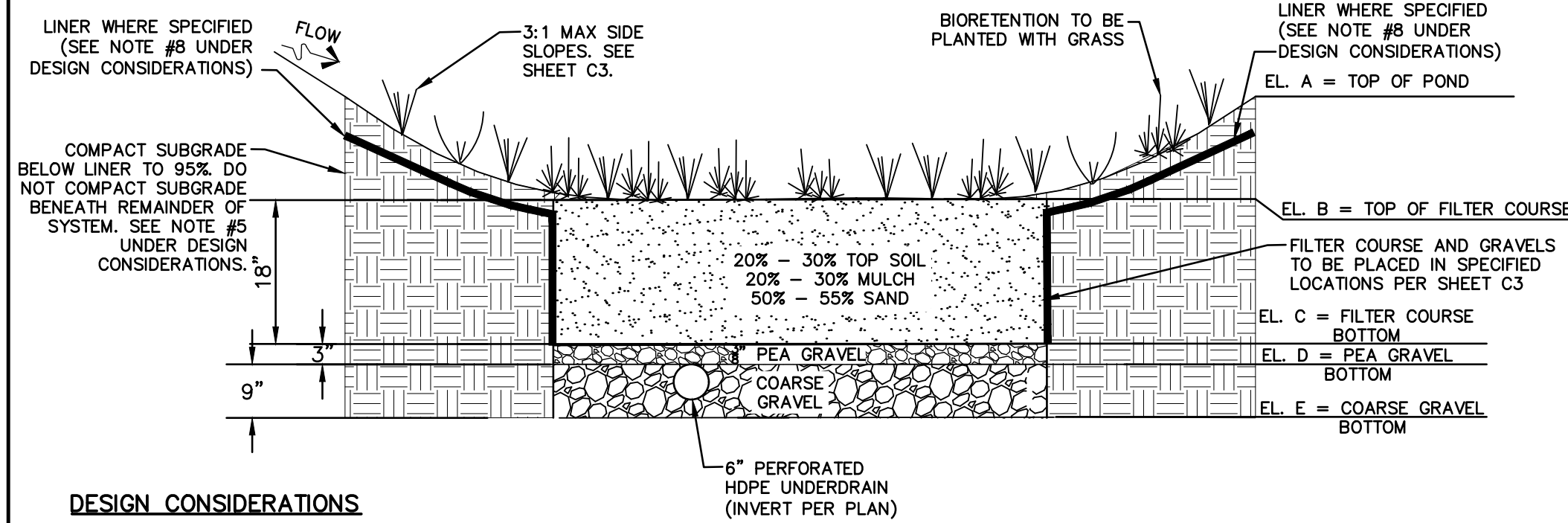

DESIGN CONSIDERATIONS

- DO NOT PLACE BIORETENTION SYSTEMS INTO SERVICE UNTIL THE BMP HAS BEEN SEEDING AND ITS CONTRIBUTING AREAS HAVE BEEN FULLY STABILIZED.
- DO NOT DISCHARGE SEDIMENT-LADEN WATERS FROM CONSTRUCTION ACTIVITIES (RUN-OFF, WATER FROM EXCAVATIONS) TO THE BIORETENTION AREA DURING ANY STAGE OF CONSTRUCTION.
- DO NOT TRAFFIC EXPOSED SOIL SURFACE WITH CONSTRUCTION EQUIPMENT. IF FEASIBLE, PERFORM EXCAVATIONS WITH EQUIPMENT OUTSIDE THE LIMITS OF THE INFILTRATION COMPONENTS OF THE SYSTEM.
- REMOVE LEDGE TO AT LEAST 6" BELOW BOTTOM OF COARSE GRAVEL LAYER IF ENCOUNTERED.
- IN ADDITION TO DESIGN CRITERIA LISTED HERE, REFER TO GUIDELINES LISTED IN UNIVERSITY OF NEW HAMPSHIRE (UNH) STORMWATER CENTER BIORETENTION SOIL SPECIFICATION.
- UPSTREAM DEEP SUMP CATCH BASINS PROVIDE PRE-TREATMENT IN LIEU OF A SEDIMENT FOREBAY.
- ONLY PLACE FILTER MEDIA AND STONE BENEATH DOTTED HATCH AREA ON SHEET C3. REMAINDER OF POND TO BE LINED WITH 30ML LINER 6" BELOW SURFACE. FILTER MEDIA AND STONE SECTIONS ARE NOT TO BE LINED. LINER SHALL CONTINUE DOWN THE SIDES OF THE FILTER COURSE BUT MUST NOT BE PLACED ON THE SIDES OF THE PEA GRAVEL OR COARSE GRAVEL OR PLACED BENEATH THE FILTER COURSE AND/OR GRAVELS.
- THE EXISTING NATIVE SUBGRADE MATERIAL SHALL NOT BE COMPACTED OR SUBJECT TO EXCESSIVE CONSTRUCTION EQUIPMENT TRAFFIC PRIOR TO STONE PLACEMENT. IF SOIL MEDIA OR SUBGRADE IS OVER COMPACTED, DISTURBED, OR CONTAMINATED BY FOREIGN OR DELETERIOUS MATERIALS OR LIQUIDS, REMOVE THE SOIL MEDIA AND CONTAMINATION; RESTORE THE SUBGRADE AS DIRECTED BY ENGINEER AND REPLACE CONTAMINATED SOIL MEDIA WITH NEW SOIL MEDIA.

MAINTENANCE REQUIREMENTS:

- SYSTEMS SHALL BE INSPECTED AT LEAST TWICE ANNUALLY, AND FOLLOWING ANY RAINFALL EVENT EXCEEDING 2.5 INCHES IN A 24 HOUR PERIOD, WITH MAINTENANCE OR REHABILITATION CONDUCTED AS WARRANTED BY SUCH INSPECTION.
- PRE-TREATMENT MEASURES SHALL BE INSPECTED AT LEAST TWICE ANNUALLY, AND CLEANED OF ACCUMULATED SEDIMENT AS WARRANTED BY INSPECTION, BUT NO LESS THAN ONCE ANNUALLY.
- TRASH AND DEBRIS SHALL BE REMOVED AT EACH INSPECTION.
- AT LEAST ONCE ANNUALLY, SYSTEM SHALL BE INSPECTED FOR DRAWDOWN TIME. IF BIORETENTION SYSTEM DOES NOT DRAIN WITHIN 72 HOURS FOLLOWING A RAINFALL EVENT, THEN A QUALIFIED PROFESSIONAL SHALL ASSESS THE CONDITION OF THE FACILITY TO DETERMINE MEASURES REQUIRED TO RESTORE FILTRATION FUNCTION, INCLUDING BUT NOT LIMITED TO REMOVAL OF ACCUMULATED SEDIMENTS OR RECONSTRUCTION OF THE FILTER MEDIA.
- VEGETATION SHALL BE INSPECTED AT LEAST ANNUALLY, AND MAINTAINED IN HEALTHY CONDITION, INCLUDING PRUNING, REMOVAL AND REPLACEMENT OF DEAD OR DISEASED VEGETATION, AND REMOVAL OF INVASIVE SPECIES.
- COMPACTION AND MATERIALS TESTING SERVICES SHALL BE PERFORMED BY AN INDEPENDENT GEOTECHNICAL ENGINEER RETAINED BY THE OWNER.

BIORETENTION SYSTEM WITH UNDERDRAIN

NOT TO SCALE

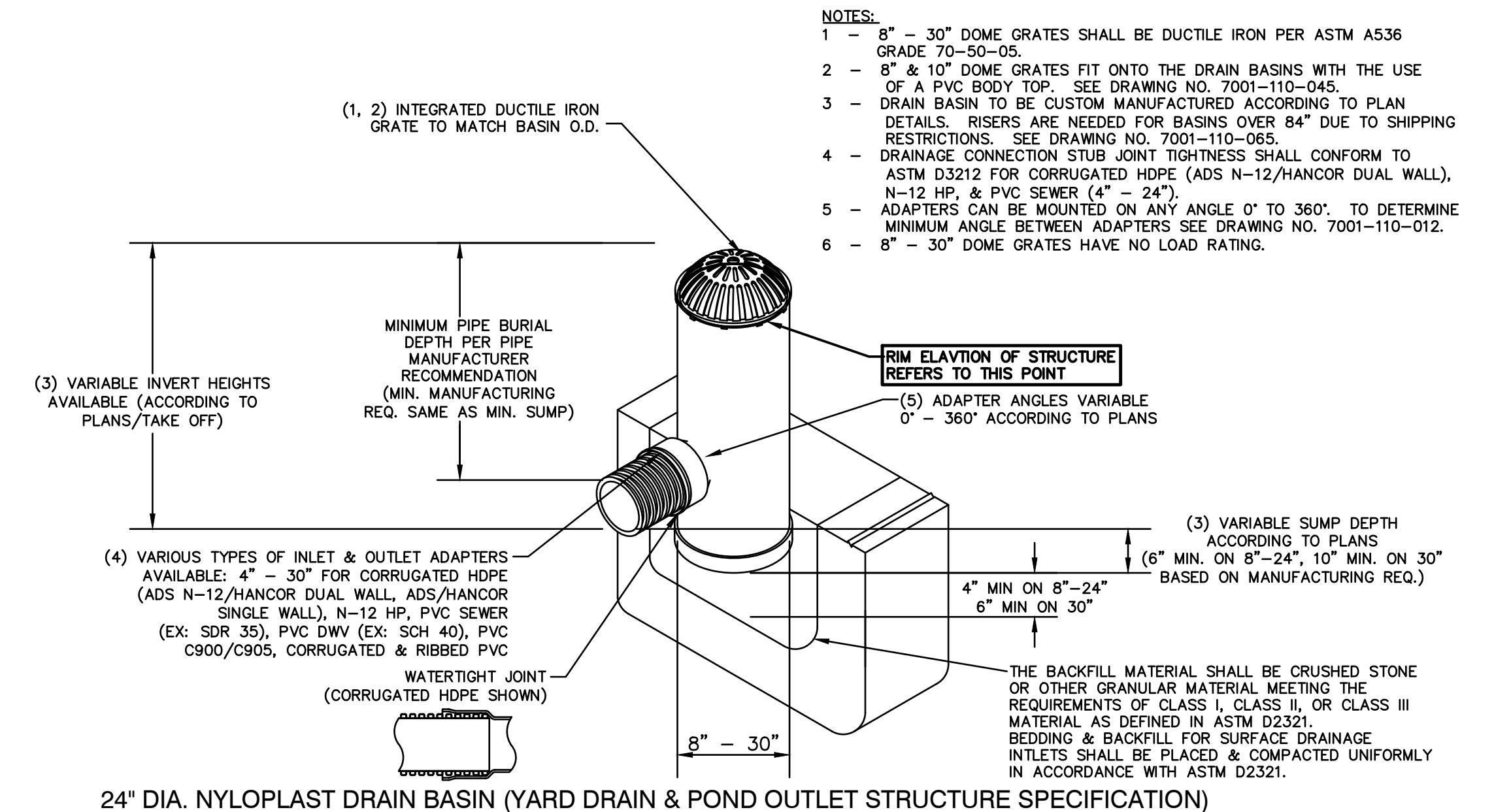

24" DIA. NYLOPLAST DRAIN BASIN (YARD DRAIN & POND OUTLET STRUCTURE SPECIFICATION)

NOT TO SCALE

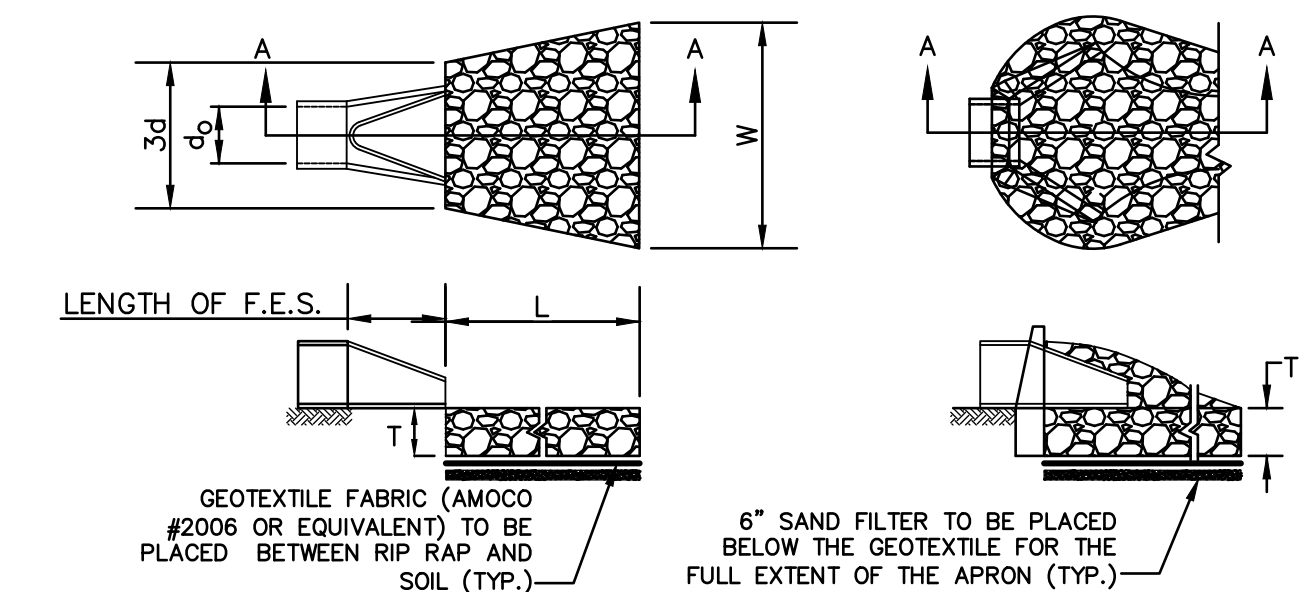

SECTION A-A

PIPE OUTLET TO FLAT AREA WITH NO DEFINED CHANNEL

SECTION A-A

PIPE OUTLET TO WELL-DEFINED CHANNEL

TABLE 7-24--RECOMMENDED RIP RAP GRADATION RANGES			
THICKNESS OF RIP RAP = 1.5 FEET			
d50 SIZE=	0.25 FEET	3 INCHES	
% OF WEIGHT SMALLER THAN THE GIVEN d50 SIZE	SIZE OF STONE (INCHES) FROM	TO	
100%	5	6	
85%	4	5	
50%	3	5	
15%	1	2	

NOTES:

- THE SUBGRADE FOR THE GEOTEXTILE FABRIC AND RIP RAP SHALL BE PREPARED TO THE LINES AND GRADES SHOWN ON THE PLANS.
- THE RIP RAP SHALL CONFORM TO THE SPECIFIED GRADATION.
- GEOTEXTILE FABRICS SHALL BE PROTECTED FROM PUNCTURE OR TEARING DURING THE PLACEMENT OF THE ROCK RIP. DAMAGED AREAS IN THE FABRIC SHALL BE REPAIRED BY PLACING A PIECE OF FABRIC OVER THE DAMAGED AREA OR BY COMPLETE REPLACEMENT OF THE FABRIC. ALL OVERLAPS REQUIRED FOR REPAIRS OR JOINING TWO PIECES OF FABRIC SHALL BE A MINIMUM OF 12 INCHES.
- STONE FOR THE RIP RAP MAY BE PLACED BY EQUIPMENT AND SHALL BE CONSTRUCTED TO THE FULL LAYER THICKNESS IN ONE OPERATION AND IN SUCH A MANNER AS TO PREVENT SEGREGATION OF THE STONE SIZES.
- OUTLETS TO A DEFINED CHANNEL SHALL HAVE 2:1 OR FLATTER SIDE SLOPES AND SHOULD BEGIN AT THE TOP OF THE CURVE AND TAPER DOWN TO THE CHANNEL BOTTOM THROUGH THE LENGTH OF THE APRON.
- MAINTENANCE:** THE OUTLET PROTECTION SHOULD BE CHECKED AT LEAST ANNUALLY AND AFTER EVERY MAJOR STORM. IF THE RIP RAP HAS BEEN DISPLACED, UNDERMINED OR DAMAGED, IT SHOULD BE REPAIRED IMMEDIATELY. THE CHANNEL IMMEDIATELY BELOW THE OUTLET SHOULD BE CHECKED TO SEE THAT EROSION IS NOT OCCURRING. THE DOWNSTREAM CHANNEL SHOULD BE KEPT CLEAR OF OBSTRUCTIONS SUCH AS FALLEN TREES, DEBRIS, AND SEDIMENT THAT COULD CHANGE FLOW PATTERNS AND/OR TAILWATER DEPTHS ON THE PIPES. REPAIRS MUST BE CARRIED OUT IMMEDIATELY TO AVOID ADDITIONAL DAMAGE TO OUTLET PROTECTION.

RIP RAP OUTLET PROTECTION APRON

NOT TO SCALE

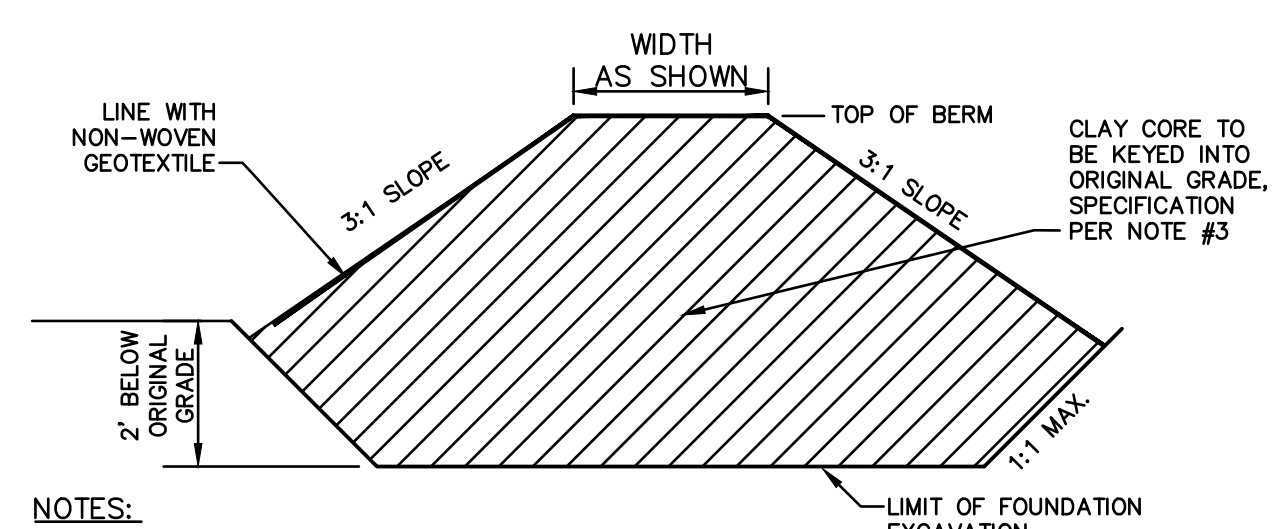

NOTES:

- BERM SHALL BE CONSTRUCTED WITH A CLAY CORE TO BE KEYED INTO ORIGINAL GRADE, AS WELL AS A FINE GEOTEXTILE, TO AVOID WATER SEEPAGE AND SOIL PIPING THROUGH THE EARTHEN DIVIDER
- THE ENTIRE EMBANKMENT AREA OF THE BIORETENTION AREA SHALL BE EXCAVATED A MINIMUM 2' BELOW THE ORIGINAL GRADE, STRIPPED OF ALL ORGANIC MATERIALS, COMPACTED TO AT LEAST 92% OF ASTM D-1557, AND SCARIFIED PRIOR TO THE PLACEMENT OF THE EMBANKMENT MATERIAL. PLACEMENT AND COMPACTION SHOULD OCCUR AT A MOISTURE CONTENT OF OPTIMUM PLUS OR MINUS 3%, AND NO FROZEN OR ORGANIC MATERIAL SHALL BE PLACED FOR ANY REASON.
- CLAY CORE MATERIAL SHALL BE CLEAN SILTY-CLAY BORROW FREE OF ROOTS, ORGANIC MATTER, AND OTHER DELETERIOUS SUBSTANCES, AND SHALL CONTAIN NO ROCKS OR LUMPS OVER THREE INCHES (3") IN DIAMETER. THIS MATERIAL SHALL BE INSTALLED IN 6" LIFTS COMPACTED TO 92% OF ASTM D-1557, AND SHALL MEET THE FOLLOWING SPECIFICATIONS: 6" PASSING 100%, #4 SIEVE 95-100%, #40 SIEVE 60-90%, #100 SIEVE 40-60%, #200 SIEVE 25-45% (OF THE FRACTION PASSING THE #4 SIEVE). THE CLAY COMPONENT SHALL HAVE A PLASTICITY INDEX OF AT LEAST 8 AND A HYDRAULIC CONDUCTIVITY OF 10 TO THE -6 CM/SEC.
- COMPACTION AND MATERIALS TESTING SERVICES SHALL BE PERFORMED BY AN INDEPENDENT GEOTECHNICAL ENGINEER RETAINED BY THE OWNER.

CLAY CORE BERM

NOT TO SCALE

Design: DJM	Draft: KDR	Date: 2/26/2024
Checked: JAC	Scale: AS NOTED	Project No.: 18134.1
Drawing Name: 18134.1-PLAN.dwg		
THIS PLAN SHALL NOT BE MODIFIED WITHOUT WRITTEN PERMISSION FROM JONES & BEACH ENGINEERS, INC. (JBE). ANY ALTERATIONS, AUTHORIZED OR OTHERWISE, SHALL BE AT THE USER'S SOLE RISK AND WITHOUT LIABILITY TO JBE.		

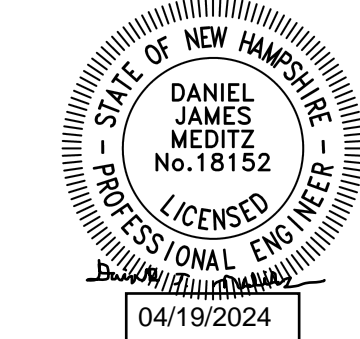

REV.	DATE	REVISION	BY
1	4/19/24	REVISED PER TAC COMMENTS	DJM
0	3/18/24	ISSUED FOR REVIEW	KDR
REV.	DATE	REVISION	BY

Designed and Produced in NH

J/B Jones & Beach Engineers, Inc.

85 Portsmouth Ave. PO Box 219 Stratham, NH 03885

Civil Engineering Services

603-772-4746

E-MAIL: JBE@JONESANDBEACH.COM

Plan Name:	DETAIL SHEET
Project:	LUSTER CLUSTER 635 SAGAMORE AVE., PORTSMOUTH, NH
Owner of Record:	635 SAGAMORE DEVELOPMENT LLC 3612 LAFAYETTE RD., DEPT 4, PORTSMOUTH, NH 03801 BK 6332 PG 1158

DRAWING No.

D4

SHEET 18 OF 20
JBE PROJECT NO. 18134.1

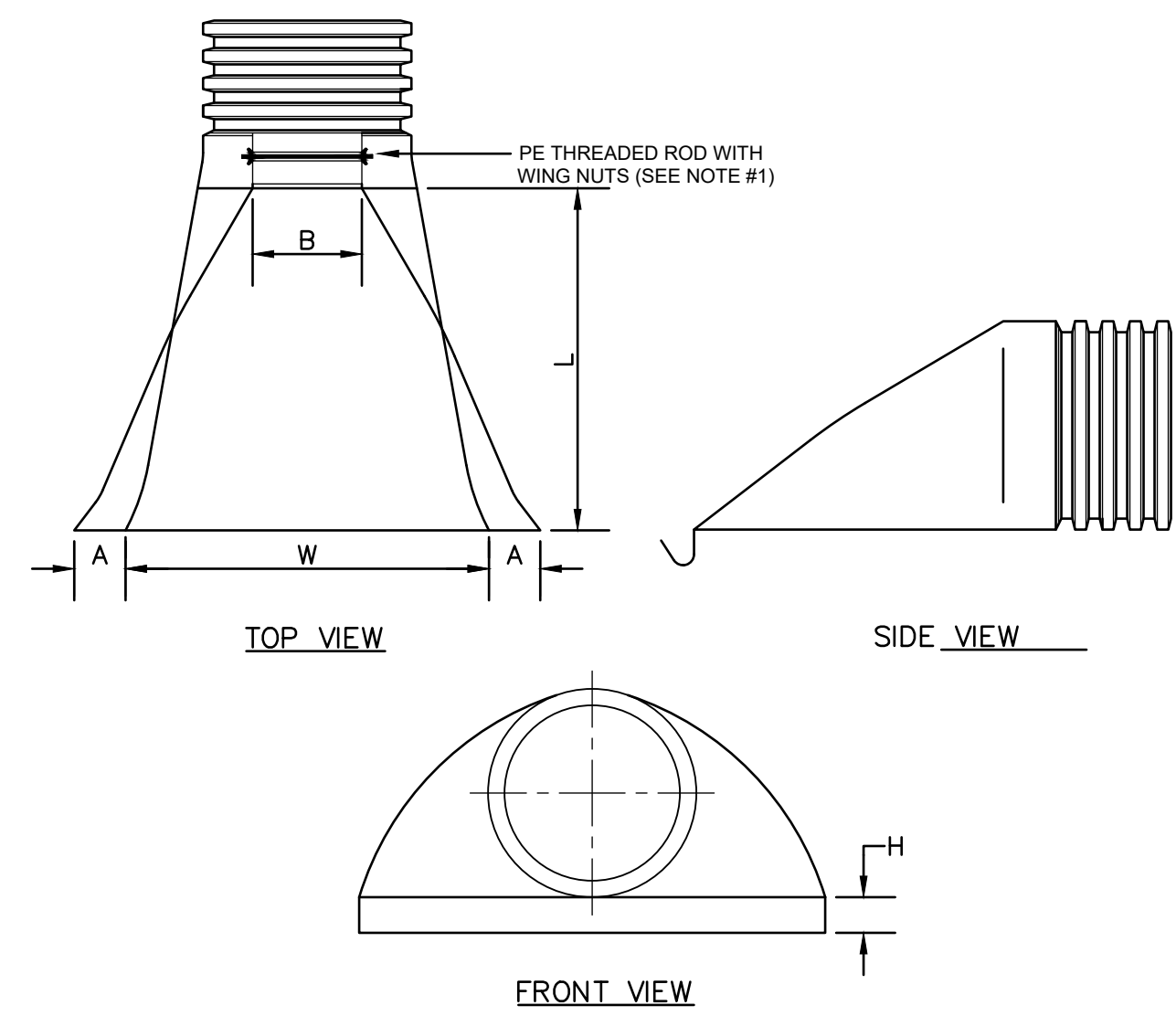
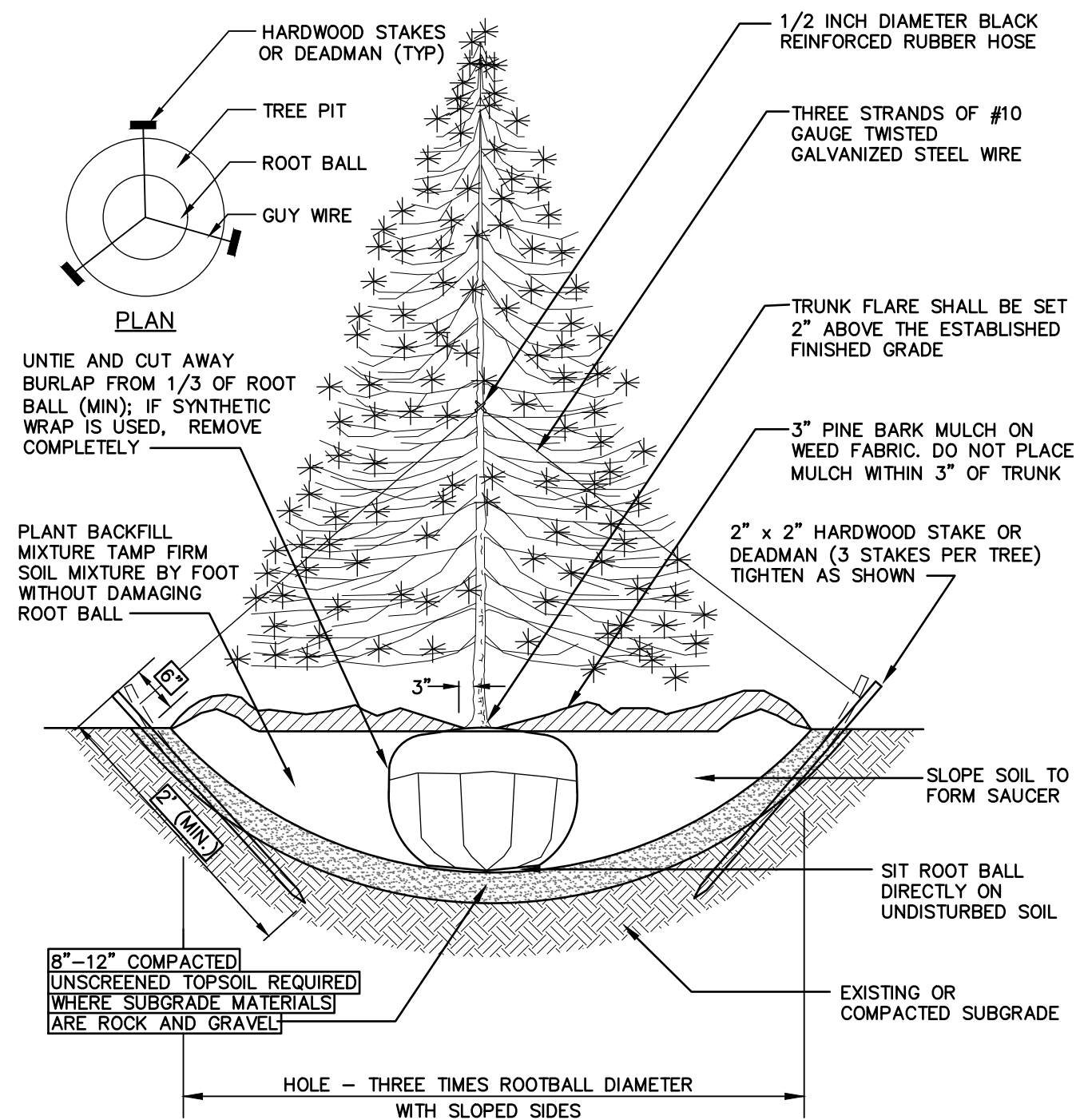

PART NO.	PIPE SIZE	A	B (MAX)	H	L	W
1210-NP	12"	6.5"	10"	6.5"	25"	29"
1510-NP	15"	6.5"	10"	6.5"	25"	29"
1810-NP	18"	7.5"	15"	6.5"	32"	35"
2410-NP	24"	7.5"	18"	6.5"	36"	45"
3010-NP	30"	10.5"	N/A	7.0"	53"	68"
3610-NP	36"	10.5"	N/A	7.0"	53"	68"

NOTES:

- PE THREADED ROD WITH WING NUTS PROVIDED FOR END SECTIONS 12"-24". 30" AND 36" END SECTIONS TO BE WELDED PER MANUFACTURER'S RECOMMENDATIONS.
- ALL DIMENSIONS ARE NOMINAL.

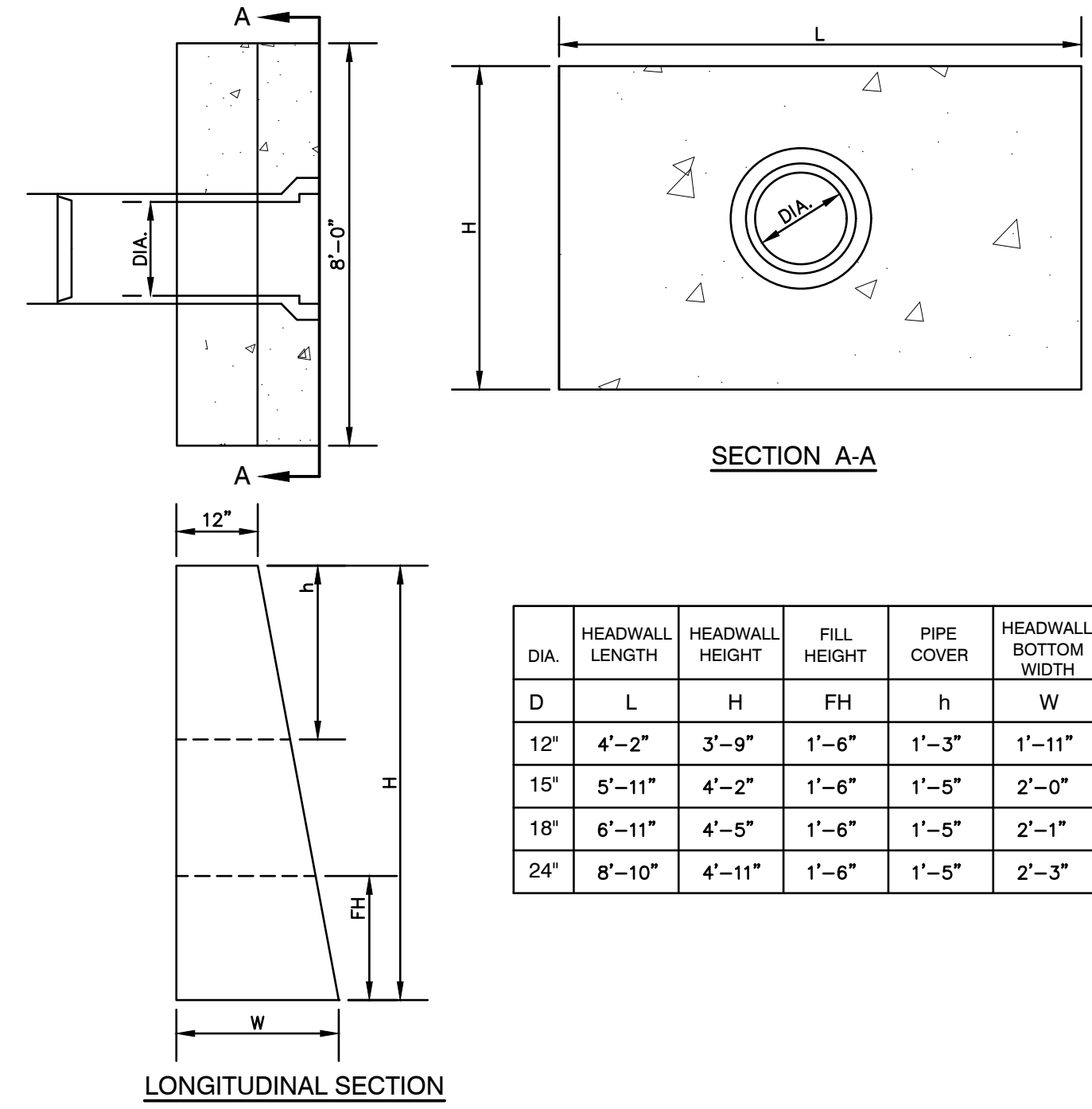
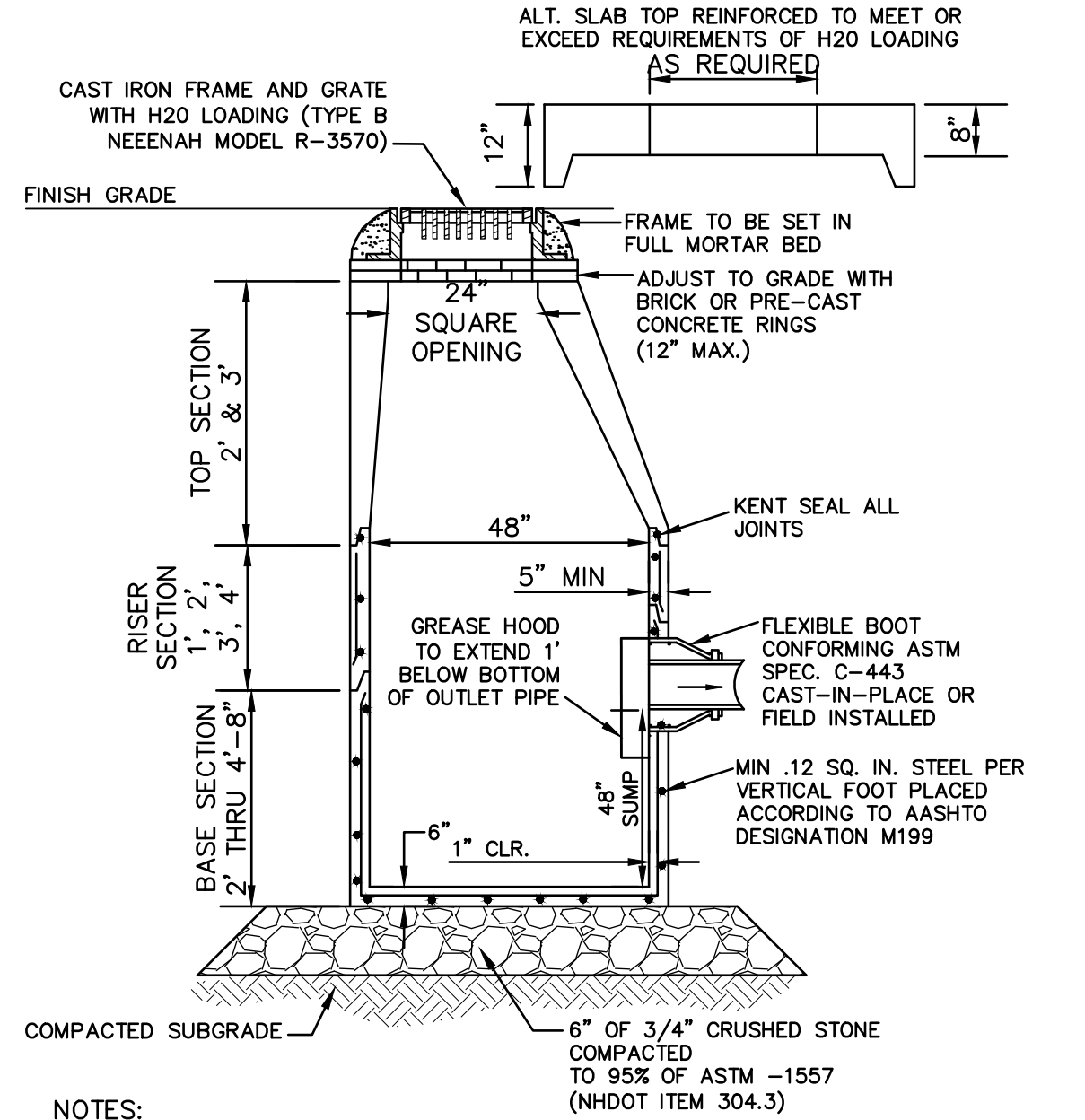
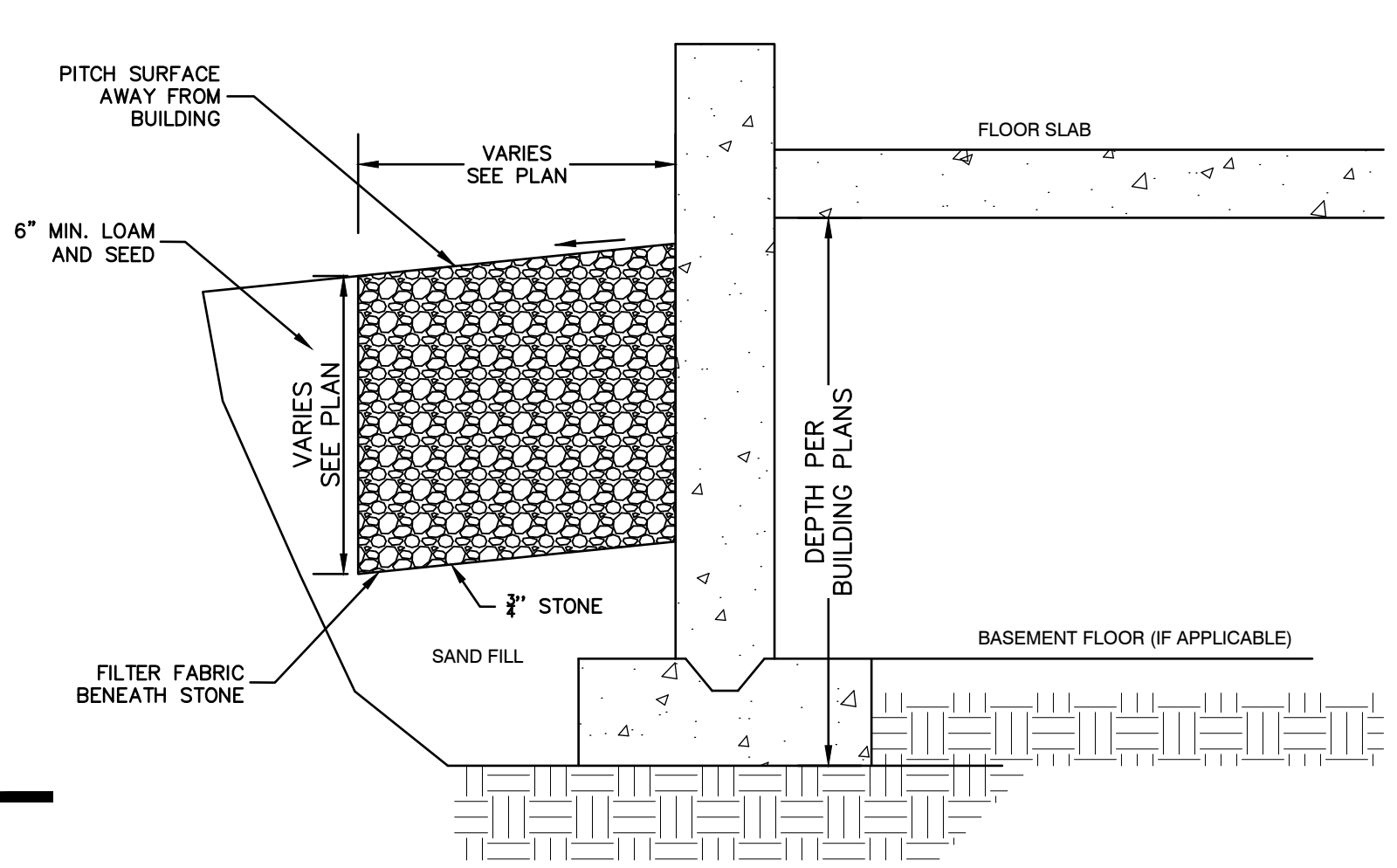
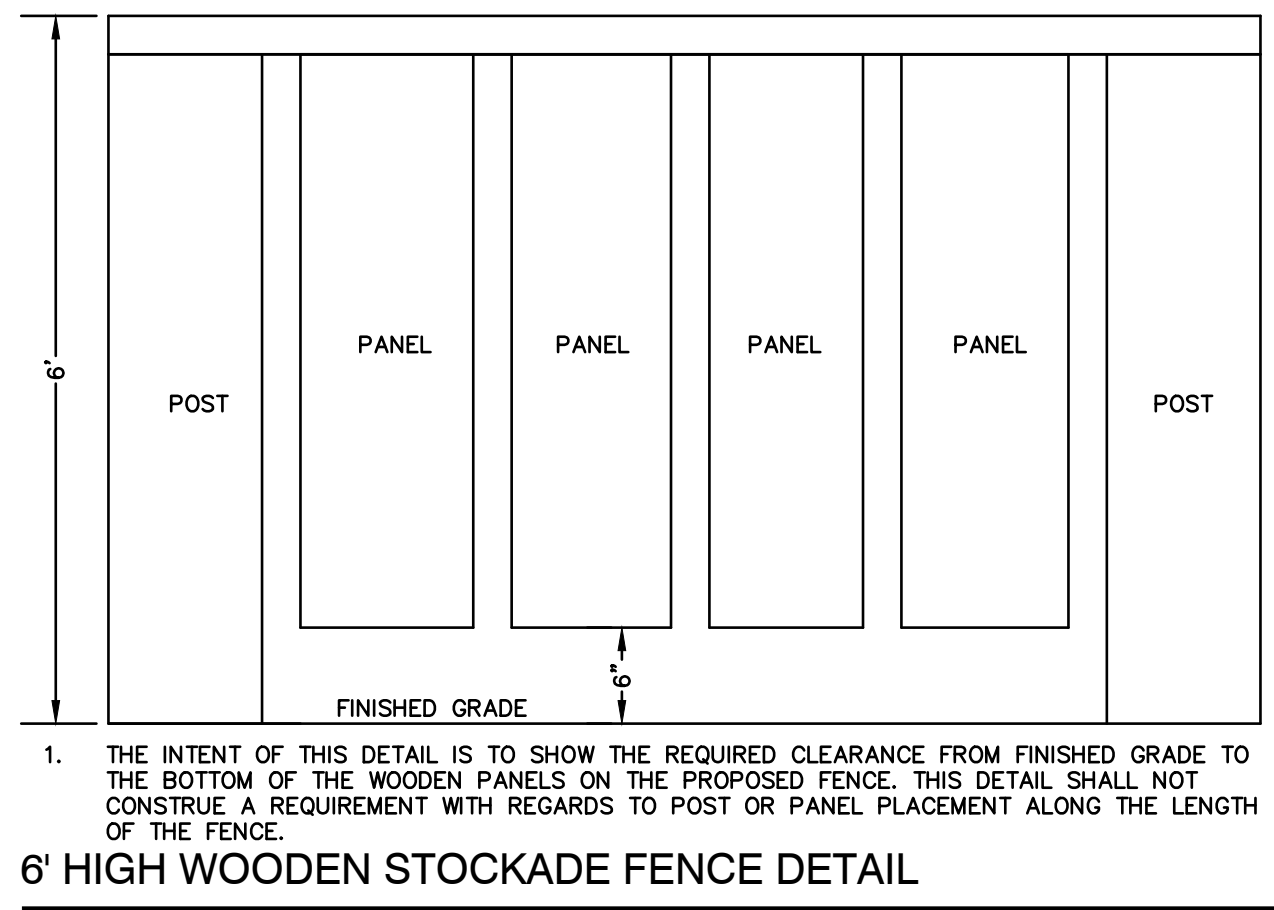
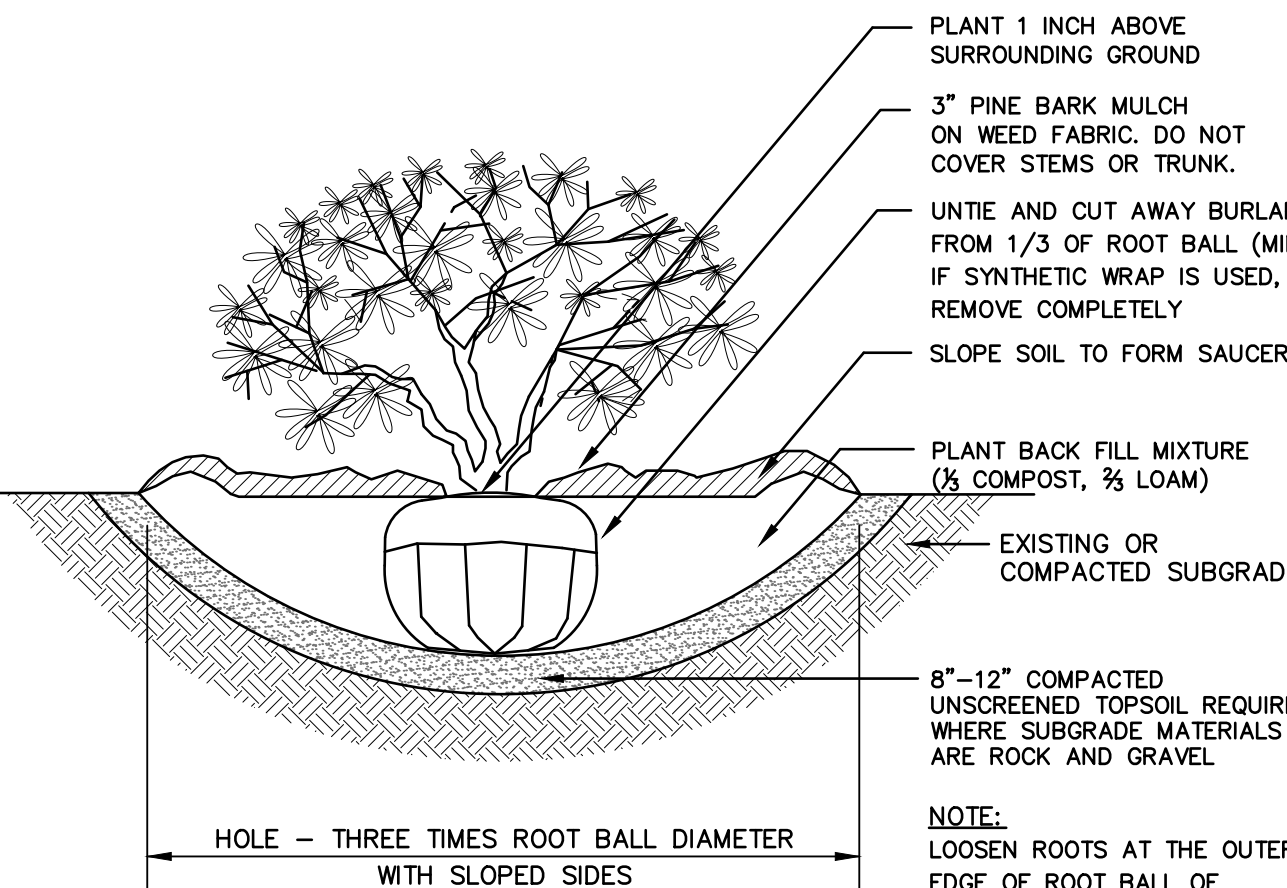
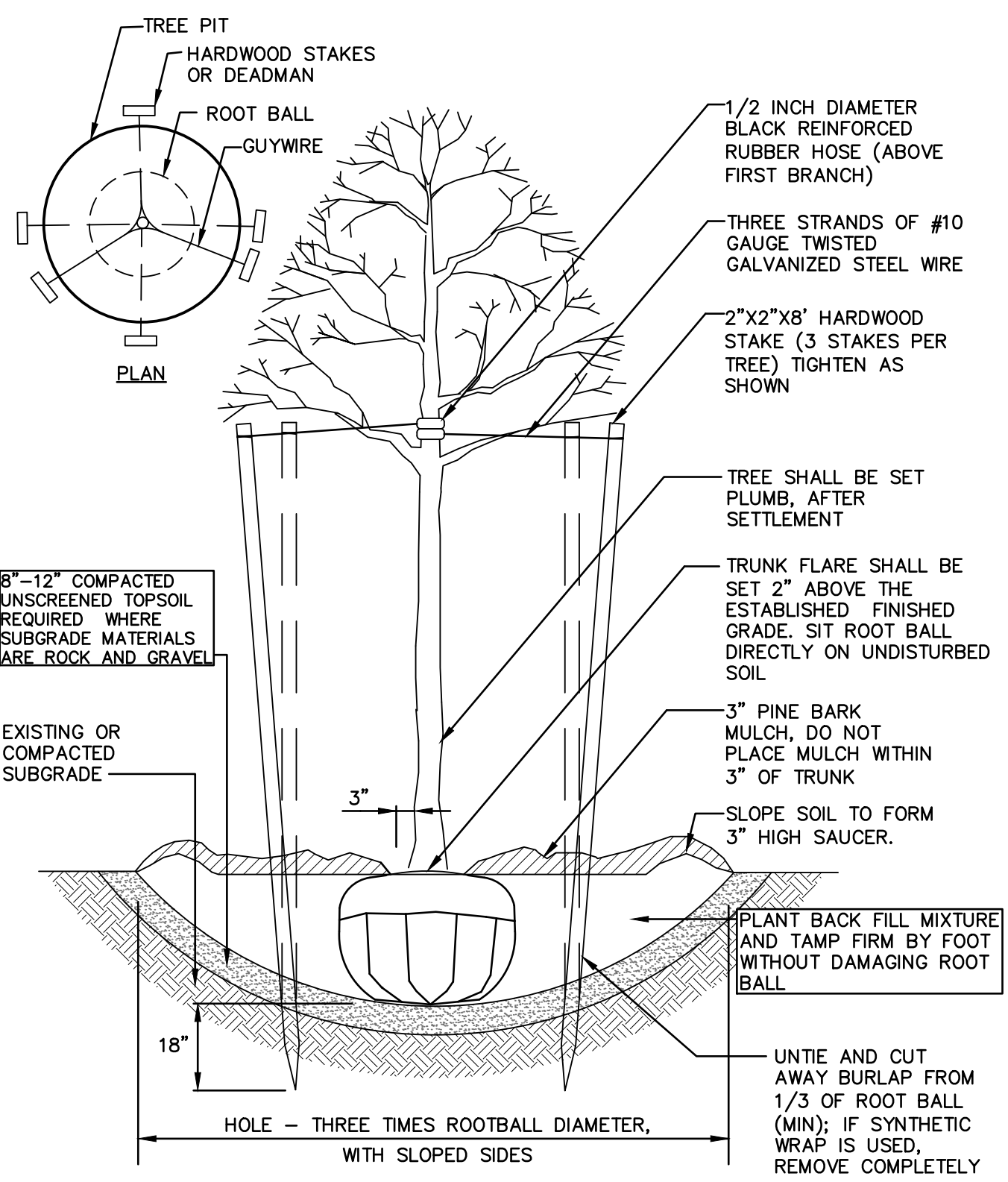

NOTES:

- BASE SECTION SHALL BE MONOLITHIC WITH 48" INSIDE DIAMETER.
- ALL SECTIONS SHALL BE DESIGNED FOR H2O LOADING.
- CONCRETE SHALL BE COMPRESSIVE STRENGTH 4000 PSI, TYPE II CEMENT.
- FRAMES AND GRATES SHALL BE HEAVY DUTY AND DESIGNED FOR H2O LOADING.
- PROVIDE "V" KNOCKOUTS FOR PIPES WITH 2" MAX. CLEARANCE TO OUTSIDE OF PIPE. MORTAR ALL PIPE CONNECTIONS SO AS TO BE WATERTIGHT.
- JOINT SEALANT BETWEEN PRECAST SECTIONS SHALL BE BUTYL RUBBER.
- STANDARD CATCH BASIN FRAME AND GRATE(S) SHALL BE SET IN FULL MORTAR BED. ADJUST TO GRADE WITH CLAY BRICK AND MORTAR (2 BRICK COURSES TYPICALLY, 5 BRICK COURSES MAXIMUM, BUT NO MORE THAN 12"), OR PRECAST CONCRETE "DONUTS".
- CATCH BASINS SHALL HAVE A 48" SUMP AS SHOWN.

NOTES:

- ALL DIMENSIONS GIVEN IN FEET & INCHES.
- PROVIDE BELL END AT INLET HEADWALL, AND SPIGOT END AT OUTLET END HEADWALL.
- CONCRETE: 5,000 PSI MINIMUM AFTER 28 DAYS. CEMENT TO BE TYPE III PER ASTM C-150. REINFORCING TO MEET OR EXCEED ASTM A-615 GRADE 60 DEFORMED BARS.
- 1" THREADED INSERTS PROVIDED FOR FINAL ATTACHMENT IN FIELD BY OTHERS.

Design: DJM Draft: KDR Date: 2/26/2024
 Checked: JAC Scale: AS NOTED Project No.: 18134.1
 Drawing Name: 18134.1-PLAN.dwg
 THIS PLAN SHALL NOT BE MODIFIED WITHOUT WRITTEN PERMISSION FROM JONES & BEACH ENGINEERS, INC. (JBE). ANY ALTERATIONS, AUTHORIZED OR OTHERWISE, SHALL BE AT THE USER'S SOLE RISK AND WITHOUT LIABILITY TO JBE.

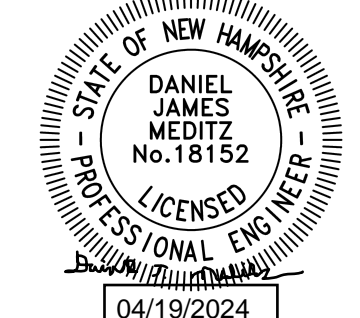

REV.	DATE	REVISION	BY
1	4/19/24	REVISED PER TAC COMMENTS	DJM
0	3/18/24	ISSUED FOR REVIEW	KDR

Designed and Produced in NH

J/B Jones & Beach Engineers, Inc.

85 Portsmouth Ave. PO Box 219 Stratham, NH 03885

Civil Engineering Services 603-772-4746

E-MAIL: JBE@JONESANDBEACH.COM

Plan Name: **DETAIL SHEET**

Project: **LUSTER CLUSTER**
635 SAGAMORE AVE., PORTSMOUTH, NH

Owner of Record: **635 SAGAMORE DEVELOPMENT LLC**
3612 LAFAYETTE RD., DEPT 4, PORTSMOUTH, NH 03801 BK 6332 PG 1158

DRAWING No. **D5**

SHEET 19 OF 20
 JBE PROJECT NO. 18134.1

TEMPORARY EROSION CONTROL NOTES

- THE SMALLEST PRACTICAL AREA OF LAND SHALL BE EXPOSED AT ANY ONE TIME. AT NO TIME SHALL AN AREA IN EXCESS OF 5 ACRES BE EXPOSED AT ANY ONE TIME BEFORE DISTURBED AREAS ARE STABILIZED.
- EROSION, SEDIMENT AND DETENTION MEASURES SHALL BE INSTALLED AS SHOWN ON THE PLANS AND AT LOCATIONS AS REQUIRED, DIRECTED BY THE ENGINEER.
- ALL DISTURBED AREAS (INCLUDING POND AREAS BELOW THE PROPOSED WATERLINE) SHALL BE RETURNED TO PROPOSED GRADES AND ELEVATIONS. DISTURBED AREAS SHALL BE LOAMED WITH A MINIMUM OF 6" OF SCREENED ORGANIC LOAM AND SEEDED WITH SEED MIXTURE 'C' AT A RATE NOT LESS THAN 1.10 POUNDS OF SEED PER 1,000 S.F. OF AREA (48 LBS. / ACRE).
- SILT FENCES AND OTHER BARRIERS SHALL BE INSPECTED EVERY SEVEN CALENDAR DAYS AND WITHIN 24 HOURS OF A RAINFALL OF 0.5" OR GREATER. ALL DAMAGED AREAS SHALL BE REPAIRED, AND SEDIMENT DEPOSITS SHALL PERIODICALLY BE REMOVED AND DISPOSED OF.
- AFTER ALL DISTURBED AREAS HAVE BEEN STABILIZED, THE TEMPORARY EROSION CONTROL MEASURES SHALL BE REMOVED AND THE AREA DISTURBED BY THE REMOVAL SMOOTHED AND RE-VEGETATED.
- AREAS MUST BE SEEDED AND MULCHED OR OTHERWISE PERMANENTLY STABILIZED WITHIN 3 DAYS OF FINAL GRADING, OR TEMPORARILY STABILIZED WITHIN 14 DAYS OF THE INITIAL DISTURBANCE OF SOIL. ALL AREAS SHALL BE STABILIZED WITHIN 45 DAYS OF INITIAL DISTURBANCE.
- ALL PROPOSED VEGETATED AREAS THAT DO NOT EXHIBIT A MINIMUM OF 85 PERCENT VEGETATIVE GROWTH BY OCTOBER 15, OR WHICH ARE DISTURBED AFTER OCTOBER 15, SHALL BE STABILIZED BY SEEDING AND INSTALLING NORTH AMERICAN GREEN S75 EROSION CONTROL BLANKETS (OR AN EQUIVALENT APPROVED IN WRITING BY THE ENGINEER) ON SLOPES GREATER THAN 3:1, AND SEEDING AND PLACING 3 TO 4 TONS OF MULCH PER ACRE, SECURED WITH ANCHORED NETTING, ELSEWHERE. THE INSTALLATION OF EROSION CONTROL BLANKETS OR MULCH AND NETTING SHALL NOT OCCUR OVER ACCUMULATED SNOW OR FROZEN GROUND AND SHALL BE COMPLETED IN ADVANCE OF THAW OR SPRING MELT EVENTS.
- ALL DITCHES OR SWALES WHICH DO NOT EXHIBIT A MINIMUM OF 85 PERCENT VEGETATIVE GROWTH BY OCTOBER 15, OR WHICH ARE DISTURBED AFTER OCTOBER 15, SHALL BE STABILIZED TEMPORARILY WITH STONE OR EROSION CONTROL BLANKETS APPROPRIATE FOR THE DESIGN FLOW CONDITIONS.
- AFTER OCTOBER 15th, INCOMPLETE ROAD OR PARKING SURFACES, WHERE WORK HAS STOPPED FOR THE WINTER SEASON, SHALL BE PROTECTED WITH A MINIMUM OF 3" OF CRUSHED GRAVEL PER NHDOT ITEM 304.3.
- AN AREA SHALL BE CONSIDERED STABLE IF ONE OF THE FOLLOWING HAS OCCURRED:
 - BASE COURSE GRAVELS HAVE BEEN INSTALLED IN AREAS TO BE PAVED;
 - A MINIMUM OF 85% VEGETATED GROWTH HAS BEEN ESTABLISHED;
 - A MINIMUM OF 3" OF NON-EROSIVE MATERIAL SUCH STONE OR RIPRAP HAS BEEN INSTALLED; OR
 - EROSION CONTROL BLANKETS HAVE BEEN PROPERLY INSTALLED.
- FUGITIVE DUST CONTROL IS REQUIRED TO BE CONTROLLED IN ACCORDANCE WITH ENV-A 1000, AND THE PROJECT IS TO MEET THE REQUIREMENTS AND INTENT OF RSA 430:53 AND AGR 3800 RELATIVE TO INVASIVE SPECIES.

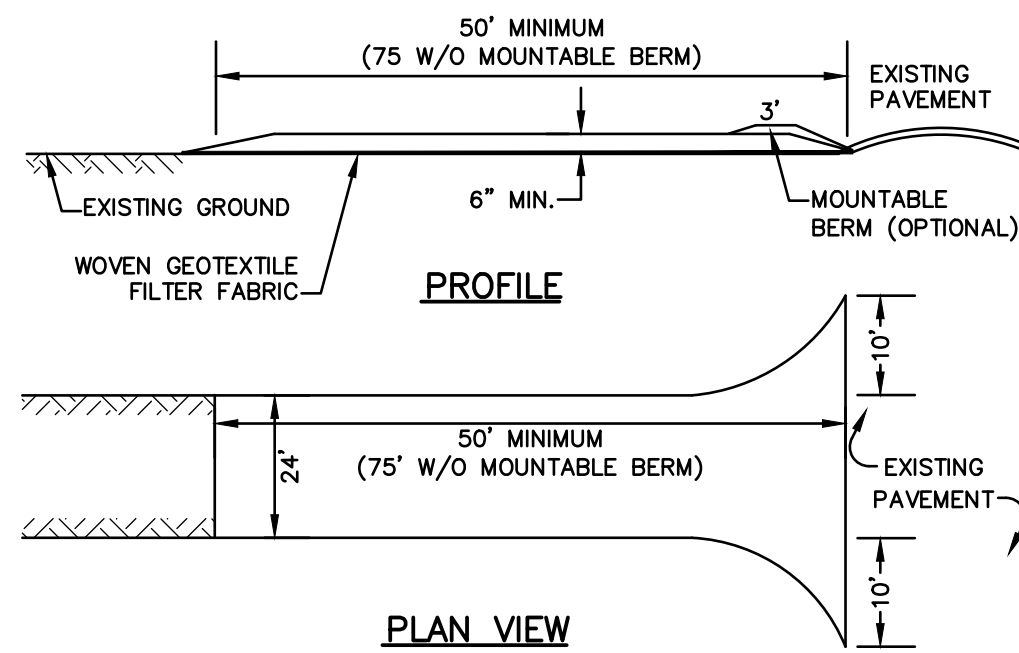

NOTES:

- STONE FOR STABILIZED CONSTRUCTION ENTRANCE SHALL BE 3 INCH STONE, RECLAIMED STONE, OR RECYCLED CONCRETE EQUIVALENT.
- THE LENGTH OF THE STABILIZED ENTRANCE SHALL NOT BE LESS THAN 50 FEET, 75' WITHOUT A MOUNTABLE BERM, AND EXCEPT FOR A SINGLE RESIDENTIAL LOT WHERE A 30 FOOT MINIMUM LENGTH WOULD APPLY.
- THICKNESS OF THE STONE FOR THE STABILIZED ENTRANCE SHALL NOT BE LESS THAN 6 INCHES.
- THE WIDTH OF THE ENTRANCE SHALL NOT BE LESS THAN THE FULL WIDTH OF THE ENTRANCE WHERE INGRESS OR EGRESS OCCURS, OR 10 FEET, WHICHEVER IS GREATER.
- GEOTEXTILE FILTER FABRIC SHALL BE PLACED OVER THE ENTIRE AREA PRIOR TO PLACING THE STONE. FILTER FABRIC IS NOT REQUIRED FOR A SINGLE FAMILY RESIDENTIAL LOT.
- ALL SURFACE WATER THAT IS FLOWING TO OR DIVERTED TOWARD THE CONSTRUCTION ENTRANCE SHALL BE PIPED BENEATH THE ENTRANCE. IF PIPING IS IMPRACTICAL, A STONE BERM WITH 5:1 SLOPES THAT CAN BE CROSSED BY VEHICLES MAY BE SUBSTITUTED FOR THE PIPE.
- THE ENTRANCE SHALL BE MAINTAINED IN A CONDITION THAT WILL PREVENT TRACKING OR FLOWING OF SEDIMENT ONTO THE PUBLIC RIGHT-OF-WAY. THIS MAY REQUIRE PERIODIC TOP DRESSING WITH ADDITIONAL STONE AS CONDITIONS DEMAND AND REPAIR AND/OR CLEAN OUT OF ANY MEASURES USED TO TRAP SEDIMENT. ALL SEDIMENT SPILLED, WASHED, OR TRACKED ONTO THE PUBLIC RIGHT-OF-WAY MUST BE REMOVED PROMPTLY.

STABILIZED CONSTRUCTION ENTRANCE

NOT TO SCALE

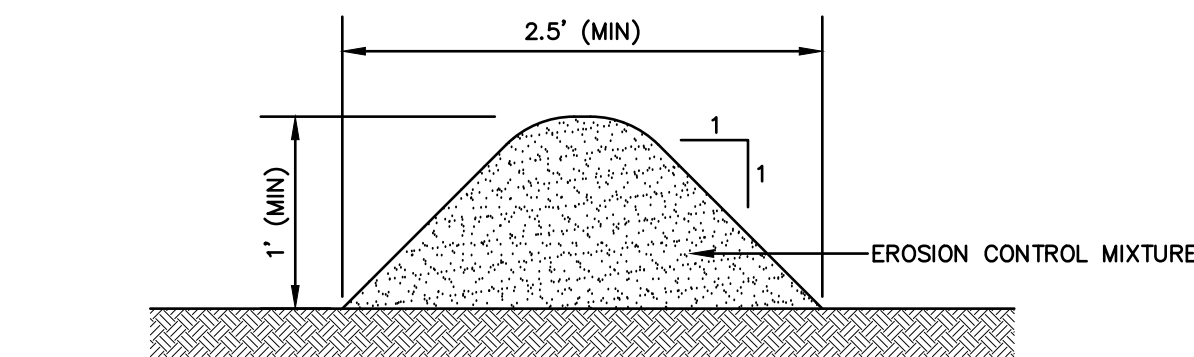

NOTES:

- ORGANIC FILTER BERMS SHALL BE UTILIZED IN LIEU OF SILT FENCE.
- THE EROSION CONTROL MIX USED IN THE FILTER BERMS SHALL BE A WELL-GRADED MIXTURE OF PARTICLE SIZES, MAY CONTAIN ROCKS LESS THAN 4" IN DIAMETER, STUMP GRINDINGS, SHREDDED OR COMPOSTED BARK, OR ACCEPTABLE MANUFACTURED PRODUCTS, AND SHALL BE FREE OF REFUSE, PHYSICAL CONTAMINANTS, AND MATERIAL TOXIC TO PLANT GROWTH, AND SHALL MEET THE FOLLOWING STANDARDS:
 - THE ORGANIC CONTENT SHALL BE 25-65% OF DRY WEIGHT.
 - PARTICLE SIZE BY WEIGHT SHALL BE 100% PASSING A 3" SCREEN, 90-100% PASSING A 1" SCREEN, 70-100% PASSING A 0.75" SCREEN, AND 30-75% PASSING A 0.25" SCREEN.
 - THE ORGANIC PORTION SHALL BE FIBROUS AND ELONGATED.
 - LARGE PORTIONS OF SILTS, CLAYS, OR FINE SANDS SHALL NOT BE INCLUDED IN THE MIXTURE.
 - SOLUBLE SALTS CONTENT SHALL BE >4.0mmhos/cm.
 - THE pH SHALL BE BETWEEN 5.0 AND 8.0.
- ORGANIC FILTER BERMS SHALL BE INSTALLED ALONG A RELATIVELY LEVEL CONTOUR. IT MAY BE NECESSARY TO CUT TALL GRASSES OR WOODY VEGETATION TO AVOID CREATING VOIDS AND BRIDGES THAT WOULD ENABLE FINES TO WASH UNDER THE BERM.
- ON SLOPES LESS THAN 5%, OR AT THE BOTTOM OF SLOPES STEEPER THAN 3:1, UP TO 20' LONG, THE BERM SHALL BE A MINIMUM OF 12" HIGH (AS MEASURED ON THE UPHILL SIDE), AND A MINIMUM OF 36" WIDE. ON LONGER OR STEEPER SLOPES, THE BERM SHALL BE WIDER TO ACCOMMODATE THE POTENTIAL ADDITIONAL RUNOFF.
- FROZEN GROUND, OUTCROPS OF BEDROCK, AND VERY ROOTED FORESTED AREAS PRESENT THE MOST PRACTICAL AND EFFECTIVE LOCATIONS FOR ORGANIC FILTER BERMS. OTHER BMP'S SHOULD BE USED AT LOW POINTS OF CONCENTRATED RUNOFF, BELOW CULVERT OUTLET APRONS, AROUND CATCH BASINS, AND AT THE BOTTOM OF STEEP PERIMETER SLOPES THAT HAVE A LARGE CONTRIBUTING AREA.
- SEDIMENT SHALL BE REMOVED FROM BEHIND THE STRUCTURES WHEN IT HAS ACCUMULATED TO ONE HALF THE ORIGINAL HEIGHT OF THE STRUCTURE.
- STRUCTURES MAY BE LEFT IN PLACE ONCE THE SITE IS STABILIZED.

ORGANIC FILTER BERM / FIBER BERM

NOT TO SCALE

SEEDING SPECIFICATIONS

1. GRADING AND SHAPING

- SLOPES SHALL NOT BE STEEPER THAN 2:1 WITHOUT APPROPRIATE EROSION CONTROL MEASURES AS SPECIFIED ON THE PLANS (3:1 SLOPES OR FLATTER ARE PREFERRED).
- WHERE MOWING WILL BE DONE, 3:1 SLOPES OR FLATTER ARE RECOMMENDED.

2. SEEDBED PREPARATION

- SURFACE AND SEEPAGE WATER SHOULD BE DRAINED OR DIVERTED FROM THE SITE TO PREVENT DROWNING OR WINTER KILLING OF THE PLANTS.
- STONES LARGER THAN 4 INCHES AND TRASH SHOULD BE REMOVED BECAUSE THEY INTERFERE WITH SEEDING AND FUTURE MAINTENANCE OF THE AREA. WHERE FEASIBLE, THE SOIL SHOULD BE TILLED TO A DEPTH OF ABOUT 4 INCHES TO PREPARE A SEEDBED AND FERTILIZER AND LIME MIXED INTO THE SOIL. THE SEEDBED SHOULD BE LEFT IN A REASONABLY FIRM AND SMOOTH CONDITION. THE LAST TILLAGE OPERATION SHOULD BE PERFORMED ACROSS THE SLOPE WHEREVER PRACTICAL.

3. ESTABLISHING A STAND

- LIME AND FERTILIZER SHOULD BE APPLIED PRIOR TO OR AT THE TIME OF SEEDING AND INCORPORATED INTO THE SOIL. TYPES AND AMOUNTS OF LIME AND FERTILIZER SHOULD BE BASED ON AN EVALUATION OF SOIL TESTS. WHEN A SOIL TEST IS NOT AVAILABLE, THE FOLLOWING MINIMUM AMOUNTS SHOULD BE APPLIED:
 - AGRICULTURAL LIMESTONE, 2 TONS PER ACRE OR 100 LBS. PER 1,000 SQ.FT.
 - NITROGEN(N), 50 LBS. PER ACRE OR 1.1 LBS. PER 1,000 SQ.FT.
 - PHOSPHATE(P2O5), 100 LBS. PER ACRE OR 2.2 LBS. PER 1,000 SQ.FT.
 - POTASH(K2O), 100 LBS. PER ACRE OR 2.2 LBS. PER 1,000 SQ.FT.
 - (NOTE: THIS IS THE EQUIVALENT OF 500 LBS. PER ACRE OF 10-20-20 FERTILIZER OR 1,000 LBS. PER ACRE OF 5-10-10.)
 - SEED SHOULD BE SPREAD UNIFORMLY BY THE METHOD MOST APPROPRIATE FOR THE SITE. METHODS INCLUDE BROADCASTING, DRILLING AND HYDROSEEDING. WHERE BROADCASTING IS USED, COVER SEED WITH .25 INCH OF SOIL OR LESS, BY CULTIPACKING OR RAKING.
 - REFER TO THE 'SEEDING GUIDE' AND 'SEEDING RATES' TABLES ON THIS SHEET FOR APPROPRIATE SEED MIXTURES AND RATES OF SEEDING. ALL LEGUMES (CROWN VETCH, BIRDSFOOT, TREFOL AND FLATPEA) MUST BE INOCULATED WITH THEIR SPECIFIC INOCULANT PRIOR TO THEIR INTRODUCTION TO THE SITE.
 - WHEN SEEDING AREAS ARE MULCHED, PLANTINGS MAY BE MADE FROM EARLY SPRING TO EARLY OCTOBER. WHEN SEEDING AREAS ARE NOT MULCHED, PLANTINGS SHOULD BE MADE FROM EARLY SPRING TO MAY 20th OR FROM AUGUST 10th TO SEPTEMBER 1st.
- 4. MULCH**
- HAY, STRAW, OR OTHER MULCH, WHEN NEEDED, SHOULD BE APPLIED IMMEDIATELY AFTER SEEDING.
 - MULCH WILL BE HELD IN PLACE USING APPROPRIATE TECHNIQUES FROM THE BEST MANAGEMENT PRACTICE FOR MULCHING. HAY OR STRAW MULCH SHALL BE PLACED AT A RATE OF 90 LBS PER 1000 S.F.
- 5. MAINTENANCE TO ESTABLISH A STAND**
- PLANTED AREAS SHOULD BE PROTECTED FROM DAMAGE BY FIRE, GRAZING, TRAFFIC, AND DENSE WEED GROWTH.
 - FERTILIZATION NEEDS SHOULD BE DETERMINED BY ONSITE INSPECTIONS. SUPPLEMENTAL FERTILIZER IS USUALLY THE KEY TO FULLY COMPLETE THE ESTABLISHMENT OF THE STAND BECAUSE MOST PERENNIALS TAKE 2 TO 3 YEARS TO BECOME FULLY ESTABLISHED.
 - IN WATERWAYS, CHANNELS, OR SWALES WHERE UNIFORM FLOW CONDITIONS ARE ANTICIPATED, ANNUAL MOWING MAY BE NECESSARY TO CONTROL GROWTH OF WOODY VEGETATION.

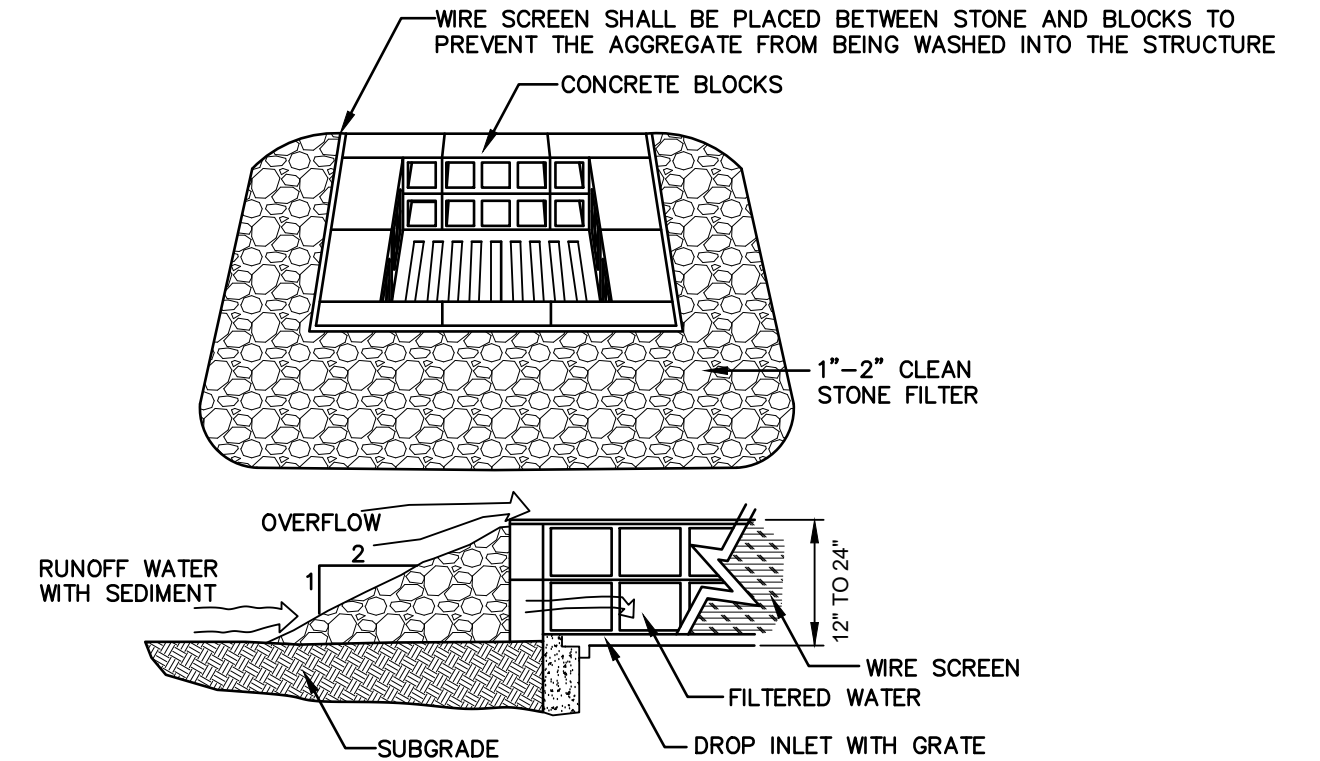

MAINTENANCE NOTE:

- ALL STRUCTURES SHOULD BE INSPECTED AFTER EVERY RAINFALL AND REPAIRS MADE AS NECESSARY. SEDIMENT SHOULD BE REMOVED FROM TRAPPING DEVICES AFTER THE SEDIMENT HAS REACHED A MAXIMUM OF ONE HALF THE DEPTH OF THE TRAP. THE SEDIMENT SHOULD BE DISPOSED IN A SUITABLE UPLAND AREA AND PROTECTED FROM EROSION BY EITHER STRUCTURE OR VEGETATIVE MEANS. THE TEMPORARY TRAPS SHOULD BE REMOVED AND THE AREA REPAIRED AS SOON AS THE CONTRIBUTING DRAINAGE AREA TO THE INLET HAS BEEN COMPLETELY STABILIZED.

TEMPORARY CATCH BASIN INLET PROTECTION (Block and Gravel Drop Inlet Sediment Filter)

NOT TO SCALE

USE	SEEDING MIXTURE 1/	DROUGHTY	WELL DRAINED	MODERATELY WELL DRAINED	POORLY DRAINED
STEEP CUTS AND FILLS, BORROW AND DISPOSAL AREAS	A	FAIR	GOOD	GOOD	FAIR
	B	POOR	GOOD	FAIR	FAIR
	C	POOR	GOOD	EXCELLENT	GOOD
	D	FAIR	EXCELLENT	EXCELLENT	POOR
WATERWAYS, EMERGENCY SPILLWAYS, AND OTHER CHANNELS WITH FLOWING WATER.	A	GOOD	GOOD	GOOD	FAIR
	C	GOOD	EXCELLENT	EXCELLENT	FAIR
LIGHTLY USED PARKING LOTS, OOD AREAS, UNUSED LANDS, AND LOW INTENSITY USE RECREATION SITES.	A	GOOD	GOOD	GOOD	FAIR
	B	GOOD	GOOD	FAIR	POOR
	C	GOOD	EXCELLENT	EXCELLENT	FAIR
PLAY AREAS AND ATHLETIC FIELDS. (TOPSOIL IS ESSENTIAL FOR GOOD TURF.)	E	FAIR	EXCELLENT	EXCELLENT	2/
	F	FAIR	EXCELLENT	EXCELLENT	2/
GRAVEL PIT, SEE NH-PM-24 IN APPENDIX FOR RECOMMENDATION REGARDING RECLAMATION OF SAND AND GRAVEL PITS.					
1/ REFER TO SEEDING MIXTURES AND RATES IN TABLE BELOW.					
2/ POORLY DRAINED SOILS ARE NOT DESIRABLE FOR USE AS PLAYING AREA AND ATHLETIC FIELDS.					

NOTE: TEMPORARY SEED MIX FOR STABILIZATION OF TURF SHALL BE WINTER RYE OR OATS AT A RATE OF 2.5 LBS. PER 1000 S.F. AND SHALL BE PLACED PRIOR TO OCTOBER 15th, IF PERMANENT SEEDING NOT YET COMPLETE.

SEEDING GUIDE

MIXTURE	POUNDS PER ACRE	POUNDS PER 1,000 Sq. Ft.
A. TALL FESCUE	20	0.45
CREeping RED FESCUE	20	0.45
RED TOP	2	0.05
TOTAL	42	0.95
B. TALL FESCUE	15	0.35
CREeping RED FESCUE	10	0.25
CROWN VETCH	15	0.35
OR FLAT PEA	30	0.75
TOTAL	40 OR 55	0.95 OR 1.35
* C. TALL FESCUE	20	0.45
CREeping RED FESCUE	20	0.45
BIRDS FOOT TREFOL	8	0.20
TOTAL	48	1.10
D. TALL FESCUE	20	0.45
FLAT PEA	30	0.75
TOTAL	50	1.20
E. CREeping RED FESCUE 1/	50	1.15
KENTUCKY BLUEGRASS 1/	50	1.15
TOTAL	100	2.30
F. TALL FESCUE 1	150	3.60

1/ FOR HEAVY USE ATHLETIC FIELDS CONSULT THE UNIVERSITY OF NEW HAMPSHIRE COOPERATIVE EXTENSION TURF SPECIALIST FOR CURRENT VARIETIES AND SEEDING RATES.

SEEDING RATES

Design: DJM	Draft: KDR	Date: 2/26/2024
Checked: JAC	Scale: AS NOTED	Project No.: 18134.1
Drawing Name: 18134.1-PLAN.dwg		
THIS PLAN SHALL NOT BE MODIFIED WITHOUT WRITTEN PERMISSION FROM JONES & BEACH ENGINEERS, INC. (JBE). ANY ALTERATIONS, AUTHORIZED OR OTHERWISE, SHALL BE AT THE USER'S SOLE RISK AND WITHOUT LIABILITY TO JBE.		

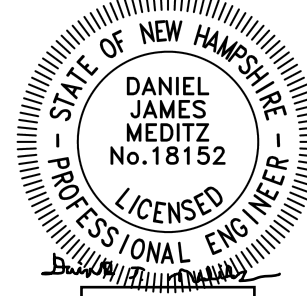

REV.	DATE	REVISION	BY
1	4/19/24	REVISED PER TAC COMMENTS	DJM
0	3/18/24	ISSUED FOR REVIEW	KDR
		REVISION	BY

Designed and Produced in NH

J/B Jones & Beach Engineers, Inc.

85 Portsmouth Ave. Civil Engineering Services 603-772-4746
 PO Box 219 Stratham, NH 03885 E-MAIL: JBE@JONESANDBEACH.COM

Plan Name:	EROSION AND SEDIMENT CONTROL DETAILS
Project:	LUSTER CLUSTER 635 SAGAMORE AVE., PORTSMOUTH, NH
Owner of Record:	635 SAGAMORE DEVELOPMENT LLC 3612 LAFAYETTE RD., DEPT 4, PORTSMOUTH, NH 03801 BK 6332 PG 1158

DRAWING No.	E1
SHEET 20 OF 20	JBE PROJECT NO. 18134.1



RIGHT SIDE ELEVATION
1/4" = 1'-0"



REAR ELEVATION
1/4" = 1'-0"



LEFT SIDE ELEVATION
1/4" = 1'-0"

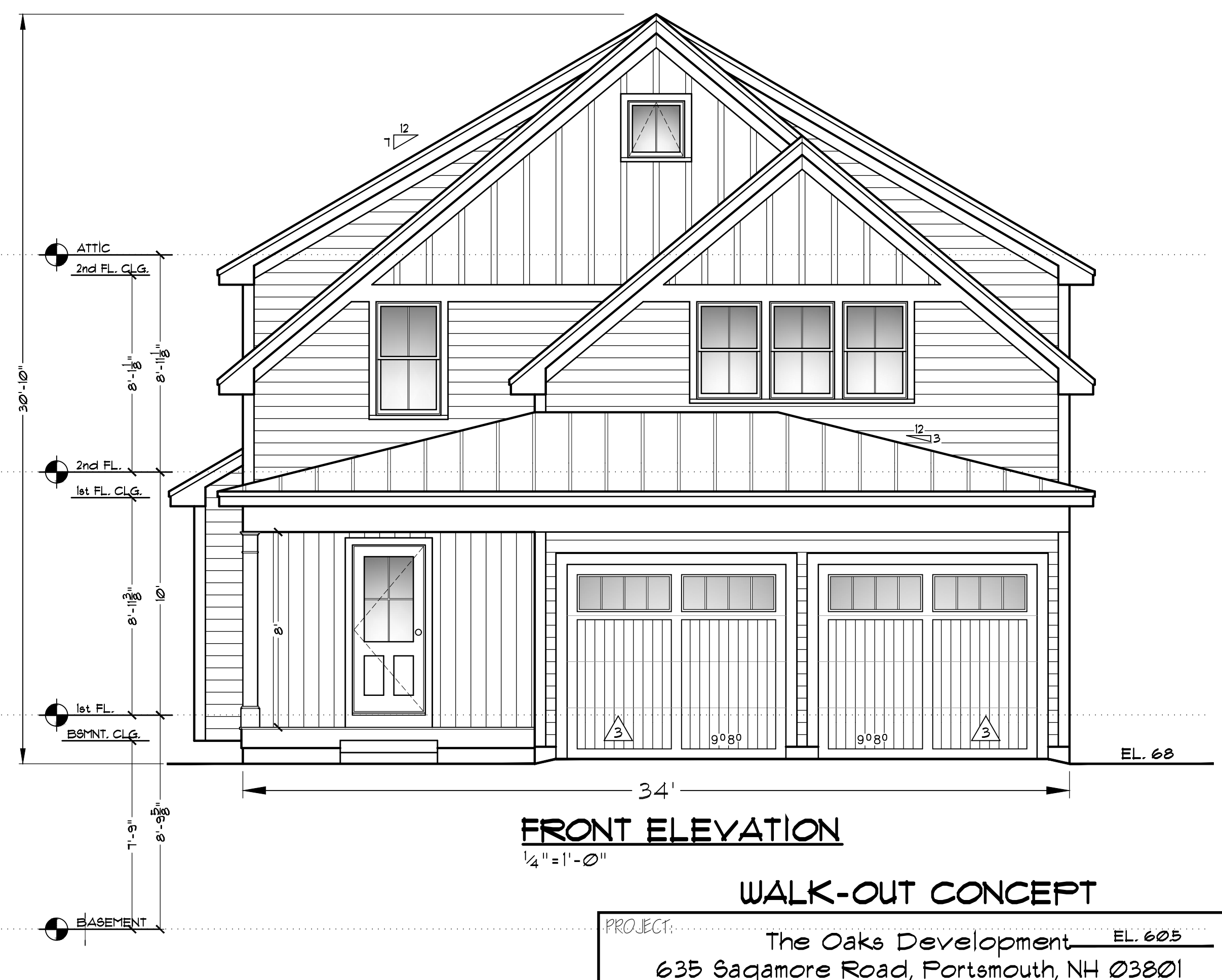

FRONT ELEVATION
1/4" = 1'-0"

WALK-OUT CONCEPT

PROJECT: The Oaks Development		EL. 605
635 Sagamore Road, Portsmouth, NH 03801		
E-mail: tech-112@comcast.net	Phone: 603-964-1300	DATE: 1-30-24
	Fax: 603-580-1414	REVISED:
Technical Illustrations		DWG. NO. 1
ARCHITECTURAL DRAFTING SERVICE		
186 Bunker Hill Ave.	Stratham, NH 03885	

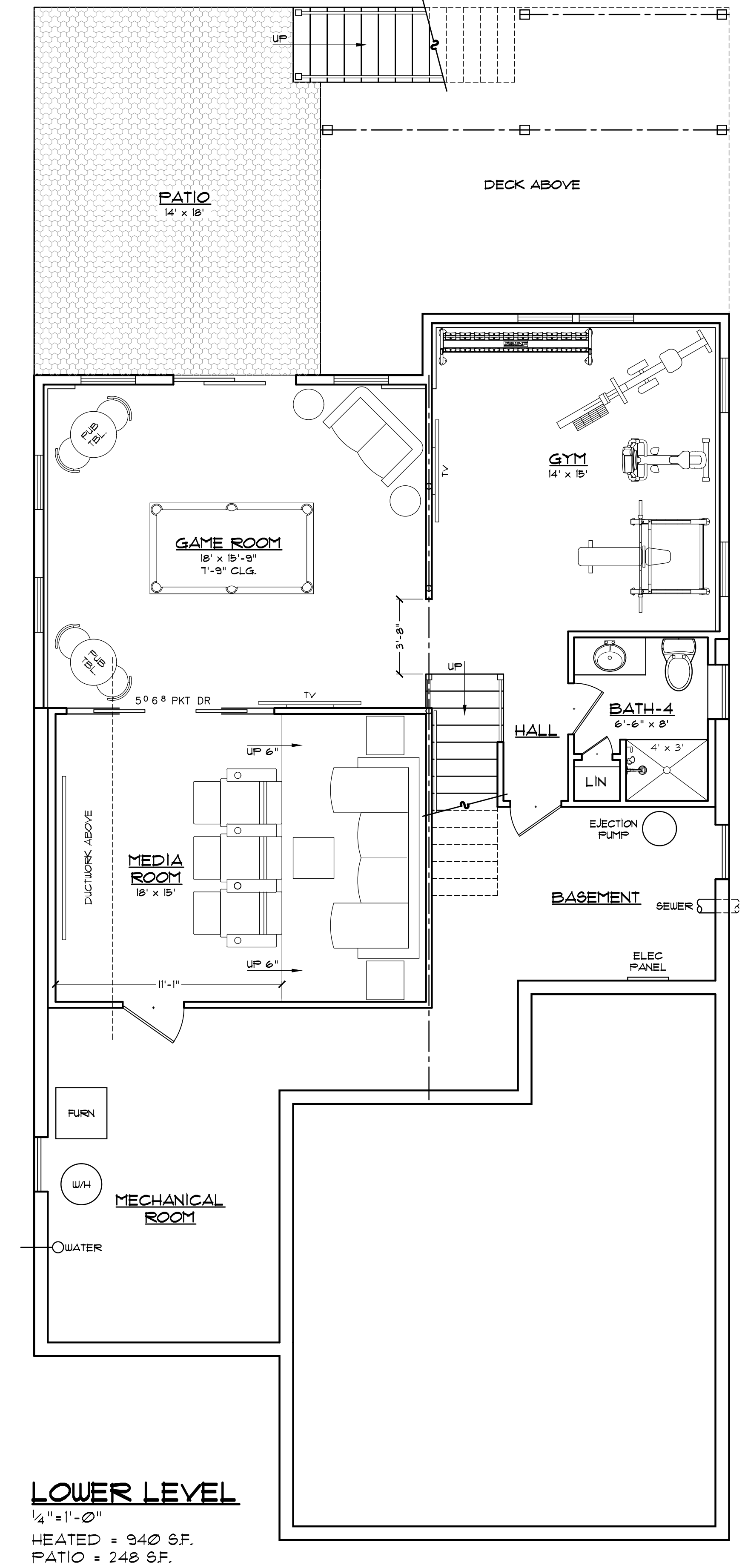
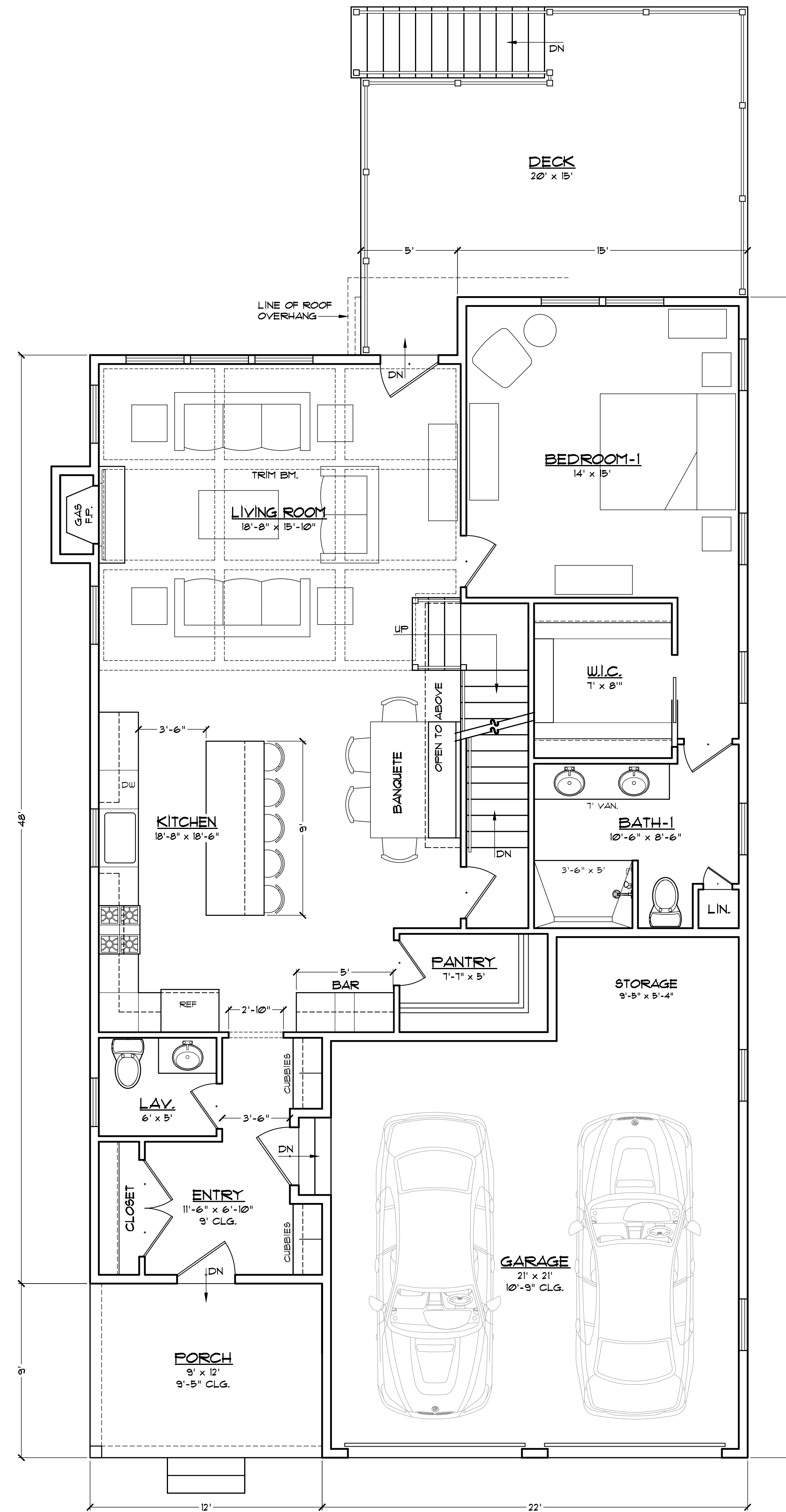
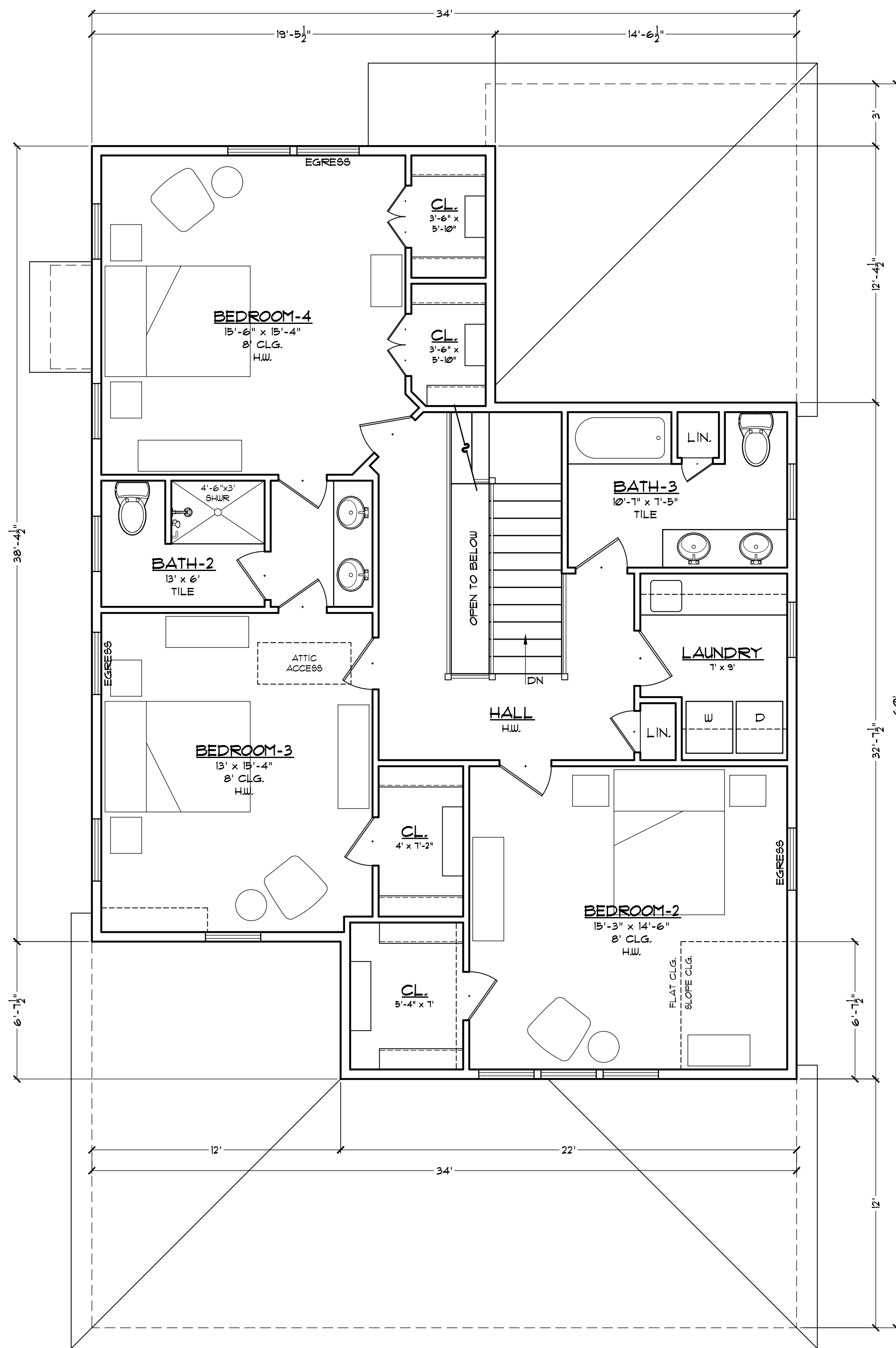

Finished basements and
walkouts on Units 3 & 4 only

WALK-OUT CONCEPT

PROJECT: The Oaks Development 635 Sagamore Road, Portsmouth, NH 03801		DATE: 1-30-24
E-mail: tech-112@comcast.net	Phone: 603-964-1300 Fax: 603-980-1414	REVISED:
Technical Illustrations ARCHITECTURAL DRAFTING SERVICE 196 Burker Hill Ave. Stratham, NH 03885		DWG. NO. 3