

**Civil
Site Planning
Environmental
Engineering**

133 Court Street
Portsmouth, NH
03801-4413

July 10, 2023

Peter Britz, Planning and Sustainability Director
City of Portsmouth Municipal Complex
1 Junkins Avenue
Portsmouth, New Hampshire 03801

**Re: Application for Lot Line Adjustment Subdivision Approval
Assessor's Map 223, Lots 18 and 18-1
27 Shaw Road and Walker Bungalow Road
Altus Project No. 5279**

Dear Peter,

On behalf of the Mary Duff (Bonnie) Kastel and Clyde Logue, Altus Engineering respectfully submits an application for Lot Line Adjustment and Subdivision. Bonnie and Clyde intended to complete a lot line adjustment with Lot 18-1 to create frontage on Walker Bungalow Road for the potential of a driveway to the proposed new lot created primarily from Lot 18.

An existing drainage easement that bisects Lot 18 will be relocated along the eastern boundary of the new lot to minimize the potential for impacts to the development area.

It is our intention to fully address the stormwater management required for the new lot so that we can incorporate appropriate measures to ensure that there are no downgradient impacts to abutting properties.

Enclosed please find the following items for consideration at the August 1st TAC Meeting:

- Letter of Authorization
- Subdivision Application Checklist
- Lot Line Adjustment and Subdivision Plans (JBE)
- Stormwater Management Plans (Altus)
- Drainage narrative

Please call or email me directly should you have any questions or need any additional information.

Sincerely,

A handwritten signature in black ink, appearing to read "B. Logue", written over a light blue horizontal line.

wde/5279.00 cvr ltr.docx

Enclosures

eCopy: Bonnie and Clyde Logue
Joe Coronati, JBE

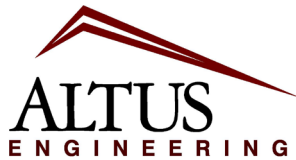

**Civil
Site Planning
Environmental
Engineering**

133 Court Street
Portsmouth, NH
03801-4413

**Revised Drainage Summary
For
27 Shaw Road
Portsmouth, NH**

Project Description

Bonnie and Clyde are owners of property identified as Assessor’s Map 223, Lot 18 & 18-1, located at 27 Shaw Road. They intended to complete a lot line adjustment with Lot 18-1 to create frontage on Walker Bungalow Road for a driveway to the proposed new lot created primarily from Lot 18.

Site conditions on Lot 18 will remain unchanged except for the removal of 319 square feet of paved driveway, thereby reducing the lot’s runoff. The grass underdrain soil filter (GUSF) on Lot 18-1 was reshaped to accommodate the revised lot configuration. The GUSF a larger infiltration bottom area and storage capacity than previously approved, thereby providing additional stormwater treatment and reducing runoff to the City’s closed drainage system.

It is our intention to fully address the stormwater management required for the new lot, so that we can incorporate appropriate measures to ensure that there are no downgradient impacts to abutting properties.

Drainage Analysis

A complete summary of the drainage model will be provided upon request. The following table compares pre- and post-development peak rates for the 2, 10, 25, and 50-year storm events associated with Lot 18-1 only:

Stormwater Modeling Summary Peak Q (cfs) for Type III 24-Hour Storm Events

*Rainfall Intensities Reflect 15% Increase per AoT	2-Yr Storm (3.69 inch)	10-Yr Storm (5.60 inch)	25-Yr Storm (7.10 inch)	50-Yr Storm (8.50 inch)
POA #1				
Pre	0.65	1.32	1.87	2.39
Post	0.06	0.59	1.36	2.18
Change	-0.59	-0.73	-0.51	-0.21

Conclusion

This proposed residential development off Shaw Road in Portsmouth, NH will have minimal adverse effect on abutting properties and infrastructure as a result of stormwater runoff or siltation. Post-construction peak rates of runoff from the site will be lower than the existing conditions for all analyzed storm events. The new stormwater management system will also provide appropriate treatment of runoff from the proposed impervious area. Appropriate steps will be taken to properly mitigate erosion and sedimentation using temporary and permanent Best Management Practices for sediment and erosion control, including vegetated swales and a raingarden.

5279.05 SWM.narrative.docx

PLAN REFERENCES:

1. "SUBDIVISION PLAN, TAX MAP 223 LOT 18," DATED AUGUST 31, 2022. PREPARED BY JONES & BEACH ENGINEERS, INC. R.C.R.D. D-43498.

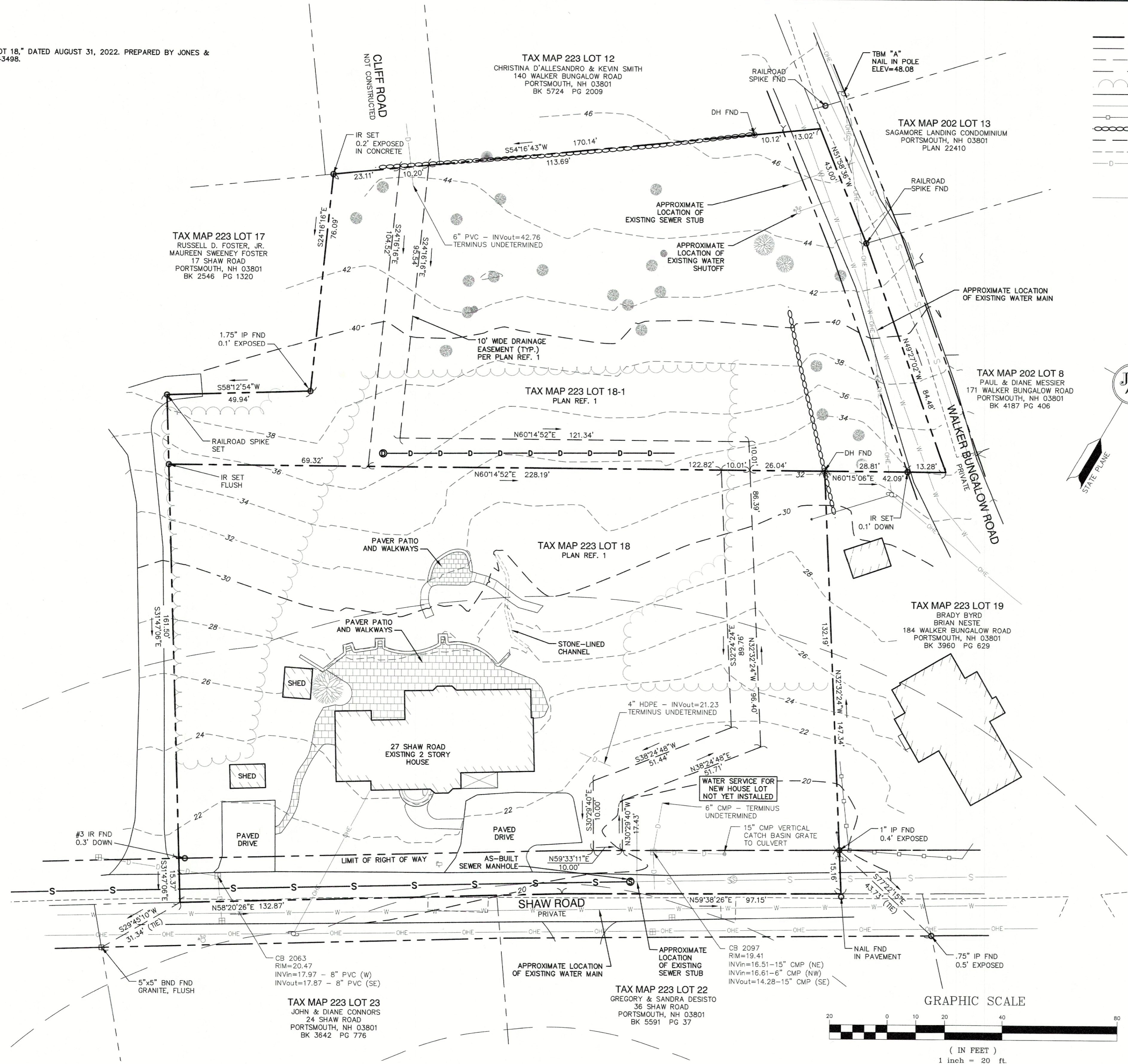

LEGEND

- PROPERTY LINE
- - - ABUTTER PROPERTY LINE
- BUILDING SETBACK
- SURVEY TIE LINES
- TREE LINE
- EDGE OF PAVEMENT
- OVERHEAD ELECTRIC LINES
- FENCE
- STONE WALL
- 100' MAJOR CONTOUR
- 102' MINOR CONTOUR
- DRAIN LINE
- CATCH BASIN
- DRAIN MANHOLE
- WATER LINE
- WATER SHUTOFF
- UTILITY POLE
- GUY WIRE ANCHOR
- ELECTRIC METER

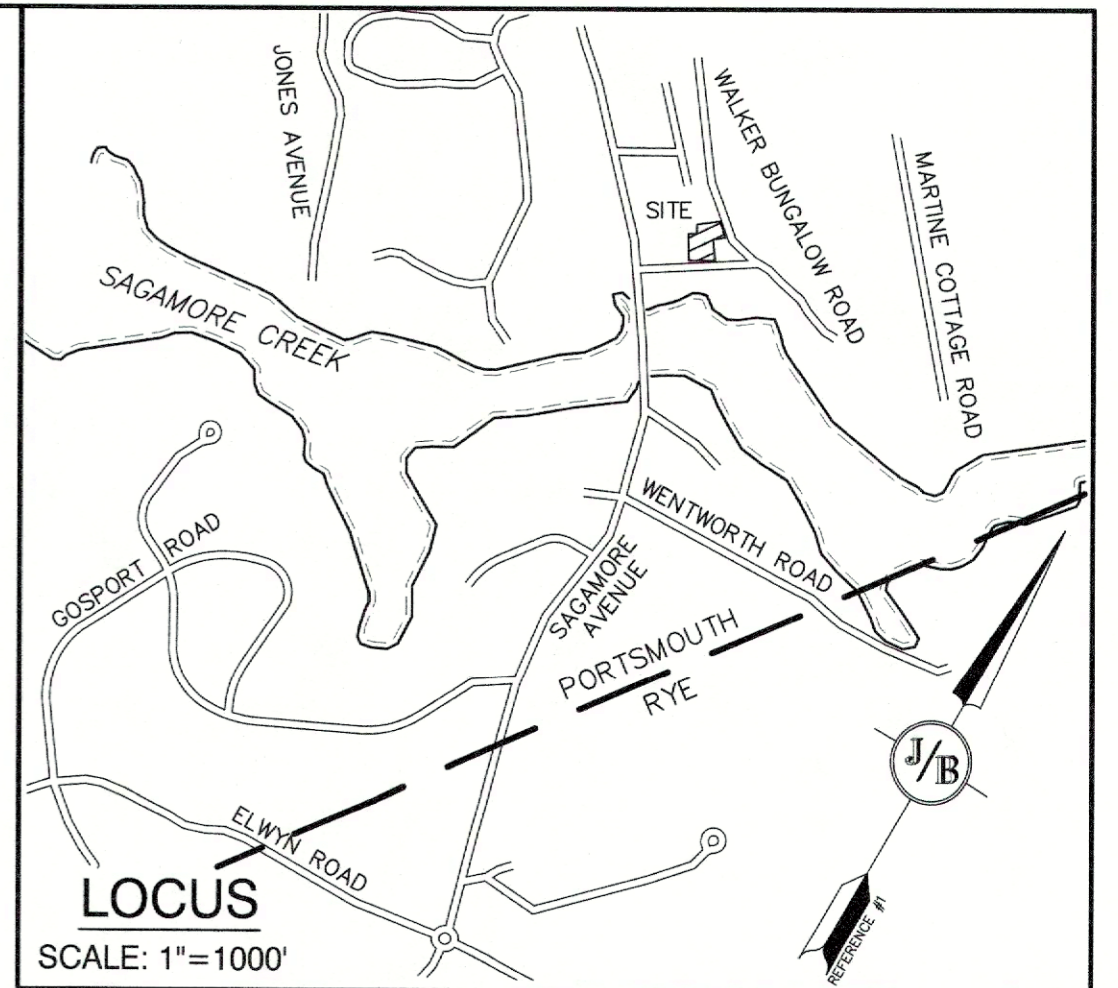

NOTES:

1. THE INTENT OF THIS PLAN IS TO SHOW THE EXISTING CONDITIONS OF LOT 18 DEPICTED ON PORTSMOUTH TAX MAP 223.
2. ZONING DISTRICT: SINGLE RESIDENCE B
LOT AREA MINIMUM = 15,000 SF
LOT FRONTAGE MINIMUM = 100'
BUILDING SETBACKS (MINIMUM):
FRONT SETBACK = 30'
SIDE SETBACK = 10'
REAR SETBACK = 30'
WETLAND SETBACK = 100'; LIMITED CUT 50'. (NO WETLANDS OBSERVED)
MAX. BUILDING HEIGHT = 35'
3. THE UTILITY LOCATIONS SHOWN HEREON WERE DETERMINED BY OBSERVED ABOVE GROUND EVIDENCE AND SHOULD BE CONSIDERED APPROXIMATE IN LOCATION ONLY. LOCATION, DEPTH, SIZE, TYPE, EXISTENCE OR NONEXISTENCE OF UNDERGROUND UTILITIES AND/OR UNDERGROUND STORAGE TANKS WAS NOT VERIFIED BY THIS SURVEY. ALL CONTRACTORS SHOULD NOTIFY IN WRITING ALL UTILITY COMPANIES AND GOVERNMENT AGENCIES PRIOR TO ANY EXCAVATION WORK OR CALL DIG-SAFE AT 1-888-DIG-SAFE.
4. THE SUBJECT PARCEL IS NOT LOCATED WITHIN AN AREA HAVING A ZONE DESIGNATION BY THE FEDERAL EMERGENCY MANAGEMENT AGENCY (FEMA), ON FLOOD INSURANCE RATE MAP NO. 33015C0286F, WITH EFFECTIVE DATE OF JANUARY 29, 2021.
5. BASIS OF BEARING: HORIZONTAL - NAD83 NH STATE PLANE.
VERTICAL - NAVD88.
6. CERTAIN DATA HEREON MAY VARY FROM RECORDED DATA DUE TO DIFFERENCES IN DECLINATION, ORIENTATION, AND METHODS OF MEASUREMENT.
7. ALL BOOK AND PAGE NUMBERS REFER TO THE ROCKINGHAM COUNTY REGISTRY OF DEEDS.
8. THE TAX MAP AND LOT NUMBERS ARE BASED ON THE CITY OF PORTSMOUTH TAX RECORDS AND ARE SUBJECT TO CHANGE.
9. RESEARCH WAS PERFORMED AT THE CITY OF PORTSMOUTH ASSESSOR'S OFFICE AND PLANNING OFFICE, AND THE ROCKINGHAM COUNTY REGISTRY OF DEEDS.
10. THIS SURVEY IS NOT A CERTIFICATION TO OWNERSHIP OR TITLE OF LANDS SHOWN. OWNERSHIP AND ENCUMBRANCES ARE MATTERS OF TITLE EXAMINATION NOT OF A BOUNDARY SURVEY. THE INTENT OF THIS PLAN IS TO RETRACE THE BOUNDARY LINES OF DEEDS REFERENCED HEREON. OWNERSHIP OF ADJOINING PROPERTIES IS ACCORDING TO ASSESSOR'S RECORDS. THIS PLAN MAY OR MAY NOT INDICATE ALL ENCUMBRANCES EXPRESSED, IMPLIED OR PRESCRIPTIVE.
11. ANY USE OF THIS PLAN AND OR ACCOMPANYING DESCRIPTIONS SHOULD BE DONE WITH LEGAL COUNSEL, TO BE CERTAIN THAT TITLES ARE CLEAR, THAT INFORMATION IS CURRENT, AND THAT ANY NECESSARY CERTIFICATES ARE IN PLACE FOR A PARTICULAR CONVEYANCE, OR OTHER USES.
12. NO WETLANDS WERE OBSERVED ON THE SUBJECT PREMISES.
13. SURVEY TIE LINES SHOWN HEREON ARE NOT BOUNDARY LINES. THEY SHOULD ONLY BE USED TO LOCATE THE PARCEL SURVEYED FROM THE FOUND MONUMENTS SHOWN AND LOCATED BY THIS SURVEY.
14. SHAW ROAD AND WALKER BUNGALOW ROAD ARE PRIVATE WAYS. RECORD DEEDS AND PLANS INDICATE A RIGHT OF WAY WIDTH OF THIRTY FEET FOR SHAW ROAD. NO WIDTH IS INDICATED FOR WALKER BUNGALOW ROAD. THE BOUNDARY LINE OF THE SUBJECT PARCEL HAS BEEN HELD AS THE CENTER OF SAID WAYS.

CERTIFICATION:

PURSUANT TO RSA 676:18-III AND RSA 672:14
I CERTIFY THAT THIS SURVEY PLAT IS NOT A SUBDIVISION PURSUANT TO THIS TITLE AND THAT THE LINES OF STREETS AND WAYS SHOWN ARE THOSE OF PUBLIC OR PRIVATE STREETS OR WAYS ALREADY ESTABLISHED AND THAT NO NEW WAYS ARE SHOWN.
I CERTIFY THAT THIS PLAT WAS PREPARED UNDER MY DIRECT SUPERVISION, THAT IT IS THE RESULT OF A FIELD SURVEY BY THIS OFFICE AND HAS AN UNADJUSTED LINEAR ERROR OF CLOSURE THAT EXCEEDS BOTH THE MINIMUM OF 1:10,000 AS DEFINED IN SECTION 503.04 OF THE NEW HAMPSHIRE CODE OF ADMINISTRATIVE RULES AND THE MINIMUM OF 1:15,000 AS DEFINED IN SECTION 4.2 OF THE N.H.L.S.A. ETHICS AND STANDARDS.
THIS SURVEY CONFORMS TO A CATEGORY 1 CONDITION 1 SURVEY AS DEFINED IN SECTION 4.1 OF THE N.H.L.S.A. ETHICS AND STANDARDS.

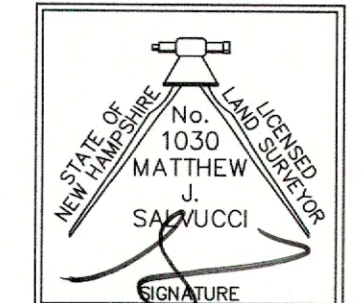

MATTHEW J. SALVUCCI, LLS 1030
ON BEHALF OF JONES & BEACH ENGINEERS, INC.

DATE: 7/5/23

TOTAL LOT AREA
57,354 SQ. FT.
1.32 ACRES

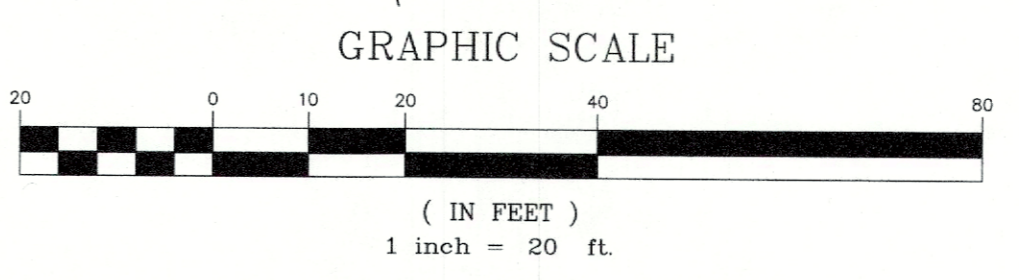

Design: JAC	Draft: MJS	Date: 11/18/21
Checked: JAC	Scale: 1"=20'	Project No.: 21222
Drawing Name: 21222-PLAN.dwg		
THIS PLAN SHALL NOT BE MODIFIED WITHOUT WRITTEN PERMISSION FROM JONES & BEACH ENGINEERS, INC. (JBE). ANY ALTERATIONS, AUTHORIZED OR OTHERWISE, SHALL BE AT THE USER'S SOLE RISK AND WITHOUT LIABILITY TO JBE.		

REV.	DATE	REVISION	BY
9	6/14/23	UPDATED EXISTING DRAINAGE	DJM
8	6/6/23	UPDATED EXISTING CONDITIONS PLAN	DJM
7	5/26/23	AMENDED SUBDIVISION PLAN	DJM
6	6/23/22	REMOVED HOLDING TANK	DJM
5	6/2/22	ADDED DRAINAGE EASEMENTS	MJS

J/B Jones & Beach Engineers, Inc.
Civil Engineering Services
85 Portsmouth Ave. PO Box 219 Stratham, NH 03885
603-772-4746
FAX: 603-772-0227
E-MAIL: JBE@JONESANDBEACH.COM



Plan Name:	EXISTING CONDITIONS PLAN
Project:	PROPOSED SUBDIVISION 27 SHAW ROAD, PORTSMOUTH, NH
Owner of Record:	CLYDE LOGUE & MARY DUFF KASTEL 27 SHAW RD., PORTSMOUTH, NH 03801 BK 6455 PG 1068

DRAWING No.	C1
SHEET 1 OF 2	JBE PROJECT NO. 21222







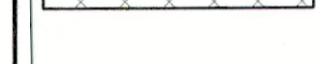







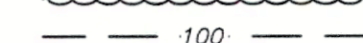
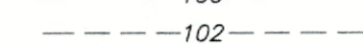

PLAN REFERENCES:

- "SUBDIVISION PLAN, TAX MAP 223 LOT 18," DATED AUGUST 31, 2022. PREPARED BY JONES & BEACH ENGINEERS, INC. R.C.R.D. D-43498.

EASEMENT CHANGES

-  EXISTING EASEMENT ON LOT 18-1 TO REMAIN
-  EXISTING EASEMENT ON LOT 18-1 TO BE REDEEDED TO LOT 18-0-1
-  EXISTING EASEMENT TO BE RELOCATED ON LOT 18-0-1
-  PROPOSED RELOCATED EASEMENT ON LOT 18-0-1

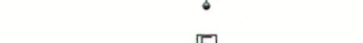
LEGEND

-  EXISTING PROPERTY LINE
-  PROPOSED PROPERTY LINE
-  ABUTTER PROPERTY LINE
-  BUILDING SETBACK
-  SURVEY TIE LINES
-  TREE LINE
-  EDGE OF PAVEMENT
-  OVERHEAD ELECTRIC LINES
-  STONE WALL
-  MAJOR CONTOUR
-  MINOR CONTOUR
-  DRAIN LINE
-  CATCH BASIN
-  DRAIN MANHOLE
-  WATER LINE
-  WATER SHUTOFF
-  UTILITY POLE
-  GUY WIRE ANCHOR
-  ELECTRIC METER

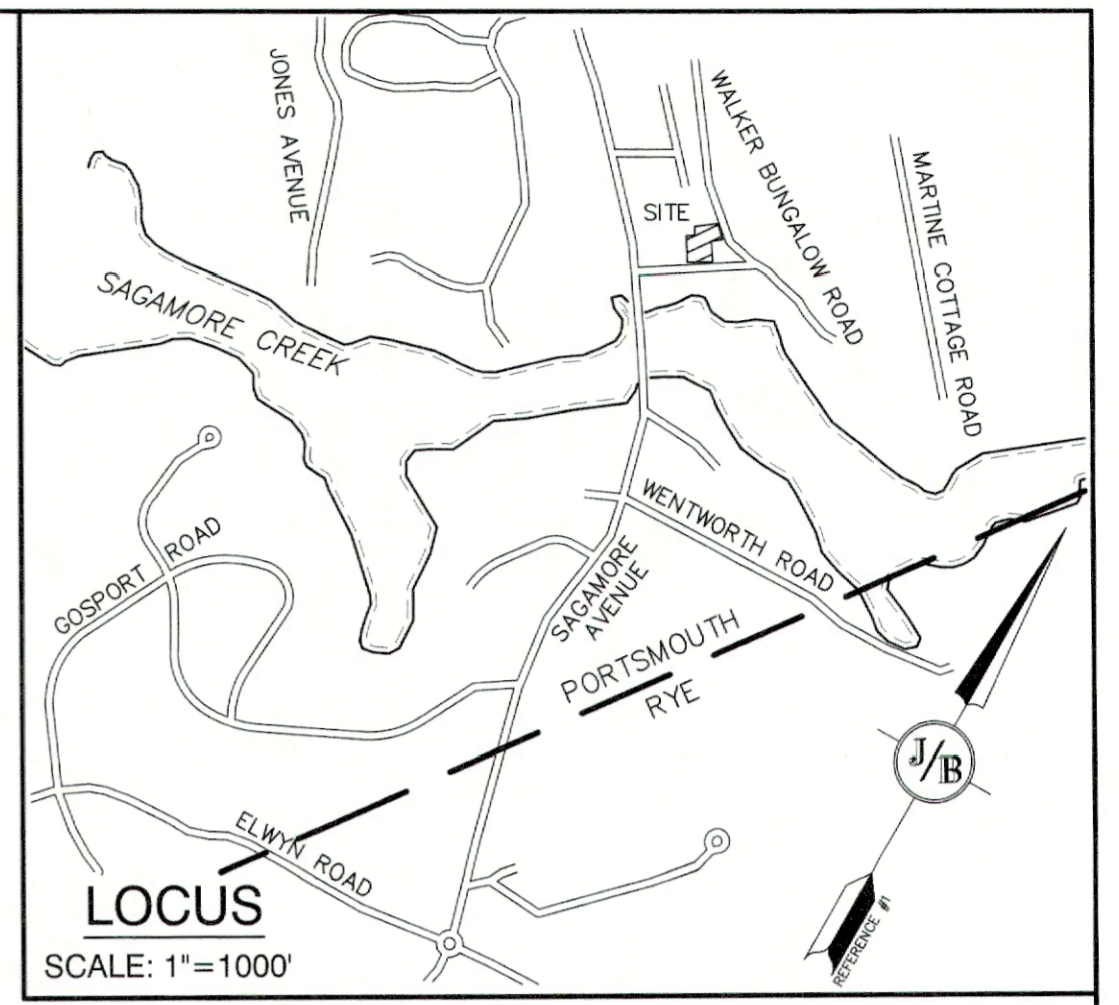

NOTES:

- THE INTENT OF THIS PLAN IS TO ADJUST THE LOT LINE BETWEEN LOTS 18 AND 18-1 AS DEPICTED ON PORTSMOUTH TAX MAP 223, AND THEN SUBDIVIDE LOT 18. EACH WILL BE SERVICED BY CITY WATER AND SEWER.
- ZONING DISTRICT: SINGLE RESIDENCE B
LOT AREA MINIMUM = 15,000 SF
LOT FRONTAGE MINIMUM = 100'
BUILDING SETBACKS (MINIMUM):
FRONT SETBACK = 30'
SIDE SETBACK = 30'
REAR SETBACK = 30'
WETLAND SETBACK = 100', LIMITED CUT 50'. (NO WETLANDS OBSERVED)
MAX. BUILDING HEIGHT = 35'
- THE UTILITY LOCATIONS SHOWN HEREON WERE DETERMINED BY OBSERVED ABOVE GROUND EVIDENCE AND SHOULD BE CONSIDERED APPROXIMATE IN LOCATION ONLY. LOCATION, DEPTH, SIZE, TYPE, EXISTENCE OR NONEXISTENCE OF UNDERGROUND UTILITIES AND/OR UNDERGROUND STORAGE TANKS WAS NOT VERIFIED BY THIS SURVEY. ALL CONTRACTORS SHOULD NOTIFY IN WRITING ALL UTILITY COMPANIES AND GOVERNMENT AGENCIES PRIOR TO ANY EXCAVATION WORK OR CALL DIG-SAFE AT 1-888-DIG-SAFE.
- THE SUBJECT PARCEL IS NOT LOCATED WITHIN AN AREA HAVING A ZONE DESIGNATION BY THE FEDERAL EMERGENCY MANAGEMENT AGENCY (FEMA), ON FLOOD INSURANCE RATE MAP NO. 33015C0286F, WITH EFFECTIVE DATE OF JANUARY 29, 2021.
- BASIS OF BEARING: HORIZONTAL - NAD83 NH STATE PLANE.
VERTICAL - NAVD88.
- CERTAIN DATA HEREON MAY VARY FROM RECORDED DATA DUE TO DIFFERENCES IN DECLINATION, ORIENTATION, AND METHODS OF MEASUREMENT.
- ALL BOOK AND PAGE NUMBERS REFER TO THE ROCKINGHAM COUNTY REGISTRY OF DEEDS.
- THE TAX MAP AND LOT NUMBERS ARE BASED ON THE CITY OF PORTSMOUTH TAX RECORDS AND ARE SUBJECT TO CHANGE.
- RESEARCH WAS PERFORMED AT THE CITY OF PORTSMOUTH ASSESSOR'S OFFICE AND PLANNING OFFICE, AND THE ROCKINGHAM COUNTY REGISTRY OF DEEDS.
- THIS SURVEY IS NOT A CERTIFICATION TO OWNERSHIP OR TITLE OF LANDS SHOWN. OWNERSHIP AND ENCUMBRANCES ARE MATTERS OF TITLE EXAMINATION NOT OF A BOUNDARY SURVEY. THE INTENT OF THIS PLAN IS TO REINSTATE THE BOUNDARY LINES OF DEEDS REFERENCED HEREON. OWNERSHIP OF ADJOINING PROPERTIES IS ACCORDING TO ASSESSOR'S RECORDS. THIS PLAN MAY OR MAY NOT INDICATE ALL ENCUMBRANCES EXPRESSED, IMPLIED OR PRESCRIPTIVE.
- ANY USE OF THIS PLAN AND OR ACCOMPANYING DESCRIPTIONS SHOULD BE DONE WITH LEGAL COUNSEL, TO BE CERTAIN THAT TITLES ARE CLEAR, THAT INFORMATION IS CURRENT, AND THAT ANY NECESSARY CERTIFICATES ARE IN PLACE FOR A PARTICULAR CONVEYANCE, OR OTHER USES.
- NO WETLANDS WERE OBSERVED ON THE SUBJECT PREMISES.
- SURVEY TIE LINES SHOWN HEREON ARE NOT BOUNDARY LINES. THEY SHOULD ONLY BE USED TO LOCATE THE PARCEL SURVEYED FROM THE FOUND MONUMENTS SHOWN AND LOCATED BY THIS SURVEY.
- SHAW ROAD AND WALKER BUNGALOW ROAD ARE PRIVATE WAYS. RECORD DEEDS AND PLANS INDICATE A RIGHT OF WAY WIDTH OF THIRTY FEET FOR SHAW ROAD. NO WIDTH IS INDICATED FOR WALKER BUNGALOW ROAD. THE BOUNDARY LINE OF THE SUBJECT PARCEL HAS BEEN HELD AS THE CENTER OF SAID WAYS.
- PORTION OF EXISTING DRAINAGE EASEMENT ON LOT 18-1 IS TO REMAIN OR BE REDEEDED TO LOT 18-0-1 AS APPROPRIATE PER LOCATION OF PROPOSED PROPERTY LINE. PORTION OF EXISTING DRAINAGE EASEMENT ON LOT 18 AS INDICATED ON PLAN REFERENCE #1 IS TO BE RELEASED AND NEW DEED FOR EASEMENT ON LOT 18-0-1 IS TO BE RECORDED.

CERTIFICATION:

PURSUANT TO RSA 676:18-III AND RSA 672:14
I CERTIFY THAT THIS PLAN WAS PREPARED UNDER MY DIRECT SUPERVISION, THAT IT IS THE RESULT OF A FIELD SURVEY BY THIS OFFICE AND HAS AN UNADJUSTED LINEAR ERROR OF CLOSURE THAT EXCEEDS BOTH THE MINIMUM OF 1:10,000 AS DEFINED IN SECTION 503.04 OF THE NEW HAMPSHIRE CODE OF ADMINISTRATIVE RULES AND THE MINIMUM OF 1:15,000 AS DEFINED IN SECTION 4.2 OF THE N.H.L.S.A. ETHICS AND STANDARDS.
THIS SURVEY CONFORMS TO A CATEGORY 1 CONDITION 1 SURVEY AS DEFINED IN SECTION 4.1 OF THE N.H.L.S.A. ETHICS AND STANDARDS.

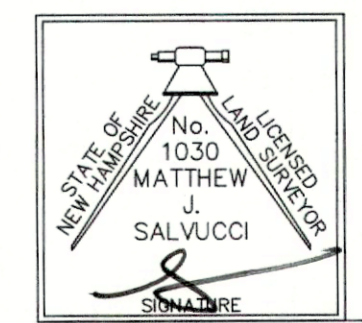

MATTHEW J. SALVUCCI, LLS 1030
ON BEHALF OF JONES & BEACH ENGINEERS, INC. DATE: 7/5/23

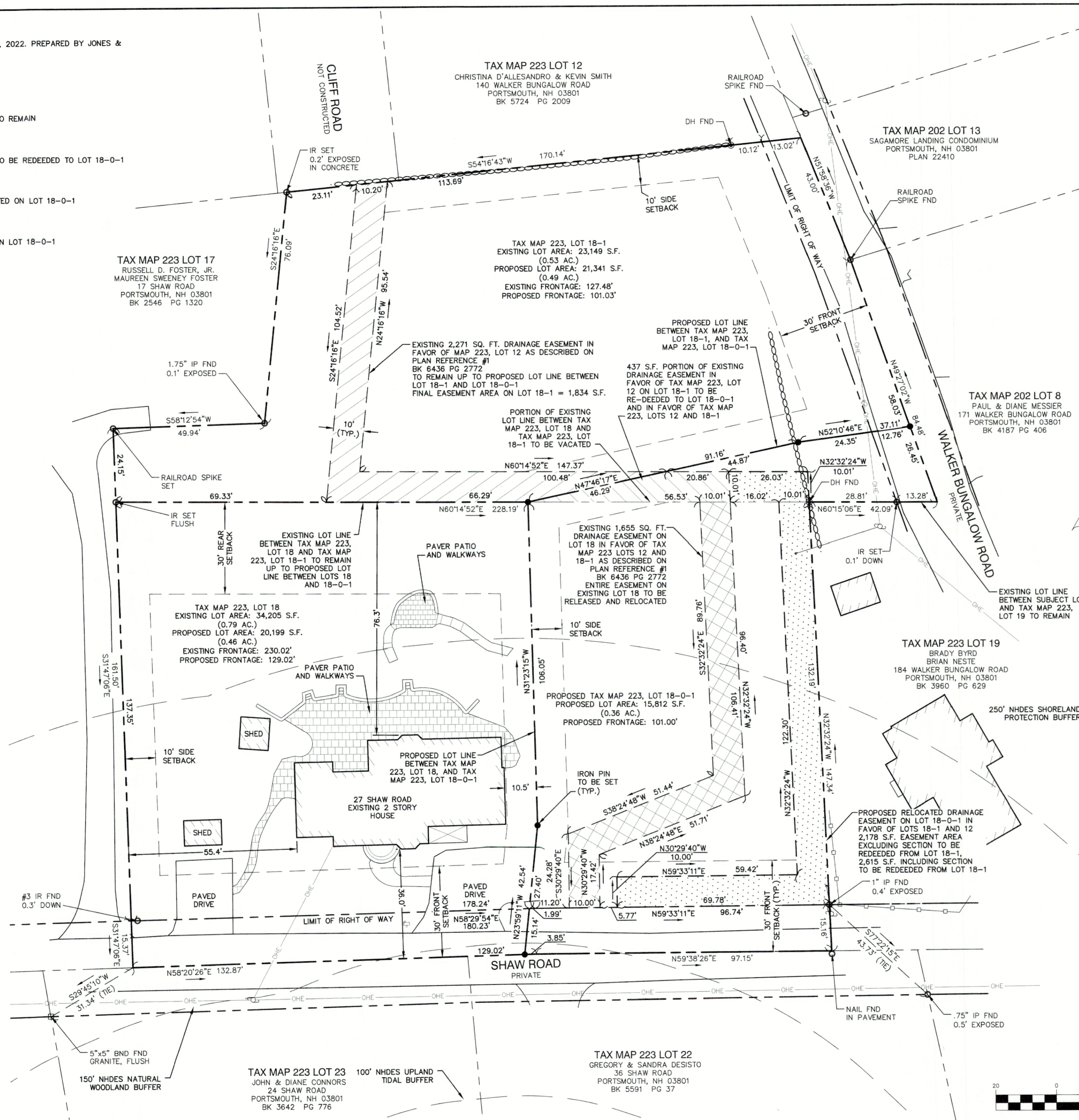
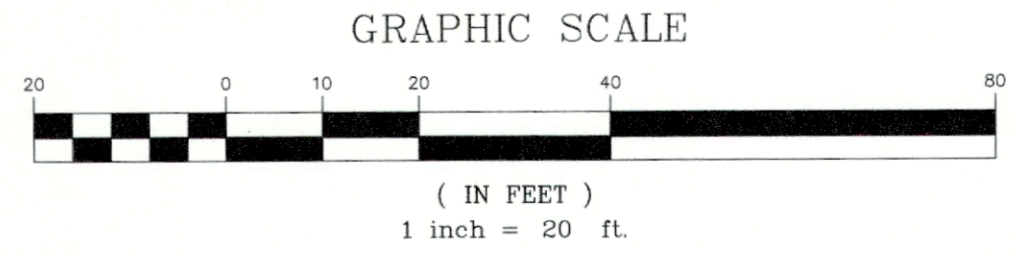

TOTAL LOT AREA
57,354 SQ. FT.
1.32 ACRES

APPROVED - PORTSMOUTH, NH
PLANNING BOARD

DATE:

REV.	DATE	REVISION	BY
9	6/14/23	UPDATED EXISTING DRAINAGE	DJM
8	6/6/23	UPDATED EXISTING CONDITIONS PLAN	DJM
7	5/26/23	AMENDED SUBDIVISION PLAN	DJM
6	6/23/22	REMOVED HOLDING TANK	DJM
5	6/2/22	ADDED DRAINAGE EASEMENTS	MJS

Designed and Produced in NH
J/B Jones & Beach Engineers, Inc.
Civil Engineering Services
85 Portsmouth Ave. PO Box 219 Stratham, NH 03885
603-772-4746
FAX: 603-772-0227
E-MAIL: JBE@JONESANDBEACH.COM

Plan Name: **AMENDED SUBDIVISION AND LOT LINE ADJUSTMENT PLAN**
TAX MAP 223, LOTS 18 & 18-1
Project: **PROPOSED SUBDIVISION**
27 SHAW ROAD, PORTSMOUTH, NH
Owner of Record: **CLYDE LOGUE & MARY DUFF KASTEL**
27 SHAW RD., PORTSMOUTH, NH 03801 BK 6455 PG 1068

DRAWING No.
A1
SHEET 2 OF 2
JBE PROJECT NO. 21222

Design: JAC Draft: MJS Date: 11/18/21
Checked: JAC Scale: 1"=20' Project No.: 21222
Drawing Name: 21222-PLAN.dwg
THIS PLAN SHALL NOT BE MODIFIED WITHOUT WRITTEN PERMISSION FROM JONES & BEACH ENGINEERS, INC. (JBE). ANY ALTERATIONS, AUTHORIZED OR OTHERWISE, SHALL BE AT THE USER'S SOLE RISK AND WITHOUT LIABILITY TO JBE.

GRADING AND DRAINAGE NOTES

- DO NOT BEGIN CONSTRUCTION UNTIL ALL STATE AND LOCAL PERMITS HAVE BEEN APPLIED FOR AND RECEIVED.
- CONTRACTOR SHALL OBTAIN A "DIGSAFE" NUMBER AT LEAST 72 HOURS PRIOR TO COMMENCING CONSTRUCTION.
- ALL CONSTRUCTION SHALL MEET THE MINIMUM CONSTRUCTION STANDARDS OF THE CITY OF PORTSMOUTH AND NHDOT STANDARD SPECIFICATIONS FOR ROAD AND BRIDGE CONSTRUCTION, LATEST EDITION. THE MORE STRINGENT SPECIFICATION SHALL GOVERN.
- ALL BENCHMARKS AND TOPOGRAPHY SHALL BE FIELD VERIFIED BY THE CONTRACTOR PRIOR TO INITIATING CONSTRUCTION.
- UNLESS OTHERWISE AGREED IN WRITING, THE CONTRACTOR SHALL BE RESPONSIBLE FOR ESTABLISHING AND MAINTAINING TEMPORARY BENCHMARKS (TBM) AND PERFORMING ALL CONSTRUCTION SURVEY LAYOUT.
- PROTECTION OF SUBGRADE: THE CONTRACTOR SHALL BE REQUIRED TO MAINTAIN STABLE, DEWATERED SUBGRADES FOR FOUNDATIONS, PAVEMENT AREAS, UTILITY TRENCHES, AND OTHER AREAS DURING CONSTRUCTION. SUBGRADE DISTURBANCE MAY BE INFLUENCED BY EXCAVATION METHODS, MOISTURE, PRECIPITATION, GROUNDWATER CONTROL, AND CONSTRUCTION ACTIVITIES. THE CONTRACTOR SHALL TAKE PRECAUTIONS TO PREVENT SUBGRADE DISTURBANCE. SUCH PRECAUTIONS MAY INCLUDE DIVERTING STORMWATER RUNOFF AWAY FROM CONSTRUCTION AREAS, REDUCING TRAFFIC IN SENSITIVE AREAS, AND MAINTAINING AN EFFECTIVE DEWATERING PROGRAM. SOILS EXHIBITING HEAVING OR INSTABILITY SHALL BE OVER EXCAVATED TO MORE COMPETENT BEARING SOIL AND REPLACED WITH FREE DRAINING STRUCTURAL FILL. IF THE EARTHWORK IS PERFORMED DURING FREEZING WEATHER, EXPOSED SUBGRADES ARE SUSCEPTIBLE TO FROST. NO FILL OR UTILITIES SHALL BE PLACED ON FROZEN GROUND. THIS WILL LIKELY REQUIRE REMOVAL OF A FROZEN SOIL CRUST AT THE COMMENCEMENT OF EACH DAY'S OPERATIONS. THE FINAL SUBGRADE ELEVATION WOULD ALSO REQUIRE AN APPROPRIATE DEGREE OF INSULATION AGAINST FREEZING.
- IF SUITABLE, EXCAVATED MATERIALS SHALL BE PLACED AS FILL WITHIN UPLAND AREAS ONLY AND SHALL NOT BE PLACED WITHIN WETLANDS. PLACEMENT OF BORROW MATERIALS SHALL BE PERFORMED IN A MANNER THAT PREVENTS LONG TERM DIFFERENTIAL SETTLEMENT. EXCESSIVELY WET MATERIALS SHALL BE STOCKPILED AND ALLOWED TO DRAIN BEFORE PLACEMENT. FROZEN MATERIAL SHALL NOT BE USED FOR CONSTRUCTION.
- IN ORDER TO PROVIDE VISUAL CLARITY ON THE PLANS, DRAINAGE AND OTHER UTILITY STRUCTURES MAY NOT BE DRAWN TO SCALE. THE CONTRACTOR SHALL BE RESPONSIBLE FOR THE PROPER SIZING AND LOCATION OF ALL STRUCTURES AND IS DIRECTED TO RESOLVE ANY POTENTIAL DISCREPANCY WITH THE ENGINEER PRIOR TO CONSTRUCTION.
- GRASS UNDERDRAIN SOIL FILTER (GUSF) IS SIZED BASED ON AN ESTIMATED 6,000 S.F. IMPERVIOUS AREA FOR LOT 18-1.
- DRIP EDGES WILL BE UTILIZED AROUND PROPOSED HOUSES AS PART OF STORMWATER MANAGEMENT.

UTILITY NOTES

- ALL EXISTING UTILITIES SHOWN ARE PER PLAN REFERENCE #1. LOCATIONS AND COMPLETENESS ARE NOT GUARANTEED BY ENGINEER OR OWNER. IT IS THE CONTRACTOR'S RESPONSIBILITY TO VERIFY ALL EXISTING UTILITIES PRIOR TO BEGINNING ANY CONSTRUCTION ACTIVITIES.
- SITE WILL BE SERVED BY MUNICIPAL WATER & SEWER.
- COORDINATE ALL WATER LINE CONSTRUCTION ACTIVITIES WITH PORTSMOUTH PUBLIC WORKS.
- COORDINATE ALL SEWER LINE CONSTRUCTION ACTIVITIES WITH PORTSMOUTH PUBLIC WORKS AND CITY OF PORTSMOUTH SEWER EXTENSION PROJECT.

PLAN REFERENCE

- SHEET C1, "EXISTING CONDITIONS PLAN", DATED JULY 5, 2023, PREPARED JONES & BEACH ENGINEERS, INC.
- SHEET A1, "AMENDED SUBDIVISION AND LOT LINE ADJUSTMENT, TAX MAP 223, LOTS 18 & 18-1", DATED JULY 5, 2023, PREPARED JONES & BEACH ENGINEERS, INC.

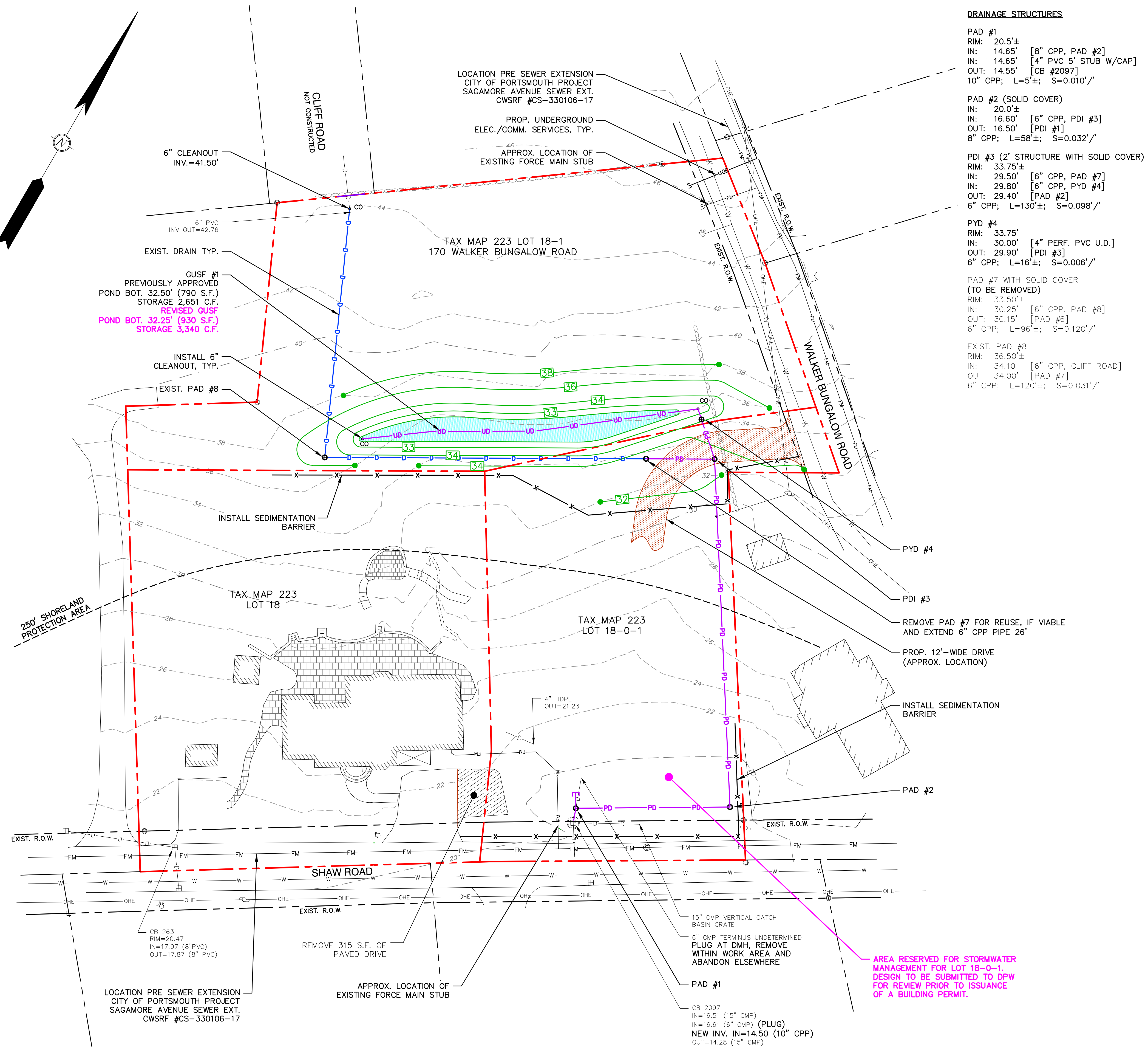
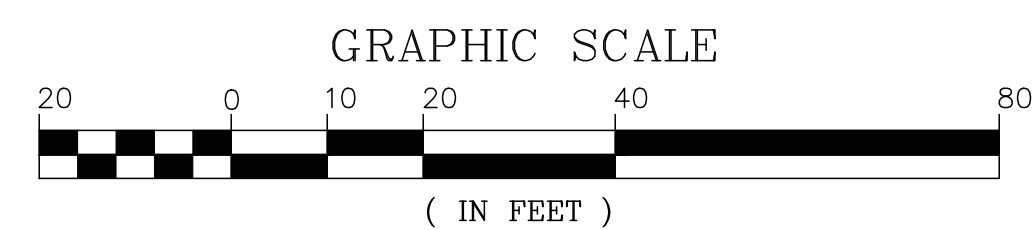

DRAINAGE STRUCTURES

- PAD #1**
 RIM: 20.5'±
 IN: 14.65' [8" CPP, PAD #2]
 IN: 14.65' [4" PVC 5' STUB W/CAP]
 OUT: 14.55' [CB #2097]
 10" CPP; L=5'±; S=0.010'/'
- PAD #2 (SOLID COVER)**
 RIM: 20.0'±
 IN: 16.60' [6" CPP, PDI #3]
 OUT: 16.50' [PDI #1]
 8" CPP; L=58'±; S=0.032'/'
- PDI #3 (2' STRUCTURE WITH SOLID COVER)**
 RIM: 33.75'±
 IN: 29.50' [6" CPP, PAD #7]
 IN: 29.80' [6" CPP, PAD #4]
 OUT: 29.40' [PAD #2]
 6" CPP; L=130'±; S=0.098'/'
- PDI #4**
 RIM: 33.75'
 IN: 20.0'±
 OUT: 29.90' [PDI #3]
 6" CPP; L=16'±; S=0.006'/'
- PAD #7 WITH SOLID COVER (TO BE REMOVED)**
 RIM: 33.50'±
 IN: 30.25' [6" CPP, PAD #8]
 OUT: 30.15' [PAD #6]
 6" CPP; L=96'±; S=0.120'/'
- EXIST. PAD #8**
 RIM: 36.50'±
 IN: 34.10 [6" CPP, CLIFF ROAD]
 OUT: 34.00' [PAD #7]
 6" CPP; L=120'±; S=0.031'/'

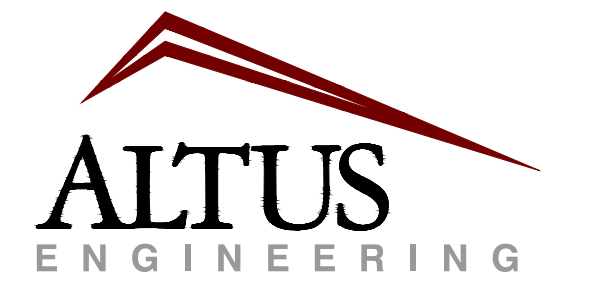

133 Court Street Portsmouth, NH 03801
 (603) 433-2335 www.altus-eng.com

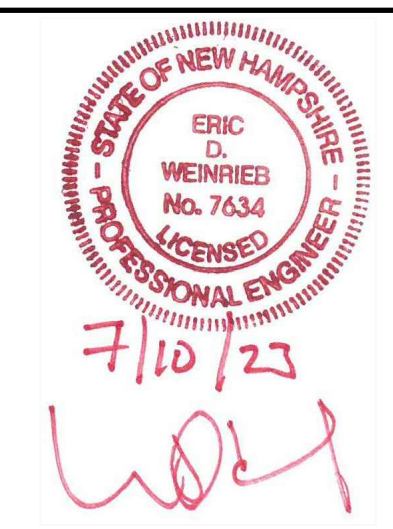

NOT FOR CONSTRUCTION
 ISSUED FOR: APPROVAL
 ISSUE DATE: JULY 10, 2023

NO.	DESCRIPTION	BY	DATE
0	INITIAL SUBMISSION	EDW	08/03/22
1	ADD GUSF, LLA	EDW	10/04/22
2	RE-ALIGN DRAINAGE	EDW	07/10/23

DRAWN BY: RMB
 APPROVED BY: EDW
 DRAWING FILE: 5279SITE-LOT2.DWG

SCALE:
 (22"x34") 1" = 20'
 (11"x17") 1" = 40'

OWNER/APPLICANT:
 BONNIE AND CLYDE LOGUE
 27 SHAW ROAD
 PORTSMOUTH, NH 03801

PROJECT:
 RESIDENTIAL DEVELOPMENT
 TAX MAP 223, LOTS 18 & 18-1
 27 SHAW ROAD
 PORTSMOUTH, NH

TITLE:
 STORMWATER MANAGEMENT PLAN

SHEET NUMBER:
 C - 1

P-5279

SEDIMENT AND EROSION CONTROL NOTES

PROJECT NAME AND LOCATION

AMENDED SUBDIVISION AND LOT LINE ADJUSTMENT PLAN
27 SHAW ROAD
PORTSMOUTH, NEW HAMPSHIRE
TAX MAP 223 LOTS 18 & 18-1

LONGITUDE: 70°44'56" W
LATITUDE: 43°03'23" N

OWNER / APPLICANT:

BONNIE AND CLYDE LOGUE
27 SHAW ROAD
PORTSMOUTH, NH 03801

DESCRIPTION

The project consists of creating a new single-family residential house lot with associated site and stormwater management improvements.

DISTURBED AREA

The total area to be disturbed for the development and stormwater improvements is approximately ±10,000 S.F. (±0.23 acres).

PROJECT PHASING

The proposed project will be completed in one phase.

NAME OF RECEIVING WATER

The majority of the site drains overland discharging to an unnamed wetland and a pond which discharges to Sagamore Creek.

SEQUENCE OF MAJOR ACTIVITIES

1. Install temporary erosion control measures including silt fences, stabilized construction entrance and inlet sediment filters as noted on the plan. All temporary erosion control measures shall be maintained in good working condition for the duration of the project.
2. Demolish existing building and utilities as shown on Site Plan and reclaim driveway materials if practical.
3. Strip loam and stockpile.
4. Construct building and associated improvements.
5. Rough grade site including placement of borrow materials.
6. Construct drainage structures, perimeter drains, utilities, swales & driveway base course materials.
7. Install landscaping.
8. Install driveway materials.
9. Loom (6" min) and seed all disturbed areas not paved or otherwise stabilized.
10. When all construction activity is complete and site is stabilized, remove all temporary erosion control measures and any sediment that has been trapped by these devices.

TEMPORARY EROSION & SEDIMENT CONTROL AND STABILIZATION PRACTICES

All work shall be in accordance with state and local permits. Work shall conform to the practices described in the "New Hampshire Stormwater Manual, Volumes 1 - 3", issued December 2008, as amended. As indicated in the sequence of Major Activities, the silt fences shall be installed prior to commencing any clearing or grading of the site. Structural controls shall be installed concurrently with the applicable activity. Once construction activity ceases permanently in an area, silt fences and any earth/dikes will be removed once permanent measures are established.

During construction, runoff will be diverted around the site with stabilized channels where possible. Sheet runoff from the site shall be filtered through hay bale barriers, stone check dams, and silt fences. All storm drain inlets shall be provided with hay bale filters or stone check dams. Stone rip rap shall be provided at the outlets of drain pipes and culverts where shown on the drawings.

Stabilize all ditches, swales, & level spreaders prior to directing flow to them.

Temporary and permanent vegetation and mulching is an integral component of the erosion and sedimentation control plan. All areas shall be inspected and maintained until vegetative cover is established. These control measures are essential to erosion prevention and also reduce costly rework of graded and shaped areas.

Temporary vegetation shall be maintained in these areas until permanent seeding is applied. Additionally, erosion and sediment control measures shall be maintained until permanent vegetation is established.

INSTALLATION, MAINTENANCE AND INSPECTION PROCEDURES FOR TEMPORARY EROSION AND SEDIMENT CONTROL MEASURES

A. GENERAL

These are general inspection and maintenance practices that shall be used to implement the plan:

1. The smallest practical portion of the site shall be denuded at one time.
2. All control measures shall be inspected at least once each week and following any storm event of 0.5 inches or greater.
3. All measures shall be maintained in good working order; if a repair is necessary, it will be initiated within 24 hours.
4. Built-up sediment shall be removed from silt fence or other barriers when it has reached one-third the height of the fence or bale, or when "bulges" occur.
5. All diversion dikes shall be inspected and any breaches promptly repaired.
6. Temporary seeding and planting shall be inspected for bare spots, washouts, and unhealthy growth.
7. The owner's authorized engineer shall inspect the site on a periodic basis to review compliance with the Plans.
8. An area shall be considered stable if one of the following has occurred:
 - a. Base coarse gravels have been installed in areas to be paved;
 - b. A minimum of 85% vegetated growth as been established;
 - c. A minimum of 3 inches of non-erosive material such as stone or riprap has been installed; or
 - d. Erosion control blankets have been properly installed.
9. The length of time of exposure of area disturbed during construction shall not exceed 45 days.

B. MULCHING

Mulch shall be used on highly erodible soils, on a critically eroding areas, on areas where conservation of moisture will facilitate plant establishment, and where shown on the plans.

1. Timing - In order for mulch to be effective, it must be in place prior to major storm events. There are two (2) types of standards which shall be used to assure this:
 - a. Apply mulch prior to any storm event. This is applicable when working within 100 feet of wetlands. It will be necessary to closely monitor weather predictions, usually by contacting the National Weather Service in Concord, to have adequate warning of significant storms.
 - b. Required Mulching within a specified time period. The time period can range from 21 to 28 days of inactivity on a area, the length of time varying with site conditions. Professional judgment shall be used to evaluate the interaction of site conditions (soil erodibility, season of year, extent of disturbance, proximity to sensitive resources, etc.) and the potential impact of erosion on adjacent areas to choose an appropriate time restriction.

2. Guidelines for Winter Mulch Application -

Type	Rate per 1,000 s.f.	Use and Comments
Hay or Straw	70 to 90 lbs.	Must be dry and free from mold. May be used with plantings.
Wood Chips or Bark Mulch	460 to 920 lbs.	Used mostly with trees and shrub plantings.
Jute and Fibrous Matting (Erosion Blanket)	As per manufacturer Specifications	Used in slope areas, water courses and other Control areas.
Crushed Stone 1/4" to 1-1/2" dia.	Spread more than 1/2" thick	Effective in controlling wind and water erosion.
Erosion Control Mix	2" thick (min)	<ul style="list-style-type: none"> * The organic matter content is between 80 and 100% dry weight basis. * Particle size by weight is 100% passing a 6" screen and a minimum of 70 % maximum of 85% passing a 0.75" screen. * The organic portion needs to be fibrous and elongated. * Large portions of silts, clays or fine sands are not acceptable in the mix. * Soluble salts content is less than 4.0 mmhos/cm. * The pH should fall between 5.0 and 8.0.

3. Maintenance - All mulches must be inspected periodically, in particular after rainstorms, to check for fill erosion. If less than 90% of the soil surface is covered by mulch, additional mulch shall be immediately applied.

C. TEMPORARY GRASS COVER

1. Seedbed Preparation - Apply fertilizer at the rate of 600 pounds per acre of 10-10-10. Apply limestone (equivalent to 50 percent calcium plus magnesium oxide) at a rate of three (3) tons per acre.
2. Seeding -
 - a. Utilize annual rye grass at a rate of 40 lbs./acre.
 - b. Where the soil has been compacted by construction operations, loosen soil to a depth of two (2) inches before applying fertilizer, lime and seed.
 - c. Apply seed uniformly by hand, cyclone seeder, or hydroseeder (slurry including seed and fertilizer). Hydroseedings, which include mulch, may be left on soil surface. Seeding rates must be increased 10X when hydroseeding.
3. Maintenance - Temporary seedings shall be periodically inspected. At a minimum, 95% of the soil surface should be covered by vegetation. If any evidence of erosion or sedimentation is apparent, repairs shall be made and other temporary measures used in the interim (mulch, filter barriers, check dams, etc.).

D. FILTERS

1. Sequence of Installation - Sediment barriers shall be installed prior to any soil disturbance of the contributing upslope drainage area.
2. Maintenance -
 - a. Silt fence barriers shall be inspected immediately after each rainfall and at least daily during prolonged rainfall. They shall be repaired if there are any signs of erosion or sedimentation below them. Any required repairs shall be made immediately. If there are signs of undercutting at the center or the edges, or impounding of large volumes of water, the sediment barriers shall be replaced with a temporary stone check dam.
 - b. Should the fabric on a silt fence or filter barrier decompose or become ineffective prior to the end of the expected usable life and the barrier still is necessary, the fabric shall be replaced promptly.
- a. Sediment deposits must be removed when deposits reach approximately one-third (1/3) the height of the barrier.
- b. Any sediment deposits remaining in place after the silt fence or other barrier is no longer required shall be removed. The area shall be prepared and seeded.
- c. Additional stone may have to be added to the construction entrance, rock barrier and riprap lined swales, etc., periodically to maintain proper function of the erosion control structure.

E. PERMANENT SEEDING -

1. Bedding - stones larger than 1 1/2", trash, roots, and other debris that will interfere with seeding and future maintenance of the area should be removed. Where feasible, the soil should be tilled to a depth of 5" to prepare a seedbed and mix fertilizer into the soil.
2. Fertilizer - lime and fertilizer should be applied evenly over the area prior to or at the time of seeding and incorporated into the soil. Kinds and amounts of lime and fertilizer should be based on an evaluation of soil tests. When a soil test is not available, the following minimum amounts should be applied:

Agricultural Limestone @ 100 lbs. per 1,000 s.f.
10-20-20 fertilizer @ 12 lbs. per 1,000 s.f.

Type	Lbs. / Acre	Lbs. / 1,000 sf
Tall Fescue	24	0.55
Creeping Red Fescue	24	0.55
Total	48	1.10

Seed Mixture (For slope embankments):
Grass Seed: Provide fresh, clean, new-crop seed complying with tolerance for purity and germination established by Official Seed Analysts of North America. Provide seed mixture composed of grass species, proportions and minimum percentages of purity, germination, and maximum percentage of weed seed, as specified:

Type	Min. Purity (%)	Min. Germination (%)	Kg./Hectare (Lbs./Acre)
Creeping Red Fescue (c)	96	85	45 (40)
Perennial Rye Grass (a)	98	90	35 (30)
Redtop	95	80	5 (5)
Alsike Clover	97	90(e)	5 (5)
			Total 90 (80)

- a. Ryegrass shall be a certified fine-textured variety such as Pennfence, Fiesta, Yorktown, Diplomat, or equal.
- b. Fescue varieties shall include - Creeping Red and/or Hard Reliant, Scaldis, Koket, or Jamestown.

4. Sodding - sodding is done where it is desirable to rapidly establish cover on a disturbed area. Sodding an area may be substituted for permanent seeding procedures anywhere on site. Bed preparation, fertilizing, and placement of sod shall be performed according to the S.C.S. Handbook. Sodding is recommended for steep sloped areas, areas immediately adjacent to sensitive water courses, easily erodible soils (fine sand/silt), etc.

WINTER CONSTRUCTION NOTES

1. All proposed vegetated areas which do not exhibit a minimum of 85% vegetative growth by October 15th, or which are disturbed after October 15th, shall be stabilized by seeding and installing erosion control blankets on slopes greater than 3:1, and elsewhere seeding and placing 3 to 4 tons of mulch per acre, secured with anchored netting. The installation of erosion control blankets or mulch and netting shall not occur over accumulated snow or on frozen ground and shall be completed in advance of thaw or spring melt events;
2. All ditches or swales which do not exhibit a minimum of 85% vegetative growth by October 15th, or which are disturbed after October 15th, shall be stabilized temporarily with stone or erosion control blankets appropriate for the design flow conditions; and
3. After November 15th, incomplete road or parking surfaces where work has stopped for the winter season shall be protected with a minimum of 3 inches of crushed gravel per NHDOT Item 304.3.

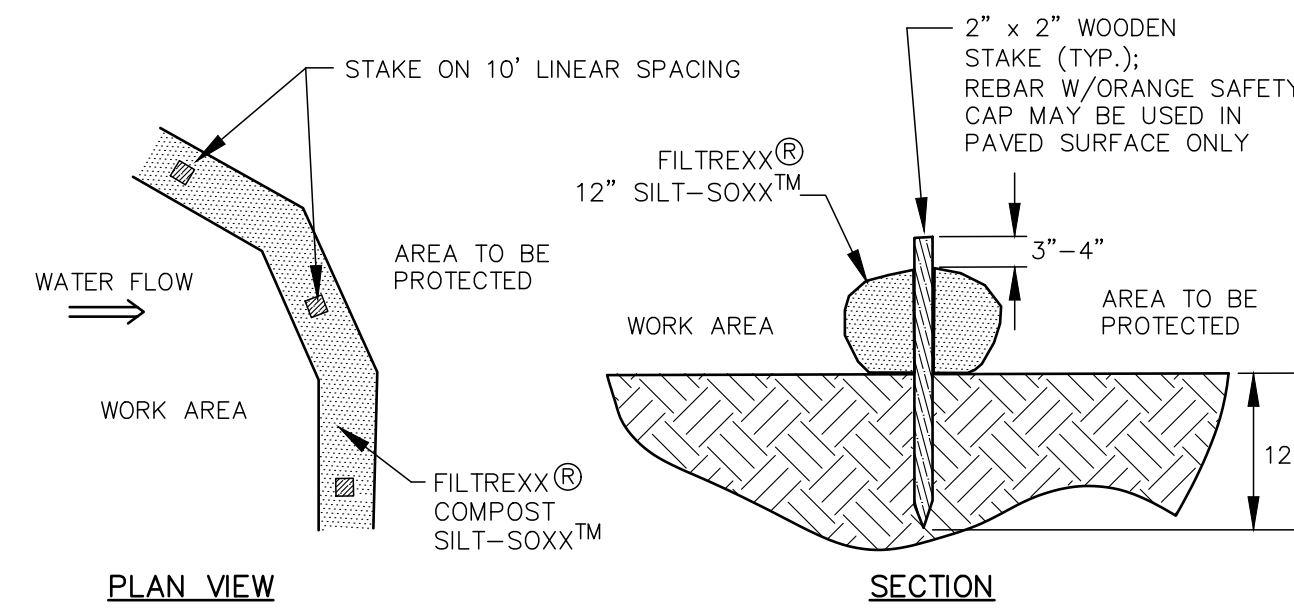

NOTES:

1. SILTSOXX MAY BE USED IN PLACE OF SILT FENCE OR OTHER SEDIMENT BARRIERS.
2. ALL MATERIAL TO MEET FILTREXX SPECIFICATIONS.
3. SILTSOXX COMPOST/SOIL/ROCK/SEED FILL MATERIAL SHALL BE ADJUSTED AS NECESSARY TO MEET THE REQUIREMENTS OF THE SPECIFIC APPLICATION.
4. ALL SEDIMENT TRAPPED BY SILTSOXX SHALL BE DISPOSED OF PROPERLY.

TUBULAR SEDIMENT BARRIER NOT TO SCALE

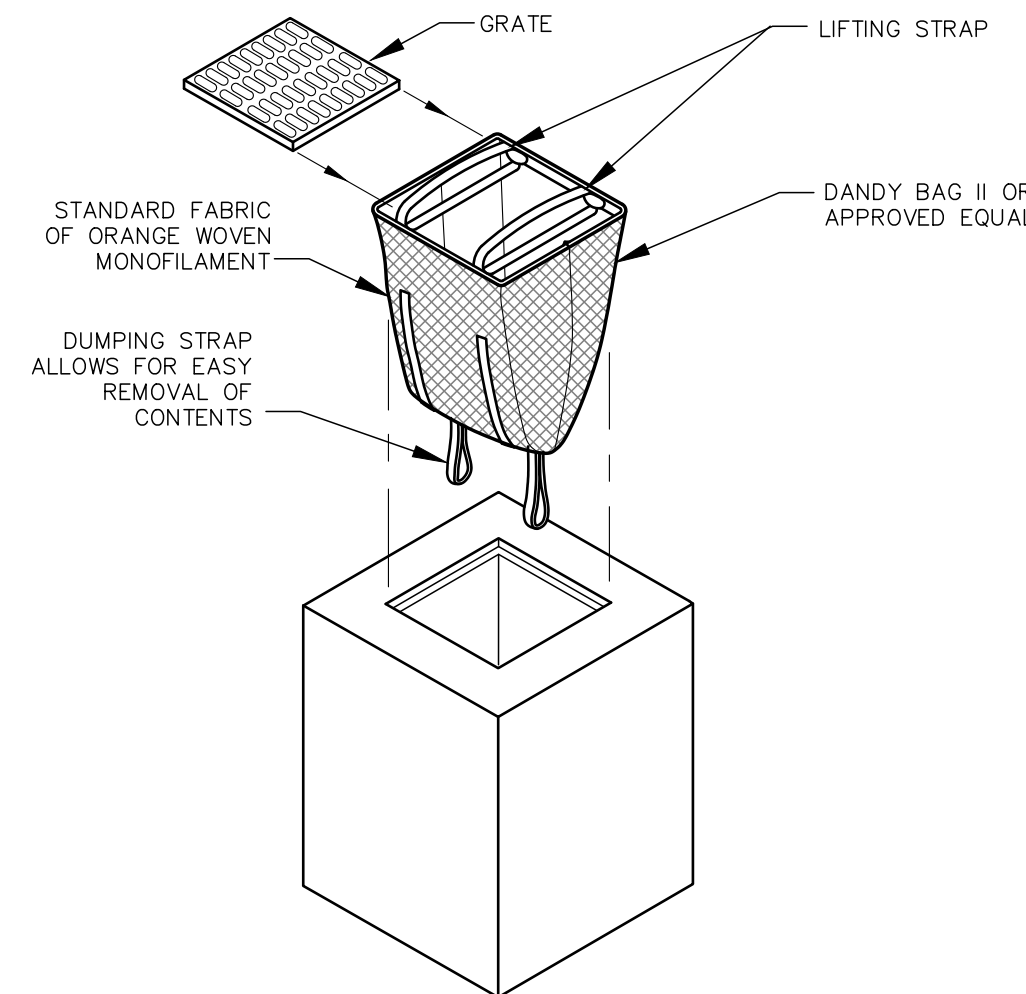

INSTALLATION AND MAINTENANCE:

INSTALLATION: REMOVE THE GRATE FROM CATCH BASIN. IF USING OPTIONAL OIL ABSORBENTS, PLACE ABSORBENT PILLOW IN UNIT. STAND GRATE ON END. MOVE THE TOP LIFTING STRAPS OUT OF THE WAY AND PLACE THE GRATE INTO CATCH BASIN INSERT SO THE GRATE IS BELOW THE TOP STRAPS AND ABOVE THE LOWER STRAPS. HOLDING THE LIFTING DEVICES, INSERT THE GRATE INTO THE INLET.

MAINTENANCE: REMOVE ALL ACCUMULATED SEDIMENT AND DEBRIS FROM VICINITY OF THE UNIT AFTER EACH STORM EVENT. AFTER EACH STORM EVENT AND AT REGULAR INTERVALS, LOOK INTO THE CATCH BASIN INSERT. IF THE CONTAINMENT AREA IS MORE THAN 1/3 FULL OF SEDIMENT, THE UNIT MUST BE EMPTIED. TO EMPTY THE UNIT, LIFT THE UNIT OUT OF THE INLET USING THE LIFTING STRAPS AND REMOVE THE GRATE. IF USING OPTIONAL ABSORBENTS, REPLACE ABSORBENT WHEN NEAR SATURATION.

UNACCEPTABLE INLET PROTECTION METHOD:

A SIMPLE SHEET OF GEOTEXTILE UNDER THE GRATE IS NOT ACCEPTABLE.

STORM DRAIN INLET PROTECTION NOT TO SCALE

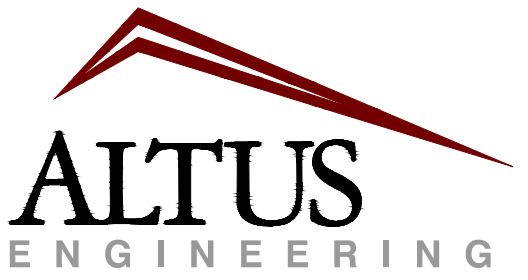

133 Court Street Portsmouth, NH 03801
(603) 433-2335 www.altus-eng.com

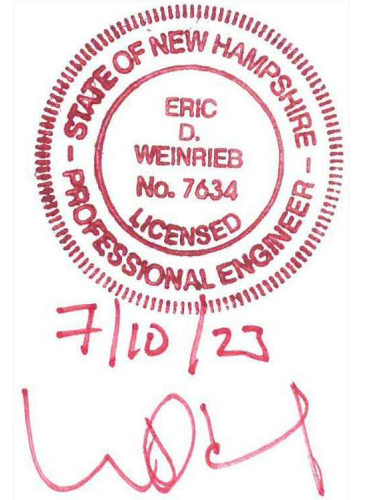

NOT FOR CONSTRUCTION

ISSUED FOR:

APPROVAL

ISSUE DATE:

JULY 10, 2023

REVISIONS

NO.	DESCRIPTION	BY	DATE
0	REVIEW	EDW	08/03/22
1	RE-ALIGN DRAINAGE	EDW	07/10/23

DRAWN BY: _____ RMB

APPROVED BY: _____ EDW

DRAWING FILE: _____ 5279SITE.DWG

SCALE:

NOT TO SCALE

OWNER/APPLICANT:

BONNIE AND CLYDE LOGUE
27 SHAW ROAD
PORTSMOUTH, NH 03801

PROJECT:

RESIDENTIAL DEVELOPMENT

TAX MAP 223, LOTS 18 & 18-1
27 SHAW ROAD
PORTSMOUTH, NH

TITLE:

DETAIL SHEET

SHEET NUMBER:

C - 2

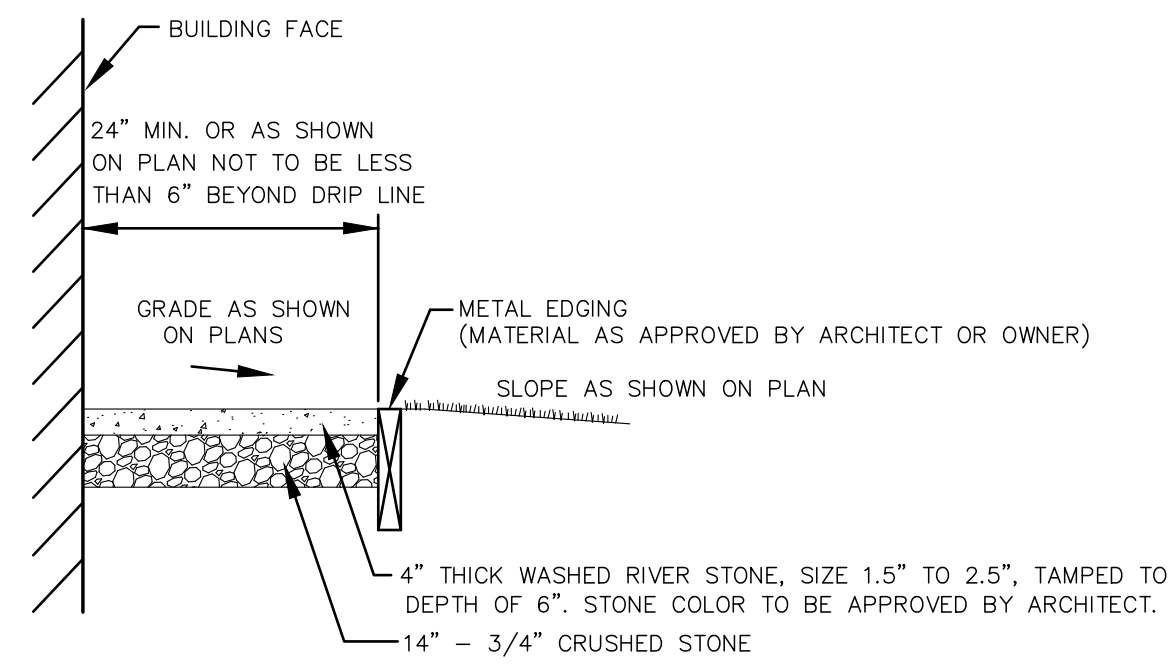

DRIP EDGE DETAIL

NOT TO SCALE

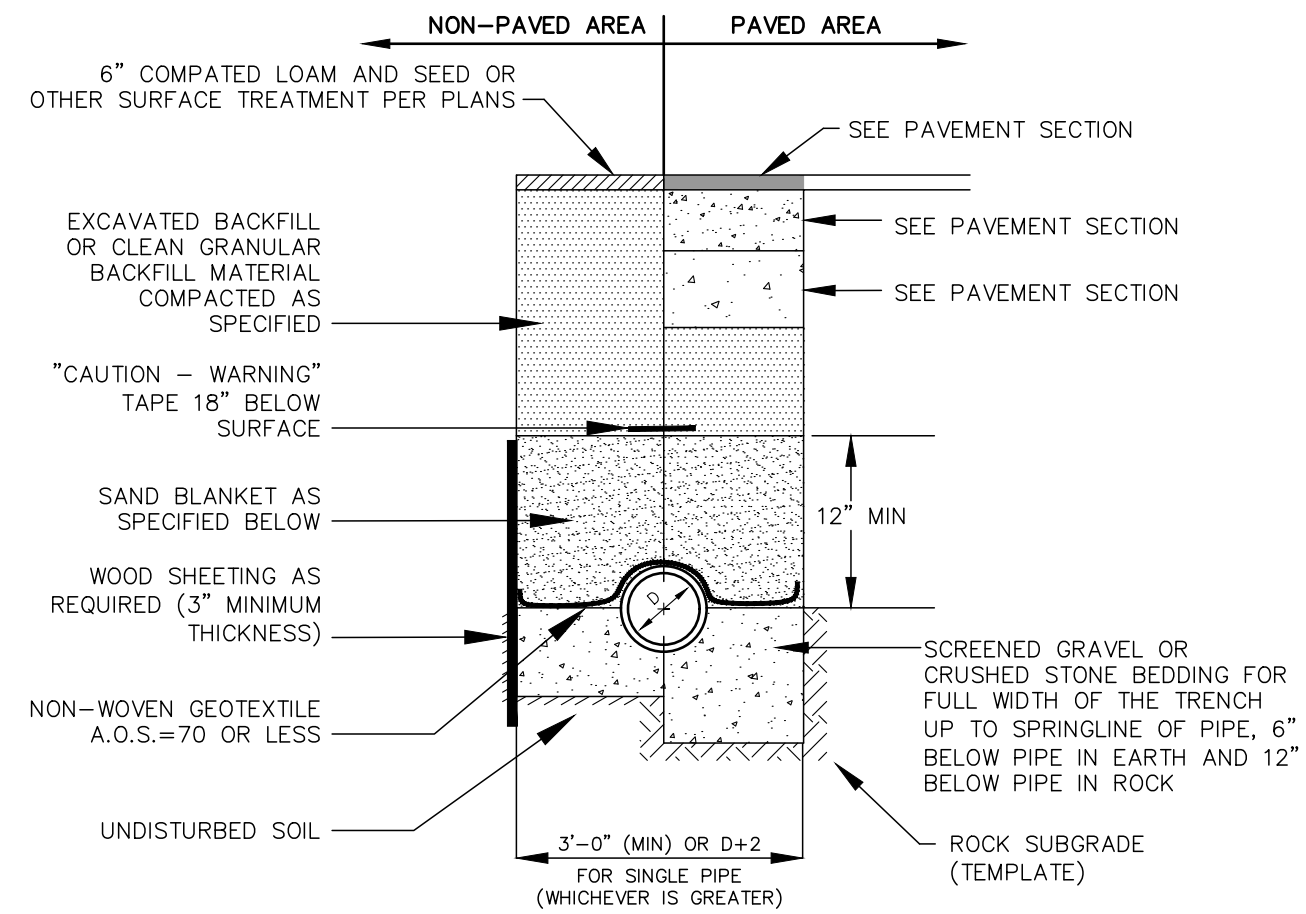

AREA DRAIN (PAD)

NOT TO SCALE

NOTES:

- FRAMES AND GRATES SHALL BE DUCTILE IRON PER ASTM A536 GRADE 70-50-05.
- DRAIN BASIN TO BE CUSTOM MANUFACTURED ACCORDING TO PLAN AND DETAILS.
- DRAINAGE CONNECTION STUB JOINT TIGHTNESS SHALL CONFORM TO ASTM D3212 FOR CORRUGATED HDPE, N-12HP AND PVC SEWER.
- INLINE DRAIN TO BE PVC, DIAMETER AS SPECIFIED AND AS MANUFACTURED BY ADS OR APPROVED EQUAL.
- THE CONTRACTOR SHALL INSTALL THE DRAIN BASIN PER THE MANUFACTURER'S RECOMMENDATIONS AND AS SHOWN ON THE DRAWINGS.
- FOR INSTALLATION IN PEDESTRIAN AND LANDSCAPE AREAS ONLY.

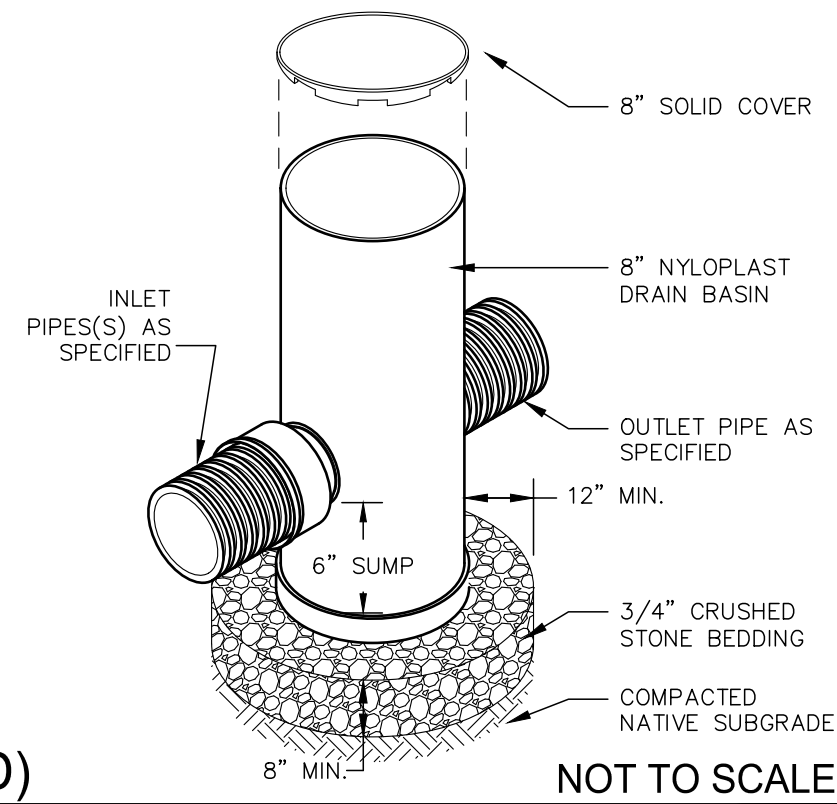

NOTES:

- BACKFILL MATERIAL BELOW PAVED OR CONCRETE AREAS, BEDDING MATERIAL, AND SAND BLANKET SHALL BE COMPACTED TO NOT LESS THAN 95% OF AASHTO T 99, METHOD C. SUITABLE BACKFILL MATERIAL BELOW LDAM AREAS SHALL BE COMPACTED TO NOT LESS THAN 90% OF AASHTO T 99, METHOD C.
- INSULATE GRAVITY SEWER AND FORCEMAINS WHERE THERE IS LESS THAN 5'-0" OF COVER WITH 2" THICK CLOSED CELL RIGID BOARD INSULATION, 18" ON EACH SIDE OF PIPE.
- MAINTAIN 12" MINIMUM HORIZONTAL SEPARATION AND WIDEN TRENCH ACCORDINGLY IF MULTIPLE PIPES ARE IN TRENCH.

SAND BLANKET/BARRIER	
SIEVE SIZE	% FINER BY WEIGHT
1/2"	90 - 100
200	0 - 15

SCREENED GRAVEL OR CRUSHED STONE BEDDING*	
SIEVE SIZE	% PASSING BY WEIGHT
1"	100
3/4"	90 - 100
3/8"	20 - 55
# 4	0 - 10
# 8	0 - 5

* EQUIVALENT TO STANDARD STONE SIZE #67 - SECTION 703 OF NHDOT STANDARD SPECIFICATIONS

DRAINAGE TRENCH

NOT TO SCALE

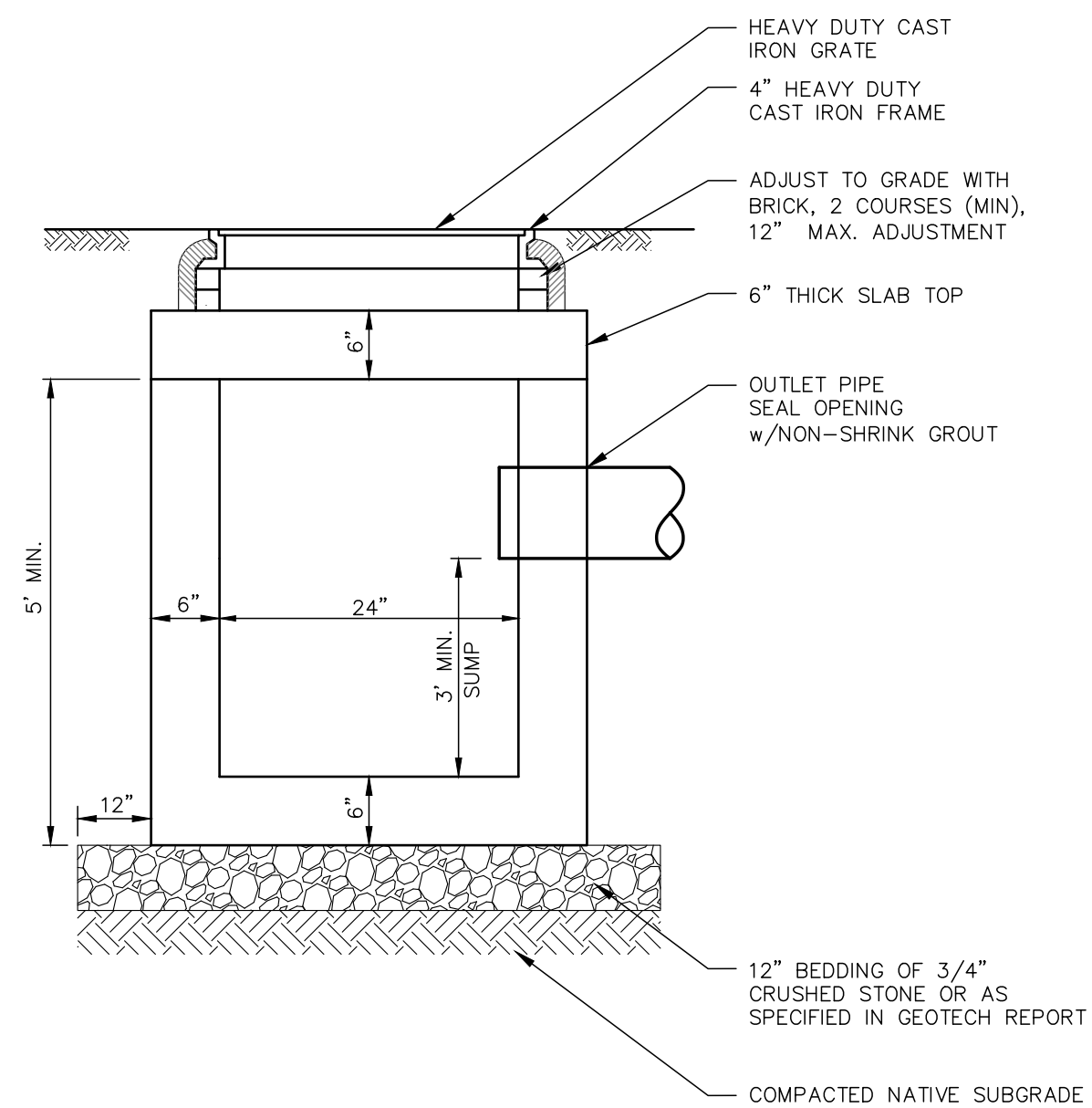

NOTES:

- STRUCTURE SHALL TO ACCOMMODATE HEAVY DUTY 24" SQ. C.I. FRAME AND GRATE.
- "24" SQUARE AREA DRAIN" AVAILABLE FROM PHOENIX PRECAST PRODUCTS (800-639-2199) OR APPROVED EQUAL.
- CONCRETE: 4,000 PSI AFTER 28 DAYS
- STRUCTURE SHALL BE STEEL REINFORCED MEET OR EXCEED H-20 LOADING.
- SEAL ALL TONGUE AND GROOVE JOINTS w/BUTYL RUBBER JOINT COMPOUND.

PDI #3 (2' STRUCTURE)

NOT TO SCALE

CLEANOUT DETAIL

NOT TO SCALE

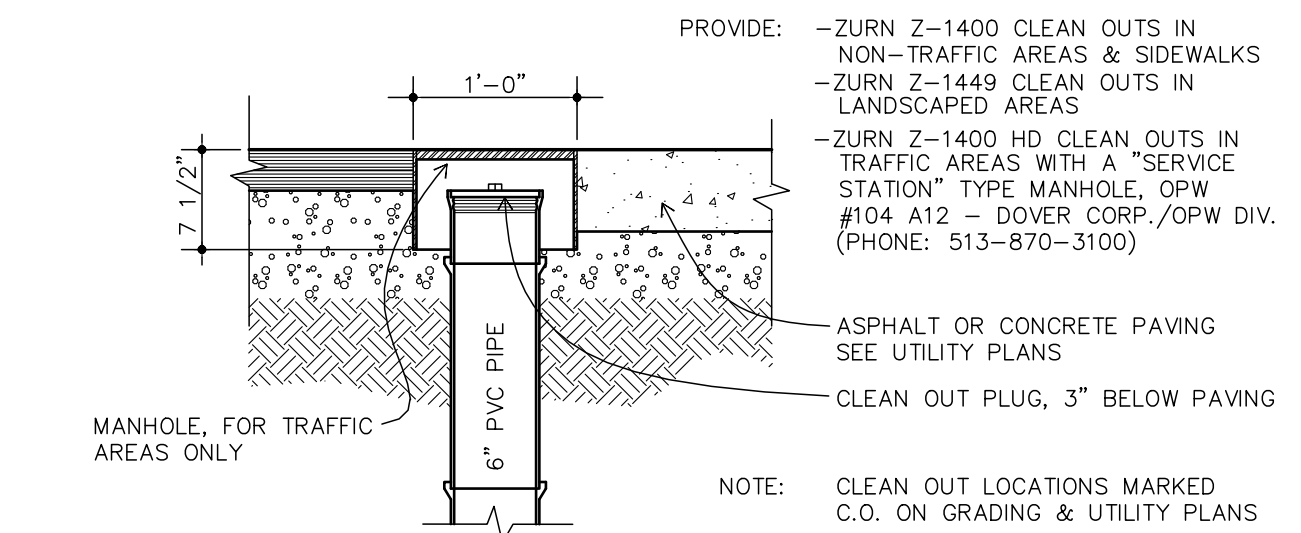

NOTES:

- WHEN CONTRACTOR EXCAVATES RAIN GARDEN AREA TO SUBGRADE, DESIGN ENGINEER SHALL PERFORM SUBSURFACE EVALUATION PRIOR TO THE PLACEMENT OF ANY SELECT MATERIAL OR OTHER BACKFILL.
- SOIL FILTER MEDIA SHALL EITHER OPTION A OR OPTION B AT CONTRACTOR'S DISCRETION.
- DO NOT PLACE RAINGARDEN INTO SERVICE UNTIL IT HAS BEEN PLANTED AND ITS CONTRIBUTING AREAS STABILIZED.
- DO NOT DISCHARGE SEDIMENT-LADEN WATERS FROM CONSTRUCTION ACTIVITIES TO THE RAINGARDEN DURING ANY STAGE OF CONSTRUCTION.
- DO NOT TRAFFIC EXPOSED SURFACES OF RAINGARDEN WITH CONSTRUCTION EQUIPMENT. IF FEASIBLE, PERFORM EXCAVATION ACTIVITIES WITH EQUIPMENT POSITIONED OUTSIDE THE LIMITS OF THE BASIN.

MAINTENANCE REQUIREMENTS

- SYSTEMS SHOULD BE INSPECTED AT LEAST TWICE ANNUALLY, AND FOLLOWING ANY RAINFALL EXCEEDING 2.5 INCHES IN A 24-HOUR PERIOD, WITH MAINTENANCE OR REHABILITATION CONDUCTED AS A WARRANTED BY SUCH INSPECTION.
- PRETREATMENT MEASURES SHOULD BE INSPECTED AT LEAST TWICE ANNUALLY, AND CLEANED OF ACCUMULATED SEDIMENT AS WARRANTED BY INSPECTION, BUT NO LESS THAN ONCE ANNUALLY.
- AT LEAST ONCE ANNUALLY, SYSTEM SHOULD BE INSPECTED FOR DRAWDOWN TIME. IF BIORETENTION SYSTEM DOES NOT DRAIN WITHIN 72-HOURS FOLLOWING A RAINFALL EVENT, THEN A QUALIFIED PROFESSIONAL SHOULD ASSESS THE CONDITION OF THE FACILITY TO DETERMINE MEASURES REQUIRED TO RESTORE FILTRATION FUNCTION OR INFILTRATION FUNCTION (AS APPLICABLE), INCLUDING BUT NOT LIMITED TO REMOVAL OF ACCUMULATED SEDIMENTS OR RECONSTRUCTION OF THE FILTER MEDIA.
- VEGETATION SHOULD BE INSPECTED AT LEAST ANNUALLY, AND MAINTAINED IN HEALTHY CONDITION, INCLUDING, PRUNING, REMOVAL, AND REPLACEMENT OF DEAD OR DISEASED VEGETATION, AND REMOVAL OF INVASIVE SPECIES.

DESIGN REFERENCES

- UNH STORMWATER CENTER
- EPA (1999A)
- NEW HAMPSHIRE STORMWATER MANAGEMENT MANUAL, VOLUME 2, DECEMBER 2008 AS AMENDED.

TYPICAL GRASSED UNDERDRAIN SOIL FILTER

YARD DRAIN (PYD)

NOT TO SCALE

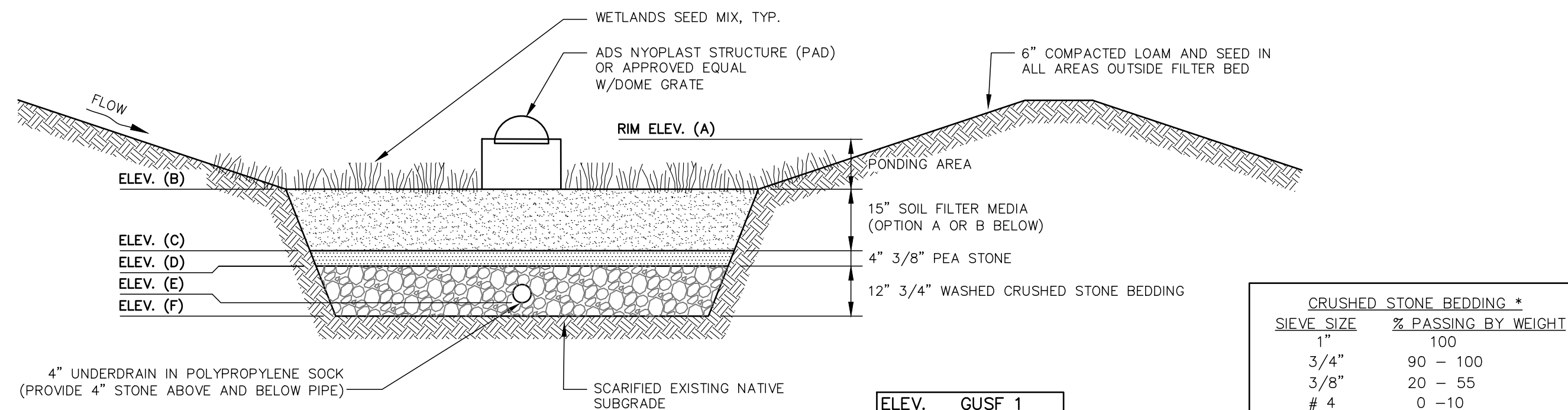

NOTES:

- WHEN CONTRACTOR EXCAVATES RAIN GARDEN AREA TO SUBGRADE, DESIGN ENGINEER SHALL PERFORM SUBSURFACE EVALUATION PRIOR TO THE PLACEMENT OF ANY SELECT MATERIAL OR OTHER BACKFILL.
- SOIL FILTER MEDIA SHALL EITHER OPTION A OR OPTION B AT CONTRACTOR'S DISCRETION.
- DO NOT PLACE RAINGARDEN INTO SERVICE UNTIL IT HAS BEEN PLANTED AND ITS CONTRIBUTING AREAS STABILIZED.
- DO NOT DISCHARGE SEDIMENT-LADEN WATERS FROM CONSTRUCTION ACTIVITIES TO THE RAINGARDEN DURING ANY STAGE OF CONSTRUCTION.
- DO NOT TRAFFIC EXPOSED SURFACES OF RAINGARDEN WITH CONSTRUCTION EQUIPMENT. IF FEASIBLE, PERFORM EXCAVATION ACTIVITIES WITH EQUIPMENT POSITIONED OUTSIDE THE LIMITS OF THE BASIN.

ELEV.	GUSE 1
A	33.75
B	32.25
C	31.00
D	30.67
E	30.00
F	29.67

CRUSHED STONE BEDDING *	
SIEVE SIZE	% PASSING BY WEIGHT
1"	100
3/4"	90 - 100
3/8"	20 - 55
# 4	0 - 10
# 8	0 - 5

* EQUIVALENT TO STANDARD STONE SIZE #67 - SECTION 703 OF NHDOT STANDARD SPECIFICATIONS

FILTER MEDIA MIXTURES			
Component Material	Percent of Mixture by Volume	Gradation of material	
		Sieve No.	Percent by Weight Passing Standard Sieve
Filter Media Option A			
ASTM C-33 concrete sand	50 to 55		
Loamy sand topsoil, with fines as indicated	20 to 30	200	15 to 25
Moderately fine shredded bark or wood fiber mulch, with fines as indicated	20 to 30	200	< 5
Filter Media Option B			
Moderately fine shredded bark or wood fiber mulch, with fines as indicated	20 to 30	200	< 5
Loamy coarse sand	70 to 80	10	85 to 100
		20	70 to 100
		60	15 to 40
		200	8 to 15

NOT TO SCALE

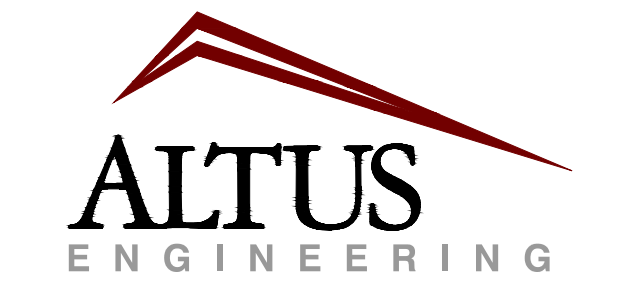

133 Court Street Portsmouth, NH 03801
(603) 433-2335 www.altus-eng.com



NOT FOR CONSTRUCTION

ISSUED FOR: APPROVAL

ISSUE DATE: JULY 10, 2023

NO.	DESCRIPTION	BY	DATE
0	REVIEW	EDW	08/03/22
1	RE-ALIGN DRAINAGE	EDW	07/10/23

DRAWN BY: RMB

APPROVED BY: EDW

DRAWING FILE: 5279SITE.DWG

SCALE: NOT TO SCALE

OWNER/APPLICANT:

BONNIE AND CLYDE LOGUE
27 SHAW ROAD
PORTSMOUTH, NH 03801

PROJECT:

RESIDENTIAL DEVELOPMENT

TAX MAP 223, LOTS 18 & 18-1
27 SHAW ROAD
PORTSMOUTH, NH

TITLE:

DETAIL SHEET

SHEET NUMBER:

C - 3

STORMWATER INSPECTION AND MAINTENANCE MANUAL

Bonnie and Clyde Logue Assessor's Map 223, Lot 18

OWNER AT TIME OF SUBDIVISION APPROVAL:

Bonnie and Clyde Logue
27 Shaw Road
Portsmouth, NH 03801

Proper inspection, maintenance, and repair are key elements in maintaining a successful stormwater management program on a developed property. Routine inspections ensure permit compliance and reduce the potential for deterioration of infrastructure or reduced water quality. The following responsible parties shall be in charge of managing the stormwater facilities:

RESPONSIBLE PARTIES:

Owner: Bonnie and Clyde Logue (603) 479-3981
Name Company Phone

Inspection: Bonnie and Clyde Logue (603) 479-3981
Name Company Phone

Maintenance: Bonnie and Clyde Logue (603) 479-3981
Name Company Phone

NOTES:

Inspection and maintenance responsibilities shall transfer to any future property owner(s).

This manual shall be updated as needed to reflect any changes related to any transfer of ownership and/or any delegation of inspection and maintenance responsibilities to another entity

INFILTRATION PONDS

Function – Infiltration ponds allow for the infiltration and treatment of stormwater runoff.

Maintenance

- Inspect annually and after significant rainfall events.
- If an infiltration-based practice does not completely drain within 72-hours following a rainfall event, then a qualified professional shall be retained to assess the condition of the facility to determine measures required to restore its filtration and/or infiltration function(s), including but not limited to removal of accumulated sediments and/or replacement or reconstruction of the structure.
- Remove any obstructions, litter and accumulated sediment or debris as warranted but no less than once a year.
- Mowing of any grassed area in or adjacent to a raingarden, including its berm, shall be performed at least twice per year (when areas are not inundated) to keep the vegetation in vigorous condition. The cut grass shall be removed to prevent the decaying organic litter from clogging the filter media or choking other vegetation.
- Select vegetation should be maintained in healthy condition. This may include pruning, removal and replacement of dead or diseased vegetation.
- Remove any hard wood growth from pond areas, including side slopes and berms.

STONE DRIP EDGE

Function – Drip edge accepts runoff from a peaked roof without gutter, allowing runoff to be detained at the drip line and filtered through the foundation backfill. The detention and filtration reduces the potential for runoff to the public drainage system, helps reduce flooding and minimizes the amount of pollutants flowing from the roof into a storm drain.

Maintenance

- Keep area free of vegetation and organic litter.

LANDSCAPED AREAS – ORGANIC FERTILIZER MANAGEMENT

Function – All fertilizer used on site shall be certified organic. Organic fertilizer management involves controlling the rate, timing and method of organic fertilizer application so that the nutrients are taken up by the plants thereby reducing the chance of polluting the surface and ground waters. Organic fertilizer management can be effective in reducing the amounts of phosphorus and nitrogen in runoff from landscaped areas, particularly lawns.

Maintenance

- Have the soil tested by your landscaper or local Soil Conservation Service for nutrient requirements and follow the recommendations.
- Do not apply organic fertilizer to frozen ground.
- Clean up any organic fertilizer spills.
- Do not allow organic fertilizer to be broadcast into water bodies.
- When organically fertilizing a lawn, water thoroughly, but do not create a situation where water runs off the surface of the lawn.



City of Portsmouth, New Hampshire

Subdivision Application Checklist

This subdivision application checklist is a tool designed to assist the applicant in the planning process and for preparing the application for Planning Board review. A pre-application conference with a member of the planning department is strongly encouraged as additional project information may be required depending on the size and scope. The applicant is cautioned that this checklist is only a guide and is not intended to be a complete list of all subdivision review requirements. Please refer to the Subdivision review regulations for full details.

Applicant Responsibilities (Section III.C): Applicable fees are due upon application submittal along with required number of copies of the Preliminary or final plat and supporting documents and studies. Please consult with Planning staff for submittal requirements.

Owner: Clyde Logue & Mary Duff Kastel Date Submitted: 7/5/23

Applicant: Same

Phone Number: 603-479-3981 E-mail: clyde3@gmail.com

Site Address 1: 27 Shaw Road Map: 223 Lot: 18

Site Address 2: Walker Bungalow Road Map: 223 Lot: 18 -1

Application Requirements			
<input checked="" type="checkbox"/>	Required Items for Submittal	Item Location (e.g. Page or Plan Sheet/Note #)	Waiver Requested
<input checked="" type="checkbox"/>	Completed Application form. (III.C.2-3)	Supplemental material	N/A
<input checked="" type="checkbox"/>	All application documents, plans, supporting documentation and other materials provided in digital Portable Document Format (PDF) on compact disc, DVD or flash drive. (III.C.4)	Supplemental materials	N/A

Requirements for Preliminary/Final Plat				
<input checked="" type="checkbox"/>	Required Items for Submittal	Item Location (e.g. Page/line or Plan Sheet/Note #)	Required for Preliminary / Final Plat	Waiver Requested
<input checked="" type="checkbox"/>	Name and address of record owner, any option holders, descriptive name of subdivision, engineer and/or surveyor or name of person who prepared the plat. (Section IV.1/V.1)	Plan title blocks (both sheets)	<input checked="" type="checkbox"/> Preliminary Plat <input checked="" type="checkbox"/> Final Plat	N/A

Requirements for Preliminary/Final Plat				
<input checked="" type="checkbox"/>	Required Items for Submittal	Item Location (e.g. Page/line or Plan Sheet/Note #)	Required for Preliminary / Final Plat	Waiver Requested
<input checked="" type="checkbox"/>	<p>Preliminary Plat Names and addresses of all adjoining property owners. (Section IV.2)</p> <p>Final Plat Names and addresses of all abutting property owners, locations of buildings within one hundred (100) feet of the parcel, and any new house numbers within the subdivision. (Section V.2)</p>	both sheets	<input checked="" type="checkbox"/> Preliminary Plat <input checked="" type="checkbox"/> Final Plat	N/A
<input checked="" type="checkbox"/>	North point, date, and bar scale. (Section IV.3/V3)	Required on all Plan Sheets	<input checked="" type="checkbox"/> Preliminary Plat <input checked="" type="checkbox"/> Final Plat	N/A
<input checked="" type="checkbox"/>	Zoning classification and minimum yard dimensions required. (Section IV.4/V.4)	both sheets	<input checked="" type="checkbox"/> Preliminary Plat <input checked="" type="checkbox"/> Final Plat	N/A
<input checked="" type="checkbox"/>	<p>Preliminary Plat Scale (not to be smaller than one hundred (100) feet = 1 inch) and location map (at a scale of 1" = 1000'). (Section IV.5)</p> <p>Final Plat Scale (not to be smaller than 1"=100'), Location map (at a scale of 1"=1,000') showing the property being subdivided and its relation to the surrounding area within a radius of 2,000 feet. Said location map shall delineate all streets and other major physical features that my either affect or be affected by the proposed development. (Section V.5)</p>	both sheets	<input checked="" type="checkbox"/> Preliminary Plat <input checked="" type="checkbox"/> Final Plat	N/A
<input checked="" type="checkbox"/>	Location and approximate dimensions of all existing and proposed property lines including the entire area proposed to be subdivided, the areas of proposed lots, and any adjacent parcels in the same ownership. (Section IV.6)	both sheets	<input checked="" type="checkbox"/> Preliminary Plat <input checked="" type="checkbox"/> Final Plat	
<input checked="" type="checkbox"/>	Dimensions and areas of all lots and any and all property to be dedicated or reserved for schools, parks, playgrounds, or other public purpose. Dimensions shall include radii and length of all arcs and calculated bearing for all straight lines. (Section V.6/ IV.7)	both sheets	<input checked="" type="checkbox"/> Preliminary Plat <input checked="" type="checkbox"/> Final Plat	N/A
<input checked="" type="checkbox"/>	Location, names, and present widths of all adjacent streets, with a designation as to whether public or private and approximate location of existing utilities to be used. Curbs and sidewalks shall be shown. (Section IV.8/V.7)	both sheets	<input checked="" type="checkbox"/> Preliminary Plat <input checked="" type="checkbox"/> Final Plat	

Requirements for Preliminary/Final Plat				
<input checked="" type="checkbox"/>	Required Items for Submittal	Item Location (e.g. Page/line or Plan Sheet/Note #)	Required for Preliminary / Final Plat	Waiver Requested
<input checked="" type="checkbox"/>	Location of significant physical features, including bodies of water, watercourses, wetlands, railroads, important vegetation, stone walls and soils types that may influence the design of the subdivision. (Section IV.9/V.8)	Both sheets	<input checked="" type="checkbox"/> Preliminary Plat <input checked="" type="checkbox"/> Final Plat	
<input checked="" type="checkbox"/>	Preliminary Plat Proposed locations, widths and other dimensions of all new streets and utilities, including water mains, storm and sanitary sewer mains, catch basins and culverts, street lights, fire hydrants, sewerage pump stations, etc. (Section IV.10) Final Plat Proposed locations and profiles of all proposed streets and utilities, including water mains, storm and sanitary sewer mains, catchbasins and culverts, together with typical cross sections. Profiles shall be drawn to a horizontal scale of 1"=50' and a vertical scale of 1"=5', showing existing centerline grade, existing left and right sideline grades, and proposed centerline grade. (Section V.9)	no new streets or utilities proposed	<input checked="" type="checkbox"/> Preliminary Plat <input checked="" type="checkbox"/> Final Plat	
<input checked="" type="checkbox"/>	When required by the Board, the plat shall be accompanied by profiles of proposed street grades, including extensions for a reasonable distance beyond the subject land; also grades and sizes of proposed utilities. (Section IV.10)	No new streets are proposed	<input checked="" type="checkbox"/> Preliminary Plat <input checked="" type="checkbox"/> Final Plat	
<input checked="" type="checkbox"/>	Base flood elevation (BFE) for subdivisions involving greater than five (5) acres or fifty (50) lots. (Section IV.11)	Note 4 both sheets	<input checked="" type="checkbox"/> Preliminary Plat <input checked="" type="checkbox"/> Final Plat	
<input checked="" type="checkbox"/>	For subdivisions of five (5) lots or more, or at the discretion of the Board otherwise, the preliminary plat shall show contours at intervals no greater than two (2) feet. Contours shall be shown in dotted lines for existing natural surface and in solid lines for proposed final grade, together with the final grade elevations shown in figures at all lot corners. If existing grades are not to be changed, then the contours in these areas shall be solid lines. (Section IV.12/ V.12)	Existing topography not required but provided. No alteration of contours proposed.	<input checked="" type="checkbox"/> Preliminary Plat <input checked="" type="checkbox"/> Final Plat	

Requirements for Preliminary/Final Plat				
<input checked="" type="checkbox"/>	Required Items for Submittal	Item Location (e.g. Page/line or Plan Sheet/Note #)	Required for Preliminary / Final Plat	Waiver Requested
<input checked="" type="checkbox"/>	Dates and permit numbers of all necessary permits from governmental agencies from which approval is required by Federal or State law. (Section V.10)	No state permitting required for subdivision. NHDES Shoreland Permit required for	<input type="checkbox"/> Preliminary Plat <input checked="" type="checkbox"/> Final Plat	
<input checked="" type="checkbox"/>	For subdivisions involving greater than five (5) acres or fifty (50) lots, the final plat shall show hazard zones and shall include elevation data for flood hazard zones. (Section V.11)	Not required. Provided. See note 4, both sheets.	<input type="checkbox"/> Preliminary Plat <input checked="" type="checkbox"/> Final Plat	
<input checked="" type="checkbox"/>	Location of all permanent monuments. (Section V.12)	Sheet A1	<input type="checkbox"/> Preliminary Plat <input checked="" type="checkbox"/> Final Plat	

General Requirements¹

<input checked="" type="checkbox"/>	Required Items for Submittal	Item Location (e.g. Page/line or Plan Sheet/Note #)	Waiver Requested
<input checked="" type="checkbox"/>	1. Basic Requirements: (VI.1)	Sheet A1	
<input checked="" type="checkbox"/>	a. Conformity to Official Plan or Map		
<input checked="" type="checkbox"/>	b. Hazards		
<input checked="" type="checkbox"/>	c. Relation to Topography		
<input checked="" type="checkbox"/>	d. Planned Unit Development	PUD not proposed	
<input checked="" type="checkbox"/>	2. Lots: (VI.2)	Meets zoning, sheet A1	
<input checked="" type="checkbox"/>	a. Lot Arrangement		
<input checked="" type="checkbox"/>	b. Lot sizes	Residential development not commercial or industrial	
<input type="checkbox"/>	c. Commercial and Industrial Lots		
<input checked="" type="checkbox"/>	3. Streets: (VI.3)	Not applicable - no streets proposed	
<input type="checkbox"/>	a. Relation to adjoining Street System		
<input type="checkbox"/>	b. Street Rights-of-Way		
<input type="checkbox"/>	c. Access		
<input type="checkbox"/>	d. Parallel Service Roads		
<input type="checkbox"/>	e. Street Intersection Angles		
<input type="checkbox"/>	f. Merging Streets		
<input type="checkbox"/>	g. Street Deflections and Vertical Alignment		
<input type="checkbox"/>	h. Marginal Access Streets		
<input type="checkbox"/>	i. Cul-de-Sacs		
<input type="checkbox"/>	j. Rounding Street Corners		
<input type="checkbox"/>	k. Street Name Signs		
<input type="checkbox"/>	l. Street Names		
<input type="checkbox"/>	m. Block Lengths		
<input type="checkbox"/>	n. Block Widths		
<input type="checkbox"/>	o. Grade of Streets		
<input type="checkbox"/>	p. Grass Strips		
<input checked="" type="checkbox"/>	4. Curbing: (VI.4)	not applicable	
<input checked="" type="checkbox"/>	5. Driveways: (VI.5)	to be submitted with lot development.	
<input checked="" type="checkbox"/>	6. Drainage Improvements: (VI.6)	to be submitted with lot development	
<input checked="" type="checkbox"/>	7. Municipal Water Service: (VI.7)	in street	
<input checked="" type="checkbox"/>	8. Municipal Sewer Service: (VI.8)	stub provided	
<input checked="" type="checkbox"/>	9. Installation of Utilities: (VI.9)	No new utility extensions proposed.	
<input type="checkbox"/>	a. All Districts		
<input type="checkbox"/>	b. Indicator Tape		
<input checked="" type="checkbox"/>	10. On-Site Water Supply: (VI.10)	NA	
<input checked="" type="checkbox"/>	11. On-Site Sewage Disposal Systems: (VI.11)	NA	
<input checked="" type="checkbox"/>	12. Open Space: (VI.12)	NA	
<input type="checkbox"/>	a. Natural Features		
<input type="checkbox"/>	b. Buffer Strips		
<input type="checkbox"/>	c. Parks		
<input type="checkbox"/>	d. Tree Planting		
<input checked="" type="checkbox"/>	13. Flood Hazard Areas: (VI.13)	NA	
<input type="checkbox"/>	a. Permits		
<input type="checkbox"/>	b. Minimization of Flood Damage		
<input type="checkbox"/>	c. Elevation and Flood-Proofing Records		
<input type="checkbox"/>	d. Alteration of Watercourses		
<input type="checkbox"/>	14. Erosion and Sedimentation Control (VI.14)		

<input checked="" type="checkbox"/>	Required Items for Submittal	Item Location (e.g. Page/line or Plan Sheet/Note #)	Waiver Requested
<input checked="" type="checkbox"/>	15. Easements (VI.15)	on sheet A1	
<input type="checkbox"/>	a. Utilities		
<input checked="" type="checkbox"/>	b. Drainage		
<input checked="" type="checkbox"/>	16. Monuments: (VI.16)	Sheet A1	
<input checked="" type="checkbox"/>	17. Benchmarks: (VI.17)	Utility Pole sheet C1, top center	
<input checked="" type="checkbox"/>	18. House Numbers (VI.18)	to be provided	

Design Standards			
	Required Items for Submittal	Indicate compliance and/or provide explanation as to alternative design	Waiver Requested
<input checked="" type="checkbox"/>	1. Streets have been designed according to the design standards required under Section (VII.1). a. Clearing b. Excavation c. Rough Grade and Preparation of Sub-Grade d. Base Course e. Street Paving f. Side Slopes g. Approval Specifications h. Curbing i. Sidewalks j. Inspection and Methods	NA	
<input checked="" type="checkbox"/>	2. Storm water Sewers and Other Drainage Appurtenances have been designed according to the design standards required under Section (VII.2). a. Design b. Standards of Construction	NA	
<input checked="" type="checkbox"/>	3. Sanitary Sewers have been designed according to the design standards required under Section (VII.3). a. Design b. Lift Stations c. Materials d. Construction Standards	NA	
<input checked="" type="checkbox"/>	4. Water Mains and Fire Hydrants have been designed according to the design standards required under Section (VII.4). a. Connections to Lots b. Design and Construction c. Materials d. Notification Prior to Construction	NA	

Applicant's/Representative's Signature: *Ric D. Weinreb, PE* Date: 7/5/23

¹ See City of Portsmouth, NH Subdivision Rules and Regulations for details.
Subdivision Application Checklist/January 2018

Letter of Authorization

I, Clyde Logue & Mary Duff Kastel, hereby authorize Altus Engineering, LLC of Portsmouth, NH to represent us in all matters concerning the engineering and related permitting of improvements to the property located at 27 Shaw Road and Walker Bungalow Road in Portsmouth, NH on Assessors Map 223, Lots 18 and 18-1. This authorization shall include any signatures required for Federal, State and Municipal permit applications.

Signature



Mary Duff Kastel

July 7, 2023
Date

Witness

Clyde Logue
Print Name

July 7, 2023
Date

Signature

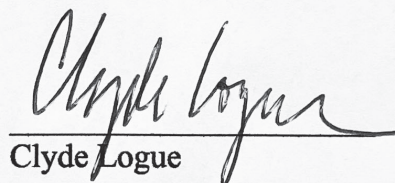

Clyde Logue

July 7, 2023
Date

Witness

Mary Kastel
Print Name

July 7, 2023
Date