

Findings of Fact | Subdivision Rules and Regulations

City of Portsmouth Planning Board

Date: April 16, 2026

Property Address: 0 South Street

Application #: LU-26-19

Decision: Approve Deny Approve with Conditions

Findings of Fact:

Per RSA 676:3, I: The local land use board shall issue a final written decision which either approves or disapproves an application for a local permit and make a copy of the decision available to the applicant. **The decision shall include specific written findings of fact that support the decision. Failure of the board to make specific written findings of fact supporting a disapproval shall be grounds for automatic reversal and remand by the superior court upon appeal, in accordance with the time periods set forth in RSA 677:5 or RSA 677:15, unless the court determines that there are other factors warranting the disapproval.** If the application is not approved, the board shall provide the applicant with written reasons for the disapproval. If the application is approved with conditions, the board shall include in the written decision a detailed description of the all conditions necessary to obtain final approval.

	Subdivision Review Criteria	Finding (Meets Standards/ Requirements)	Supporting Information
1	Subdivision Rules and Regulations III. D. 1 The Board shall act to deny any application which is not in compliance with Section IV or V as appropriate. SECTION IV - REQUIREMENTS FOR PRELIMINARY PLAT	Meets Does Not Meet	The project meets all the applicable Ordinances, Codes, and Regulations.
2	SECTION V - REQUIREMENTS FOR FINAL PLAT	Meets Does Not Meet	The final plan will be submitted on mylar. The plan includes all of the information required for final approval and meets the standard for recording at the registry of deeds.
3	SECTION VI - GENERAL REQUIREMENTS	Meets Does Not Meet	The application meets the general requirements of the regulations. The application was recommended approval by TAC on March 3, 2026.
4	SECTION VII - DESIGN STANDARDS	Meets Does Not Meet	The development does not require the construction of any streets or public ways for access. Utility connections, drainage and access have been reviewed by TAC. TAC recommended approval on March 3, 2026.

	Subdivision Review Criteria	Finding (Meets Standards/ Requirements)	Supporting Information
5	<u>Other Board Findings:</u>		

DRAFT



HALEY WARD®

APPLICATION FOR SUBDIVISION

**TO THE CITY OF PORTSMOUTH
FOR RICHARDS AVENUE & SOUTH STREET**

Map 112, Lot 24A | Portsmouth, NH

APPLICANT:

Chinburg Development

3 Penstock Way, Newmarket, NH 03857

March 25, 2026
JN: 5010220.003

REPORT PREPARED BY:

Haley Ward, Inc.

200 Griffin Road, Unit 14 | Portsmouth, NH 03801



March 25, 2026

Rick Chellman, Planning Board Chair
City of Portsmouth
1 Junkins Avenue
Portsmouth, NH 03801

**RE: Request for Planning Board Review
Richards Avenue & South Street
Subdivision Application**

Dear Mr. Chellman and Planning Board Members,

On behalf of Chinburg Development, we are pleased to submit the attached **Subdivision Application** for the above-mentioned project and request that we be placed on the agenda for your **April 16, 2026** Planning Board Meeting. The property is shown on the City of Portsmouth Assessors Map 112 as Lot 24A. The project was recently presented to the Portsmouth Technical Advisory Committee (TAC) and was approved at their March 3, 2026 meeting.

PROJECT OVERVIEW

The project consists of subdividing the existing lot located at Richards Avenue and South Street into two lots for residential development. The existing site has a total area of 17,459 square feet. The site is currently undeveloped with a fenced perimeter, grass and various trees. Once subdivided, the project includes the construction of a single-family dwelling with associated walkways and driveways on each lot. Preliminary building footprints, site layouts, drainage and utilities are shown in the attached submittal to show compliance with the ordinance. Final layouts and design will be prepared and submitted with the building permits. The development of the site will comply with the applicable design, safety, and operational standards, including building code compliance. We believe that the residential development will complement the surrounding neighborhood.

SITE ZONING

The project is within the City of Portsmouth General Residence A (GRA) District which allows for residential development. The proposed project is consistent with the surrounding neighborhood which is predominantly single family residential. As proposed the subdivision meets all zoning requirements.



PARKING

Each residence will have a two car garage in addition to two driveway parking spaces for a total of four parking spaces per dwelling.

VEHICULAR AND PEDESTRIAN CIRCULATION

Each residence will be accessed by their own 20-foot-wide paved driveway with a turnaround. Pedestrian access will be provided by new walkways to the front door of each residence.

SCREENING AND LANDSCAPING

The site landscaping is still in the preliminary design stages but will generally feature perimeter plantings to provide screening for the proposed residences. Supplemental landscaping is proposed around the houses and patios. All landscaping will be consistent with traditional local residential design and will match the surrounding neighborhood.

WATER AND SEWAGE SYSTEMS

Each residence will be served by municipal water located within South Street. Each residence will be served by municipal sewer located in Richards Avenue. An easement is provided at the rear of Lot 1 to allow for the installation of sewer to Lot 2

STORMWATER MANAGEMENT

A Ferguson R-Tank MD (or approved equal) underground stormwater detention system is proposed to collect runoff from impervious surfaces and provided a reduction in runoff rates due to the increased impervious cover. The existing site predominantly drains to the west into the Richards Avenue stormwater system with a small portion draining offsite onto abutting properties to the north. In the developed condition, stormwater flow rates are reduced to pre-development flow rates. See the attached Stormwater Management and Erosion Control Plan for additional information. The stormwater design is preliminary and intended to show compliance with the subdivision regulations. An updated design will be provided with the building permit submittal.

SITE LIGHTING

Site lighting will be designed at minimum levels to provide a welcoming and safe pedestrian experience and not create excess lighting within the neighborhood.

SITE UTILITIES

Natural gas, electric, and communications services will be installed underground from South Street to serve the residences.



SOLID WASTE

Solid waste will be collected through curb side pickup.

SUBMISSION

The submission includes Plans, the Subdivision Application Checklist, a Tax Map, an Aerial Map and a Drainage Management and Erosion Control Plan.

The following drawings are included in our submission:

- C000 – Cover Sheet
- C001 – General Notes, Legend & Abbreviations
- V101 – Conditions Plan – This plan shows the existing conditions at the site.
- Subdivision Plan – This plan shows the proposed subdivision and easement.
- C101 – Site Layout Plan – This plan shows the proposed site development.
- C102 – Grading, Drainage, & Utility Plan – This plan shows the proposed stormwater improvements and utilities.
- C501 & C502 – Construction Details
- C701 & C702 – Pre- & Post-Development Hydrology Plans – These plans show the existing and proposed drainage areas and flow paths.

We look forward to the Planning Boards's review of this submission and to presenting the project in person at your upcoming meeting.

Sincerely,
Haley Ward, Inc.

Shawn Tobey, PE
Southern Maine & New Hampshire Land Development Manager



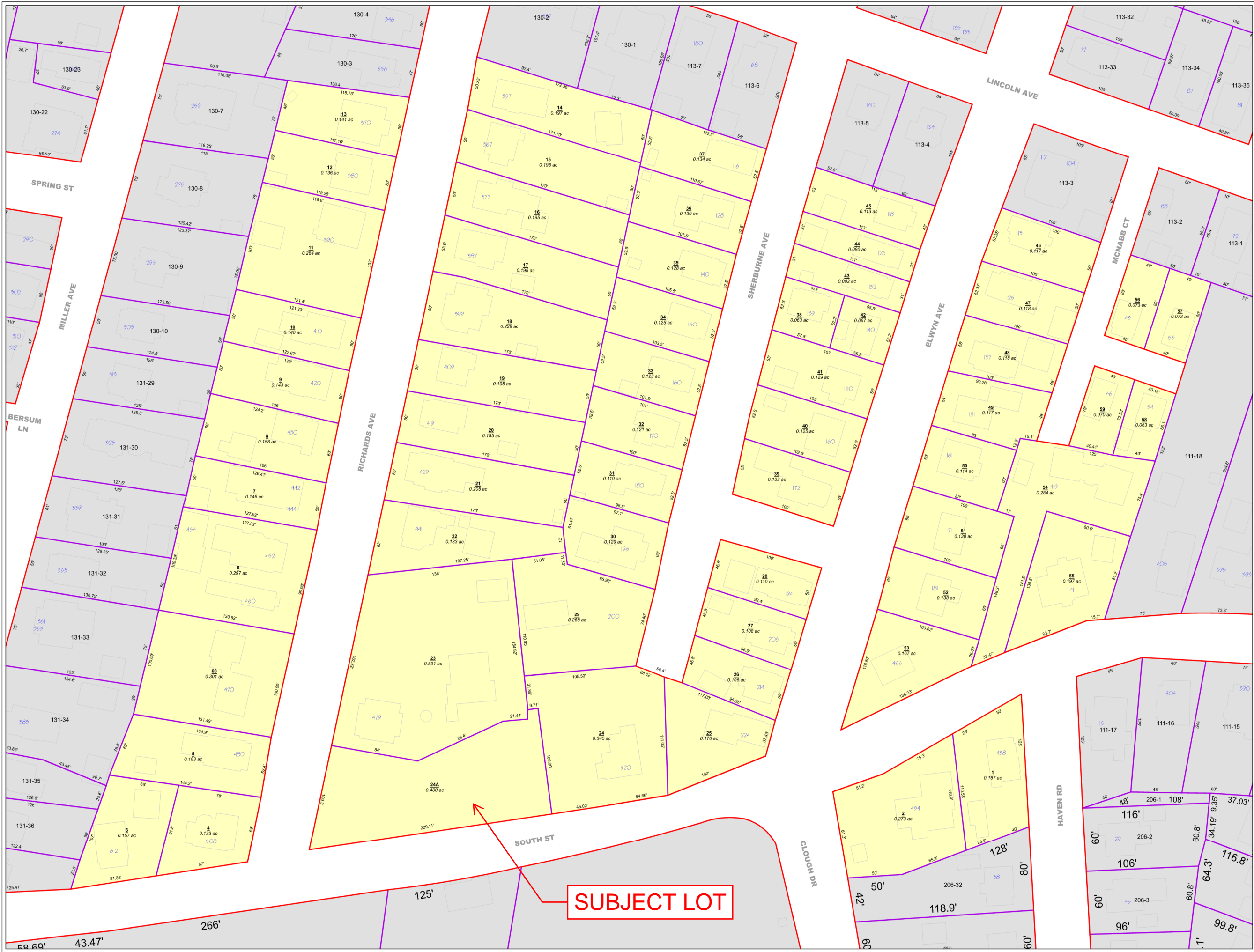

Partial Legend
 See the cover sheet for the complete legend.

7-5A Lot or lot-unit number
 2.56 ac Parcel area in acres (ac) or square feet (sf)
 123 Address number
 233-137 Parcel number from a neighboring map
 68' Parcel line dimension
 SIMS AVE Street name

Parcel/Parcel boundary
 Parcel/ROW boundary
 Water boundary
 Structure (1994 data)

Parcel covered by this map
 Parcel from a neighboring map (see other map for current status)

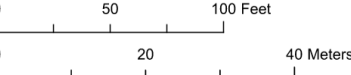

This map is for assessment purposes only. It is not intended for legal description or conveyance. Parcels are mapped as of April 1. Building footprints are 2006 data and may not represent current structures. Streets appearing on this map may be paper (unbuilt) streets. Lot numbers take precedence over address numbers. Address numbers shown on this map may not represent posted or legal addresses.

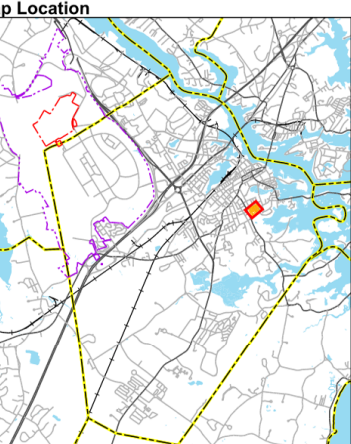
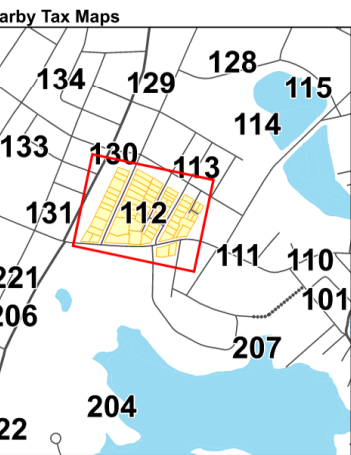

Portsmouth, New Hampshire
 2025
Tax Map 112

SUBJECT LOT



**MAP FOR REFERENCE ONLY
NOT A LEGAL DOCUMENT**

City of Portsmouth, NH makes no claims and no warranties, expressed or implied, concerning the validity or accuracy of the GIS data presented on this map.

Geometry updated 10/23/2025

Print map scale is approximate. Critical layout or measurement activities should not be done using this resource.

1" = 87.81194256402001 ft
2006-33



HALEY WARD®

STORMWATER MANAGEMENT AND EROSION CONTROL PLAN

**TO THE CITY OF PORTSMOUTH
FOR RICHARDS AVENUE & SOUTH STREET**
Map 112, Lot 24A | Portsmouth, NH

APPLICANT:
Chinburg Development
3 Penstock Way
Newmarket, NH 03847



February 13, 2026
JN: 5010220.003

REPORT PREPARED BY:
Haley Ward, Inc.
200 Griffin Road, Unit 14 | Portsmouth, NH 03801



EXECUTIVE SUMMARY

This drainage analysis examines the pre-development (existing) and post-development (proposed) stormwater drainage patterns for the proposed residential redevelopment project at the intersection of Richards Avenue & South Street in Portsmouth, NH. The site is shown on the City of Portsmouth Assessor's Tax Map 112 as Lot 24A. The total size of the existing lot is approximately 17,459 square feet.

The development will subdivide the existing lot and provide for the construction of two (2) single-family homes, with associated landscaping, utilities, and driveways. The new buildings will be serviced by public water and sewer. The development has the potential to increase stormwater runoff to adjacent properties and therefore must be designed in a manner to prevent that occurrence. This will be done primarily by capturing stormwater runoff and routing it through appropriate stormwater facilities, designed to ensure that there will be no significant increase in peak runoff from the site as a result of this project.

Due to the number of lots created and the size of the project, post-construction stormwater management design standards and enhanced stormwater treatment standards are not applicable. The intent of this stormwater design is to comply with the requirements of Section 7.6.1.4 of the City of Portsmouth Site Plan Review Ordinance as related to post-development peak rate of runoff reduction.

INTRODUCTION / PROJECT DESCRIPTION

This drainage report is designed to assist the owner, planning board, contractor, regulatory reviewer, and others in understanding the impact of the proposed development project on local surface water runoff. Bounding the site to the north and east are developed residential properties. The site is bound to the south and west by Richards Avenue and South Street.

The proposed development will include the construction of single-family homes, decks, driveways, sidewalks, and patios causing an increase in impervious cover. To offset the increase, an underground stormwater detention system has been designed for each lot. The detention systems will collect all roof runoff from either drip strips with underdrains or gutters with downspouts. The detention systems will also collect stormwater runoff from the driveways through catch basins. As a placeholder, the underground detention systems are based on a series of Ferguson R-Tank HD units wrapped in crushed stone with controlled outlet structures. The site layouts and drainage designs are preliminary and intended for planning purposes only to show compliance with the zoning ordinances.



The applicant shall submit final site/stormwater design plans with an Operations and Maintenance Plan for review and approval as part of the Building Permit application. This report includes information about the existing site necessary to analyze stormwater runoff and to design any required mitigation. The report includes maps of pre-development and post-development watersheds, subcatchment areas and calculations of runoff. The report will provide a narrative of the stormwater runoff and describe numerically and graphically the surface water runoff patterns for this site. Proposed stormwater management structures and methods will also be described, as well as erosion and sediment control practices. To fully understand the proposed site development the reader should also review the complete site plan set in addition to this report.

METHODOLOGY

“Extreme Precipitation” values from The Northeast Regional Climate Center (Cornell University) have been used for modeling purposes. These values have been used in this analysis, with a 15% addition to comply with local ordinances.

This report uses the US Soil Conservation Service (SCS) Method for estimating stormwater runoff. The SCS method is published in The National Engineering Handbook (NEH), Section 4 “Hydrology” and includes the Technical Release No. 20, (TR-20) “Computer Program for Project Formulation Hydrology”, and Technical Release No. 55 (TR-55) “Urban Hydrology for Small Watersheds” methods. This report uses the HydroCAD version 10.20 program, written by HydroCAD Software Solutions LLC, Chocorua, N.H., to apply these methods for the calculation of runoff and for pond modeling. Rainfall data and runoff curve numbers are taken from “The Stormwater Management and Erosion Control Handbook for Urban and Developing Areas in New Hampshire.”

Time of Concentration (T_c) is calculated by entering measured flow path data such as flow path type, length, slope and surface characteristics into the HydroCAD program. For the purposes of this report, a minimum time of concentration of 5 minutes is used.

The storm events used for the calculations in this report are the 2-year, 10-year, and 50-year (24-hour) storms. Watershed basin boundaries have been delineated using topographic maps prepared by Haley Ward and field observations to confirm.



SITE SPECIFIC INFORMATION

Based on the United States Department of Agriculture (USDA) Natural Resources Conservation Service (NRCS), Soil Survey of Rockingham County, New Hampshire the site is made up of one soil type:

Soil Symbol	Soil Name and Slopes
799	Urban land-Canton complex (3-15% slopes)

A “Type B” hydrologic rating was assumed for the stormwater modelling.

The physical characteristics of the existing lot consist of slopes from 3 to 20%, with the lot generally sloping down from South Street to the northwest. Elevations on the site range from 21 to 29 feet above mean sea level. The western portion of the site drains to the city stormwater system within Richards Avenue. The eastern portion of the site drains to north onto abutting residential properties.

According to the Federal Emergency Management Agency (FEMA) Flood Insurance Rate Map, Panel 33015C0259F, the project site is not in a special flood hazard area.

There are no protected natural resources on or directly adjacent to the subject property.

PRE-DEVELOPMENT DRAINAGE

In the pre-development condition, the site has been analyzed as two (2) subcatchment watershed basins based on localized topography and discharge location. A Pre-Development Hydrology map and HydroCAD model results have been provided.

Subcatchment 1 represents the western half of the site and includes undeveloped grass area. This area drains northwest and into the City’s stormwater system within Richards Avenue. (Summation Point 1.)

Subcatchment 2 represents the eastern half of the site which drains offsite to the north onto abutting residential properties. (Summation Point 2.)

POST-DEVELOPMENT DRAINAGE

The proposed development has been designed to match the pre-development drainage patterns to the greatest extent feasible. In the post-development condition, the site has been analyzed as four (4) subcatchment basins. A Post-Development Hydrology map and HydroCAD model results have been provided.



Subcatchment 1A continues to represent the reduced western portion of the site draining to the Richards Avenue stormwater system

Subcatchment 1B represents the proposed dwelling and driveway draining to the underground detention system of proposed Lot 1.

Subcatchment 1C represents the proposed dwelling and driveway draining to the underground detention system of proposed Lot 2.

Subcatchment 2 continues to represent the reduced eastern half of the site which drains offsite to the north onto abutting residential properties.

RUNOFF COMPARISON

Table 1: Pre-Development to Post-Development Comparison

Design Point	Q2 (CFS)		Q10 (CFS)		Q50 (CFS)		Description
	Pre	Post	Pre	Post	Pre	Post	
SP1	0.17	0.16	0.53	0.53	1.22	1.17	Richards Ave Stormwater System
SP2	0.08	0.08	0.25	0.21	0.57	0.47	Offsite Flow to the Northeast

As shown in Table 1, post-development runoff rates are similar or less than those observed under pre-development conditions.

EROSION AND SEDIMENT CONTROL PRACTICES

During construction, the potential for erosion exists due to stormwater runoff. The contractor will be required to inspect and maintain all necessary erosion control measures, as well as installing any additional measures as required. All erosion control practices shall conform to "The Stormwater Management and Erosion Control Handbook for Urban and Developing Areas in New Hampshire." Some examples of erosion and sediment control measures to be utilized for this project during construction may include:

- Silt Soxx (or approved alternative) located at the toe of disturbed slopes
- Stabilized construction entrance at access point to the site
- Temporary mulching and seeding for disturbed areas
- Spraying water over disturbed areas to minimize wind erosion



After construction, permanent stabilization will be accomplished by permanent seeding, landscaping, and surfacing the access drives and parking areas with asphalt paving and other areas with impervious walkways.

CONCLUSION

The proposed development has been designed to match the pre-development drainage patterns to the greatest extent feasible. With the design of the underground detention systems, the post-development runoff rates are effectively equivalent to the pre-development runoff rates. Erosion and sediment control practices will be implemented for both the temporary condition during construction and for final stabilization after construction. Therefore, there are no negative impacts to downstream receptors or adjacent properties anticipated as a result of this project.

REFERENCES

1. Comprehensive Environmental Inc. and New Hampshire Department of Environmental Services. *New Hampshire Stormwater Manual (Volumes 1, 2 and 3)*, December 2008 (Revision 1.0).
2. Minnick, E.L. and H.T. Marshall. *Stormwater Management and Erosion and Sediment Control Handbook for Urban and Developing Areas in New Hampshire*, prepared by Rockingham County Conservation District, prepared for New Hampshire Department of Environmental Services, in cooperation with USDA Soil Conservation Service, August 1992.
3. HydroCAD Software Solution, LLC. *HydroCAD Stormwater Modeling System Version 10.20* copyright 2013.

Extreme Precipitation Tables

Northeast Regional Climate Center

Data represents point estimates calculated from partial duration series. All precipitation amounts are displayed in inches.

Metadata for Point	
Smoothing	Yes
State	
Location	
Latitude	43.065 degrees North
Longitude	70.76 degrees West
Elevation	10 feet
Date/Time	Mon Feb 09 2026 10:52:59 GMT-0500 (Eastern Standard Time)

Extreme Precipitation Estimates

	5min	10min	15min	30min	60min	120min		1hr	2hr	3hr	6hr	12hr	24hr	48hr		1day	2day	4day	7day	10day	
1yr	0.26	0.40	0.50	0.65	0.82	1.04	1yr	0.70	0.98	1.21	1.56	2.03	2.66	2.93	1yr	2.36	2.82	3.23	3.95	4.56	1yr
2yr	0.32	0.50	0.62	0.82	1.02	1.30	2yr	0.88	1.18	1.52	1.94	2.49	3.22	3.58	2yr	2.85	3.44	3.95	4.69	5.34	2yr
5yr	0.37	0.58	0.73	0.98	1.25	1.61	5yr	1.08	1.47	1.89	2.43	3.14	4.07	4.59	5yr	3.61	4.41	5.05	5.95	6.72	5yr
10yr	0.41	0.65	0.82	1.12	1.45	1.89	10yr	1.25	1.73	2.23	2.90	3.76	4.88	5.54	10yr	4.32	5.33	6.10	7.13	7.99	10yr
25yr	0.48	0.76	0.97	1.34	1.78	2.34	25yr	1.53	2.15	2.78	3.64	4.75	6.18	7.12	25yr	5.47	6.84	7.83	9.05	10.07	25yr
50yr	0.54	0.86	1.10	1.54	2.08	2.76	50yr	1.79	2.53	3.30	4.33	5.67	7.40	8.60	50yr	6.55	8.27	9.45	10.84	12.00	50yr
100yr	0.60	0.97	1.25	1.77	2.42	3.26	100yr	2.09	2.98	3.91	5.17	6.78	8.87	10.40	100yr	7.85	10.00	11.42	13.00	14.31	100yr
200yr	0.68	1.10	1.43	2.05	2.83	3.85	200yr	2.44	3.52	4.63	6.14	8.10	10.63	12.58	200yr	9.41	12.09	13.80	15.59	17.06	200yr
500yr	0.80	1.32	1.72	2.49	3.49	4.78	500yr	3.01	4.39	5.78	7.73	10.25	13.51	16.18	500yr	11.96	15.56	17.74	19.84	21.54	500yr

Lower Confidence Limits

	5min	10min	15min	30min	60min	120min		1hr	2hr	3hr	6hr	12hr	24hr	48hr		1day	2day	4day	7day	10day	
1yr	0.23	0.36	0.44	0.59	0.72	0.88	1yr	0.63	0.86	0.92	1.33	1.68	2.24	2.50	1yr	1.99	2.41	2.87	3.19	3.91	1yr
2yr	0.31	0.49	0.60	0.81	1.00	1.19	2yr	0.86	1.16	1.37	1.82	2.33	3.07	3.46	2yr	2.71	3.33	3.83	4.56	5.09	2yr
5yr	0.35	0.54	0.67	0.92	1.17	1.40	5yr	1.01	1.37	1.61	2.12	2.73	3.80	4.20	5yr	3.36	4.04	4.73	5.55	6.26	5yr
10yr	0.39	0.59	0.74	1.03	1.33	1.60	10yr	1.15	1.57	1.80	2.39	3.05	4.38	4.88	10yr	3.88	4.69	5.46	6.43	7.22	10yr
25yr	0.44	0.67	0.83	1.19	1.56	1.90	25yr	1.35	1.86	2.10	2.75	3.53	4.74	5.91	25yr	4.20	5.69	6.68	7.83	8.71	25yr
50yr	0.48	0.73	0.91	1.31	1.77	2.17	50yr	1.53	2.12	2.35	3.07	3.92	5.36	6.83	50yr	4.74	6.57	7.77	9.09	10.06	50yr
100yr	0.54	0.81	1.02	1.47	2.01	2.47	100yr	1.74	2.41	2.63	3.41	4.34	6.03	7.89	100yr	5.34	7.58	9.03	10.56	11.61	100yr
200yr	0.59	0.89	1.13	1.64	2.28	2.82	200yr	1.97	2.75	2.94	3.77	4.78	6.77	9.11	200yr	5.99	8.76	10.50	12.30	13.43	200yr
500yr	0.69	1.02	1.32	1.91	2.72	3.36	500yr	2.35	3.29	3.41	4.30	5.44	7.88	11.01	500yr	6.97	10.58	12.81	15.06	16.27	500yr

Upper Confidence Limits

	5min	10min	15min	30min	60min	120min		1hr	2hr	3hr	6hr	12hr	24hr	48hr		1day	2day	4day	7day	10day	
1yr	0.29	0.44	0.54	0.72	0.89	1.08	1yr	0.77	1.06	1.26	1.74	2.20	2.99	3.17	1yr	2.64	3.05	3.59	4.38	5.05	1yr
2yr	0.34	0.52	0.64	0.87	1.07	1.27	2yr	0.92	1.24	1.48	1.96	2.51	3.43	3.71	2yr	3.03	3.57	4.10	4.85	5.64	2yr
5yr	0.40	0.62	0.77	1.05	1.34	1.62	5yr	1.15	1.59	1.88	2.54	3.25	4.35	4.97	5yr	3.85	4.78	5.39	6.38	7.17	5yr
10yr	0.47	0.72	0.89	1.25	1.61	1.98	10yr	1.39	1.93	2.28	3.11	3.96	5.35	6.21	10yr	4.73	5.97	6.83	7.85	8.76	10yr
25yr	0.58	0.88	1.09	1.56	2.05	2.57	25yr	1.77	2.52	2.96	4.07	5.15	7.78	8.35	25yr	6.88	8.03	9.15	10.35	11.42	25yr
50yr	0.67	1.02	1.27	1.83	2.47	3.13	50yr	2.13	3.06	3.60	5.00	6.33	9.74	10.46	50yr	8.62	10.06	11.44	12.74	13.97	50yr
100yr	0.79	1.20	1.50	2.16	2.97	3.82	100yr	2.56	3.73	4.38	6.16	7.77	12.18	13.10	100yr	10.78	12.60	14.30	15.71	17.10	100yr
200yr	0.93	1.39	1.77	2.56	3.57	4.66	200yr	3.08	4.56	5.34	7.59	9.55	15.28	16.43	200yr	13.52	15.80	17.90	19.36	20.93	200yr
500yr	1.15	1.71	2.20	3.20	4.55	6.05	500yr	3.92	5.92	6.94	10.03	12.57	20.63	22.17	500yr	18.26	21.32	24.09	25.52	27.35	500yr

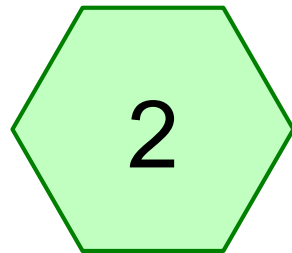
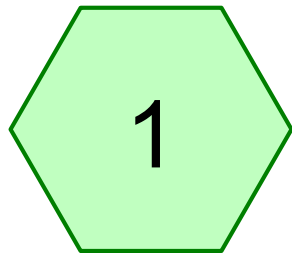
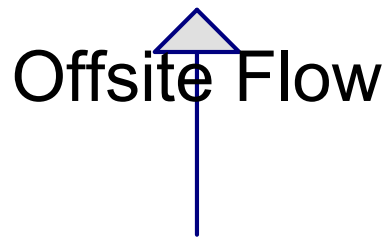
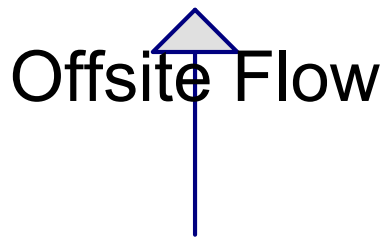

Grass

Grass

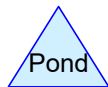
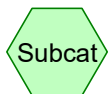

5010220.003-Pre

Prepared by Haley Ward

HydroCAD® 10.20-7a s/n 00641 © 2025 HydroCAD Software Solutions LLC

Printed 2/11/2026

Page 2

Area Listing (all nodes)

Area (sq-ft)	CN	Description (subcatchment-numbers)
17,460	61	>75% Grass cover, Good, HSG B (1, 2)

Soil Listing (all nodes)

Area (sq-ft)	Soil Group	Subcatchment Numbers
0	HSG A	
17,460	HSG B	1, 2
0	HSG C	
0	HSG D	
0	Other	

5010220.003-Pre

Prepared by Haley Ward

HydroCAD® 10.20-7a s/n 00641 © 2025 HydroCAD Software Solutions LLC

Type III 24-hr 2-Yr Rainfall=3.70"

Printed 2/11/2026

Page 4

Time span=0.00-24.00 hrs, dt=0.05 hrs, 481 points
Runoff by SCS TR-20 method, UH=SCS, Weighted-CN
Reach routing by Stor-Ind+Trans method - Pond routing by Stor-Ind method

Subcatchment1: Grass

Runoff Area=11,895 sf 0.00% Impervious Runoff Depth>0.66"
Tc=5.0 min CN=61 Runoff=0.17 cfs 659 cf

Subcatchment2: Grass

Runoff Area=5,565 sf 0.00% Impervious Runoff Depth>0.66"
Tc=5.0 min CN=61 Runoff=0.08 cfs 308 cf

Reach SP1: Offsite Flow

Inflow=0.17 cfs 659 cf
Outflow=0.17 cfs 659 cf

Reach SP2: Offsite Flow

Inflow=0.08 cfs 308 cf
Outflow=0.08 cfs 308 cf

5010220.003-Pre

Prepared by Haley Ward

HydroCAD® 10.20-7a s/n 00641 © 2025 HydroCAD Software Solutions LLC

Type III 24-hr 10-Yr Rainfall=5.61"

Printed 2/11/2026

Page 5

Time span=0.00-24.00 hrs, dt=0.05 hrs, 481 points
Runoff by SCS TR-20 method, UH=SCS, Weighted-CN
Reach routing by Stor-Ind+Trans method - Pond routing by Stor-Ind method

Subcatchment1: Grass

Runoff Area=11,895 sf 0.00% Impervious Runoff Depth>1.75"
Tc=5.0 min CN=61 Runoff=0.53 cfs 1,732 cf

Subcatchment2: Grass

Runoff Area=5,565 sf 0.00% Impervious Runoff Depth>1.75"
Tc=5.0 min CN=61 Runoff=0.25 cfs 810 cf

Reach SP1: Offsite Flow

Inflow=0.53 cfs 1,732 cf
Outflow=0.53 cfs 1,732 cf

Reach SP2: Offsite Flow

Inflow=0.25 cfs 810 cf
Outflow=0.25 cfs 810 cf

Summary for Subcatchment 1: Grass

Runoff = 0.53 cfs @ 12.09 hrs, Volume= 1,732 cf, Depth> 1.75"
 Routed to Reach SP1 : Offsite Flow

Runoff by SCS TR-20 method, UH=SCS, Weighted-CN, Time Span= 0.00-24.00 hrs, dt= 0.05 hrs
 Type III 24-hr 10-Yr Rainfall=5.61"

Area (sf)	CN	Description
11,895	61	>75% Grass cover, Good, HSG B
11,895		100.00% Pervious Area

Tc (min)	Length (feet)	Slope (ft/ft)	Velocity (ft/sec)	Capacity (cfs)	Description
5.0					Direct Entry,

Summary for Subcatchment 2: Grass

Runoff = 0.25 cfs @ 12.09 hrs, Volume= 810 cf, Depth> 1.75"
 Routed to Reach SP2 : Offsite Flow

Runoff by SCS TR-20 method, UH=SCS, Weighted-CN, Time Span= 0.00-24.00 hrs, dt= 0.05 hrs
 Type III 24-hr 10-Yr Rainfall=5.61"

Area (sf)	CN	Description
5,565	61	>75% Grass cover, Good, HSG B
5,565		100.00% Pervious Area

Tc (min)	Length (feet)	Slope (ft/ft)	Velocity (ft/sec)	Capacity (cfs)	Description
5.0					Direct Entry,

Summary for Reach SP1: Offsite Flow

Inflow Area = 11,895 sf, 0.00% Impervious, Inflow Depth > 1.75" for 10-Yr event
 Inflow = 0.53 cfs @ 12.09 hrs, Volume= 1,732 cf
 Outflow = 0.53 cfs @ 12.09 hrs, Volume= 1,732 cf, Atten= 0%, Lag= 0.0 min

Routing by Stor-Ind+Trans method, Time Span= 0.00-24.00 hrs, dt= 0.05 hrs

Summary for Reach SP2: Offsite Flow

Inflow Area = 5,565 sf, 0.00% Impervious, Inflow Depth > 1.75" for 10-Yr event
 Inflow = 0.25 cfs @ 12.09 hrs, Volume= 810 cf
 Outflow = 0.25 cfs @ 12.09 hrs, Volume= 810 cf, Atten= 0%, Lag= 0.0 min

Routing by Stor-Ind+Trans method, Time Span= 0.00-24.00 hrs, dt= 0.05 hrs

5010220.003-Pre

Prepared by Haley Ward

HydroCAD® 10.20-7a s/n 00641 © 2025 HydroCAD Software Solutions LLC

Type III 24-hr 50-Yr Rainfall=8.51"

Printed 2/11/2026

Page 7

Time span=0.00-24.00 hrs, dt=0.05 hrs, 481 points
Runoff by SCS TR-20 method, UH=SCS, Weighted-CN
Reach routing by Stor-Ind+Trans method - Pond routing by Stor-Ind method

Subcatchment1: Grass

Runoff Area=11,895 sf 0.00% Impervious Runoff Depth>3.84"
Tc=5.0 min CN=61 Runoff=1.22 cfs 3,801 cf

Subcatchment2: Grass

Runoff Area=5,565 sf 0.00% Impervious Runoff Depth>3.84"
Tc=5.0 min CN=61 Runoff=0.57 cfs 1,778 cf

Reach SP1: Offsite Flow

Inflow=1.22 cfs 3,801 cf
Outflow=1.22 cfs 3,801 cf

Reach SP2: Offsite Flow

Inflow=0.57 cfs 1,778 cf
Outflow=0.57 cfs 1,778 cf

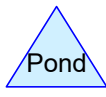
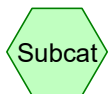
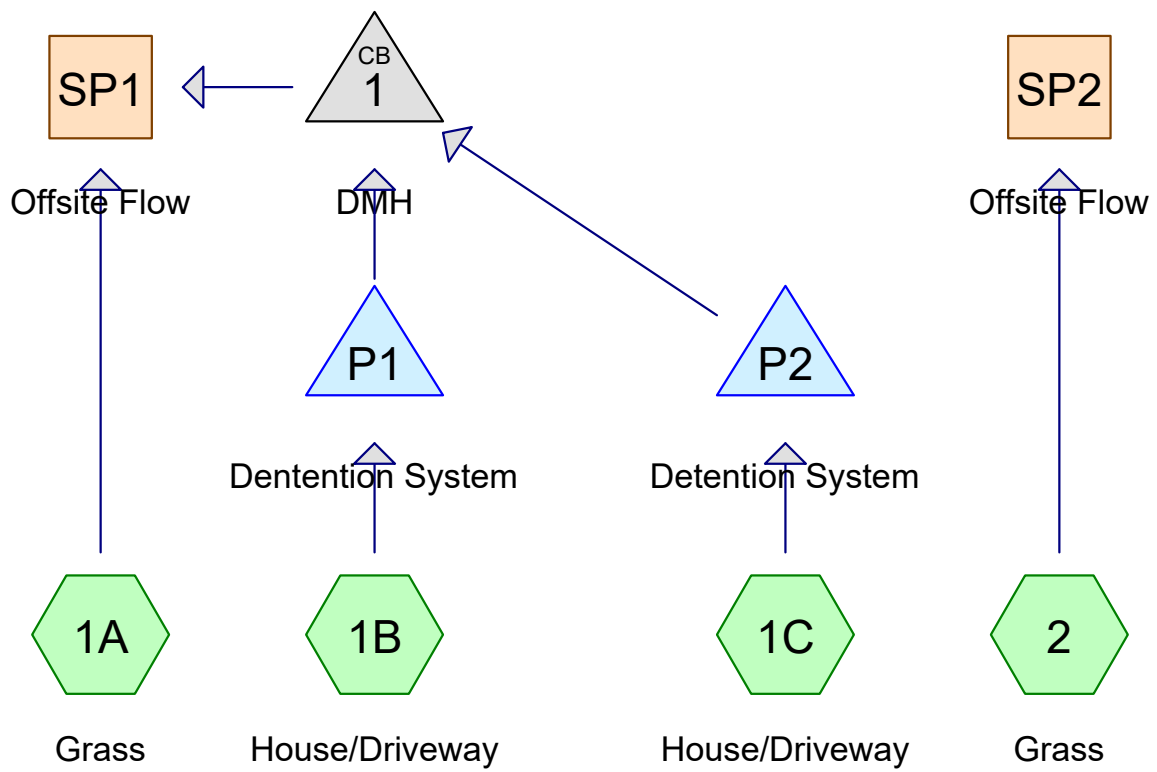

5010220.003-Post

Prepared by Haley Ward

HydroCAD® 10.20-7a s/n 00641 © 2025 HydroCAD Software Solutions LLC

Printed 2/11/2026

Page 2

Area Listing (all nodes)

Area (sq-ft)	CN	Description (subcatchment-numbers)
11,665	61	>75% Grass cover, Good, HSG B (1A, 1B, 1C, 2)
5,795	98	Paved parking, HSG B (1B, 1C, 2)

5010220.003-Post

Prepared by Haley Ward

HydroCAD® 10.20-7a s/n 00641 © 2025 HydroCAD Software Solutions LLC

Printed 2/11/2026

Page 3

Soil Listing (all nodes)

Area (sq-ft)	Soil Group	Subcatchment Numbers
0	HSG A	
17,460	HSG B	1A, 1B, 1C, 2
0	HSG C	
0	HSG D	
0	Other	

5010220.003-Post

Prepared by Haley Ward

HydroCAD® 10.20-7a s/n 00641 © 2025 HydroCAD Software Solutions LLC

Type III 24-hr 2-Yr Rainfall=3.70"

Printed 2/11/2026

Page 4

Time span=0.00-24.00 hrs, dt=0.05 hrs, 481 points
Runoff by SCS TR-20 method, UH=SCS, Weighted-CN
Reach routing by Stor-Ind+Trans method - Pond routing by Stor-Ind method

Subcatchment1A: Grass	Runoff Area=6,365 sf 0.00% Impervious Tc=5.0 min CN=61	Runoff Depth>0.66" Runoff=0.09 cfs 352 cf
Subcatchment1B: House/Driveway	Runoff Area=3,740 sf 74.33% Impervious Tc=5.0 min CN=89	Runoff Depth>2.54" Runoff=0.25 cfs 792 cf
Subcatchment1C: House/Driveway	Runoff Area=3,225 sf 82.64% Impervious Tc=5.0 min CN=92	Runoff Depth>2.83" Runoff=0.24 cfs 760 cf
Subcatchment2: Grass	Runoff Area=4,130 sf 8.47% Impervious Tc=5.0 min CN=64	Runoff Depth>0.81" Runoff=0.08 cfs 278 cf
Reach SP1: Offsite Flow		Inflow=0.16 cfs 975 cf Outflow=0.16 cfs 975 cf
Reach SP2: Offsite Flow		Inflow=0.08 cfs 278 cf Outflow=0.08 cfs 278 cf
Pond 1: DMH	12.0" Round Culvert n=0.013 L=105.0' S=0.0267 '/'	Peak Elev=19.24' Inflow=0.09 cfs 622 cf Outflow=0.09 cfs 622 cf
Pond P1: Dentention System		Peak Elev=24.13' Storage=251 cf Inflow=0.25 cfs 792 cf Discarded=0.02 cfs 465 cf Primary=0.05 cfs 326 cf Outflow=0.06 cfs 791 cf
Pond P2: Detention System		Peak Elev=24.05' Storage=237 cf Inflow=0.24 cfs 760 cf Discarded=0.02 cfs 463 cf Primary=0.04 cfs 296 cf Outflow=0.06 cfs 759 cf

5010220.003-Post

Prepared by Haley Ward

HydroCAD® 10.20-7a s/n 00641 © 2025 HydroCAD Software Solutions LLC

Type III 24-hr 10-Yr Rainfall=5.61"

Printed 2/11/2026

Page 5

Time span=0.00-24.00 hrs, dt=0.05 hrs, 481 points
Runoff by SCS TR-20 method, UH=SCS, Weighted-CN
Reach routing by Stor-Ind+Trans method - Pond routing by Stor-Ind method

Subcatchment1A: Grass	Runoff Area=6,365 sf 0.00% Impervious Runoff Depth>1.75" Tc=5.0 min CN=61 Runoff=0.28 cfs 927 cf
Subcatchment1B: House/Driveway	Runoff Area=3,740 sf 74.33% Impervious Runoff Depth>4.36" Tc=5.0 min CN=89 Runoff=0.43 cfs 1,358 cf
Subcatchment1C: House/Driveway	Runoff Area=3,225 sf 82.64% Impervious Runoff Depth>4.68" Tc=5.0 min CN=92 Runoff=0.39 cfs 1,259 cf
Subcatchment2: Grass	Runoff Area=4,130 sf 8.47% Impervious Runoff Depth>1.99" Tc=5.0 min CN=64 Runoff=0.21 cfs 684 cf
Reach SP1: Offsite Flow	Inflow=0.53 cfs 2,298 cf Outflow=0.53 cfs 2,298 cf
Reach SP2: Offsite Flow	Inflow=0.21 cfs 684 cf Outflow=0.21 cfs 684 cf
Pond 1: DMH	Peak Elev=19.39' Inflow=0.34 cfs 1,371 cf 12.0" Round Culvert n=0.013 L=105.0' S=0.0267 '/' Outflow=0.34 cfs 1,371 cf
Pond P1: Dentention System	Peak Elev=24.77' Storage=370 cf Inflow=0.43 cfs 1,358 cf Discarded=0.02 cfs 625 cf Primary=0.18 cfs 731 cf Outflow=0.20 cfs 1,356 cf
Pond P2: Detention System	Peak Elev=24.66' Storage=349 cf Inflow=0.39 cfs 1,259 cf Discarded=0.02 cfs 617 cf Primary=0.16 cfs 640 cf Outflow=0.18 cfs 1,258 cf

Summary for Subcatchment 1A: Grass

Runoff = 0.28 cfs @ 12.09 hrs, Volume= 927 cf, Depth> 1.75"
 Routed to Reach SP1 : Offsite Flow

Runoff by SCS TR-20 method, UH=SCS, Weighted-CN, Time Span= 0.00-24.00 hrs, dt= 0.05 hrs
 Type III 24-hr 10-Yr Rainfall=5.61"

Area (sf)	CN	Description
6,365	61	>75% Grass cover, Good, HSG B
6,365		100.00% Pervious Area

Tc (min)	Length (feet)	Slope (ft/ft)	Velocity (ft/sec)	Capacity (cfs)	Description
5.0					Direct Entry,

Summary for Subcatchment 1B: House/Driveway

Runoff = 0.43 cfs @ 12.07 hrs, Volume= 1,358 cf, Depth> 4.36"
 Routed to Pond P1 : Dentention System

Runoff by SCS TR-20 method, UH=SCS, Weighted-CN, Time Span= 0.00-24.00 hrs, dt= 0.05 hrs
 Type III 24-hr 10-Yr Rainfall=5.61"

Area (sf)	CN	Description
2,780	98	Paved parking, HSG B
960	61	>75% Grass cover, Good, HSG B
3,740	89	Weighted Average
960		25.67% Pervious Area
2,780		74.33% Impervious Area

Tc (min)	Length (feet)	Slope (ft/ft)	Velocity (ft/sec)	Capacity (cfs)	Description
5.0					Direct Entry,

Summary for Subcatchment 1C: House/Driveway

Runoff = 0.39 cfs @ 12.07 hrs, Volume= 1,259 cf, Depth> 4.68"
 Routed to Pond P2 : Detention System

Runoff by SCS TR-20 method, UH=SCS, Weighted-CN, Time Span= 0.00-24.00 hrs, dt= 0.05 hrs
 Type III 24-hr 10-Yr Rainfall=5.61"

Area (sf)	CN	Description
2,665	98	Paved parking, HSG B
560	61	>75% Grass cover, Good, HSG B
3,225	92	Weighted Average
560		17.36% Pervious Area
2,665		82.64% Impervious Area

5010220.003-Post

Prepared by Haley Ward

HydroCAD® 10.20-7a s/n 00641 © 2025 HydroCAD Software Solutions LLC

Type III 24-hr 10-Yr Rainfall=5.61"

Printed 2/11/2026

Page 7

Tc (min)	Length (feet)	Slope (ft/ft)	Velocity (ft/sec)	Capacity (cfs)	Description
5.0					Direct Entry,

Summary for Subcatchment 2: Grass

Runoff = 0.21 cfs @ 12.09 hrs, Volume= 684 cf, Depth> 1.99"
 Routed to Reach SP2 : Offsite Flow

Runoff by SCS TR-20 method, UH=SCS, Weighted-CN, Time Span= 0.00-24.00 hrs, dt= 0.05 hrs
 Type III 24-hr 10-Yr Rainfall=5.61"

Area (sf)	CN	Description
3,780	61	>75% Grass cover, Good, HSG B
350	98	Paved parking, HSG B
4,130	64	Weighted Average
3,780		91.53% Pervious Area
350		8.47% Impervious Area

Tc (min)	Length (feet)	Slope (ft/ft)	Velocity (ft/sec)	Capacity (cfs)	Description
5.0					Direct Entry,

Summary for Reach SP1: Offsite Flow

Inflow Area = 13,330 sf, 40.85% Impervious, Inflow Depth > 2.07" for 10-Yr event
 Inflow = 0.53 cfs @ 12.16 hrs, Volume= 2,298 cf
 Outflow = 0.53 cfs @ 12.16 hrs, Volume= 2,298 cf, Atten= 0%, Lag= 0.0 min

Routing by Stor-Ind+Trans method, Time Span= 0.00-24.00 hrs, dt= 0.05 hrs

Summary for Reach SP2: Offsite Flow

Inflow Area = 4,130 sf, 8.47% Impervious, Inflow Depth > 1.99" for 10-Yr event
 Inflow = 0.21 cfs @ 12.09 hrs, Volume= 684 cf
 Outflow = 0.21 cfs @ 12.09 hrs, Volume= 684 cf, Atten= 0%, Lag= 0.0 min

Routing by Stor-Ind+Trans method, Time Span= 0.00-24.00 hrs, dt= 0.05 hrs

Summary for Pond 1: DMH

Inflow Area = 6,965 sf, 78.18% Impervious, Inflow Depth = 2.36" for 10-Yr event
 Inflow = 0.34 cfs @ 12.24 hrs, Volume= 1,371 cf
 Outflow = 0.34 cfs @ 12.24 hrs, Volume= 1,371 cf, Atten= 0%, Lag= 0.0 min
 Primary = 0.34 cfs @ 12.24 hrs, Volume= 1,371 cf
 Routed to Reach SP1 : Offsite Flow

Routing by Stor-Ind method, Time Span= 0.00-24.00 hrs, dt= 0.05 hrs

5010220.003-Post

Prepared by Haley Ward

HydroCAD® 10.20-7a s/n 00641 © 2025 HydroCAD Software Solutions LLC

Type III 24-hr 10-Yr Rainfall=5.61"

Printed 2/11/2026

Page 8

Peak Elev= 19.39' @ 12.24 hrs

Device	Routing	Invert	Outlet Devices
#1	Primary	19.10'	12.0" Round Culvert L= 105.0' CPP, square edge headwall, Ke= 0.500 Inlet / Outlet Invert= 19.10' / 16.30' S= 0.0267 '/' Cc= 0.900 n= 0.013 Corrugated PE, smooth interior, Flow Area= 0.79 sf

Primary OutFlow Max=0.34 cfs @ 12.24 hrs HW=19.39' (Free Discharge)

←**1=Culvert** (Inlet Controls 0.34 cfs @ 1.82 fps)

Summary for Pond P1: Detention System

Inflow Area =	3,740 sf, 74.33% Impervious, Inflow Depth > 4.36" for 10-Yr event
Inflow =	0.43 cfs @ 12.07 hrs, Volume= 1,358 cf
Outflow =	0.20 cfs @ 12.24 hrs, Volume= 1,356 cf, Atten= 53%, Lag= 9.8 min
Discarded =	0.02 cfs @ 12.24 hrs, Volume= 625 cf
Primary =	0.18 cfs @ 12.24 hrs, Volume= 731 cf
Routed to Pond 1 : DMH	

Routing by Stor-Ind method, Time Span= 0.00-24.00 hrs, dt= 0.05 hrs

Peak Elev= 24.77' @ 12.24 hrs Surf.Area= 228 sf Storage= 370 cf

Plug-Flow detention time= 43.8 min calculated for 1,353 cf (100% of inflow)

Center-of-Mass det. time= 43.1 min (832.2 - 789.1)

Volume	Invert	Avail.Storage	Storage Description
#1A	22.50'	161 cf	9.87'W x 23.11'L x 3.82'H Field A 872 cf Overall - 469 cf Embedded = 403 cf x 40.0% Voids
#2A	23.00'	446 cf	Ferguson R-Tank HD 2 x 54 Inside #1 Inside= 15.7"W x 33.9"H => 3.52 sf x 2.35'L = 8.3 cf Outside= 15.7"W x 33.9"H => 3.70 sf x 2.35'L = 8.7 cf 54 Chambers in 6 Rows
		607 cf	Total Available Storage

Storage Group A created with Chamber Wizard

Device	Routing	Invert	Outlet Devices
#1	Primary	22.60'	12.0" Round Culvert L= 4.0' CPP, square edge headwall, Ke= 0.500 Inlet / Outlet Invert= 22.60' / 22.50' S= 0.0250 '/' Cc= 0.900 n= 0.013 Corrugated PE, smooth interior, Flow Area= 0.79 sf
#2	Device 1	23.00'	1.3" Vert. Orifice/Grate C= 0.600 Limited to weir flow at low heads
#3	Device 1	24.30'	2.8" Vert. Orifice/Grate C= 0.600 Limited to weir flow at low heads
#4	Device 1	25.70'	4.0' long Weir 2 End Contraction(s)
#5	Discarded	22.50'	2.000 in/hr Exfiltration over Wetted area

Discarded OutFlow Max=0.02 cfs @ 12.24 hrs HW=24.77' (Free Discharge)

↳5=Exfiltration (Exfiltration Controls 0.02 cfs)

Primary OutFlow Max=0.18 cfs @ 12.24 hrs HW=24.77' (Free Discharge)

↳1=Culvert (Passes 0.18 cfs of 4.89 cfs potential flow)

↳2=Orifice/Grate (Orifice Controls 0.06 cfs @ 6.31 fps)

↳3=Orifice/Grate (Orifice Controls 0.12 cfs @ 2.87 fps)

↳4=Weir (Controls 0.00 cfs)

Summary for Pond P2: Detention System

Inflow Area = 3,225 sf, 82.64% Impervious, Inflow Depth > 4.68" for 10-Yr event
 Inflow = 0.39 cfs @ 12.07 hrs, Volume= 1,259 cf
 Outflow = 0.18 cfs @ 12.24 hrs, Volume= 1,258 cf, Atten= 55%, Lag= 10.2 min
 Discarded = 0.02 cfs @ 12.24 hrs, Volume= 617 cf
 Primary = 0.16 cfs @ 12.24 hrs, Volume= 640 cf
 Routed to Pond 1 : DMH

Routing by Stor-Ind method, Time Span= 0.00-24.00 hrs, dt= 0.05 hrs
 Peak Elev= 24.66' @ 12.24 hrs Surf.Area= 228 sf Storage= 349 cf

Plug-Flow detention time= 43.8 min calculated for 1,258 cf (100% of inflow)
 Center-of-Mass det. time= 43.1 min (821.0 - 777.9)

Volume	Invert	Avail.Storage	Storage Description
#1A	22.50'	161 cf	9.87'W x 23.11'L x 3.82'H Field A 872 cf Overall - 469 cf Embedded = 403 cf x 40.0% Voids
#2A	23.00'	446 cf	Ferguson R-Tank HD 2 x 54 Inside #1 Inside= 15.7"W x 33.9"H => 3.52 sf x 2.35'L = 8.3 cf Outside= 15.7"W x 33.9"H => 3.70 sf x 2.35'L = 8.7 cf 54 Chambers in 6 Rows
		607 cf	Total Available Storage

Storage Group A created with Chamber Wizard

Device	Routing	Invert	Outlet Devices
#1	Primary	19.30'	12.0" Round Culvert L= 20.0' CPP, square edge headwall, Ke= 0.500 Inlet / Outlet Invert= 19.30' / 19.20' S= 0.0050 ' / Cc= 0.900 n= 0.013 Corrugated PE, smooth interior, Flow Area= 0.79 sf
#2	Device 1	23.00'	1.3" Vert. Orifice/Grate C= 0.600 Limited to weir flow at low heads
#3	Device 1	24.30'	2.8" Vert. Orifice/Grate C= 0.600 Limited to weir flow at low heads
#4	Device 1	25.70'	4.0' long Weir 2 End Contraction(s)
#5	Discarded	22.50'	2.000 in/hr Exfiltration over Wetted area

5010220.003-Post

Prepared by Haley Ward

HydroCAD® 10.20-7a s/n 00641 © 2025 HydroCAD Software Solutions LLC

Type III 24-hr 10-Yr Rainfall=5.61"

Printed 2/11/2026

Page 10

Discarded OutFlow Max=0.02 cfs @ 12.24 hrs HW=24.66' (Free Discharge)

↑5=Exfiltration (Exfiltration Controls 0.02 cfs)

Primary OutFlow Max=0.16 cfs @ 12.24 hrs HW=24.66' (Free Discharge)

↑1=Culvert (Passes 0.16 cfs of 8.34 cfs potential flow)

↑2=Orifice/Grate (Orifice Controls 0.06 cfs @ 6.10 fps)

↑3=Orifice/Grate (Orifice Controls 0.10 cfs @ 2.37 fps)

↑4=Weir (Controls 0.00 cfs)

5010220.003-Post

Prepared by Haley Ward

HydroCAD® 10.20-7a s/n 00641 © 2025 HydroCAD Software Solutions LLC

Type III 24-hr 50-Yr Rainfall=8.51"

Printed 2/11/2026

Page 11

Time span=0.00-24.00 hrs, dt=0.05 hrs, 481 points
Runoff by SCS TR-20 method, UH=SCS, Weighted-CN
Reach routing by Stor-Ind+Trans method - Pond routing by Stor-Ind method

Subcatchment1A: Grass	Runoff Area=6,365 sf 0.00% Impervious Runoff Depth>3.84" Tc=5.0 min CN=61 Runoff=0.65 cfs 2,034 cf
Subcatchment1B: House/Driveway	Runoff Area=3,740 sf 74.33% Impervious Runoff Depth>7.18" Tc=5.0 min CN=89 Runoff=0.68 cfs 2,239 cf
Subcatchment1C: House/Driveway	Runoff Area=3,225 sf 82.64% Impervious Runoff Depth>7.54" Tc=5.0 min CN=92 Runoff=0.60 cfs 2,028 cf
Subcatchment2: Grass	Runoff Area=4,130 sf 8.47% Impervious Runoff Depth>4.19" Tc=5.0 min CN=64 Runoff=0.47 cfs 1,442 cf
Reach SP1: Offsite Flow	Inflow=1.17 cfs 4,706 cf Outflow=1.17 cfs 4,706 cf
Reach SP2: Offsite Flow	Inflow=0.47 cfs 1,442 cf Outflow=0.47 cfs 1,442 cf
Pond 1: DMH	Peak Elev=19.51' Inflow=0.67 cfs 2,672 cf 12.0" Round Culvert n=0.013 L=105.0' S=0.0267 '/ Outflow=0.67 cfs 2,672 cf
Pond P1: Dentention System	Peak Elev=25.73' Storage=545 cf Inflow=0.68 cfs 2,239 cf Discarded=0.02 cfs 803 cf Primary=0.39 cfs 1,434 cf Outflow=0.41 cfs 2,237 cf
Pond P2: Detention System	Peak Elev=25.49' Storage=501 cf Inflow=0.60 cfs 2,028 cf Discarded=0.02 cfs 789 cf Primary=0.28 cfs 1,237 cf Outflow=0.30 cfs 2,026 cf

Soil Map—Rockingham County, New Hampshire



Soil Map may not be valid at this scale.

Map Scale: 1:526 if printed on A portrait (8.5" x 11") sheet.

0 5 10 20 30 Meters

0 25 50 100 150 Feet

Map projection: Web Mercator Corner coordinates: WGS84 Edge tics: UTM Zone 19N WGS84





MAP LEGEND

Area of Interest (AOI)

 Area of Interest (AOI)

Soils

 Soil Map Unit Polygons

 Soil Map Unit Lines

 Soil Map Unit Points

Special Point Features



Blowout



Borrow Pit



Clay Spot



Closed Depression



Gravel Pit



Gravelly Spot



Landfill



Lava Flow



Marsh or swamp



Mine or Quarry



Miscellaneous Water



Perennial Water



Rock Outcrop



Saline Spot



Sandy Spot



Severely Eroded Spot



Sinkhole



Slide or Slip



Sodic Spot



Spoil Area



Stony Spot



Very Stony Spot



Wet Spot



Other



Special Line Features

Water Features



Streams and Canals

Transportation



Rails



Interstate Highways



US Routes



Major Roads



Local Roads

Background



Aerial Photography

MAP INFORMATION

The soil surveys that comprise your AOI were mapped at 1:24,000.

Warning: Soil Map may not be valid at this scale.

Enlargement of maps beyond the scale of mapping can cause misunderstanding of the detail of mapping and accuracy of soil line placement. The maps do not show the small areas of contrasting soils that could have been shown at a more detailed scale.

Please rely on the bar scale on each map sheet for map measurements.

Source of Map: Natural Resources Conservation Service

Web Soil Survey URL:

Coordinate System: Web Mercator (EPSG:3857)

Maps from the Web Soil Survey are based on the Web Mercator projection, which preserves direction and shape but distorts distance and area. A projection that preserves area, such as the Albers equal-area conic projection, should be used if more accurate calculations of distance or area are required.

This product is generated from the USDA-NRCS certified data as of the version date(s) listed below.

Soil Survey Area: Rockingham County, New Hampshire

Survey Area Data: Version 28, Sep 9, 2025

Soil map units are labeled (as space allows) for map scales 1:50,000 or larger.

Date(s) aerial images were photographed: Jun 19, 2020—Sep 20, 2020

The orthophoto or other base map on which the soil lines were compiled and digitized probably differs from the background imagery displayed on these maps. As a result, some minor shifting of map unit boundaries may be evident.

Map Unit Legend

Map Unit Symbol	Map Unit Name	Acres in AOI	Percent of AOI
799	Urban land-Canton complex, 3 to 15 percent slopes	0.5	100.0%
Totals for Area of Interest		0.5	100.0%

CHINBURG DEVELOPMENT PROPOSED 2 LOT SUBDIVISION

RICHARDS AVENUE & SOUTH STREET, PORTSMOUTH, NH

PROJECT INFORMATION

CIVIL ENGINEER
HALEY WARD, INC.
ATTN: SHAWN TOBEY, PE.
200 GRIFFIN ROAD, UNIT 14
PORTSMOUTH, NH 03801
T: 603.430.9282

OWNER
J. PAUL GRIFFIN FAMILY TRUST
(AKA THE GRIFFIN FAMILY TRUST)
PETER J. GRIFFIN, TRUSTEE
P.O. BOX 149
PORTSMOUTH, NH 03801

SURVEYOR
HALEY WARD, INC.
ATTN: PHILLIP YETMAN, PLS
200 GRIFFIN ROAD, UNIT 14
PORTSMOUTH, NH 03801
T: 603.430.9282

APPLICANT
CHINBURG DEVELOPMENT
3 PENSTOCK WAY
NEWMARKET, NH 03857

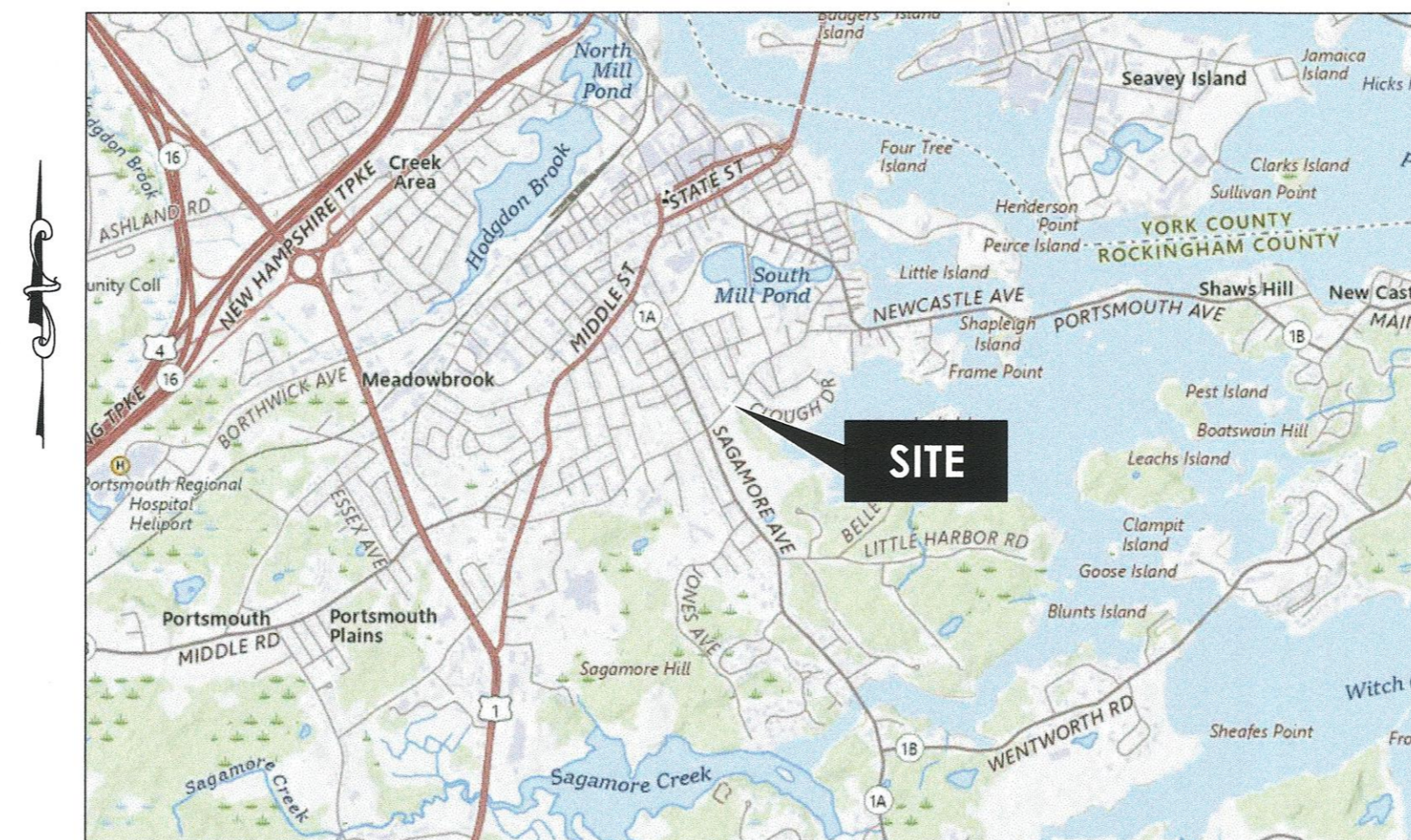

LOCATION MAP

INDEX OF DRAWINGS

- C000 COVER SHEET
- C001 GENERAL NOTES, LEGEND & ABBREVIATIONS
- V101 EXISTING CONDITIONS PLAN
SUBDIVISION PLAN
- C101 SITE LAYOUT PLAN
- C102 GRADING, DRAINAGE, & UTILITY PLAN
- C501 CONSTRUCTION DETAILS
- C502 CONSTRUCTION DETAILS
- C701 PRE-DEVELOPMENT HYDROLOGY PLAN
- C702 POST-DEVELOPMENT HYDROLOGY PLAN

UTILITY PROVIDERS

WATER & SEWER
CITY OF PORTSMOUTH DEPT. OF
PUBLIC WORKS
ATTN: DOUG SPARKS
680 PEVERLY HILL ROAD
PORTSMOUTH, NH 03801
T: 603.427.1530

ELECTRIC
EVERSOURCE
ATTN: NICHOLAS KOSKO
1700 LAFAYETTE ROAD
PORTSMOUTH, NH 03801
T: 603.436.7708, EXT. 3327565

CABLE
XFINITY BY COMCAST
ATTN: MIKE COLLINS
180 GREENLEAF AVENUE
PORTSMOUTH, NEW HAMPSHIRE 03801
T: 603.266.2278

COMMUNICATIONS
CONSOLIDATED COMMUNICATIONS
ATTN: BENJAMIN WILLS
1575 GREENLAND ROAD
GREENLAND, NEW HAMPSHIRE 03840
T: 603.427.5525

NATURAL GAS
UNITIL
ATTN: DAVE BEAULIEU
325 WEST ROAD
PORTSMOUTH, NEW HAMPSHIRE 03801
T: 603.294.5144

PERMITS & APPROVALS

PERMITS & APPROVALS	PERMIT #	DATE
CITY OF PORTSMOUTH TAC WORKSHOP	LUTW-26-02	COMPLETED 01/13/26
CITY OF PORTSMOUTH TAC REVIEW	LU-26-19	COMPLETED 03/03/26
CITY OF PORTSMOUTH PLANNING BOARD	LU-26-19	PENDING

**ISSUED FOR PERMITTING
MARCH 25, 2026**



HALEY WARD

www.haleyward.com

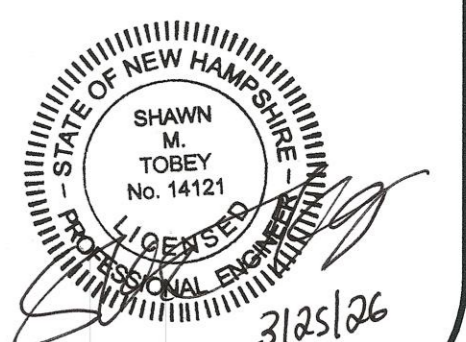

CONSTRUCTION SEQUENCE

- 1. DO NOT BEGIN CONSTRUCTION UNTIL ALL LOCAL, STATE AND FEDERAL PERMITS HAVE BEEN APPLIED FOR AND RECEIVED.
2. INSTALL SILT SOXX TO CONTROL EROSION AND SEDIMENTATION PRIOR TO ANY EARTH MOVING ACTIVITIES.
3. REMOVE EXISTING SITE FEATURES TO BE REMOVED.
4. CONSTRUCT STABILIZED CONSTRUCTION ENTRANCE.
5. CUT AND REMOVE ALL TREES, SHRUBS, AND OTHER DEBRIS AS REQUIRED.
6. STRIP AND STOCKPILE LOAM FROM SITE. STOCKPILES SHALL BE SURROUNDED WITH SILT SOXX TO CONTROL SEDIMENT RUN OFF.
7. ROUGH GRADE SITE AND CONSTRUCT DRAINAGE STRUCTURES, AND UNDERGROUND STORMWATER DETENTION. INSTALL AND MAINTAIN EROSION CONTROL DEVICES AS SHOWN ON THE PLANS. ALL PERMANENT DITCHES, AND SWALES SHALL BE STABILIZED PRIOR TO DIRECTING RUNOFF TO THEM. CONSTRUCT BUILDING FOUNDATIONS.
8. LOAM AND SEED DISTURBED AREAS. CUT AND FILL SLOPES SHALL BE SEEDED IMMEDIATELY AFTER THEIR CONSTRUCTION.
9. CONSTRUCT UTILITIES, BUILDINGS AND PAVEMENT BASE COURSE.
10. PLANT LANDSCAPING.
11. CONSTRUCT PAVEMENT WEARING COURSE.
12. REMOVE TRAPPED SEDIMENTS FROM COLLECTION DEVICES AS APPROPRIATE, AND THEN REMOVE TEMPORARY EROSION CONTROL MEASURES.

PROJECT DESCRIPTION

- 1. THE PROJECT CONSISTS OF SUBDIVIDING THE EXISTING LOT INTO TWO LOTS AND CONSTRUCTING TWO SINGLE FAMILY HOMES WITH ASSOCIATED SITE IMPROVEMENTS.
2. THE TOTAL AREA TO BE DISTURBED IS APPROXIMATELY 15,500 SQUARE FEET.
3. BASED ON THE USCS WEB SOIL SURVEY THE SOILS ON SITE CONSIST OF URBAN LAND - CANTON COMPLEX SOILS WITH AN ASSUMED HYDROLOGIC SOIL GROUP RATING OF C.
4. THE STORMWATER RUNOFF FROM THE SITE WILL FOLLOW EXISTING PATTERNS AND DISCHARGE OFFSITE TO THE ADJUTING PARCEL AND INTO THE CITY STORMWATER SYSTEM IN RICHARDS AVENUE.

GENERAL CONSTRUCTION NOTES

- 1. THE EROSION CONTROL PROCEDURES SHALL CONFORM TO SECTION 646 OF THE "STANDARD SPECIFICATION FOR ROAD AND BRIDGE CONSTRUCTION" OF THE NHDOT, AND "STORM WATER MANAGEMENT AND EROSION AND SEDIMENT CONTROL HANDBOOK FOR URBAN AND DEVELOPING AREAS IN NEW HAMPSHIRE". THE PROJECT IS TO BE MANAGED IN A MANNER THAT MEETS THE REQUIREMENTS AND INTENT OF RSA 430:53 AND CHAPTER AGR 3800 RELATIVE TO INVASIVE SPECIES.
2. DURING CONSTRUCTION AND THEREAFTER, EROSION CONTROL MEASURES ARE TO BE IMPLEMENTED AS NOTED. THE SMALLEST PRACTICAL AREA OF LAND SHOULD BE EXPOSED AT ANY ONE TIME DURING DEVELOPMENT. NO DISTURBED AREA SHALL BE LEFT UNSTABILIZED FOR MORE THAN 45 DAYS.
3. ANY DISTURBED AREAS WHICH ARE TO BE LEFT TEMPORARILY, AND WHICH WILL BE REGRADED LATER DURING CONSTRUCTION SHALL BE MACHINE HAY MULCHED AND SEEDED WITH RYE GRASS TO PREVENT EROSION.
4. THE PROJECT IS TO BE MANAGED IN A MANNER THAT MEETS THE REQUIREMENTS AND INTENT OF RSA 430:53 AND CHAPTER AGR 3800 RELATIVE TO INVASIVE SPECIES.
5. DUST CONTROL MEASURES SHALL INCLUDE BUT ARE NOT LIMITED TO SPRINKLING WATER ON EXPOSED AREAS, COVERING LOADED DUMP TRUCKS LEAVING THE SITE, AND TEMPORARY MULCHING. DUST CONTROL MEASURES SHALL BE UTILIZED SO AS TO PREVENT THE MIGRATION OF DUST FROM THE SITE TO ADJUTING AREAS. IF TEMPORARY STABILIZATION PRACTICES, SUCH AS TEMPORARY VEGETATION AND MULCHING, DO NOT ADEQUATELY REDUCE DUST GENERATION, APPLICATION OF WATER OR CALCIUM CHLORIDE SHALL BE APPLIED IN ACCORDANCE WITH BEST MANAGEMENT PRACTICES.
6. SILT/SOXX SHALL BE PERIODICALLY INSPECTED DURING THE LIFE OF THE PROJECT AND AFTER EACH STORM. ALL DAMAGED SILT/SOXX SHALL BE REPAIRED. SEDIMENT DEPOSITS SHALL PERIODICALLY BE REMOVED AND DISPOSED IN A SECURED LOCATION.
7. ALL FILLS SHALL BE PLACED AND COMPACTED TO REDUCE EROSION, SLIPPAGE, SETTLEMENT, SUBSIDENCE OR OTHER RELATED PROBLEMS.
8. ALL NON-STRUCTURAL, SITE-FILL SHALL BE PLACED AND COMPACTED TO 90% MODIFIED PROCTOR DENSITY IN LAYERS NOT EXCEEDING 18 INCHES IN THICKNESS UNLESS OTHERWISE NOTED.
9. FROZEN MATERIAL OR SOFT, MUCKY OR HIGHLY COMPRESSIBLE MATERIAL, TRASH, WOODY DEBRIS, LEAVES, BRUSH OR ANY DELETERIOUS MATTER SHALL NOT BE INCORPORATED INTO FILLS.
10. FILL MATERIAL SHALL NOT BE PLACED ON FROZEN FOUNDATION SUBGRADE.
11. DURING CONSTRUCTION AND UNTIL ALL DEVELOPED AREAS ARE FULLY STABILIZED, ALL EROSION CONTROL MEASURES SHALL BE INSPECTED WEEKLY AND AFTER EACH ONE HALF INCH OF RAINFALL.
12. THE CONTRACTOR SHALL MODIFY OR ADD EROSION CONTROL MEASURES AS NECESSARY TO ACCOMMODATE PROJECT CONSTRUCTION.
13. ALL ROADWAYS AND PARKING AREAS SHALL BE STABILIZED WITHIN 72 HOURS OF ACHIEVING FINISHED GRADE. ALL CUT AND FILL SLOPES SHALL BE SEEDED/LOADED WITHIN 72 HOURS OF ACHIEVING FINISHED GRADE.
14. AN AREA SHALL BE CONSIDERED STABLE IF ONE OF THE FOLLOWING HAS OCCURRED:
- BASE COURSE GRAVELS HAVE BEEN INSTALLED ON AREAS TO BE PAVED
- A MINIMUM OF 85% VEGETATED GROWTH HAS BEEN ESTABLISHED
- A MINIMUM OF 3 INCHES OF NON-EROSIVE MATERIAL SUCH AS STONE OR RIPRAP HAS BEEN INSTALLED
- EROSION CONTROL BLANKETS HAVE BEEN INSTALLED
- IN AREAS TO BE PAVED, "STABLE" MEANS THAT BASE COURSE GRAVELS MEETING THE REQUIREMENTS OF NHDOT STANDARD FOR ROAD AND BRIDGE CONSTRUCTION, 2016, ITEM 304.2 HAVE BEEN INSTALLED.
15. STABILIZATION SHALL BE INITIATED ON ALL LOAM STOCKPILES, AND DISTURBED AREAS, WHERE CONSTRUCTION ACTIVITY SHALL NOT OCCUR FOR MORE THAN TWENTY-ONE (21) CALENDAR DAYS BY THE FOURTEENTH (14TH) DAY AFTER CONSTRUCTION ACTIVITY HAS PERMANENTLY OR TEMPORARILY CEASED IN THAT AREA.
16. STABILIZATION MEASURES TO BE USED INCLUDE:
- TEMPORARY SEEDING;
- MULCHING.
17. ALL AREAS SHALL BE STABILIZED WITHIN 45 DAYS OF INITIAL DISTURBANCE.
18. WHEN CONSTRUCTION ACTIVITY PERMANENTLY OR TEMPORARILY CEASES WITHIN 100 FEET OF NEARBY SURFACE WATERS OR DELINEATED WETLANDS, THE AREA SHALL BE STABILIZED WITHIN SEVEN (7) DAYS OR PRIOR TO A RAIN EVENT. ONCE CONSTRUCTION ACTIVITY CEASES PERMANENTLY IN THESE AREAS, SILT/SOXX, MULCH BERMS, HAY BALE BARRIERS AND ANY EARTHDIKES SHALL BE REMOVED ONCE PERMANENT MEASURES ARE ESTABLISHED.
19. DURING CONSTRUCTION, RUNOFF WILL BE DIVERTED AROUND THE SITE WITH EARTH DIKES, PIPING OR STABILIZED CHANNELS WHERE POSSIBLE. SHEET RUNOFF FROM THE SITE WILL BE FILTERED THROUGH SILT/SOXX, MULCH BERMS, HAY BALE BARRIERS, OR SILT SOCKS. ALL STORM DRAIN BASIN INLETS SHALL BE PROVIDED WITH FLARED END SECTIONS AND TRASH RACKS. THE SITE SHALL BE STABILIZED FOR THE WINTER BY OCTOBER 15.

MAINTENANCE AND PROTECTION

- 1. THE SILT/SOXX BARRIER SHALL BE CHECKED AFTER EACH RAINFALL AND AT LEAST DAILY DURING PROLONGED RAINFALL.
2. SILT/SOXX SHALL BE REMOVED ONCE SITE IS STABILIZED, AND DISTURBED AREAS RESULTING FROM SILT/SOXX REMOVAL SHALL BE PERMANENTLY SEEDED.
3. THE CATCH BASIN INLET BASKET SHALL BE INSPECTED WITHIN 24 HOURS AFTER EACH RAINFALL OR DAILY DURING EXTENDED PERIODS OF PRECIPITATION. REPAIRS SHALL BE MADE IMMEDIATELY, AS NECESSARY, TO PREVENT PARTICLES FROM REACHING THE DRAINAGE SYSTEM AND/OR CAUSING SURFACE FLOODING. SEDIMENT DEPOSITS SHALL BE REMOVED AFTER EACH STORM EVENT, OR MORE OFTEN IF THE FABRIC BECOMES CLOGGED.

WINTER NOTES

- 1. ALL PROPOSED VEGETATED AREAS THAT DO NOT EXHIBIT A MINIMUM OF 85% VEGETATED GROWTH BY OCTOBER 15, OR WHICH ARE DISTURBED AFTER OCTOBER 15, SHALL BE STABILIZED TEMPORARILY WITH STONE OR EROSION CONTROL BLANKETS ON SLOPES GREATER THAN 3:1, AND SEEDING AND PLACING 3 TO 4 TONS OF MULCH PER ACRE, SECURED WITH ANCHORED NETTING, ELSEWHERE. THE INSTALLATION OF EROSION CONTROL BLANKETS OR MULCH AND NETTING SHALL NOT OCCUR OVER ACCUMULATED SNOW OR ON FROZEN GROUND AND SHALL BE COMPLETED IN ADVANCE OF THAW OR SPRING MELT EVENTS.
2. ALL DITCHES OR SWALES WHICH DO NOT EXHIBIT A MINIMUM OF 85 PERCENT VEGETATIVE GROWTH BY OCTOBER 15, OR WHICH ARE DISTURBED AFTER OCTOBER 15, SHALL BE STABILIZED TEMPORARILY WITH STONE OR EROSION CONTROL BLANKETS APPROPRIATE FOR THE DESIGN FLOW CONDITIONS;
3. AFTER OCTOBER 15, INCOMPLETE ROAD OR PARKING SURFACES, WHERE WORK HAS STOPPED FOR THE WINTER SEASON, SHALL BE PROTECTED WITH A MINIMUM OF 3 INCHES OF CRUSHED GRAVEL PER NHDOT ITEM 304.3, OR IF CONSTRUCTION IS TO CONTINUE THROUGH THE WINTER SEASON BE CLEARED OF ANY ACCUMULATED SNOW AFTER EACH STORM EVENT;

STOCKPILES

- 1. LOCATE STOCKPILES A MINIMUM OF 50 FEET AWAY FROM CATCH BASINS, SWALES, AND CULVERTS.
2. ALL STOCKPILES SHOULD BE SURROUNDED WITH TEMPORARY EROSION CONTROL MEASURES PRIOR TO THE ONSET OF PRECIPITATION.
3. PERIMETER BARRIERS SHOULD BE MAINTAINED AT ALL TIMES, AND ADJUSTED AS NEEDED TO ACCOMMODATE THE DELIVERY AND REMOVAL OF MATERIALS FROM THE STOCKPILE. THE INTEGRITY OF THE BARRIER SHOULD BE INSPECTED AT THE END OF EACH WORKING DAY.
4. PROTECT ALL STOCKPILES FROM STORMWATER RUN-OFF USING TEMPORARY EROSION CONTROL MEASURES SUCH AS BERMS, SILT SOCKS, OR OTHER APPROVED PRACTICE TO PREVENT MIGRATION OF MATERIAL BEYOND THE IMMEDIATE CONFINES OF THE STOCKPILES.

CONCRETE WASHOUT AREA

THE FOLLOWING ARE THE ONLY NON-STORMWATER DISCHARGES ALLOWED. ALL OTHER NON-STORMWATER DISCHARGES ARE PROHIBITED ON SITE:

- 1. THE CONCRETE DELIVERY TRUCKS SHALL, WHENEVER POSSIBLE, USE WASHOUT FACILITIES AT THEIR OWN PLANT OR DISPATCH FACILITY;
2. IF IT IS NECESSARY, SITE CONTRACTOR SHALL DESIGNATE SPECIFIC WASHOUT AREAS AND DESIGN FACILITIES TO HANDLE ANTICIPATED WASHOUT WATER;
3. CONTRACTOR SHALL LOCATE WASHOUT AREAS AT LEAST 150 FEET AWAY FROM STORM DRAINS, SWALES AND SURFACE WATERS OR DELINEATED WETLANDS;
4. INSPECT WASHOUT FACILITIES DAILY TO DETECT LEAKS OR TEARS AND TO IDENTIFY WHEN MATERIALS NEED TO BE REMOVED.

UTILITY NOTES

- 1. SEE EXISTING CONDITIONS PLAN FOR BENCHMARK INFORMATION.
2. COORDINATE ALL UTILITY WORK WITH APPROPRIATE UTILITY.
3. SEE GRADING AND DRAINAGE PLAN FOR PROPOSED GRADING AND EROSION CONTROL MEASURES.
4. ALL SEWER PIPE SHALL BE PVC SDR 35 UNLESS OTHERWISE STATED.
5. ALL WORK WITHIN CITY R.O.W. SHALL BE COORDINATED WITH CITY OF PORTSMOUTH

- 6. CONTRACTOR SHALL MAINTAIN UTILITY SERVICES TO ADJUTING PROPERTIES THROUGHOUT CONSTRUCTION.
7. EXISTING UTILITIES TO BE REMOVED SHALL BE CAPPED AT THE MAIN AND MEET THE DEPARTMENT OF PUBLIC WORKS STANDARDS FOR CAPPING OF WATER AND SEWER SERVICES.
8. ALL ELECTRICAL MATERIAL WORKMANSHIP SHALL CONFORM TO THE NATIONAL ELECTRIC CODE, LATEST EDITION, AND ALL APPLICABLE STATE AND LOCAL CODES.
9. THE EXACT LOCATION OF NEW UTILITY SERVICES AND CONNECTIONS SHALL BE COORDINATED WITH BUILDING DRAWINGS AND UTILITY COMPANIES.
10. ADJUST ALL MANHOLES, CATCH BASINS, CURB BOXES, ETC. WITHIN LIMITS OF WORK TO FINISH GRADE.
11. ALL UNDERGROUND CONDUITS SHALL HAVE NYLON PULL ROPES TO FACILITATE PULLING CABLES.
12. THE CONTRACTOR SHALL OBTAIN, PAY FOR, AND COMPLY WITH ALL REQUIRED PERMITS, ARRANGE FOR ALL INSPECTIONS, AND SUBMIT COPIES OF ACCEPTANCE CERTIFICATED TO THE OWNER PRIOR TO THE COMPLETION OF PROJECT.
13. THE CONTRACTOR SHALL PROVIDE AND INSTALL ALL MANHOLES, BOXES, FITTINGS, CONNECTORS, COVER PLATES AND OTHER MISCELLANEOUS ITEMS NOT NECESSARILY DETAILED IN THESE DRAWING TO RENDER INSTALLATION OF UTILITIES COMPLETE AND OPERATIONAL.
14. CONTRACTOR SHALL PROVIDE EXCAVATION, BEDDING, BACKFILL AND COMPACTION FOR NATURAL GAS SERVICES.
15. A 10-FOOT MINIMUM EDGE TO EDGE HORIZONTAL SEPARATION SHALL BE PROVIDED BETWEEN ALL WATER AND SANITARY SEWER LINES. AN 18-INCH MINIMUM OUTSIDE TO OUTSIDE VERTICAL SEPARATION SHALL BE PROVIDED AT ALL WATER/SANITARY SEWER CROSSINGS WATER ABOVE SEWER.
16. SAWCUT AND REMOVE PAVEMENT AND CONSTRUCT PAVEMENT TRENCH PATCH FOR ALL PROPOSED UTILITIES LOCATED IN EXISTING PAVED AREAS.
17. GATE VALVES, FITTINGS, ETC. SHALL MEET THE REQUIREMENTS OF THE CITY OF PORTSMOUTH.
18. COORDINATE TESTING OF SEWER CONSTRUCTION WITH THE CITY OF PORTSMOUTH.
19. ALL SEWER PIPES WITH LESS THAN 6" COVER SHALL BE INSULATED.
20. CONTRACTOR SHALL COORDINATE ALL ELECTRIC WORK INCLUDING BUT NOT LIMITED TO: CONDUIT CONSTRUCTION, MANHOLE CONSTRUCTION, UTILITY POLE CONSTRUCTION, OVERHEAD WIRE RELOCATION, AND TRANSFORMER CONSTRUCTION WITH POWER COMPANY.
21. SITE LIGHTING SPECIFICATIONS, CONDUIT LAYOUT AND CIRCUITRY FOR PROPOSED SITE LIGHTING AND SIGN ILLUMINATION SHALL BE PROVIDED BY THE PROJECT ELECTRICAL ENGINEER IN COORDINATION WITH THE SITE CIVIL ENGINEER.
22. CONTRACTOR SHALL CONSTRUCT ALL UTILITIES AND DRAINS TO WITHIN 10' OF THE FOUNDATION WALLS AND CONNECT THESE TO SERVICE STUBS FROM THE BUILDING.
23. FINAL REVIEW OF ALL UTILITIES SHALL BE MADE DURING THE REQUIRED SEWER CONNECTION PERMIT PROCESS IN COORDINATION WITH DEPARTMENT OF PUBLIC WORKS.
24. ALL WORK PERFORMED IN THE PUBLIC RIGHT-OF-WAY SHALL BE BUILT TO DEPARTMENT OF PUBLIC WORKS STANDARDS.
25. THE CONTRACTOR SHALL NOTIFY DIG SAFE AT 1-888-DIG-SAFE (1-888-344-7233) AT LEAST 72 HOURS PRIOR TO COMMENCING ANY EXCAVATION ON PUBLIC OR PRIVATE PROPERTY WITHIN 100 FEET OF UNDERGROUND UTILITIES. THE EXCAVATOR IS RESPONSIBLE TO MAINTAIN MARKS. DIG SAFE TICKETS EXPIRE IN THIRTY DAYS.
26. UNDERGROUND UTILITY LOCATIONS ARE BASED UPON BEST AVAILABLE EVIDENCE AND ARE NOT FIELD VERIFIED. LOCATING AND PROTECTING ANY ABOVEGROUND OR UNDERGROUND UTILITIES IS THE SOLE RESPONSIBILITY OF THE CONTRACTOR AND/OR THE OWNER. UTILITY CONFLICTS SHOULD BE REPORTED AT ONCE TO THE DESIGN ENGINEER.
27. IRRIGATION, IF SUPPLIED, WILL BE PROVIDED ON A SEPARATE METERED SERVICE. DESIGNS OF IRRIGATION WILL BE PROVIDED BY THE LANDSCAPE CONTRACTOR AT THE TIME OF CONSTRUCTION.

ALLOWABLE NON-STORMWATER DISCHARGES

- 1. FIRE-FIGHTING ACTIVITIES;
2. FIRE HYDRANT FLUSHING;
3. WATERS USED TO WASH VEHICLES WHERE DETERGENTS ARE NOT USED;
4. WATER USED TO CONTROL DUST;
5. POTABLE WATER INCLUDING UNCONTAMINATED WATER LINE FLUSHING;
6. ROUTINE EXTERNAL BUILDING WASH DOWN WHERE DETERGENTS ARE NOT USED;
7. PAVEMENT WASH WATERS WHERE DETERGENTS ARE NOT USED;
8. UNCONTAMINATED AIR CONDITIONING/COMPRESSOR CONDENSATION;
9. UNCONTAMINATED GROUND WATER OR SPRING WATER;
10. FOUNDATION OR FOOTING DRAINS WHICH ARE UNCONTAMINATED;
11. UNCONTAMINATED EXCAVATION DEWATERING;
12. LANDSCAPE IRRIGATION.

WASTE DISPOSAL

- 1. WASTE MATERIAL
- ALL WASTE MATERIALS SHALL BE COLLECTED AND STORED IN SECURELY LIDDED RECEPTACLES. ALL TRASH AND CONSTRUCTION DEBRIS FROM THE SITE SHALL BE DEPOSITED IN A DUMPSTER;
- NO CONSTRUCTION WASTE MATERIALS SHALL BE BURIED ON SITE;
- ALL PERSONNEL SHALL BE INSTRUCTED REGARDING THE CORRECT PROCEDURE FOR WASTE DISPOSAL BY THE SUPERINTENDENT.
2. HAZARDOUS WASTE
- ALL HAZARDOUS WASTE MATERIALS SHALL BE DISPOSED OF IN THE MANNER SPECIFIED BY LOCAL OR STATE REGULATION OR BY THE MANUFACTURER;
- SITE PERSONNEL SHALL BE INSTRUCTED IN THESE PRACTICES BY THE SUPERINTENDENT.
3. SANITARY WASTE
- ALL SANITARY WASTE SHALL BE COLLECTED FROM THE PORTABLE UNITS A MINIMUM OF ONCE PER WEEK BY A LICENSED SANITARY WASTE MANAGEMENT CONTRACTOR.

BLASTING NOTES

- 1. CONTRACTOR SHALL CONTACT THE NHDES AND/OR LOCAL JURISDICTION PRIOR TO COMMENCING ANY BLASTING ACTIVITIES.
2. FOR ANY PROJECT FOR WHICH BLASTING OF BEDROCK IS ANTICIPATED, THE APPLICANT SHALL SUBMIT A BLASTING PLAN THAT IDENTIFIES:
- WHERE THE BLASTING ACTIVITIES ARE ANTICIPATED TO OCCUR;
- THE ESTIMATED QUANTITY OF BLAST ROCK IN CUBIC YARDS; AND
- SITE-SPECIFIC BLASTING BEST MANAGEMENT PRACTICES.

ABBREVIATIONS

Table with 4 columns: Symbol, Description, Unit/Type, and Material/Specification. Includes entries for Building, Centerline, Corrugated Metal Pipe, Ductile Iron Diameter, Force Main, Gallon, High Density Polyethylene, Inside Diameter, and Intersection.

LEGEND:

ITEMS SHOWN MAY NOT APPEAR ON PLANS

Legend table with columns: Description, Existing, Proposed. Lists various symbols for Property Line, Benchmark, Survey Station, Iron Pin, Drill Hole, Bound, Test Pit, Sewer Manhole, Gas Valve, Utility Pole, Guy Anchor, Electrical Manhole, Transformer, Pull Box, Well, Water Valve, Water Shutoff, Hydrant, Air Relief Valve, Drainage Manhole, Catch Basin, Curb Inlet, Parking Light, Flood Light, Site Light, Sign, Trash Can, Flagpole, Monitoring Well, Edge of Gravel, Edge of Pavement, Curbing, Major Foot Contour, Minor Foot Contour, Waterline, Storm Drain, Under Drain, Sanitary Sewer, Force Main, Overhead Utilities, Underground Utilities, Gas Line, Chain Link Fence, Guardrail, Silts Fence, Tree Line, Gravel Surface, Paved Surface, Concrete Surface, Building Footprint, Wetlands, Riprap.

ZONING MAP



Legend for Character Districts and Residential Districts. Character-Based Zoning Area (Refer to Zoning Map Sheet 2 of 2 Character Districts Regulating Plan). Residential Districts: R (Rural), SRA (Single Residence A), SRB (Single Residence B), GRA (General Residence A), GRB (General Residence B), GRC (General Residence C), GA/MH (Garden Apartment/Mobile Home Park). Other Districts: M (Municipal), NRP (Natural Resource Protection), TC (Transportation Corridor).

Revision table with columns: REV, DATE, DESCRIPTION, BY, CHK. Includes entry for 2026.02.13 ISSUED FOR COMMENT by JHV and SMT.

ISSUED FOR PERMITTING

HALEY WARD logo and contact information: 200 Griffin Rd., Unit 14, Portsmouth, New Hampshire 03801, 603.430.9282. Website: WWW.HALEYWARD.COM.

PROJECT: PROPOSED 2 LOT SUBDIVISION, RICHARDS AVE & SOUTH ST, PORTSMOUTH NH

TITLE: GENERAL NOTES, LEGEND & ABBREVIATIONS

Professional Engineer seal for Shawn M. Tobey, No. 14121, State of New Hampshire. Drawing information: DATE 2026.02.13, SCALE NTS, DRAWN BY JHV, DESIGNED BY JHV, CHECKED BY SMT, PROJECT No. 5010220.003, DRAWING No. C001, REV. 1.

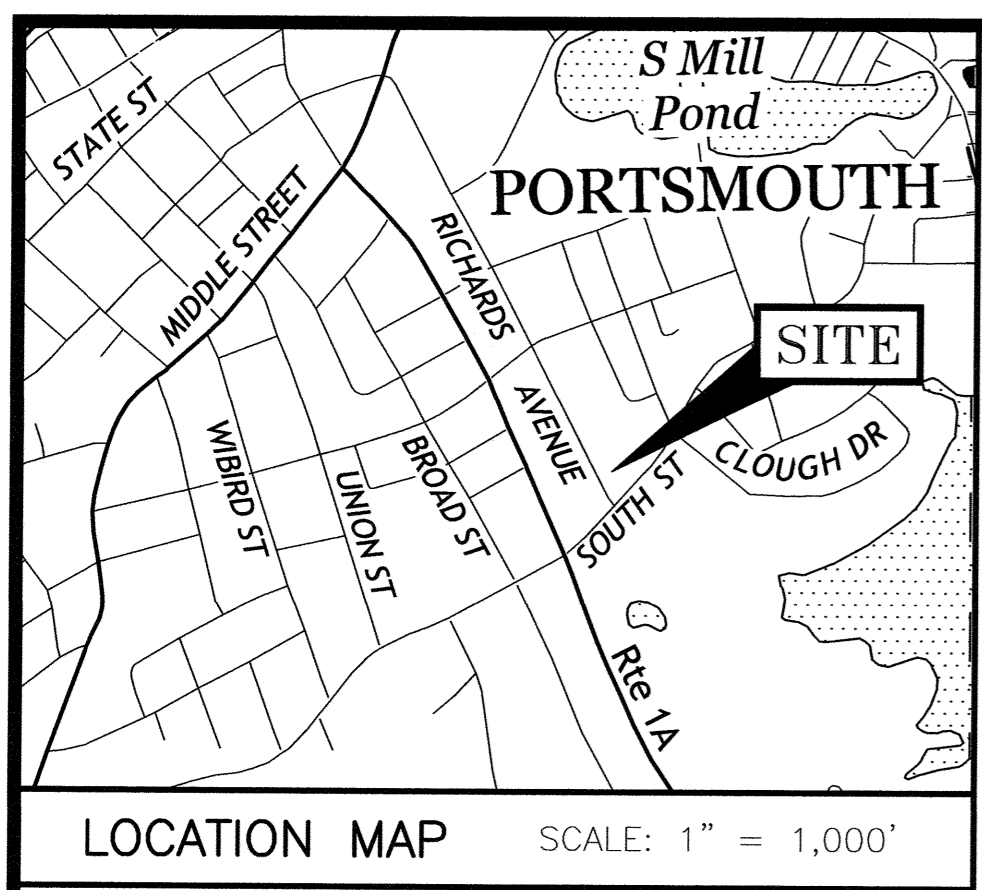

LEGEND:

DESCRIPTION	EXISTING
RCRD 1234/123	ROCKINGHAM COUNTY REGISTRY OF DEEDS DEED BOOK/PAGE
N/F	NOW OR FORMALLY TO BE SET
TBS	TYPICAL
VCC	VERTICAL GRANITE CURB
FENCE	X X
OVERHEAD UTILITY LINE	OHU OHU

LENGTH TABLE

LINE	BEARING	DISTANCE
L1	N46°01'10"W	11.67'
L2	N42°33'08"E	9.71'

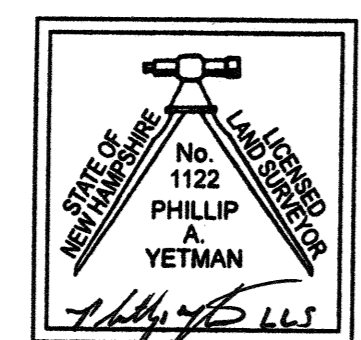

APPROVED BY THE PORTSMOUTH PLANNING BOARD

CHAIRMAN _____ DATE _____

"I CERTIFY THAT THIS PLAN WAS PREPARED UNDER MY DIRECT SUPERVISION, THAT IT IS THE RESULT OF A FIELD SURVEY BY THIS OFFICE AND HAS AN ACCURACY OF THE CLOSED TRAVERSE THAT EXCEEDS THE PRECISION OF 1:15,000."

Phillip A. Yetman
 PHILLIP A. YETMAN, LLS 1122
 3/2/2026
 DATE

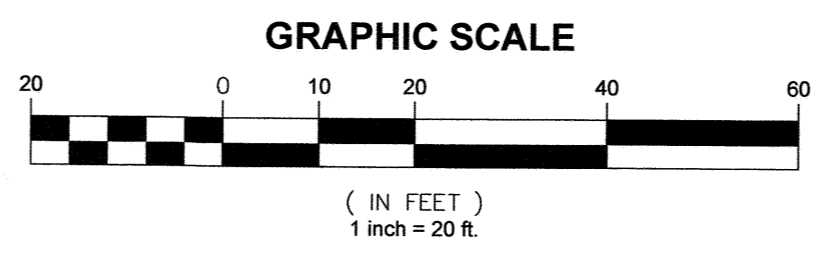
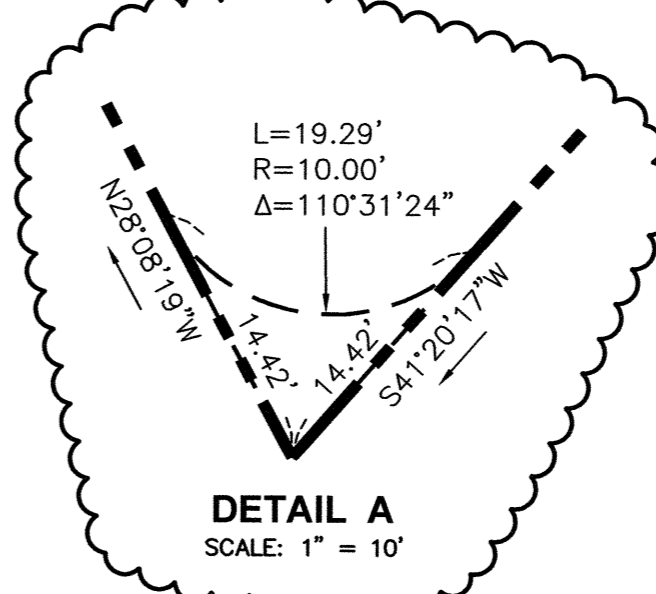
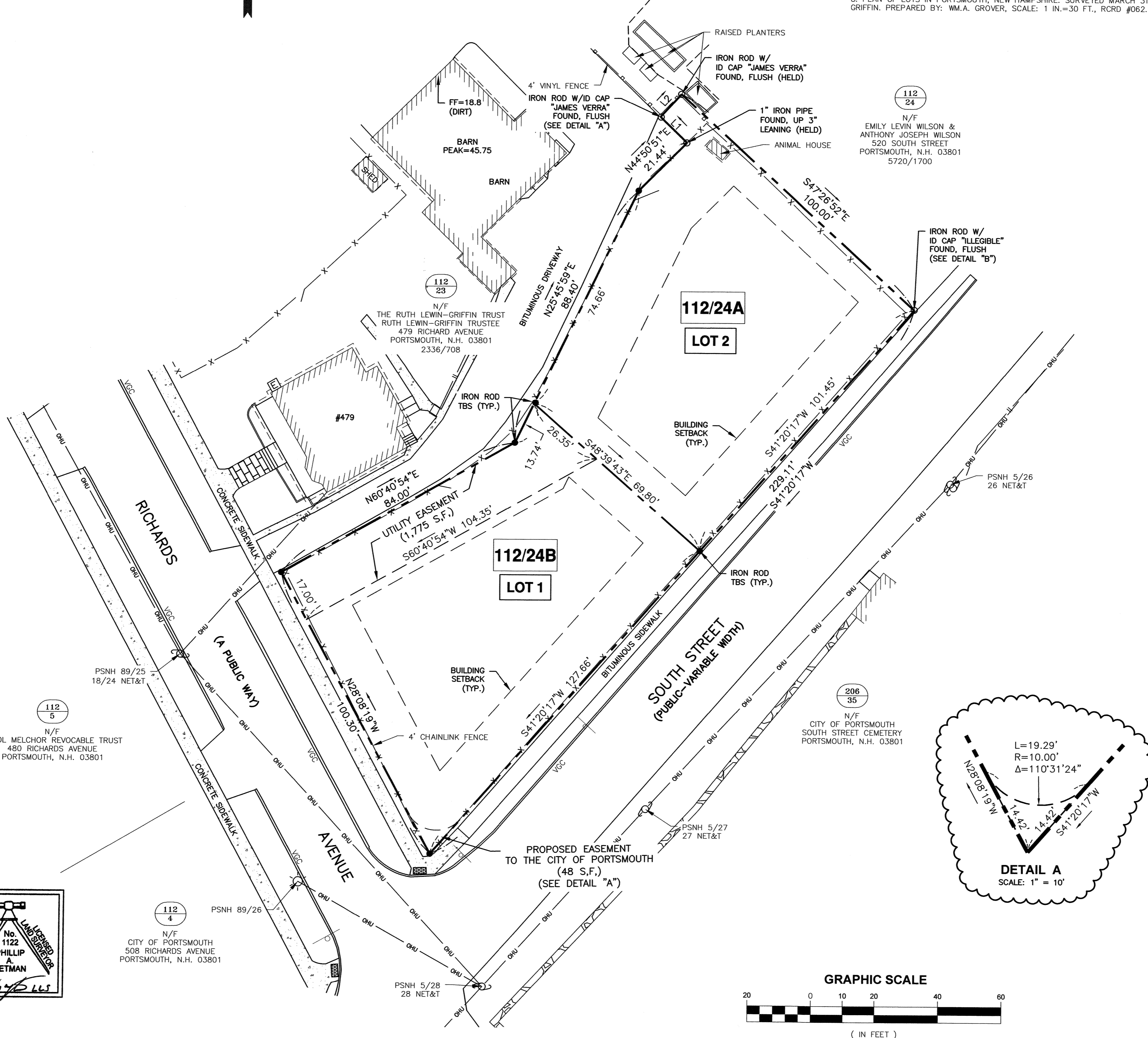

PLAN REFERENCES:

1. LOT LINE RELOCATION PLAN TAX MAP 112 - LOT 23 & 24A, MAP 112, LOT 23 OWNERS: THE RUTH LEWIN-GRIFFIN TRUST, MICHAEL GRIFFIN, ESTATE EXECUTIVE; MAP 112, LOT 24A, J. PAUL GRIFFIN FAMILY TRUST (AKA THE GRIFFIN FAMILY TRUST) PETER J. GRIFFIN, TRUSTEE, 479 RICHARDS AVENUE & SOUTH STREET CITY OF PORTSMOUTH, COUNTY OF ROCKINGHAM STATE OF NEW HAMPSHIRE DATED NOVEMBER 31, 2025.
2. LOT LINE REVISION PLAN 520 SOUTH STREET PORTSMOUTH, NEW HAMPSHIRE, ASSESSOR'S PARCELS 112-24 & 112-29 FOR: NEAL I. KATZ LIVING TRUST, NEAL I. KATZ TRUSTEE. PREPARED BY: JAMES VERRA AND ASSOCIATES, INC., DATED: 10-27-2014, SCALE: 1"=20', RCRD D-38647.
3. LOT LINE REVISION SOUTH STREET PORTSMOUTH, NEW HAMPSHIRE FOR GRIFFIN FAMILY CORP., PREPARED BY: JAMES VERRA AND ASSOCIATES, INC., DATED: 9/24/98, SCALE: 1"=30', RCRD D-26740.
4. SUBDIVISION & LOT LINE REVISION PLAN OF LAND, SOUTH STREET & ELWYN AVENUE PORTSMOUTH, NEW HAMPSHIRE FOR GRIFFIN FAMILY CORP., PREPARED BY: JAMES VERRA AND ASSOCIATES, INC., DATED: 4/21/97, SCALE: 1"=30', RCRD D-25545.
5. STANDARD BOUNDARY SURVEY TAX MAP 112-LOT 20, OWNERS OF RECORD: THOMAS A. NIES REVOCABLE TRUST OF 2010 & DENISE M. NIES REVOCABLE TRUST OF 2010, 419 RICHARDS AVENUE, CITY OF PORTSMOUTH, COUNTY OF ROCKINGHAM, STATE OF NEW HAMPSHIRE. PREPARED BY: AMBIT ENGINEERING, INC., DATED: APRIL 2019 AND REVISED 4/25/19. SCALE: 1"=10'. NOT RECORDED.
6. PLAN OF LAND OWNED BY ALFRED L. ELWYN, PORTSMOUTH, N.H., COMPILED FROM A SURVEY MADE 1899 BY A.C. HOYT C.E., DATED: AUG. 1899, SCALE: 100 FT. TO AN INCH, RCRD #00176.
7. PLAN OF LOTS BELONGING TO TRAFTON, SITUATED IN PORTSMOUTH, N.H., RCRD #00168.
8. PLAN OF LOTS IN PORTSMOUTH, NEW HAMPSHIRE, SURVEYED MARCH 31, 1914 FOR M.J. GRIFFIN. PREPARED BY: W.M.A. GROVER, SCALE: 1 IN.=30 FT., RCRD #062.

HALEY WARD
 ENGINEERING | ENVIRONMENTAL | SURVEYING
 200 Griffin Rd. Unit 14
 Portsmouth, New Hampshire 03801
 603.430.9282
 WWW.HALEYWARD.COM

- NOTES:**
1. PARCELS ARE SHOWN ON THE CITY OF PORTSMOUTH ASSESSOR'S MAP 112, LOT 24A.
 2. OWNER OF RECORD MAP 112, LOT 24A, SOUTH STREET:
 J. PAUL GRIFFIN FAMILY TRUST
 (AKA THE GRIFFIN FAMILY TRUST)
 PETER J. GRIFFIN, TRUSTEE
 P.O. BOX 149
 PORTSMOUTH, N.H. 03801
 DEED BOOK 6640, PAGE 1025
 3. PARCELS ARE NOT IN A SPECIAL FLOOD HAZARD AREA AS SHOWN ON FIRM PANEL 33015C0259F. EFFECTIVE JANUARY 29, 2021.
 4. EXISTING LOT AREA: 17,459 S.F. 0.4008 ACRES
 PROPOSED LOT AREA:
 LOT 1 8,894 S.F. 0.2042 ACRES
 LOT 2 8,566 S.F. 0.1966 ACRES
 5. PARCELS ARE LOCATED IN THE GENERAL RESIDENCE A (GRA) DISTRICT.
 6. DIMENSIONAL REQUIREMENTS:
 MINIMUM LOT AREA 7,500 S.F.
 MINIMUM STREET FRONTAGE: 100 FEET
 MINIMUM DEPTH 70 FEET
 SETBACKS: FRONT 15 FEET
 SIDE 10 FEET
 REAR 20 FEET
 MAXIMUM STRUCTURE HEIGHT:
 FLAT ROOF 30 FEET
 SLOPPED ROOF 35 FEET
 ROOF APPURTENANCE 8 FEET
 MAXIMUM BUILDING COVERAGE 25%
 MINIMUM OPEN SPACE 30%
 7. THE PURPOSE OF THIS PLAN IS TO SHOW A 2 LOT SUBDIVISION OF ASSESSOR'S MAP 112, LOT 24A IN THE CITY OF PORTSMOUTH.
 8. VERTICAL DATUM IS NAVD88. BASIS OF VERTICAL DATUM IS REDUNDANT RTN GNSS OBSERVATIONS.
 9. ABUTTER INFORMATION TAKEN FROM THE CITY OF PORTSMOUTH ASSESSORS GIS WEBSITE.

REV.	DATE	DESCRIPTION	BY	CHK.
1	03/02/2026	CITY EASEMENT		PAY PAY
0	02/10/2026	ISSUED FOR COMMENT		PAY PAY

SITE SURVEY

**SUBDIVISION PLAN OF LAND
 TAX MAP 112 - LOT 24A**

OWNER:
 MAP 112, LOT 24A
 J. PAUL GRIFFIN FAMILY TRUST
 (AKA THE GRIFFIN FAMILY TRUST)
 PETER J. GRIFFIN, TRUSTEE
 PROPERTY LOCATED AT:
 SOUTH STREET
 CITY OF PORTSMOUTH
 COUNTY OF ROCKINGHAM
 STATE OF NEW HAMPSHIRE

SITE NOTES:

- THE PURPOSE OF THIS PLAN IS TO SHOW A PRELIMINARY RESIDENTIAL DEVELOPMENT WITH ASSOCIATED SITE IMPROVEMENTS, GRADING, DRAINAGE, AND UTILITIES TO SHOW COMPLIANCE WITH THE ZONING ORDINANCE. THE FINAL DESIGN SHALL BE SUBMITTED AND APPROVED AS PART OF THE BUILDING PERMIT APPLICATION.
- REFER TO DWG C001 FOR GENERAL NOTES, LEGEND, AND ABBREVIATIONS.
- PARCEL IS SHOWN ON THE CITY OF PORTSMOUTH ASSESSOR'S MAP 112 AS LOT 24A.
- OWNER OF RECORD:
J. PAUL GRIFFIN FAMILY TRUST
(AKA THE GRIFFIN FAMILY TRUST)
PETER J. GRIFFIN, TRUSTEE
P.O. BOX 149
PORTSMOUTH, NH 03801
DEED BOOK 6640, PAGE 1025
- PARCEL IS NOT IN A SPECIAL FLOOD HAZARD AREA AS SHOWN ON FIRM PANEL 33015C0259F, EFFECTIVE JANUARY 29, 2021.
- EXISTING LOT AREA:
17,459 S.F.
0.4008 ACRES
- PARCEL IS LOCATED IN THE GENERAL RESIDENCE A (GRA) DISTRICT.
- DIMENSIONAL REQUIREMENTS:
MINIMUM LOT AREA: 7,500 S.F.
MINIMUM STREET FRONTAGE: 100 FEET
MINIMUM DEPTH: 70 FEET
SETBACKS: FRONT: 15 FEET, SIDE: 10 FEET, REAR: 20 FEET
MAXIMUM STRUCTURE HEIGHT:
FLAT ROOF: 30 FEET
SLOPPED ROOF: 35 FEET
ROOF APPURTENANCE: 8 FEET
MAXIMUM BUILDING COVERAGE: 25%
MINIMUM OPEN SPACE: 30%
- VERTICAL DATUM IS NAVD88. BASIS OF VERTICAL DATUM IS REDUNDANT RTN GNSS OBSERVATIONS.
- ABUTTER INFORMATION TAKEN FROM THE CITY ASSESSORS GIS WEBSITE.
- TRASH PICKUP TO BE CURBSIDE.
- EACH DWELLING UNIT TO INCLUDE (2) CAR PARKING WITHIN ATTACHED GARAGE AND (2) SURFACE PARKING SPACES WITHIN DRIVEWAY.

TABLE OF DIMENSIONAL STANDARDS:

REGULATION	REQUIREMENT	LOT (1)	LOT (2)
MIN. LOT AREA	7,500 S.F.	8,894 S.F.	8,565 S.F.
STREET FRONTAGE	100.0 FEET	228.0 FEET	101.4 FEET
MIN. FRONT SETBACK	15.0 FEET	18.0 FEET	18.0 FEET
MIN. SIDE SETBACK	10.0 FEET	19.8 FEET	16.2 FEET
MIN. REAR SETBACK	20.0 FEET	20.2 FEET	27.0 FEET
MAX. HEIGHT SLOPPED ROOF	35.0 FEET	< 35.0 FEET	< 35.0 FEET
MAX. BUILDING COVERAGE ¹	25%	22.8%	24.9%
MIN. OPEN SPACE	30%	66.9%	64.4%

DIMENSIONAL NOTES:

- MAX. BUILDING COVERAGE INCLUDES DECK AND STAIR.

IMPERVIOUS SURFACE AREAS:
(TO PROPERTY LINES)

COVERAGE	LOT (1)	LOT (2)
PAVEMENT	639 S.F.	639 S.F.
WALKWAYS	84 S.F.	84 S.F.
PATIOS	160 S.F.	160 S.F.
STOOP	32 S.F.	32 S.F.
DECKS	0 S.F.	104 S.F.
BUILDINGS	2,028 S.F.	2,028 S.F.
TOTAL	2,943 S.F.	3,047 S.F.
% LOT COVERAGE	33.1%	35.6%

CONDITIONS OF APPROVAL:

- ALL CONDITIONS ON THIS PLAN SHALL REMAIN IN EFFECT IN PERPETUITY PURSUANT TO THE REQUIREMENTS OF THE SITE PLAN REVIEW REGULATIONS.
- THIS SITE PLAN SHALL BE RECORDED IN THE ROCKINGHAM COUNTY REGISTRY OF DEEDS.
- ALL IMPROVEMENTS SHOWN ON THIS SITE PLAN SHALL BE CONSTRUCTED AND MAINTAINED IN ACCORDANCE WITH THE PLAN BY THE PROPERTY OWNER AND ALL FUTURE PROPERTY OWNERS. NO CHANGES SHALL BE MADE TO THIS SITE PLAN WITHOUT THE EXPRESS APPROVAL OF THE PORTSMOUTH PLANNING DIRECTOR.

"I CERTIFY THAT THIS PLAN WAS PREPARED UNDER MY DIRECT SUPERVISION, THAT IT IS THE RESULT OF A FIELD SURVEY BY THIS OFFICE AND HAS AN ACCURACY OF THE CLOSED TRAVERSE THAT EXCEEDS THE PRECISION OF 1:15,000."

APPROVED BY THE PORTSMOUTH PLANNING BOARD

CHAIRMAN _____ DATE _____

JOHN R. CHAGNON, LLS _____ DATE _____

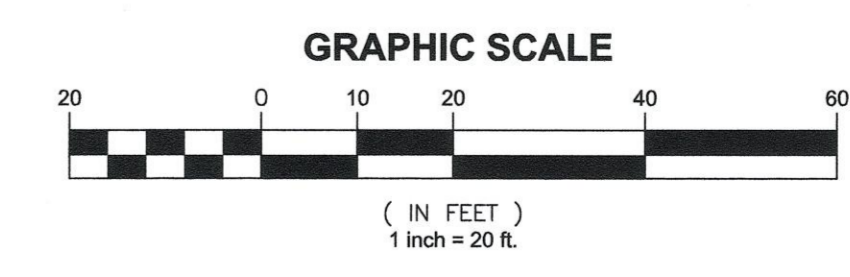
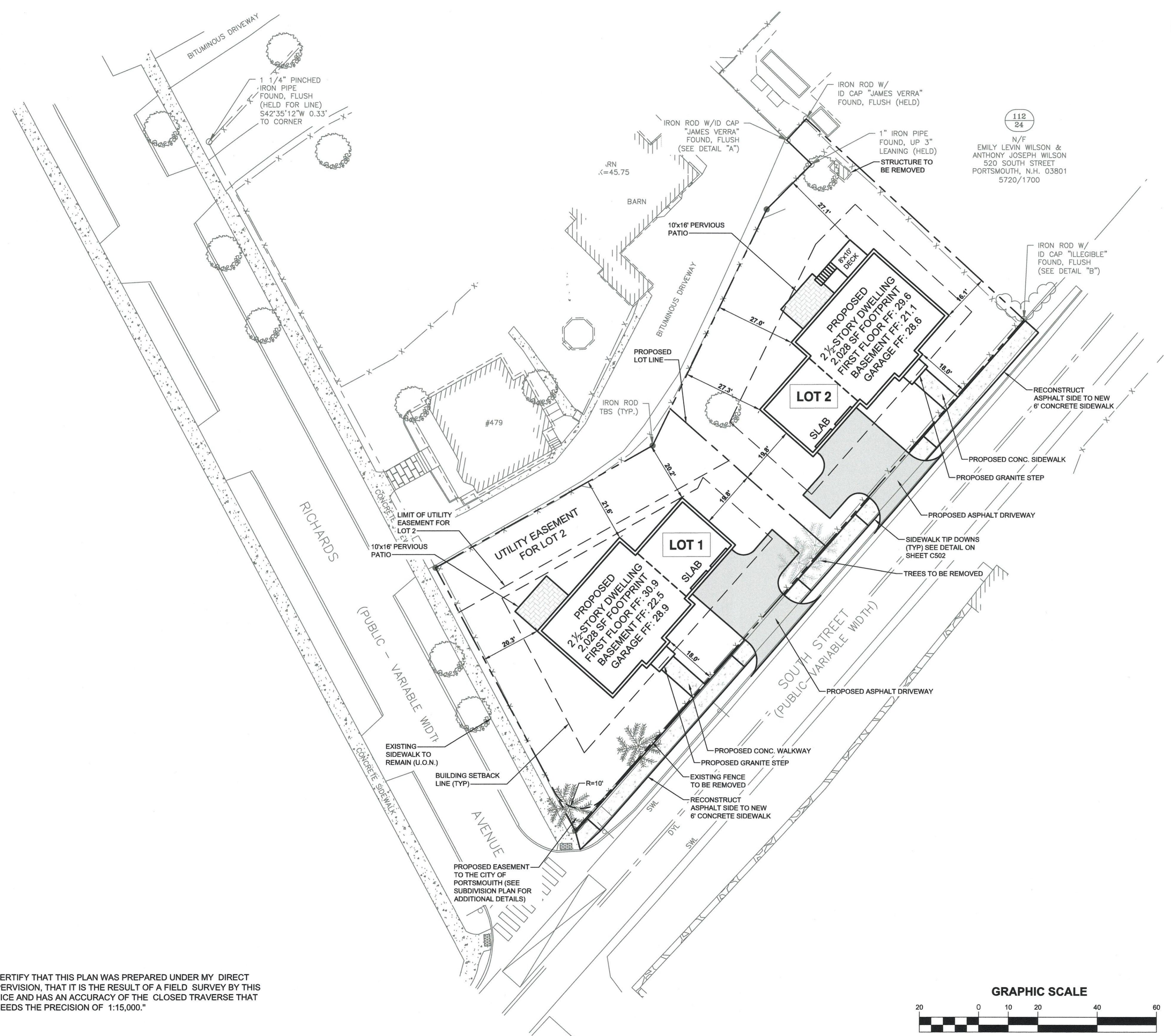
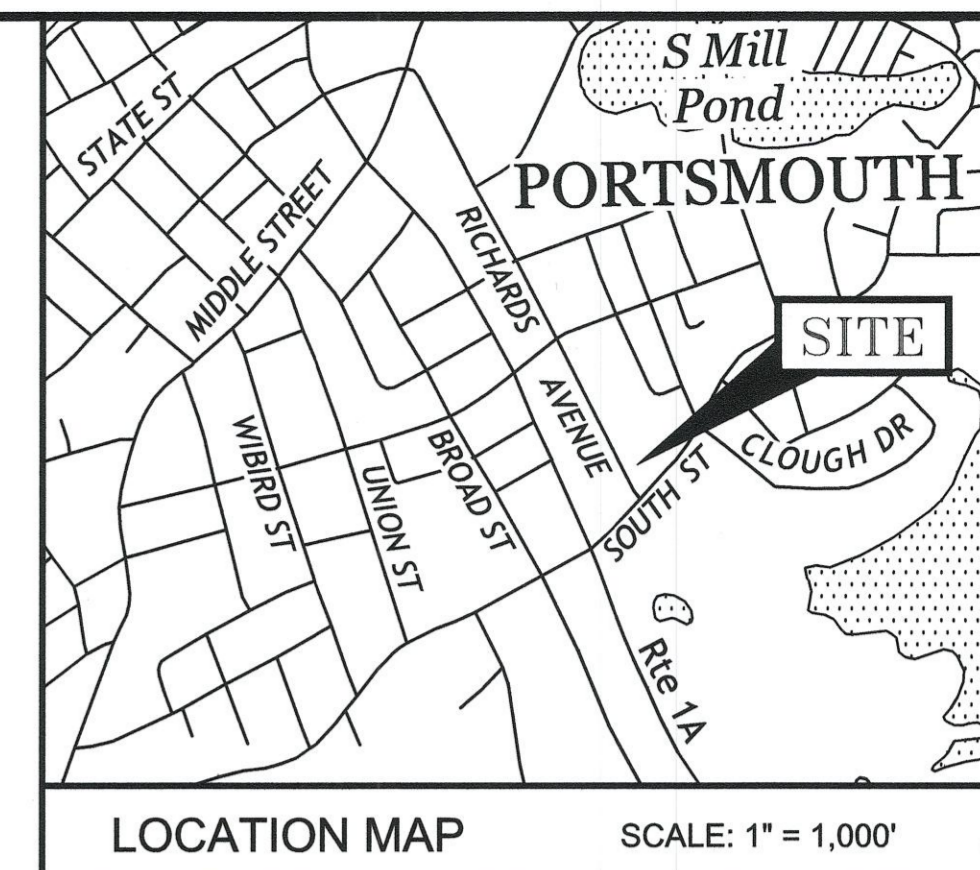

REV.	DATE	DESCRIPTION	BY	CHK
3	2026.03.25	ADDED APPROVAL BLOCK	JHV	SMT
2	2026.03.02	REVISED PER TAC COMMENTS	JHV	SMT
1	2026.02.13	ISSUED FOR COMMENT	JHV	SMT

ISSUED FOR REVIEW



PROJECT: **PROPOSED 2 LOT SUBDIVISION**
RICHARDS AVE & SOUTH ST, PORTSMOUTH NH

TITLE: **SITE LAYOUT PLAN**

DATE: 2026.02.13	SCALE: 1" = 20'
DRAWN BY: JHV	DESIGNED BY: JHV
CHECKED BY: SMT	
PROJECT No.: 5010220.003	
DRAWING No.: C101	REV: 3

FILE LOCATION: P:\NH\5010220\CHANGNON_BUILBERS\5010220\CHANGNON_P\5010220.003_CSP_DWG_2026.03.24_12:38 PM

DRAINAGE NOTES:

1. THE PURPOSE OF THIS PLAN IS TO DETAIL A PRELIMINARY STORMWATER SYSTEM AND SITE UTILITIES TO SHOW COMPLIANCE WITH THE ZONING ORDINANCE. THE FINAL DESIGN SHALL BE SUBMITTED AND APPROVED AS PART OF THE BUILDING PERMIT APPLICATION.
2. REFER TO DWG C001 FOR GENERAL NOTES, LEGEND, AND ABBREVIATIONS.
3. THE FOOTING DRAINS SHALL BE CONNECTED TO THE ONSITE OUTLET PIPE AS SHOWN.
4. ALL ROOF RUNOFF SHALL BE DIVERTED TO THE UNDERGROUND STORMWATER DETENTION SYSTEM VIA DRIP STRIPS WITH UNDERDRAINS OR A GUTTER AND DOWNSPOUT COLLECTION SYSTEM.
5. VERTICAL DATUM IS NAVD88. BASIS OF VERTICAL DATUM IS REDUNDANT RTN GNSS OBSERVATIONS.
6. PORTSMOUTH STORMWATER CONNECTION PERMIT REQUIRED.

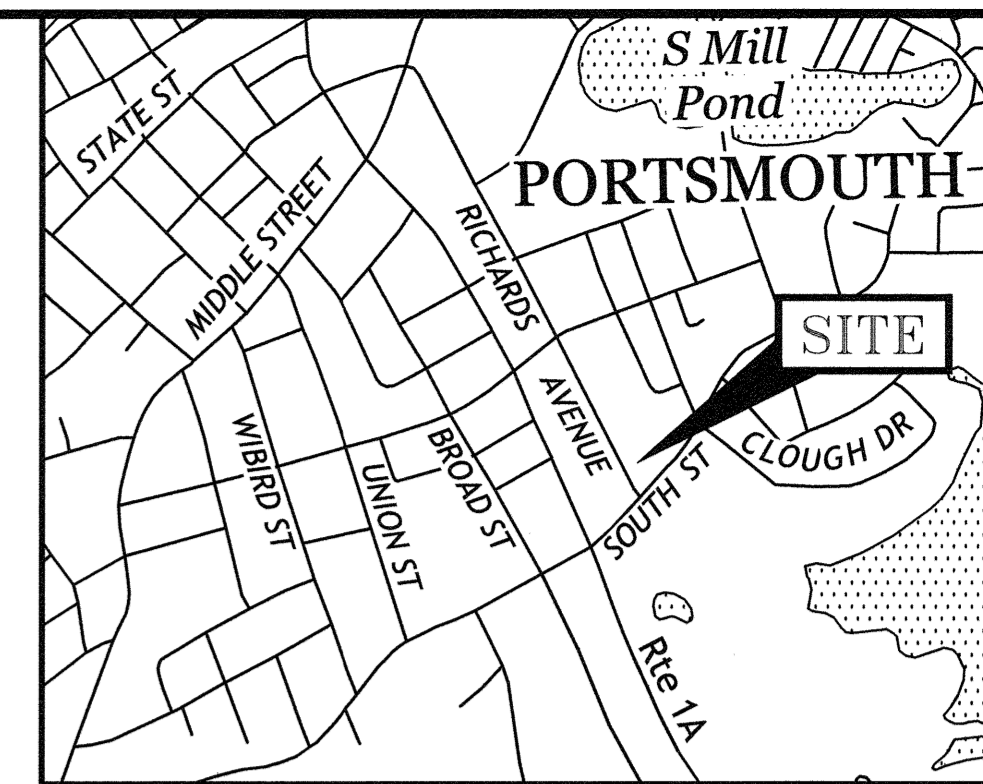

LOCATION MAP SCALE: 1" = 1,000'

- NOTES:**
- 1) THE CONTRACTOR SHALL NOTIFY DIG SAFE AT 1-888-DIG-SAFE (1-888-344-7233) AT LEAST 72 HOURS PRIOR TO COMMENCING ANY EXCAVATION ON PUBLIC OR PRIVATE PROPERTY WITHIN 100 FEET OF UNDERGROUND UTILITIES. THE EXCAVATOR IS RESPONSIBLE TO MAINTAIN MARKS. DIG SAFE TICKETS EXPIRE IN THIRTY DAYS.
 - 2) UNDERGROUND UTILITY LOCATIONS ARE BASED UPON BEST AVAILABLE EVIDENCE AND ARE NOT FIELD VERIFIED. LOCATING AND PROTECTING ANY ABOVEGROUND OR UNDERGROUND UTILITIES IS THE SOLE RESPONSIBILITY OF THE CONTRACTOR AND/OR THE OWNER. UTILITY CONFLICTS SHOULD BE REPORTED AT ONCE TO THE DESIGN ENGINEER.
 - 3) CONTRACTOR SHALL INSTALL AND MAINTAIN EROSION CONTROL MEASURES IN ACCORDANCE WITH THE "NEW HAMPSHIRE STORMWATER MANUAL, VOLUME 3, EROSION AND SEDIMENT CONTROLS DURING CONSTRUCTION. (NHDES DECEMBER 2008).

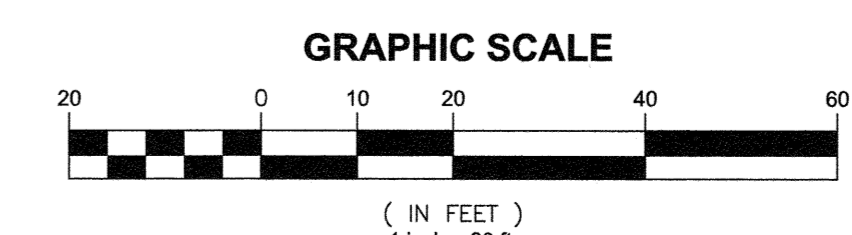
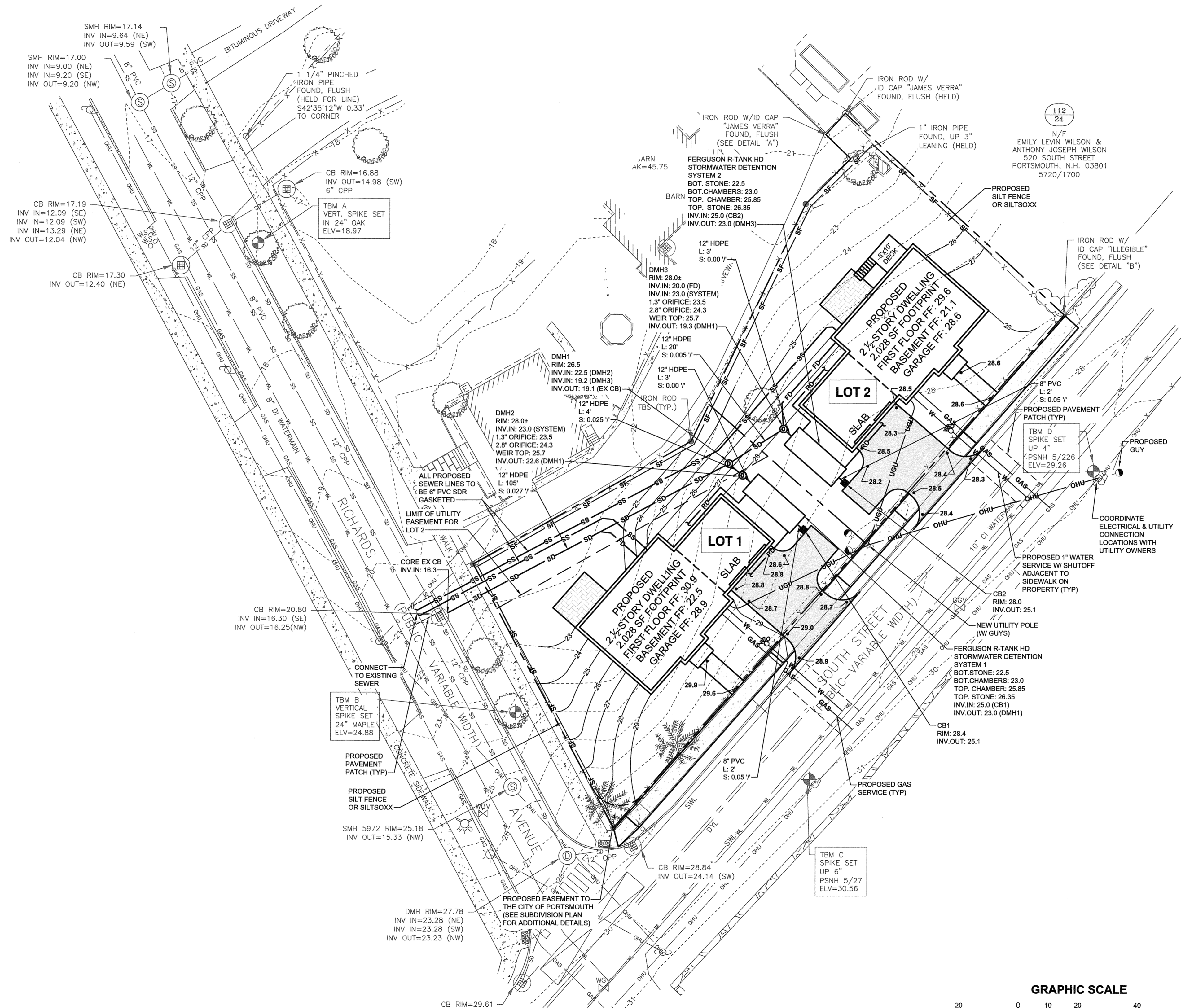

2	2026.02.02	REVISED PER TAC COMMENTS	JHV	SMT
1	2026.02.13	ISSUED FOR COMMENT	JHV	SMT
REV.	DATE	DESCRIPTION	BY	CHK.

DRAWING ISSUE STATUS

ISSUED FOR REVIEW

200 Griffin Rd., Unit 14
Portsmouth, New Hampshire 03801
603.430.9282

PROJECT

PROPOSED 2 LOT SUBDIVISION
RICHARDS AVE & SOUTH ST, PORTSMOUTH NH

TITLE

GRADING, DRAINAGE, & UTILITY PLAN

DATE	2026.02.13	SCALE	1" = 20'
DRAWN BY	JHV	DESIGNED BY	JHV
CHECKED BY	SMT	PROJECT No.	5010220.003
DRAWING No.	C102	REV.	2

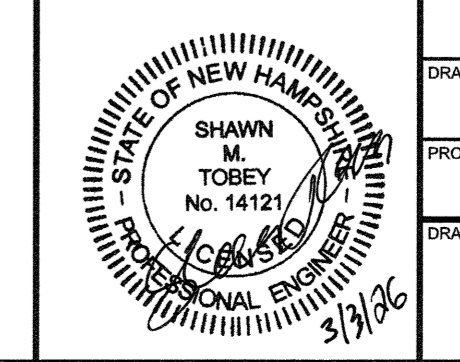

FILE LOCATION: P:\NH\2025\CHERRIBURG_BUILDBERG\CHERRIBURG_RICHARDS_AVE_413_SOUTH_AVENUE\DWG_FILES\DWG_2026.02.02_C102.dwg

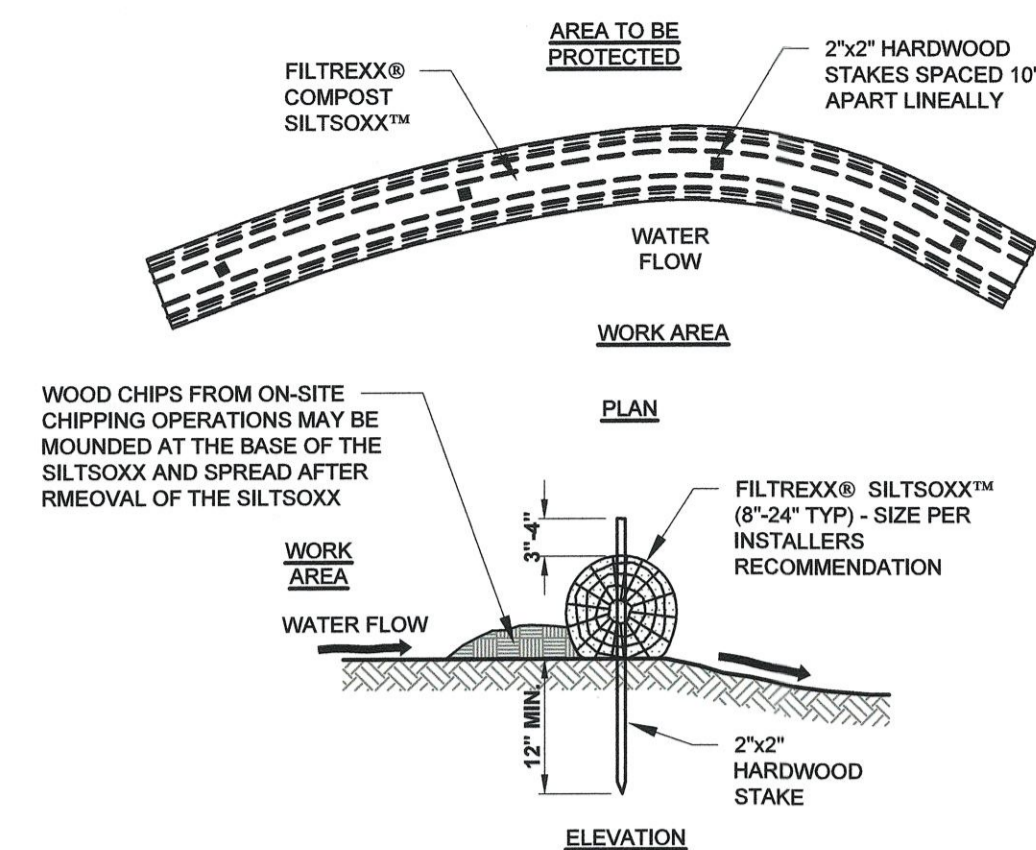

NOTES:

1. ALL MATERIAL TO MEET FILTREXX SPECIFICATIONS.
2. FILTREXX SYSTEM SHALL BE INSTALLED BY A CERTIFIED FILTREXX INSTALLER.
3. THE CONTRACTOR SHALL MAINTAIN THE COMPOST FILTRATION SYSTEM IN A FUNCTIONAL CONDITION AT ALL TIMES. IT WILL BE ROUTINELY INSPECTED AND REPAIRED WHEN REQUIRED.
4. SILT SOXX DEPICTED IS FOR MINIMUM SLOPES, GREATER SLOPES MAY REQUIRE ADDITIONAL PLACEMENTS.
5. THE COMPOST FILTER MATERIAL WILL BE DISPERSED ON SITE WHEN NO LONGER REQUIRED, AS DETERMINED BY THE ENGINEER.

FILTREXX SILT SOXX DETAIL

N.T.S.

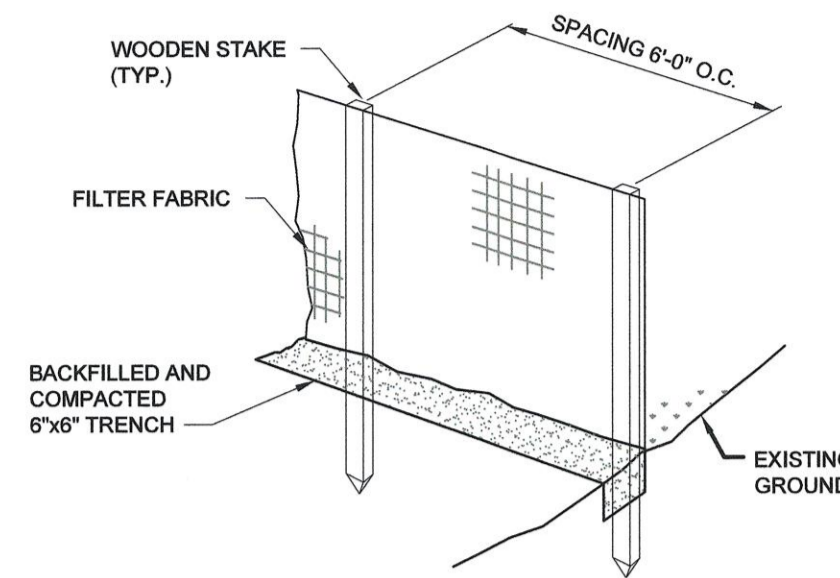

NOTES:

1. KEY FABRIC IN A 6"x6" TRENCH W/BACKFILL AND COMPACT.
2. SILT FENCE SHALL BE A 3' FENCE WITH A MINIMUM GRAB STRENGTH OF 120 LBS.

SILT FENCE DETAIL

N.T.S.

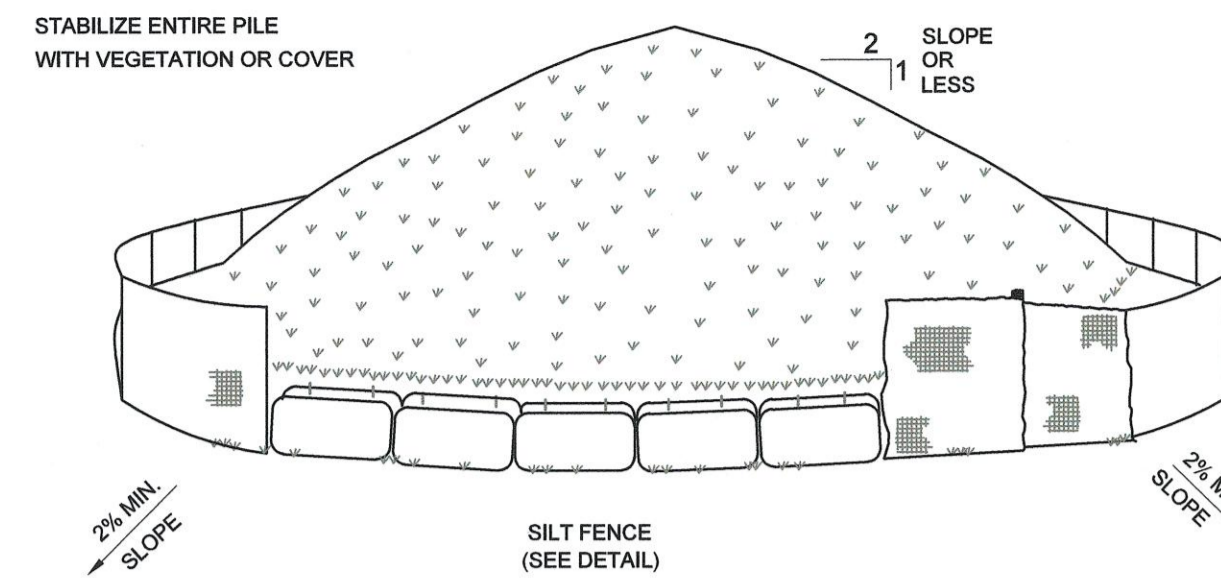

INSTALLATION NOTES:

1. AREA CHOSEN FOR STOCKPILING OPERATIONS SHALL BE DRY AND STABLE.
2. MAXIMUM SLOPE OF STOCKPILE SHALL BE 2:1.
3. UPON COMPLETION OF SOIL STOCKPILING, EACH PILE SHALL BE SURROUNDED W/ EITHER SILT FENCING, THEN STABILIZED WITH VEGETATION OR COVERED.
4. SEE SILT FENCE DETAIL ON THIS SHEET
5. TEMPORARILY STABILIZE AS NOTED IN SPECIFICATIONS

TEMPORARY STOCKPILE AREA

N.T.S.

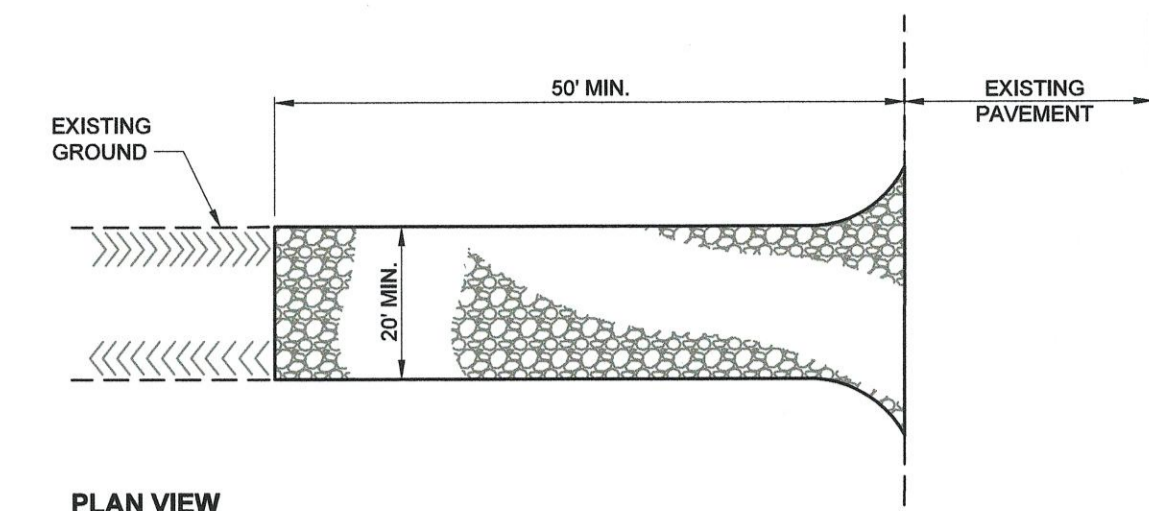

PLAN VIEW

NOTE: CONTRACTOR SHALL ADD STONE TO ENTRANCE AS MUD/SILT MATERIAL ACCUMULATES

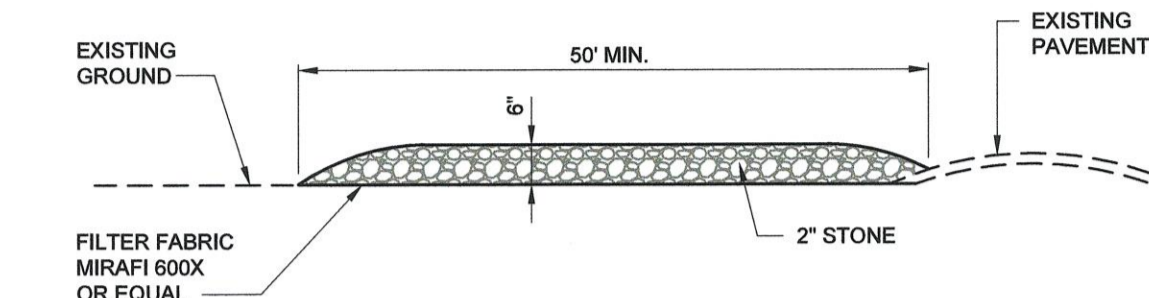

SECTION

STABILIZED CONSTRUCTION ENTRANCE DETAIL

N.T.S.

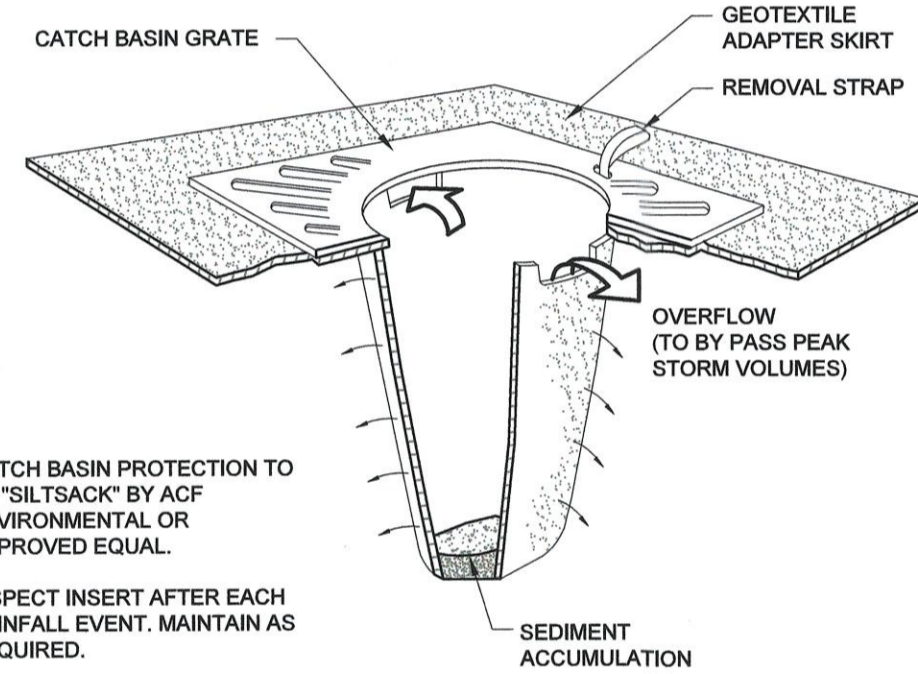

NOTES:

1. CATCH BASIN PROTECTION TO BE "SILT SACK" BY ACF ENVIRONMENTAL OR APPROVED EQUAL.
2. INSPECT INSERT AFTER EACH RAINFALL EVENT. MAINTAIN AS REQUIRED.
3. SEDIMENT WITHIN INSERT SHALL BE EMPTIED WHEN 1/2 FULL.

SEDIMENT SACK INLET PROTECTION DETAIL

N.T.S.

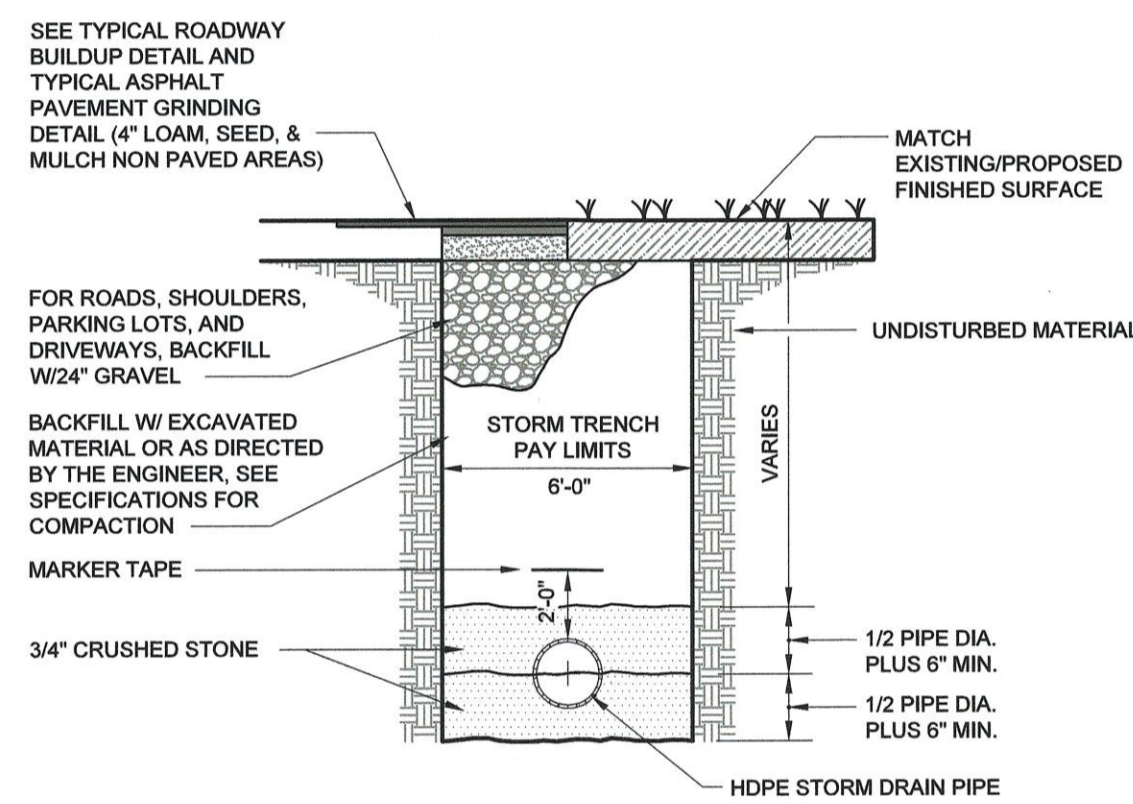

NOTE:

1. MATCH EXISTING SURFACE FINISH, EXCEPT WHERE NOTED. IN LAWN AREAS INSTALL 4" OF LOAM AND SEED AND MULCH.

TYPICAL STORM DRAIN TRENCH DETAIL

N.T.S.

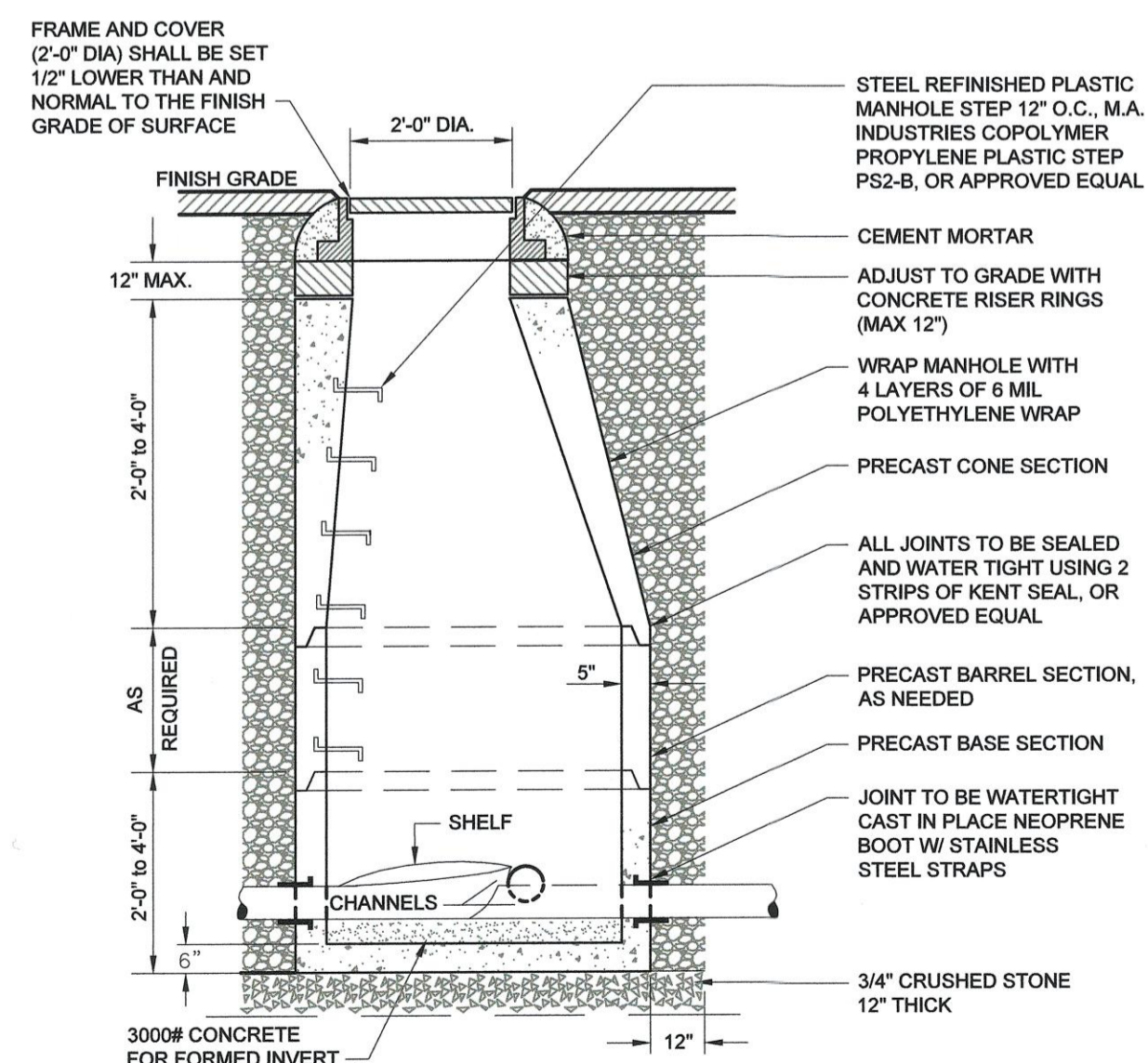

TYPICAL MANHOLE DETAIL

N.T.S.

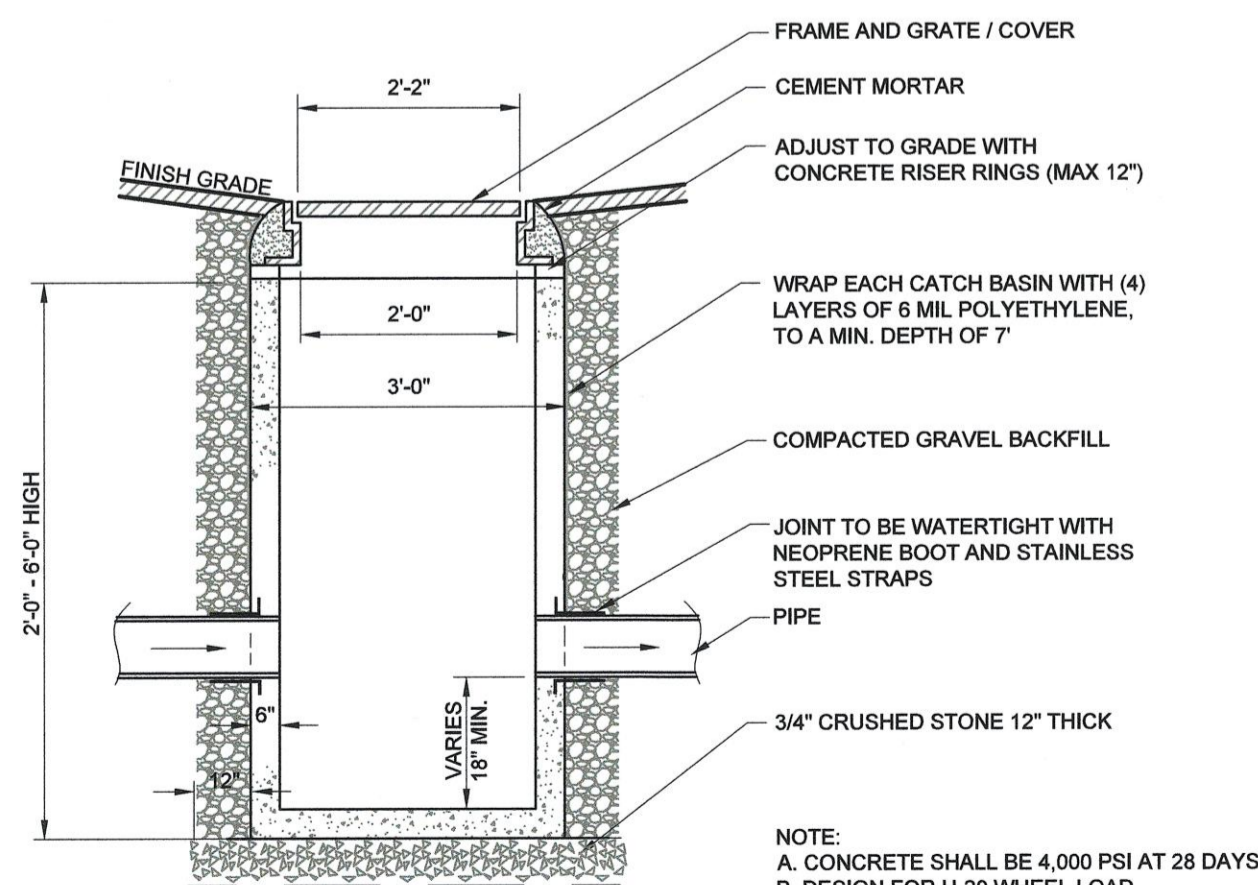

TYPICAL CATCH BASIN DETAIL

N.T.S.

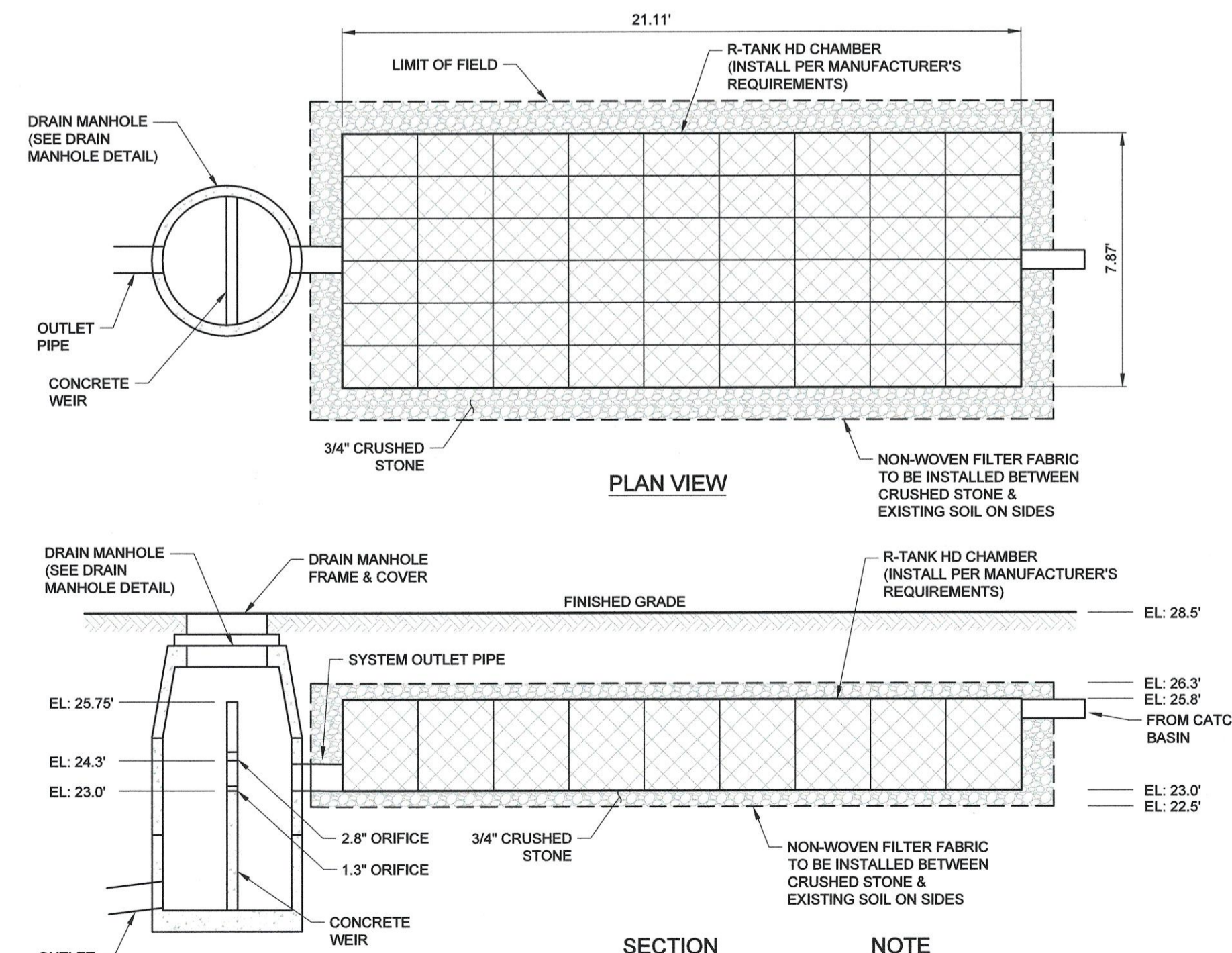

UNDERGROUND STORMWATER DETENTION SYSTEM DETAILS

N.T.S.

NOTE

1. THE APPLICANT SHALL PROVIDE A FINAL STORMWATER SYSTEM LAYOUT FOR REVIEW AND APPROVAL BY THE CITY AS PART OF THE BUILDING PERMIT APPLICATION

1	2026.02.13	ISSUED FOR COMMENT	JHV	SMT
REV.	DATE	DESCRIPTION	BY	CHK.

ISSUED FOR PERMITTING



PROPOSED 2 LOT SUBDIVISION
RICHARDS AVE & SOUTH ST, PORTSMOUTH NH

CONSTRUCTION DETAILS

DATE	2026.02.13	SCALE	NTS
DRAWN BY	JHV	DESIGNED BY	JHV
CHECKED BY	SMT		
PROJECT No.	5010220.003		
DRAWING No.	C501		
REV.	1		

FILE LOCATION: P:\NH10220\CHINBURG_BUILDFER0304-179_RICHARDS_AVE_6_SOUTH_PAV02-CAD_FILES\04\CAD\10220_003-COT.DWG, 2026.02.13, 10:04 AM

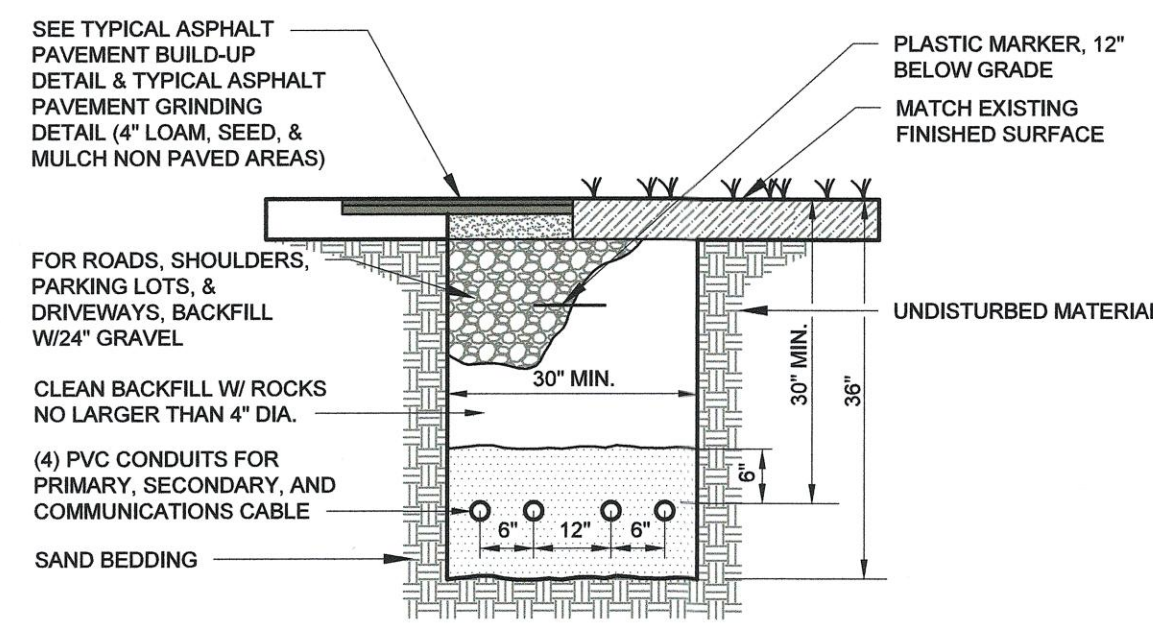

- NOTES:
1. SIZE, NUMBER, MATERIAL, AND ARRANGEMENT OF CONDUIT SHALL BE COORDINATED WITH INDIVIDUAL UTILITIES.
 2. ALL ELECTRICAL CONDUIT AND STRUCTURES SHALL BE WATER TIGHT.

TYPICAL UNDERGROUND UTILITY TRENCH DETAIL
N.T.S.

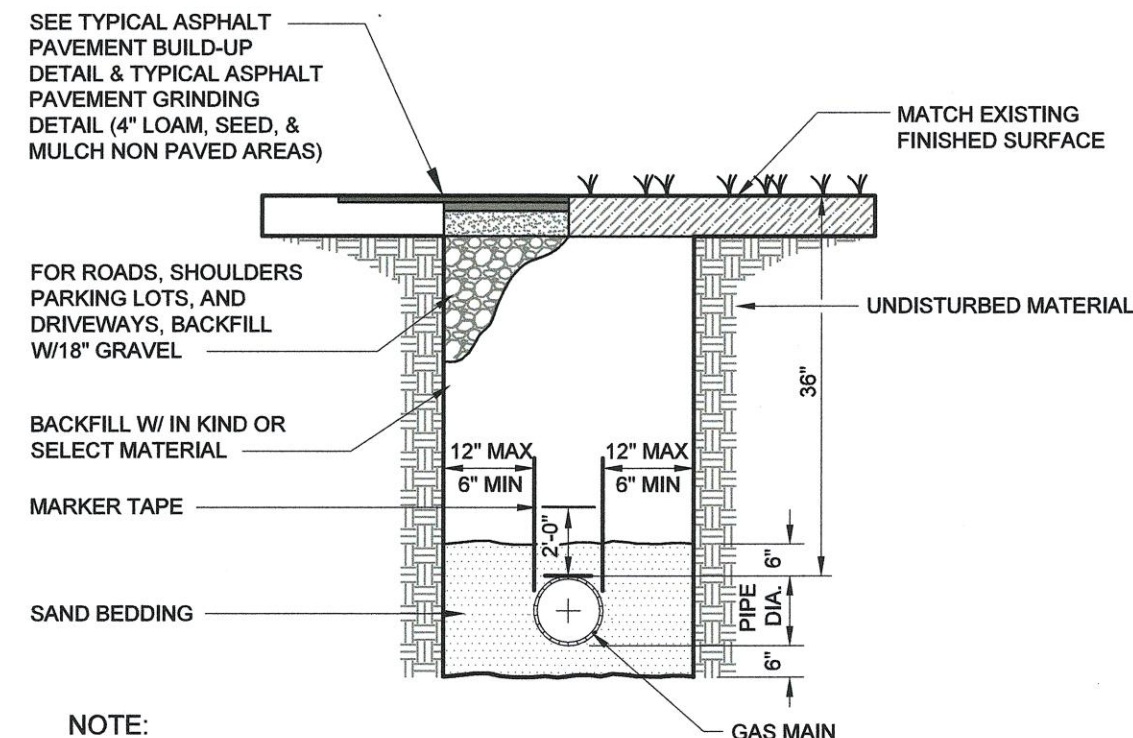

- NOTE:
1. COMPACT ALL GRANULAR MATERIAL AND BACKFILL TO 95%.
 2. SIDE CLEARANCE APPLICABLE TO BACKHOE OPERATIONS.

TYPICAL GAS TRENCH DETAIL
N.T.S.

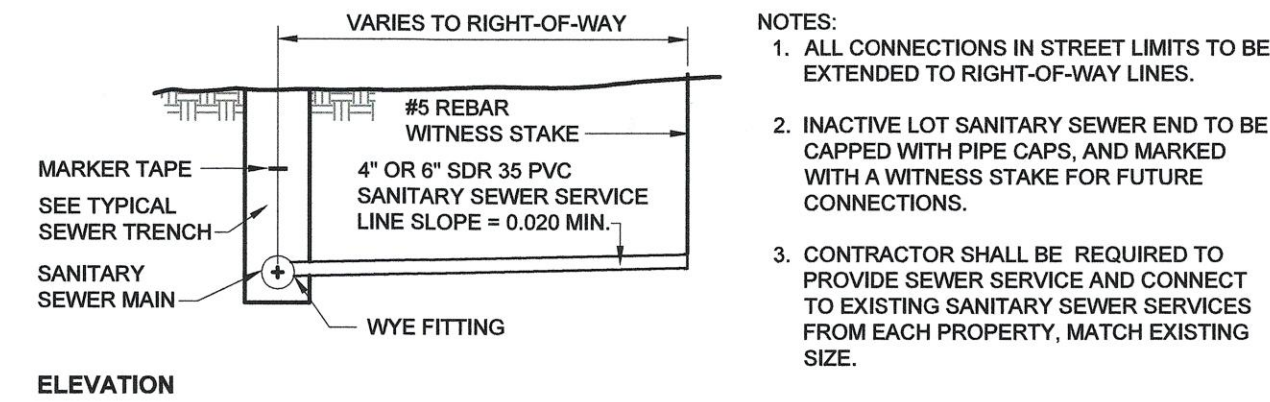

- NOTES:
1. ALL CONNECTIONS IN STREET LIMITS TO BE EXTENDED TO RIGHT-OF-WAY LINES.
 2. INACTIVE LOT SANITARY SEWER END TO BE CAPPED WITH PIPE CAPS, AND MARKED WITH A WITNESS STAKE FOR FUTURE CONNECTIONS.
 3. CONTRACTOR SHALL BE REQUIRED TO PROVIDE SEWER SERVICE AND CONNECT TO EXISTING SANITARY SEWER SERVICES FROM EACH PROPERTY, MATCH EXISTING SIZE.

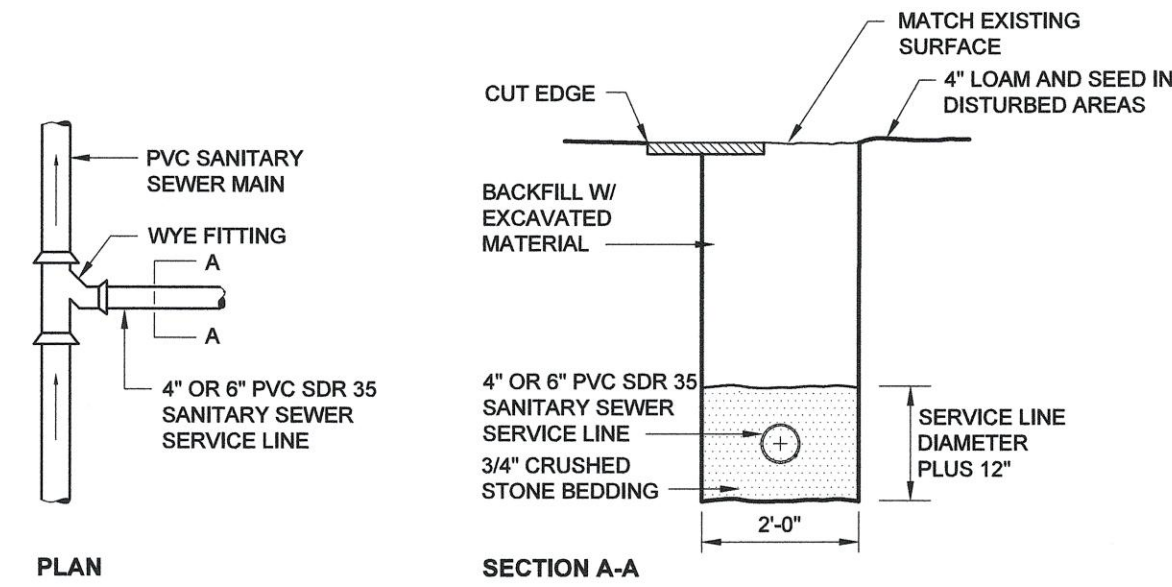

TYPICAL SANITARY SEWER SERVICE DETAIL
N.T.S.

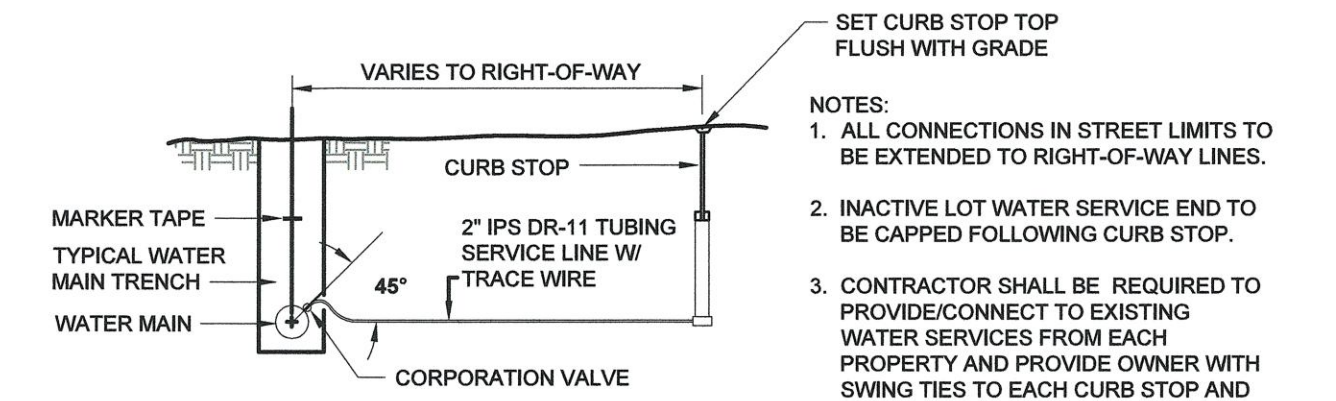

- NOTES:
1. ALL CONNECTIONS IN STREET LIMITS TO BE EXTENDED TO RIGHT-OF-WAY LINES.
 2. INACTIVE LOT WATER SERVICE END TO BE CAPPED FOLLOWING CURB STOP.
 3. CONTRACTOR SHALL BE REQUIRED TO PROVIDE CONNECTION TO EXISTING WATER SERVICES FROM EACH PROPERTY AND PROVIDE OWNER WITH SWING TIES TO EACH CURB STOP AND CORPORATION.

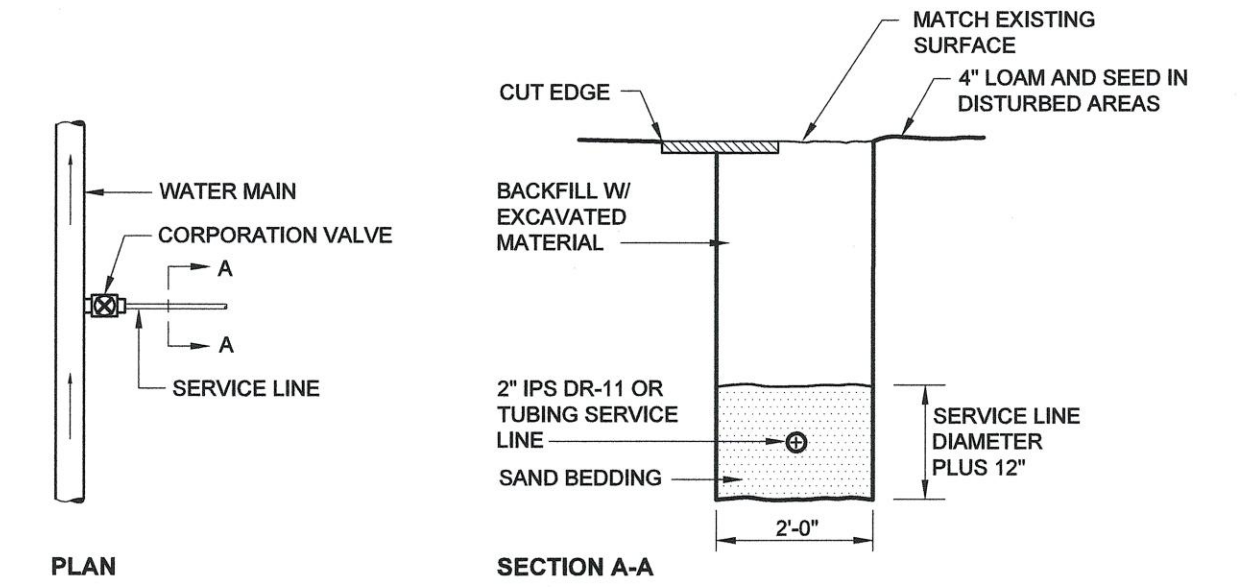

TYPICAL WATER SERVICE DETAIL
N.T.S.

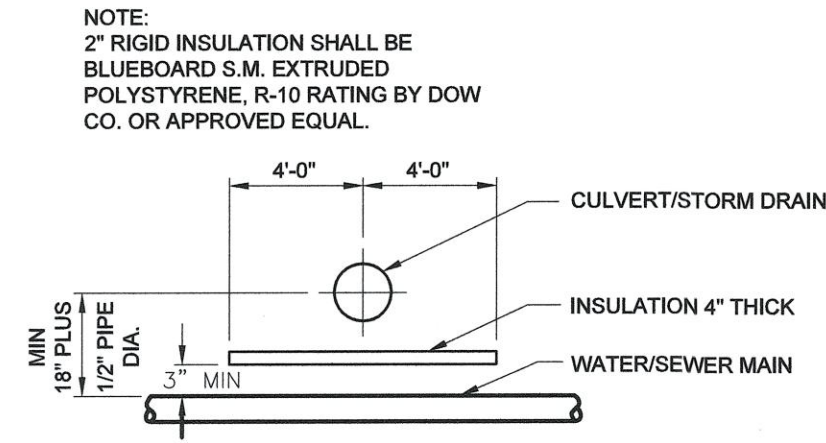

WATER/SEWER MAIN UNDER CULVERT/STORM DRAIN

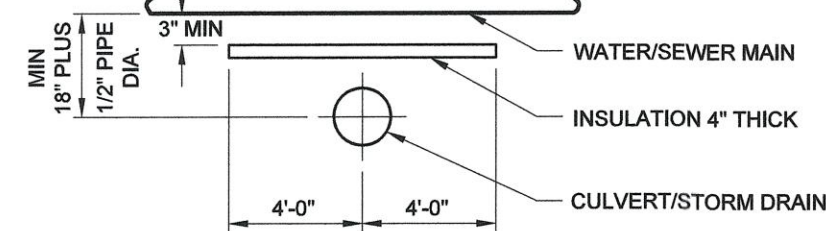

WATER/SEWER MAIN ABOVE CULVERT/STORM DRAIN

- NOTES:
1. 2\"/>
 2. INSULATION TO BE 2 FEET WIDE FOR PIPES LESS THAN 6 INCHES IN DIAMETER AND 4 FEET WIDE FOR PIPES 6 INCHES IN DIAMETER AND LARGER, OR AS DIRECTED BY THE ENGINEER.

TYPICAL PIPE CROSSING INSULATION DETAIL
N.T.S.

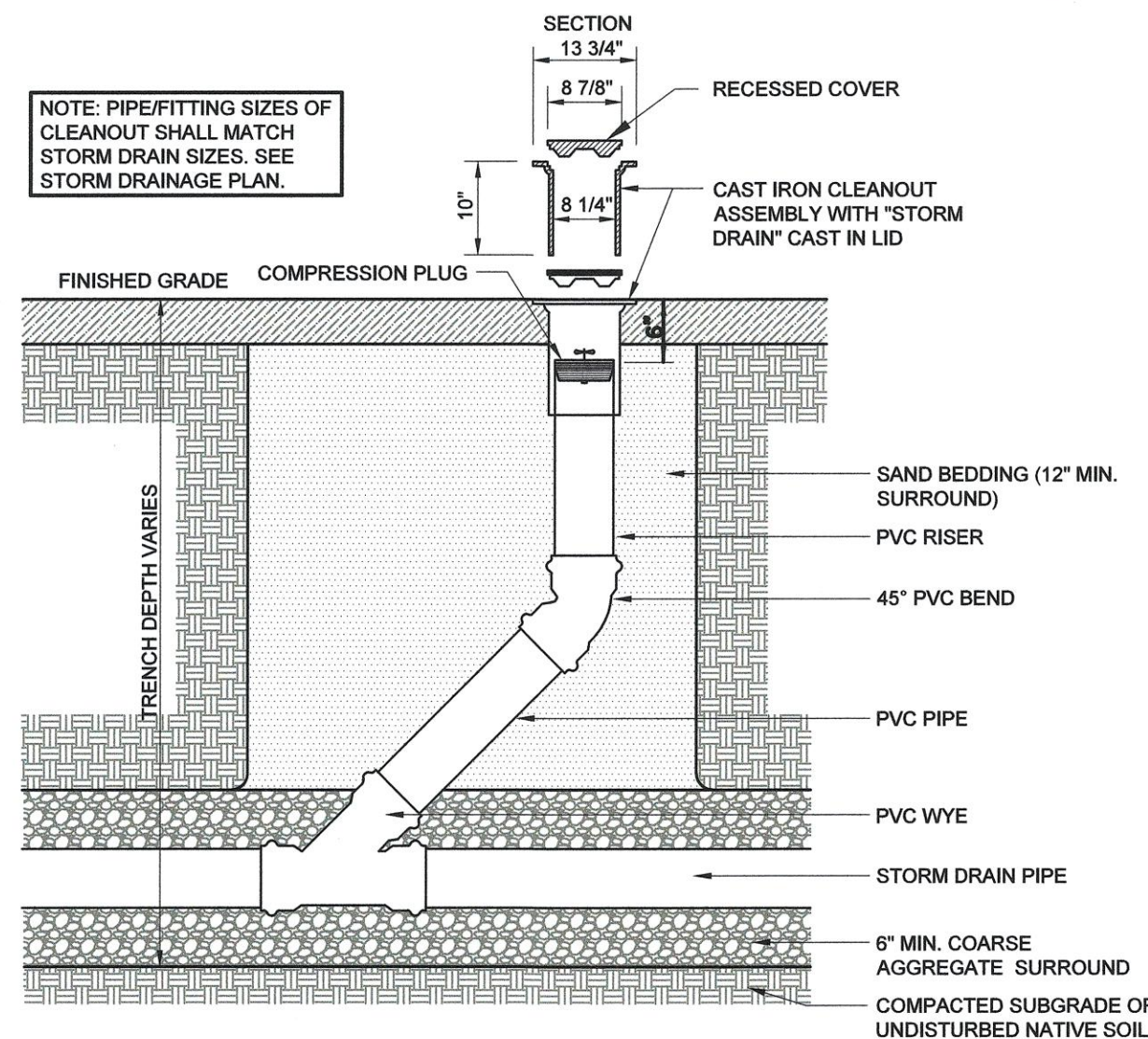

STORM DRAIN CLEANOUT DETAIL
N.T.S.

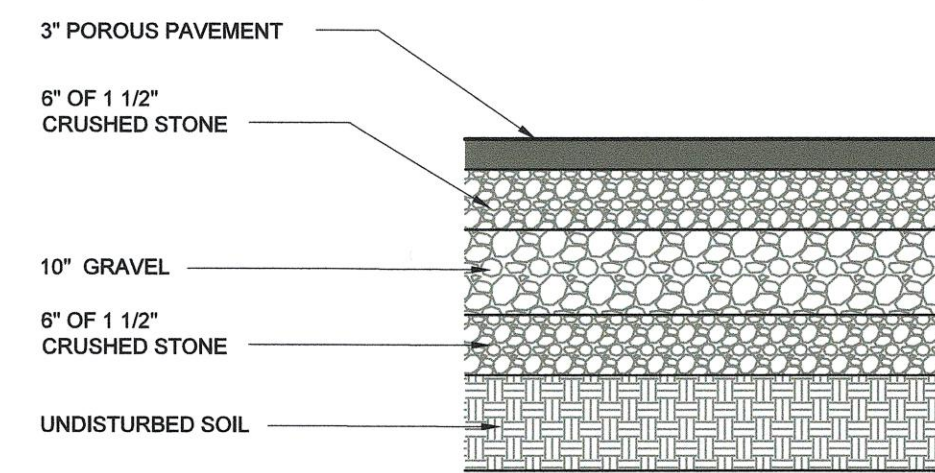

- NOTES:
1. CONTRACTOR TO PROTECT POROUS ASPHALT FROM CONTAMINATION WITH SEDIMENT DURING CONSTRUCTION.
 2. IF POROUS ASPHALT BECOMES CONTAMINATED DURING CONSTRUCTION, CONTRACTOR SHALL REMOVE AND REPLACE AT NO ADDITIONAL COST TO THE OWNER.

POROUS PAVEMENT DETAIL
N.T.S.

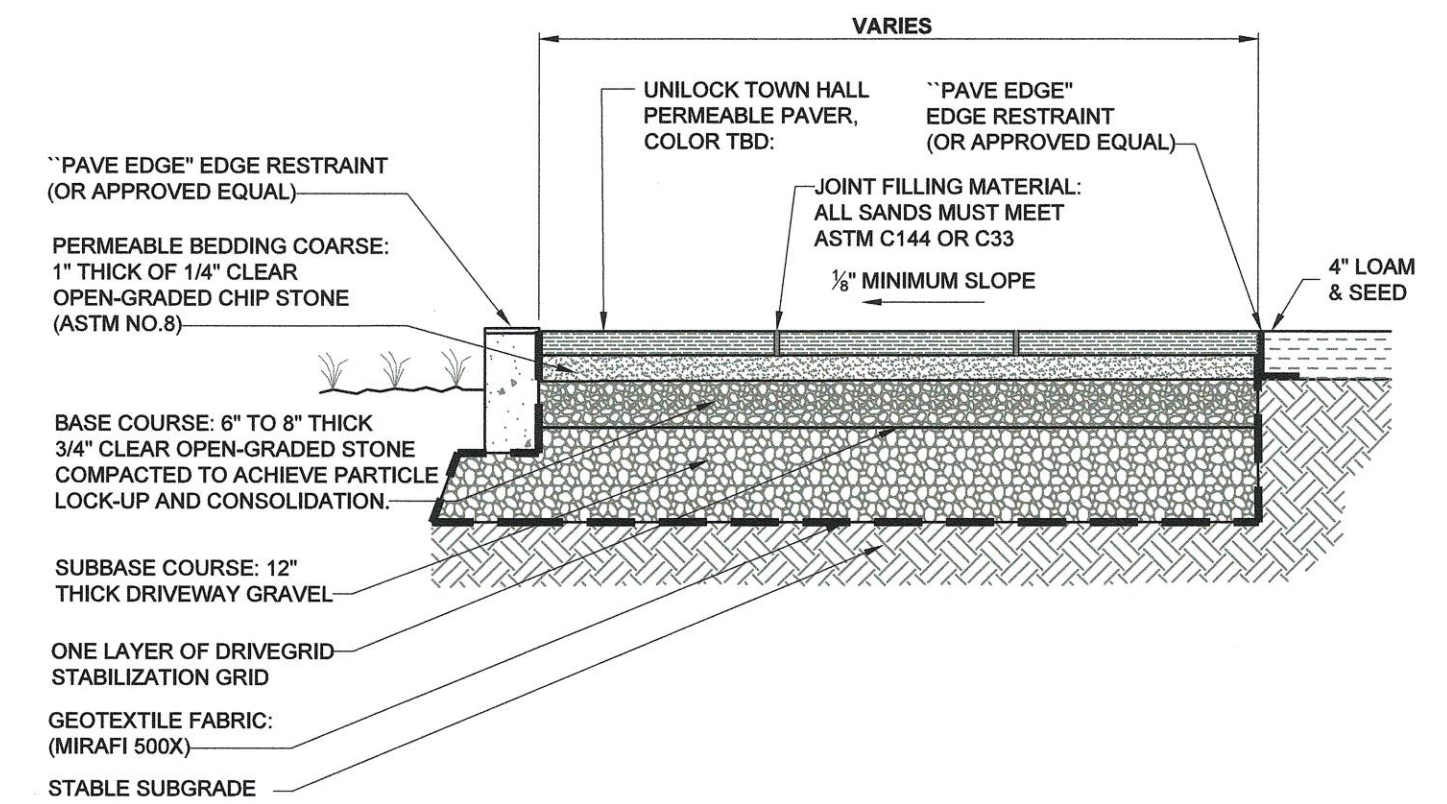

- NOTES:
- 1) UNLOCK (OR APPROVED EQUAL).
 - 2) INSTALLED PER MANUFACTURER'S INSTRUCTIONS.

UNLOCK PERVIOUS PAVER DETAIL
N.T.S.

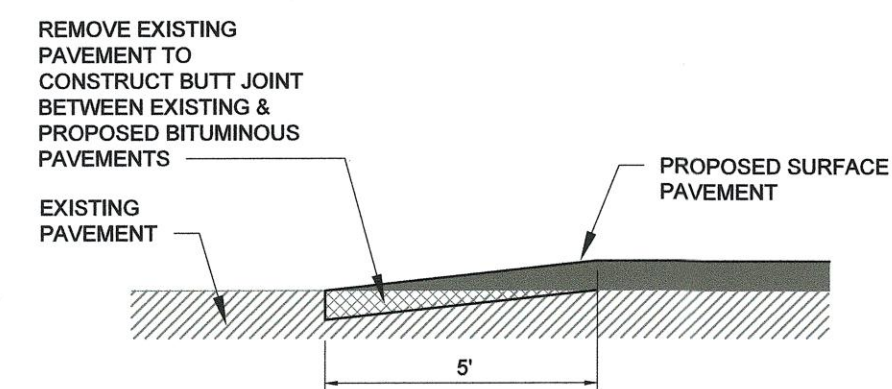

TYPICAL ASPHALT PAVEMENT BUTT JOINT DETAIL
N.T.S.

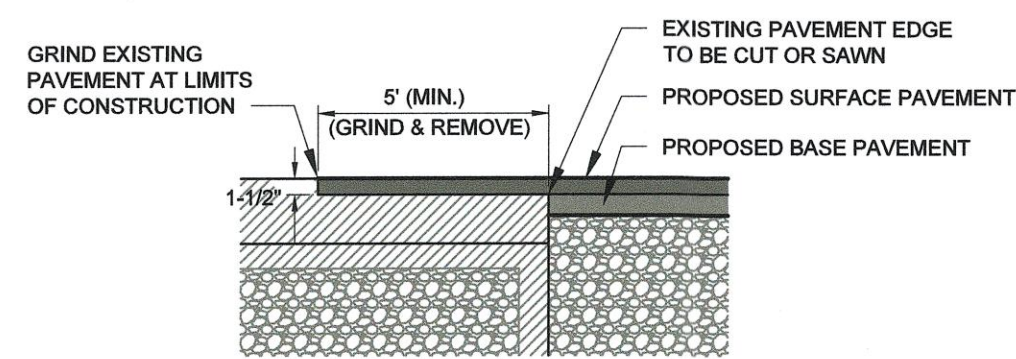

- NOTES:
1. EXTEND NEW SURFACE PAVEMENT ACROSS BUTT JOINT BASE COURSE.
 2. PROVIDE TACK COAT ON ALL SURFACES OF EXISTING PAVEMENT TO BE COVERED.

TYPICAL ASPHALT PAVEMENT GRINDING DETAIL
N.T.S.

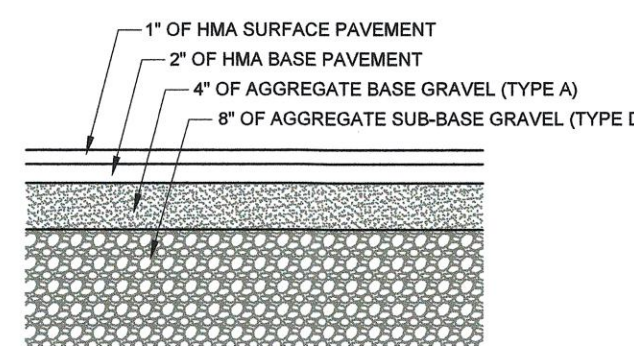

TYPICAL DRIVEWAY PAVING DETAIL
N.T.S.

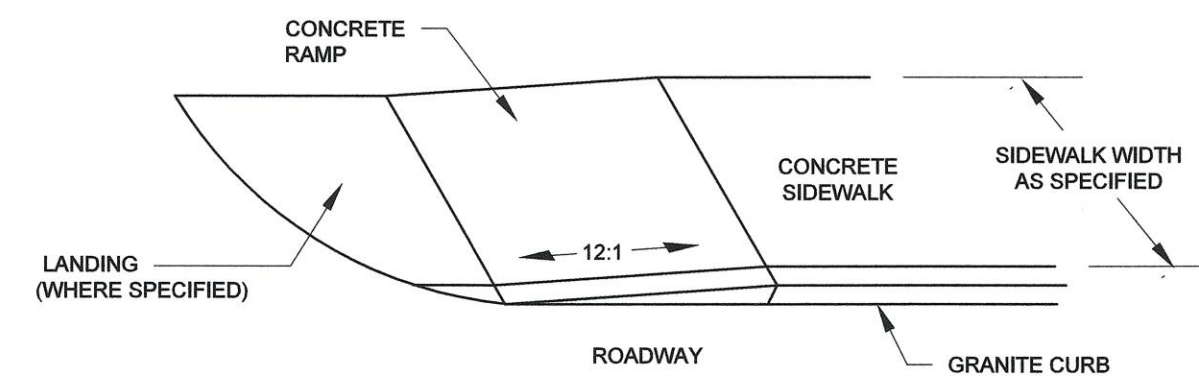

TYPICAL SIDEWALK TIP DOWNS
N.T.S. (NON INTERSECTION)

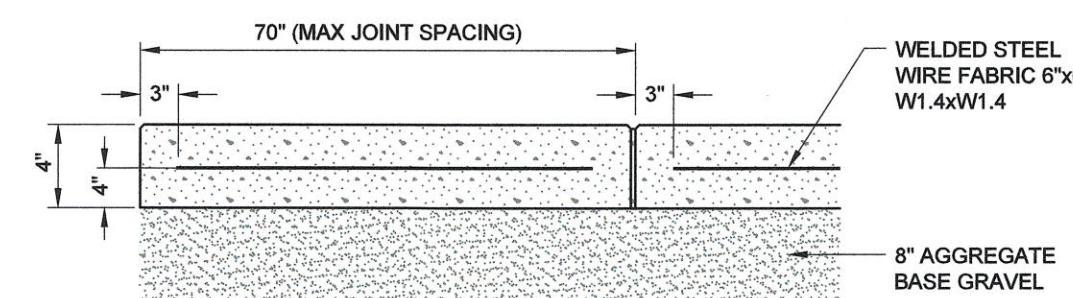

TYPICAL CONCRETE SIDEWALK DETAIL
N.T.S.

1	2026.02.13	ISSUED FOR COMMENT	JHV	SMT
REV.	DATE	DESCRIPTION	BY	CHK.
DRAWING ISSUE STATUS				
ISSUED FOR PERMITTING				
		200 Griffin Rd., Unit 14 Portsmouth, New Hampshire 03801 603.430.9282		
PROJECT				
PROPOSED 2 LOT SUBDIVISION RICHARDS AVE & SOUTH ST, PORTSMOUTH NH				
TITLE				
CONSTRUCTION DETAILS				
DATE		SCALE		
2026.02.13		NTS		
DRAWN BY	DESIGNED BY	CHECKED BY		
JHV	JHV	SMT		
PROJECT No.		5010220.003		
DRAWING No.		C502		
		2/15/26		
				1

FILE LOCATION: P:\MMS\0220-CHEMUR\BFILE\0220-00-00-CH-1.DWG, 2026.02.13, 10:57 AM

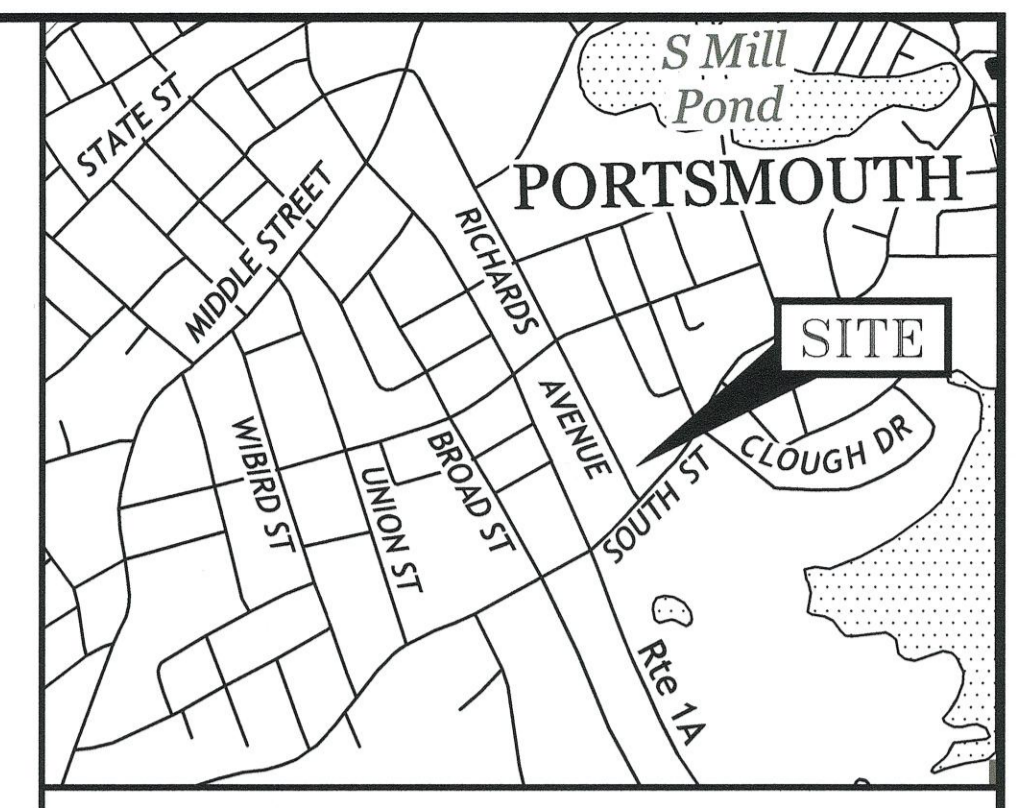
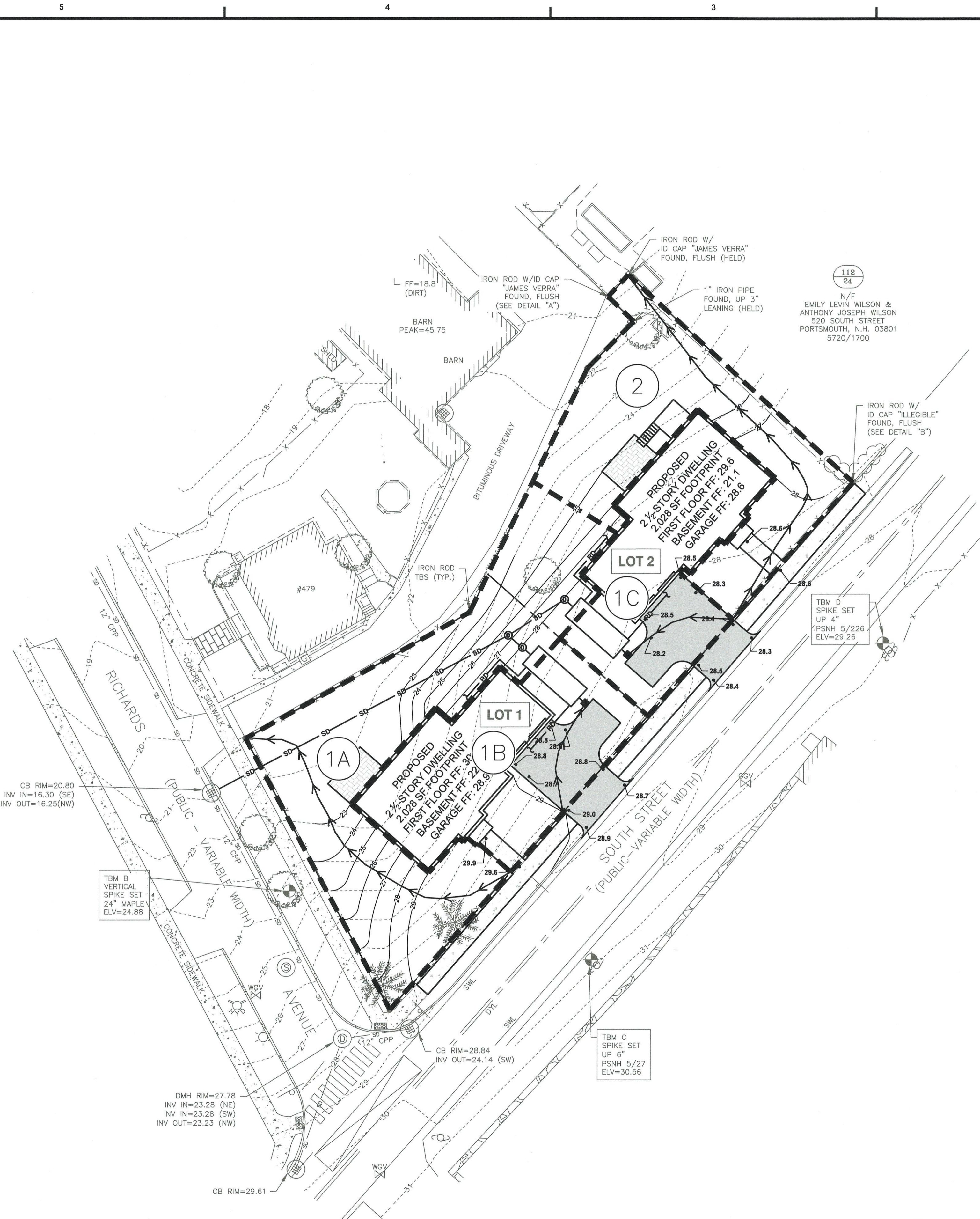

LOCATION MAP SCALE: 1" = 1,000'

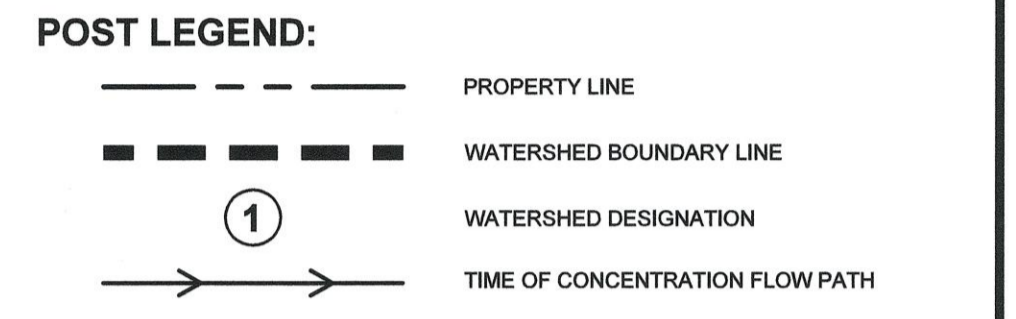

REV.	DATE	DESCRIPTION	BY	CHK
1	2026.02.13	ISSUED FOR COMMENT	JHV	SMT

ISSUED FOR REVIEW



PROJECT
PROPOSED 2 LOT SUBDIVISION
 RICHARDS AVE & SOUTH ST, PORTSMOUTH NH

TITLE
POST-DEVELOPMENT
HYDROLOGY PLAN

	DATE	2026.02.13	SCALE	1" = 20'
	DRAWN BY	JHV	DESIGNED BY	JHV
	CHECKED BY	SMT	PROJECT No.	5010220.003
	DRAWING No.	C702	REV.	1

