



200 Griffin Road, Unit 3, Portsmouth, NH 03801
Phone (603) 430-9282 Fax 436-2315

7 November 2023

Peter Stith, Chair, City of Portsmouth TAC
1 Junkins Avenue
Portsmouth, NH 03801

RE: Request for TAC Workshop Review at 569 Submarine Way, Museum Expansion

Dear Mr. Stith and TAC Members:

On behalf of the Portsmouth Submarine Memorial Association, we are pleased to submit the attached plan set for **TAC Workshop Review** for the above-mentioned project and request that we be placed on the agenda for your **November 14, 2023**, Meeting. The project is the proposed construction of an addition to the exiting Albacore Park Museum with the associated and required site improvements.

The following plans are included in our submission:

- Cover Sheet – This shows the Development Team, Legend, Site Location, and Abutters.
- Boundary Plan C1 – This plan shows the existing site property boundary and the existing site easements.
- Existing Conditions Plan – Orthophoto C2 – This plan shows the existing site detail based on photography from a drone flight.
- Existing Conditions Plan C3 - This plan shows the existing site in detail.
- Site Plan C4 – This plan shows the site development with the proposed addition and the circulation and layout with setbacks. The project received a Variance from the Board of Adjustment for the expansion of the museum use.
- Utility Plan C5 – This plan shows site utilities. The project will connect utilities internally, with a section of an existing water service being relocated to the same building entrance.
- Grading and Drainage Plan C6 – This plan shows the relocation of existing drainage at the proposed addition.
- Erosion Control Notes and Details D1 and Details D2 – These plans shows site details.
- Floor Plans and Elevations A1.1 and A 2.1 – This plan shows the Architectural design for the buildings.

We look forward to TAC review of this submission and the Committees feedback.

Sincerely,

John R. Chagnon, PE

PROPOSED MUSEUM BUILDING ALBACORE PARK 569 SUBMARINE WAY PORTSMOUTH, NEW HAMPSHIRE SITE PLANS

REQUIRED PERMITS:
PORTSMOUTH ZONING BOARD: APPROVED
PORTSMOUTH PLANNING BOARD: PENDING

LEGEND:

N/F	NOW OR FORMERLY	PROPERTY LINE
RP	RECORD OF PROBATE	SETBACK LINE
RCRD	ROCKINGHAM COUNTY	FORCE MAIN
	REGISTRY OF DEEDS	SEWER PIPE
(11/21)	MAP 11/LOT 21	SEWER LATERAL
● IR FND	IRON ROD FOUND	GAS LINE
○ IP FND	IRON PIPE FOUND	STORM DRAIN
● IR SET	IRON ROD SET	FOUNDATION DRAIN
○ DH FND	DRILL HOLE FOUND	WATER LINE
○ DH SET	DRILL HOLE SET	FIRE SERVICE LINE
■	GRANITE BOUND w/IRON ROD FOUND	UNDERGROUND ELECTRIC SUPPLY
---		UNDERGROUND ELECTRIC SERVICE
---		OVERHEAD ELECTRIC/WIRES
---		RETAINING WALL
---		EDGE OF PAVEMENT (EP)
100	100	CONTOUR
97x3	98x0	SPOT ELEVATION
⊕	⊕	UTILITY POLE
E	E	ELECTRIC METER
■	■	TRANSFORMER ON CONCRETE PAD
■	■	ELECTRIC HANDHOLD/PULLBOX
⊗	⊗	WATER SHUT OFF/CURB STOP
○ C.O.	○ C.O.	PIPE CLEANOUT
⊗	⊗	GATE VALVE
⊗	⊗	HYDRANT
⊗	⊗	CATCH BASIN
⊗	⊗	SEWER MANHOLE
⊗	⊗	DRAIN MANHOLE
⊗	⊗	WATER METER MANHOLE
⊗	⊗	TEST BORING
⊗	⊗	TEST PIT
LA	LA	LANDSCAPED AREA
CI	CI	CAST IRON PIPE
COP	COP	COPPER PIPE
CMP	CMP	CORRUGATED METAL PIPE
DI	DI	DUCTILE IRON PIPE
PVC	PVC	POLYVINYL CHLORIDE PIPE
RCP	RCP	REINFORCED CONCRETE PIPE
HYD	HYD	HYDRANT
℄	℄	CENTERLINE
EP	EP	EDGE OF PAVEMENT
EL	EL	ELEVATION
FF	FF	FINISHED FLOOR
INV	INV	INVERT
TBM	TBM	TEMPORARY BENCH MARK
TYP	TYP	TYPICAL
HH	HH	UTILITY HANDHOLE

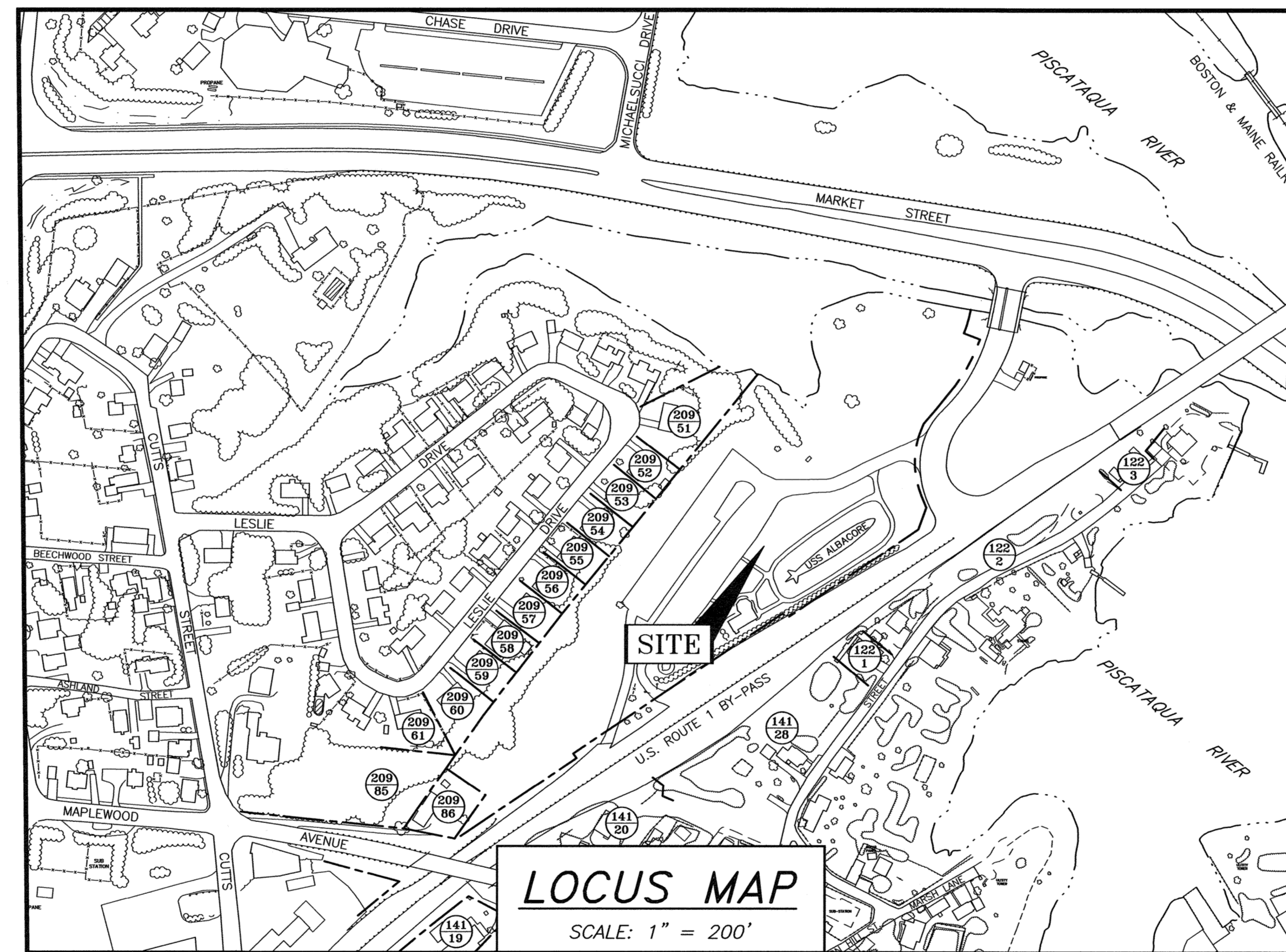

OWNER:
PORTSMOUTH SUBMARINE
MEMORIAL ASSOCIATION
569 SUBMARINE WAY
PORTSMOUTH, NH 03801
TEL: (603) 436-3680

LAND SURVEYOR & CIVIL ENGINEER:
AMBIT ENGINEERING
A DIVISION OF HALEY WARD, INC.
200 GRIFFIN ROAD, UNIT 3
PORTSMOUTH, NH 03801
(603) 430-9282

ARCHITECT:
PORT ONE ARCHITECTS
959 ISLINGTON STREET
PORTSMOUTH, NH. 03801
TEL: (603) 436-8891

LAND USE ATTORNEY:
HOEFLE, PHOENIX, GORMLEY &
ROBERTS, PLLC
127 PARROTT AVENUE
PORTSMOUTH, NH 03801
TEL. (603) 436-0666

INDEX OF SHEETS

- C1 - BOUNDARY PLAN
- C2 - EXISTING CONDITIONS ORTHOPHOTO
- C3 - EXISTING CONDITIONS PLAN
- C4 - SITE PLAN
- C5 - UTILITY PLAN
- C6 - GRADING & DRAINAGE PLAN
- D1-D2 - DETAILS
- - ARCHITECTURAL PLANS

UTILITY CONTACTS

ELECTRIC:
EVERSOURCE
1700 LAFAYETTE ROAD
PORTSMOUTH, N.H. 03801
Tel. (603) 436-7708, Ext. 555.5678
ATTN: MICHAEL BUSBY, P.E. (MANAGER)

NATURAL GAS:
UNITIL
325 WEST ROAD
PORTSMOUTH, N.H. 03801
Tel. (603) 294-5144
ATTN: DAVE BEAULIEU

CABLE:
XFINITY BY COMCAST
180 GREENLEAF AVE.
PORTSMOUTH, N.H. 03801
Tel. (603) 266-2278
ATTN: MIKE COLLINS

SEWER & WATER:
PORTSMOUTH DEPARTMENT
OF PUBLIC WORKS
680 PEVERLY HILL ROAD
PORTSMOUTH, N.H. 03801
Tel. (603) 427-1530
ATTN: JIM TOW

COMMUNICATIONS:
FAIRPOINT
COMMUNICATIONS
1575 GREENLAND ROAD
GREENLAND, N.H. 03840
Tel. (603) 427-5525
ATTN: JOE CONSIDINE
EMAIL:
jconsidine@fairpoint.com

PROJECT ABUTERS:

(141/19)	N/F 1010 US ROUTE 1 BYPASS, LLC 720 LAFAYETTE ROAD SEABROOK, NH 03874 5882/0945	(122/1)	N/F ANDREA L. ARDITO & BRAD R. LERO 121 NORTHWEST STREET PORTSMOUTH, NH 03801 5646/0912	(209/51)	N/F DONNA J. FLAGG LIVING TRUST DONNA J. FLAGG, TRUSTEE 920 SE 46TH STREET APT. 2A CAPE CORAL, FL 33904 4235/1400	(209/54)	N/F JAMES J. & CARLA J. MURPHY REV TRUST JAMES J. & CARLA J. MURPHY TRUSTEES 214 LESLIE DRIVE PORTSMOUTH, N.H. 03801 5967/2916	(209/57)	N/F GERALD R. & DOLORES BROWN IRREVOCABLE TRUST GERALD R. & DOLORES BROWN TRUSTEES 174 LESLIE DRIVE PORTSMOUTH, N.H. 03801 4860/0981	(209/60)	N/F JEFFREY J. & KELLY L. MEE 130 LESLIE DRIVE PORTSMOUTH, N.H. 03801 6084/1599	(209/86)	N/F STATE OF NEW HAMPSHIRE P.O. BOX 483, 7 HAZEN DRIVE CONCORD, N.H. 03302 5014/1442
(141/20)	N/F ALLAN I. PECHNER 399 MAPLEWOOD AVENUE #3 PORTSMOUTH, N.H. 03801 5573/1754	(122/2)	N/F AMANDA B. MORNEAULT 137 NORTHWEST STREET PORTSMOUTH, N.H. 03801 6479/2400	(209/52)	N/F MATTHEW C. BEAL & HEIDI L. MEDLYN 242 LESLIE DRIVE PORTSMOUTH, N.H. 03801 5766/2758	(209/55)	N/F SAMANTHA SMART & DEREK SWEITZER 202 LESLIE DRIVE PORTSMOUTH, N.H. 03801 6452/2890	(209/58)	N/F WILLIAM & MARTHA BOULANGER 354 POST ROAD GREENLAND, N.H. 03840 4614/0005	(209/61)	N/F JEANE CLEMENTS 122 LESLIE DRIVE PORTSMOUTH, N.H. 03801 5313/1380	(122/2-1)	N/F DAR BUILDERS LLC 305 MASSABESIC STREET MANCHESTER, N.H. 03103 6397/0611
(141/28)	N/F JULIANN C. LEHNE & WILLIAM A. LEHNE JR. 73 NORTHWEST STREET PORTSMOUTH, N.H. 03801 6198/2447	(122/3)	N/F MICHAEL GEORGE PETRIN KATIE MARIE LAVERRIERE 239 NORTHWEST STREET PORTSMOUTH, N.H. 03801 2304/1890	(209/53)	N/F JOSEPH F. & ROSE M. CALDERARA 230 LESLIE DRIVE PORTSMOUTH, N.H. 03801 2320/1967	(209/56)	N/F PAMELA EIFFE 186 LESLIE DRIVE PORTSMOUTH, N.H. 03801 6098/2784	(209/59)	N/F JEFFREY J. MEE & KELLEY L. MICHAUD MEE TRUST JEFFREY J. MEE & KELLY L. MEE TRUSTEES 146 LESLIE DRIVE PORTSMOUTH, N.H. 03801 6497/2676	(209/85)	N/F CUTTS MANSION CONDOMINIUM 525 MAPLEWOOD AVENUE PORTSMOUTH, N.H. 03801 5549/413 D-38356	(122/4-2)	N/F BRIAN BLANCHETTE 250B NORTHWEST STREET PORTSMOUTH, N.H. 03801 4298/2699
		(122/4)	N/F CHRISTIAN SHORE CONDOMINIUM 250 NORTHWEST STREET PORTSMOUTH, NH 03801										

APPROVED BY THE PORTSMOUTH PLANNING BOARD

CHAIRMAN _____ DATE _____

**PROPOSED MUSEUM BUILDING
ALBACORE PARK
569 SUBMARINE WAY
PORTSMOUTH, N.H.**



200 Griffin Road, Unit 3
Portsmouth, NH 03801
603.430.9282
WWW.HALEYWARD.COM
PLAN SET SUBMITTAL DATE: 7 NOVEMBER 2023

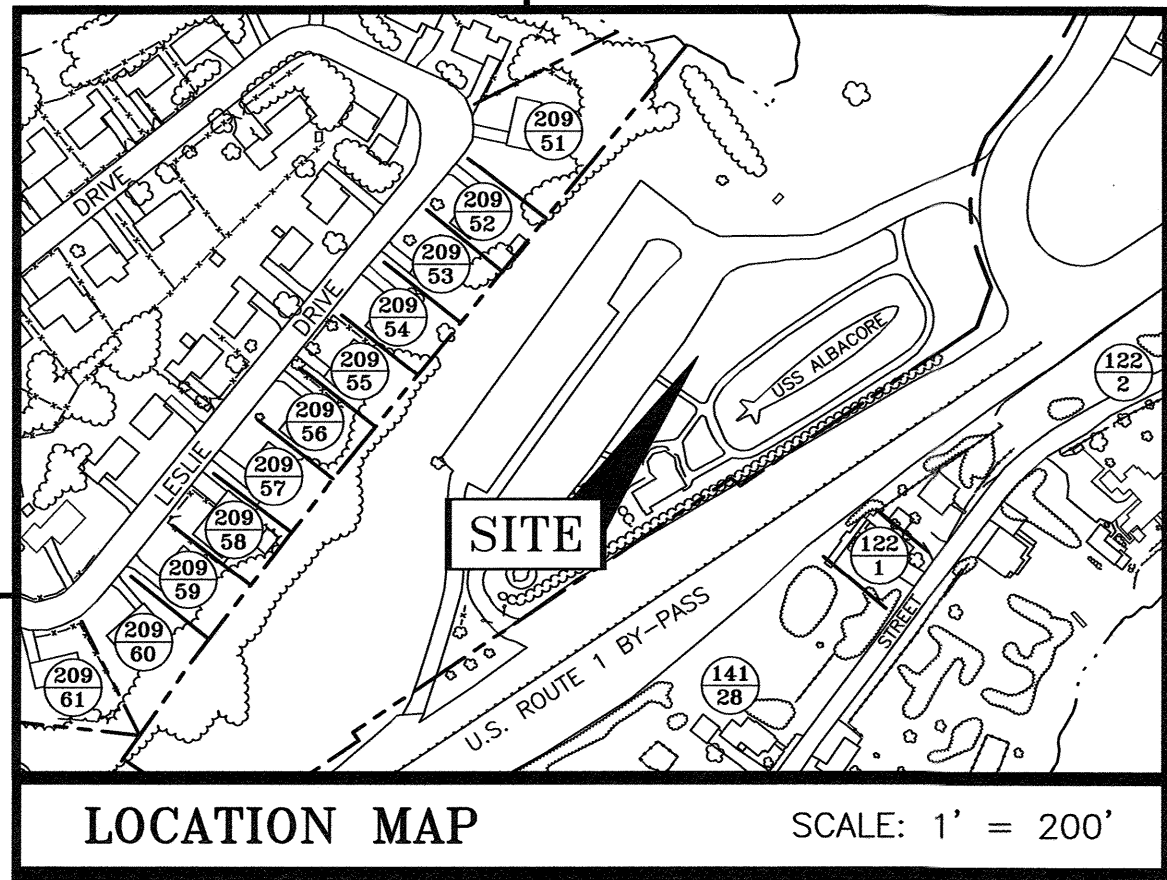

PLAN REFERENCES:

- 1) LAND OF INTERSTATE BRIDGE AUTHORITY FOR ALBACORE MEMORIAL PARK ROUTE 1-BYPASS PORTSMOUTH, NH. PREPARED BY: RICHARD P MILLETTE AND ASSOCIATES, SCALE: 1"=60', DATED: 11/16/84. RCRD D-13159.
- 2) STATE OF NEW HAMPSHIRE DEPARTMENT OF TRANSPORTATION RIGHT-OF-WAY PLANS X-5379(025) NH PROJECT NO. 13455 US ROUTE 1 BYPASS OVER PISCATAQUA RIVER BRIDGE NO. 251/108. PREPARED BY: GM2 ASSOCIATES, SCALE: 1"=20', DATED: JULY 17, 2019. RCRD D-41603.
- 3) EASEMENT PLAN FOR MUDFLAT & SALTMARSH MITIGATION SITES ALONG INNER INNER CUTTS COVE ADJACENT TO MARKET STREET EXTENSION PORTSMOUTH, NH. PREPARED BY: KIMBALL CHASE FOR BALSAM ENVIRONMENTAL CONSULTANTS, INC., DATED: APRIL, 1994, SCALE: 1"=60'. NOT RECORDED.
- 4) SITE PLAN PLAN FOR MUDFLAT & SALTMARSH MITIGATION SITES ALONG INNER INNER CUTTS COVE ADJACENT TO MARKET STREET EXTENSION PORTSMOUTH, NH. PREPARED BY: KIMBALL CHASE FOR NEW HAMPSHIRE PORT AUTHORITY, DATED: APRIL 14, 1994, SCALE: 1"=60'. NOT RECORDED.
- 5) PLAN OF BERSUM GARDENS FOR MARGO CONST. CO. PORTSMOUTH, NH. PREPARED BY: JOHN W DURGIN CIVIL ENGINEERS, SCALE: 1"=100', DATED: OCTOBER 1955. RCRD #02178.
- 6) CONDOMINIUM SITE PLAN "THE CUTTS MANSION CONDOMINIUM 525 MAPLEWOOD AVENUE PORTSMOUTH, NH FOR NEW ENGLAND GLORY, LLC. PREPARED BY: JAMES VERRA AND ASSOCIATES, SCALE: 1"=20', DATED: 6-30-2014. RCRD D-38356.
- 7) PORTSMOUTH POWER COMPANY POWER TRANSMISSION LINE ACROSS LAND OF RICHARD H HAM PORTSMOUTH, NH. SCALE: 1"=200', DATED: MARCH 21, 1924. RCRD #0353.
- 8) CITY OF PORTSMOUTH, NH BOARD OF PUBLIC WORKS LAYOUT OF PROPOSED SEWER ON PROPERTY OF R.H. HAM MAPLEWOOD AVENUE. PREPARED BY: JOHN W DURGIN, SCALE: 1"=200', DATED: FEBRUARY 1929. RCRD #0738.
- 9) WATER EASEMENT PLAN ACROSS LAND OF ALBACORE TRUST LESLIE DRIVE COUNTY OF ROCKINGHAM PORTSMOUTH, NH. PREPARED BY: RICHARD P MILLETTE AND ASSOCIATES, SCALE: 1"=10', DATED: JULY 26, 1984. RCRD C-12849.
- 10) EASEMENT PLAN PORT OF PORTSMOUTH MARITIME MUSEUM ASSOCIATION & PUBLIC SERVICE OF NEW HAMPSHIRE ALBACORE PARK PORTSMOUTH, NH. PREPARED BY: WILLIAM T WORMELL, SCALE: 1"=50', DATED: 11/2/05. RCRD C-33208.
- 11) NEW HAMPSHIRE GAS & ELECTRIC COMPANY PLAN SHOWING REROUTING OF TRANSMISSION LINE ROUTE 1503 FROM JACKSON HILL SUB STATION THROUGH POLE T21-5038 SHOWING RIGHT OF WAY CHANGES. SCALE: 1"=40', DATED: 12-9-1939, PLAN Y368A. RCRD #03429.
- 12) ME NH INTERSTATE BRIDGE AUTHORITY NEW HAMPSHIRE APPROACH RIGHT OF WAY PLANS. PREPARED BY: JOHN W DURGIN CIVIL ENGINEERS, DATED: APRIL 1955. RCRD #02539.

INNER INNER CUTTS COVE

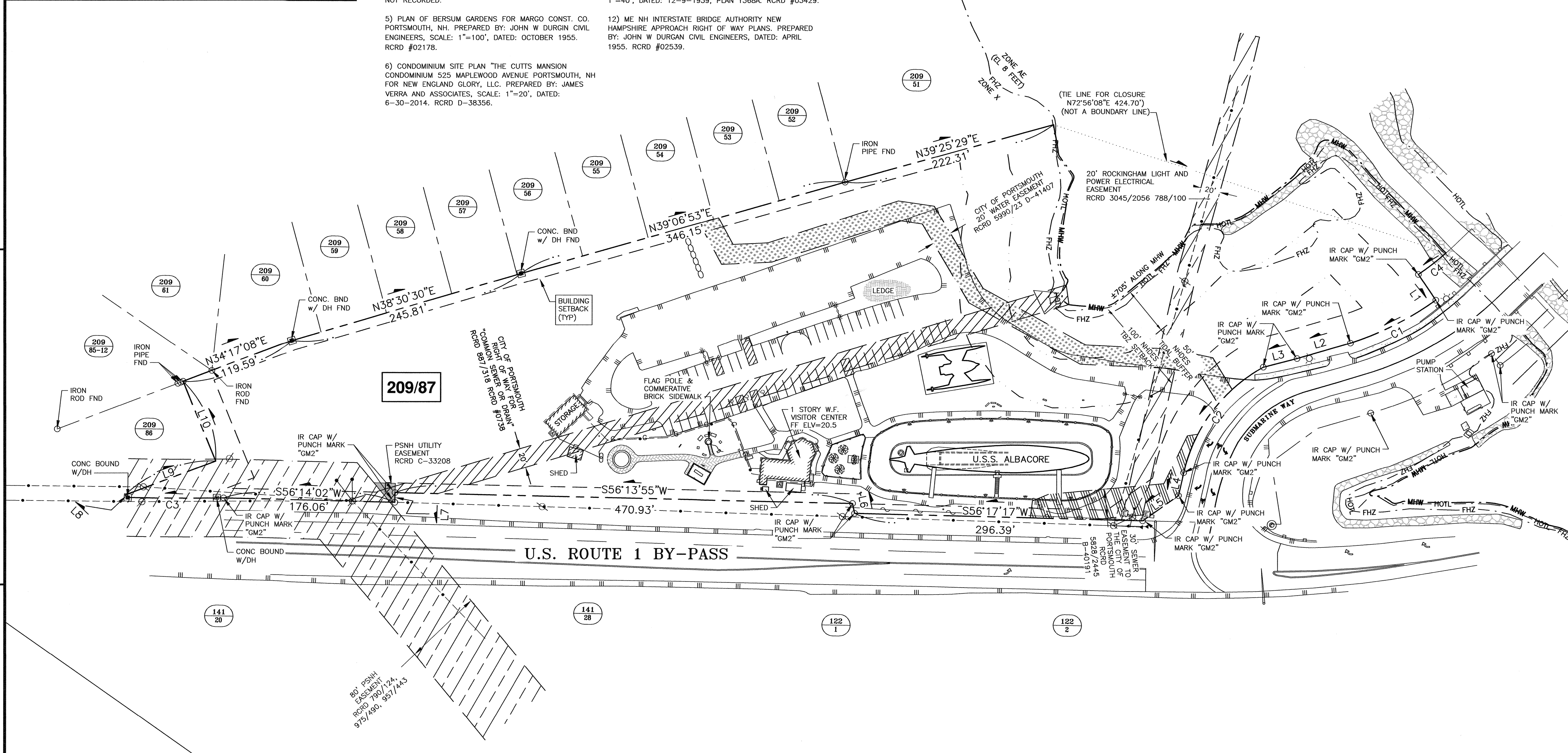

NOTES:

- 1) PARCEL IS SHOWN ON THE CITY OF PORTSMOUTH ASSESSOR'S MAP 209 AS LOT 87.
- 2) OWNERS OF RECORD: PORTSMOUTH SUBMARINE MEMORIAL ASSOCIATION 569 SUBMARINE WAY PORTSMOUTH, N.H. 03801 2532/1623, 5551/1278
- 3) PARCEL IS PARTIALLY IN SPECIAL FLOOD HAZARD AREA (AE EL. 8) AS SHOWN ON FIRM PANEL 33015C0259F. DATED JANUARY 29, 2021.
- 4) EXISTING LOT AREA: 302,176 S.F.± 6,9370 AC.± 705'± ALONG MEAN HIGH WATER
- 5) PARCEL IS LOCATED IN SINGLE RESIDENCE B DISTRICT.
- 6) DIMENSIONAL REQUIREMENTS:
MIN. LOT AREA: 15,000 S.F.
FRONTAGE: 100 FEET
SETBACKS: FRONT 30 FEET
SIDE 30 FEET
REAR 30 FEET
MAXIMUM STRUCTURE HEIGHT: 35 FEET
MAXIMUM BUILDING COVERAGE: 20%
MINIMUM OPEN SPACE: 40%
- 7) THE PURPOSE OF THIS PLAN IS TO SHOW THE RESULTS OF A STANDARD BOUNDARY SURVEY OF ASSESSOR'S MAP 209 LOT 87 IN THE CITY OF PORTSMOUTH.
- 8) VERTICAL DATUM IS NAVD88. BASIS OF VERTICAL DATUM IS REDUNDANT GNSS OBSERVATIONS.
- 9) MEAN HIGH WATER SHOWN AT ELEVATION 3.81' (NAVD88) PER NOAA STATION 8419870 SEAVY ISLAND, PORTSMOUTH HARBOR TIDAL DATUM.
- 10) PARCEL IS BURDENED BY AN 80' WIDE UTILITY EASEMENT TO PUBLIC SERVICE OF NEW HAMPSHIRE, SEE RCRD 790/124, 975/490, 957/443.
- 11) PARCEL IS BURDENED BY A PUBLIC SERVICE UTILITY EASEMENT "A" SEE RCRD C-33208.
- 12) PARCEL IS BURDENED BY A 30' SEWER EASEMENT TO THE CITY OF PORTSMOUTH, SEE RCRD 5828/2445 AND RCRD B-40191.
- 13) PARCEL IS BURDENED BY A 20' WATER EASEMENT TO THE CITY OF PORTSMOUTH, SEE RCRD 5990/23 AND RCRD D-41407.
- 14) PARCEL IS BURDENED BY A RIGHT OF WAY FOR COMMON SEWER OR DRAIN TO THE CITY OF PORTSMOUTH, SEE RCRD 887/318 AND RCRD #0738.
- 15) PARCEL IS BURDENED BY A 20' POWER AND ELECTRIC EASEMENT TO ROCKINGHAM LIGHT AND POWER, SEE RCRD 3045/2056 AND 788/100.

No.	DATE	ISSUED FOR COMMENT	RJB	JRC
0	11/7/23			

DRAWING ISSUE STATUS
TAC SUBMISSION



200 Griffin Road, Unit 3
Portsmouth, NH 03801
603.430.9282
WWW.HALEYWARD.COM

ALBACORE PARK BUILDING ADDITION
569 SUBMARINE WAY PORTSMOUTH, NEW HAMPSHIRE

BOUNDARY PLAN

"I CERTIFY THAT THIS PLAN WAS PREPARED UNDER MY DIRECT SUPERVISION, THAT IT IS THE RESULT OF A FIELD SURVEY BY THIS OFFICE AND HAS AN ACCURACY OF THE CLOSED TRAVERSE THAT EXCEEDS THE PRECISION OF 1:15,000."

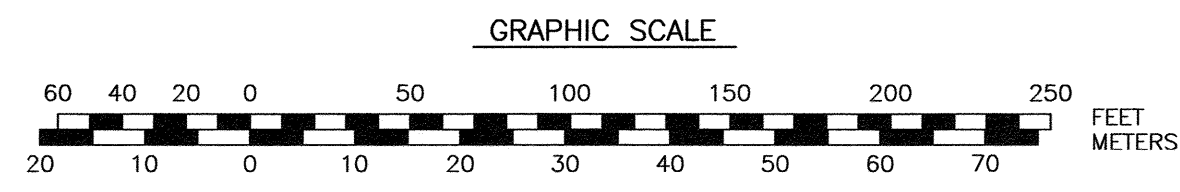

CURVE TABLE:

CURVE	RADIUS	ARC LENGTH	CHORD LENGTH	CHORD BEARING	DELTA ANGLE
C1	325.00'	98.66'	98.28'	S28°00'59"W	17°23'37"
C2	165.00'	140.18'	136.01'	S01°51'33"W	48°40'43"
C3	2915.00'	98.67'	98.66'	S55°13'39"W	1°56'22"
C4	280.00'	36.07'	36.05'	S17°02'20"W	7°22'52"

LINE TABLE:

LINE	BEARING	DISTANCE
L1	S69°16'14"E	32.00'
L2	S38°45'23"W	57.13'
L3	S40°26'15"W	35.88'
L4	S22°28'48"E	24.15'
L5	S19°49'28"W	45.11'
L6	N46°29'25"W	10.31'
L7	S33°36'34"E	10.00'
L8	N82°03'04"W	3.84'
L9	N34°27'30"E	99.58'
L10	N57°20'18"W	88.89'

JOHN R. CHAGNON, LLS 738 DATE

DATE: OCTOBER 2023 SCALE: 1" = 60'

DRAWN BY: RJB DESIGNED BY: JRC CHECKED BY: JRC

PROJECT No.: 5010373-452.02 FIELD BOOK & PAGE: FB 347 PG 20

SHEET No.: SHEET 1 DWG No.: C1

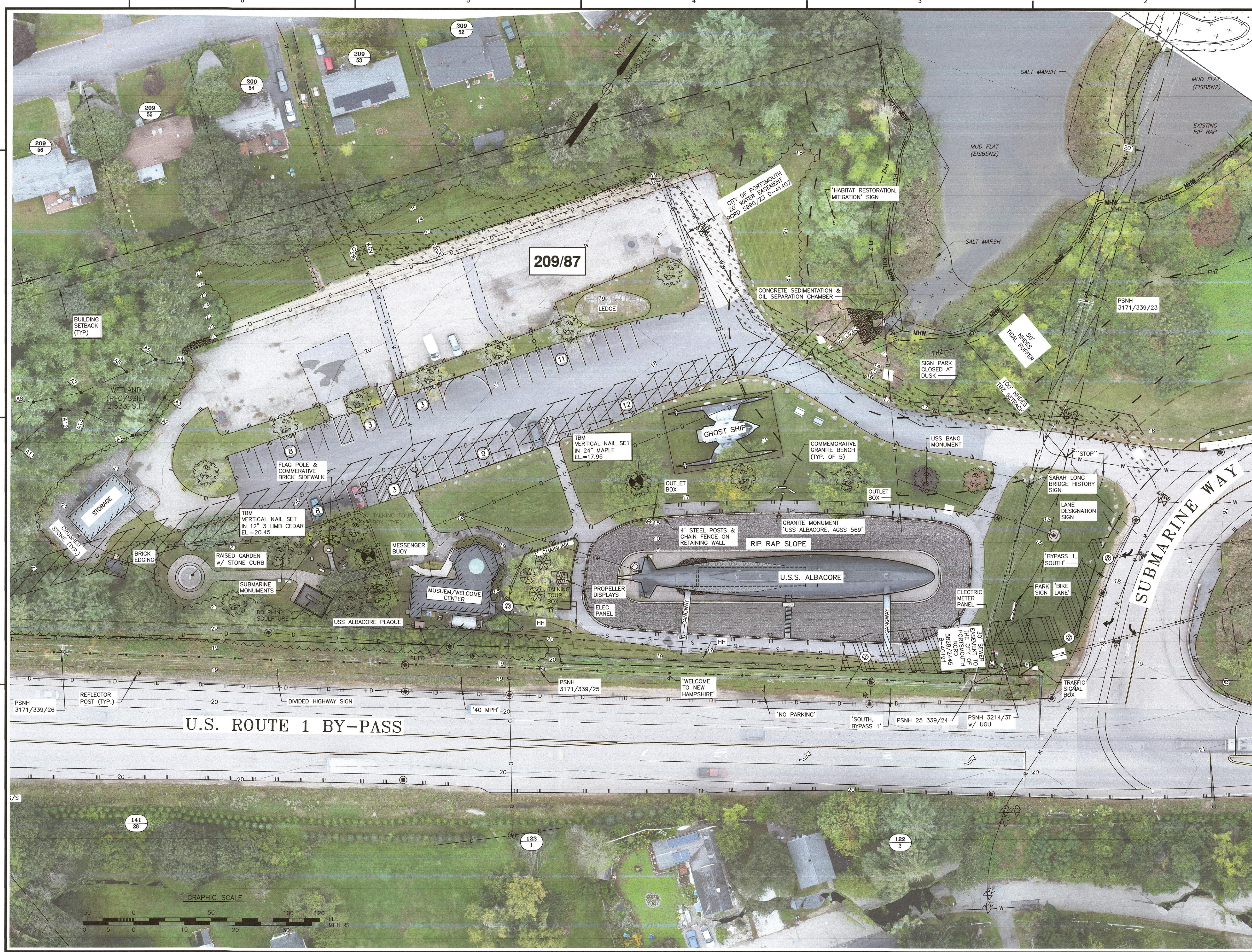

- NOTES:**
- 1) PARCEL IS SHOWN ON THE CITY OF PORTSMOUTH ASSESSOR'S MAP 209 AS LOT 87.
 - 2) OWNERS OF RECORD:
PORTSMOUTH SUBMARINE MEMORIAL ASSOCIATION
569 SUBMARINE WAY
PORTSMOUTH, N.H. 03801
2532/1623, 5551/1278
 - 3) PARCEL IS PARTIALLY IN SPECIAL FLOOD HAZARD AREA (AE) AS SHOWN ON FIRM PANEL 33015C0259F, DATED JANUARY 29, 2021.
 - 4) EXISTING LOT AREA:
302,176 S.F.±
6.9370 AC.±
 - 5) PARCEL IS LOCATED IN SINGLE RESIDENCE B DISTRICT.
 - 6) DIMENSIONAL REQUIREMENTS:
MIN. LOT AREA: 15,000 S.F.
FRONTAGE: 100 FEET
SETBACKS: FRONT 30 FEET
SIDE 10 FEET
REAR 30 FEET
MAXIMUM STRUCTURE HEIGHT: 35 FEET
MAXIMUM BUILDING COVERAGE: 20%
MINIMUM OPEN SPACE: 40%
 - 7) VERTICAL DATUM IS NAVD88. BASIS OF VERTICAL DATUM IS REDUNDANT GNSS OBSERVATIONS.
 - 8) MEAN HIGH WATER SHOW AT ELEVATION 3.81' (NAVD88) PER NOAA STATION 8419870 SEAVY ISLAND, PORTSMOUTH HARBOR TIDAL DATUM.
 - 9) THE PURPOSE OF THIS PLAN IS TO SHOW THE EXISTING CONDITIONS ON ASSESSOR'S TAX MAP 209 LOT 87 IN THE CITY OF PORTSMOUTH.

0	11/7/23	ISSUED FOR COMMENT	RJB	JRC
No.	DATE	DESCRIPTION	BY	CHK.

DRAWING ISSUE STATUS

TAC SUBMISSION

AMBIT ENGINEERING, INC.
A DIVISION OF HALEY WARD, INC.

200 Griffin Road, Unit 3
Portsmouth, NH 03801
603.430.9282

PROJECT

ALBACORE PARK BUILDING ADDITION
569 SUBMARINE WAY PORTSMOUTH, NEW HAMPSHIRE

TITLE

EXISTING CONDITIONS PLAN
ORTHOPHOTO

DATE	SCALE	
OCTOBER 2023	SCALE: 1" = 30'	
DRAWN BY	DESIGNED BY	CHECKED BY
RJB	---	JRC
PROJECT No.	FIELD BOOK & PAGE	
5010373-452.02	FB 347 PG 20	
SHEET No.	DWG No.	
SHEET 2	C2	

P:\NH\5010373-Portsmouth_Submarine_Memorial_Assn\452.02-1_Submarine_Way_Portsmouth-RJC\2023_Site_Plan\Plans & Specs\Site\452.02_Survey_2023.dwg, 11/6/2023 11:55:48 AM.
 Portsmouth Plotted: Canon TX3000.pcl

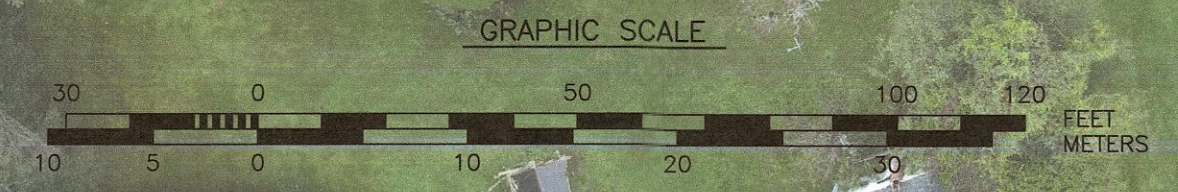

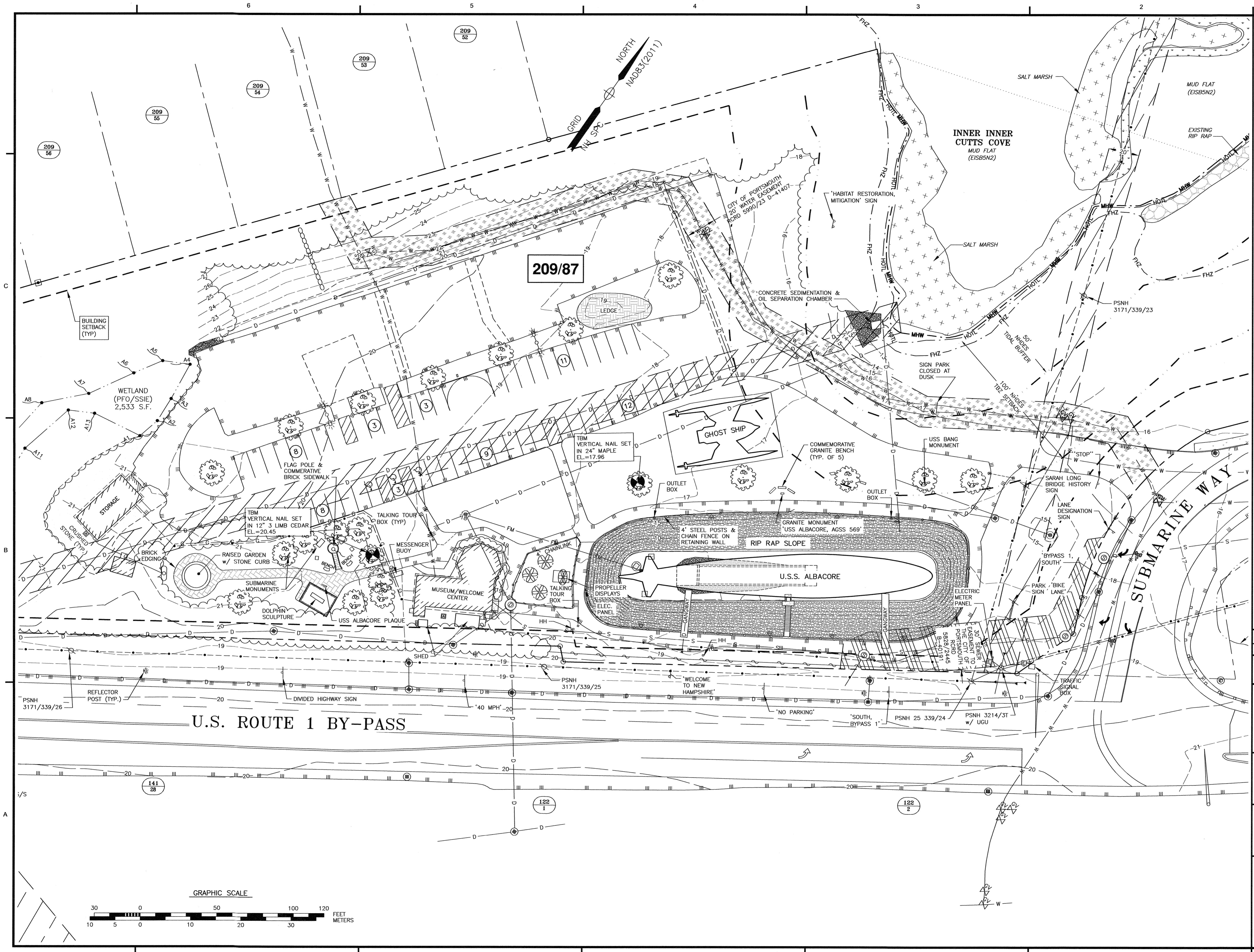

- NOTES:**
- 1) PARCEL IS SHOWN ON THE CITY OF PORTSMOUTH ASSESSOR'S MAP 209 AS LOT 87.
 - 2) OWNERS OF RECORD:
PORTSMOUTH SUBMARINE MEMORIAL ASSOCIATION
569 SUBMARINE WAY
PORTSMOUTH, N.H. 03801
2532/1623, 5551/1278
 - 3) PARCEL IS PARTIALLY IN SPECIAL FLOOD HAZARD AREA (AE) AS SHOWN ON FIRM PANEL 33015C0259F. DATED JANUARY 29, 2021.
 - 4) EXISTING LOT AREA:
302,176 S.F.±
6.9370 AC.±
 - 5) PARCEL IS LOCATED IN SINGLE RESIDENCE B DISTRICT.
 - 6) DIMENSIONAL REQUIREMENTS:
MIN. LOT AREA: 15,000 S.F.
FRONTAGE: 100 FEET
SETBACKS: FRONT 30 FEET
SIDE 10 FEET
REAR 30 FEET
MAXIMUM STRUCTURE HEIGHT: 35 FEET
MAXIMUM BUILDING COVERAGE: 20%
MINIMUM OPEN SPACE: 40%
 - 7) VERTICAL DATUM IS NAVD88. BASIS OF VERTICAL DATUM IS REDUNDANT GNSS OBSERVATIONS.
 - 8) MEAN HIGH WATER SHOW AT ELEVATION 3.81' (NAVD88) PER NOAA STATION 8419870 SEAVY ISLAND, PORTSMOUTH HARBOR TIDAL DATUM.
 - 9) THE PURPOSE OF THIS PLAN IS TO SHOW THE EXISTING CONDITIONS ON ASSESSOR'S TAX MAP 209 LOT 87 IN THE CITY OF PORTSMOUTH.

0	11/7/23	ISSUED FOR COMMENT	RJB	JRC
No.	DATE	DESCRIPTION	BY	CHK.

DRAWING ISSUE STATUS
TAC SUBMISSION

AMBIT ENGINEERING, INC.
A DIVISION OF HALEY WARD, INC.

200 Griffin Road, Unit 3
Portsmouth, NH 03801
603.430.9282

WWW.HALEYWARD.COM
PROJECT
ALBACORE PARK BUILDING ADDITION
569 SUBMARINE WAY PORTSMOUTH, NEW HAMPSHIRE

TITLE
EXISTING CONDITIONS PLAN

	DATE	OCTOBER 2023	SCALE	SCALE: 1" = 30'
	DRAWN BY	RJB	DESIGNED BY	—
	CHECKED BY	JRC	PROJECT No.	5010373-452.02
	FIELD BOOK & PAGE	FB 347 PG 20	DWG No.	—
SHEET 3		C3		

P:\NH\5010373-Portsmouth_Submarine_Memorial_Assn\452.02-1_Submarine_Way_Portsmouth-NH\452.02_Survey_2023.dwg, 11/7/2023, 2:00:29 PM.
 Portsmouth Ploter Color TX3000.pc3

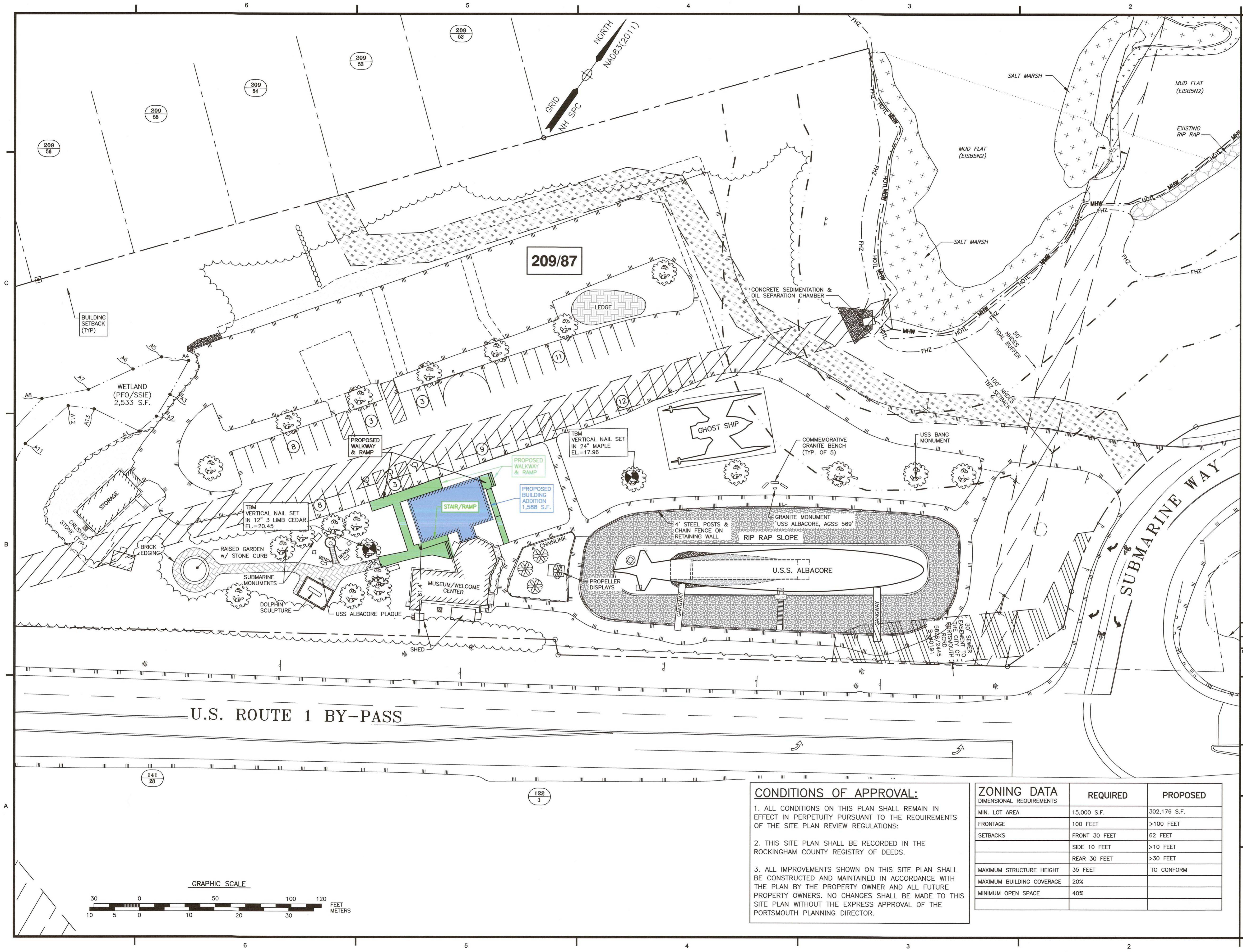

- NOTES:**
- 1) PARCEL IS SHOWN ON THE CITY OF PORTSMOUTH ASSESSOR'S MAP 209 AS LOT 87.
 - 2) OWNERS OF RECORD:
PORTSMOUTH SUBMARINE MEMORIAL ASSOCIATION
569 SUBMARINE WAY
PORTSMOUTH, N.H. 03801
2532/1623, 5551/1278
 - 3) PARCEL IS PARTIALLY IN SPECIAL FLOOD HAZARD AREA (AE) AS SHOWN ON FIRM PANEL 33015C0259F, DATED JANUARY 29, 2021.
 - 4) EXISTING LOT AREA:
302,176 S.F.±
6.9370 AC.±
 - 5) PARCEL IS LOCATED IN SINGLE RESIDENCE B DISTRICT.
 - 6) DIMENSIONAL REQUIREMENTS:
MIN. LOT AREA: 15,000 S.F.
FRONTAGE: 100 FEET
SETBACKS: FRONT 30 FEET
SIDE 10 FEET
REAR 30 FEET
MAXIMUM STRUCTURE HEIGHT: 35 FEET
MAXIMUM BUILDING COVERAGE: 20%
MINIMUM OPEN SPACE: 40%
 - 7) THE PURPOSE OF THIS PLAN IS TO SHOW THE PROPOSED MUSEUM BUILDING ADDITION ON ASSESSOR'S TAX MAP 209 LOT 87 IN THE CITY OF PORTSMOUTH.

0	11/7/23	ISSUED FOR COMMENT	OMS	JRC
No.	DATE	DESCRIPTION	BY	CHK.

DRAWING ISSUE STATUS
TAC SUBMISSION

AMBIT ENGINEERING, INC.
A DIVISION OF HALEY WARD, INC.

200 Griffin Road, Unit 3
Portsmouth, NH 03801
603-430-9282

WWW.HALEYWARD.COM

PROJECT
ALBACORE PARK BUILDING ADDITION
569 SUBMARINE WAY PORTSMOUTH, NEW HAMPSHIRE

TITLE
SITE PLAN

DATE	OCTOBER 2023	SCALE	SCALE: 1" = 30'
DRAWN BY	OMS	DESIGNED BY	JRC
CHECKED BY	JRC	CHECKED BY	JRC
PROJECT No.	5010373-452.02	FIELD BOOK & PAGE	FB 347 PG 20
SHEET No.		DWG No.	



CONDITIONS OF APPROVAL:

1. ALL CONDITIONS ON THIS PLAN SHALL REMAIN IN EFFECT IN PERPETUITY PURSUANT TO THE REQUIREMENTS OF THE SITE PLAN REVIEW REGULATIONS.
2. THIS SITE PLAN SHALL BE RECORDED IN THE ROCKINGHAM COUNTY REGISTRY OF DEEDS.
3. ALL IMPROVEMENTS SHOWN ON THIS SITE PLAN SHALL BE CONSTRUCTED AND MAINTAINED IN ACCORDANCE WITH THE PLAN BY THE PROPERTY OWNER AND ALL FUTURE PROPERTY OWNERS. NO CHANGES SHALL BE MADE TO THIS SITE PLAN WITHOUT THE EXPRESS APPROVAL OF THE PORTSMOUTH PLANNING DIRECTOR.

ZONING DATA DIMENSIONAL REQUIREMENTS	REQUIRED	PROPOSED
MIN. LOT AREA	15,000 S.F.	302,176 S.F.
FRONTAGE	100 FEET	>100 FEET
SETBACKS	FRONT 30 FEET	62 FEET
	SIDE 10 FEET	>10 FEET
	REAR 30 FEET	>30 FEET
MAXIMUM STRUCTURE HEIGHT	35 FEET	TO CONFORM
MAXIMUM BUILDING COVERAGE	20%	
MINIMUM OPEN SPACE	40%	

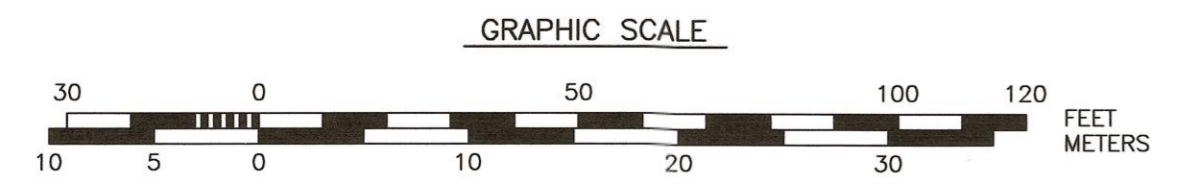

P:\NH\10173-Portsmouth-Submarine_Memorial_Assn\432.02-1-Submarine_Way_Portsmouth-IRC\2023_Site_Plan\Plans & Specs\Site\432.02 Survey 2023.dwg, 11/7/2023 1:34:50 PM.
 Portsmouth Planner: Chori TX3000.dwg

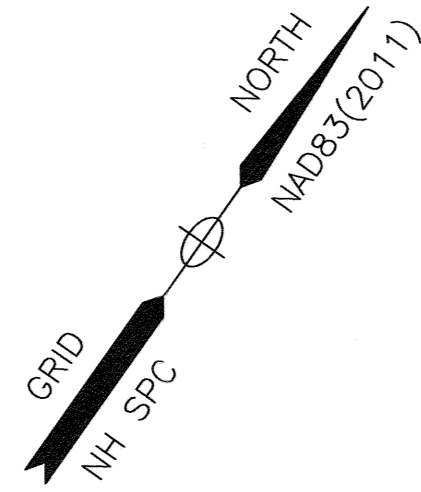

UTILITY NOTES:

- 1) SEE EXISTING CONDITIONS PLAN FOR BENCHMARK INFORMATION.
- 2) COORDINATE ALL UTILITY WORK WITH APPROPRIATE UTILITY.
- 3) SEE GRADING AND DRAINAGE PLAN FOR PROPOSED GRADING AND EROSION CONTROL MEASURES.
- 4) ALL WATER SERVICE INSTALLATIONS SHALL BE PRESSURE TESTED AND CHLORINATED AFTER CONSTRUCTION AND BEFORE ACTIVATING THE SYSTEM. CONTRACTOR SHALL COORDINATE WITH THE CITY OF PORTSMOUTH.
- 5) ALL SEWER PIPE SHALL BE PVC SDR 35 UNLESS OTHERWISE STATED.
- 6) ALL WORK WITHIN CITY R.O.W. SHALL BE COORDINATED WITH CITY OF PORTSMOUTH.
- 7) CONTRACTOR SHALL MAINTAIN UTILITY SERVICES TO ADJUTING PROPERTIES THROUGHOUT CONSTRUCTION.
- 8) ALL ELECTRICAL MATERIAL WORKMANSHIP SHALL CONFORM TO THE NATIONAL ELECTRIC CODE, LATEST EDITION, AND ALL APPLICABLE STATE AND LOCAL CODES.
- 9) THE EXACT LOCATION OF NEW UTILITY SERVICES AND CONNECTIONS SHALL BE COORDINATED WITH BUILDING DRAWINGS AND UTILITY COMPANIES.
- 10) ADJUST ALL MANHOLES, CATCH BASINS, CURB BOXES, ETC. WITHIN LIMITS OF WORK TO FINISH GRADE.
- 11) THE CONTRACTOR SHALL OBTAIN, PAY FOR, AND COMPLY WITH ALL REQUIRED PERMITS, ARRANGE FOR ALL INSPECTIONS, AND SUBMIT COPIES OF ACCEPTANCE CERTIFICATED TO THE OWNER PRIOR TO THE COMPLETION OF PROJECT.
- 12) THE CONTRACTOR SHALL PROVIDE AND INSTALL ALL MANHOLES, BOXES, FITTINGS, CONNECTORS, COVER PLATES AND OTHER MISCELLANEOUS ITEMS NOT NECESSARILY DETAILED IN THESE DRAWING TO RENDER INSTALLATION OF UTILITIES COMPLETE AND OPERATIONAL.
- 13) CONTRACTOR SHALL PROVIDE EXCAVATION, BEDDING, BACKFILL AND COMPACTION FOR ALL UTILITIES.
- 14) A 10-FOOT MINIMUM EDGE TO EDGE HORIZONTAL SEPARATION SHALL BE PROVIDED BETWEEN ALL WATER AND SANITARY SEWER LINES. AN 18-INCH MINIMUM OUTSIDE TO OUTSIDE VERTICAL SEPARATION SHALL BE PROVIDED AT ALL WATER/SANITARY SEWER CROSSINGS WATER ABOVE SEWER.
- 15) VALVES, FITTINGS, ETC. SHALL MEET THE REQUIREMENTS OF THE CITY OF PORTSMOUTH.
- 16) COORDINATE TESTING OF SEWER CONSTRUCTION WITH THE CITY OF PORTSMOUTH.

NOTES:

- 1) THE CONTRACTOR SHALL NOTIFY DIG SAFE AT 1-888-DIG-SAFE (1-888-344-7233) AT LEAST 72 HOURS PRIOR TO COMMENCING ANY EXCAVATION ON PUBLIC OR PRIVATE PROPERTY WITHIN 100 FEET OF UNDERGROUND UTILITIES. THE EXCAVATOR IS RESPONSIBLE TO MAINTAIN MARKS. DIG SAFE TICKETS EXPIRE IN THIRTY DAYS.
- 2) UNDERGROUND UTILITY LOCATIONS ARE BASED UPON BEST AVAILABLE EVIDENCE AND ARE NOT FIELD VERIFIED. LOCATING AND PROTECTING ANY ABOVEGROUND OR UNDERGROUND UTILITIES IS THE SOLE RESPONSIBILITY OF THE CONTRACTOR AND/OR THE OWNER. UTILITY CONFLICTS SHOULD BE REPORTED AT ONCE TO THE DESIGN ENGINEER.
- 3) CONTRACTOR SHALL INSTALL AND MAINTAIN EROSION CONTROL MEASURES IN ACCORDANCE WITH THE "NEW HAMPSHIRE STORMWATER MANUAL, VOLUME 3, EROSION AND SEDIMENT CONTROLS DURING CONSTRUCTION. (NHDES DECEMBER 2008).
- 4) SEWER INFORMATION: SEWER SERVICE TO THE NEW BATHROOMS WILL BE CONNECTED INTERNALLY. ADDITIONAL SEWER FLOW IS NOT EXPECTED FROM THE PROPOSED ADDITION.
- 5) WATER SERVICE WILL BE EXTENDED INTERNALLY TO NEW FIXTURES FROM OLD BUILDINGS CONNECTION.

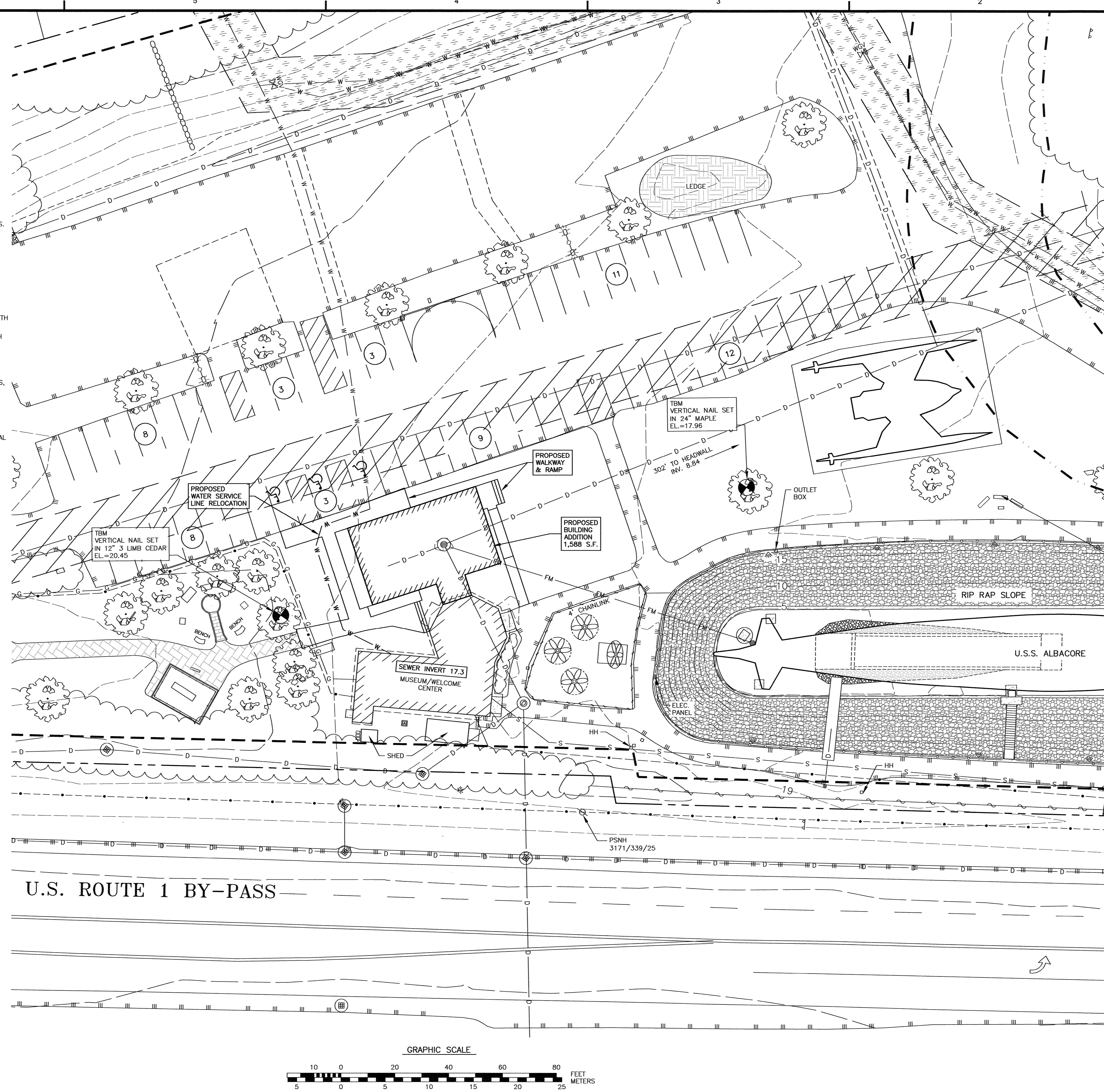

U.S. ROUTE 1 BY-PASS

GRAPHIC SCALE

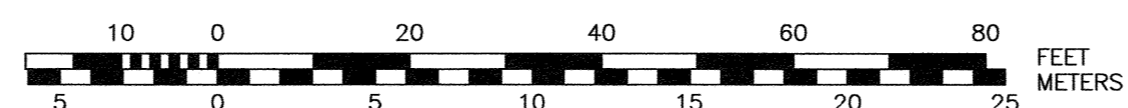

0	11/7/23	ISSUED FOR COMMENT	OMS	JRC
No.	DATE	DESCRIPTION	BY	CHK.

DRAWING ISSUE STATUS

TAC SUBMISSION



WWW.HALEYWARD.COM

200 Griffin Road, Unit 3
Portsmouth, NH 03801
603.430.9282

PROJECT

ALBACORE PARK BUILDING ADDITION
589 SUBMARINE WAY PORTSMOUTH, NEW HAMPSHIRE

TITLE

UTILITY PLAN

DATE	SCALE	
OCTOBER 2023	SCALE: 1" = 20'	
DRAWN BY	DESIGNED BY	CHECKED BY
OMS	JRC	JRC
PROJECT No.	FIELD BOOK & PAGE	
5010373-452.02	FB 347 PG 20	
SHEET No.	DWG No.	

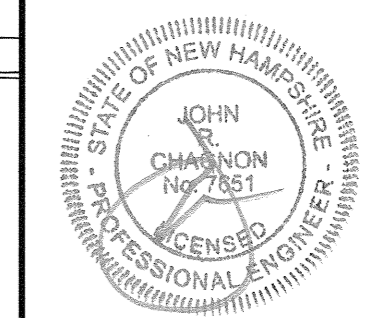

SHEET 5 C5

P:\NH\510373-Portsmouth-Submarine_Memorial_Asn\452.02-1-Submarine Way, Portsmouth-JRC\2023_Site Plan\Plans & Specs\Site\452.02_Survey_2023.dwg, 11/7/2023, 10:54:38 AM, Portsmouth Plotted Canon TX3000.pc3

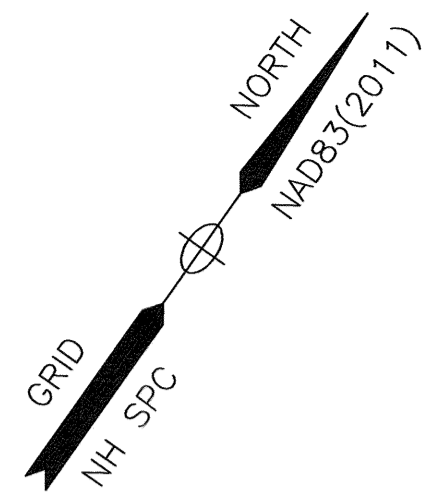

DRAINAGE STRUCTURE SCHEDULE				
STRUCTURE	PROP/EX	RIM	PIPE SIZE/TYPE	INVERT
CB 1	EX	17.74	18" C. PVC	8.84
CB 1	EX	17.74	18" PVC	8.84
CB 1	EX	17.74	(2) 4" PVC	13.84
CB 1	EX	17.74	4" CPP	11.54
CB 2	EX	18.98	12" PVC	13.68
CB 2	EX	18.98	12" PVC	13.58
CB 3	EX	16.98	12" CMP	13.43
CB 3	EX	16.98	18" RCP	13.33
CB 3	EX	16.98	12" CMP	13.12
DMH 1	EX	18.90	18" PVC	10.32
DMH 1	EX	18.90	12" PVC	12.88
DMH 2	PROP			

PIPE SCHEDULE			
PIPE #	PIPE SIZE	LENGTH	SLOPE
1		71'	

*ALL PIPE TO BE HDPE

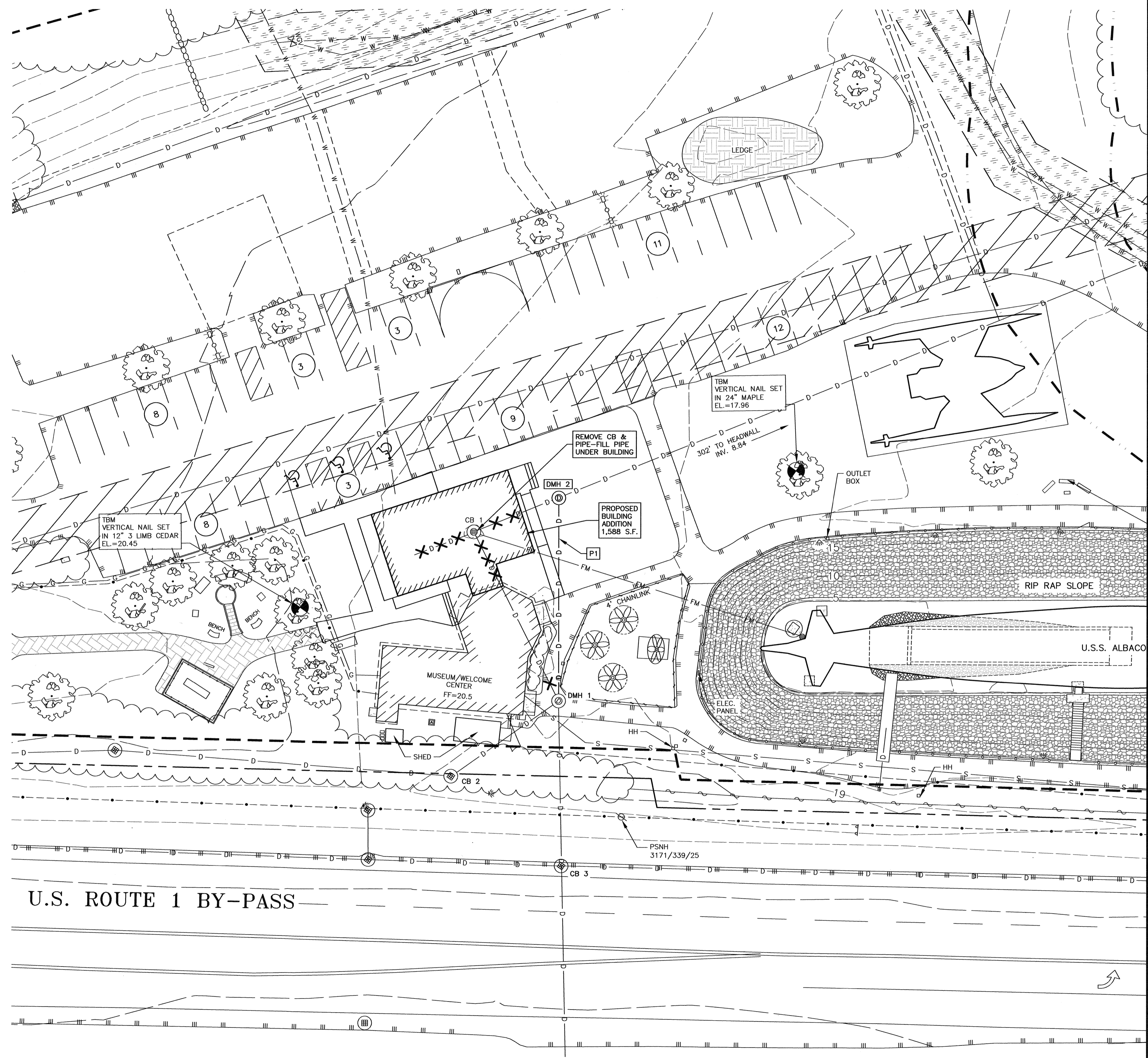

- NOTES:**
- 1) THE CONTRACTOR SHALL NOTIFY DIG SAFE AT 1-888-DIG-SAFE (1-888-344-7233) AT LEAST 72 HOURS PRIOR TO COMMENCING ANY EXCAVATION ON PUBLIC OR PRIVATE PROPERTY WITHIN 100 FEET OF UNDERGROUND UTILITIES. THE EXCAVATOR IS RESPONSIBLE TO MAINTAIN MARKS. DIG SAFE TICKETS EXPIRE IN THIRTY DAYS.
 - 2) UNDERGROUND UTILITY LOCATIONS ARE BASED UPON BEST AVAILABLE EVIDENCE AND ARE NOT FIELD VERIFIED. LOCATING AND PROTECTING ANY ABOVEGROUND OR UNDERGROUND UTILITIES IS THE SOLE RESPONSIBILITY OF THE CONTRACTOR AND/OR THE OWNER. UTILITY CONFLICTS SHOULD BE REPORTED AT ONCE TO THE DESIGN ENGINEER.
 - 3) CONTRACTOR SHALL INSTALL AND MAINTAIN EROSION CONTROL MEASURES IN ACCORDANCE WITH THE "NEW HAMPSHIRE STORMWATER MANUAL, VOLUME 3, EROSION AND SEDIMENT CONTROLS DURING CONSTRUCTION. (NHDES DECEMBER 2008).

0	11/7/23	ISSUED FOR COMMENT	OMS	JRC
No.	DATE	DESCRIPTION	BY	CHK.

TAC SUBMISSION

AMBIT ENGINEERING, INC.
A DIVISION OF HALEY WARD, INC.

200 Griffin Road, Unit 3
Portsmouth, NH 03801
603.430.9282

WWW.HALEYWARD.COM

PROJECT
ALBACORE PARK BUILDING ADDITION
569 SUBMARINE WAY PORTSMOUTH, NEW HAMPSHIRE

TITLE
GRADING & DRAINAGE PLAN

DATE OCTOBER 2023	SCALE SCALE: 1" = 20'
DRAWN BY OMS	DESIGNED BY JRC
CHECKED BY JRC	
PROJECT No. 5010373-452.02	FIELD BOOK & PAGE FB 347 PG 20
SHEET No. SHEET 6	DWG No. C6

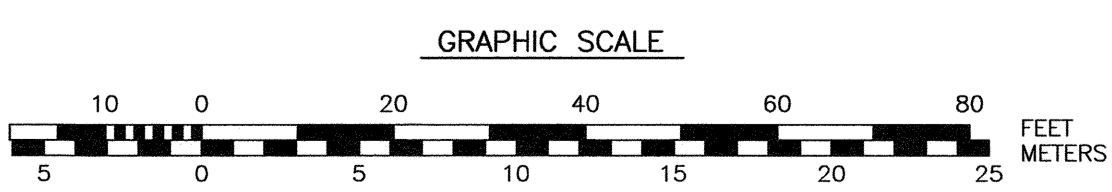

P:\NH\5010373-Portsmouth-Submarine-Memorial-Asyn\452.02-1-Submarine-Way-Portsmouth-IRC\2023-Site-Plan\Plans-&-Specs\Site\452.02-Survey-2023.dwg, 11/7/2023, 10:00 PM, Portsmouth Plotted, Chom TX9000.pct

EROSION CONTROL NOTES

CONSTRUCTION SEQUENCE

DO NOT BEGIN CONSTRUCTION UNTIL ALL LOCAL, STATE AND FEDERAL PERMITS HAVE BEEN APPLIED FOR AND RECEIVED.

IF REQUIRED THE CONTRACTOR SHALL OBTAIN AN NPDES PHASE II STORMWATER PERMIT AND SUBMIT A NOTICE OF INTENT (N.O.I.) BEFORE BEGINNING CONSTRUCTION AND SHALL HAVE ON SITE A STORMWATER POLLUTION PREVENTION PLAN (S.W.P.P.P.) AVAILABLE FOR INSPECTION BY THE PERMITTING AUTHORITY DURING THE CONSTRUCTION. THE CONTRACTOR SHALL BE RESPONSIBLE FOR CARRYING OUT THE S.W.P.P.P. AND INSPECTING AND MAINTAINING ALL BMP'S CALLED FOR BY THE PLAN. THE CONTRACTOR SHALL SUBMIT A NOTICE OF TERMINATION (N.O.T.) FORM TO THE REGIONAL EPA OFFICE WITHIN 30 DAYS OF FINAL STABILIZATION OF THE ENTIRE SITE OR TURNING OVER CONTROL OF THE SITE TO ANOTHER OPERATOR.

THE FOLLOWING REPRESENTS THE GENERAL OBSERVATION AND REPORTING PRACTICES THAT SHALL BE FOLLOWED AS PART OF THIS PROJECT.

- OBSERVATIONS OF THE PROJECT FOR COMPLIANCE WITH THE SWPPP SHALL BE MADE BY THE CONTRACTOR AT LEAST ONCE A WEEK OR WITHIN 24 HOURS OF A STORM 0.25 INCHES OR GREATER;
- AN OBSERVATION REPORT SHALL BE MADE AFTER EACH OBSERVATION AND DISTRIBUTED TO THE ENGINEER, THE OWNER, AND THE CONTRACTOR;
- A REPRESENTATIVE OF THE SITE CONTRACTOR SHALL BE RESPONSIBLE FOR MAINTENANCE AND REPAIR ACTIVITIES;
- IF A REPAIR IS NECESSARY, IT SHALL BE INITIATED WITHIN 24 HOURS OF REPORT.

INSTALL PERIMETER CONTROLS, I.E., SILT/SOXX AND CATCH BASIN PROTECTION AROUND THE LIMITS OF DISTURBANCE BEFORE ANY EARTH MOVING OPERATIONS. THE USE OF HAYBALES IS NOT ALLOWED.

THE CONTRACTOR SHALL CONSTRUCT STABILIZED CONSTRUCTION ENTRANCE(S) PRIOR TO ANY EXCAVATION ACTIVITIES. PLACE FOODS AS NEEDED.

CUT AND GRUB ALL TREES, SHRUBS, SAPLINGS, BRUSH, VINES AND REMOVE OTHER DEBRIS AND RUBBISH AS REQUIRED.

ROUGH GRADE SITE/EXCAVATE FOR FOUNDATION.

LAYOUT AND INSTALL ALL BURIED UTILITIES AND SERVICES UP TO 10' OF THE PROPOSED BUILDING FOUNDATIONS. CAP AND MARK TERMINATIONS OR LOG SWING TIES.

CONSTRUCT BUILDING.

CONNECT UTILITIES.

PLACE BINDER LAYER OF PAVEMENT FOR SIDEWALKS.

PLANT LANDSCAPING IN AREAS OUT OF WAY OF BUILDING CONSTRUCTION. PREPARE AND STABILIZE FINAL SITE GRADING BY ADDING TOPSOIL, SEED, MULCH AND FERTILIZER.

AFTER BUILDINGS ARE COMPLETED, FINISH ALL REMAINING LANDSCAPED WORK.

CONSTRUCT SIDEWALKS.

REMOVE TRAPPED SEDIMENTS FROM COLLECTION DEVICES AS APPROPRIATE, AND THEN REMOVE TEMPORARY EROSION CONTROL MEASURES UPON COMPLETION OF FINAL STABILIZATION OF THE SITE.

PROJECT DESCRIPTION

THE PROJECT CONSISTS OF A BUILDING ADDITION WITH WALKWAYS.

THE TOTAL AREA TO BE DISTURBED IS APPROXIMATELY 10,000 S.F.

BASED ON THE USCS WEB SOIL SURVEY THE SOILS ON SITE CONSIST OF 799 WHICH IS URBAN LAND COMPLEX. SITE WAS DISTURBED FOR PARK CONSTRUCTION.

THE STORMWATER RUNOFF FROM THE SITE WILL BE DISCHARGED VIA A CLOSED DRAINAGE SYSTEM TO THE CITY OF PORTSMOUTH CLOSED DRAINAGE SYSTEM WHICH ULTIMATELY FLOWS TO INNER INNER CUTS COVE THEN TO THE PISCATAQUA RIVER.

GENERAL CONSTRUCTION NOTES

THE EROSION CONTROL PROCEDURES SHALL CONFORM TO SECTION 645 OF THE "STANDARD SPECIFICATION FOR ROAD AND BRIDGE CONSTRUCTION" OF THE NHDOT, AND "STORM WATER MANAGEMENT AND EROSION AND SEDIMENT CONTROL HANDBOOK FOR URBAN AND DEVELOPING AREAS IN NEW HAMPSHIRE". THE PROJECT IS TO BE MANAGED IN A MANNER THAT MEETS THE REQUIREMENTS AND INTENT OF RSA 430:53 AND CHAPTER AGR 3800 RELATIVE TO INVASIVE SPECIES.

DURING CONSTRUCTION AND THEREAFTER, EROSION CONTROL MEASURES ARE TO BE IMPLEMENTED AS NOTED. THE SMALLEST PRACTICAL AREA OF LAND SHOULD BE EXPOSED AT ANY ONE TIME DURING DEVELOPMENT. NO DISTURBED AREA SHALL BE LEFT UNSTABILIZED FOR MORE THAN 45 DAYS.

ANY DISTURBED AREAS WHICH ARE TO BE LEFT TEMPORARILY, AND WHICH WILL BE REGRADED LATER DURING CONSTRUCTION SHALL BE MACHINE HAY MULCHED AND SEEDED WITH RYE GRASS TO PREVENT EROSION.

THE PROJECT IS TO BE MANAGED IN A MANNER THAT MEETS THE REQUIREMENTS AND INTENT OF RSA 430:53 AND CHAPTER AGR 3800 RELATIVE TO INVASIVE SPECIES.

DUST CONTROL: DUST CONTROL MEASURES SHALL INCLUDE BUT ARE NOT LIMITED TO SPRINKLING WATER ON EXPOSED AREAS, COVERING LOADED DUMP TRUCKS LEAVING THE SITE, AND TEMPORARY MULCHING.

DUST CONTROL MEASURES SHALL BE UTILIZED SO AS TO PREVENT THE MIGRATION OF DUST FROM THE SITE TO ADJUTING AREAS.

IF TEMPORARY STABILIZATION PRACTICES, SUCH AS TEMPORARY VEGETATION AND MULCHING, DO NOT ADEQUATELY REDUCE DUST GENERATION, APPLICATION OF WATER OR CALCIUM CHLORIDE SHALL BE APPLIED IN ACCORDANCE WITH BEST MANAGEMENT PRACTICES.

SILT/SOXX SHALL BE PERIODICALLY INSPECTED DURING THE LIFE OF THE PROJECT AND AFTER EACH STORM. ALL DAMAGED SILT/SOXX SHALL BE REPAIRED. SEDIMENT DEPOSITS SHALL PERIODICALLY BE REMOVED AND DISPOSED IN A SECURED LOCATION.

ALL FILLS SHALL BE PLACED AND COMPACTED TO REDUCE EROSION, SLIPPAGE, SETTLEMENT, SUBSIDENCE OR OTHER RELATED PROBLEMS.

ALL NON-STRUCTURAL, SITE-FILL SHALL BE PLACED AND COMPACTED TO 90% MODIFIED PROCTOR DENSITY IN LAYERS NOT EXCEEDING 18 INCHES IN THICKNESS UNLESS OTHERWISE NOTED.

FROZEN MATERIAL OR SOFT, MUCKY OR HIGHLY COMPRESSIBLE MATERIAL, TRASH, WOODY DEBRIS, LEAVES, BRUSH OR ANY DELETERIOUS MATTER SHALL NOT BE INCORPORATED INTO FILLS.

FILL MATERIAL SHALL NOT BE PLACED ON FROZEN FOUNDATION SUBGRADE.

DURING CONSTRUCTION AND UNTIL ALL DEVELOPED AREAS ARE FULLY STABILIZED, ALL EROSION CONTROL MEASURES SHALL BE INSPECTED WEEKLY AND AFTER EACH ONE HALF INCH OF RAINFALL.

THE CONTRACTOR SHALL MODIFY OR ADD EROSION CONTROL MEASURES AS NECESSARY TO ACCOMMODATE PROJECT CONSTRUCTION.

ALL ROADWAYS AND PARKING AREAS SHALL BE STABILIZED WITHIN 72 HOURS OF ACHIEVING FINISHED GRADE. ALL CUT AND FILL SLOPES SHALL BE SEEDDED/LOADED WITHIN 72 HOURS OF ACHIEVING FINISHED GRADE.

AN AREA SHALL BE CONSIDERED STABLE IF ONE OF THE FOLLOWING HAS OCCURRED:

- BASE COURSE GRAVELS HAVE BEEN INSTALLED ON AREAS TO BE PAVED
- A MINIMUM OF 85% VEGETATED GROWTH HAS BEEN ESTABLISHED
- A MINIMUM OF 3 INCHES OF NON-EROSIVE MATERIAL SUCH AS STONE OR RIPRAP HAS BEEN INSTALLED
- EROSION CONTROL BLANKETS HAVE BEEN INSTALLED.
- IN AREAS TO BE PAVED, "STABLE" MEANS THAT BASE COURSE GRAVELS MEETING THE REQUIREMENTS OF NHDOT STANDARD FOR ROAD AND BRIDGE CONSTRUCTION, 2016, ITEM 304.2 HAVE BEEN INSTALLED.

STABILIZATION SHALL BE INITIATED ON ALL LOAM STOCKPILES, AND DISTURBED AREAS, WHERE CONSTRUCTION ACTIVITY SHALL NOT OCCUR FOR MORE THAN TWENTY-ONE (21) CALENDAR DAYS BY THE FOURTEENTH (14TH) DAY AFTER CONSTRUCTION ACTIVITY HAS PERMANENTLY OR TEMPORARILY CEASED IN THAT AREA.

STABILIZATION MEASURES TO BE USED INCLUDE:

- TEMPORARY SEEDING;
- MULCHING.

- ALL AREAS SHALL BE STABILIZED WITHIN 45 DAYS OF INITIAL DISTURBANCE.
- WHEN CONSTRUCTION ACTIVITY PERMANENTLY OR TEMPORARILY CEASES WITHIN 100 FEET OF NEARBY SURFACE WATERS OR DELINEATED WETLANDS, THE AREA SHALL BE STABILIZED WITHIN SEVEN (7) DAYS OR PRIOR TO A RAIN EVENT. ONCE CONSTRUCTION ACTIVITY CEASES PERMANENTLY IN THESE AREAS, SILT/SOXX, MULCH BERMS, HAY BALE BARRIERS AND ANY EARTH/DIKES SHALL BE REMOVED ONCE PERMANENT MEASURES ARE ESTABLISHED.
- DURING CONSTRUCTION, RUNOFF WILL BE DIVERTED AROUND THE SITE WITH EARTH DIKES, PIPING OR STABILIZED CHANNELS WHERE POSSIBLE. SHEET RUNOFF FROM THE SITE WILL BE FILTERED THROUGH SILT/SOXX, MULCH BERMS, HAY BALE BARRIERS, OR SILT SOCKS. ALL STORM DRAIN BASIN INLETS SHALL BE PROVIDED WITH FLARED END SECTIONS AND TRASH RACKS. THE SITE SHALL BE STABILIZED FOR THE WINTER BY OCTOBER 15.

MAINTENANCE AND PROTECTION

THE SILT/SOXX BARRIER SHALL BE CHECKED AFTER EACH RAINFALL AND AT LEAST DAILY DURING PROLONGED RAINFALL.

SILT/SOXX SHALL BE REMOVED ONCE SITE IS STABILIZED, AND DISTURBED AREAS RESULTING FROM SILT/SOXX REMOVAL SHALL BE PERMANENTLY SEEDDED.

THE CATCH BASIN INLET BASKET SHALL BE INSPECTED WITHIN 24 HOURS AFTER EACH RAINFALL OR DAILY DURING EXTENDED PERIODS OF PRECIPITATION. REPAIRS SHALL BE MADE IMMEDIATELY, AS NECESSARY, TO PREVENT PARTICLES FROM REACHING THE DRAINAGE SYSTEM AND/OR CAUSING SURFACE FLOODING. SEDIMENT DEPOSITS SHALL BE REMOVED AFTER EACH STORM EVENT, OR MORE OFTEN IF THE FABRIC BECOMES CLOGGED.

WINTER NOTES

ALL PROPOSED VEGETATED AREAS THAT DO NOT EXHIBIT A MINIMUM OF 85% VEGETATED GROWTH BY OCTOBER 15, OR WHICH ARE DISTURBED AFTER OCTOBER 15, SHALL BE STABILIZED BY SEEDING AND INSTALLING EROSION CONTROL BLANKETS ON SLOPES GREATER THAN 3:1, AND SEEDING AND PLACING 3 TO 4 TONS OF MULCH PER ACRE, SECURED WITH ANCHORED NETTING, ELSEWHERE. THE INSTALLATION OF EROSION CONTROL BLANKETS OR MULCH AND NETTING SHALL NOT OCCUR OVER ACCUMULATED SNOW OR ON FROZEN GROUND AND SHALL BE COMPLETED IN ADVANCE OF THAW OR SPRING MELT EVENTS.

ALL DITCHES OR SWALES WHICH DO NOT EXHIBIT A MINIMUM OF 85 PERCENT VEGETATIVE GROWTH BY OCTOBER 15, OR WHICH ARE DISTURBED AFTER OCTOBER 15, SHALL BE STABILIZED TEMPORARILY WITH STONE OR EROSION CONTROL BLANKETS APPROPRIATE FOR THE DESIGN FLOW CONDITIONS;

AFTER OCTOBER 15, INCOMPLETE ROAD OR PARKING SURFACES, WHERE WORK HAS STOPPED FOR THE WINTER SEASON, SHALL BE PROTECTED WITH A MINIMUM OF 3 INCHES OF CRUSHED GRAVEL PER NHDOT ITEM 304.3, OR IF CONSTRUCTION IS TO CONTINUE THROUGH THE WINTER SEASON BE CLEARED OF ANY ACCUMULATED SNOW AFTER EACH STORM EVENT;

STOCKPILES

- LOCATE STOCKPILES A MINIMUM OF 50 FEET AWAY FROM CATCH BASINS, SWALES, AND CULVERTS.
- ALL STOCKPILES SHOULD BE SURROUNDED WITH TEMPORARY EROSION CONTROL MEASURES PRIOR TO THE ONSET OF PRECIPITATION.
- PERIMETER BARRIERS SHOULD BE MAINTAINED AT ALL TIMES, AND ADJUSTED AS NEEDED TO ACCOMMODATE THE DELIVERY AND REMOVAL OF MATERIALS FROM THE STOCKPILE. THE INTEGRITY OF THE BARRIER SHOULD BE INSPECTED AT THE END OF EACH WORKING DAY.
- PROTECT ALL STOCKPILES FROM STORMWATER RUN-OFF USING TEMPORARY EROSION CONTROL MEASURES SUCH AS BERMS, SILT SOCK, OR OTHER APPROVED PRACTICE TO PREVENT MIGRATION OF MATERIAL BEYOND THE IMMEDIATE CONFINES OF THE STOCKPILES.

CONCRETE WASHOUT AREA

THE FOLLOWING ARE THE ONLY NON-STORMWATER DISCHARGES ALLOWED. ALL OTHER NON-STORMWATER DISCHARGES ARE PROHIBITED ON SITE:

- THE CONCRETE DELIVERY TRUCKS SHALL, WHENEVER POSSIBLE, USE WASHOUT FACILITIES AT THEIR OWN PLANT OR DISPATCH FACILITY;
- IF IT IS NECESSARY, SITE CONTRACTOR SHALL DESIGNATE SPECIFIC WASHOUT AREAS AND DESIGN FACILITIES TO HANDLE ANTICIPATED WASHOUT WATER;
- CONTRACTOR SHALL LOCATE WASHOUT AREAS AT LEAST 150 FEET AWAY FROM STORM DRAINS, SWALES AND SURFACE WATERS OR DELINEATED WETLANDS;
- INSPECT WASHOUT FACILITIES DAILY TO DETECT LEAKS OR TEARS AND TO IDENTIFY WHEN MATERIALS NEED TO BE REMOVED.

ALLOWABLE NON-STORMWATER DISCHARGES

- FIRE-FIGHTING ACTIVITIES;
- FIRE HYDRANT FLUSHING;
- WATERS USED TO WASH VEHICLES WHERE DETERGENTS ARE NOT USED;
- WATER USED TO CONTROL DUST;
- POTABLE WATER INCLUDING UNCONTAMINATED WATER LINE FLUSHING;
- ROUTINE EXTERNAL BUILDING WASH DOWN WHERE DETERGENTS ARE NOT USED;
- PAVEMENT WASH WATERS WHERE DETERGENTS ARE NOT USED;
- UNCONTAMINATED AIR CONDITIONING/COMPRESSOR CONDENSATION;
- UNCONTAMINATED GROUND WATER OR SPRING WATER;
- FOUNDATION OR FOOTING DRAINS WHICH ARE UNCONTAMINATED;
- UNCONTAMINATED EXCAVATION Dewatering;
- LANDSCAPE IRRIGATION.

WASTE DISPOSAL

- WASTE MATERIAL
 - ALL WASTE MATERIALS SHALL BE COLLECTED AND STORED IN SECURELY LIDDED RECEPTACLES. ALL TRASH AND CONSTRUCTION DEBRIS FROM THE SITE SHALL BE DEPOSITED IN A DUMPSTER;
 - NO CONSTRUCTION WASTE MATERIALS SHALL BE BURIED ON SITE;
 - ALL PERSONNEL SHALL BE INSTRUCTED REGARDING THE CORRECT PROCEDURE FOR WASTE DISPOSAL BY THE SUPERINTENDENT.
- HAZARDOUS WASTE
 - ALL HAZARDOUS WASTE MATERIALS SHALL BE DISPOSED OF IN THE MANNER SPECIFIED BY LOCAL OR STATE REGULATION OR BY THE MANUFACTURER;
 - SITE PERSONNEL SHALL BE INSTRUCTED IN THESE PRACTICES BY THE SUPERINTENDENT.
- SANITARY WASTE
 - ALL SANITARY WASTE SHALL BE COLLECTED FROM THE PORTABLE UNITS A MINIMUM OF ONCE PER WEEK BY A LICENSED SANITARY WASTE MANAGEMENT CONTRACTOR.

BLASTING NOTES

- CONTRACTOR SHALL CONTACT THE NHDES AND/OR LOCAL JURISDICTION PRIOR TO COMMENCING ANY BLASTING ACTIVITIES.
- FOR ANY PROJECT FOR WHICH BLASTING OF BEDROCK IS ANTICIPATED, THE APPLICANT SHALL SUBMIT A BLASTING PLAN THAT IDENTIFIES:
 - WHERE THE BLASTING ACTIVITIES ARE ANTICIPATED TO OCCUR;
 - THE ESTIMATED QUANTITY OF BLAST ROCK IN CUBIC YARDS; AND
 - SITE-SPECIFIC BLASTING BEST MANAGEMENT PRACTICES.

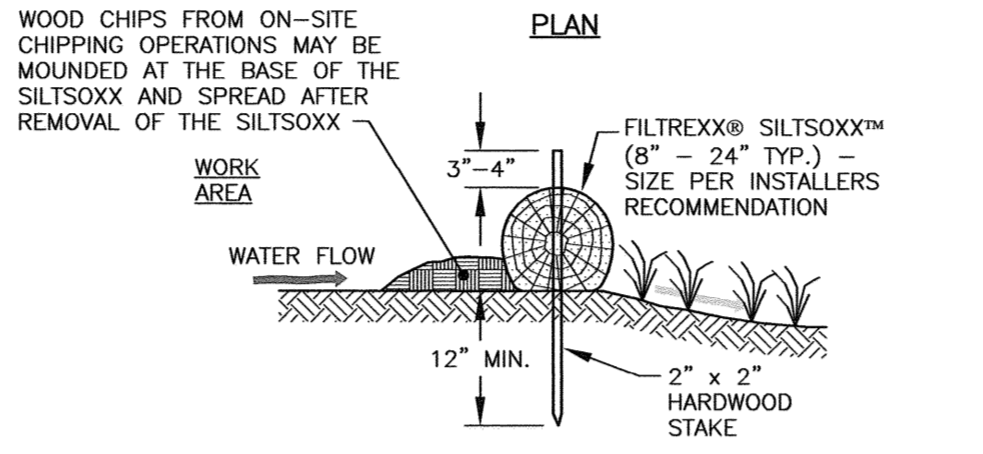
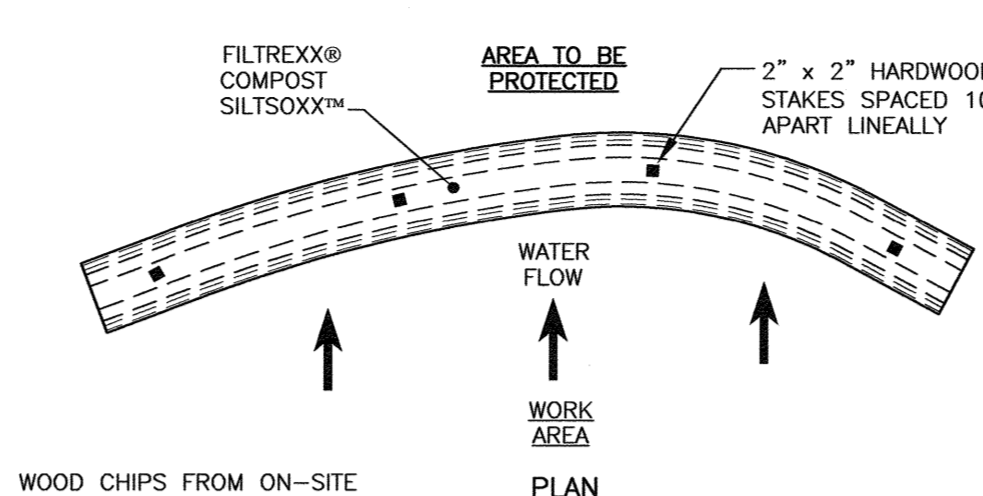

- NOTES:
- ALL MATERIAL TO MEET FILTREXX SPECIFICATIONS.
 - FILTREXX SYSTEM SHALL BE INSTALLED BY A CERTIFIED FILTREXX INSTALLER.
 - THE CONTRACTOR SHALL MAINTAIN THE COMPOST FILTRATION SYSTEM IN A FUNCTIONAL CONDITION AT ALL TIMES. IT WILL BE ROUTINELY INSPECTED AND REPAIRED WHEN REQUIRED.
 - SILT/SOXX DEPICTED IS FOR MINIMUM SLOPES, GREATER SLOPES MAY REQUIRE ADDITIONAL PLACEMENTS.
 - THE COMPOST FILTER MATERIAL WILL BE DISPERSED ON SITE WHEN NO LONGER REQUIRED, AS DETERMINED BY THE ENGINEER.

FILTREXX® SILT/SOXX™ FILTRATION SYSTEM

NTS

FOODS TRACKOUT CONTROL SYSTEM

INSTALLATION:

THE PURPOSE AND DESIGN OF THE FOODS TRACKOUT CONTROL SYSTEM IS TO EFFECTIVELY REMOVE MOST SEDIMENT FROM VEHICULAR TIRES AS THEY EXIT A DISTURBED LAND AREA ONTO A PAVED STREET. THIS MANUAL IS A PLATFORM FROM WHICH TO INSTALL A FOODS TRACKOUT CONTROL SYSTEM. (NOTE: THIS IS NOT A ONE SIZE FITS ALL GUIDE.) THE INSTALLATION MAY NEED TO BE MODIFIED TO MEET THE EXISTING CONDITIONS, EXPECTATIONS, OR DEMANDS OF A PARTICULAR SITE. THIS IS A GUIDELINE. ULTIMATELY THE FOODS TRACKOUT CONTROL SYSTEM SHOULD BE INSTALLED SAFELY WITH PROPER ANCHORING AND SIGNS PLACED AT THE ENTRANCE AND EXIT TO CAUTION USERS AND OTHERS.

KEY NOTES:

- FOODS TRACKOUT CONTROL SYSTEM MAT.
- FOODS SAFETY SIGN.
- ANCHOR POINT.
- SILT/SOXX OR ORANGE CONSTRUCTION FENCE.

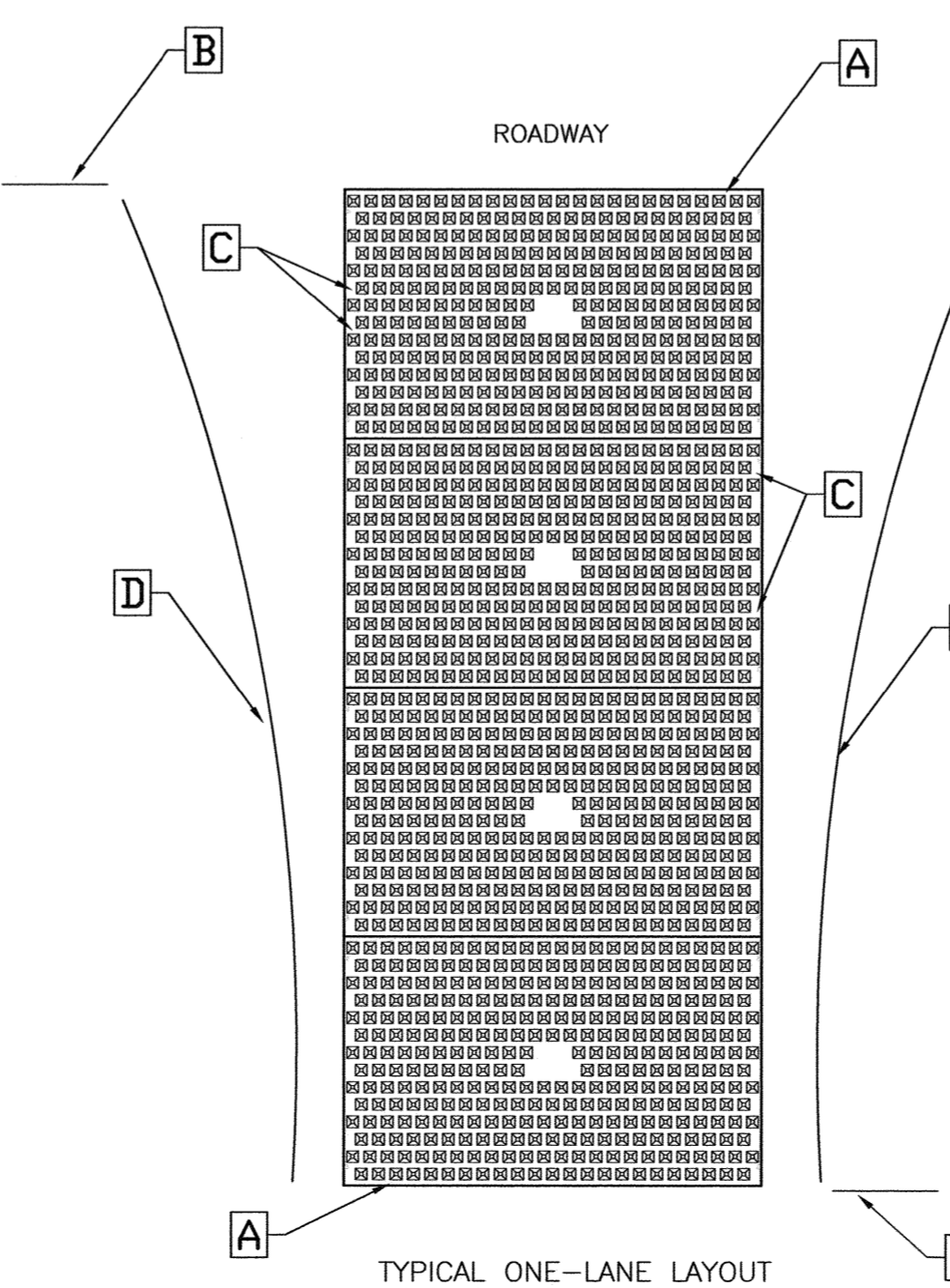

FODS (OPTIONAL)

NTS

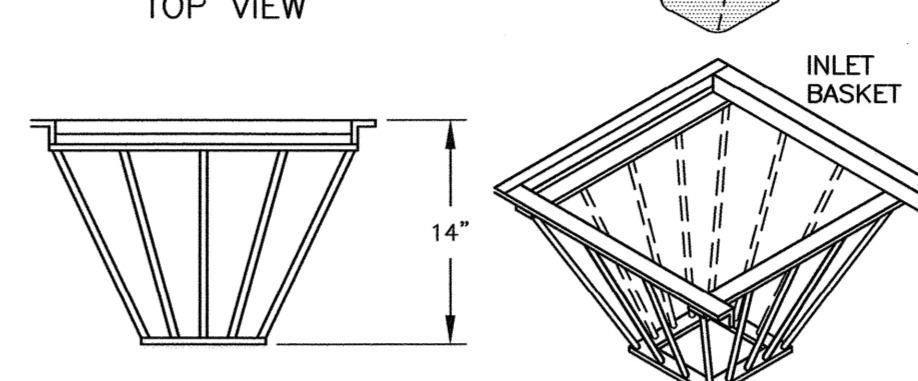
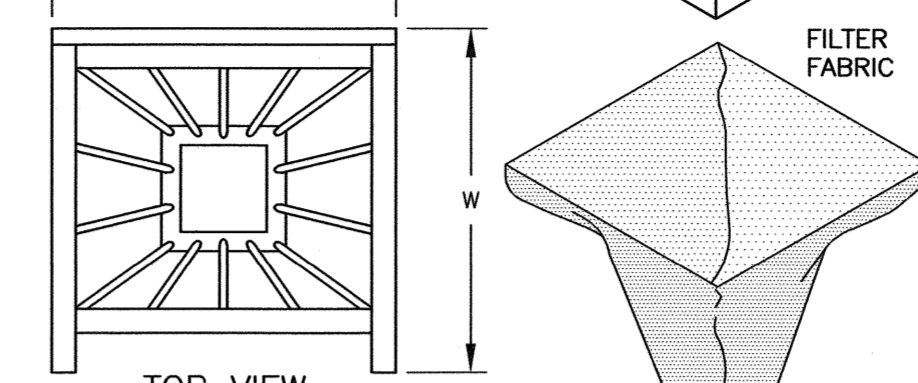
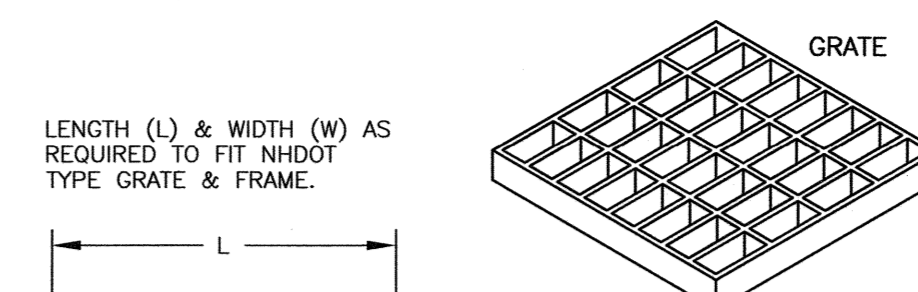

CATCH BASIN INLET BASKET

NTS

- INLET BASKETS SHALL BE INSTALLED IMMEDIATELY AFTER CATCH BASIN CONSTRUCTION IS COMPLETE AND SHALL REMAIN IN PLACE AND BE MAINTAINED UNTIL PAVEMENT BINDER COURSE IS COMPLETE.
- FILTER FABRIC SHALL BE PUSHED DOWN AND FORMED TO THE SHAPE OF THE BASKET. THE SHEET OF FABRIC SHALL BE LARGE ENOUGH TO BE SUPPORTED BY THE BASKET FRAME WHEN HOLDING SEDIMENT AND, SHALL EXTEND AT LEAST 6" PAST THE FRAME. THE INLET GRATE SHALL BE PLACED OVER THE BASKET/FRAME AND WILL SERVE AS THE FABRIC ANCHOR.
- THE FILTER FABRIC SHALL BE A GEOTEXTILE FABRIC; POLYESTER, POLYPROPYLENE, STABILIZED NYLON, POLYETHYLENE, OR POLYVINYLIDENE CHLORIDE MEETING THE FOLLOWING SPECIFICATIONS:
 - RAS STRENGTH: 45 LB. MIN. IN ANY PRINCIPAL DIRECTION (ASTM D1682)
 - MULLEN BURST STRENGTH: MIN. 60 psi (ASTM D774)
- THE FABRIC SHALL HAVE AN OPENING NO GREATER THAN A NUMBER 20 U.S. STANDARD SIEVE AND A MINIMUM PERMEABILITY OF 120 gpm/s.f. (MULTIPLY THE PERMITTIVITY IN SEC.-1 FROM ASTM 54491-85 CONSTANT HEAD TEST USING THE CONVERSION FACTOR OF 74.)
- THE INLET BASKET SHALL BE INSPECTED WITHIN 24 HOURS AFTER EACH RAINFALL OR DAILY DURING EXTENDED PERIODS OF PRECIPITATION. REPAIRS SHALL BE MADE IMMEDIATELY, AS NECESSARY, TO PREVENT PARTICLES FROM REACHING THE DRAINAGE SYSTEM AND/OR CAUSING SURFACE FLOODING.
- SEDIMENT DEPOSITS SHALL BE REMOVED AFTER EACH STORM EVENT, OR MORE OFTEN IF THE FABRIC BECOMES CLOGGED.

CATCH BASIN INLET BASKET

NTS

NOTES:

- THE CONTRACTOR SHALL NOTIFY DIG SAFE AT 1-888-DIG-SAFE (1-888-344-7233) AT LEAST 72 HOURS PRIOR TO COMMENCING ANY EXCAVATION ON PUBLIC OR PRIVATE PROPERTY.
- UNDERGROUND UTILITY LOCATIONS ARE BASED UPON BEST AVAILABLE EVIDENCE AND ARE NOT FIELD VERIFIED. LOCATING AND PROTECTING ANY ABOVEGROUND OR UNDERGROUND UTILITIES IS THE SOLE RESPONSIBILITY OF THE CONTRACTOR AND/OR THE OWNER. UTILITY CONFLICTS SHOULD BE REPORTED AT ONCE TO THE DESIGN ENGINEER.
- CONTRACTOR SHALL INSTALL AND MAINTAIN EROSION CONTROL MEASURES IN ACCORDANCE WITH THE "NEW HAMPSHIRE STORMWATER MANUAL, VOLUME 3, EROSION AND SEDIMENT CONTROLS DURING CONSTRUCTION. (NHDES DECEMBER 2008).

0	11/7/23	ISSUED FOR COMMENT	OMS	JRC
No.	DATE	DESCRIPTION	BY	CHK.

DRAWING ISSUE STATUS

TAC SUBMISSION



200 Griffin Road, Unit 3
Portsmouth, NH 03801
603.430.1922

WWW.HALEYWARD.COM

PROJECT

ALBACORE PARK BUILDING ADDITION
569 SUBMARINE WAY PORTSMOUTH, NEW HAMPSHIRE

TITLE



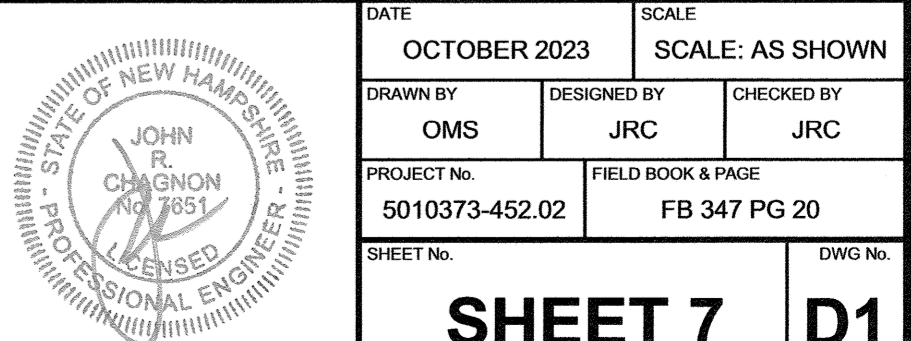

EROSION PROTECTION NOTES & DETAILS

DATE	SCALE
OCTOBER 2023	SCALE: AS SHOWN
DRAWN BY OMS	DESIGNED BY JRC
CHECKED BY JRC	
PROJECT No. 5010373-452.02	FIELD BOOK & PAGE FB 347 PG 20
SHEET No.	DWG No.
SHEET 7	D1



P:\NH\5010373-Portsmouth_Submarine_Memorial_Asst\162023_Site_Plan\Plans & Specs\Sheet\452.02_Details_New 2023.dwg, 11/6/2023 2:19:22 PM, Portsmouth Platte Canon TX3000pc3

FLOOR PLAN LEGEND

-  EXISTING BUILDING
-  EXISTING PARTITION TO REMAIN
-  NEW PARTITION
-  EXISTING DOOR TO REMAIN
-  NEW DOOR, FRAME AND/OR HARDWARE

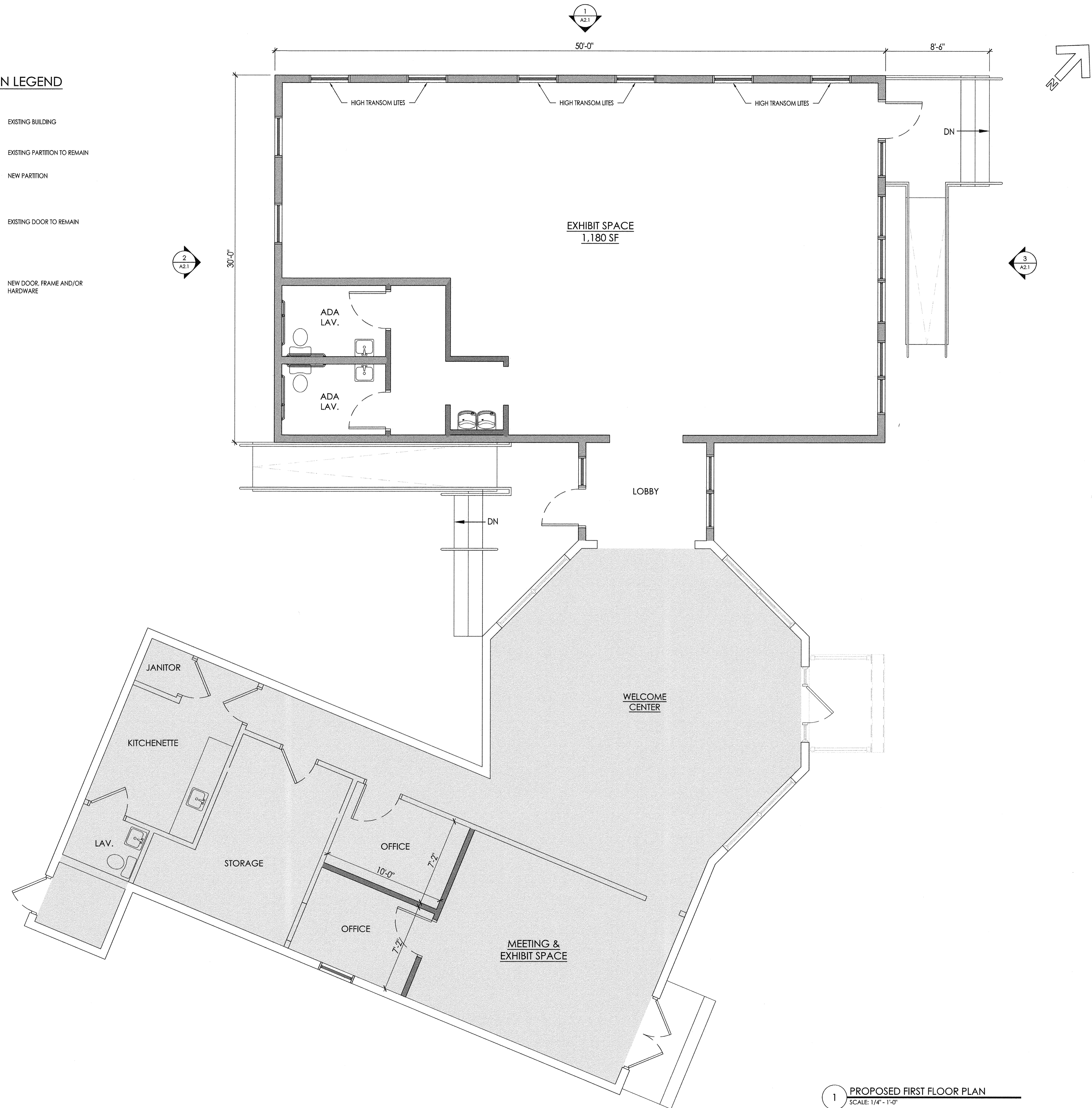

OWNER:
**ALBACORE PARK
 BUILDING COMMITTEE**
 ALBACORE PARK
 PORTSMOUTH, NH

ARCHITECT:
PORT ONE
 ARCHITECTS

959 Islington Street
 Portsmouth, NH 03801
 603.436.8891
 info@portonearchitects.com

CONTRACTOR:

CIVIL / STRUCTURAL ENGINEER:

MEPP ENGINEER:

Revision History		
#	Date	Issuance

SEAL

SCHEMATIC DESIGN

USE DISCLAIMER:
 COPYRIGHT © BY PORT ONE ARCHITECTS, INC. 2023
 NO RE-USE WITHOUT PERMISSION.
 LOCUS MAP

PROJECT NAME:
**ALBACORE PARK
 WELCOME CENTER
 ADDITION &
 RENOVATIONS**

DRAWING TITLE:
**SCHEMATIC
 FLOOR PLAN**

PROJECT No: 23-041
 DATE: Nov. 7, 2023
 DRAWING SCALE: As indicated
 DRAWING No:

1 PROPOSED FIRST FLOOR PLAN
 SCALE: 1/4" = 1'-0"

A1.1



3 PROPOSED NORTH EXTERIOR ELEVATION
SCALE: 1/4" = 1'-0"

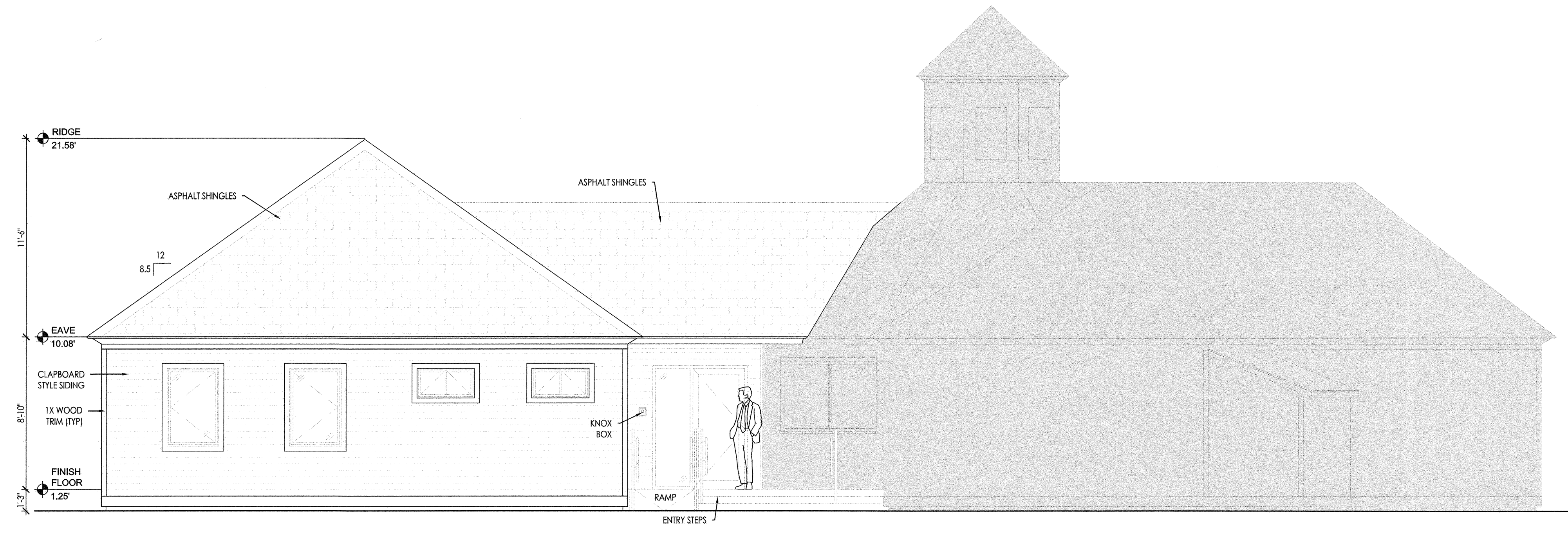

2 PROPOSED SOUTH EXTERIOR ELEVATION
SCALE: 1/4" = 1'-0"

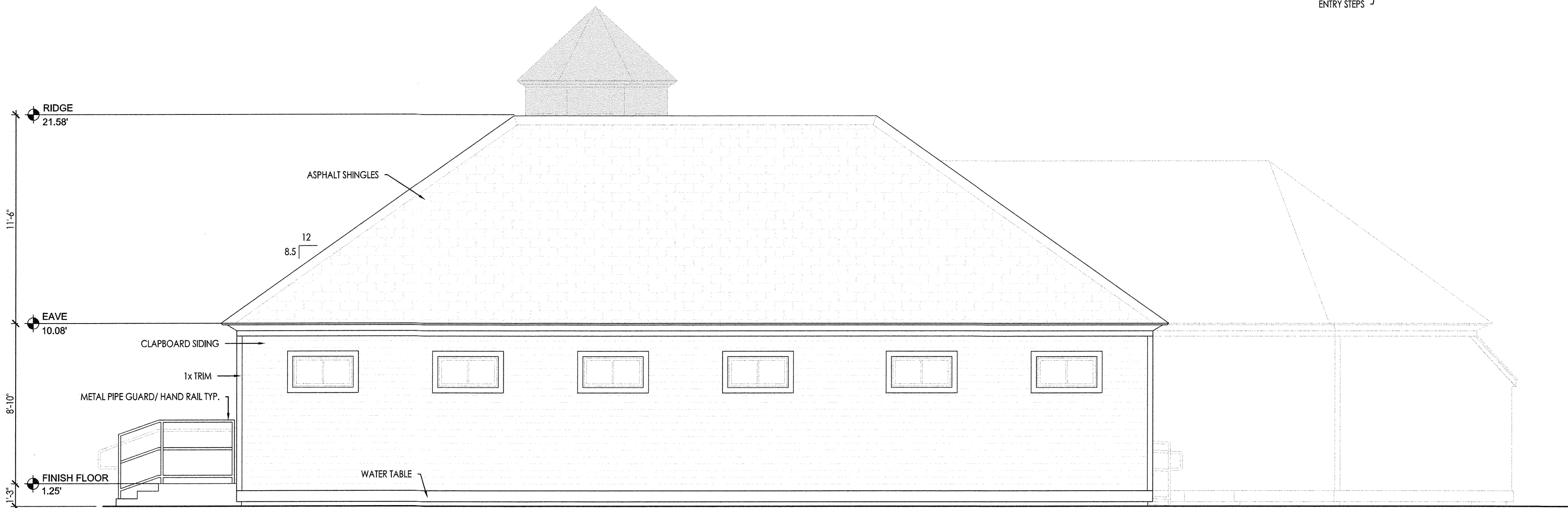

1 PROPOSED WEST EXTERIOR ELEVATION
SCALE: 1/4" = 1'-0"

OWNER:
ALBACORE PARK
BUILDING COMMITTEE
ALBACORE PARK
PORTSMOUTH, NH
ARCHITECT:
PORTONE ARCHITECTS
959 Islington Street
Portsmouth, NH 03801
603.436.8891
info@portonearchitects.com
CONTRACTOR:

CIVIL / STRUCTURAL ENGINEER:
MEPFP ENGINEER:

Revision History		
#	Date	Issuance

SEAL
SCHEMATIC DESIGN
USE DISCLAIMER:
COPYRIGHT © BY PORT ONE ARCHITECTS, INC. 2023
NO RE-USE WITHOUT PERMISSION.
LOCUS MAP

PROJECT NAME:
ALBACORE PARK
WELCOME CENTER
ADDITION &
RENOVATIONS
DRAWING TITLE:
EXTERIOR
ELEVATIONS
PROJECT No: 23-041
DATE: Nov. 7, 2023
DRAWING SCALE: As indicated
DRAWING No: