



PORTSMOUTH, NEW HAMPSHIRE

PLANS FOR THE CONSTRUCTION OF SOUTH MILL POND TENNIS COURTS AND LEARY BALL FIELD LIGHTING



PLANS FOR CONSTRUCTION

SHEET INDEX

C0.00.....	COVER
L0.00.....	GENERAL NOTES AND ABBREVIATIONS
L1.01.....	EXISTING CONDITIONS OVERALL SITE PLAN
L2.01.....	TENNIS COURTS SITE PREPARATION PLAN
L2.02.....	LEARY BALL FIELD LIGHTING SITE PREPARATION PLAN
L3.01.....	TENNIS COURTS LAYOUT AND MATERIALS PLAN
L3.02.....	LEARY BALL FIELD LIGHTING PLAN
L4.01.....	TENNIS COURTS GRADING, DRAINAGE AND UTILITIES PLAN
L5.01.....	CONSTRUCTION DETAILS
L5.02.....	CONSTRUCTION DETAILS
L5.03.....	CONSTRUCTION DETAILS
L5.04.....	CONSTRUCTION DETAILS
L5.05.....	CONSTRUCTION DETAILS
EL1.00.....	ELECTRICAL LEGEND, ABBREVIATIONS, GENERAL NOTES AND DETAILS
EL1.01.....	ELECTRICAL SITE EXISTING CONDITIONS / DEMOLITION PLAN
EL1.02.....	ELECTRICAL SITE NEW WORK PLAN AND PHOTOMETRIC PLAN

Locus Map

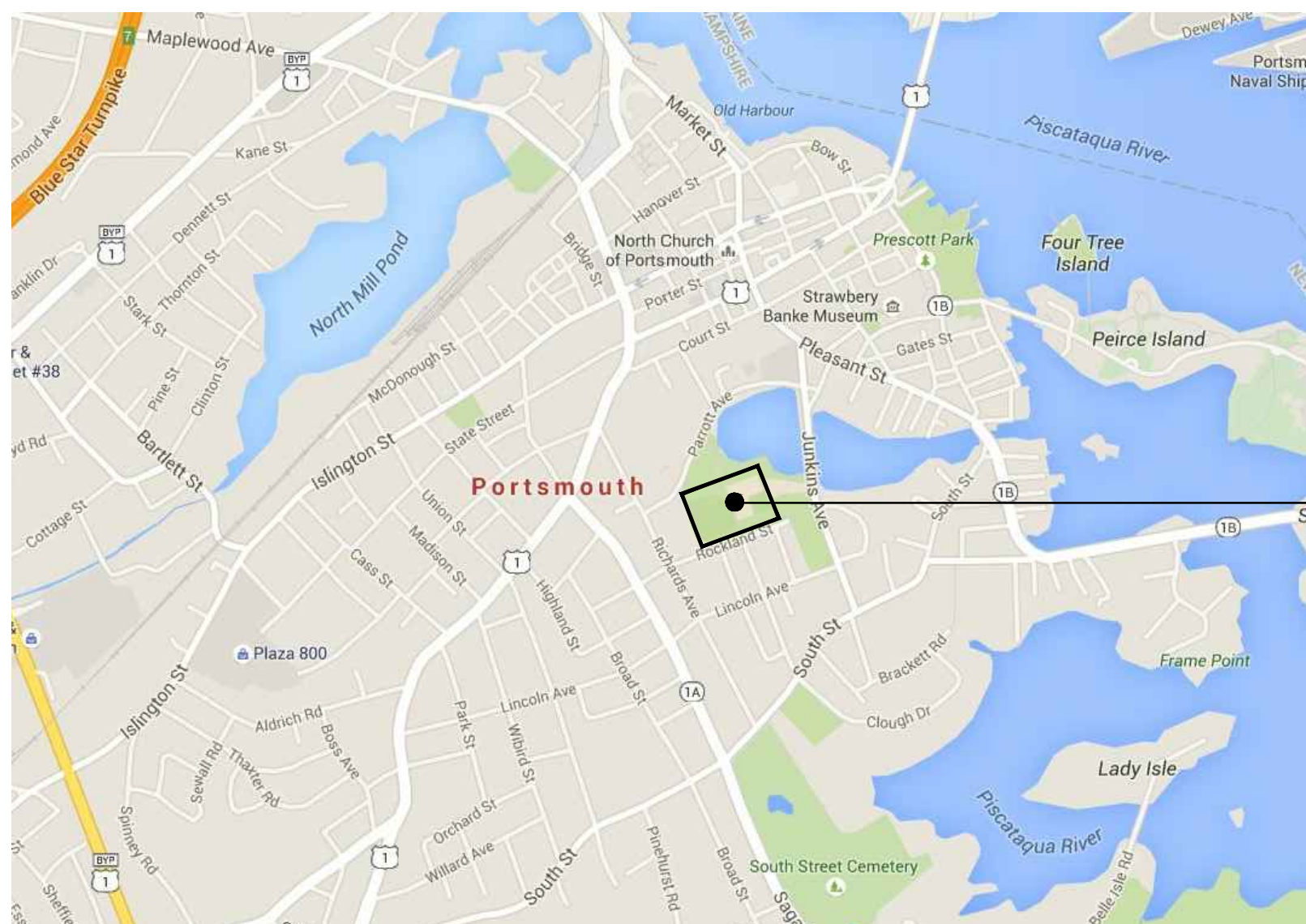

SOUTH MILL POND TENNIS COURTS
AND LEARY BALL FIELD

Rockland Street
Portsmouth, New Hampshire

SEPTEMBER, 2015

Prepared By

Weston & Sampson



Weston & Sampson
427 Main Street, Suite 400, Worcester, MA
(978) 532-1900 (800) Sampson
www.westonandsampson.com

GENERAL NOTES

- PROPERTY LINES, SITE SURVEY AND TOPOGRAPHICAL INFORMATION BASED ON THE GROUND SURVEY PERFORMED BY DOUCET SURVEY JANUARY 21, 2015. HORIZONTAL DATUM BASED ON NEW HAMPSHIRE STATE PLANE (2800) NAD83 (CORS98). VERTICAL DATUM IS BASED ON NAVD88.
- ALL BIDDERS ARE REQUIRED TO INSPECT THE PROJECT SITE PRIOR TO SUBMITTING THEIR BID, AND BECOME FAMILIAR WITH ALL CONDITIONS AS THEY MAY AFFECT THEIR BID. CONTRACTOR AND SUB-CONTRACTOR SHALL BE FAMILIAR WITH ALL DRAWINGS AND SPECIFICATIONS PRIOR TO COMMENCING THE CONSTRUCTION.
- LOCATIONS OF ANY UTILITIES SHOWN ON THESE PLANS ARE APPROXIMATE ONLY. CONTRACTOR SHALL BE RESPONSIBLE FOR VERIFYING THE LOCATION OF SUCH UTILITIES, PROTECTING ALL EXISTING UTILITIES AND REPAIRING ANY DAMAGE DONE DURING CONSTRUCTION. THE CONTRACTOR SHALL BE RESPONSIBLE FOR ALL ON-SITE COORDINATION WITH UTILITY COMPANIES AND PUBLIC AGENCIES AND FOR OBTAINING ALL REQUIRED PERMITS AND PAYING ALL REQUIRED FEES. IN ACCORDANCE WITH M.G.L. CHAPTER 82, SECTION 40, INCLUDING AMENDMENTS, CONTRACTORS SHALL NOTIFY ALL UTILITY COMPANIES AND GOVERNMENT AGENCIES IN WRITING PRIOR TO EXCAVATION. CONTRACTOR SHALL ALSO CALL "DIG SAFE" AT (888) 344-7233 NO LESS THAN 72 HOURS, (EXCLUSIVE OF WEEKENDS AND HOLIDAYS), PRIOR TO SUCH EXCAVATION. DOCUMENTATION OF REQUESTS SHALL BE PROVIDED TO PROJECT REPRESENTATIVE PRIOR TO EXCAVATION WORK.
- WHERE AN EXISTING UTILITY IS FOUND TO CONFLICT WITH THE PROPOSED WORK, THE LOCATION, ELEVATION AND SIZE OF THE UTILITY SHALL BE ACCURATELY DETERMINED WITHOUT DELAY BY THE CONTRACTOR AND THE INFORMATION FURNISHED TO THE OWNER'S REPRESENTATIVE FOR RESOLUTION OF THE CONFLICT.
- THE CONTRACTOR SHALL MAKE ALL ARRANGEMENTS FOR THE ALTERATION AND ADJUSTMENT OF GAS, ELECTRIC, TELEPHONE AND ANY OTHER PRIVATE UTILITIES BY THE UTILITY OWNER AT NO ADDITIONAL COST TO THE CITY OF PORTSMOUTH.
- CONTRACTOR SHALL BE RESPONSIBLE FOR REVIEWING ALL DRAWINGS AND SPECIFICATIONS TO DETERMINE THE EXTENT OF EXCAVATION AND DEMOLITION REQUIRED TO RECEIVE SITE IMPROVEMENTS.
- ANY DISCREPANCIES OR CONFLICTS BETWEEN THE DRAWINGS AND EXISTING CONDITIONS, EXISTING CONDITIONS TO REMAIN, TEMPORARY CONSTRUCTION, PERMANENT CONSTRUCTION AND WORK OF ADJACENT CONTRACTS SHALL BE BROUGHT TO THE ATTENTION OF THE OWNER BEFORE PROCEEDING. ITEMS ENCOUNTERED IN AREAS OF EXCAVATION THAT ARE NOT INDICATED ON THE DRAWINGS, BUT ARE VISIBLE ON SURFACE, SHALL BE THE CONTRACTOR'S RESPONSIBILITY AND SHALL BE REMOVED AT NO ADDITIONAL COST TO THE OWNER.
- ANY ALTERATIONS TO THESE DRAWINGS MADE IN THE FIELD DURING CONSTRUCTION SHALL BE RECORDED BY THE GENERAL CONTRACTOR ON "AS-BUILT" DRAWINGS.
- ALL AREAS DISTURBED BY THE CONTRACTOR'S OPERATIONS OUTSIDE THE PROJECT LIMITS, SHALL BE RESTORED TO THE ORIGINAL CONDITION BY THE CONTRACTOR AT NO ADDITIONAL COST AND TO THE SATISFACTION OF THE OWNER.
- ALL WORK SHOWN ON THE PLANS AS BOLD SHALL REPRESENT PROPOSED WORK. THE TERM "PROPOSED (PROP)" INDICATES WORK TO BE CONSTRUCTED USING NEW MATERIALS OR, WHERE APPLICABLE, RE-USING EXISTING MATERIALS IDENTIFIED AS "REMOVE AND SALVAGE (R&S)", OR REMOVE, RELOCATE, SALVAGE, (R,R&S).
- ALL KNOWN EXISTING STATE, COUNTY AND CITY LOCATION LINES AND PRIVATE PROPERTY LINES HAVE BEEN ESTABLISHED FROM AVAILABLE INFORMATION AND ARE INDICATED ON THE PLANS.
- THE CONTRACTOR SHALL TAKE ALL NECESSARY PRECAUTIONS TO PROTECT HIS EMPLOYEES, AS WELL AS PUBLIC USERS FROM INJURY DURING THE ENTIRE CONSTRUCTION PERIOD USING ALL NECESSARY SAFEGUARDS, INCLUDING BUT NOT LIMITED TO, THE ERECTION OF TEMPORARY WALKS, STRUCTURES, PROTECTIVE BARRIERS, COVERING, OR FENCES AS NEEDED.
- THE CONTRACTOR SHALL SUPPLY THE OWNER WITH THE NAME OF THE OSHA "COMPETENT PERSON" PRIOR TO CONSTRUCTION.
- FILLING OF EXCAVATED AREAS SHALL NOT TAKE PLACE WITHOUT THE PRESENCE OR PERMISSION OF THE OWNER.
- EXISTING TREES TO REMAIN SHALL BE PROTECTED FROM CONSTRUCTION ACTIVITIES. NO STOCKPILING OF MATERIAL, EQUIPMENT OR VEHICULAR TRAFFIC SHALL BE ALLOWED WITHIN THE DRIP LINE OF TREES TO REMAIN. NO GUYS SHALL BE ATTACHED TO ANY TREE TO REMAIN. WHEN NECESSARY OR AS DIRECTED BY THE ENGINEER, THE CONTRACTOR SHALL ERECT TEMPORARY BARRIERS FOR THE PROTECTION OF EXISTING TREES DURING CONSTRUCTION.
- TREES AND SHRUBS WITHIN THE LIMITS OF WORK SHALL BE REMOVED ONLY UPON THE APPROVAL OF THE LANDSCAPE ARCHITECT OR AS NOTED ON THE PLANS.
- NO FILLING SHALL OCCUR AROUND EXISTING TREES TO REMAIN WITHOUT THE APPROVAL OF THE OWNER OR OWNER REPRESENTATIVE.
- THE CONTRACTOR SHALL REMOVE ALL SURFACE VEGETATION PRIOR TO GRADING THE SITE. TREES AND STUMPS SHALL BE REMOVED AND DISPOSED COMPLETE BY CONTRACTOR. TEMPORARY EROSION CONTROL MEASURES SHOWN ON THE DRAWINGS (INCLUDING SILT FENCE, STRAW WATTLES, OR SILT SOCKS) SHALL BE INSTALLED BY THE CONTRACTOR. THE CONTRACTOR SHALL BE RESPONSIBLE FOR MAINTAINING THESE TEMPORARY EROSION CONTROL MEASURES THROUGHOUT THE PROJECT WHICH COST SHALL BE INCIDENTAL TO THE PROJECT.
- ALL UNSUITABLE UNCONTAMINATED EXCESS SOIL FROM CONSTRUCTION ACTIVITIES SHALL BE DISPOSED OF BY THE CONTRACTOR AT NO ADDITIONAL COST TO THE CITY. REMOVAL ACTIVITIES SHALL BE IN ACCORDANCE WITH STATE AND LOCAL REGULATIONS AT NO ADDITIONAL COST TO THE CITY. SUITABLE SOIL EXCAVATION AS PART OF THE PROJECT MUST MEET ONE OR MORE OF THE MATERIAL REQUIREMENTS SPECIFIED. ON-SITE FILL MATERIALS, WHICH DO NOT CONFORM TO THE SPECIFICATIONS, SHALL NOT BE USED BELOW ANY STRUCTURES. IF THE CONTRACTOR PROPOSES TO USE THE EXISTING FILL ON SITE BELOW PAVEMENT AREAS, HE MUST DEMONSTRATE THAT THE FILL MEETS THE REQUIREMENTS PER THE SPECIFICATIONS. ALL EXCAVATED FILL MATERIAL WHICH DOES NOT MEET THE REQUIREMENTS OF THE CONTRACT DOCUMENTS SHALL BE REMOVED AND DISPOSED OF OFF-SITE AT NO ADDITIONAL COST.
- CONTRACTOR IS RESPONSIBLE FOR STAKING CONSTRUCTION BASELINES IN FIELD WITH A NEW HAMPSHIRE REGISTERED PROFESSIONAL LAND SURVEYOR. NO CONSTRUCTION WILL BE PERFORMED WITHOUT THE PROPOSED BASELINES AND LAYOUTS APPROVED BY THE ENGINEER.
- NO FILL SHALL CONTAIN HAZARDOUS MATERIALS.
- CONTRACTOR SHALL PROVIDE TEMPORARY FENCING AROUND PERIMETER OF WORK AREA (LIMIT OF WORK). FENCE SHALL NOT IMPEDE TRAVEL WAYS.
- ANY QUANTITIES SHOWN ON PLANS ARE FOR COMPARATIVE BIDDING PURPOSES ONLY. IT IS THE CONTRACTOR'S RESPONSIBILITY TO VISIT THE PROJECT SITE TO VERIFY ALL QUANTITIES AND CONDITIONS PRIOR TO SUBMITTING BID AND NOTIFY OWNER/ ENGINEER.
- ALL EXISTING DRAINAGE FACILITIES TO REMAIN SHALL BE MAINTAINED FREE OF DEBRIS, SOIL, SEDIMENT, AND FOREIGN MATERIAL AND OPERATIONAL THROUGHOUT THE LIFE OF THE CONTRACT. REMOVE ALL SOIL, SEDIMENT, DEBRIS AND FOREIGN MATERIAL FROM ALL DRAINAGE STRUCTURES, INCLUDING BUT NOT LIMITED TO, DRAINAGE INLETS, MANHOLES AND CATCH BASINS WITHIN THE LIMIT OF WORK AND DRAINAGE STRUCTURES OUTSIDE THE LIMIT OF WORK THAT ARE IMPACTED BY THE WORK FOR THE ENTIRE DURATION OF CONSTRUCTION.
- CONTRACTOR'S STAGING AREA MUST BE WITHIN THE CONTRACT LIMIT LINE AND IN AREAS APPROVED BY OWNER. ANY OTHER AREAS THAT THE CONTRACTOR MAY WISH TO USE FOR STAGING MUST BE COORDINATED WITH THE OWNER.
- THE CONTRACTOR SHALL KEEP ALL STREETS, PARKING LOTS AND WALKS THAT ARE NOT RESTRICTED FROM PUBLIC USE DURING CONSTRUCTION BROOM CLEAN AT ALL TIMES. THE CONTRACTOR SHALL USE ACCEPTABLE METHODS AND MATERIALS TO MAINTAIN ADEQUATE DUST CONTROL THROUGHOUT CONSTRUCTION.

- CONTRACTOR SHALL COORDINATE ALL WORK WITH THE OWNER.
- CONTRACTOR SHALL DEWATER AS NECESSARY TO PERFORM THE PROPOSED WORK. CONTRACTOR SHALL BE AWARE OF PERCHED GROUNDWATER.
- THE LIMIT OF WORK SHALL BE DELINEATED IN THE FIELD PRIOR TO THE START OF SITE CLEARING OR CONSTRUCTION AND AGREED UPON WITH THE LANDSCAPE ARCHITECT.
- DEEP SUMP CATCH BASINS AND STORMWATER BASIN SHALL BE CLEANED FOLLOWING CONSTRUCTION AND SHALL FOLLOW THE OPERATION AND MAINTENANCE PLAN THEREAFTER.
- HAULING OF EARTH MATERIALS TO AND FROM THE SITE SHALL BE RESTRICTED TO THE HOURS OF 7 AM TO 6 PM.
- ANY BOULDERS 3 CY OR SMALLER SHALL BE CONSIDERED UNDOCUMENTED FILL AND SHALL BE DISPOSED OF AT NO ADDITIONAL COST TO THE CITY.
- WORK ON SATURDAYS SHALL ONLY BE CONDUCTED IF PRIOR WRITTEN PERMISSION IS PROVIDED BY THE CITY.
- NO TRUCKS LEFT IDLING ON CITY STREETS DURING CONSTRUCTION. CONSTRUCTION TRAFFIC AT NO TIME SHALL IMPEDE FLOW OF RESIDENT TRAFFIC.

EROSION AND SEDIMENT CONTROL NOTES

- ALL SEDIMENT AND EROSION CONTROL DEVICES SHALL BE PUT INTO PLACE PRIOR TO BEGINNING ANY CONSTRUCTION OR DEMOLITION. REFER TO PLANS FOR APPROXIMATE LOCATION OF EROSION AND SEDIMENT CONTROL. REFER TO SPECS AND DETAILS FOR TYPE OF EROSION AND SEDIMENT CONTROL.
- THE CONTRACTOR SHALL BE RESPONSIBLE FOR THE CONTINUAL MAINTENANCE OF ALL CONTROL DEVICES THROUGHOUT THE DURATION OF THE PROJECT.
- CONTRACTOR SHALL MEET ALL OF THE STATE OF NEW HAMPSHIRE D.E.P. AND THE CITY OF PORTSMOUTH WETLAND ORDINANCE REGULATIONS FOR SEDIMENT AND EROSION CONTROL.
- EXCAVATED MATERIAL STOCKPILED ON THE SITE SHALL BE SURROUNDED BY A RING OF UNBROKEN SEDIMENT AND EROSION CONTROL FENCE. THE LIMITS OF ALL GRADING AND DISTURBANCE SHALL BE KEPT TO A MINIMUM WITHIN THE APPROVED AREA OF CONSTRUCTION. ALL AREAS OUTSIDE OF THE LIMIT OF CONTRACT SHALL REMAIN TOTALLY UNDISTURBED UNLESS OTHERWISE APPROVED BY OWNERS REPRESENTATIVE.
- ALL CATCH BASINS AND DRAIN GRATES WITHIN LIMIT OF CONTRACT SHALL BE PROTECTED WITH SILT SACKS DURING THE ENTIRE DURATION OF CONSTRUCTION.
- EROSION CONTROL BARRIERS TO BE INSTALLED AT THE TOE OF SLOPES. SEE GRADING & DRAINAGE PLANS, NOTES, DETAILS AND SPECIFICATIONS.
- THE CONTRACTOR SHALL PROVIDE DUST CONTROL FOR CONSTRUCTION OPERATIONS AS REQUIRED BY OWNER.
- ALL POINTS OF CONSTRUCTION EGRESS OR INGRESS SHALL BE MAINTAINED AND CONTRACTOR MUST PROVIDE A TIRE WASH TO PREVENT TRACKING OR FLOWING OF SEDIMENT ON TO PUBLIC/Private ROADS. TIRE WASH TO USED UPON EXITING THE SITE.

DEMOLITION & SITE PREPARATION NOTES

- THE CONTRACTOR SHALL INCLUDE IN THE BID THE COST OF REMOVING ANY EXISTING SITE FEATURES AND APPURTENANCES NECESSARY TO ACCOMPLISH THE CONSTRUCTION OF THE PROPOSED SITE IMPROVEMENTS. THE CONTRACTOR SHALL ALSO INCLUDE IN THE BID THE COST NECESSARY TO RESTORE SUCH ITEMS IF THEY ARE SCHEDULED TO REMAIN AS PART OF THE FINAL SITE IMPROVEMENTS. REFER TO PLANS TO DETERMINE EXCAVATION, DEMOLITION AND TO DETERMINE THE LOCATION OF THE PROPOSED SITE IMPROVEMENTS.
- THE OWNER RESERVES THE RIGHT TO REVIEW ALL MATERIALS DESIGNATED FOR REMOVAL AND TO RETAIN OWNERSHIP OF SUCH MATERIALS. IF THE OWNER RETAINS ANY MATERIAL THE CONTRACTOR SHALL MAKE ARRANGEMENTS WITH THE OWNER TO HAVE THOSE MATERIALS REMOVED OFF SITE AT NO ADDITIONAL COST.
- UNLESS SPECIFICALLY NOTED TO BE REMOVED / SALVAGED (R&S), ALL SITE FEATURES CALLED FOR REMOVAL (REM) SHALL BE REMOVED WITH THEIR FOOTINGS, ATTACHMENTS, BASE MATERIAL, ETC. TRANSPORTED FROM THE SITE TO BE DISPOSED OF IN A LAWFUL MANNER AT AN ACCEPTABLE DISPOSAL SITE AND AT NO ADDITIONAL COST TO THE OWNER.
- ALL EXISTING SITE FEATURES TO REMAIN SHALL BE PROTECTED THROUGHOUT THE CONSTRUCTION PERIOD. ANY FEATURES DAMAGED DURING CONSTRUCTION OPERATIONS SHALL BE REPAIRED OR REPLACED TO THE SATISFACTION OF THE OWNER'S REPRESENTATIVE AT NO ADDITIONAL COST.
- DURING EARTHWORK OPERATIONS, CONTRACTOR SHALL TAKE CARE TO NOT DISTURB EXISTING MATERIALS TO REMAIN, OUTSIDE THE LIMITS OF EXCAVATION AND BACKFILL AND SHALL TAKE WHATEVER MEASURES NECESSARY, AT THE CONTRACTOR'S EXPENSE, TO PREVENT ANY EXCAVATED MATERIAL FROM COLLAPSING. ALL BACKFILL MATERIALS SHALL BE PLACED AND COMPACTED AS SPECIFIED TO THE SUBGRADE REQUIRED FOR THE INSTALLATION OF THE REMAINDER OF THE CONTRACT WORK.
- IT SHALL BE THE CONTRACTOR'S OPTION, WITH CONCURRENCE OF THE OWNER, TO REUSE EXISTING GRAVEL IF IT MEETS THE REQUIREMENTS OF THE SPECIFICATIONS FOR GRAVEL BORROW.
- "STRIP AND REMOVE TURF" SHALL INCLUDE REMOVAL OF GRASS, SHRUBS, AND UNDERBRUSH. REMOVAL OF ROOTS, ROUGH GRADING, INSTALLATION OF LOAM (IF APPLICABLE), FINE GRADING, SEEDING AND TURF ESTABLISHMENT BY THE CONTRACTOR.
- TREES DESIGNATED FOR REMOVAL SHALL BE TAGGED BY CONTRACTOR AND APPROVED BY OWNER'S REPRESENTATIVE PRIOR TO COMMENCEMENT OF CONSTRUCTION.
- THE STORAGE OF MATERIALS AND EQUIPMENT WILL BE PERMITTED AT LOCATIONS DESIGNATED BY OWNER OR OWNER'S REPRESENTATIVE. PROTECTION OF STORED MATERIALS AND EQUIPMENT SHALL BE THE SOLE RESPONSIBILITY OF THE CONTRACTOR.
- LOAM / TOP SOIL DESIGNATED FOR REUSE AS GENERAL FILL SHALL BE BLENDED WITH SUITABLE BORROW MATERIAL AS SPECIFIED.
- THE CONTRACTOR SHALL PROTECT EXISTING TREES TO REMAIN, CONTRACTOR SHALL INSTALL TREE PROTECTION BARRIER AFTER CLEARING UNDERBRUSH AND TAKE DUE CARE TO PREVENT INJURY TO TREES DURING CLEARING OPERATIONS.

LAYOUT & MATERIALS NOTES

- REFER TO EXISTING CONDITIONS PLANS FOR SURVEY INFORMATION (SHEET L1.01).
- COORDINATE ALL LAYOUT ACTIVITIES WITH THE SCOPE OF WORK CALLED FOR BY DEMOLITION, GRADING AND UTILITIES OPERATIONS ENCOMPASSED BY THIS CONTRACT. SET, PROTECT AND REPLACE REFERENCE STAKES AS NECESSARY OR AS REQUIRED BY THE OWNER'S REPRESENTATIVE.
- ALL WORK SHALL BE PERFORMED BY CONTRACTOR UNLESS SPECIFICALLY INDICATED THAT THE WORK WILL BE PERFORMED "BY OTHERS" OR "UNDER SEPARATE CONTRACT".
- TO FACILITATE LAYOUT OF PROPOSED SITE FEATURES AND FACILITIES, LAYOUT INFORMATION FOR CERTAIN FUTURE WORK, WHICH IS NOT INCLUDED WITHIN THE SCOPE OF THIS CONTRACT HAS BEEN PROVIDED ON THE LAYOUT AND MATERIALS PLAN FOR INFORMATION ONLY. SOME ITEMS ARE "NOT IN CONTRACT" (NIC) AND SHOWN FOR REFERENCE ONLY.
- THE LAYOUT OF SITE AMENITIES AND FENCES MUST BE APPROVED BY THE LANDSCAPE ARCHITECT PRIOR TO INSTALLATION.
- THE LAYOUT OF ALL NEW PATHWAYS / WALKWAYS AND THE GRADING OF ALL SLOPES AND CROSS SLOPES SHALL CONFORM TO THE NEW HAMPSHIRE RULES AND REGULATIONS FOR HANDICAP ACCESS CMR 521, AND THE AMERICANS WITH DISABILITIES ACT (ADA), TITLE 3. THE CONTRACTOR SHALL NOTIFY THE OWNER IMMEDIATELY OF ANY DISCREPANCIES BETWEEN ACTUAL CONDITIONS AND THOSE REQUIRED.
- ALL LAYOUT LINES, OFFSETS, OR REFERENCES TO LOCATING OBJECTS ARE EITHER PARALLEL OR PERPENDICULAR UNLESS OTHERWISE DESIGNATED WITH ANGLE OFFSETS NOTED.
- ALL PROPOSED SITE FEATURES SHALL BE LAID OUT AND STAKED FOR REVIEW AND APPROVAL BY THE OWNER'S REPRESENTATIVE PRIOR TO COMMENCEMENT OF INSTALLATION. ANY REQUIRED ADJUSTMENTS TO THE LAYOUT SHALL BE UNDERTAKEN AS DIRECTED, AT NO ADDITIONAL COST TO THE OWNER. ALL LAYOUT SHALL BE PERFORMED BY A NH REGISTERED PROFESSIONAL LAND SURVEYOR.
- ALL PROPOSED PAVEMENTS SHALL MEET THE LINE AND GRADE OF EXISTING ADJACENT PAVEMENT SURFACES. ALL BITUMINOUS CONCRETE SHALL BE TREATED WITH AN RS-1 TACK COAT AT POINT OF CONNECTION. ALL PATHWAY WIDTHS SHALL BE AS NOTED ON THE LAYOUT AND MATERIALS PLAN.
- THE CONTRACTOR SHALL VERIFY ALL DIMENSIONS AND GRADES ON THE GROUND AND REPORT ANY DISCREPANCIES IMMEDIATELY TO THE OWNER.
- THE CONTRACTOR SHALL BE RESPONSIBLE FOR FIELD MEASUREMENT OF ALL PROPOSED FENCES AND GATES.
- THE DEPTH OF LOAM BORROW FOR ALL PROPOSED LAWN AREAS SHALL BE 6" MINIMUM. ALL DISTURBED AREAS SHALL BE RESTORED WITH LOAM AND SEED AND MULCH UNLESS OTHERWISE NOTED
- REFER TO DETAIL DRAWINGS FOR CONSTRUCTION DETAILS.
- SURVEY CONTROL POINTS AND COORDINATES ARE INDICATED ON THE PLANS. IT IS THE RESPONSIBILITY OF THE CONTRACTOR TO PROTECT OR CREATE HIS OWN PROTECTED CONTROL POINTS FROM THIS INFORMATION. THE CONTRACTOR IS RESPONSIBLE FOR ENSURING ALL LAYOUT POINTS ARE CONSISTENT WITH CONTROL INFORMATION. RESETTING OF DAMAGED OR MISSING LAYOUT MARKERS AS NECESSARY IS AT NO ADDITIONAL COST TO THE OWNER.

GRADING, UTILITIES & DRAINAGE NOTES

- ALL WORK RELATING TO INSTALLATION, RENOVATION OR MODIFICATION OF WATER, DRAINAGE AND/OR SEWER SERVICES SHALL BE PERFORMED IN ACCORDANCE WITH THE STANDARDS OF THE CITY OF PORTSMOUTH DPW.
- THE CONTRACTOR SHALL VERIFY ALL DIMENSIONS AND GRADES ON THE GROUND AND REPORT ANY DISCREPANCIES IMMEDIATELY TO THE OWNER.
- ALL GRADING IS TO BE SMOOTH AND CONTINUOUS WHERE PROPOSED SURFACES MEET EXISTING SURFACES, ELIMINATE ROUGH SPOTS AND ABRUPT GRADE CHANGES AND MEET LINE AND GRADE OF EXISTING CONDITIONS WITH NEW IMPROVEMENTS.
- CONTRACTOR SHALL MAINTAIN POSITIVE DRAINAGE (1.5% - 2.0% FOR WALKWAYS)(1.0% MAX FOR PLAY AREAS) AWAY FROM ALL BUILDING FOUNDATIONS AND STRUCTURES.
- CONTRACTOR SHALL ENSURE ALL AREAS ARE PROPERLY PITCHED TO DRAIN, WITH NO SURFACE WATER PONDING OR PUDDLING.
- MINIMUM CROSS SLOPE ON ALL WALKWAYS WILL BE 1:100 OR 1.5% TO PROVIDE POSITIVE DRAINAGE. ANY DISCREPANCIES NOT ALLOWING THIS TO OCCUR SHALL BE REPORTED TO THE OWNER PRIOR TO CONTINUING WORK.
- ALL UTILITY GRATES, COVERS OR OTHER SURFACE ELEMENTS INTENDED TO BE EXPOSED AT GRADE SHALL BE FLUSH WITH THE ADJACENT FINISHED GRADE AND ADJUSTED TO PROVIDE A SMOOTH TRANSITION AT ALL EDGES. ALL UTILITY GRATES WITHIN PLAYING FIELDS OR INDICATED TO BE "BURIED" SHALL BE 4" BELOW FINISH GRADE AND COVERED WITH FINISH MATERIAL INDICATED ON PLANS.
- THE CONTRACTOR SHALL SET SUBGRADE ELEVATIONS TO ALLOW FOR POSITIVE DRAINAGE AND PROVIDE EROSION CONTROL DEVICES, STRUCTURES, MATERIALS AND CONSTRUCTION METHODS TO DIRECT SILT MIGRATION AWAY FROM DRAINAGE AND OTHER UTILITY SYSTEMS, PUBLIC/Private STREETS AND WORK AREAS. CLEAN BASINS REGULARLY AS NEEDED AND AT THE END OF THE PROJECT.
- EXCAVATION REQUIRED WITHIN PROXIMITY OF KNOWN EXISTING UTILITY LINES SHALL BE DONE BY HAND. CONTRACTOR SHALL REPAIR ANY DAMAGE TO EXISTING UTILITY LINES OR STRUCTURES INCURRED DURING CONSTRUCTION OPERATIONS AT NO COST TO THE OWNER.
- WHERE NEW EARTHWORK MEETS EXISTING EARTHWORK, CONTRACTOR SHALL BLEND NEW EARTHWORK SMOOTHLY INTO EXISTING, PROVIDING VERTICAL CURVES OR ROUNDS AT ALL TOP AND BOTTOM OF SLOPES.
- WHERE A SPECIFIC LIMIT OF WORK LINE IS NOT OBVIOUS OR IMPLIED, BLEND GRADES TO EXISTING CONDITIONS WITHIN 5 FEET OF PROPOSED CONTOURS.
- RESTORE ALL DISTURBED AREAS AND LIMITS OF ALL REMOVALS TO LOAM AND SEED (L&S) UNLESS OTHERWISE NOTED.
- SEE EARTHWORK SECTION OF SPECIFICATIONS FOR SPECIFIC EXCAVATION AND FILLING PROCEDURES.
- FOR STRUCTURE REMODELING (REM0D), CONSTRUCTION METHODS SHALL FOLLOW NEW HAMPSHIRE DOT STANDARD SPEC. LATEST EDITION.

ABBREVIATIONS

GENERAL	PROPOSED
PROP	ADJUST
ADJ	BITUMINOUS CONCRETE
BIT. CONC.	CEMENT CONCRETE
B	BASLINE
N.T.S.	NOT TO SCALE
BYCL	BLACK VINYL CHAIN LINK
B.M.	BENCH MARK
ABAN	ABANDON
MB	MAIL BOX
GRAN. CURB	GRANITE CURB
EXIST.	EXISTING
(OR EX.)	FOUNDATION
FDN	
FL	
(OR F)	FLOW LINE
P	PROPERTY LINE
PVMT	PAVEMENT
P.W.W.	PAVED WATERWAY
RC	REINFORCED CONCRETE
M.H.B.	NEW HAMPSHIRE HIGHWAY BOUND
REM	REMOVE
REMOD	REMODEL
RET	RETAIN
R.O.W.	RIGHT-OF-WAY
R&S	REMOVE AND SALVAGE
R&S	REMOVE, RELOCATED AND SALVAGE
R&D	REMOVE AND STACK
SB	REMOVE AND DISPOSE
NIC	STONE BOUND
H.C.	NOT IN CONTRACT
WCR	HANDICAP
FF	WHEELCHAIR RAMP
HMA	FINISHED FLOOR
G.C.	HOT MIX ASPHALT
E.C.	GENERAL CONTRACTOR
P.C.	ELECTRICAL CONTRACTOR
SWEL	PLUMBING CONTRACTOR
BWLL	SOLID WHITE EDGE LINE
SYEL	BROKEN WHITE LANE LINE
SB/DH	SOLID YELLOW EDGE LINE
CLF	STONE BOUND/ DRILL HOLE
TEMP.	CHAIN LINK FENCE
TYP.	TEMPORARY
EQ	TYPICAL
H.C.	EQUIPMENT
EOP	HANDICAP
PROT	EDGE OF PAVEMENT
CTE	PROTECT
RL	CONNECT TO EXISTING
L.O.W.	ROOF LEADER
VIF	LIMIT OF WORK
BWW	VERIFY IN FIELD
	BORDERING VEGETATED WETLAND

UTILITIES

GICI	GUTTER INLET W/ CURB INLET
CBCI	CATCH BASIN W/ CURB INLET
CS	CATCH BASIN
C.I.T.	CHANGE IN TYPE
F&G	FRAME AND GRATE
F&C	FRAME AND COVER
CI	CURB INLET
CIP	CAST IRON PIPE
CMP	CORRUGATED METAL PIPE
DI	DRAIN INLET
GI	GUTTER INLET
ACCM PIPE	ASPHALT COATED CORRUGATED METAL PIPE
HYD	HYDRANT
INV. ELEV.	INVERT ELEVATION
UP	UTILITY POLE
SMH	SEWER MANHOLE
WG	WATER GATE
DS	DOWN SPOUT
HDPE	HIGH DENSITY POLYETHYLENE PIPE
PVC	POLYVINYL CHLORIDE
RCP	REINFORCED CONCRETE PIPE
DMH	DRAIN MANHOLE
LB	LEACHING BASIN
LG	LEACHING GALLEY
CI	CAST IRON
OCS	OUTLET CONTROL STRUCTURE
OGT	OIL AND GRIT TRAP
VC	VITRIFIED CLAY PIPE
LP	LIGHT POLE
OHW	OVERHEAD WIRE
UPLP	UTILITY POLE WITH LIGHT
SWTU	STORM WATER TREATMENT UNIT
HH	HANDHOLE
GW	GARAGE WASTE
CO	CLEANOUT
LC	LEACHING CHAMBER
GV	GATE VALVE
CU	CONNECTION UNKNOWN

ALIGNMENT/GRADING

BW	BOTTOM OF WALL
BC	BOTTOM OF CURB
PI	POINT OF INTERSECTION
PC	POINT OF CURVATURE
PT	POINT OF TANGENCY
PRC	POINT OF REVERSE CURVATURE
PCC	POINT OF COMPOUND CURVATURE
PVI	POINT OF VERTICAL INTERSECTION
PVC	POINT OF VERTICAL CURVATURE
PVT	POINT OF VERTICAL TANGENCY
ELEV	ELEVATION
CC	CENTER OF CURVE
H.P.	HIGH POINT
L.P.	LOW POINT
R	RADIUS OF CURVATURE
STA	STATION
S.S.D.	STOPPING SIGHT DISTANCE
TC	TOP OF CURB
TW	TOP OF WALL

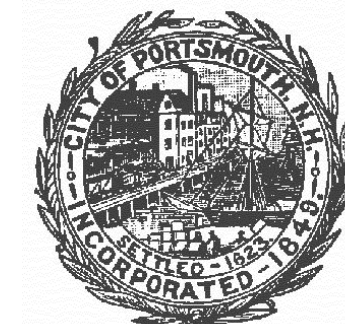
Project:
SOUTH MILL POND TENNIS COURTS

 Rockland Street
 Portsmouth, NH

Weston & Sampson
 427 Main Street, Suite 400, Worcester, MA
 978-532-1900 (900) Sampson
 www.westonandsampson.com

Consultants:

North:

Revisions:

Rev	Date	Description

Seal:

PLANS FOR CONSTRUCTION

Date: 09.18.2015

Scale: N/A

Drawn By: CCC/ EJA

Reviewed By: BK

Checked By: MSM

Approved By:

Drawing Title:

GENERAL NOTES AND ABBREVIATIONS

Sheet Number:

L0.00

LEGEND

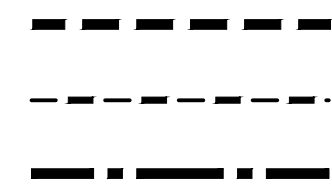

LIMIT OF WORK
 OPTION #2
 OPTION #5

B-5

BORING LOCATION
 #2001
 #2003
 #1994
 #2005
 #2004
 PSNH#0/BW
 W/CONDUIT

**LIGHTING AT LEARY BALL FIELD
 SEE SHEETS L2.02, L3.02, EL1.01, EL1.02**

**TENNIS COURTS IMPROVEMENTS
 SEE SHEETS L2.01, L3.01, L4.01**

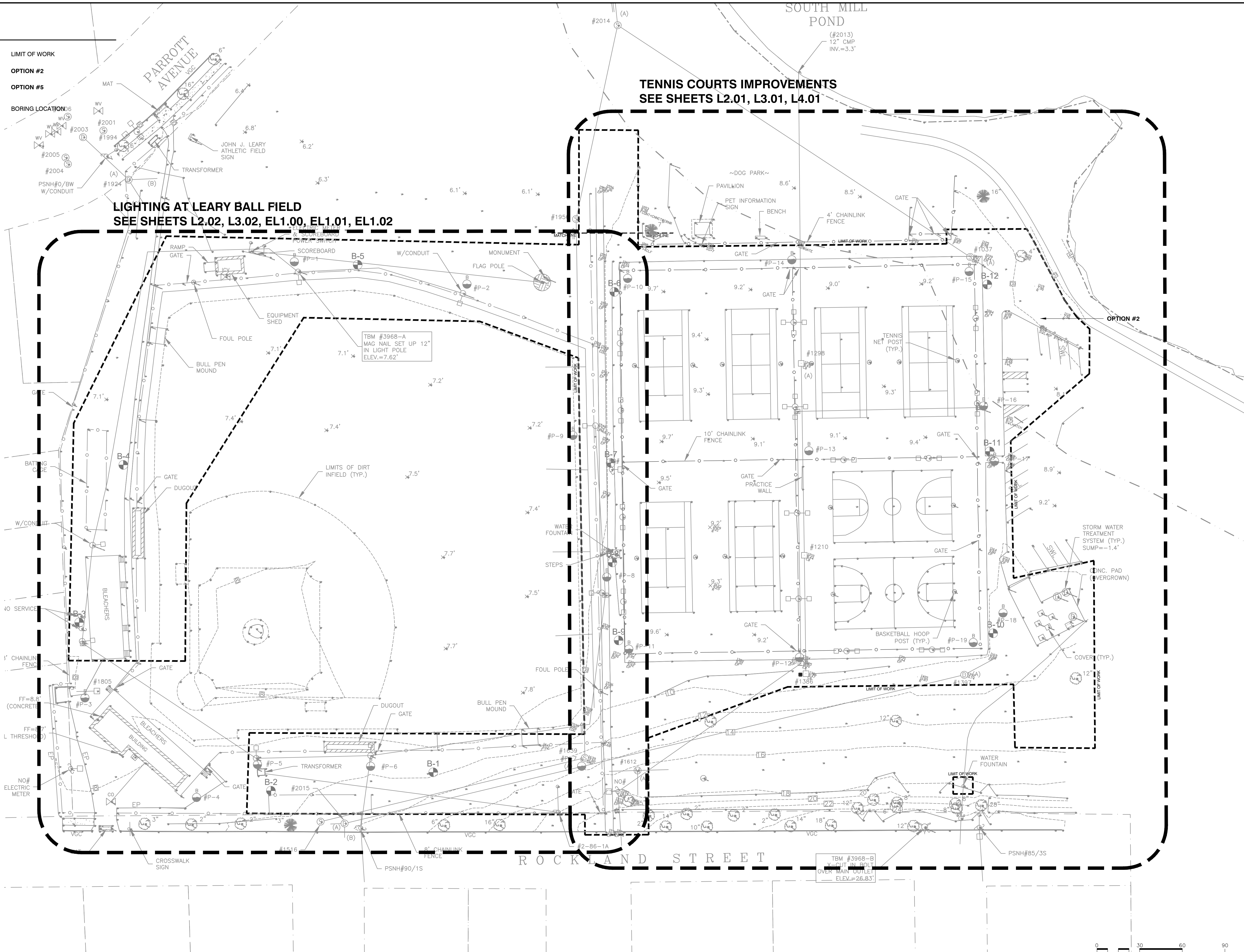

Project:
**SOUTH MILL POND
 TENNIS COURTS**

Rockland Street
 Portsmouth, NH

Weston & Sampson
 427 Main Street, Suite 400, Worcester, MA
 978-832-1900 (800) Sampson
 www.westonandsampson.com

Consultants:

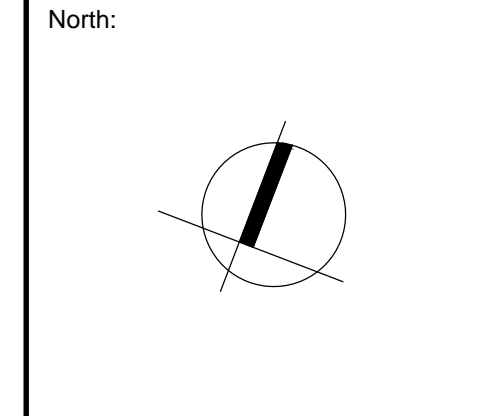

Revisions:

Rev	Date	Description

Seal:

**PLANS FOR
 CONSTRUCTION**







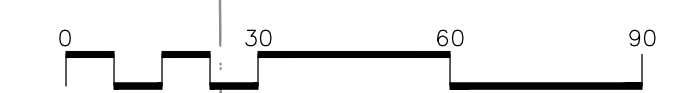





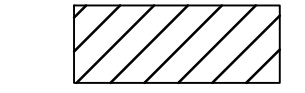
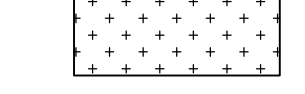

Date: 09.18.2015
 Scale: 1" = 30'
 Drawn By: CCC/ EJA
 Reviewed By: BK
 Checked By: MSM
 Approved By:

Drawing Title:
**EXISTING CONDITIONS
 OVERALL SITE PLAN**

Sheet Number:
L1.01



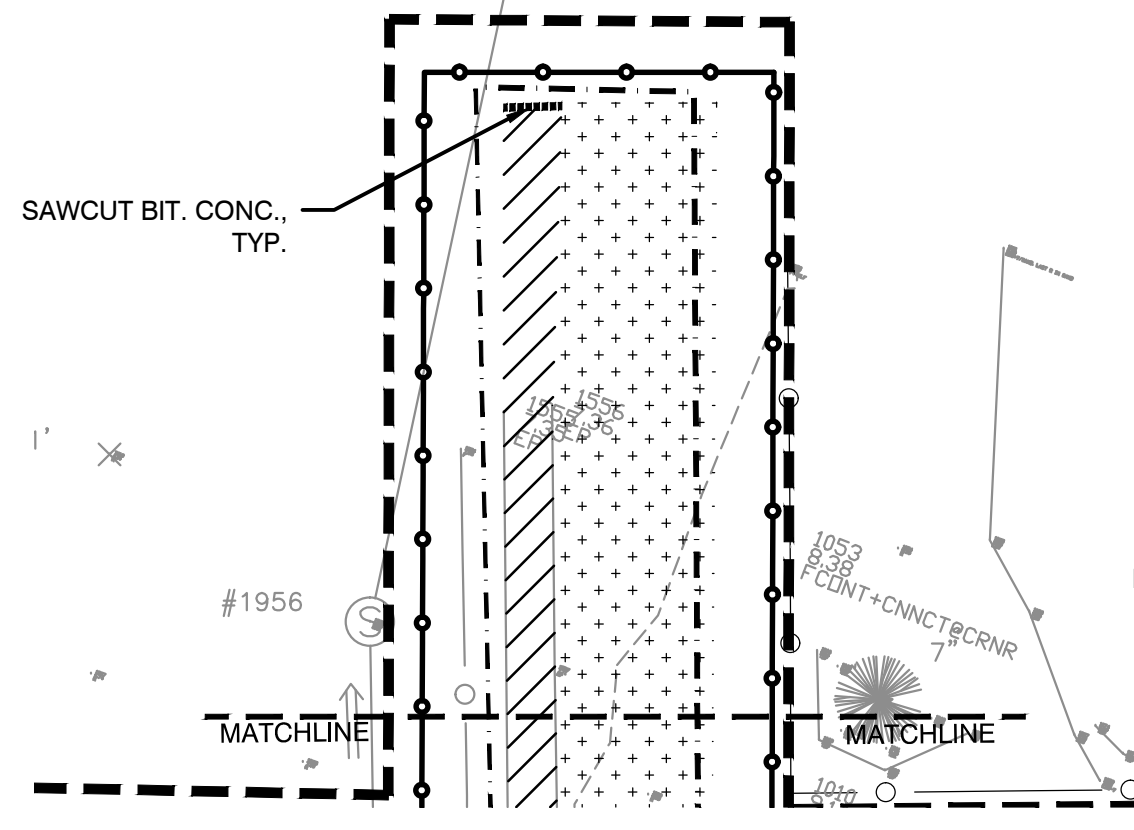

LEGEND

-  LIMIT OF WORK
-  STAGING AREA
-  REMOVE AND DISPOSE BIT. CONC., COMPLETE
-  STRIP AND REMOVE TURF, COMPLETE
-  REMOVE AND DISPOSE FENCE, COMPLETE
-  REMOVE EXISTING PARKING STRIPES
-  REMOVE AND DISPOSE TENNIS FENCE POST AND NET
-  SILTATION AND EROSION CONTROL
-  TEMPORARY CONSTRUCTION FENCE
-  TREE PROTECTION FENCE
-  REMOVE AND DISPOSE LIGHT FIXTURE, POLE AND FOOTING, OR STRUCTURE COMPLETE
-  REMOVE AND SALVAGE WATER FOUNTAIN, COMPLETE (RETURN TO CITY)
-  REMOVE AND DISPOSE TENNIS WALL, COMPLETE
-  REMOVE AND SALVAGE BASKETBALL GOAL OR FOUL POLE
-  SAWCUT BIT. CONC.
-  BORING LOCATION (SEE GEOTECH REPORT)

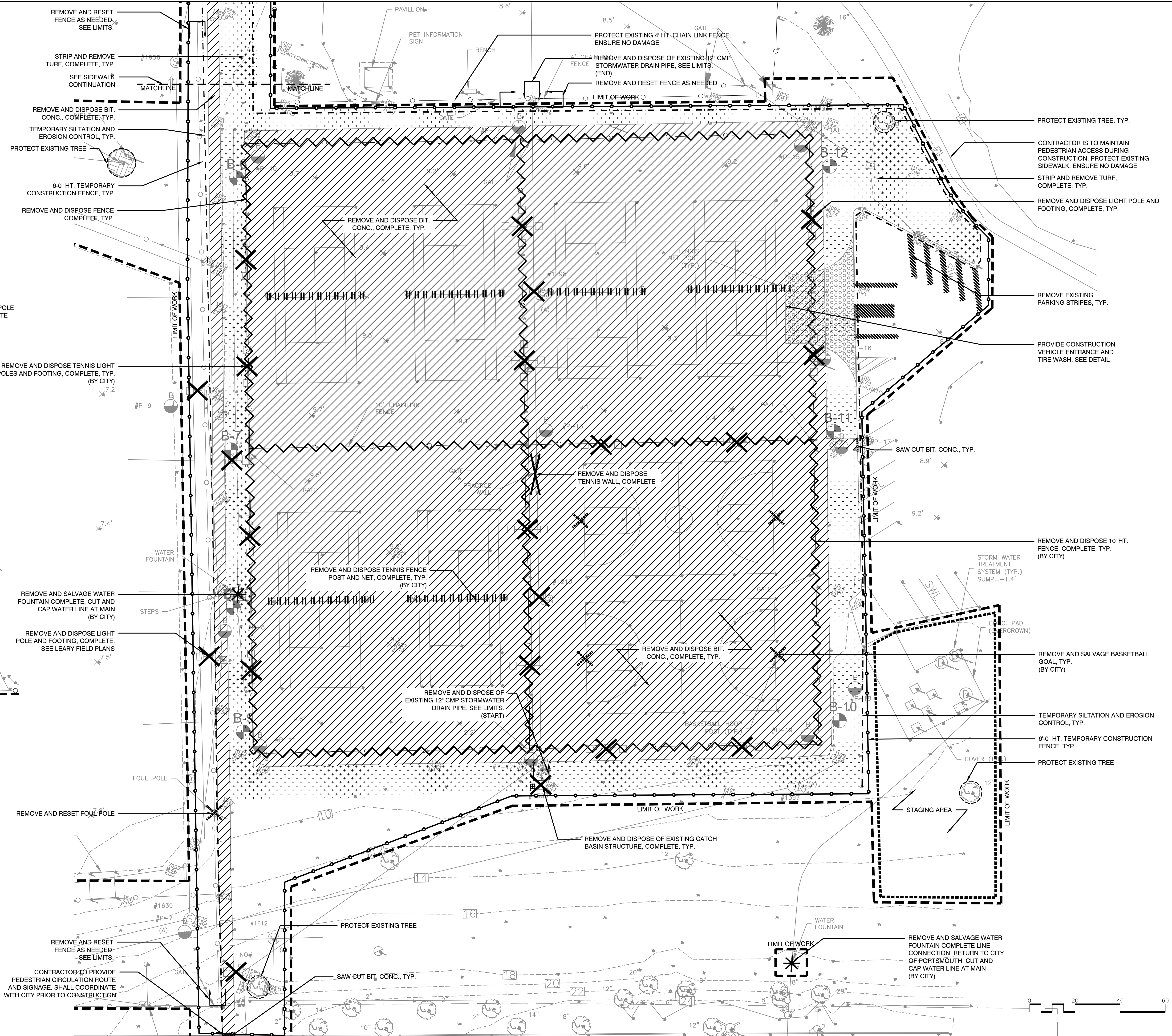

NOTE:
 1. REFER TO ELECTRICAL DRAWINGS FOR ELECTRICAL SITE DEMOLITION.
 2. REMOVE AND RESET EXISTING FENCE AS NEEDED, TO ALLOW ACCESS FOR LIGHTING.



Project:
SOUTH MILL POND TENNIS COURTS

 Rockland Street
 Portsmouth, NH

Weston & Sampson
 427 Main Street, Suite 400, Worcester, MA 01608
 978-532-1900 (800) Sampson
 www.westonandsampson.com

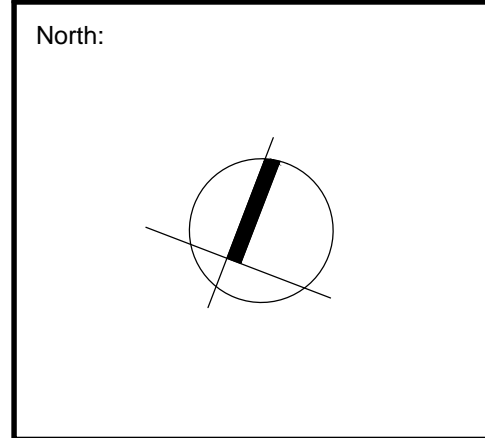
Consultants:



Revisions:

Rev	Date	Description











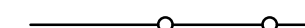

Seal:

PLANS FOR CONSTRUCTION

Date: 09.18.2015
 Scale: 1" = 20'-0"
 Drawn By: CCC/ EJA
 Reviewed By: BK
 Checked By: MSM
 Approved By: _____

Drawing Title:
TENNIS COURTS SITE PREPARATION PLAN
 Sheet Number:
L2.01

LEGEND

-  LIMIT OF WORK
-  OPTION #2
-  OPTION #3
-  TENNIS FENCING
-  TENNIS FENCE GATES
-  HANGING NET DIVIDER
-  STAINLESS STEEL HANDRAIL
-  BIT. CONC. COLOR SEALCOAT, SEE SPECIFICATIONS
-  LOAM AND SEED
-  SPORTS LIGHTING, SEE ELECTRICAL PLANS
-  PEDESTRIAN LIGHTING, SEE ELECTRICAL PLANS
-  NEW DRINKING FOUNTAIN
-  PORTABLE BENCH (TO BE PROVIDED BY THE CITY)

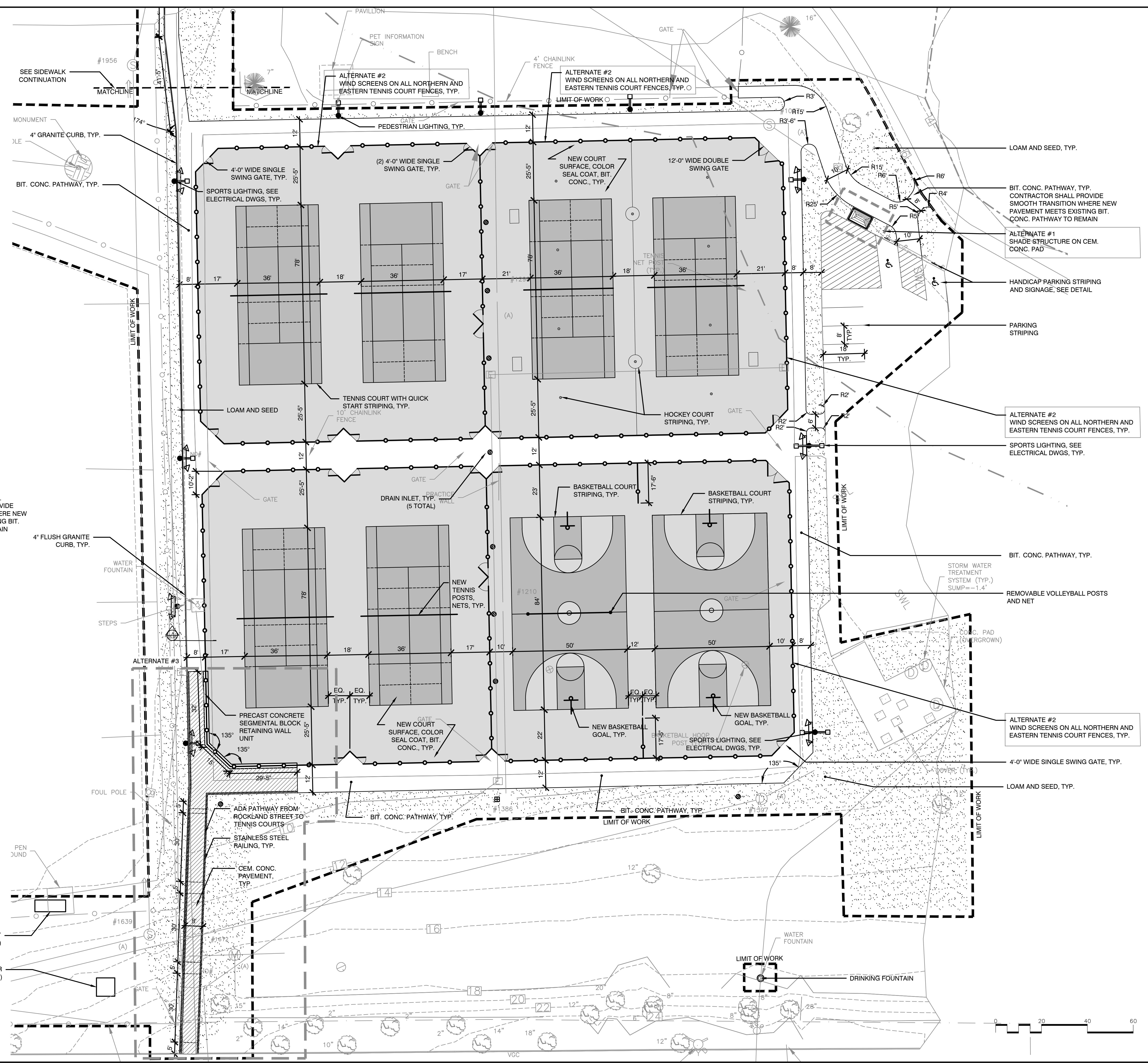
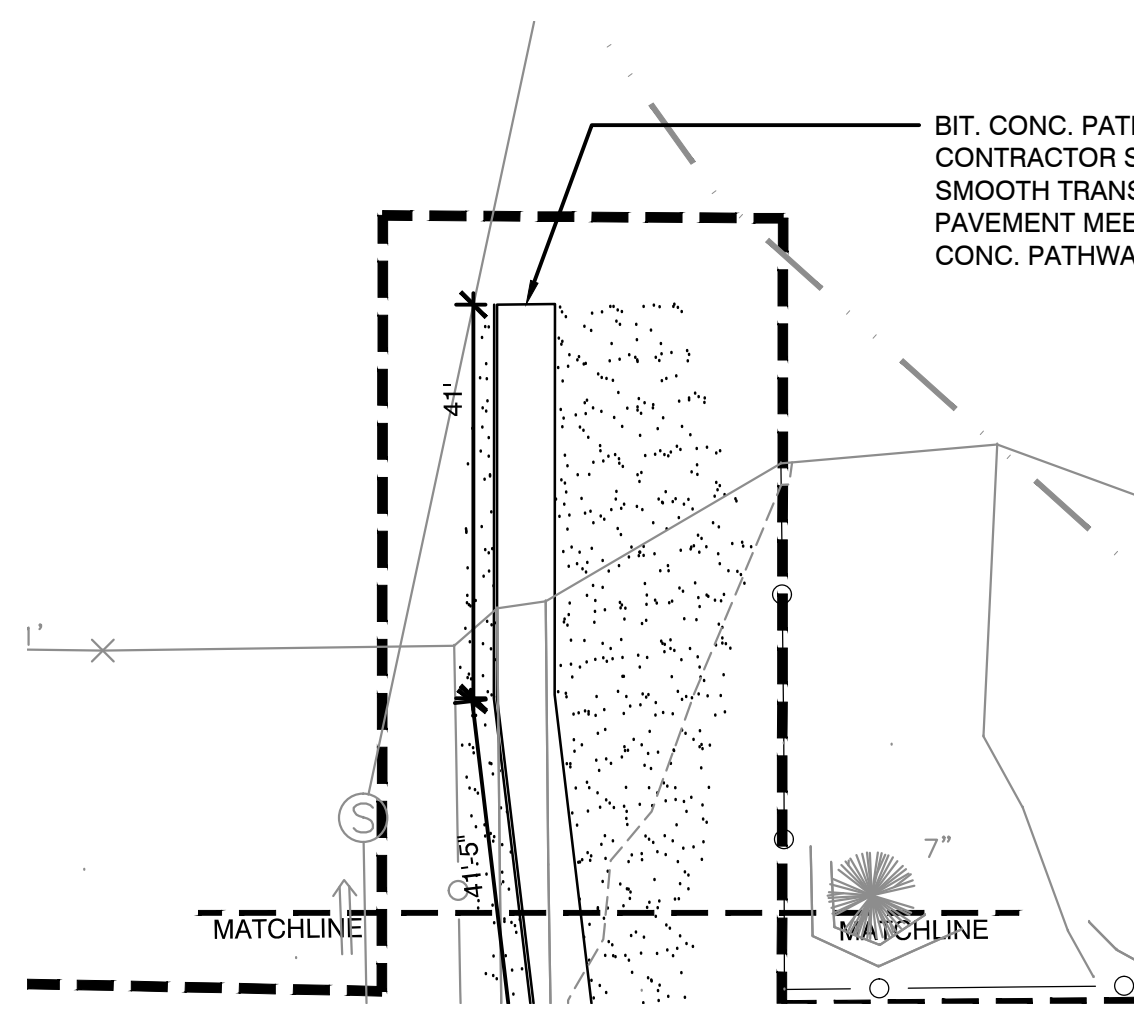

Project:
SOUTH MILL POND TENNIS COURTS

Rockland Street
Portsmouth, NH

Weston & Sampson
427 Main Street, Suite 400, Worcester, MA
978-532-1900 (800) Sampson
www.westonandsampson.com

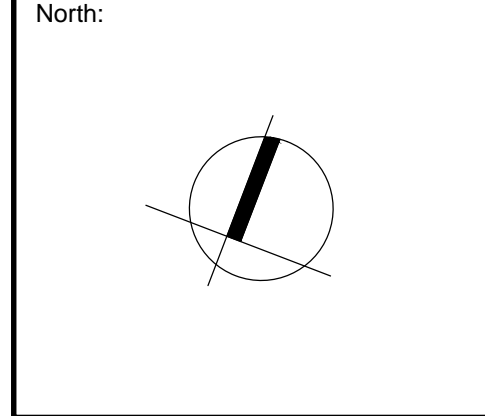
Consultants:



Revisions:

Rev	Date	Description

Seal:

PLANS FOR CONSTRUCTION

Date: 09.18.2015
Scale: 1" = 20'
Drawn By: CCC/EJA
Reviewed By: BK
Checked By: MSM
Approved By:

Drawing Title:
TENNIS COURTS LAYOUT AND MATERIALS PLAN

Sheet Number:
L3.01

LEGEND



SPORTS LIGHTING, SEE ELECTRICAL DWGS, TYP.

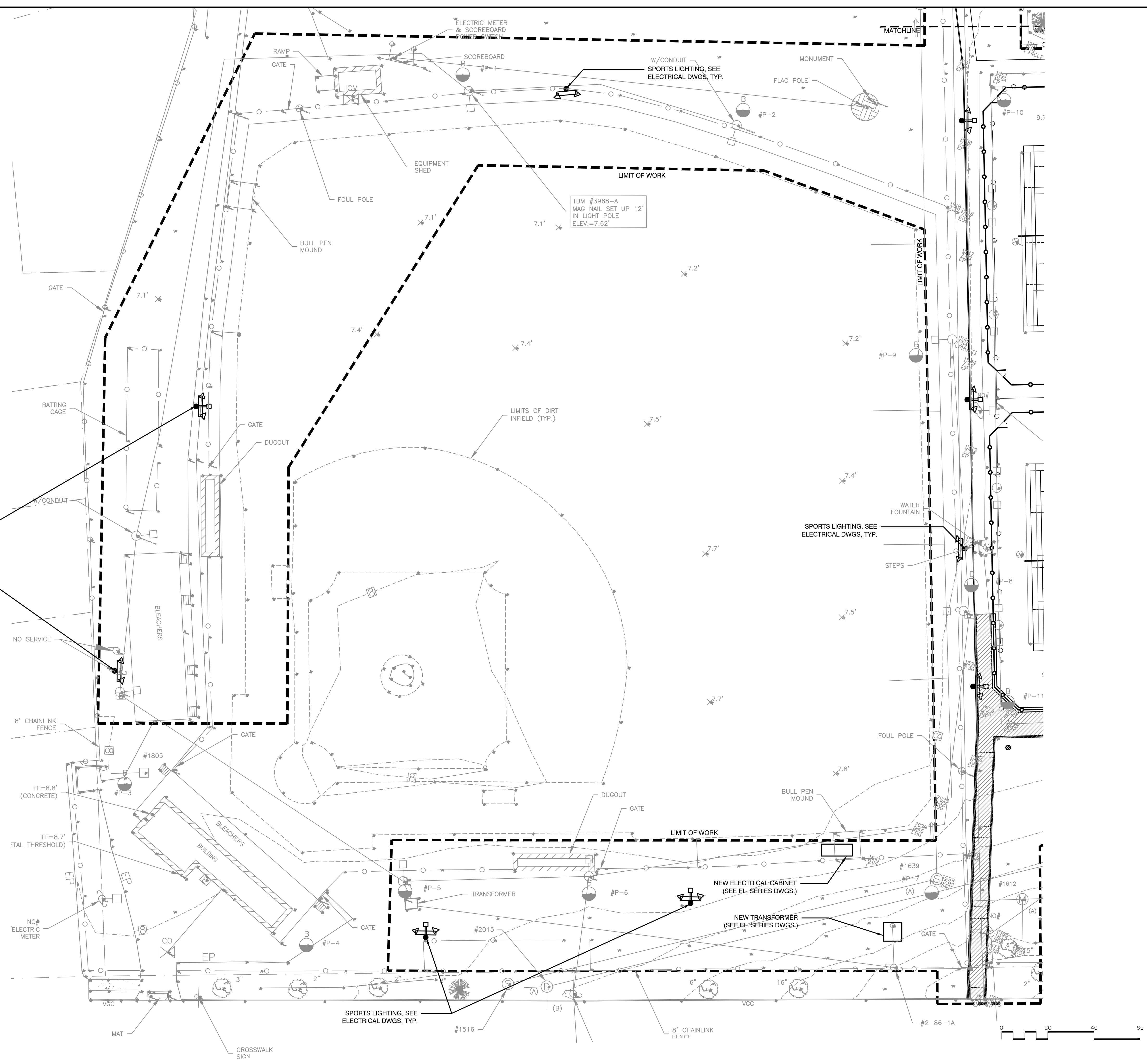

Project:
SOUTH MILL POND TENNIS COURTS

 Rockland Street
 Portsmouth, NH

Weston & Sampson
 427 Main Street, Suite 400, Worcester, MA
 978-652-1900 (800) Sampson
 www.westonandsampson.com

Consultants:

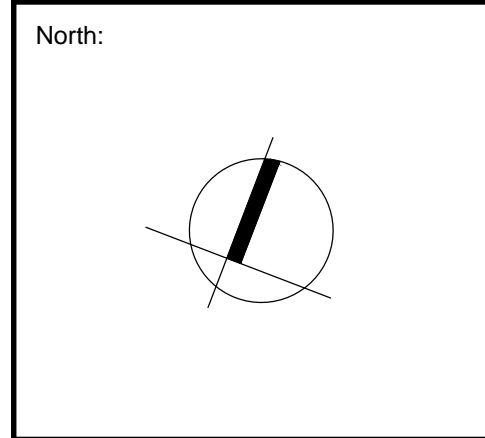

Revisions:

Rev	Date	Description

Seal:





PLANS FOR CONSTRUCTION

Date: 09.18.2015
 Scale: 1" = 20'
 Drawn By: CCC/ EJA
 Reviewed By: BK
 Checked By: MSM
 Approved By:

Drawing Title:
LEARY BALL FIELD LIGHTING PLAN

Sheet Number:
L3.02

LEGEND

-  LIMIT OF WORK
-  EXISTING 2' CONTOUR
-  DRAIN PIPE CONNECTION
-  SPOT GRADE
-  SLOPE PERCENTAGE

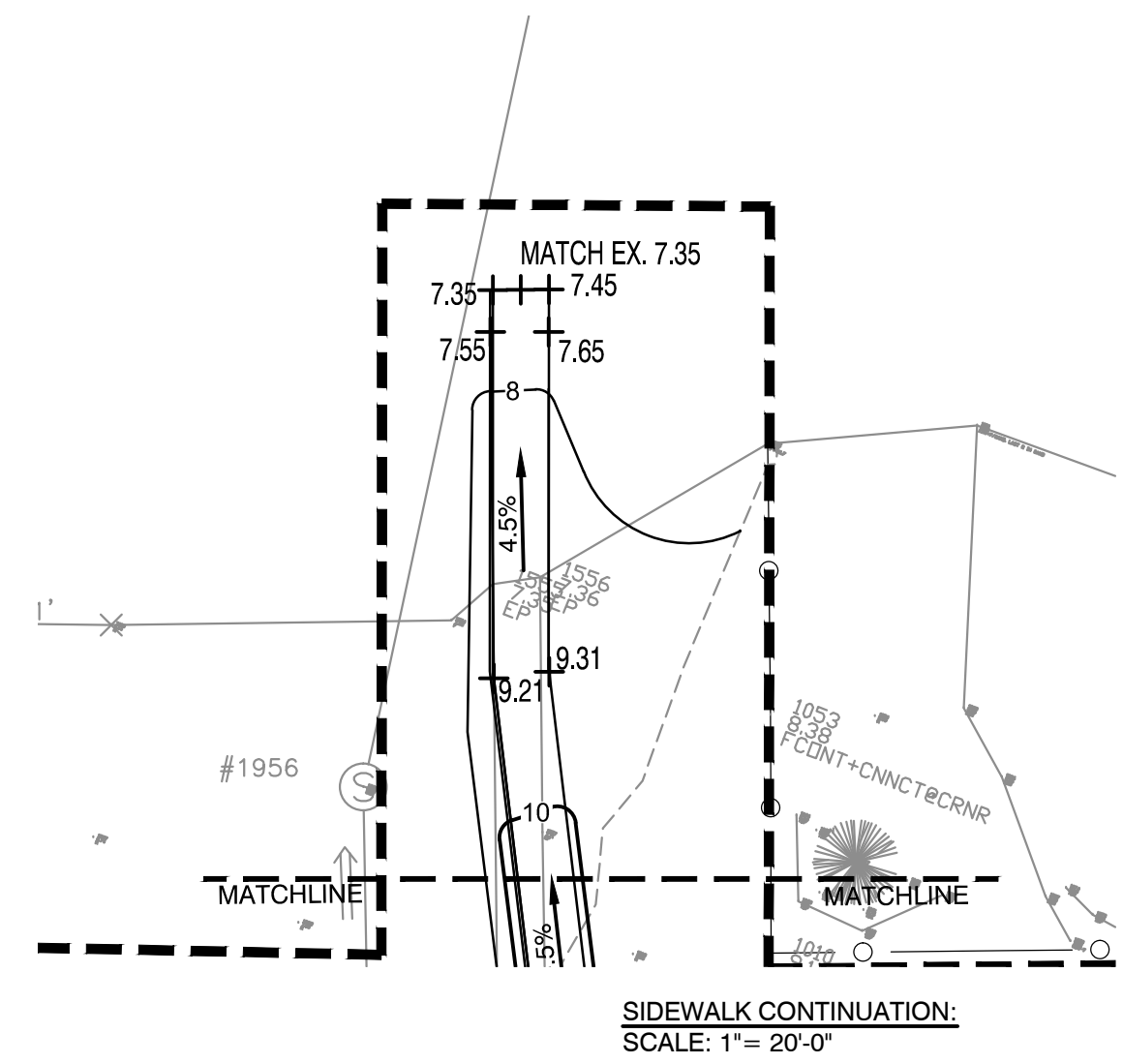

- NOTE:**
1. OPTION #5: RAMP AT 1:12 MAX. SLOPE WITH 30'-0" RUNS AND 5'-0" LANDINGS.
 2. REFER TO ELECTRICAL DRAWINGS FOR NEW ELECTRICAL WORK.

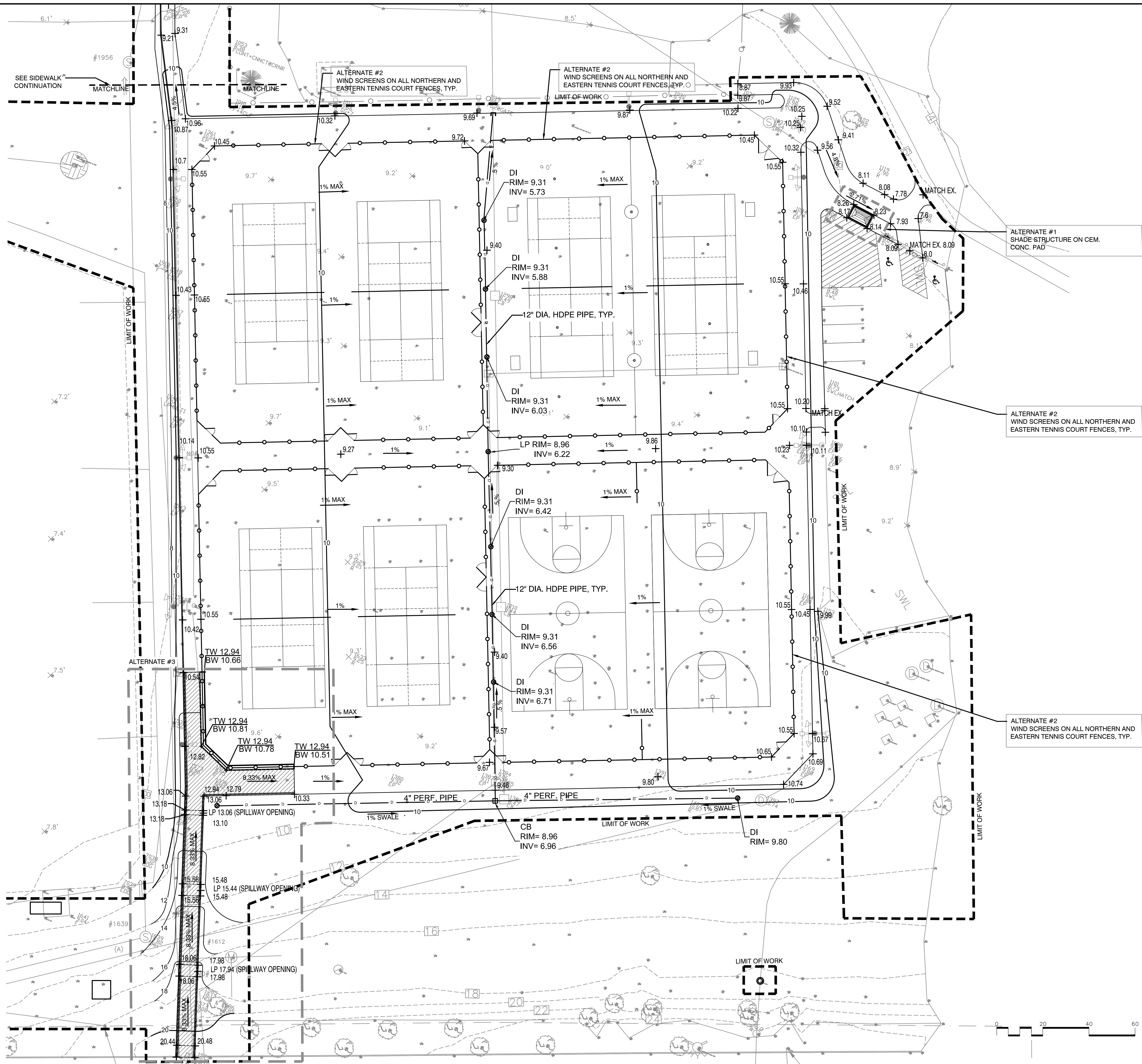

Project:
SOUTH MILL POND TENNIS COURTS

 Rockland Street
 Portsmouth, NH

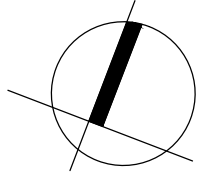
Weston & Sampson
 427 Main Street, Suite 400, Worcester, MA
 978-532-1900 (800) Sampson
 www.westonandsampson.com

Consultants:
 North:

Revisions:

Rev	Date	Description

Seal:

PLANS FOR CONSTRUCTION

Date: 09.18.2015
 Scale: 1" = 20'
 Drawn By: EJA/CCC
 Reviewed By: BK
 Checked By: MSM
 Approved By:

Drawing Title:
TENNIS COURTS GRADING, DRAINAGE AND UTILITIES PLAN

Sheet Number:
L4.01

NOTE:
1. FOR TREES THAT OCCUR IN GROUPS PROVIDE TREE PROTECTION FENCE AROUND ENTIRE AREA. SEE PLAN FOR LOCATIONS.

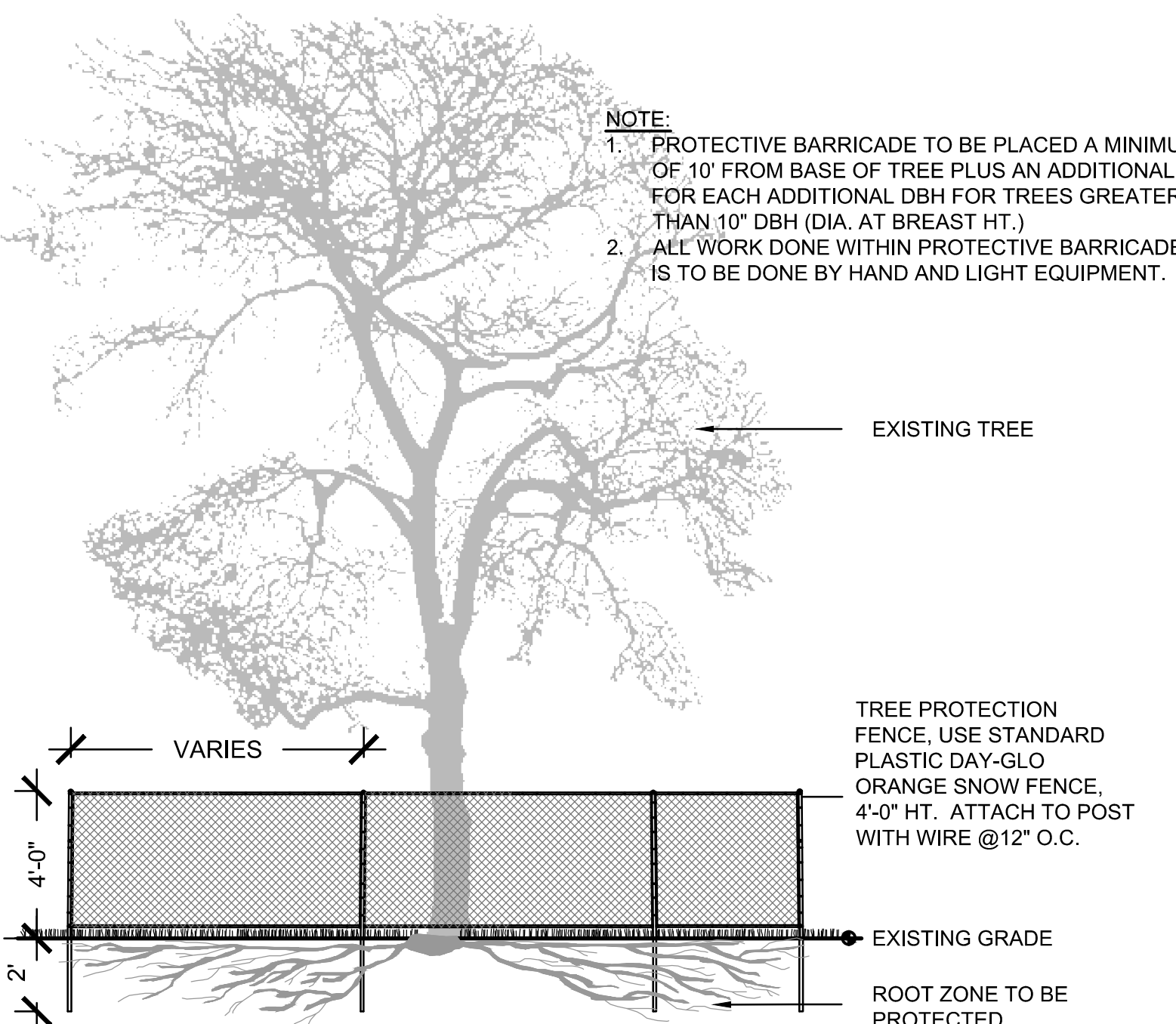
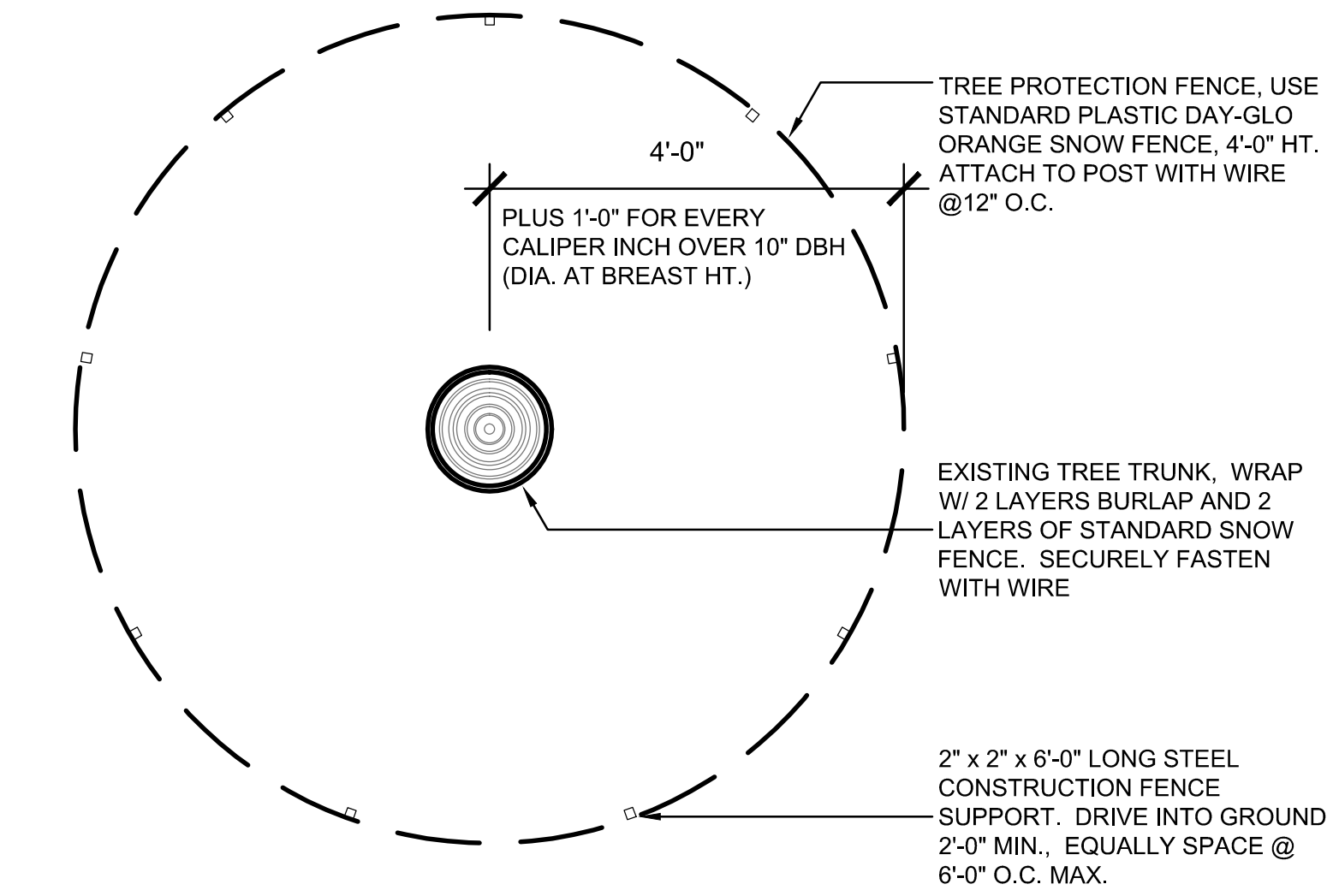

1 TREE PROTECTION FENCE
SCALE: N.T.S.

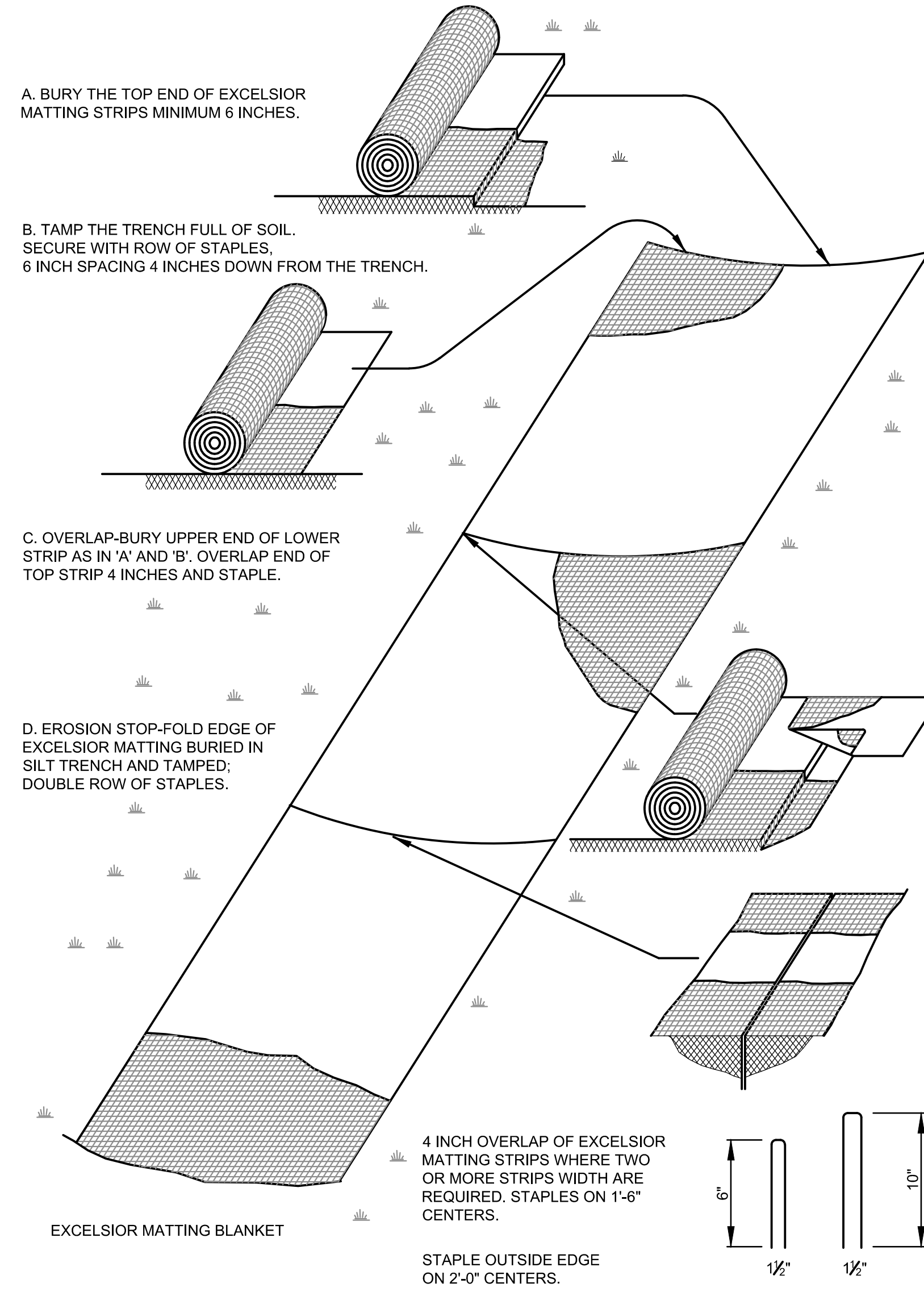

NOTE:
1. JUTE NETTING TO BE USED ON ALL SLOPES GREATER THAN 4H:1V AS INDICATED ON GRADING PLANS

2 EROSION CONTROL BLANKET
SCALE: N.T.S.

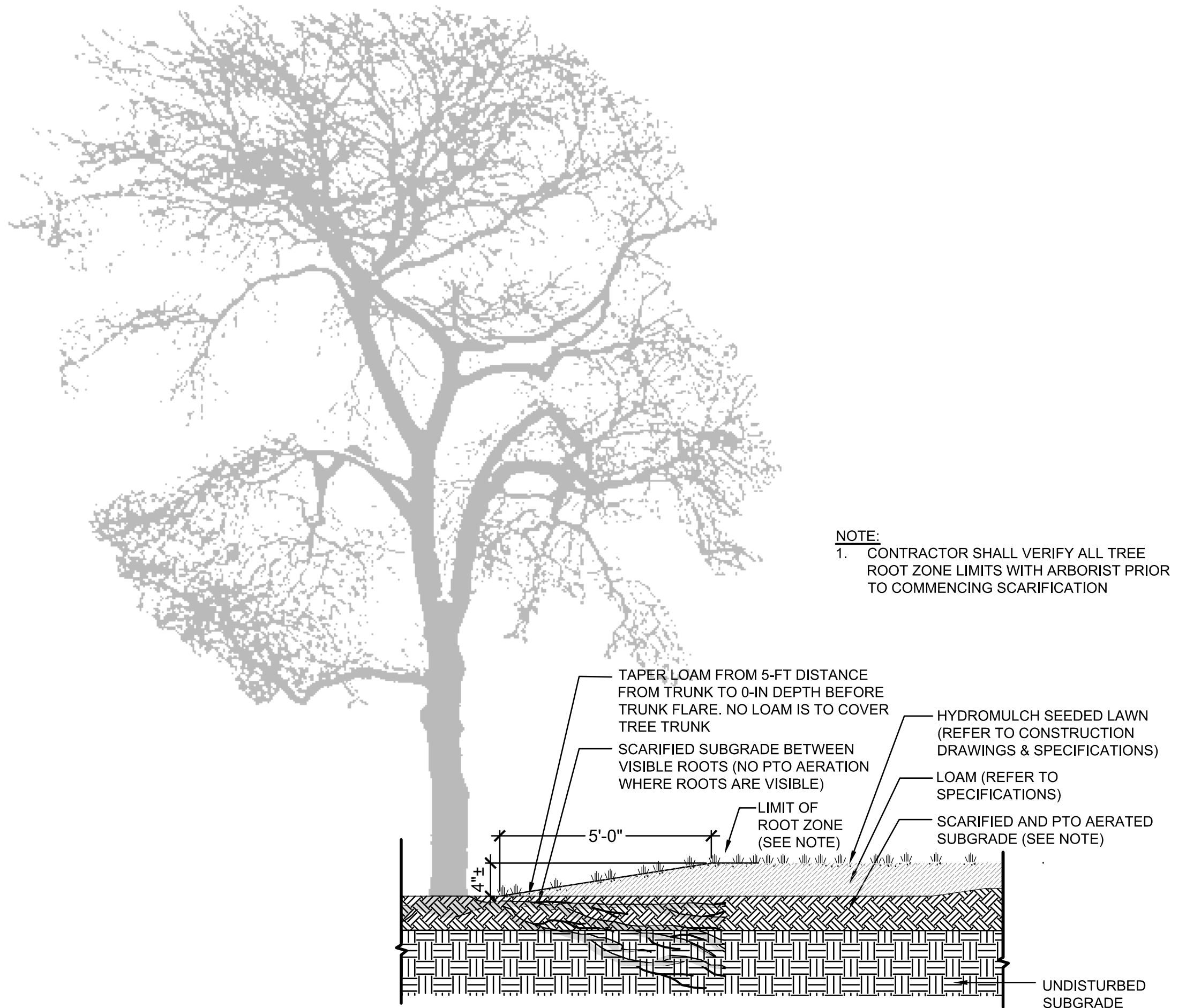

NOTE:
1. CONTRACTOR SHALL VERIFY ALL TREE ROOT ZONE LIMITS WITH ARBORIST PRIOR TO COMMENCING SCARIFICATION

3 LAWN RESTORATION AT EXISTING TREES
SCALE: N.T.S.

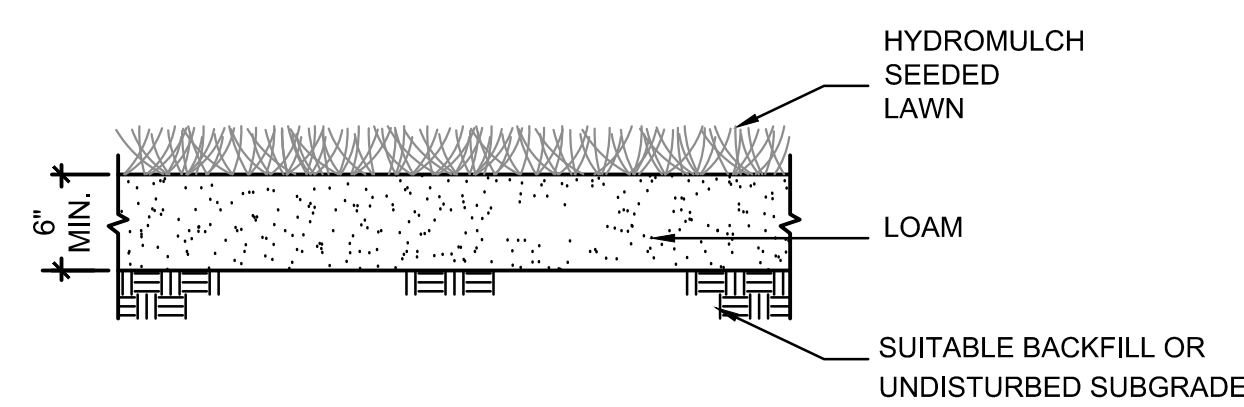

4 LOAM & SEED
SCALE: N.T.S.

Consultants:

North:

Revisions:

Rev	Date	Description

Seal:

PLANS FOR CONSTRUCTION

Date: 09.18.2015
Scale: AS SHOWN
Drawn By: CCC/ EJA
Reviewed By: BK
Checked By: MSM
Approved By:

Drawing Title:
CONSTRUCTION DETAILS

Sheet Number:
L5.01

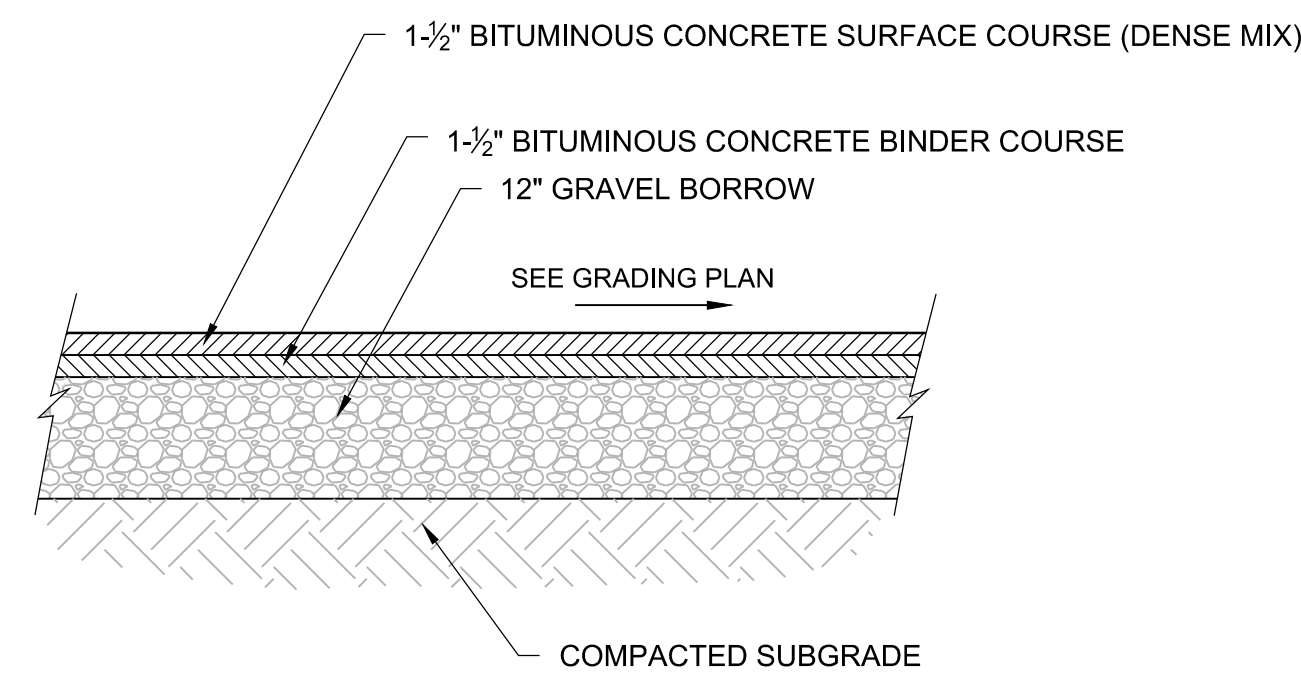

A BITUMINOUS CONCRETE AT TENNIS COURTS
SCALE: N.T.S.

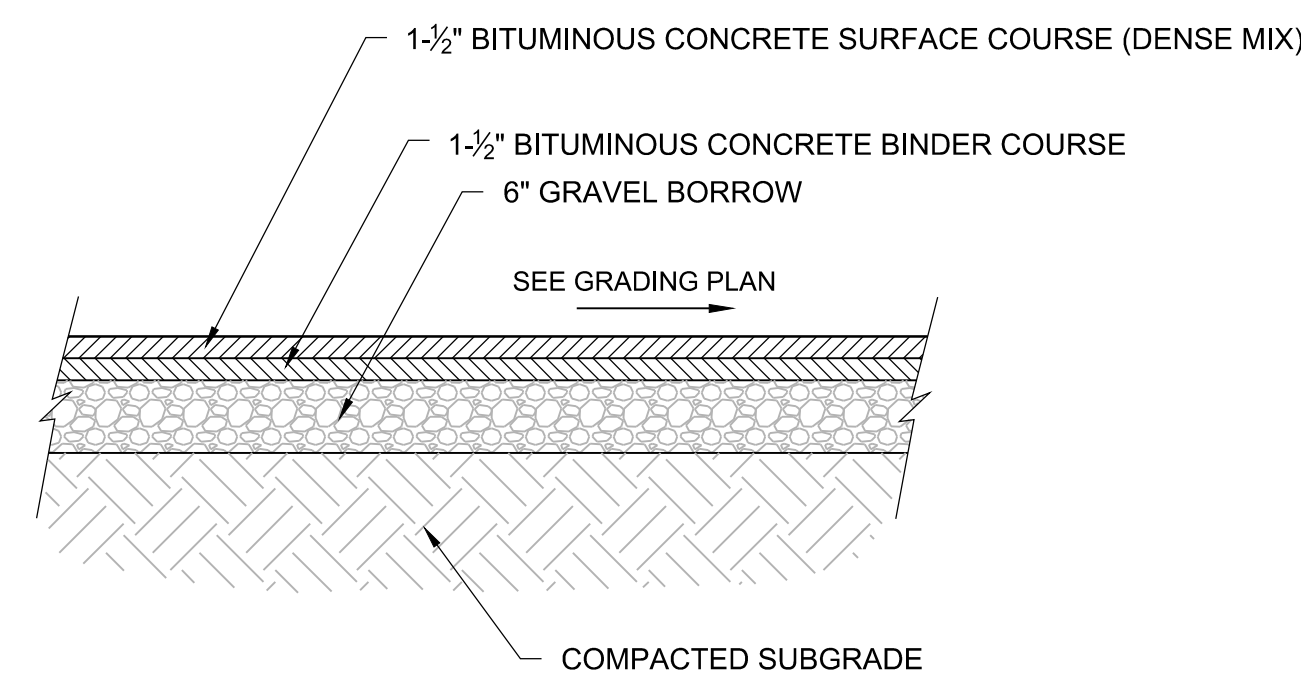

B BITUMINOUS CONCRETE AT PATHWAY
SCALE: N.T.S.

1 BITUMINOUS CONCRETE PAVEMENT
SCALE: N.T.S.

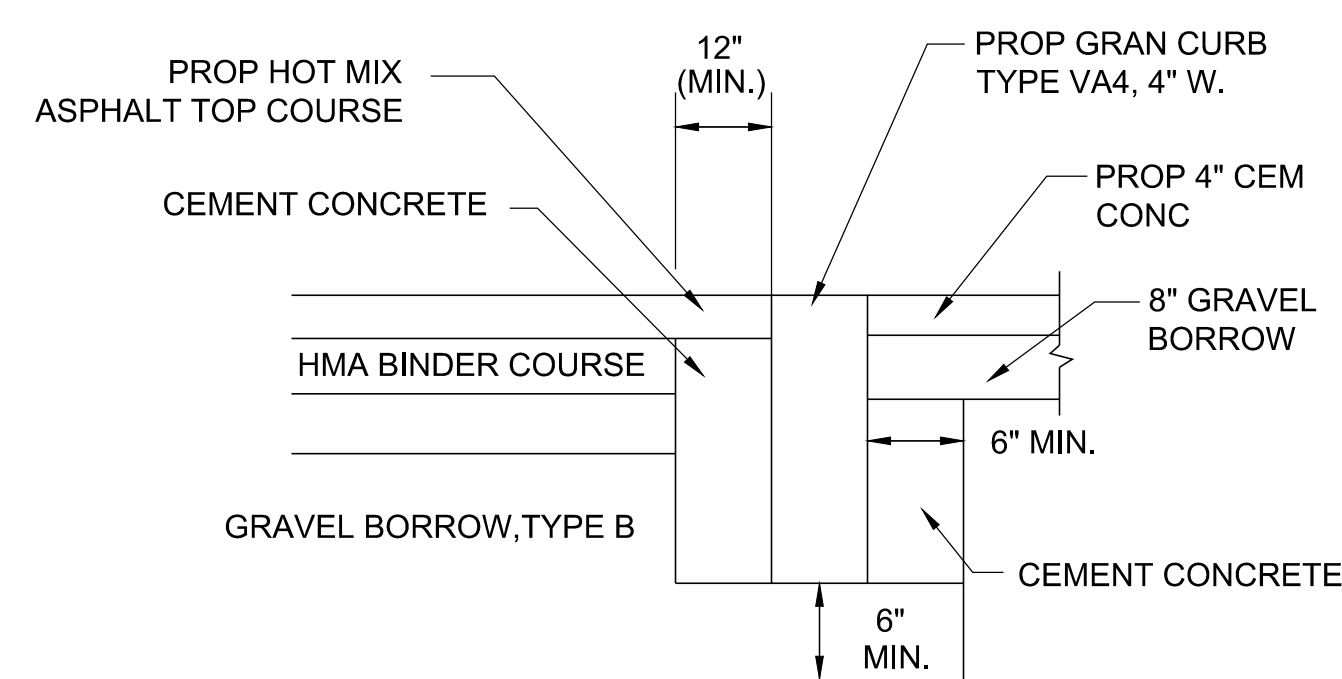

2 FLUSH GRANITE CURB INSTALLATION IN FULL DEPTH PAVEMENT
SCALE: N.T.S.

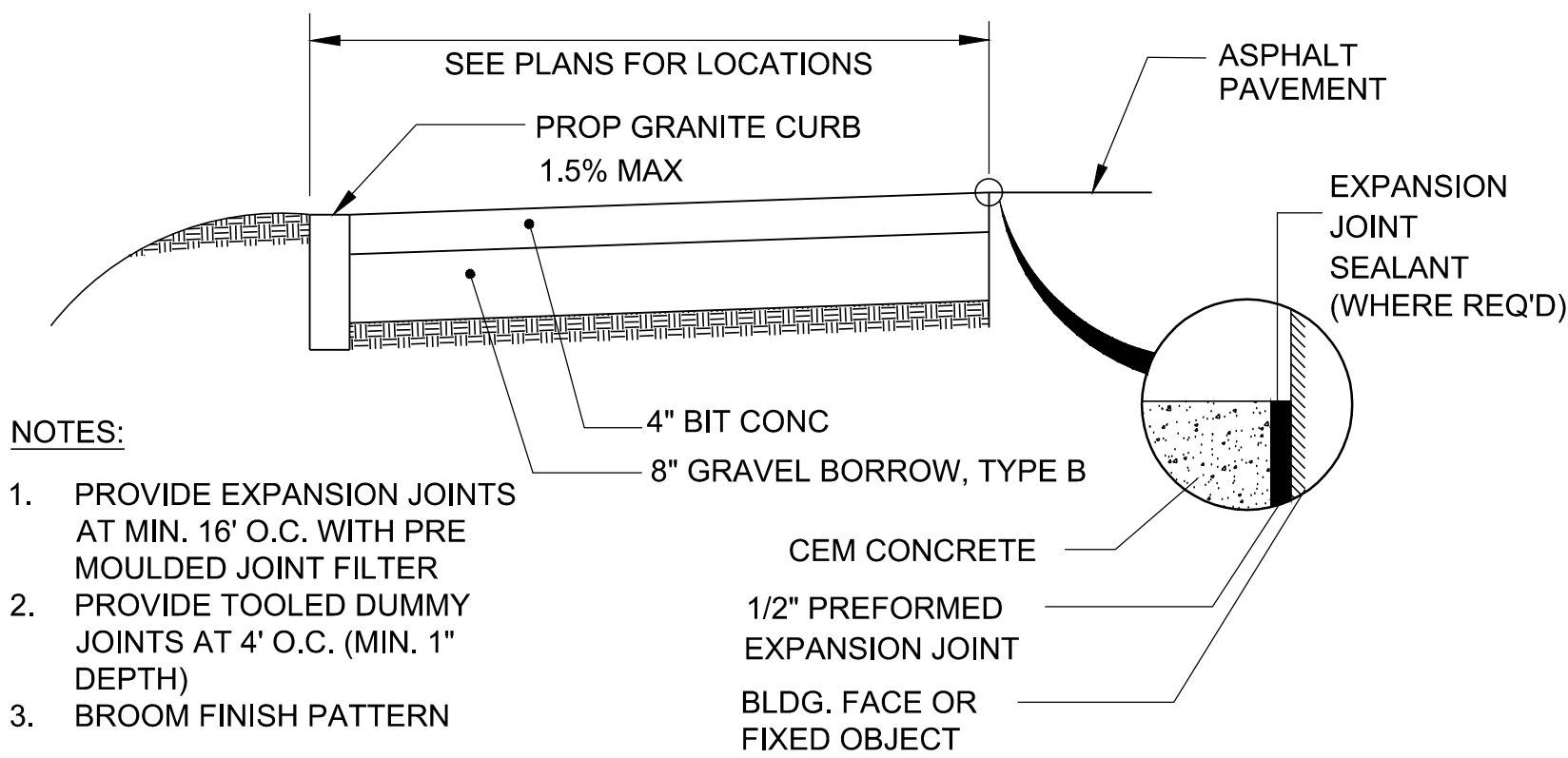

3 CEMENT CONCRETE WALK
SCALE: N.T.S.

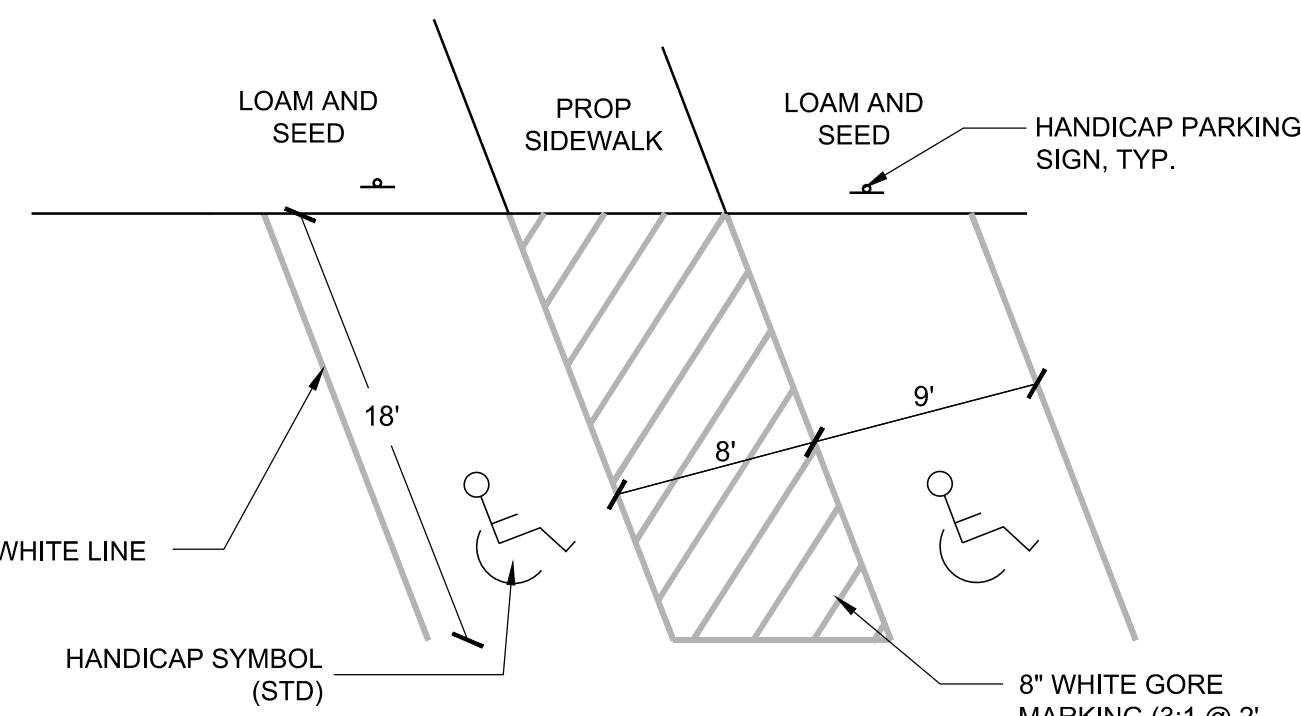

4 HANDICAP PARKING STALLS AND SYMBOLS
SCALE: N.T.S.

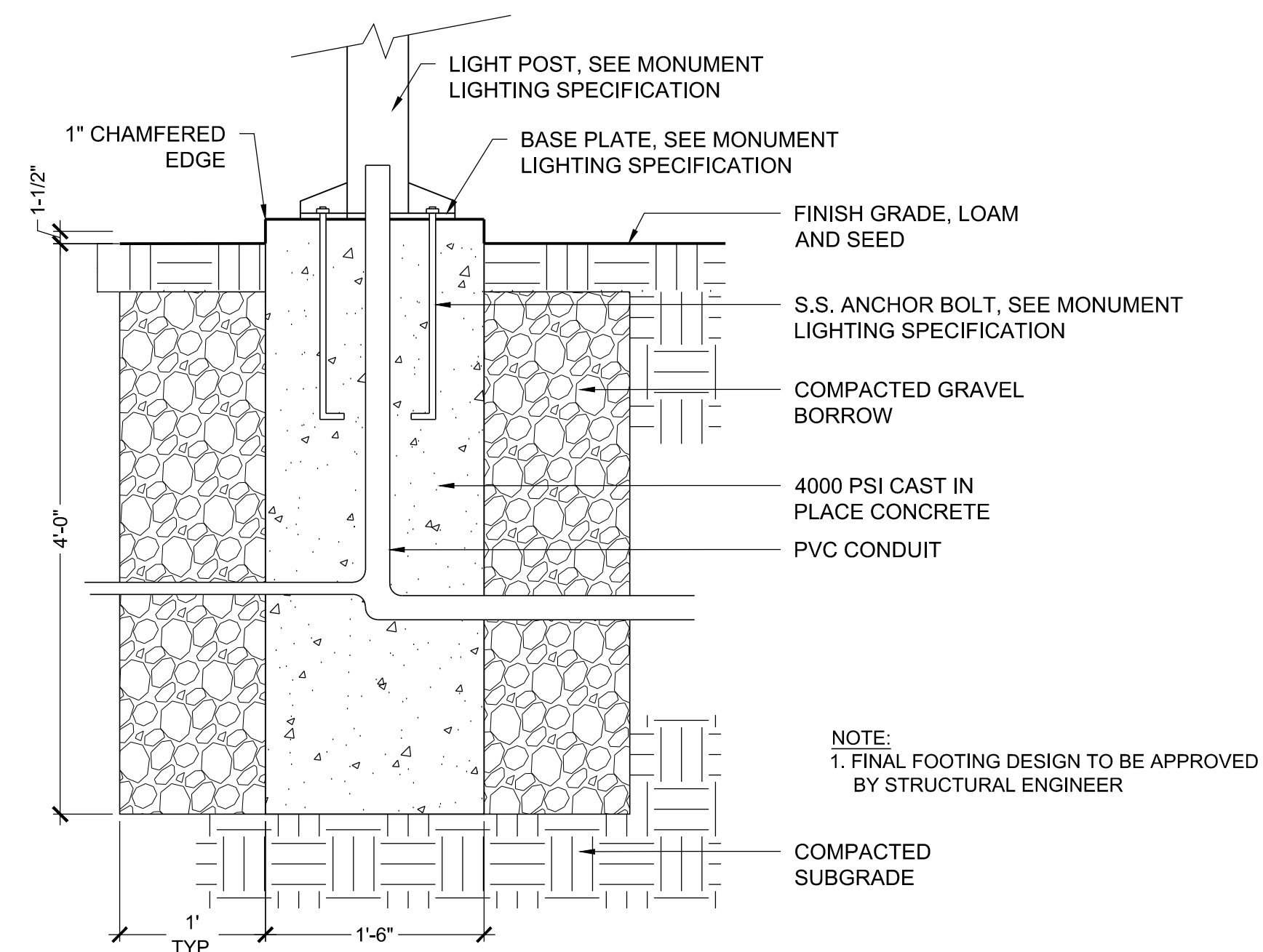

5 PEDESTRIAN LIGHT POST FOOTING
SCALE: N.T.S.

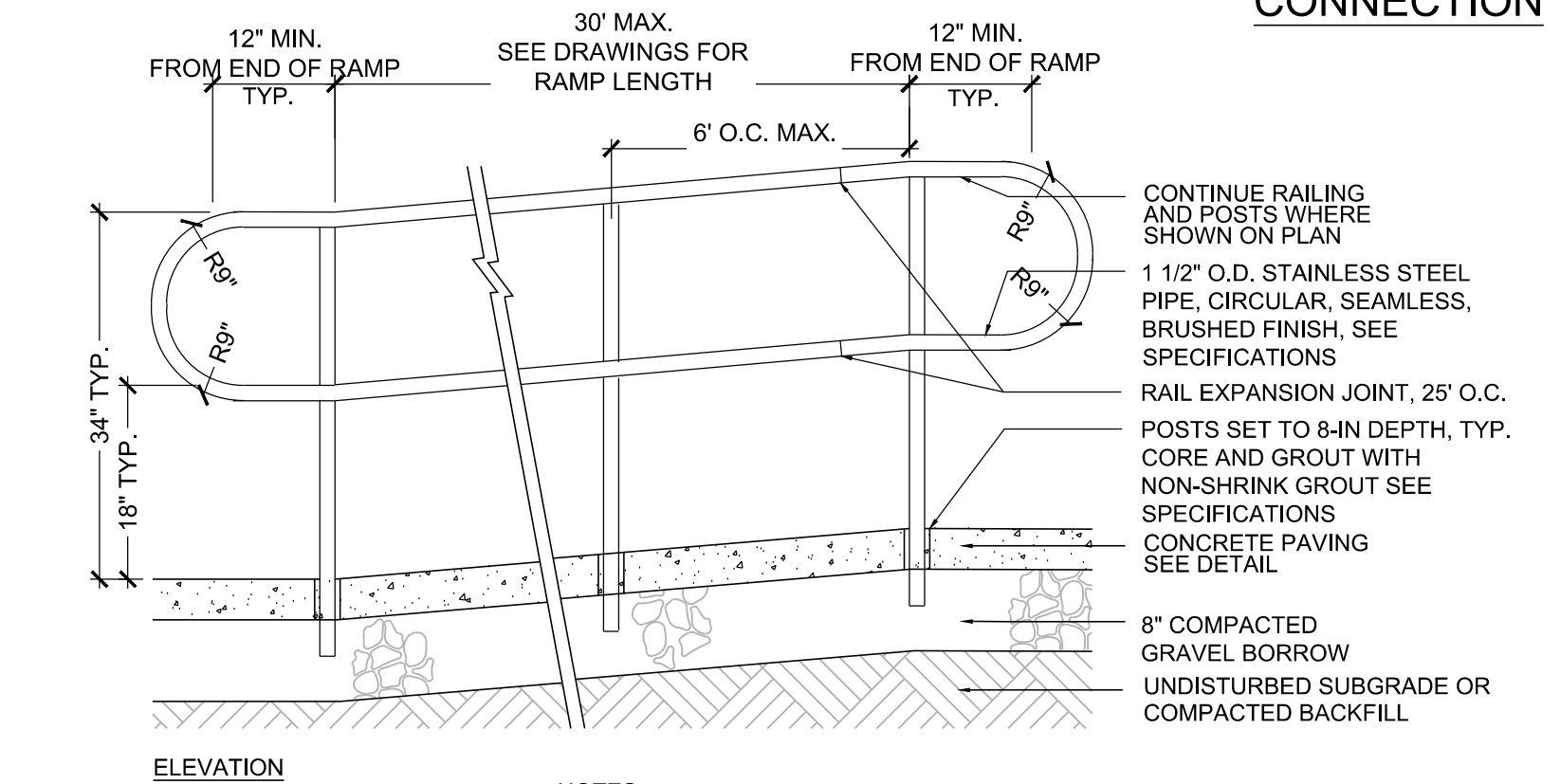
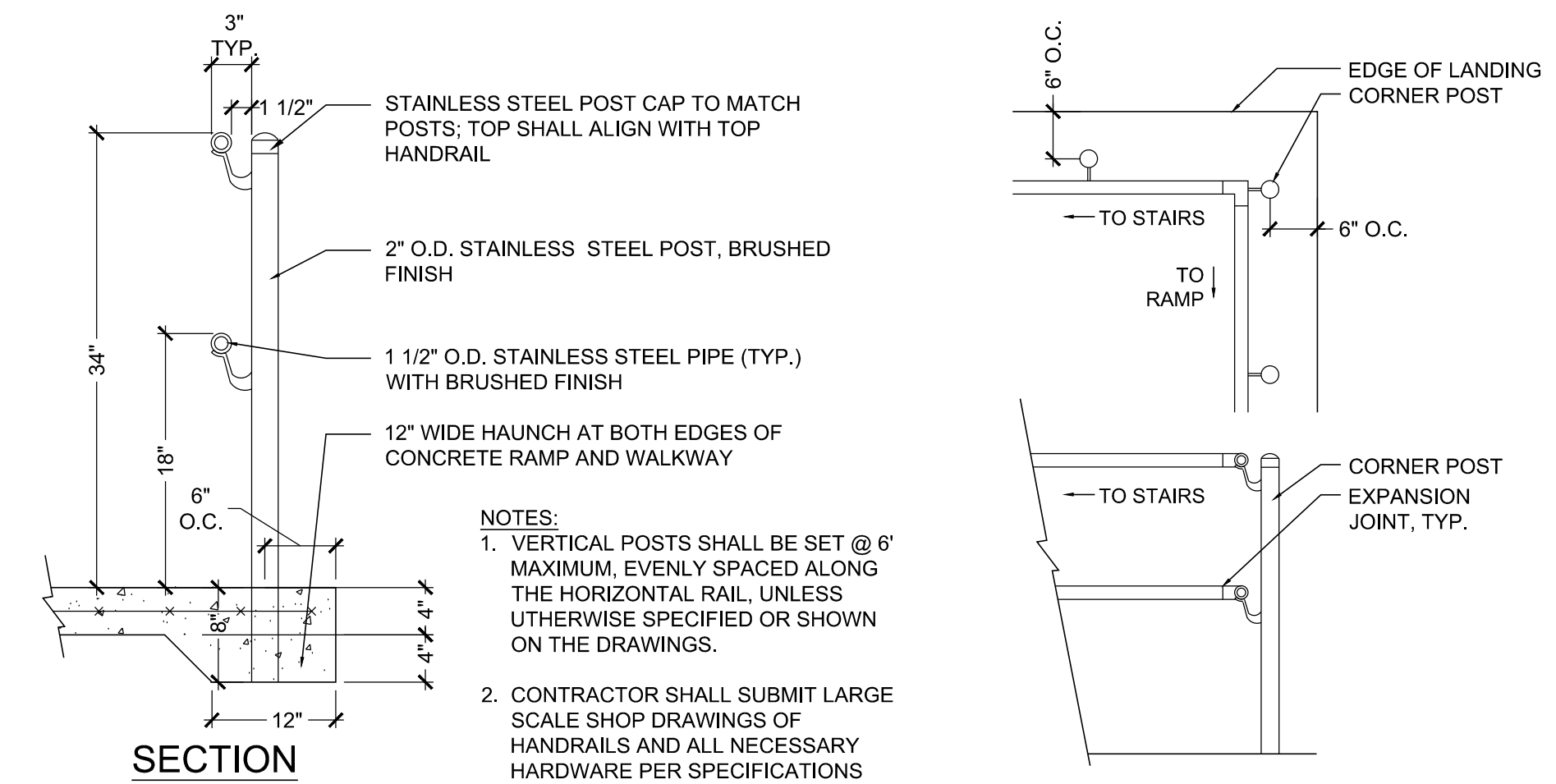

6 CAST-IN-PLACE CONCRETE RAMP WITH HANDRAIL
SCALE: N.T.S.

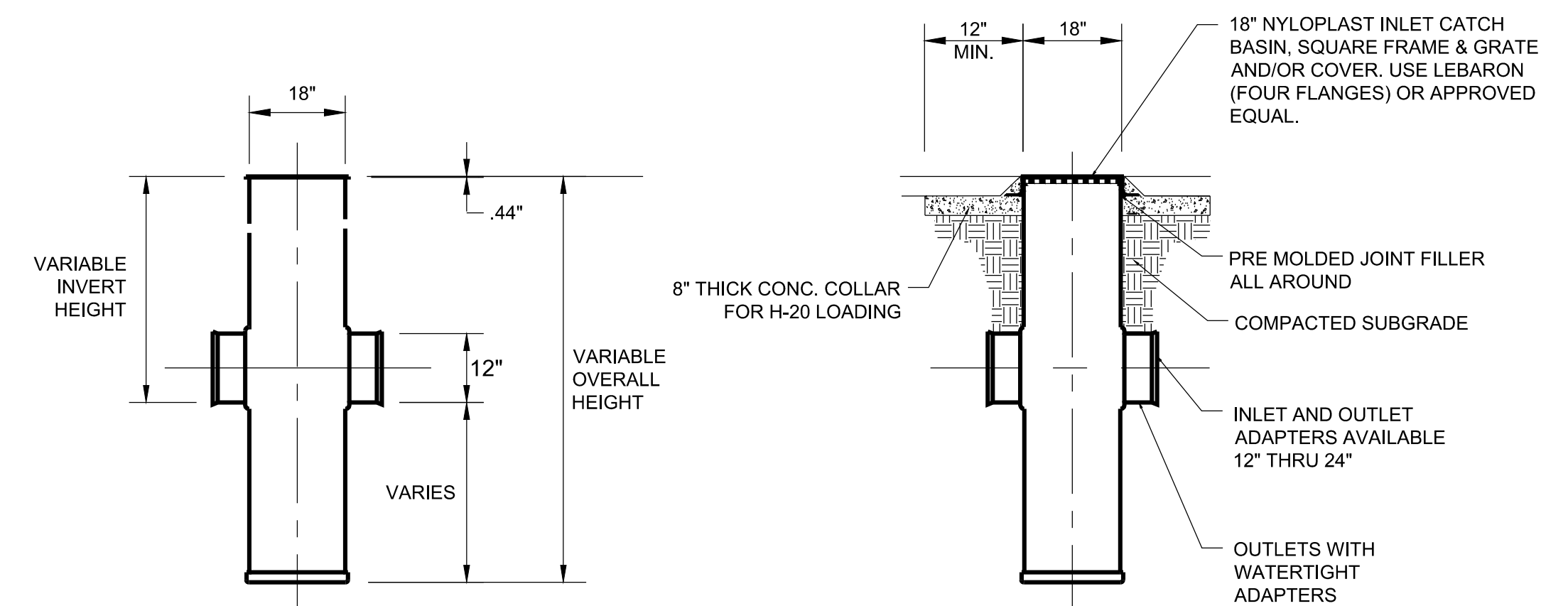

7 PVC MANHOLE / CATCH BASIN (DRAIN INLET)
SCALE: N.T.S.

Revisions:

Rev	Date	Description

Seal:

PLANS FOR CONSTRUCTION

Date:	09.18.2015
Scale:	AS SHOWN
Drawn By:	CCC/ EJA
Reviewed By:	BK
Checked By:	MSM
Approved By:	

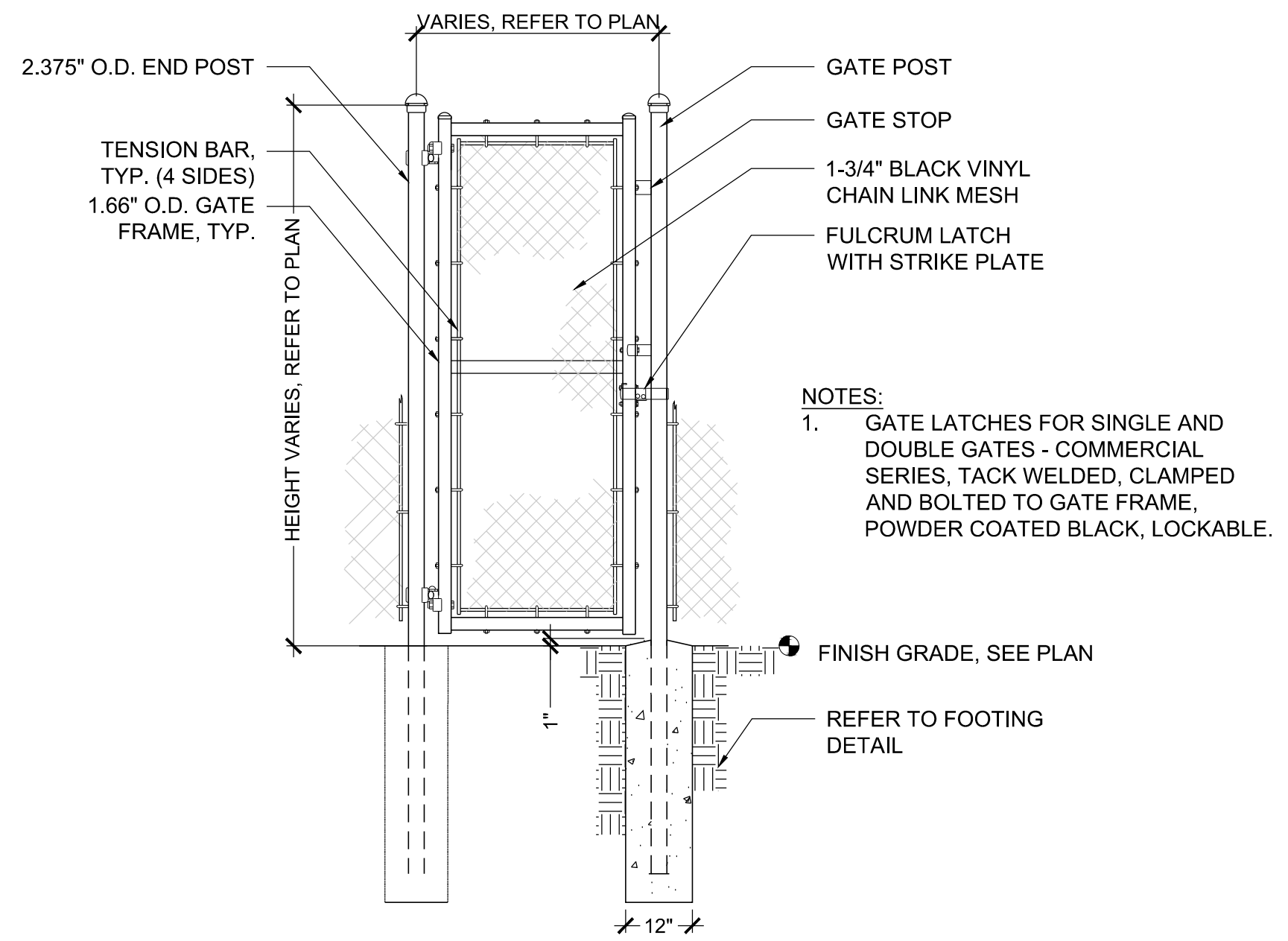

1 BLACK VINYL CHAIN LINK FENCE SINGLE GATE
SCALE: N.T.S.

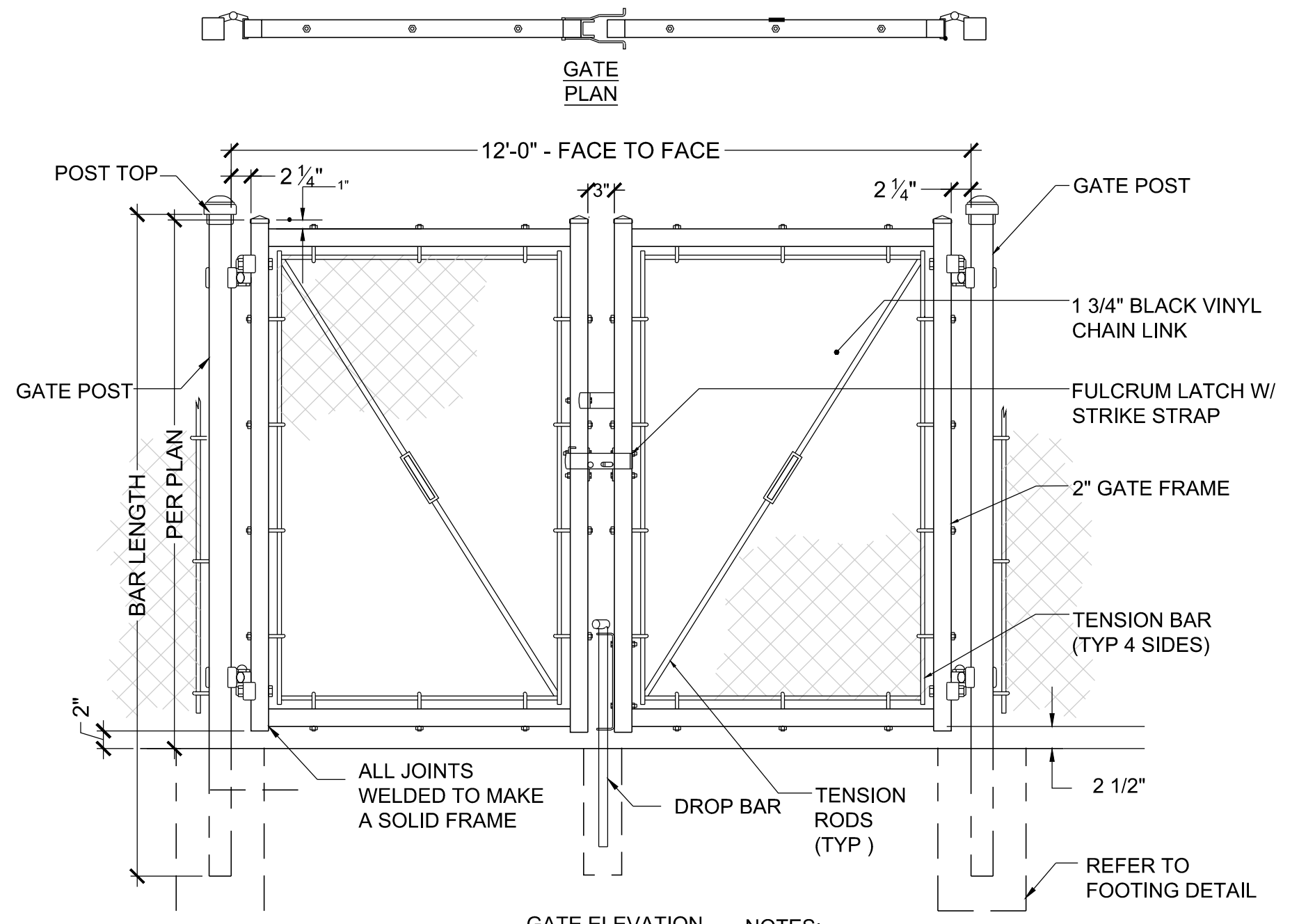

2 BLACK VINYL CHAIN LINK FENCE DOUBLE SWING GATE
SCALE: N.T.S.

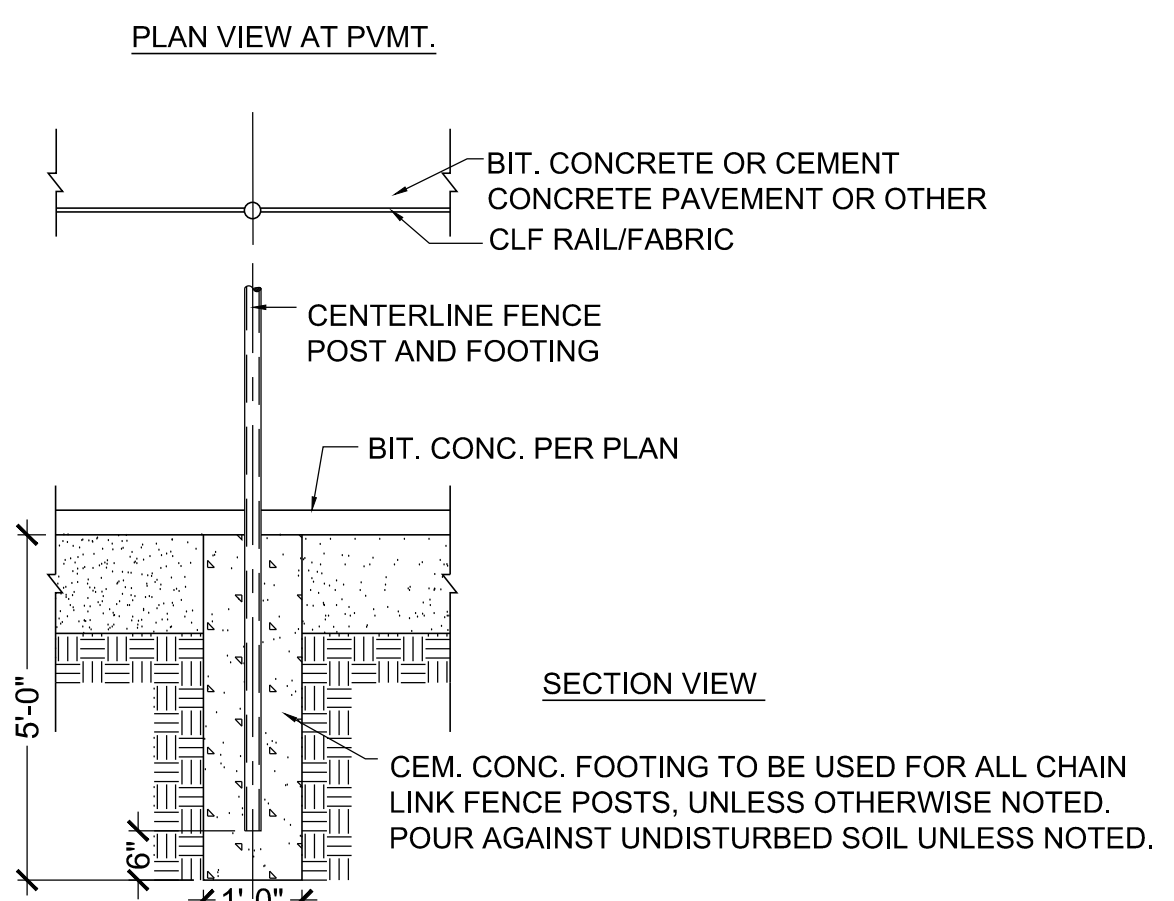

3 TYPICAL FENCE POST FOOTING
SCALE: N.T.S.

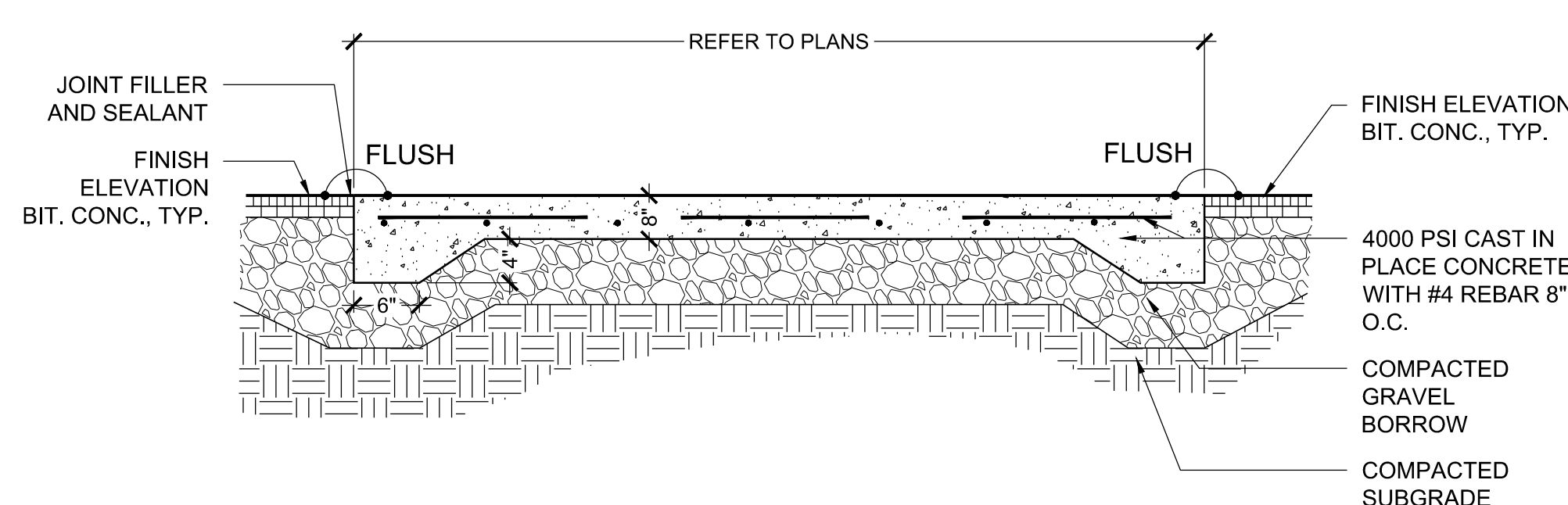

4 GATE STOP
SCALE: N.T.S.

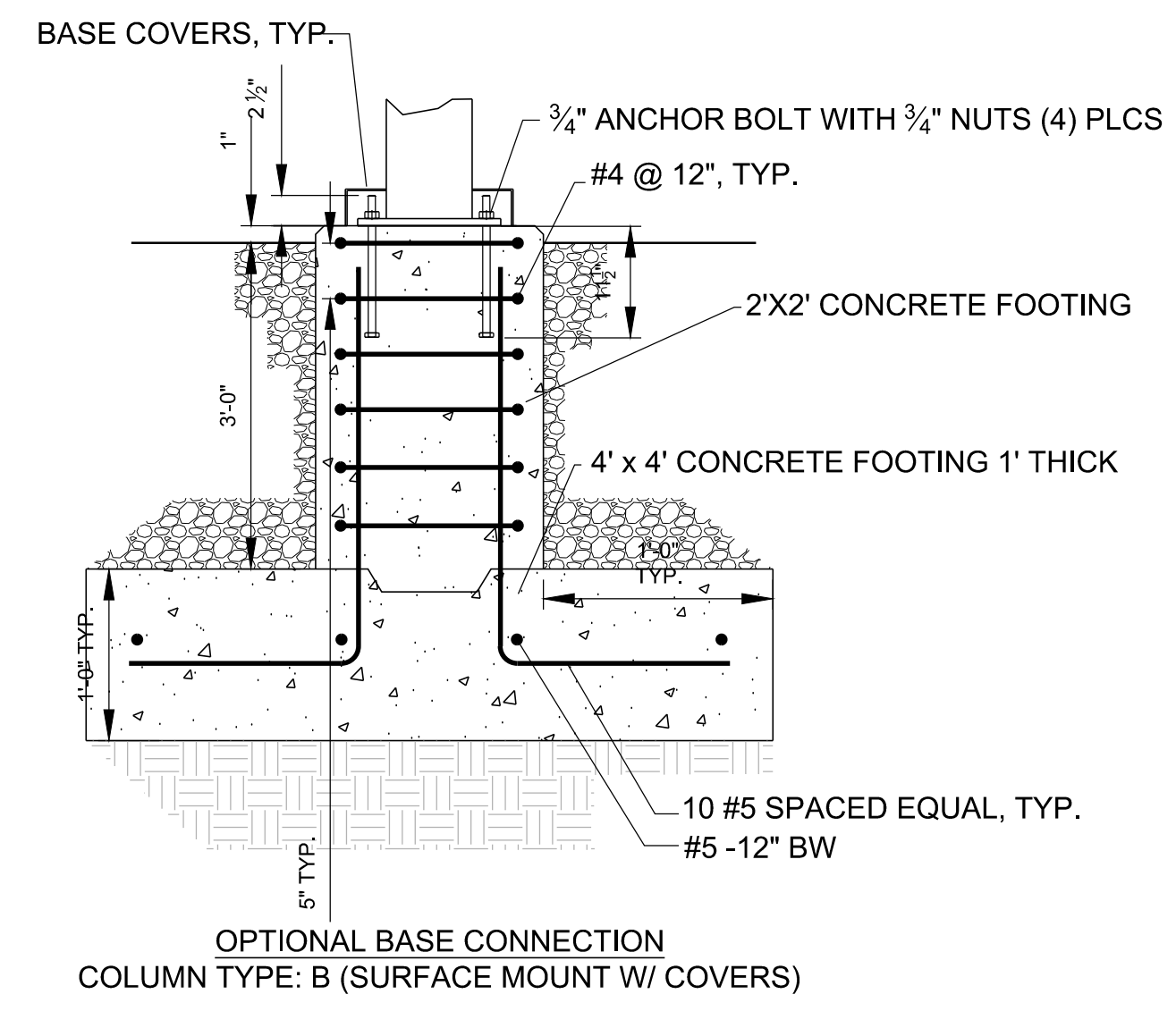

5 PRECAST CONCRETE SEGMENTAL BLOCK RETAINING WALL
SCALE: N.T.S.

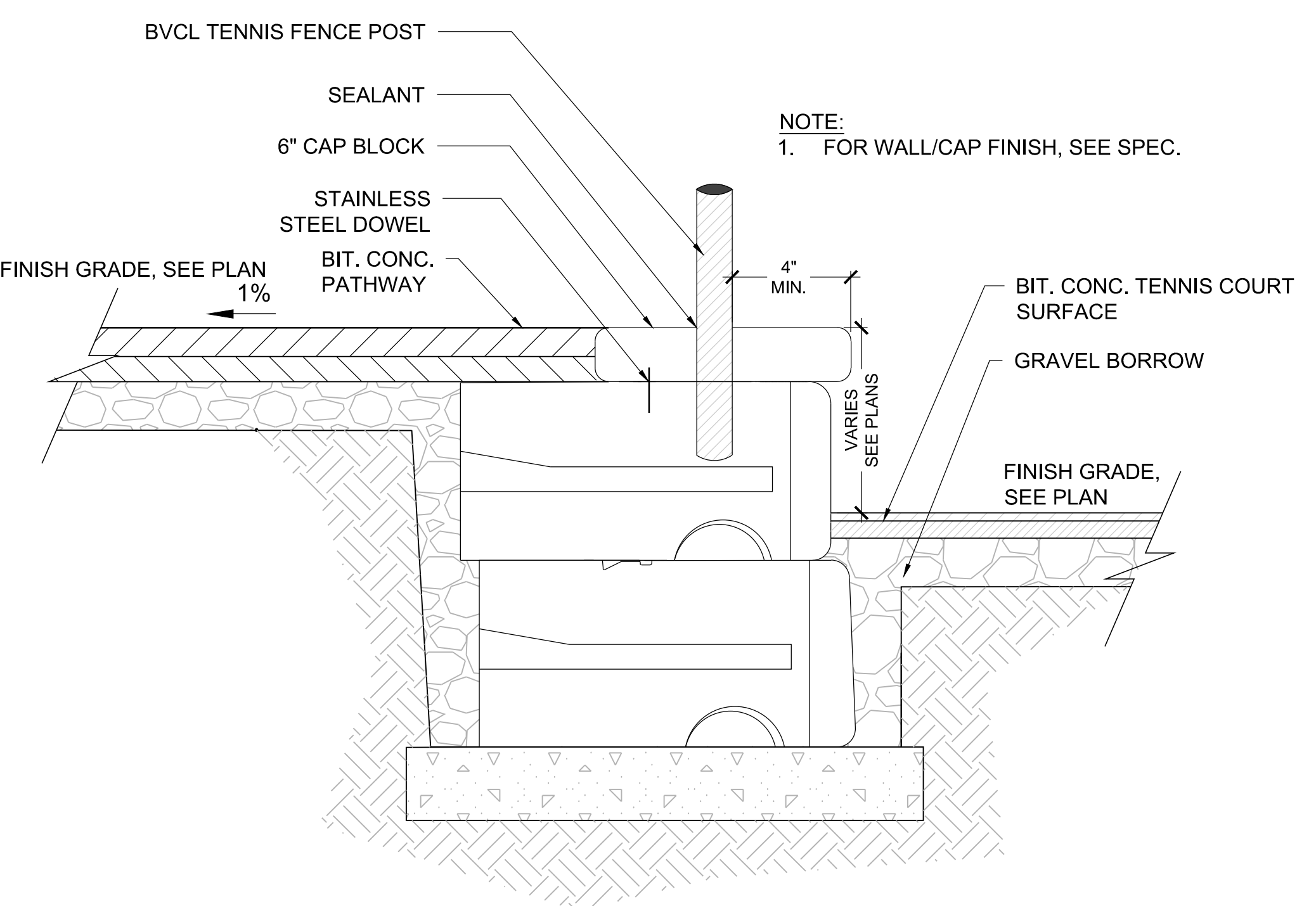

6 CAST IN PLACE CONCRETE PAD
SCALE: N.T.S.

6 SHADE SHELTER FOOTING
SCALE: N.T.S.

Revisions:

Rev	Date	Description

Seal:

PLANS FOR CONSTRUCTION

Date:	09.18.2015
Scale:	AS SHOWN
Drawn By:	EJAJ CCC
Reviewed By:	BK
Checked By:	MSM
Approved By:	

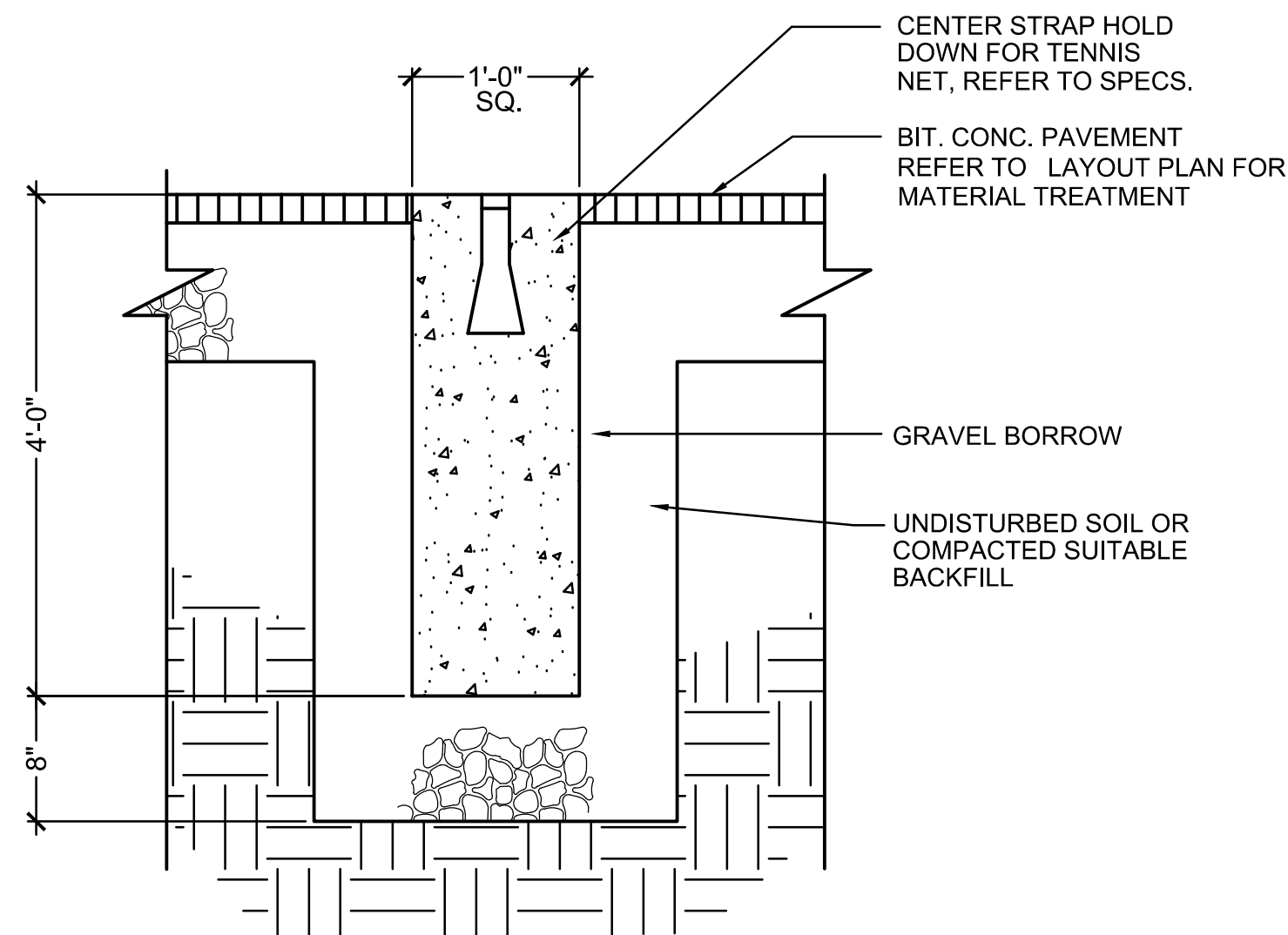

1 TENNIS NET TIE DOWN

SCALE: N.T.S.

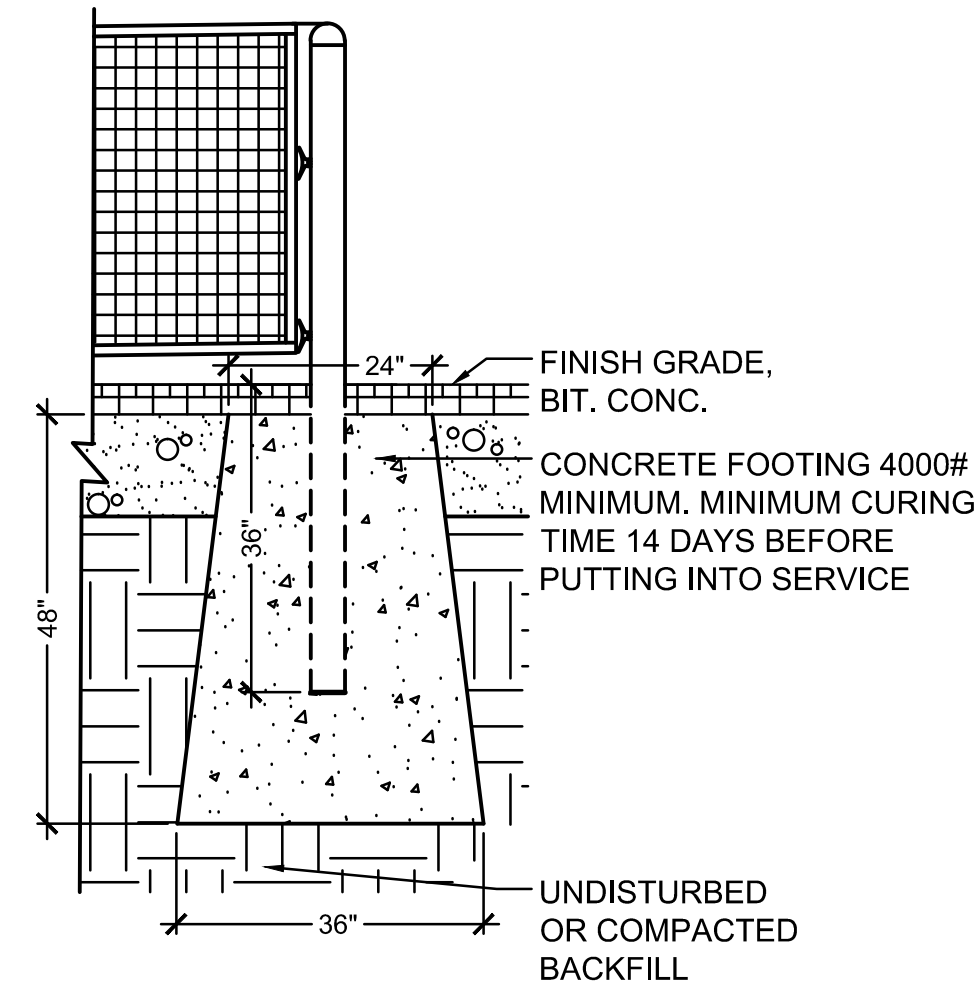

2 TENNIS POST FOOTING

SCALE: N.T.S.

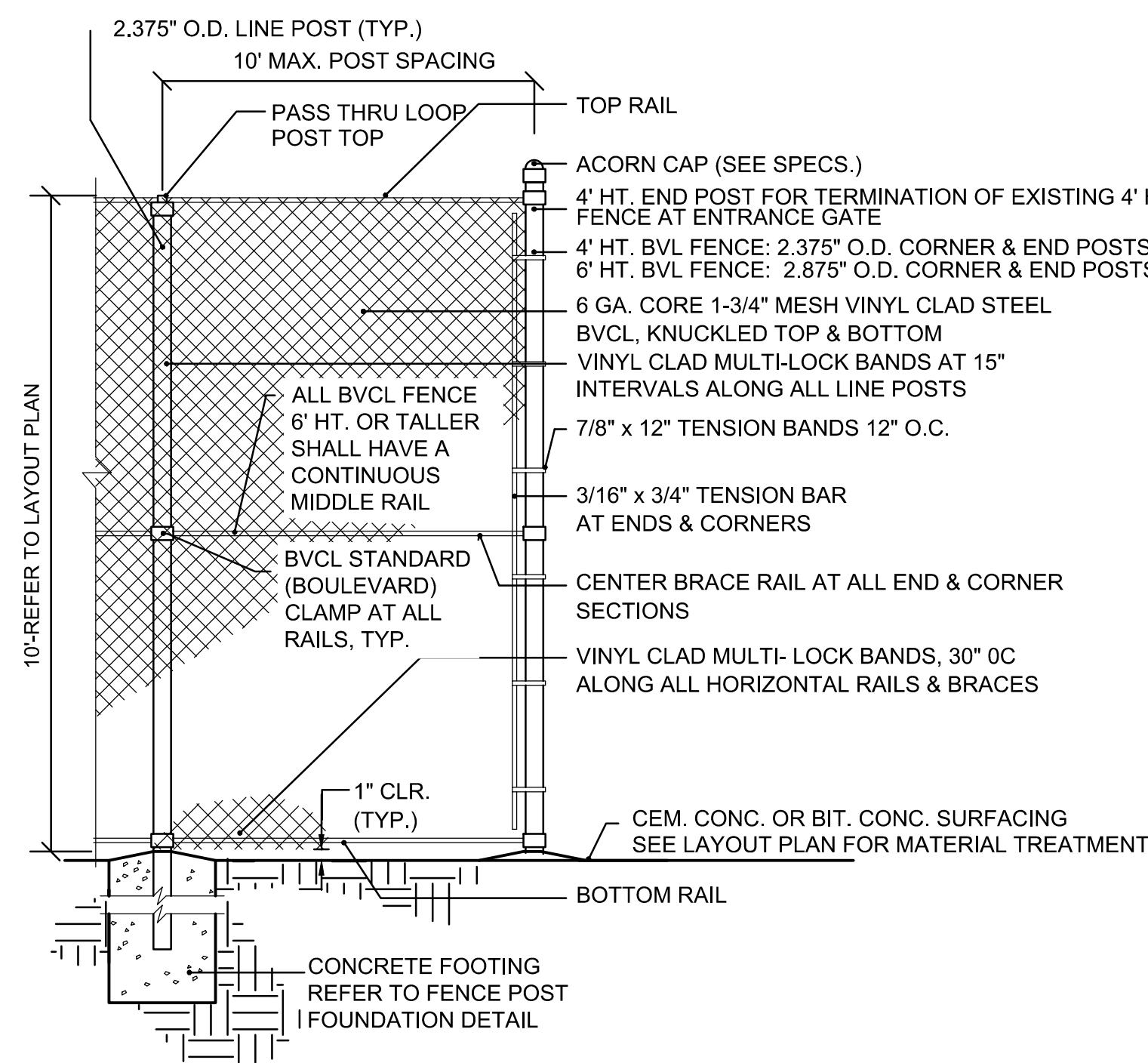

NOTES:

- 1 3/4" MESH VINYL-CLAD STEEL CHAIN LINK FABRIC, KNUCKLED TOP AND BOTTOM.
- 2 ALL FENCE PIPE SHALL BE SCH. 40, VINYL CLAD HOT DIP GALV. STEEL PIPE.
- 3 ALL LINE POSTS SHALL BE INSTALLED EQUALLY SPACED BETWEEN END & CORNER POSTS.
- 4 ALL RAILS SHALL BE 1.66" O.D. PIPE
- 5 ALL CLAMPS, TIES, POST TOPS, BANDS, POSTS, ETC. SHALL BE VINYL CLAD TO MATCH FABRIC.
- 6 REFER TO EL SERIES DRAWINGS FOR BONDING AND GROUNDING REQUIREMENTS
- 7 REFER TO SPECS. FOR GATE REQUIREMENTS.

3 TENNIS BLACK VINYL CHAIN LINK FENCE

SCALE: N.T.S.

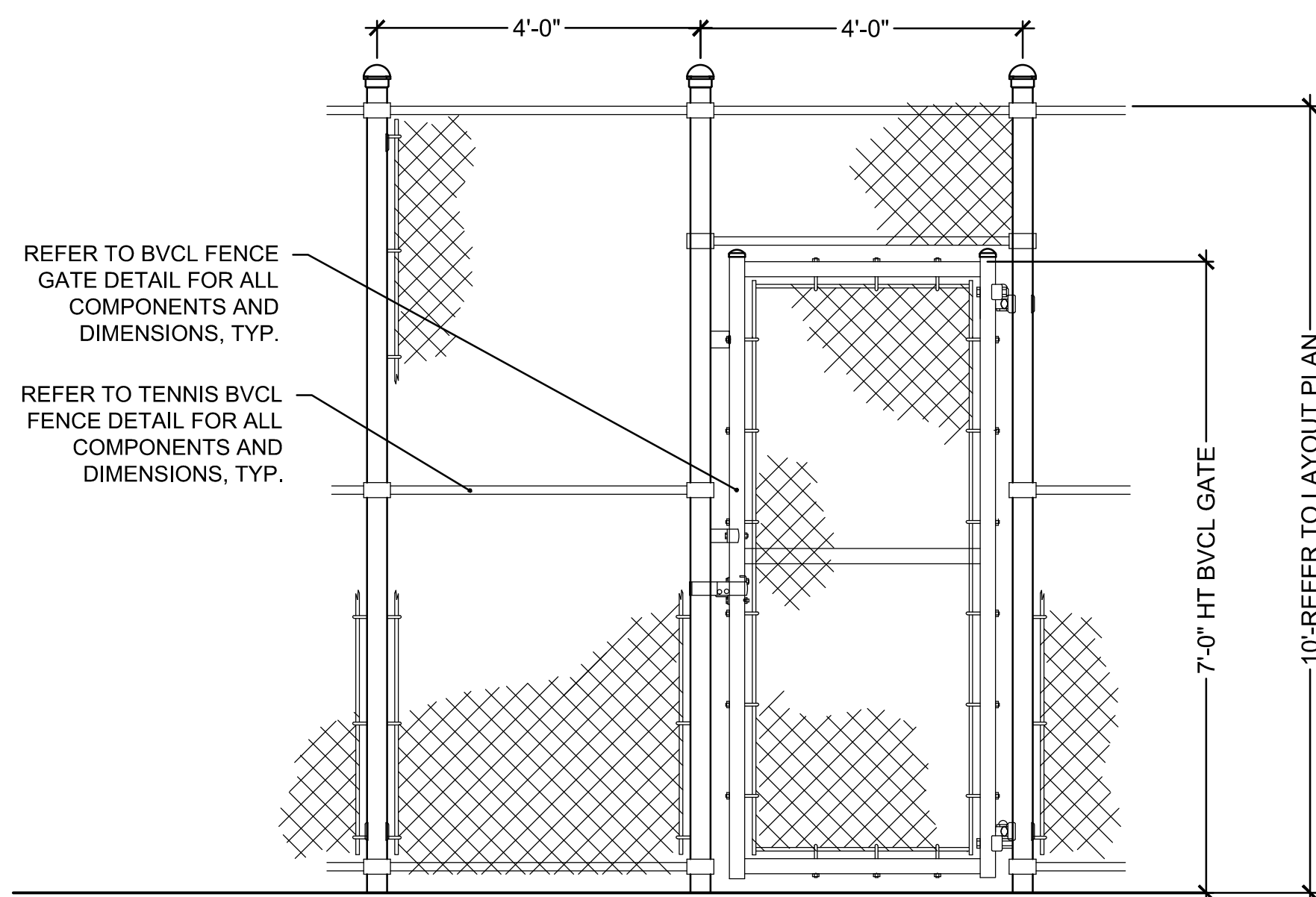

TENNIS GATE ELEVATION

- NOTES:**
1. ALL GATE PLANS AND ELEVATIONS FOR LAYOUT REFERENCE ONLY.

4 TENNIS GATES AT CUT CORNERS

SCALE: N.T.S.

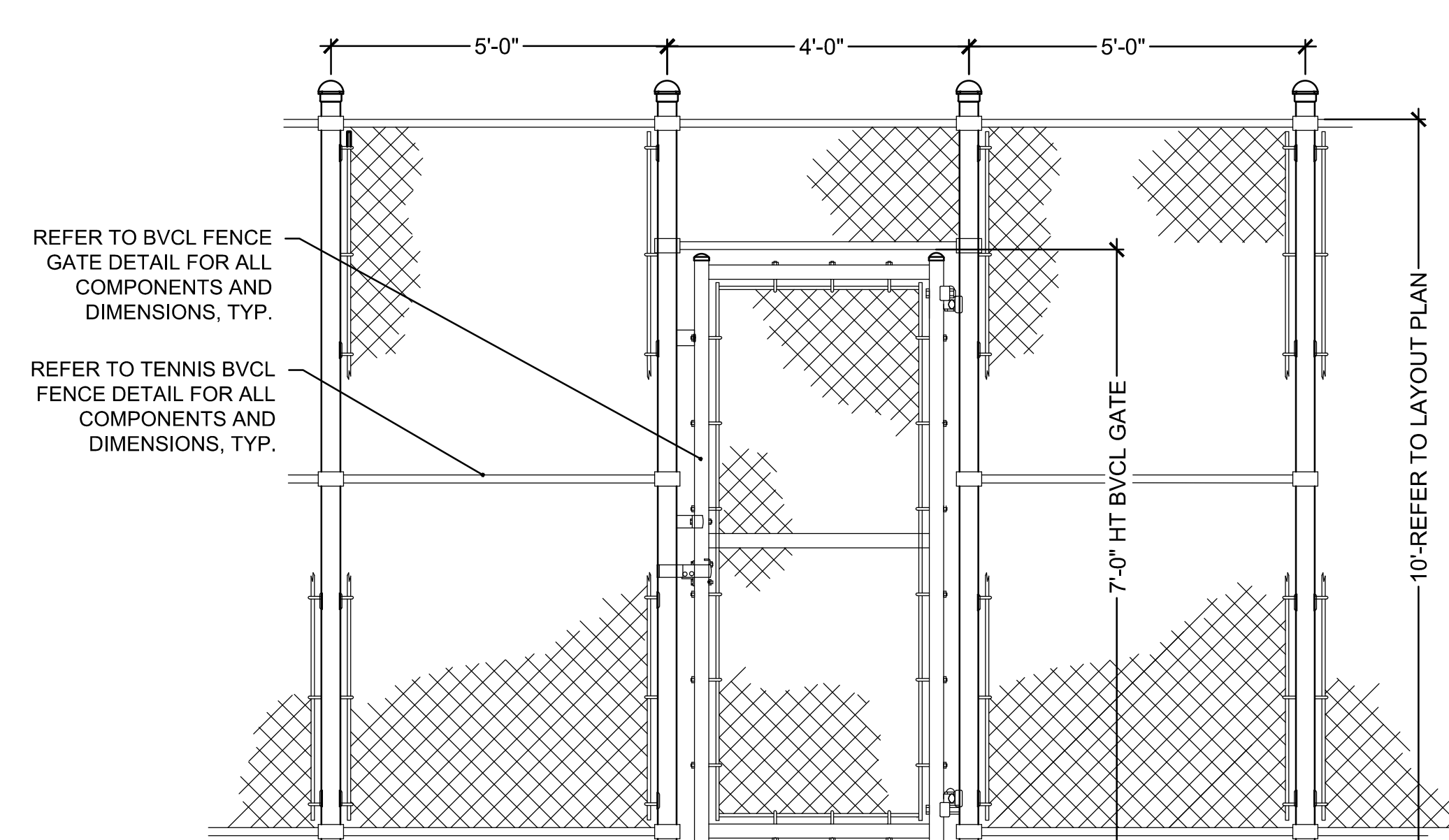

TENNIS GATE ELEVATION

- NOTES:**
1. ALL GATE PLANS AND ELEVATIONS FOR LAYOUT REFERENCE ONLY.

5 TENNIS GATES FOR WIDE CUT CORNERS

SCALE: N.T.S.

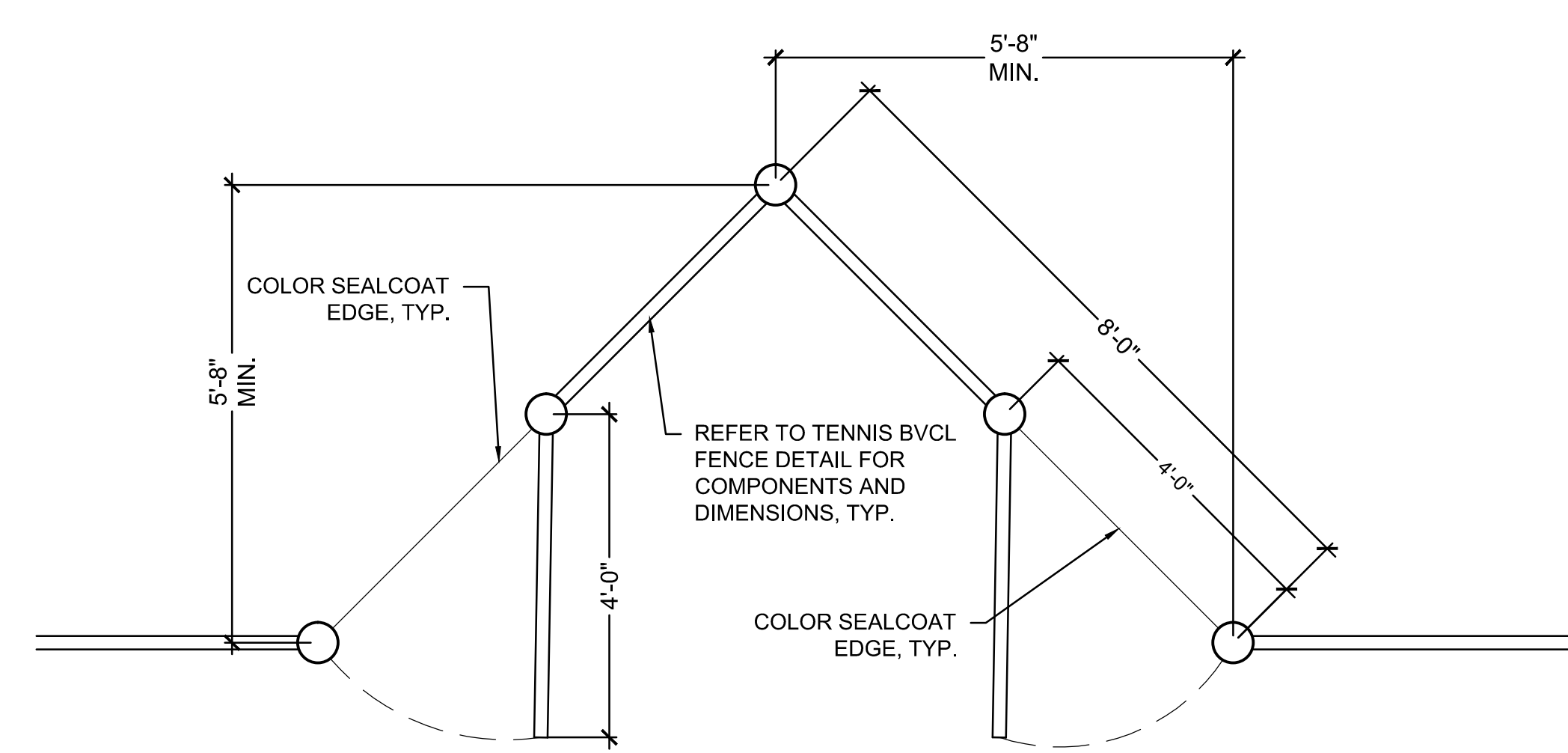

TENNIS GATE PLAN FOR TWO CUT CORNERS

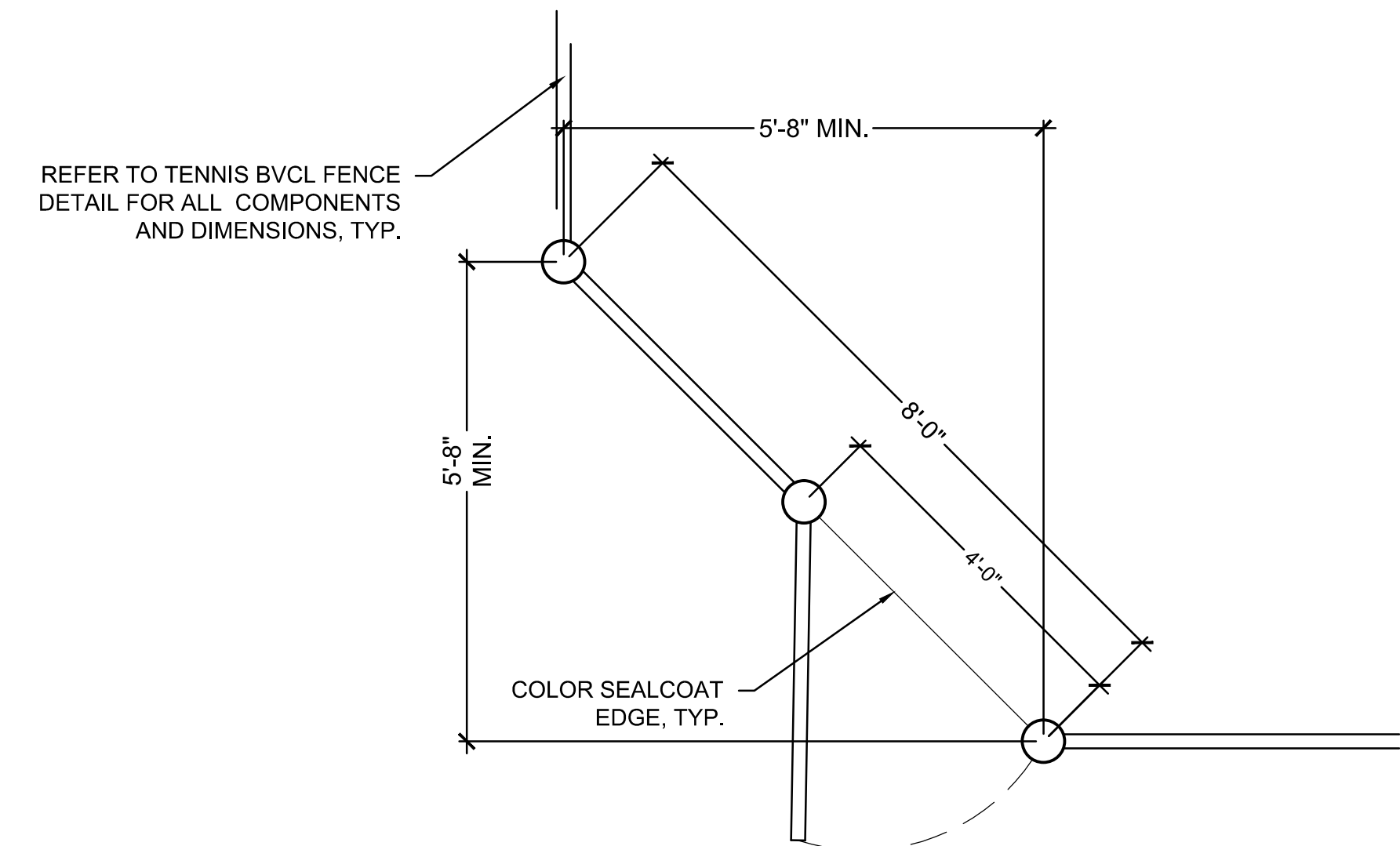

TENNIS GATE PLAN FOR ONE CUT CORNER

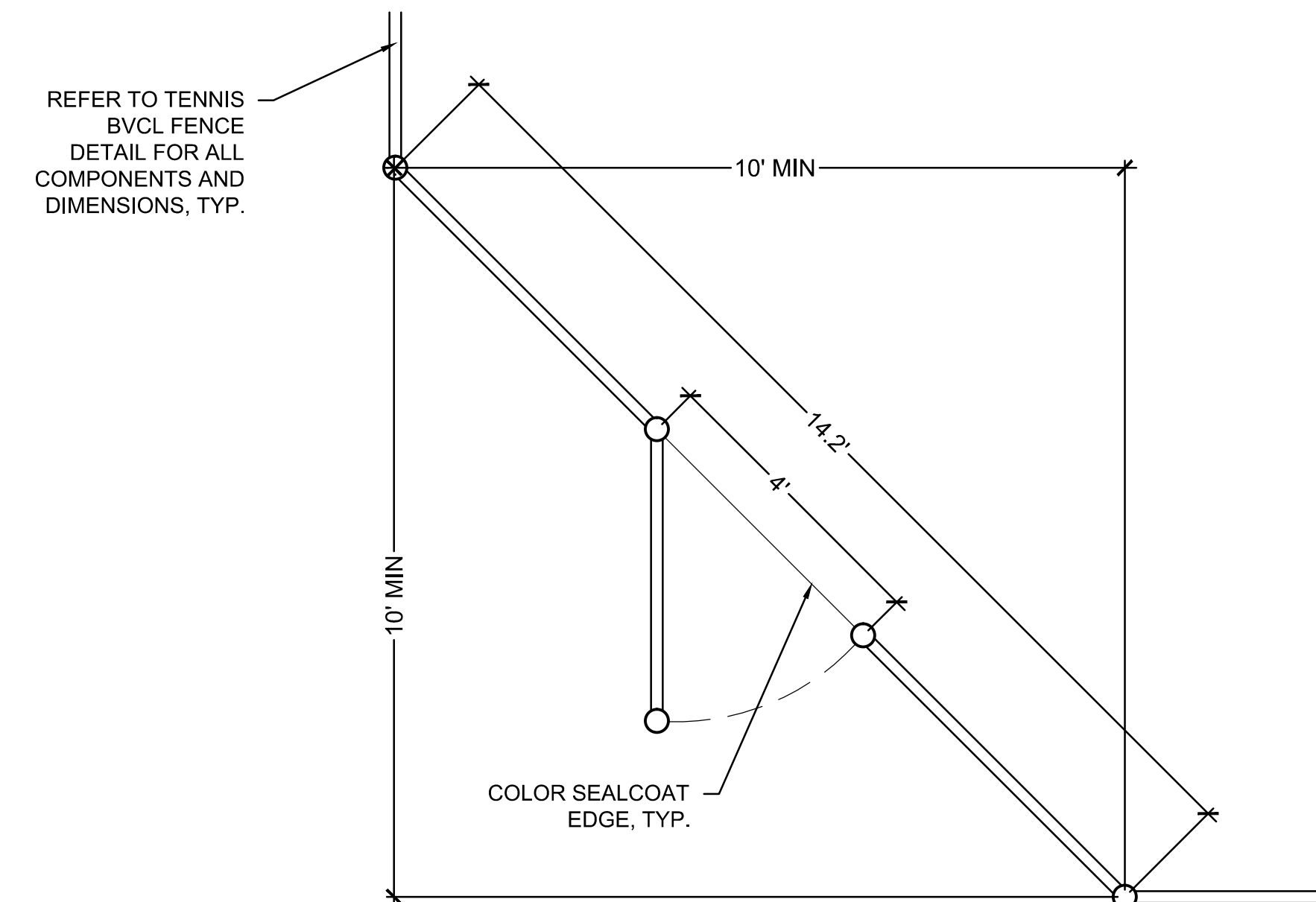

TENNIS GATE PLAN FOR ONE WIDE CUT CORNER

Consultants:

North:

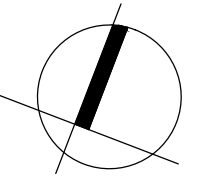

Revisions:

Rev	Date	Description

Seal:

PLANS FOR CONSTRUCTION

Date: 09.18.2015
Scale: AS SHOWN
Drawn By: EJA/CCC
Reviewed By: BK
Checked By: MSM
Approved By:

Drawing Title:
CONSTRUCTION DETAILS

Sheet Number:
L5.04

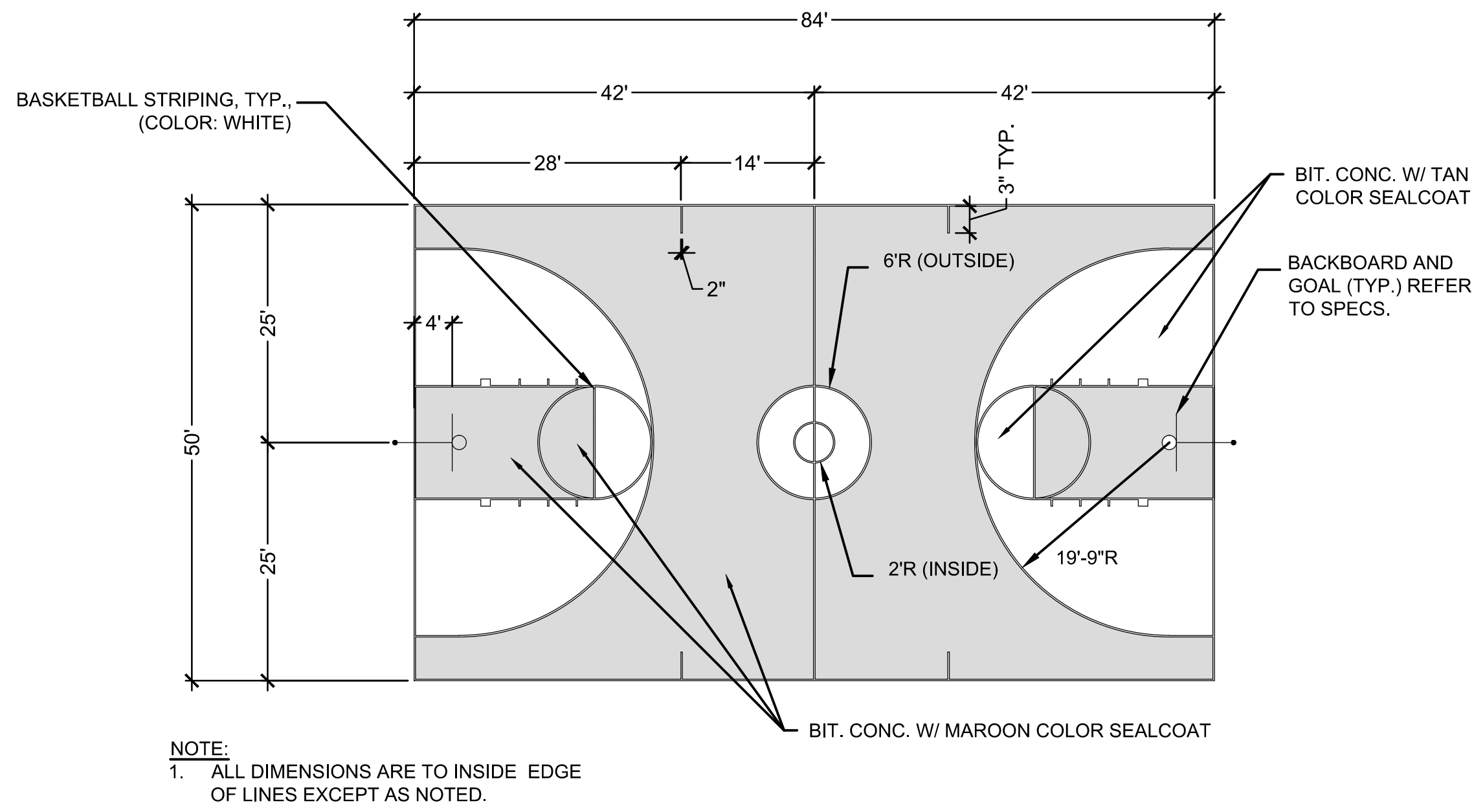

1 BASKETBALL COURT STRIPING AND COLOR SEALCOAT
SCALE: N.T.S.

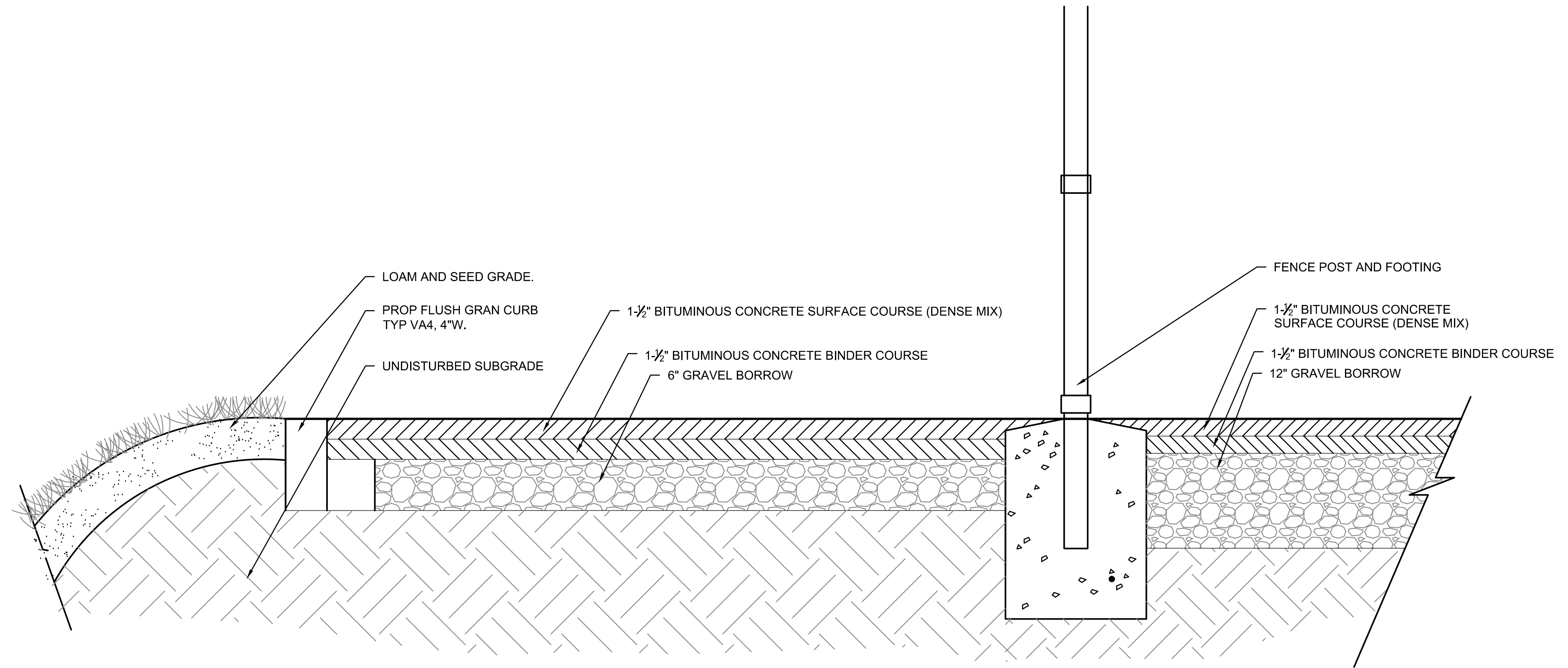

B SECTION A-A' - PEDESTRIAN PATHWAY WITH FLUSH GRANITE CURB
SCALE: N.T.S.

NOTE:
1. ALL STREET HOCKEY COURT STRIPING SHALL BE PAINTED USING A COLOR DIFFERENT & CONTRASTING TO THE TENNIS COURT STRIPING.

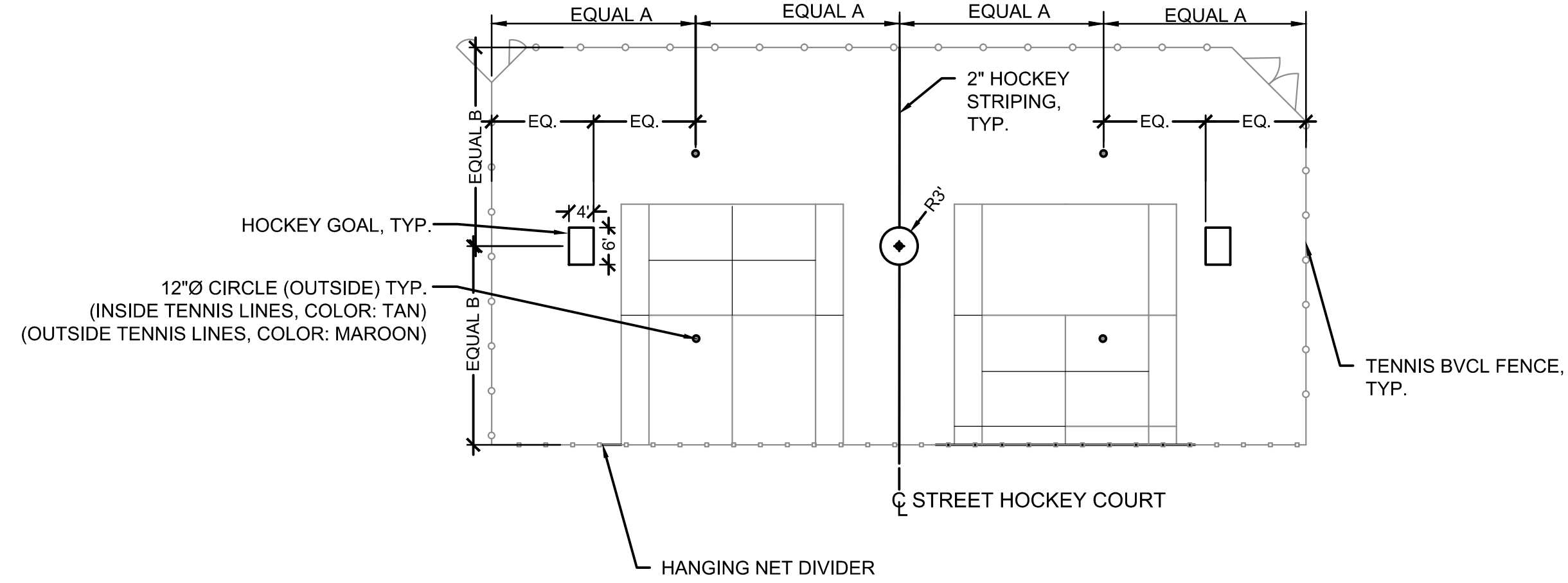

2 STREET HOCKEY COURT STRIPING OVERLAY AT TENNIS COURTS
SCALE: N.T.S.

NOTES:
1. ALL DIMENSIONS ARE TO THE OUTSIDE EDGE OF LINES.
2. CENTER SERVICE LINE AND CENTER MARK SHALL BE 2 INCHES WIDE. OTHER LINES SHALL BE BETWEEN 1" AND 2" WIDE, EXCEPT THE BASELINES MAY BE UP TO
3. QUICK START STRIPING SHALL ALTERNATE ON ADJACENT TENNIS COURT

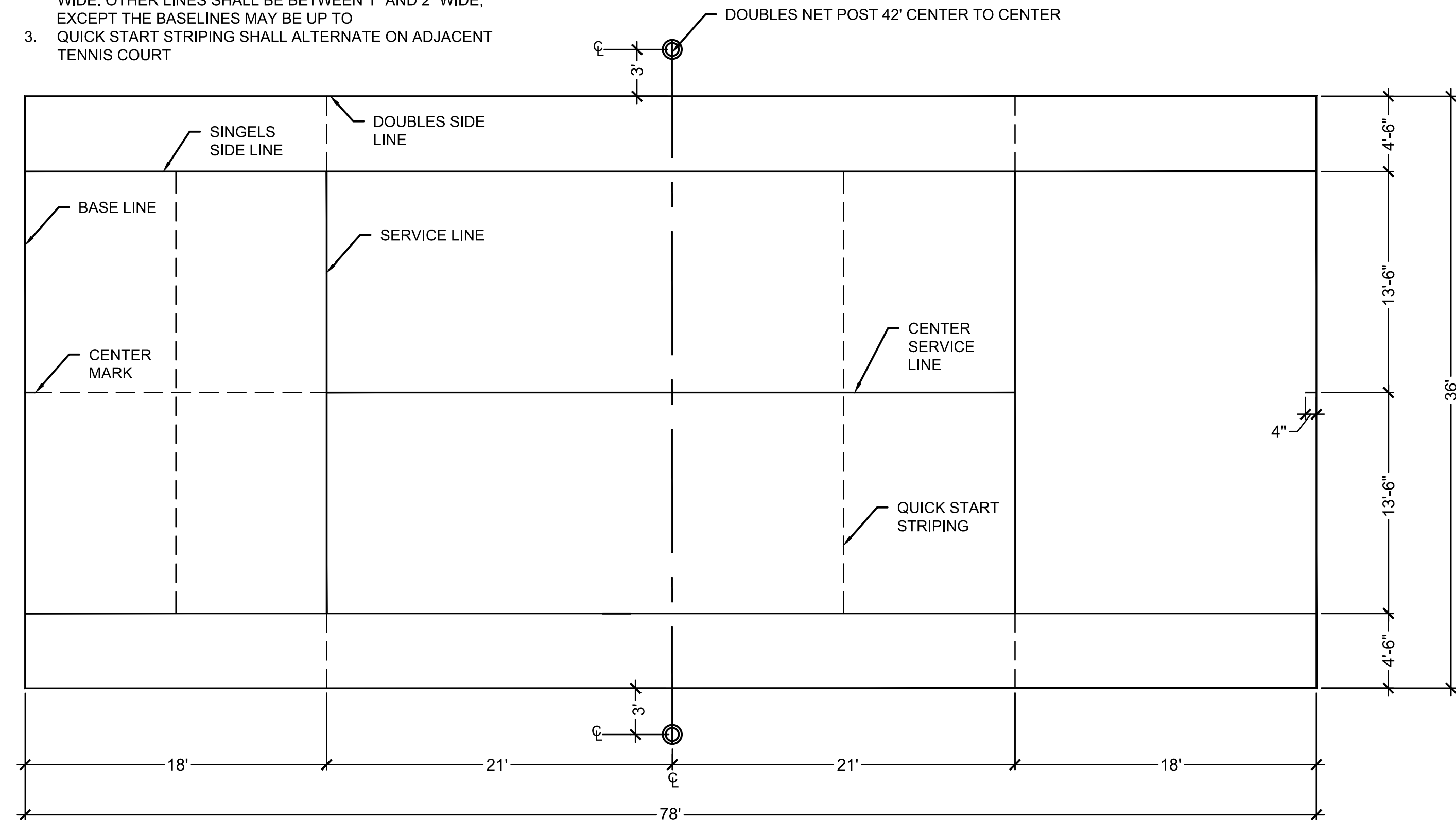

3 TENNIS COURT STRIPING
SCALE: N.T.S.

Consultants:

North:

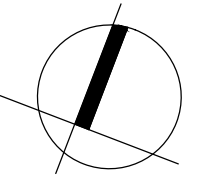

Revisions:

Rev	Date	Description

Seal:

**PLANS FOR
CONSTRUCTION**

Date: 09.18.2015
Scale: AS SHOWN
Drawn By: EJA/CCC
Reviewed By: BK
Checked By: MSM
Approved By:

Drawing Title:
**CONSTRUCTION
DETAILS**

Sheet Number:
L5.05

GENERAL ELECTRICAL NOTES :

- DRAWINGS ARE DIAGRAMMATIC ONLY. THE EXACT LOCATION, MOUNTING HEIGHTS, SIZE OF EQUIPMENT AND ROUTING OF RACEWAYS SHALL BE COORDINATED AND DETERMINED IN THE FIELD.
- WORK SHALL CONFORM TO THE MASSACHUSETTS ELECTRICAL CODE AND MASSACHUSETTS BUILDING CODE AND REQUIREMENTS OF LOCAL AUTHORITIES HAVING JURISDICTION.
- THE WORD "CONTRACTOR" AS USED IN THE "ELECTRICAL WORK" SHALL MEAN THE ELECTRICAL SUBCONTRACTOR.
- CONTRACTOR SHALL PAY FOR ALL PERMITS, INSURANCE AND TESTS, AND SHALL PROVIDE LABOR AND MATERIAL TO COMPLETE THE ELECTRICAL WORK SHOWN.
- CONTRACTOR SHALL PAY ELECTRIC UTILITY COMPANY BACKCHARGES AND PROVIDE COORDINATION WITH SAME.
- EXCEPT AS OTHERWISE NOTED, THE ELECTRICAL WORK SHALL INCLUDE PANELBOARDS, CIRCUIT BREAKERS, FEEDERS, WIRING, RACEWAYS, LIGHTING FIXTURES, DEVICES, SAFETY SWITCHES, MOUNTING AND WIRING, TRANSFORMERS AND CONNECTIONS NECESSARY TO OPERATE ALL EQUIPMENT.
- THE CONTRACTOR SHALL PROVIDE ALL TEMPORARY LIGHTING AND POWER AND PAY ALL ENERGY CHARGES.
- DURING CONSTRUCTION, THE ELECTRICAL CONTRACTOR SHALL KEEP HIS PORTION OF THE WORK NEAT, CLEAN AND ORDERLY.
- ALL SYSTEMS SHALL BE TESTED FOR SHORT CIRCUIT AND GROUNDS PRIOR TO ENERGIZING AND ANY DEFECTS SHALL BE CORRECTED.
- ALL CUTTING AND PATCHING REQUIRED FOR ELECTRICAL WORK SHALL BE INCLUDED AS PART OF THIS SECTION.
- COMPLETE SHOP DRAWINGS SHALL BE SUBMITTED FOR ELECTRICAL EQUIPMENT. WHERE SPECIFIED, ELECTRICAL EQUIPMENT IS SUBSTITUTED. THE ELECTRICAL CONTRACTOR SHALL SUBMIT COMPLETE SPECIFICATIONS ON THE SUBSTITUTE AS WELL AS THE ITEM ORIGINALLY SPECIFIED.
- MATERIALS SHALL BE SPECIFICATION GRADE AND UL LISTED.
- WHERE MATERIAL IS CALLED OUT IN THE LEGEND BY MANUFACTURER, TYPE OR CATALOG NUMBER, SUCH DESIGNATIONS ARE TO ESTABLISH STANDARDS OR DESIRED QUALITY. ACCEPTANCE OR REJECTIONS OF PROPOSED SUBSTITUTIONS SHALL BE SUBJECT TO THE APPROVAL OF THE OWNER.
- WORK SHALL BE COORDINATED WITH THAT OF OTHER TRADES TO ELIMINATE INTERFERENCES.
- ELECTRICAL WORK SHALL BE GUARANTEED FOR A PERIOD OF ONE YEAR FROM DATE OF WHICH SYSTEM IS PUT INTO SERVICE UNLESS OTHERWISE SPECIFIED.
- WORK SHALL BE GROUNDED IN ACCORDANCE WITH CODE REQUIREMENTS. COMPLETE EQUIPMENT (INSULATED GREEN WIRE) GROUNDING SYSTEM SHALL BE INSTALLED.
- WIRE SHALL BE TYPE "XLP" INSULATED FOR 600 VOLTS, MINIMUM SIZE #12 AWG COPPER UNLESS SPECIFICALLY NOTED OTHERWISE.
- WIRING METHODS:
 - BELOW GRADE WIRING SHALL BE SCHEDULE 80 PVC.
- PANELBOARDS SHALL BE DEAD FRONT, THERMAL MAGNETIC BOLT-ON CIRCUIT BREAKER TYPE, DESIGNED FOR SURFACE MOUNTING AS INDICATED ON PLAN, AND HAVING CONNECTIONS TO 480/277 VOLT, 3-PHASE, 4-WIRE AND 120/208 VOLT, 3-PHASE, 4-WIRE SERVICE. ALL BUS BARS SHALL BE COPPER. CABINETS SHALL BE MADE OF CODE GAUGE GALVANIZED SHEET STEEL, WITH A MINIMUM OF 4 INCH GUTTERS, DOOR IN DOOR CONSTRUCTION, LOCKED DOOR, AND FLUSH HINGES. TYPEWRITTEN INDEX SHALL BE MOUNTED ON DOOR INSIDE TRANSPARENT COVER INDICATING LOAD SERVED. PANELS SHALL INCLUDE SEPARATE EQUIPMENT GROUND BUS.
- CONDUIT RUNS AS SHOWN ON THE PLANS ARE DIAGRAMMATIC ONLY; EXACT LOCATION AND METHOD OF SUPPORT SHALL BE DETERMINED IN THE FIELD.
- CONTRACTOR SHALL CHECK EXISTING CONDITIONS TO DETERMINE EXACT EXTENT OF WORK TO BE PERFORMED PRIOR TO BIDDING. DIMENSIONS RELEVANT TO EXISTING WORK SHALL BE VERIFIED IN THE FIELD.
- PROVIDE AS-BUILT "CADD" DRAWINGS AT THE COMPLETION OF THE PROJECT.

ABBREVIATIONS

A	AMPERE	NTS	NOT TO SCALE
AF	AMPERE FRAME	PNL	PANELBOARD
AC	ALTERNATING CURRENT	PH	PHASE
AT	AMPERE TRIP	FL	FLOOR
ATS	AUTOMATIC TRANSFER SWITCH	FLA	FULL LOAD AMPERE
BKR	BREAKER	GC	GENERAL CONTRACTOR
C	CONDUIT	GFI	GROUND FAULT INTERRUPTER
CKT	CIRCUIT	GND	GROUND
CB	CIRCUIT BREAKER	IG	ISOLATED GROUND
EC	ELECTRICAL CONTRACTOR	JB	JUNCTION BOX
EMT	ELECTRIC METALLIC TUBING	KVA	KILOVOLT AMPERES
KW	KILOWATT	PVC	POLYVINYL CHLORIDE CONDUIT
MCB	MAIN CIRCUIT BREAKER	RSC	RIGID GALVANIZED STEEL CONDUIT
MLO	MAIN LUGS ONLY	XFMR	TRANSFORMER
MC	MECHANICAL CONTRACTOR	V	VOLTS
MTD	MOUNTED	W	WATTS OR WIRE
MTG	MOUNTING	WP	WEATHERPROOF
NMC	NON-METALLIC CONDUIT		
NA	NOT APPLICABLE		
NIC	NOT IN CONTRACT		

ELECTRICAL SYMBOL LIST

RECEPTACLES

- DUPLEX CONVENIENCE OUTLET RATED 20A, 125V, U-SLOT GROUNDED TYPE. ALL OTHER MOUNTING HEIGHTS SHALL BE AS NOTED ADJACENT TO THE SYMBOL. REFER TO RECEPTACLE ABBREVIATIONS FOR SPECIAL PURPOSE RECEPTACLES
- DUPLEX RECEPTACLE WITH INTERGRAL GROUND FAULT INTERRUPTER

RACEWAY AND WIRING

- HOMERUN TO PANELBOARD, NUMBER OF SLASH MARKS INDICATES NUMBER OF #12 AWG CONDUCTORS IN MINIMUM 3/4" CONDUIT. NO SLASH MARKS INDICATE 2#12 & 1#12G, 3/4" UNLESS NOTED OTHERWISE. -GREEN GROUND CONDUCTOR IS NOT INDICATED BUT SHALL BE INCLUDED IN EACH RACEWAY. SIZE SHALL BE #12 UNLESS INDICATED OTHERWISE. -HOMERUNS TO PANELBOARDS SHALL HAVE A MAXIMUM OF THREE PHASE CONDUCTORS (ONE PER PHASE) PLUS NEUTRAL AND GROUND CONDUCTOR IN EACH CONDUIT.
- NEW UNDERGROUND ELECTRIC LINE
- EXISTING UNDERGROUND ELECTRIC LINE
- EXISTING UNDERGROUND ELECTRIC LINE TO BE REMOVED

MISCELLANEOUS

- JUNCTION BOX WITH BLANK COVERPLATE, SIZE AS REQUIRED BY N.E.C.
- TIME CLOCK
- CONTACTOR
- ELECTRIC UTILITY BILLING METER
- EXISTING TO REMAIN
- EXISTING TO BE REMOVED
- PULL BOX/HANDHOLE SEE DETAIL 1 DRAWING EL103
- GROUND - SYSTEM AND/OR EQUIPMENT
- DIGITAL TIMER SWITCH

POWER DISTRIBUTION EQUIPMENT

- HAND HOLE
- CIRCUIT BREAKER 200AMP-3 POLE

LIGHTING

- SPORTS LIGHT POLE - 'F1' INDICATES POLE NUMBER 'C1' INDICATES CONTACTOR OR CONTRACTORS CONTROLLING POLE MOUNTED FIXTURES
- POLE MOUNTED LIGHT FIXTURE

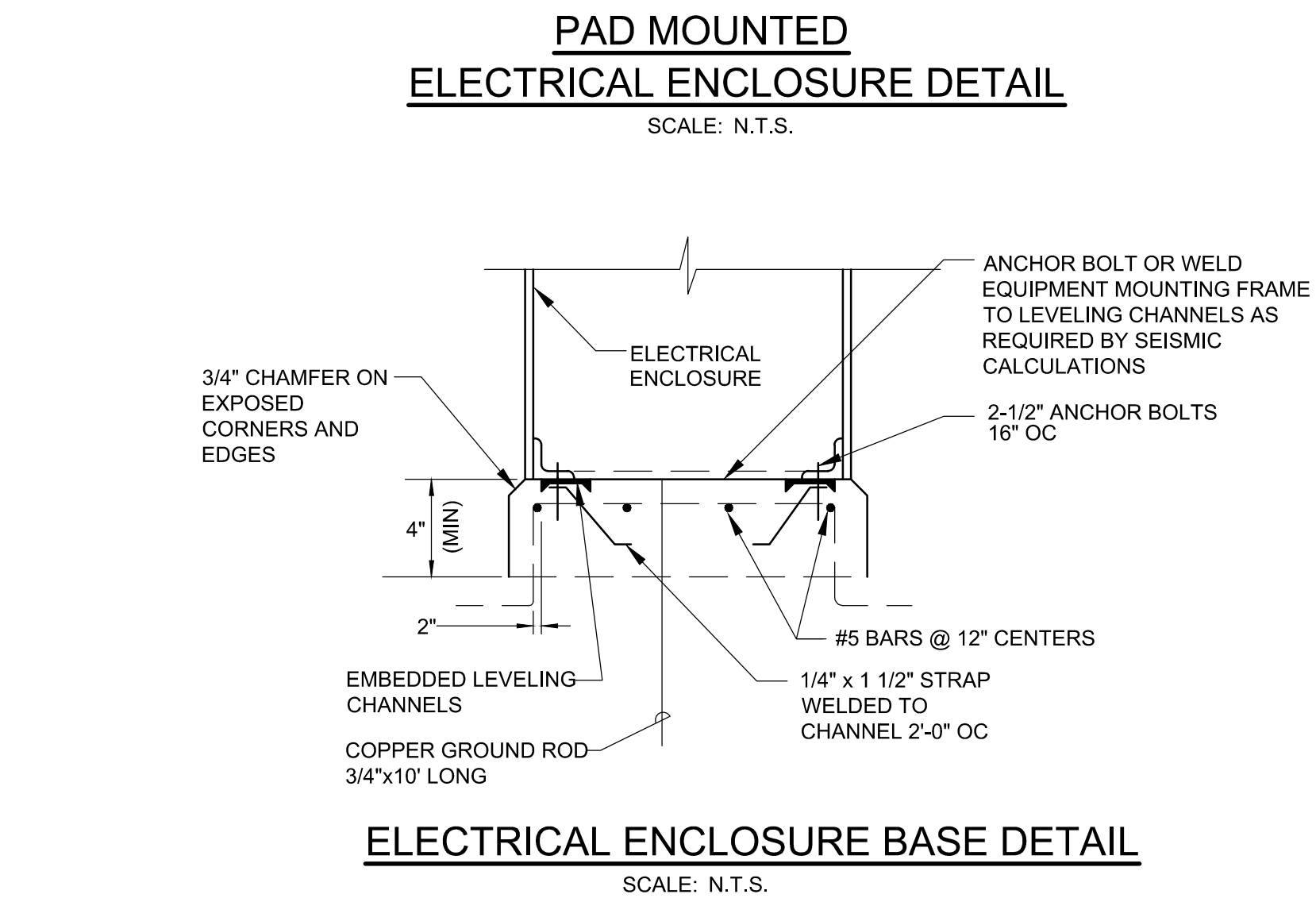
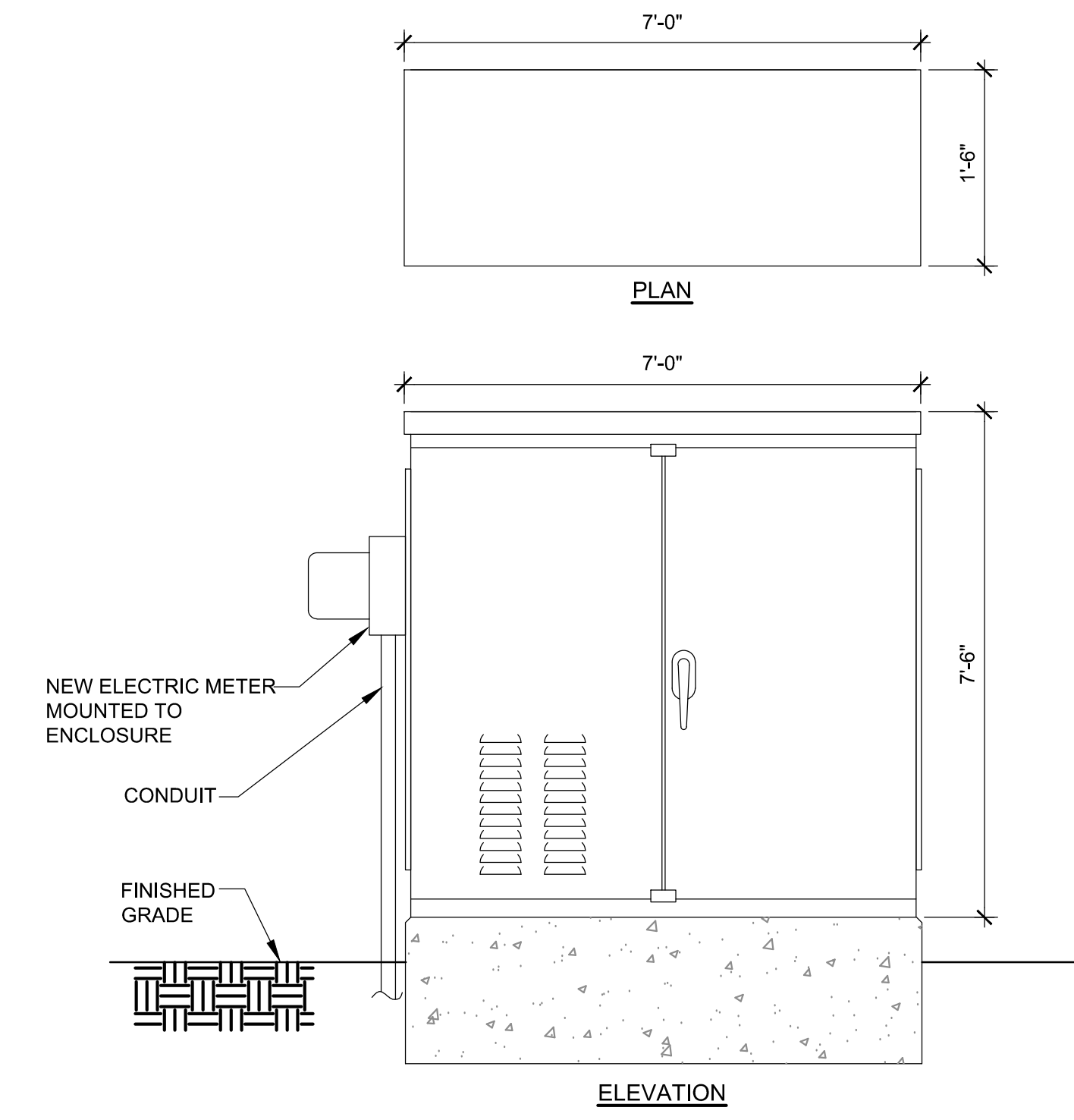
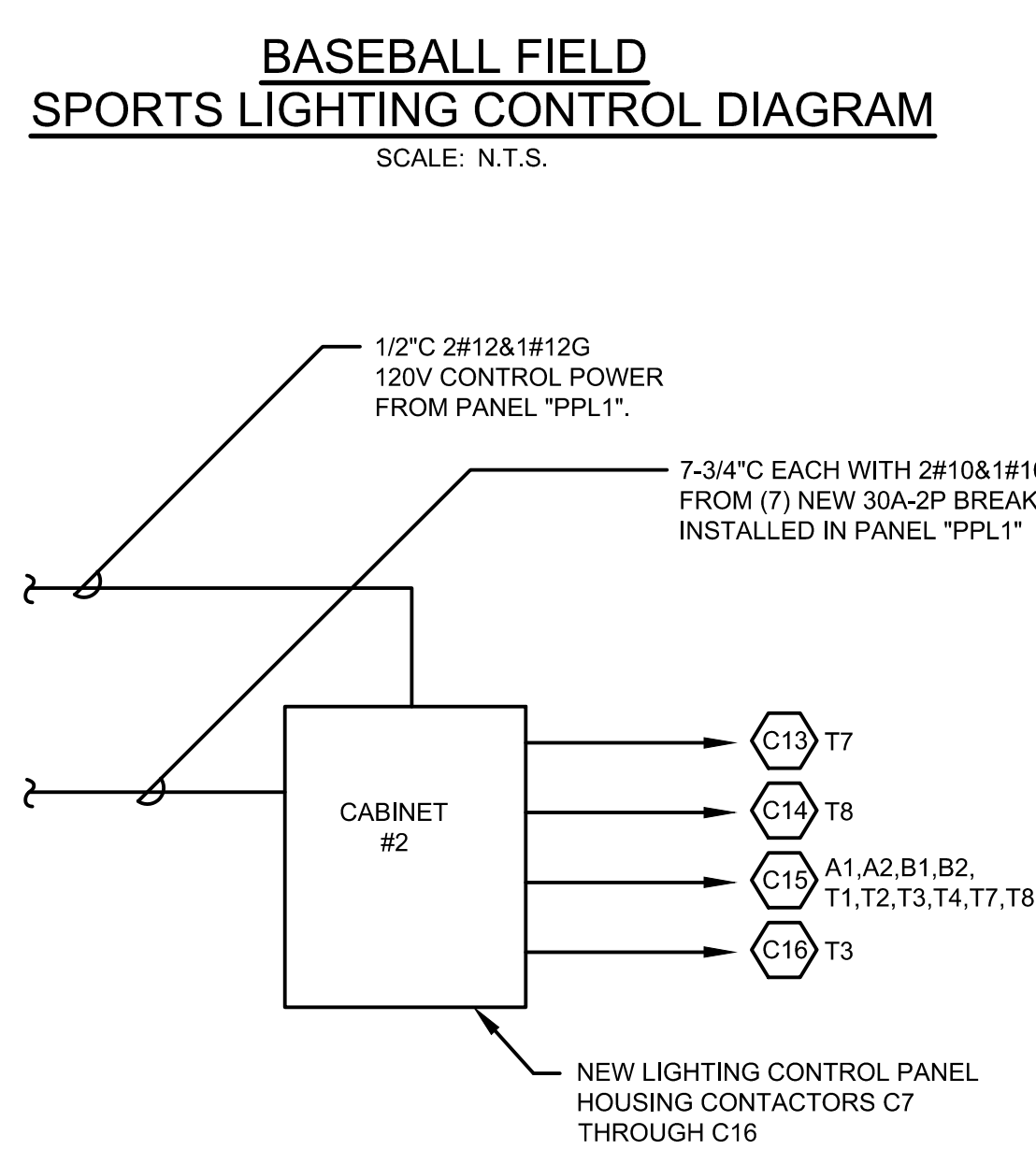
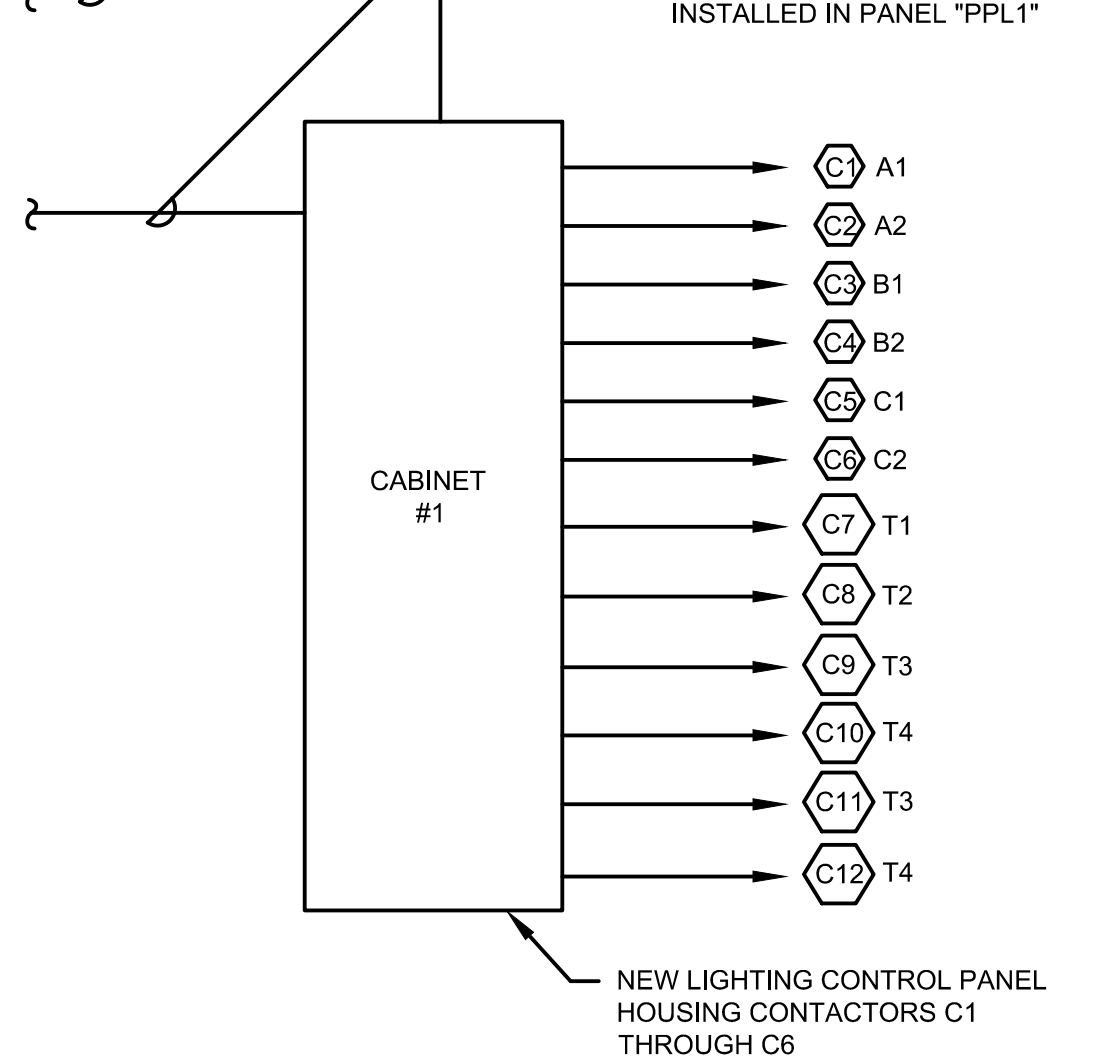
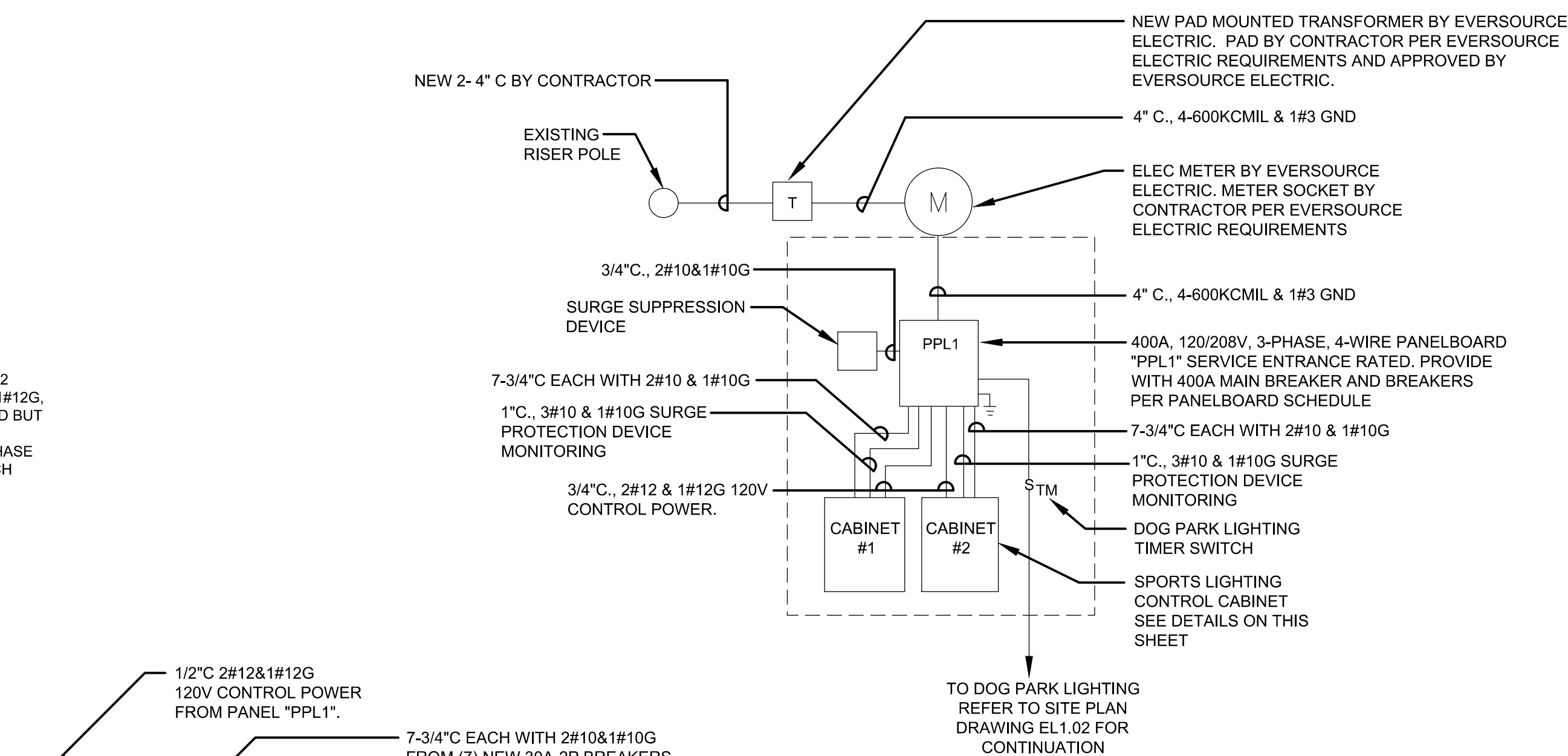
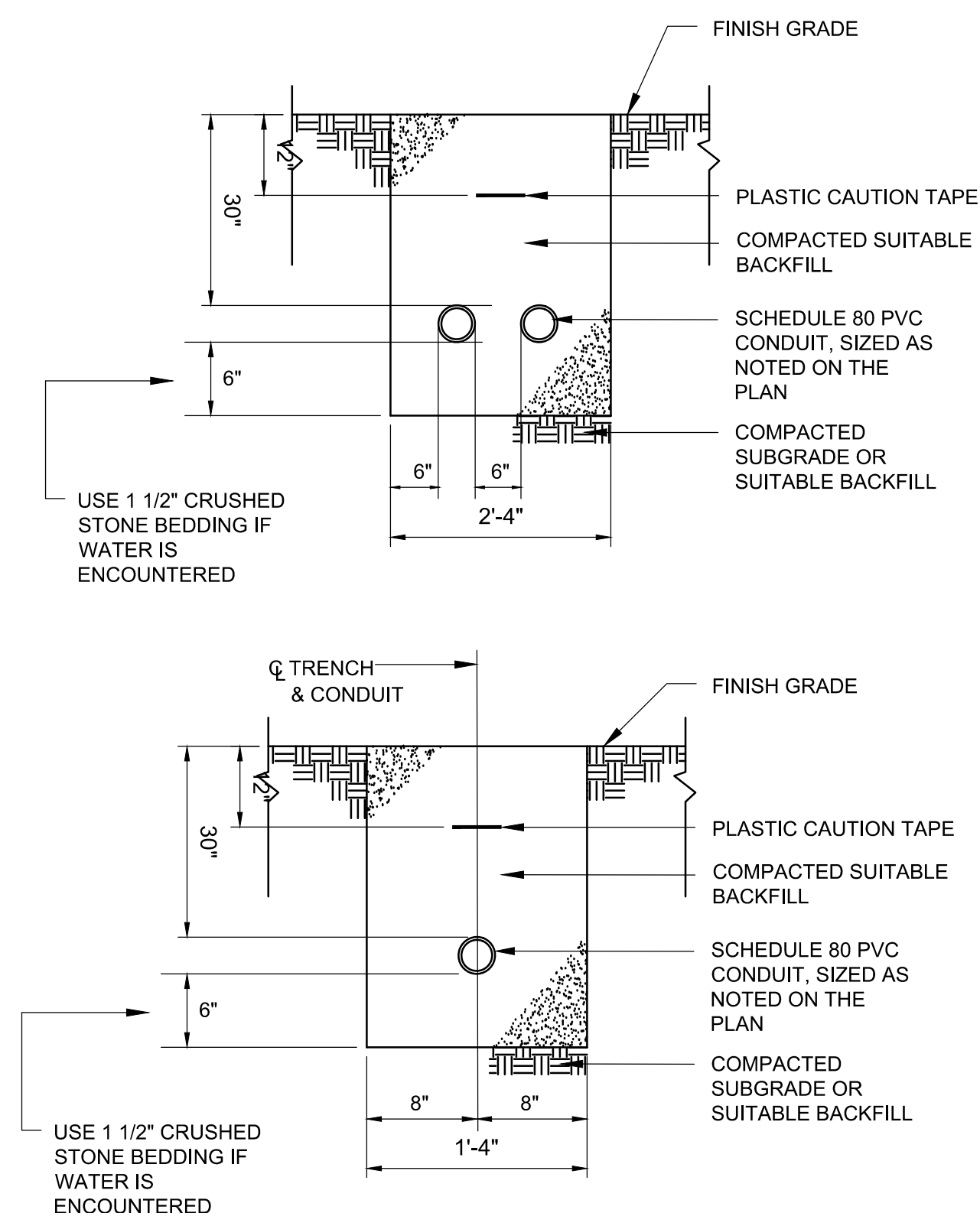

Project:
SOUTH MILL POND TENNIS COURTS

Rockland Street
Portsmouth, NH

Consultants:
Weston & Sampson
427 Main Street, Suite 400, Worcester, MA 01608
978-532-1900 (800) Sampson
www.westonandsampson.com

North:

Revisions:

Rev	Date	Description

Seal:

PLANS FOR CONSTRUCTION

Date: 09.18.2015
Scale: N.T.S.
Drawn By: CCC
Reviewed By:
Checked By:
Approved By:

Drawing Title:
ELECTRICAL LEGEND, ABBREVIATIONS, GENERAL NOTES AND DETAILS

Sheet Number:
EL1.00

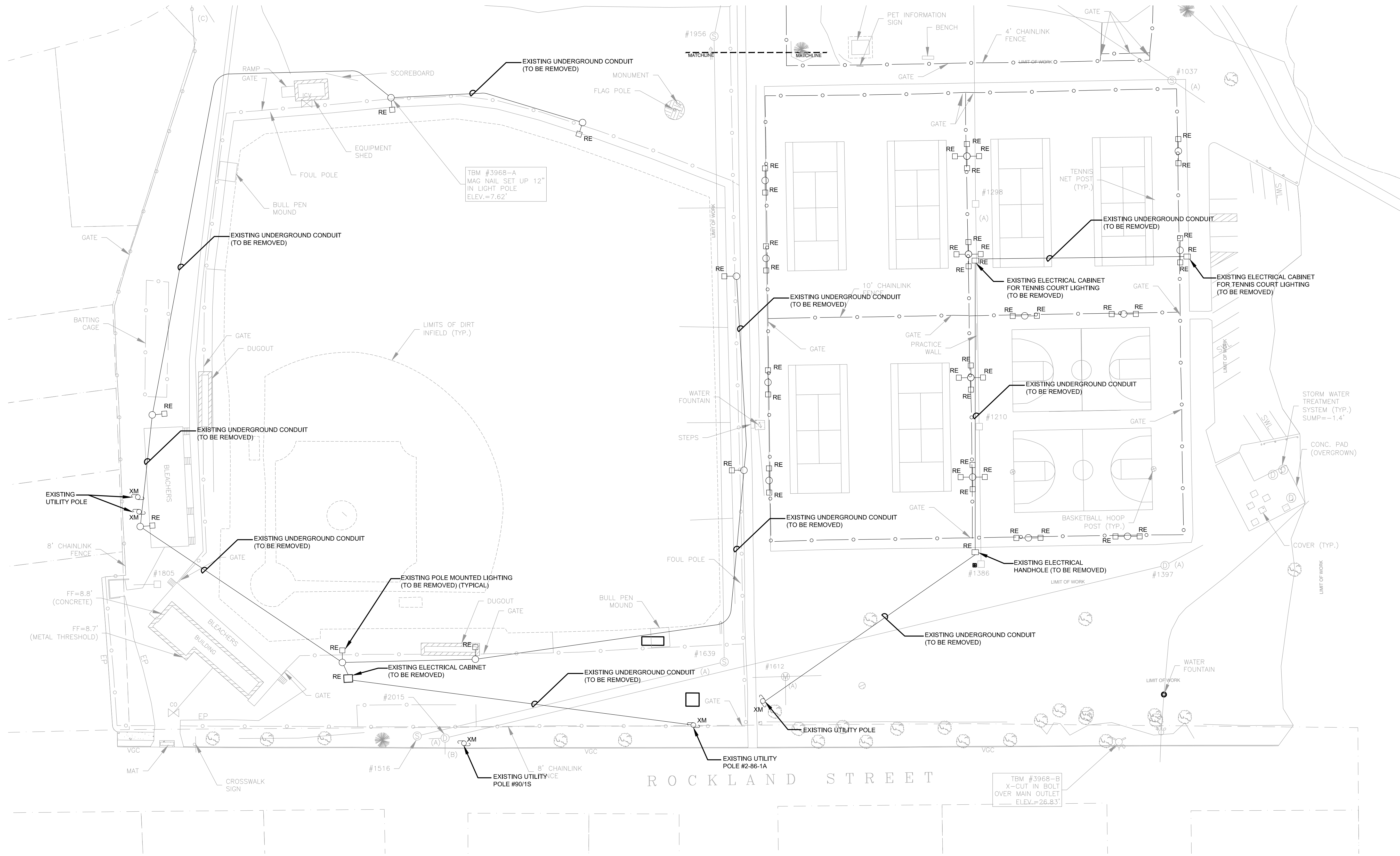

DEMO LEGEND	
XM	ELECTRICAL COMPONENTS IDENTIFIED AS (EX) SHALL REMAIN AS INSTALLED. BRANCH CIRCUITS SHALL REMAIN INSTALLED AND ACTIVATED. BRANCH CIRCUIT WIRING SERVING EQUIPMENT THAT IS TO REMAIN IN OPERATION THAT INTERFERES WITH THE NEW OR REQUIRES REMOVAL WHERE EXISTING CONSTRUCTION IS REMOVED SHALL BE MODIFIED AND REWORKED AS REQUIRED BY FIELD CONDITIONS ENCOUNTERED DURING THE RENOVATION PERIOD.
RE	ELECTRICAL COMPONENTS IDENTIFIED AS (RE) DENOTES COMPONENTS THAT ARE TO BE REMOVED. CONDUIT AND WIRE SERVING THE DEVICE IS TO BE REMOVED TO ITS POINT OF ORIGIN. DEVICES THAT OCCUR IN THE MIDDLE OF A CIRCUIT IS TO HAVE THE WIRING MODIFIED TO PROVIDE SERVICE TO THE REMAINING DEVICES.
RL	ELECTRICAL COMPONENTS IDENTIFIED AS (RL) DENOTES COMPONENTS THAT ARE TO BE REMOVED AND RELOCATED. CONTRACTOR TO EXTEND EXISTING BRANCH CIRCUIT WIRING TO NEW LOCATION.
RN	ELECTRICAL COMPONENTS IDENTIFIED AS (RN) DENOTES NEW LOCATIONS OF RELOCATED COMPONENTS. MODIFY AND EXTEND BRANCH CIRCUIT WIRING AS REQUIRED FOR SERVICE TO SAME.

- | DEMOLITION NOTES | |
|------------------|--|
| 1. | THE ELECTRICAL CONTRACTOR WILL WORK IN CONJUNCTION WITH THE GENERAL CONTRACTOR TO DEMOLISH THE EXISTING BALL FIELD AND TENNIS COURT LIGHTING SYSTEMS. THE ELECTRICAL CONTRACTOR IS TO DEACTIVATE, DISCONNECT AND REMOVE THE LIGHTING SYSTEMS WHICH WILL BE DEMOLISHED. THE ELECTRICAL CONTRACTOR WILL REMOVE AND DISPOSE OF ALL ELECTRICAL SYSTEM MATERIALS INCLUDING FIXTURES, RACEWAYS, CABLE AND APPURTENANCES. |
| 2. | PRIOR TO REMOVAL OF EQUIPMENT, CONFIRM THAT FEEDER AND BRANCH CIRCUITS ARE NO LONGER ACTIVE. SHOULD IT BE DISCOVERED THE FEEDER OR BRANCH CIRCUITS ARE ACTIVE, NOTIFY THE ARCHITECT IMMEDIATELY FOR DIRECTION. |
| 3. | ELECTRICAL CONTRACTOR IS TO REMOVE ALL AMPS, BALLASTS AND OTHER ELECTRICAL COMPONENTS CLASSIFIED AS HAZARDOUS MATERIALS. ELECTRICAL CONTRACTOR IS TO OBTAIN THE SERVICES OF A LICENSED HAZARDOUS MATERIALS CONTRACTOR TO DISPOSE OF THE MATERIALS. PROVIDE WRITTEN DOCUMENTATION TO THE OWNER'S REPRESENTATIVE FROM THE HAZARDOUS MATERIALS CONTRACTOR. |

Revisions:

Rev	Date	Description

Seal:
 Date: 09.18.2015
 Scale: 1" = 30'
 Drawn By: DNM
 Reviewed By:
 Checked By:
 Approved By:

**PLANS FOR
 CONSTRUCTION**

**ELECTRICAL SITE
 EXISTING CONDITIONS/
 DEMOLITION PLAN**

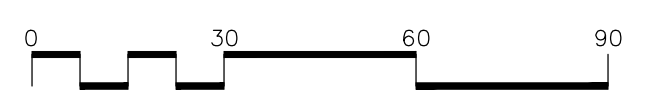

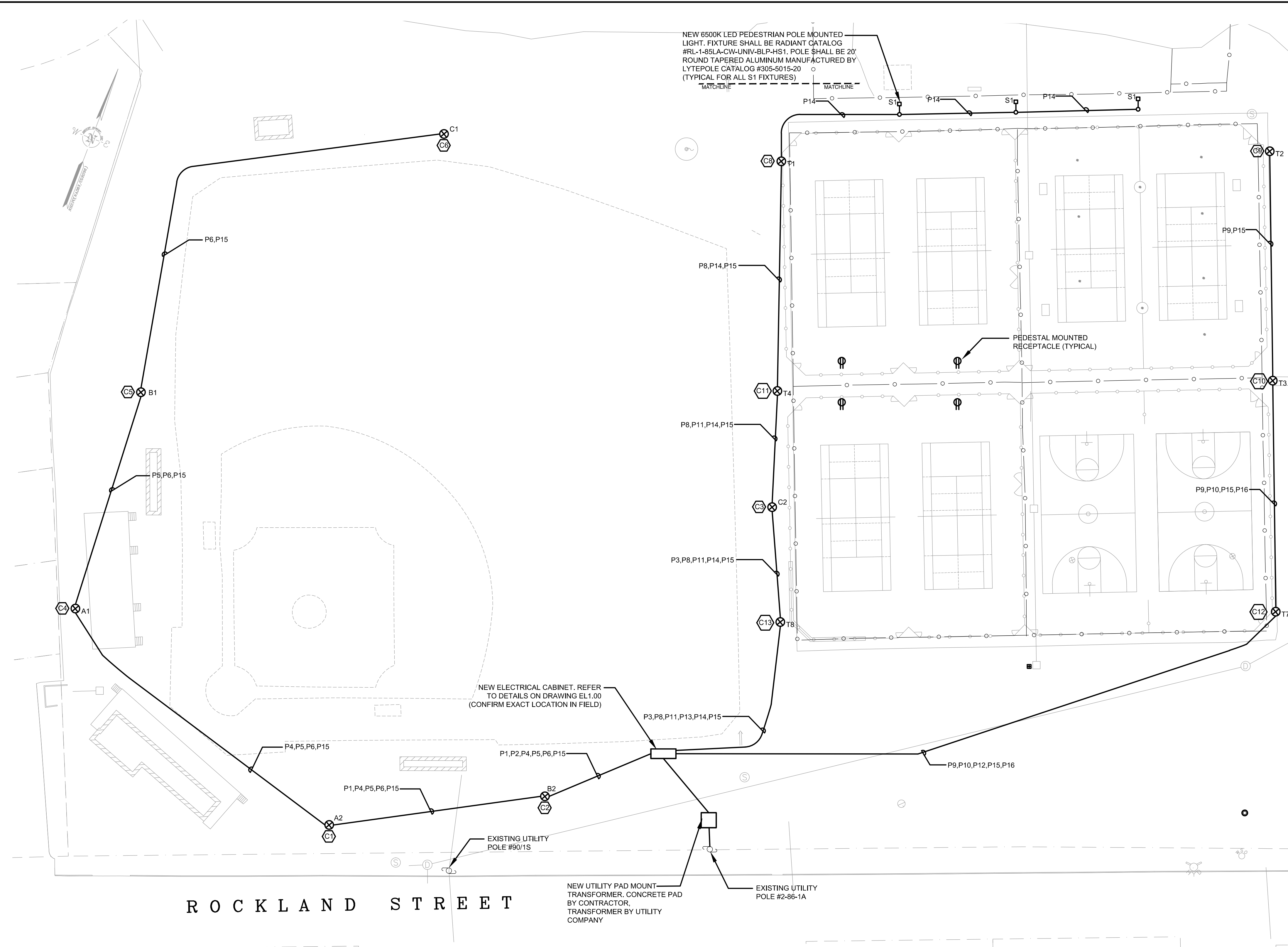

CONDUIT & WIRING SCHEDULE

CONDUIT	FEEDER	FROM	TO	FIXTURES	LOAD	REMARKS
P1	1-1/2" C., 3#4 & 1#8G	LIGHTING CONTROL PANEL CONTACTOR C2	FIXTURE A2	6 @ 1500W	34.4A	DIRECT BURIED
P2	1-1/2" C., 3#4 & 1#8G	LIGHTING CONTROL PANEL CONTACTOR C4	FIXTURE B2	8 @ 1500W	51.6A	DIRECT BURIED
P3	1-1/2" C., 3#4 & 1#8G	LIGHTING CONTROL PANEL CONTACTOR C6	FIXTURE C2	6 @ 1500W	34.4A	DIRECT BURIED
P4	1-1/2" C., 3#4 & 1#8G	LIGHTING CONTROL PANEL CONTACTOR C1	FIXTURE A1	6 @ 1500W	34.4A	DIRECT BURIED
P5	1-1/2" C., 3#4 & 1#8G	LIGHTING CONTROL PANEL CONTACTOR C3	FIXTURE B1	8 @ 1500W	51.6A	DIRECT BURIED
P6	1-1/2" C., 3#1 & 1#8G	LIGHTING CONTROL PANEL CONTACTOR C5	FIXTURE C1	6 @ 1500W	34.4A	DIRECT BURIED
P8	1-1/2" C., 3#4 & 1#8G	LIGHTING CONTROL PANEL CONTACTOR C7	FIXTURE T1	3 @ 1500W	17.2A	DIRECT BURIED
P9	1-1/2" C., 3#4 & 1#8G	LIGHTING CONTROL PANEL CONTACTOR C8	FIXTURE T2	3 @ 1500W	17.2A	DIRECT BURIED
P10	1-1/2" C., 3#4 & 1#8G	LIGHTING CONTROL PANEL CONTACTOR C9,C11,C16	FIXTURE T3	6 @ 1500W	17.2A	DIRECT BURIED
P11	1-1/2" C., 3#4 & 1#8G	LIGHTING CONTROL PANEL CONTACTOR C10,C12	FIXTURE T4	6 @ 1500W	17.2A	DIRECT BURIED
P12	1-1/2" C., 3#4 & 1#8G	LIGHTING CONTROL PANEL CONTACTOR C13	FIXTURE T7	3 @ 1500W	17.2A	DIRECT BURIED
P13	1-1/2" C., 3#4 & 1#8G	LIGHTING CONTROL PANEL CONTACTOR C14	FIXTURE T8	3 @ 1500W	17.2A	DIRECT BURIED
P14	1-1/2" C., 2#8 & 1#10G	PANEL PPL1-39	DOG PARK LIGHTING	3 @ 95W	2.38A	DIRECT BURIED
P15	1-1/2" C., 2#4 & 1#8G	LIGHTING CONTROL PANEL CONTACTOR C15	PEDESTRIAN FIXTURE A1,A2,B1,B2,C1,C2,T1,T2,T3,T4,T7,T8	20	10.64A	DIRECT BURIED
P16	1-1/2" C., 2#4 & 1#8G	LIGHTING CONTROL PANEL CONTACTOR C16	FIXTURE T3	1	3.84A	DIRECT BURIED

PANELBOARD SCHEDULE

PANELBOARD NO.: PPL1 SERVICE ENTRANCE RATED SERVICE: 120/208V, 3Ø, 4W/400A MCB

LOCATION: ELECTRICAL ENCLOSURE BUS BARS: 400A

MOUNTING: SURFACE AIC: 22,000 TOTAL NO. OF POLES: 42

CKT. No.	DESCRIPTION OF LOAD	CIRCUIT BREAKERS			DESCRIPTION OF LOAD	CKT. No.
		TRIP	POLES	TRIP		
1	-	-	-	-	-	2
3	BASEBALL FIELD LIGHTING A2/C2	60	3	3	60	4
5	-	-	-	-	-	6
7	-	-	-	-	-	8
9	BASEBALL FIELD LIGHTING C2/C6	60	3	3	60	10
11	-	-	-	-	-	12
13	-	-	-	-	-	14
15	BASEBALL FIELD LIGHTING B1/C3	60	3	3	60	16
17	-	-	-	-	-	18
19	-	-	-	-	-	20
21	TENNIS COURT LIGHTING T1/C7	30	3	3	30	22
23	-	-	-	-	-	24
25	-	-	-	-	-	26
27	TENNIS COURT LIGHTING T3/C9,C11,C16	30	3	3	30	28
29	-	-	-	-	-	30
31	-	-	-	-	-	32
33	TENNIS COURT LIGHTING T7/C13	30	3	3	30	34
35	-	-	-	-	-	36
37	PEDESTRIAN LIGHTING C15	30	1	1	20	38
39	DOG PARK LIGHTING	20	1	1	20	40
41	SPARE	20	1	1	20	42

* PROVIDE PANELBOARD WITH A GROUND BUS

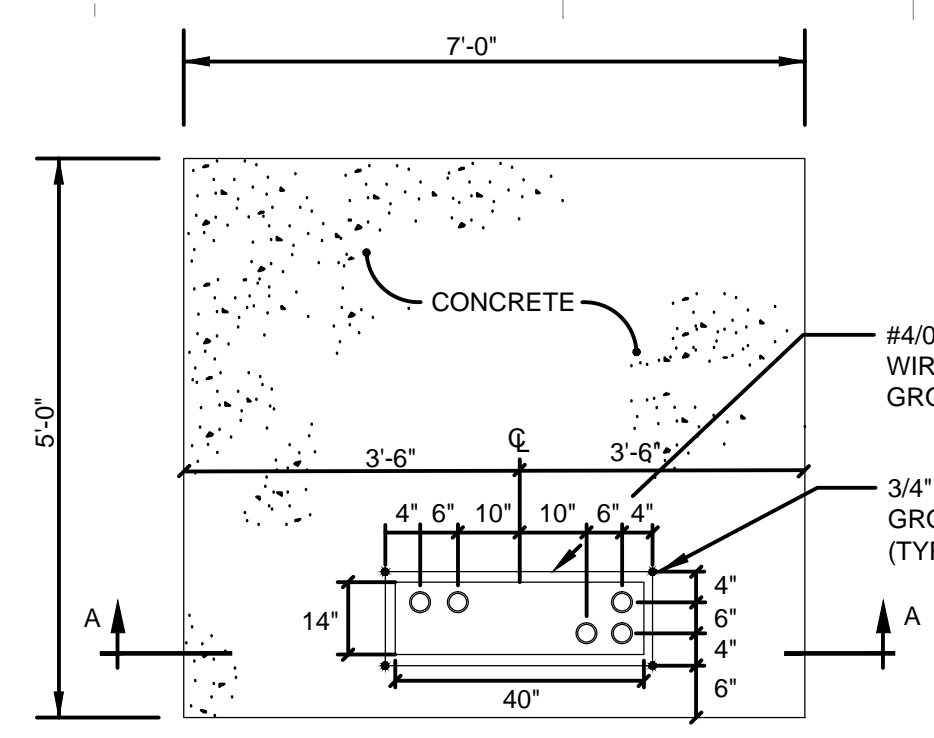

NOTE: CONTRACTOR SHALL COORDINATE ALL TRANSFORMER PAD DIMENSIONS AND REQUIREMENTS WITH EVERSOURCE ELECTRIC PRIOR TO INSTALLATION.

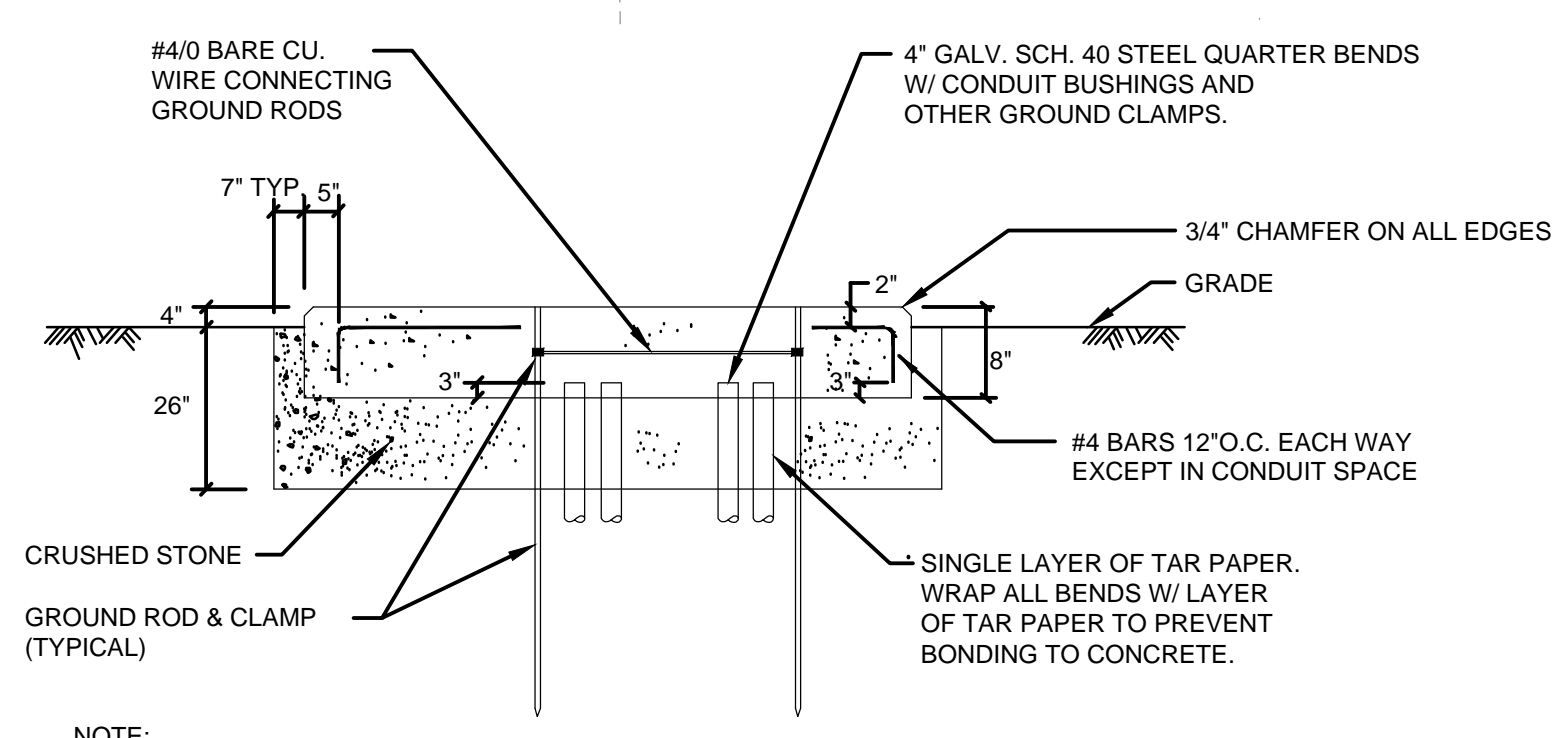

NOTE: PRIMARY AND SECONDARY CONDUITS SHALL BE 4" RIGID GALVANIZED STEEL.

3 TRANSFORMER PAD DETAIL
SCALE: N.T.S.

Project:
SOUTH MILL POND TENNIS COURTS

Rockland Street
Portsmouth, NH

Weston & Sampson
427 Main Street, Suite 400, Worcester, MA 01608
978-532-1900 (800) Sampson
www.westonandsampson.com

Consultants:

North:

Revisions:
Rev Date Description

Seal:

PLANS FOR CONSTRUCTION

Date: 09.18.2015
Scale: 1" = 30'
Drawn By:
Reviewed By:
Checked By:
Approved By:

Drawing Title:
ELECTRICAL SITE NEW WORK PLAN
Sheet Number:
EL1.02

