

City of Portsmouth
Portsmouth, New Hampshire
Planning Department

Bid #11-14
Bicycle Racks

INVITATION TO BID

Sealed bid proposals, **plainly marked** “City of Portsmouth Bicycle Racks – Bid #11-14 **on the outside of the envelope**, addressed to the Finance/Purchasing Department, City Hall, 1 Junkins Avenue, Portsmouth, New Hampshire, 03801, will be accepted until **July 12, 2013 @ 12:00 p.m.** at which time all bids will be publicly opened and read aloud.

Scope: The City of Portsmouth is seeking to purchase 40 bicycle racks.

This bid is available at <http://www.cityofportsmouth.com/finance/purchasing.htm> or by contacting the Finance/Purchasing Department at the following number: (603) 610-7227.

Questions may be directed to the Finance/Purchasing Department. Addenda to this proposal, if any, including written answers to questions, will be posted on the City of Portsmouth website under the project heading.

The City of Portsmouth reserves the right to reject any or all bids, to waive technical or legal deficiencies, and to accept any bid that it may deem to be in the best interest of the City.

INSTRUCTION TO BIDDERS**I. Preparation of Bid Proposal**

- A. The Bidder shall submit its proposal upon the form furnished by the City (attached). Prices shall be given in both words and figures.
- B. Corrections made to amounts or information requested on the bid form should be made by crossing out the error and entering the new price or information above or below it. The correction must be initialed. In case of discrepancy between the prices written in words and those written in figures, the prices written in words shall govern.
- C. The bidder's proposal must be signed by the individual, by one or more members of the partnership, by one or more members or officers of each firm representing a joint venture; by one or more officers of a corporation, or by an agent of the contractor legally qualified and acceptable to the owner. If the proposal is made by an individual, his/her name and post office address must be shown, by a partnership the name and post office address if each partnership member must be shown; as a joint venture, the name and post office address of each must be shown; by a corporation, the name of the corporation and its business address must be shown, together with the name of the state in which it is incorporated, and the names, titles, and business addresses of the President, Secretary, and Treasurer.
- D. All words, figures, corrections shall be in ink or typed. All signatures shall be in ink.
- E. Addenda to this proposal, if any, including written answers to questions, will be posted on the City of Portsmouth website at <http://www.cityofportsmouth.com/finance/purchasing.htm> under the project heading. Addenda and updates will NOT be sent directly to firms. Bidders submitting a proposal should check the web site for addenda and updates after the release date. Bidders should print out, sign and return addenda with the proposal. Failure to do so may result in disqualification.
- F. Disadvantaged Business Enterprises (DBEs) as defined in 49 CFR Part 26 are encouraged to submit a proposal. If applicable, documentation of DBE status shall be included with the submittal.

II. Delivery of Bid Proposals

When sent by mail, the sealed proposal shall be addressed to the owner at the address and in the care of the official in whose office the bids are to be received. All proposals shall be filed prior to the time and at the place specified in the invitation for bids. Proposals received after the time for opening of the bids will be returned to the bidder, unopened. Faxed bid proposals are not acceptable.

III. Withdrawal of Bid Proposals

A bidder will be permitted to withdraw his/her proposal unopened after it has been deposited if such request is received in writing prior to the time specified for opening the proposals.

IV. Public Opening of Bid Proposals

Proposals will be opened and read publicly at the time and place indicated in the invitation for bids. Bidders, their authorized agents, and other interested parties are invited to be present.

V. Irregular Proposals and Disqualification of Bidders

Bid proposals that are irregular may be rejected. Irregular bid proposals include the following:

- A. Failure to use the bid form provided or alteration of the form.
- B. Unauthorized additions, conditional or alternated bids, incomplete bids, or irregularities of any kind which may tend to make the proposal incomplete, indefinite or ambiguous as to its meaning.
- C. The addition of any provision reserving the right to accept or reject an award, or to enter into a contract pursuant to an award.

Bidders may be disqualified and the bid proposal rejected for the following reasons:

- A. More than one proposal for the same work from an individual, firm, or corporation under the same or different name;
- B. Evidence of collusion among bidders;
- C. Failure to submit all required information requested in bid specifications;
- D. Bidder is not qualified or able to provide the services or product(s) described in the bid specifications; or
- E. Disqualification is in the best interest of the City of Portsmouth.

AWARD

I. Consideration of Proposals and Award

After the proposals are opened and read, bid results will be available to the public. In case of discrepancy between the prices written in words and those written figures, the prices written in words shall govern.

Within 30 calendar days after the opening of proposals, if an award is made, it will be made to the lowest, responsible, qualified bidder whose proposal complies with all the requirements prescribed. The successful bidder will be notified by mail at the address indicated on the proposal.

The award shall not be considered official until such time that a purchase order, fully executed contract or an award letter has been issued by the Finance Director. No presumption of award shall be made by the bidder until such documents are in hand. Verbal notification of award is not considered official. Any action by the bidder to assume otherwise is done so at his/her own risk and the City will not be held liable for any expense incurred by a bidder that has not received an official award.

III. Reservation of Rights

The City reserves the right to cancel the award at any time before final notification of the successful bidder without any liability against the City. The City of Portsmouth reserves the right to reject any or all bids, to waive technical or legal deficiencies, and to accept any bid that it may deem to be in the best interest of the City.

BID SPECIFICATIONS

1. The design for bicycle racks shall be based on U/2 Inverted-U Rack Vintage Racks (part #12140G or 12140S) by Cycle-Safe, Inc., 4630 Ada Drive, Suite B, Ada, MI 49301, (888)-950-6531 or City-approved equal.
2. Furnished material shall be:
 - 1-1/2" SCHD, 40 PIPE (1.50" I.D.), rolled in the shape of an inverted "U" to 12" outside radius standing 36" high.
 - Vintage inlay design to be ¼ steel plate, laser-cut.
 - Coating to be TGIC Polyester powder coat.
 - Standard Color – Black.
 - Texture – regular grain.
 - Gloss – semi-gloss.
 - Tensile Strength – 1800 PSI min.
 - Resistance to abrasion.
 - Salt Spray Resistance to >2000 hours.
 - Hardness (Shore D) ASTMD 2240 – Results 52.
3. The installation options for these racks shall be as follows:
 - 28 surface-mount (S)
 - 12 channel rail-mount (R)
4. The City shall be responsible for installation.

BID PROPOSAL FORM

Total Bid: \$_____ \$_____

 Amount in Words Amount in Figures

DELIVERY: Bidder must state approximate number of days from award that delivery will be made. Not to exceed 30 days.

Of days for delivery: _____.

Delivery Address is: 680 Peverly Hill Rd, Portsmouth, NH 03801 Attn: Mark C. Nelson

The undersigned agrees that he/she on behalf of Bidder has read the bid proposal documents, the instruction to bidders and the bid specifications, and agrees to the terms and conditions set forth herein. Bid price shall be firm for at least 30 days.

Bidder further agrees that this bid is not made jointly or in conjunction, cooperation or collusion with any person, firm, corporation or other legal entity.

Bidder agrees no officer, agent or employee of the Owner is directly or indirectly interested in this Bid.

Submitted by Authorized Agent:

(Print Name & Title)

Signature: _____

Date: _____

Company: _____

Address: _____

City/State/Zip: _____

Telephone: _____

Fax: _____

Email: _____



CycleSafe[®]
SECURE BICYCLE PARKING

Vintage Racks[™] by: **cycle-safe**

*The charm of yesteryear.
The performance of tomorrow.*

Vintage Racks by Cycle-Safe are a novel blend of the old and the new. They capture the charm of traditional ornamental bicycle stands. Yet they incorporate leading-edge technologies to meet contemporary performance standards.

Vintage Racks were developed in response to urban planners' efforts to recreate historic streetscapes as counterpoints to the hustle and bustle of the modern world. Vintage Racks perfectly complement these restoration projects - both as decorative art pieces and as a means to encourage and accommodate eco-friendly transportation.

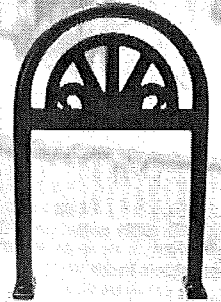

The Paris

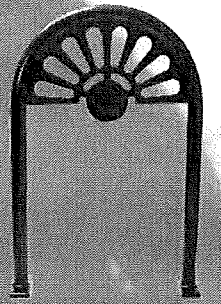

The Plymouth

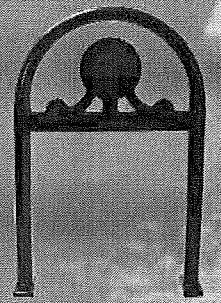

The Lafayette

THE PEARL

In-ground Rack # 12180G
Surface-Mount # 12180S

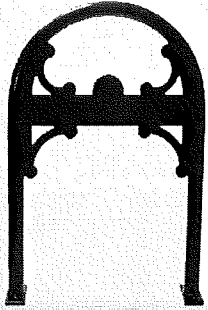

THE PLYMOUTH

In-ground Rack # 12140G
Surface-Mount # 12140S

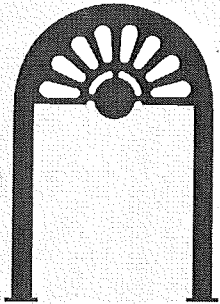

THE MADISON

In-ground Rack # 12130G
Surface-Mount # 12130S

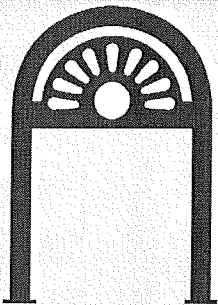

THE LAFAYETTE

In-ground Rack # 12150G
Surface-Mount # 12150S

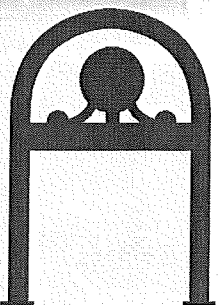

Vintage Racks™

by: cycle-safe

From the leader in secure bicycle parking.

For more than 20 years, Cycle-Safe has revolutionized bicycle parking with breakthrough designs, materials and technologies. Cycle-Safe installations are located worldwide, on city streets and university campuses, in office parks and shopping centers, at park & ride lots, and more. For variety, longevity and dependability, Cycle-Safe has no equal.

Superior design for better safety.

The inverted U is the most universally acknowledged design for efficient bicycle racks. Cycle-Safe Vintage Racks offer superior cycle frame support and stability characteristic of this design. The smooth lines of Cycle-Safe's one-bend U racks are also safer for pedestrian traffic around bike parking.



Durable and maintenance-free.

Cycle-Safe Vintage Racks are completely covered with TGIC Polyester powder coat with E-coat primer over Schedule 40 steel pressure pipe. This ensures maximum corrosion-resistance, impact-resistance, and UV stability to provide a maintenance free finish.

THE PLYMOUTH
Surface Mount # 12140S

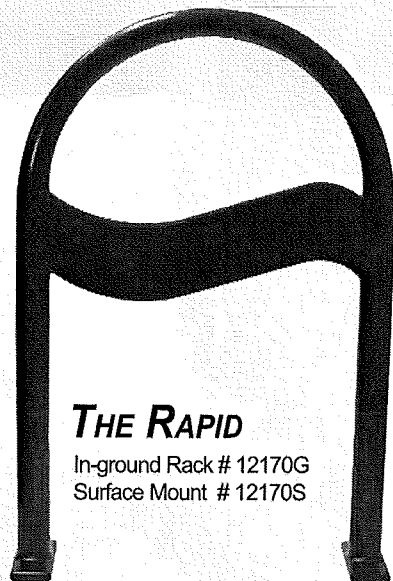

THE RAPID

In-ground Rack # 12170G
Surface Mount # 12170S

In-ground Installation

This is the standard for new construction and the most secure type of inverted-U installation. Can easily be installed in existing locations by drilling a 3"-4" core and grouting.

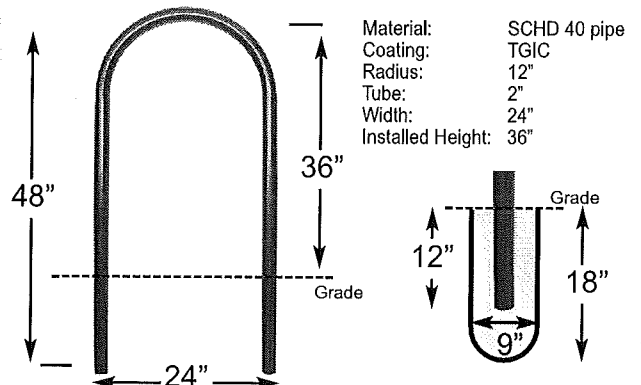

To download product specifications
go to cyclesafe.com
or call 888-950-6531

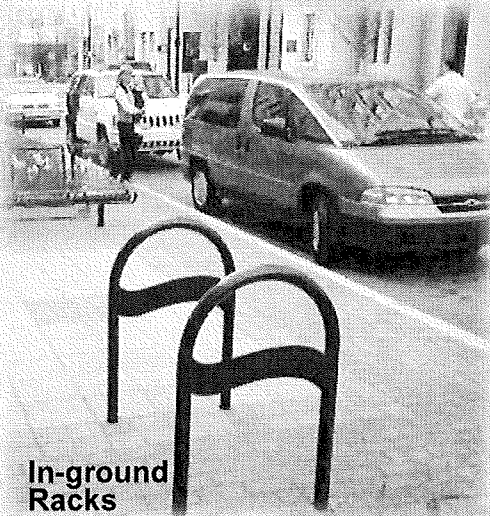

**In-ground
Racks**

- Unique Vintage Designs
- Low minimums to order (qty. 6)
- No Custom Set-ups
- Maintenance-free coating
- Meets all industry standards
- Capacity is 2 bicycles per rack

A pleasure to behold.

Originally designed for historic restoration projects, Cycle-Safe Vintage Racks are now being used as functional art in all manner of urban landscapes. Custom racks (see back page) provide even greater aesthetic flexibility. Custom colors are also available. All these rack choices may qualify for "1% for Art" public funding.



**Surface-Mount
12160S**

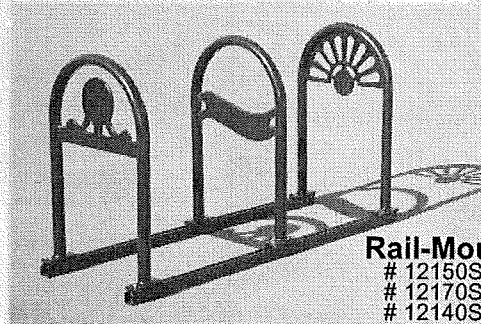

**Rail-Mount
12150S
12170S
12140S**

Rails can be obtained in 6 ft. and 12 ft. length and are fully coated.

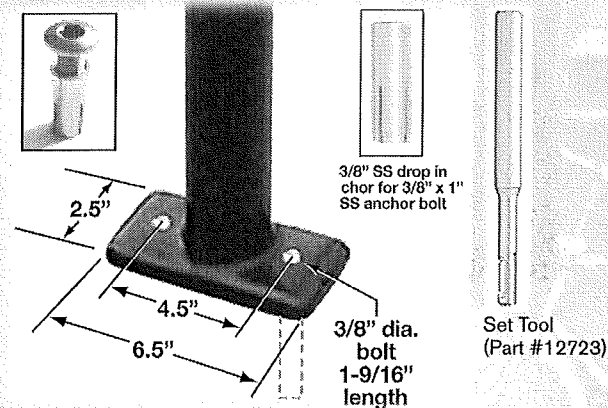

Surface Mount

NEW EXCLUSIVE! Our recommended Item #12718, 3/8" x 4" Torx Tamper-resistant button head concrete screw (shown).

Hardware Kit-G (Part #12716)



THE PARIS
Surface Mount # 12193S

THE PARIS

In-ground Rack # 12193G
Surface-Mount # 12193S

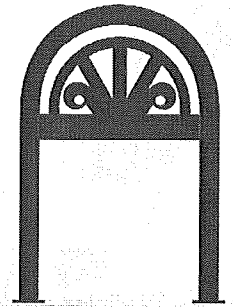

THE BRETON

In-ground Rack # 12133G
Surface-Mount # 12133S

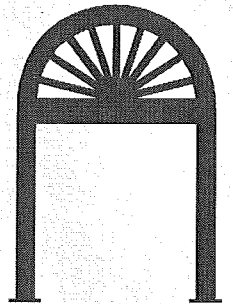

THE FULTON

In-ground Rack # 12190G
Surface-Mount # 12190S

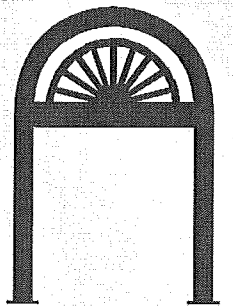

THE CASCADE

In-ground Rack # 12160G
Surface-Mount # 12160S

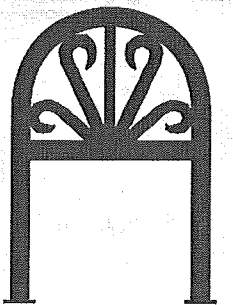

Cycle-Safe Maintenance-Free One-Bend Bike Racks

CUSTOM RACKS *by: cycle-safe*

Visit our Web site for custom images...cyclesafe.com



Turn your bike rack into a promotion with our exclusive racks. Display your corporate or community logo with laser-cut stainless steel made to your specifications, or use screen-printed images. Call for details on custom racks.

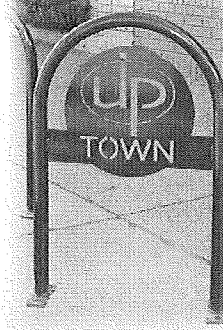

Cycle-Safe bicycle racks are designed to provide safety for users and to encourage cycling. The Cycle-Safe engineering team has developed three variations for installation to accommodate your needs; In-ground, Surface-Mount, or Rail-Mount.

How to Specify Bicycle Racks

Bicycle rack part # _____ (add Vintage style part#), as manufactured by Cycle-Safe, Inc., 888-950-6531. There is no equal.

Furnished Material Shall be:

- 1-1/2" SCHD, 40 PIPE (1.50" I.D.), rolled in the shape of an inverted "U" to a 12" outside radius standing 36" high.
- Vintage inlay design to be 1/4 steel plate, laser-cut.
- Coating to be TGIC Polyester powder coat.
- Standard Color – Black.
- Texture – regular grain.
- Gloss – semi-gloss.
- Tensile Strength – 1800 PSI min.
- Resistance to abrasion.
- Salt Spray Resistance to >2000 hours
- Hardness (Shore D) ASTM D 2240 - Results 52.
- Installation Options: In-ground (G), Surface-mount (S), Rail-mount (R)

Installation Layouts and Space Requirements:

Based on recommendations from the Association of Pedestrian and Bicycle Professionals and over 30 years in the bike parking industry, the following diagrams show typical configurations and space allowances for installations of multiple bike racks.

The minimum space between each rack is 3'0", more if possible to allow for ease of access. Aisles separate the rows of racks, with a minimum between aisles to be 4'-6", to allow for one person to walk one bike. In high traffic areas, the recommended aisle width is 6'-0". Aisle widths are measured tip to tip of bike tires between the rows of racks. Six feet should be allowed for each row of parked bicycles. Conventional upright bicycles are just less than 72 inches long, with handlebar widths varying from 22"-27" and can be easily accommodated with these recommended spacings.

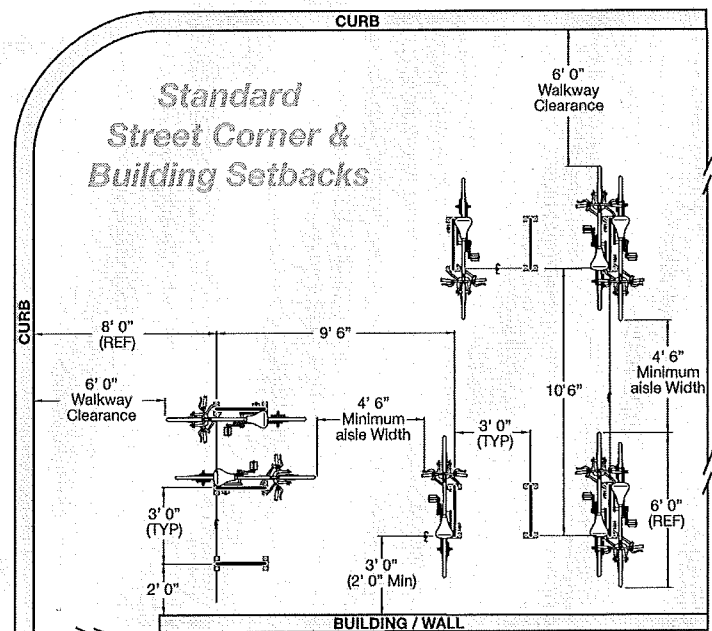

Download complete specifications for each rack in Word format from our web site cyclesafe.com
Vintage Bike Rack Series protected under US/Canadian Design Patents and Patents Pending.



Cycle-Safe, Inc. also manufactures bike lockers and a wide range of bicycle locker accessories. Please call or visit our web site cyclesafe.com for details.

888-950-6531 • Fax: (616) 954-0290
E-mail: info@cyclesafe.com
Website: cyclesafe.com