

CITY OF PORTSMOUTH
PUBLIC WORKS DEPARTMENT

DESIGN DATA	
AVERAGE DAILY TRAFFIC 2007	8,300
DESIGN SPEED	35 MPH
LENGTH OF PROJECT	0.25 MILES

SAGAMORE BRIDGE REPLACEMENT

(NH ROUTE 1A / SAGAMORE CREEK)

BRIDGE NO. 198/034

PORTSMOUTH, NEW HAMPSHIRE
STATE PROJECT NUMBER: 14493
FEDERAL AID PROJECT NUMBER: X-A000(417)

Prepared for:
CITY OF PORTSMOUTH
PUBLIC WORKS DEPARTMENT
ENGINEERING DIVISION
680 PEVERLY HILL ROAD
PORTSMOUTH, NEW HAMPSHIRE 03801

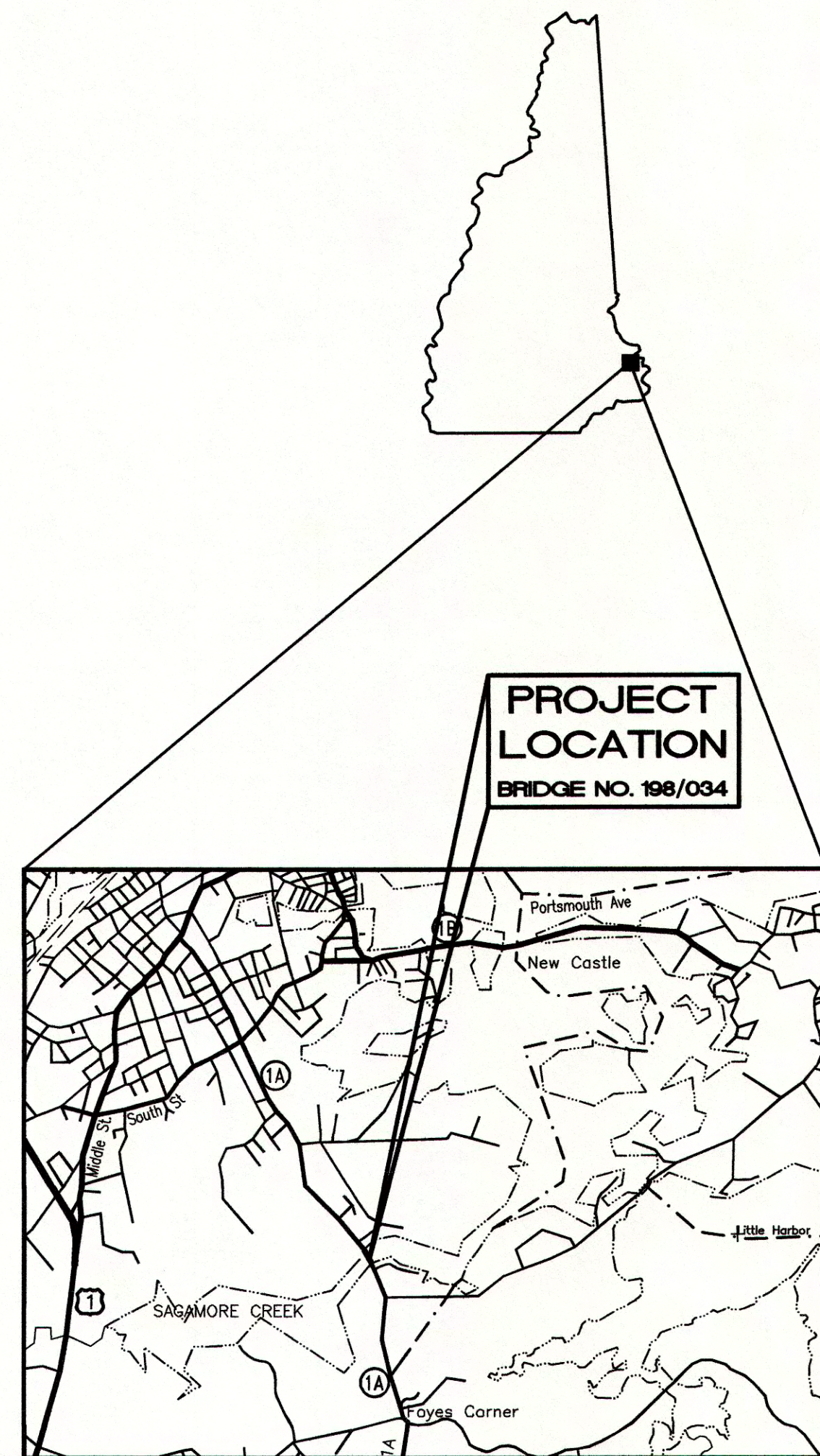

LOCATION PLAN
SCALE: 1" = 1/2 MILE

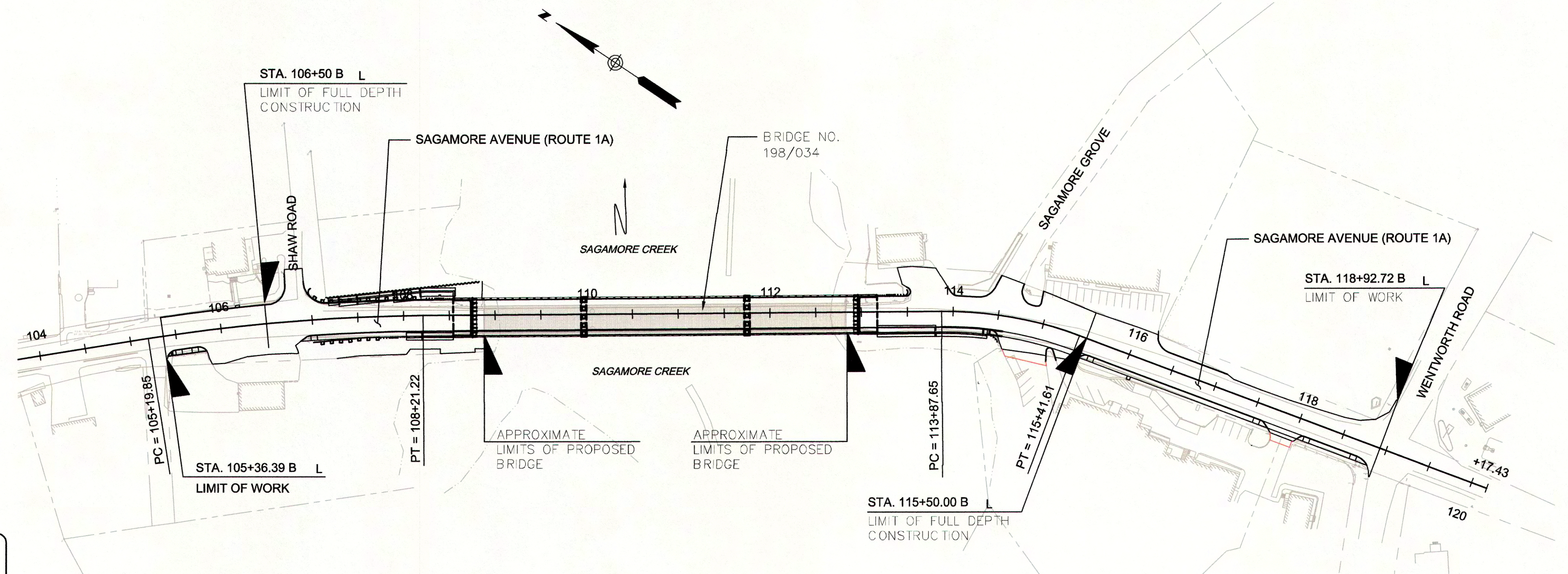

CITY OF PORTSMOUTH
COUNTY OF ROCKINGHAM
SCALE: 1" = 80'

DRAWN BY: ASW DATE: 4/13
CHECKED BY: DEM DATE: 4/13

CIVIL PLANS PREPARED BY:

ENGINEERS FST
Since 1914

FAY, SPOFFORD & THORNDIKE, LLC
ENGINEERS PLANNERS SCIENTISTS LANDSCAPE ARCHITECTS
288 SOUTH RIVER ROAD, BUILDING C, BEDFORD, NH 03110
TEL (603) 869-2000 FAX (603) 868-2670

STAMP:

STRUCTURAL PLANS PREPARED BY:

ENGINEERS FST
Since 1914

FAY, SPOFFORD & THORNDIKE, LLC
ENGINEERS PLANNERS SCIENTISTS LANDSCAPE ARCHITECTS
288 SOUTH RIVER ROAD, BUILDING C, BEDFORD, NH 03110
TEL (603) 869-2000 FAX (603) 868-2670

STAMP:

FEDERAL PROJECT NO.	STATE PROJECT NO.	SHEET NO.	TOTAL SHEETS
X-A000(417)	14493	1	91

INDEX OF SHEETS

SHEET NO.	DESCRIPTION
1	TITLE PAGE
2	INDEX OF SHEETS & GENERAL NOTES
3-4	STANDARD SYMBOLS
5-6	TYPICAL SECTIONS OF IMPROVEMENT
7-9	SUMMARY OF QUANTITIES
10-11	MISCELLANEOUS DETAILS
12	WATERMAIN DETAILS
13	DRIVEWAY DETAILS
14	CURB RAMP DETAILS
	<u>BRIDGE AND RETAINING WALL PLANS</u>
15-55	BRIDGE AND RETAINING WALL PLANS
	<u>ROADWAY PLANS</u>
56-58	GENERAL PLANS
59	DRAINAGE NOTES
60-62	PROFILES
63-65	CURBING & ALIGNMENT PLANS
66-68	PAVEMENT MARKING & SIGNAGE PLAN
69-70	WATER MAIN REPLACEMENT PLANS
71	EROSION AND SEDIMENTATION CONTROL PLAN
	<u>TRAFFIC CONTROL PLANS</u>
72	SITE STAGING PLAN
73	DETOUR PLAN
74	DETOUR SIGN SUMMARY
	<u>CROSS SECTIONS</u>
75-91	SAGAMORE AVE

THE FOLLOWING GENERAL NOTES
WILL BE USED ON THIS PROJECT:

1	2	3	4	5	6	7	8	9	10	11	12
13	14	15	16	17	18	19	20	21	22	23	24
25	26	27	28	29	30	31	32	33	34	35	36

GENERAL NOTES

- 1 FOR STANDARD PLANS, SEE "STANDARD PLANS FOR ROAD AND BRIDGE CONSTRUCTION", DATED 2001 (A BOUND BOOK).

- 2 HIGH TENSION OVERHEAD TRANSMISSION LINES ARE LOCATED THROUGHOUT THE PROJECT WITH CROSSINGS AT VARIOUS LOCATIONS AND RUNNING ALONG THE ROAD THROUGHOUT THE PROJECT EVEN ON REGULAR POLES. THE CONTRACTOR IS ADVISED THAT EXTREME CAUTION WILL BE REQUIRED IN THE OPERATION OF EQUIPMENT, ESPECIALLY CRANES AND PILE DRIVING EQUIPMENT.

- 3 REMOVE TOPSOIL FOR ITS TOTAL DEPTH WITHIN THE LIMITS OF THE SLOPE LINES. UNLESS OTHERWISE DIRECTED, STOCKPILE TOPSOIL AND USE IT ON THIS PROJECT AS NEEDED UNDER SECTION 641 - LOAM AND/OR SECTION 647 - HUMUS.

- 4 REMOVAL OF EXISTING CONCRETE PAVEMENT WILL BE PAID UNDER ITEM 203.2 - ROCK EXCAVATION. THE BITUMINOUS PAVEMENT ABOVE THE CONCRETE WILL NOT BE PAID UNDER ITEM 203.2.

- 5 MODIFY SUPERELEVATION ON EXISTING CURVES BY THE USE OF A PAVEMENT LEVELING COURSE TO THE RATES INDICATED ON THE PLANS OR AS ORDERED.

- 6 EXISTING DELINEATORS AND WITNESS MARKERS THAT ARE REMOVED AND DETERMINED BY THE ENGINEER TO BE IN ACCEPTABLE CONDITION SHALL BE RESET (SUBSIDIARY). ADDITIONAL DELINEATORS AND WITNESS MARKERS ORDERED WILL BE PAID UNDER THE APPROPRIATE ITEMS OF THE CONTRACT.

- 7 NO EXISTING MONUMENTS, BOUNDS, OR BENCHMARKS SHALL BE DISTURBED WITHOUT FIRST MAKING PROVISIONS FOR RELOCATION.

- 8 PERFORM ALL WORK WITHIN THE EXISTING RIGHT-OF-WAY, UNLESS OTHERWISE SHOWN ON THE PLANS OR AS ORDERED BY THE ENGINEER.

- 9 REMOVE UNPROTECTED PROJECT MARKERS (SUBSIDIARY).

- 10 SURVEY DATA FOR THIS PROJECT WAS PREPARED FROM AN ACTUAL ON THE GROUND FIELD SURVEY CONDUCTED BY WSP SELLS FROM JANUARY 22, 2010 TO FEBRUARY 19, 2010. COORDINATES ARE NEW HAMPSHIRE STATE PLANE COORDINATES OF N.A.D. 1983 AND THE VERTICAL DATUM SHOWN HEREON REFERENCES NAVD88.

- 11 QUANTITIES FOR EMBANKMENT AND EXCAVATION FOR SLOPE ROUNDINGS AS SHOWN ON THE TYPICALS HAVE NOT BEEN CALCULATED AND ARE NOT INCLUDED IN THE QUANTITY SUMMARIES AND ARE CONSIDERED SUBSIDIARY TO THE APPROPRIATE 203 ITEMS.

- 12 THE CONTRACTOR SHALL TAKE ALL NECESSARY MEASURES TO ENSURE THAT DEBRIS DOES NOT FALL INTO THE WATERWAY BELOW THE EXISTING STRUCTURE. ALL COSTS SHALL BE PAID UNDER ITEM 502, REMOVAL OF EXISTING BRIDGE STRUCTURE.

- 13 NO SCAFFOLDING SHALL BE ERECTED OR OPERATIONS CONDUCTED IN THE WATERWAY, UNLESS APPROVED BY THE CONTRACT ADMINISTRATOR.

- 14 NO CLEARING IS ALLOWED ALONG THE BANKS OF THE WATERWAY.

- 15 DURING REMOVAL AND REPAIR OPERATIONS, EXTREME CARE SHALL BE TAKEN NOT TO DAMAGE EXISTING STRUCTURAL STEEL AND REINFORCING STEEL THAT IS TO REMAIN IN PLACE. ANY DAMAGE SHALL BE IMMEDIATELY REPORTED TO THE ENGINEER AND REPAIRED AS DIRECTED, AT THE CONTRACTOR'S EXPENSE.

- 16 THE CONTRACTOR SHALL MEET OSHA REQUIREMENTS FOR WORKER PROTECTION FOR WORKING WITH MEMBERS WITH LEAD BASED PAINT.

- 17 THE EXISTING BRIDGE HAS BEEN POSTED FOR A LOAD LIMIT OF 6 TONS BASED ON THE CONDITION OF SOME OF THE EXISTING FLOOR BEAMS. THE CONTRACTOR SHALL VERIFY THE CONDITION OF FLOOR BEAMS THAT WILL BE LOADED BY THE CONSTRUCTION OPERATIONS AND DETERMINE THAT THE PROPOSED CONSTRUCTION LOADING DOES NOT EXCEED THE BEAM CAPACITIES.

- 18 THE CONTRACTOR SHALL NOT PLACE EQUIPMENT OR MATERIALS ON THE EXISTING BRIDGE IN A MANNER THAT COULD OVERLOAD THE EXISTING BRIDGE COMPONENTS (DECK, FLOOR BEAMS, GIRDERS, ETC) AND SHALL CONSIDER THE DETERIORATED CONDITION OF STRUCTURAL ELEMENTS AS NEEDED. IF THE CONTRACTOR'S WORK PLAN INVOLVES PLACEMENT OF EQUIPMENT ON THE BRIDGE, SUCH AS A SMALL CRANE OR OTHER EQUIPMENT TO FACILITATE COMPLETION OF THE WORK, THE CONTRACTOR SHALL PLAN HIS WORK IN ADVANCE AND SHALL PROVIDE LAYOUT DRAWINGS OF PROPOSED EQUIPMENT AND LOAD DISTRIBUTION METHODS WITH STRUCTURAL CALCULATIONS PREPARED UNDER THE SUPERVISION OF A REGISTERED PROFESSIONAL ENGINEER LICENSED IN THE STATE OF NEW HAMPSHIRE. THE PLAN AND CALCULATIONS SHALL BE SUBMITTED FOR REVIEW AND SHALL BE STAMPED BY THE CONTRACTOR'S PROFESSIONAL ENGINEER.

- 19 PAVEMENT JOINT ADHESIVE, ITEM 403.6 SHALL BE APPLIED TO ALL EXPOSED LONGITUDINAL JOINTS FOR ALL PAVEMENT COURSES PRIOR TO PLACEMENT OF EACH PAVEMENT COURSE PASS. PAVEMENT JOINT ADHESIVE SHALL ALSO BE APPLIED AT PAVEMENT MATCH TRANSVERSE JOINTS AND ALL PAVEMENT JOINTS ACROSS THE LENGTH OF BRIDGE DECK (FOR BOTH WEARING AND BASE COURSES). APPLICATION OF JOINT ADHESIVE SHALL ALSO BE PLACED ALONG BRIDGE CURBES AND U-BACK WINGWALL CURBS FOR ALL PAVEMENT COURSES.

REVISIONS AFTER PROPOSAL

DESCRIPTION

STATION

STATION

DATE

NUMBER

NOTEBOOKS

BOOK

PAGE

BOOK

PAGE

BOOK

PAGE

DATE 11/10

DATE 4/13

DATE 4/13

DATE

EXISTING DETAIL

ARM

PROPOSED DESIGN

DEM

SHEET CHECKED

TAT

AS BUILT DETAILS

FAY, SPOFFORD & THORNDIKE, LLC

CITY OF PORTSMOUTH			
DEPARTMENT OF PUBLIC WORKS			
INDEX OF SHEETS AND GENERAL NOTES			
FEDERAL PROJECT NO.	STATE PROJECT NO.	SHEET NO.	TOTAL SHEETS
X-A000(417)	14493	2	91

GENERAL

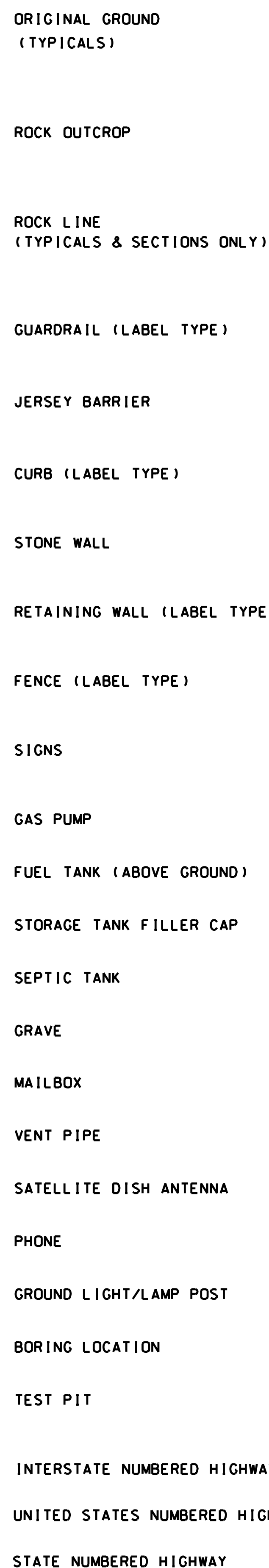
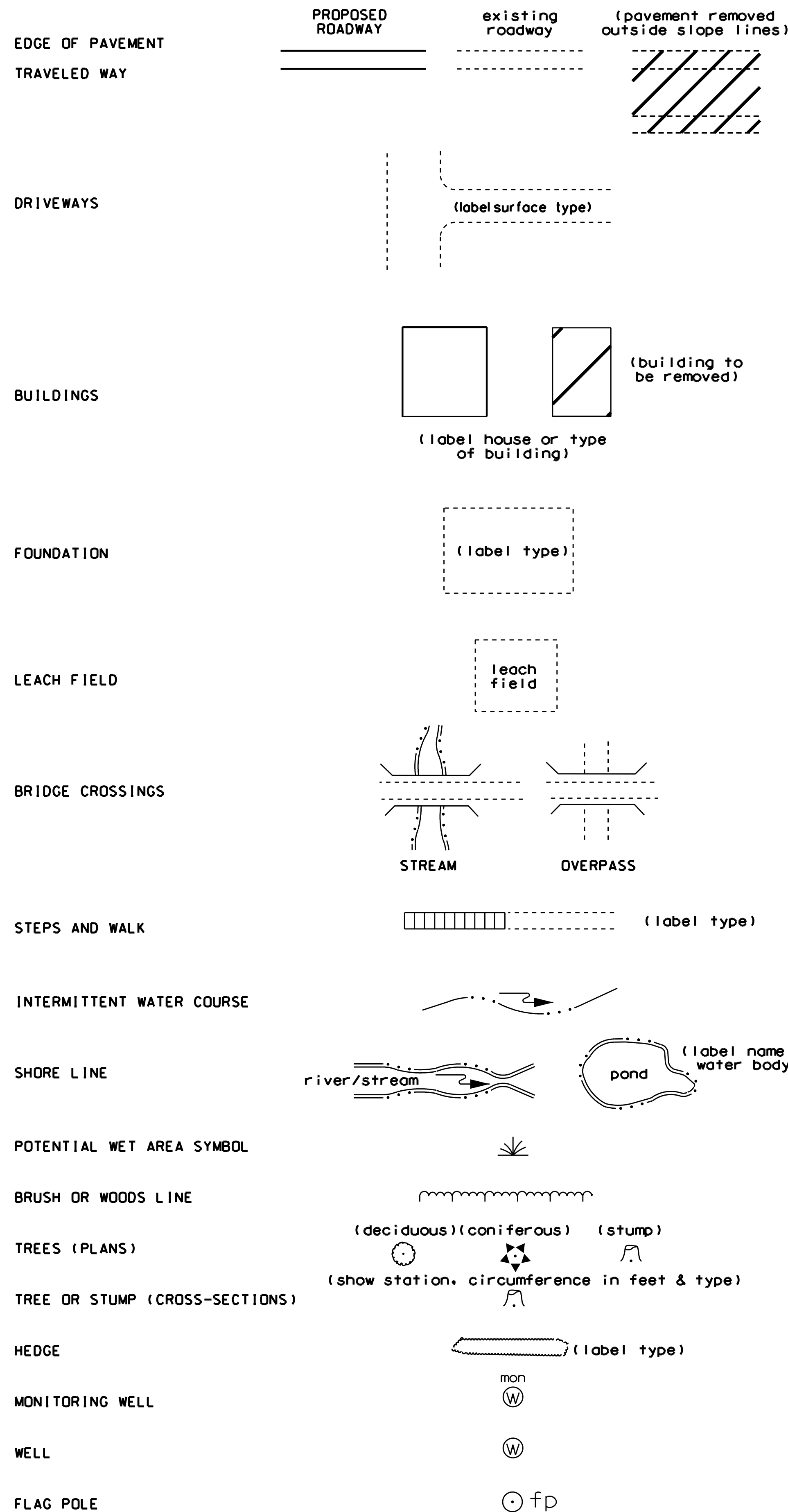

WETLANDS

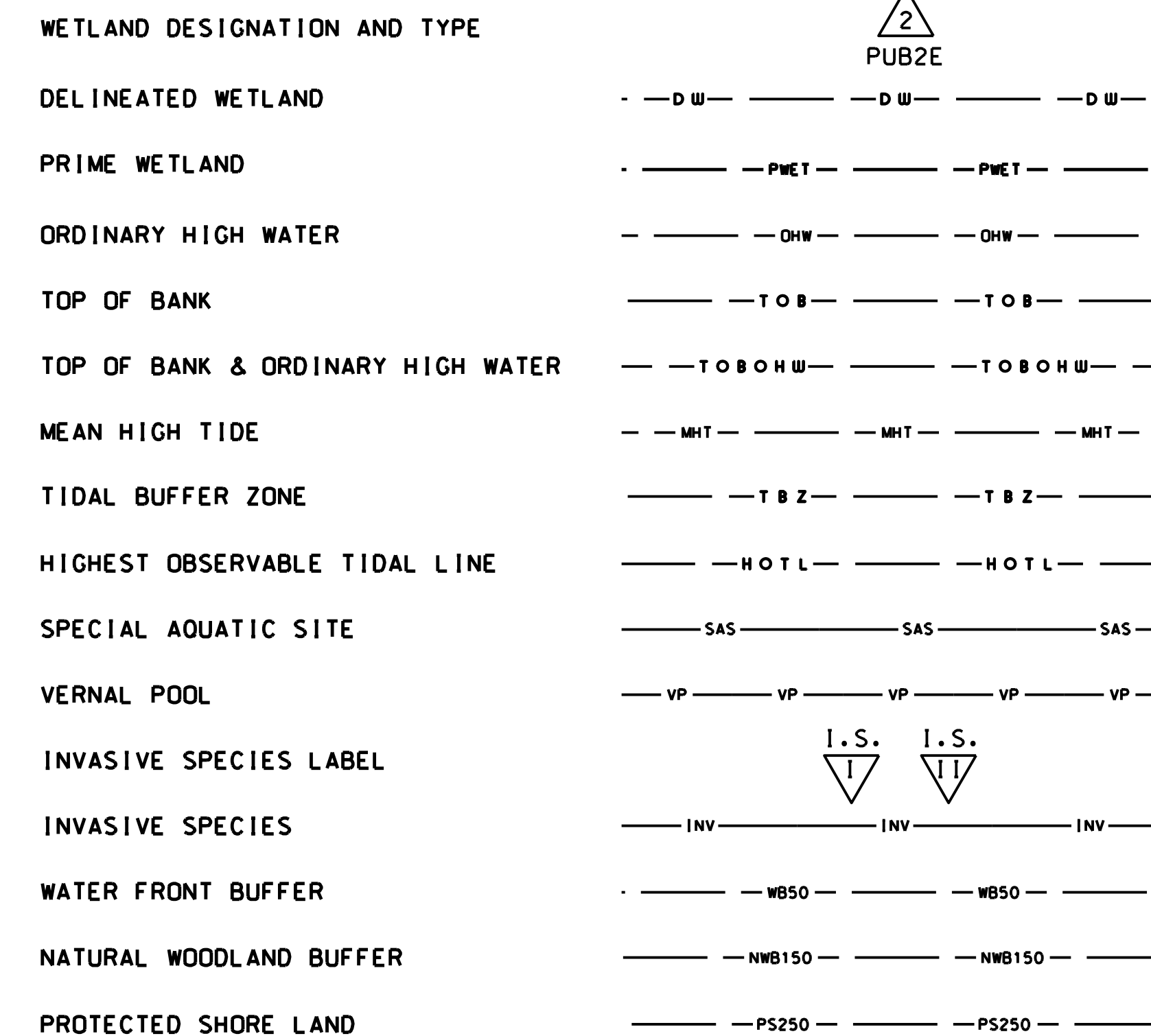

FLOODPLAIN / FLOODWAY

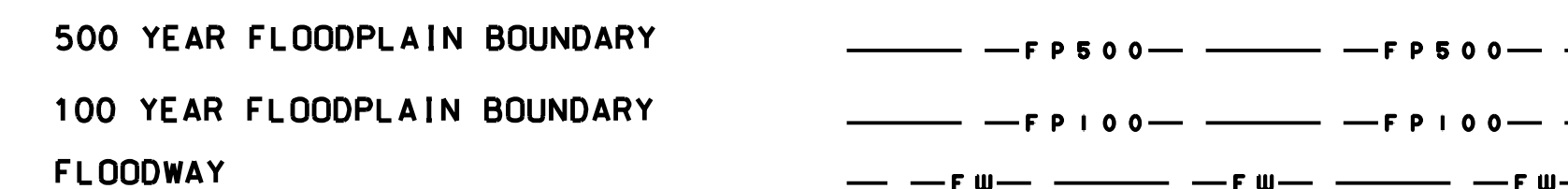

ENGINEERING

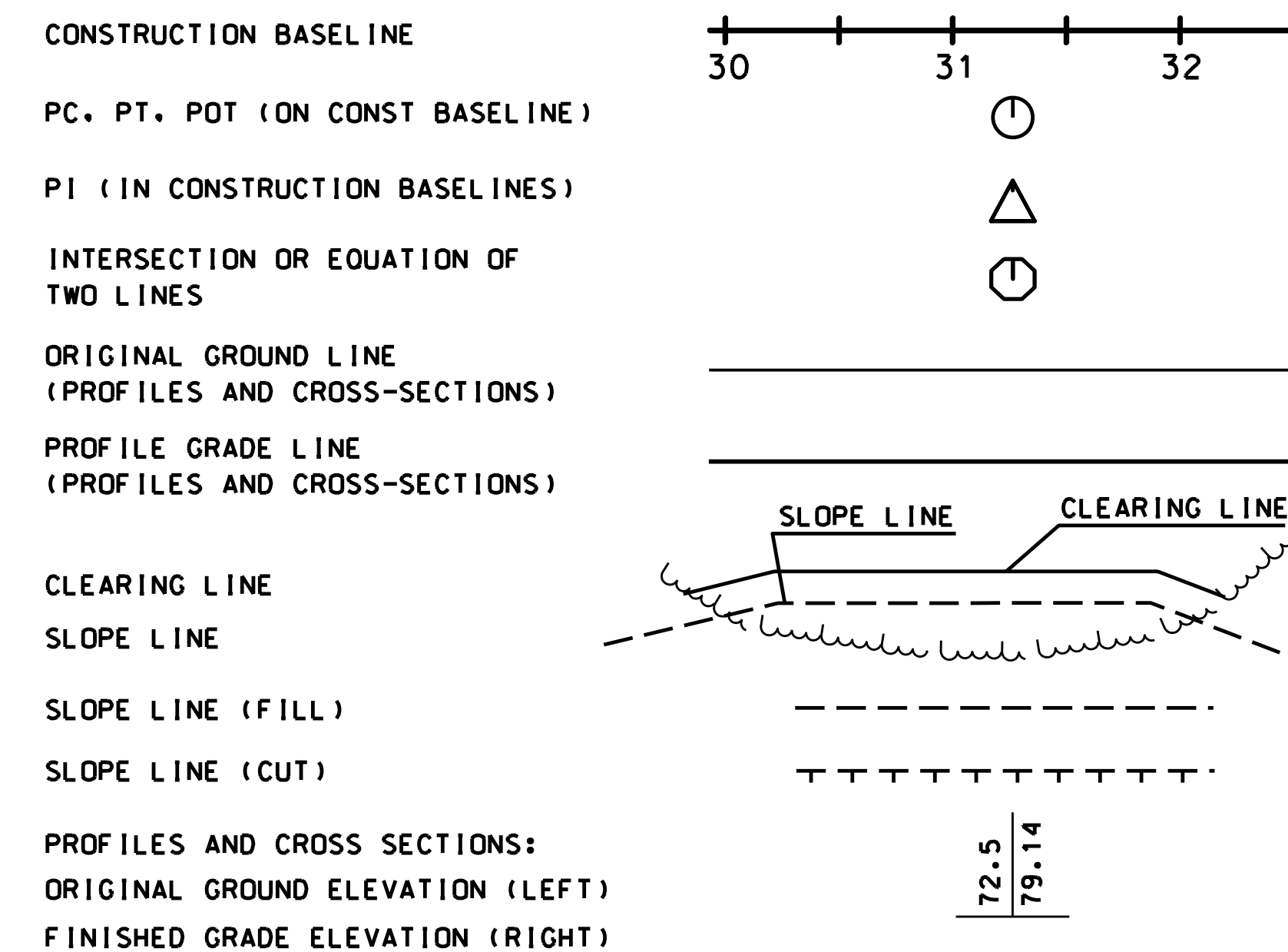

SHEET 1 OF 2

STATE OF NEW HAMPSHIRE
DEPARTMENT OF TRANSPORTATION • BUREAU OF HIGHWAY DESIGN
STANDARD SYMBOLS

FAY, SPOFFORD & THORNDIKE, LLC

REVISION DATE	DGN	STATE PROJECT NO.	SHEET NO.	TOTAL SHEETS
3-15-13	s+dsymb1	14493	3	91

DRAINAGE

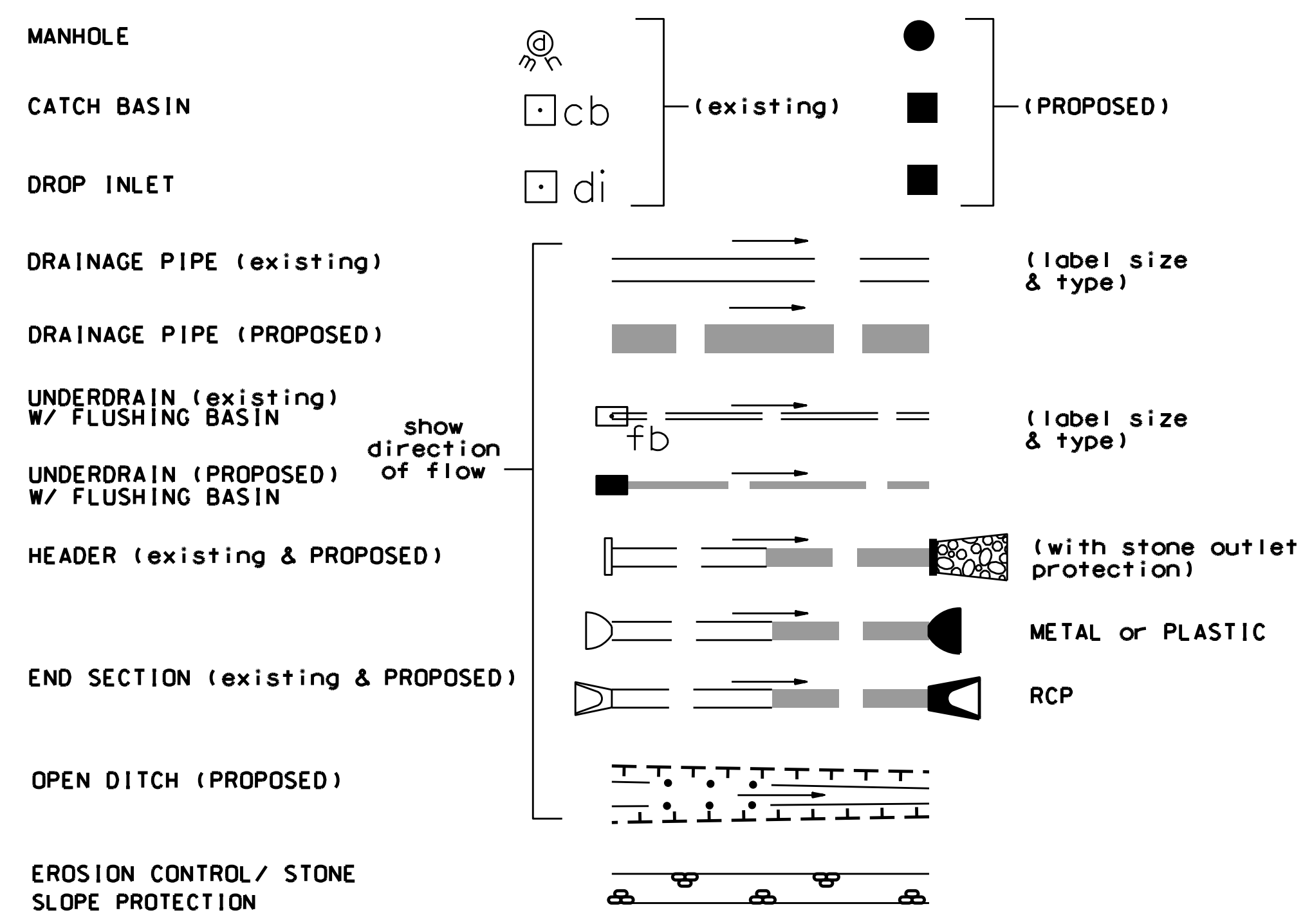

BOUNDARIES / RIGHT-OF-WAY

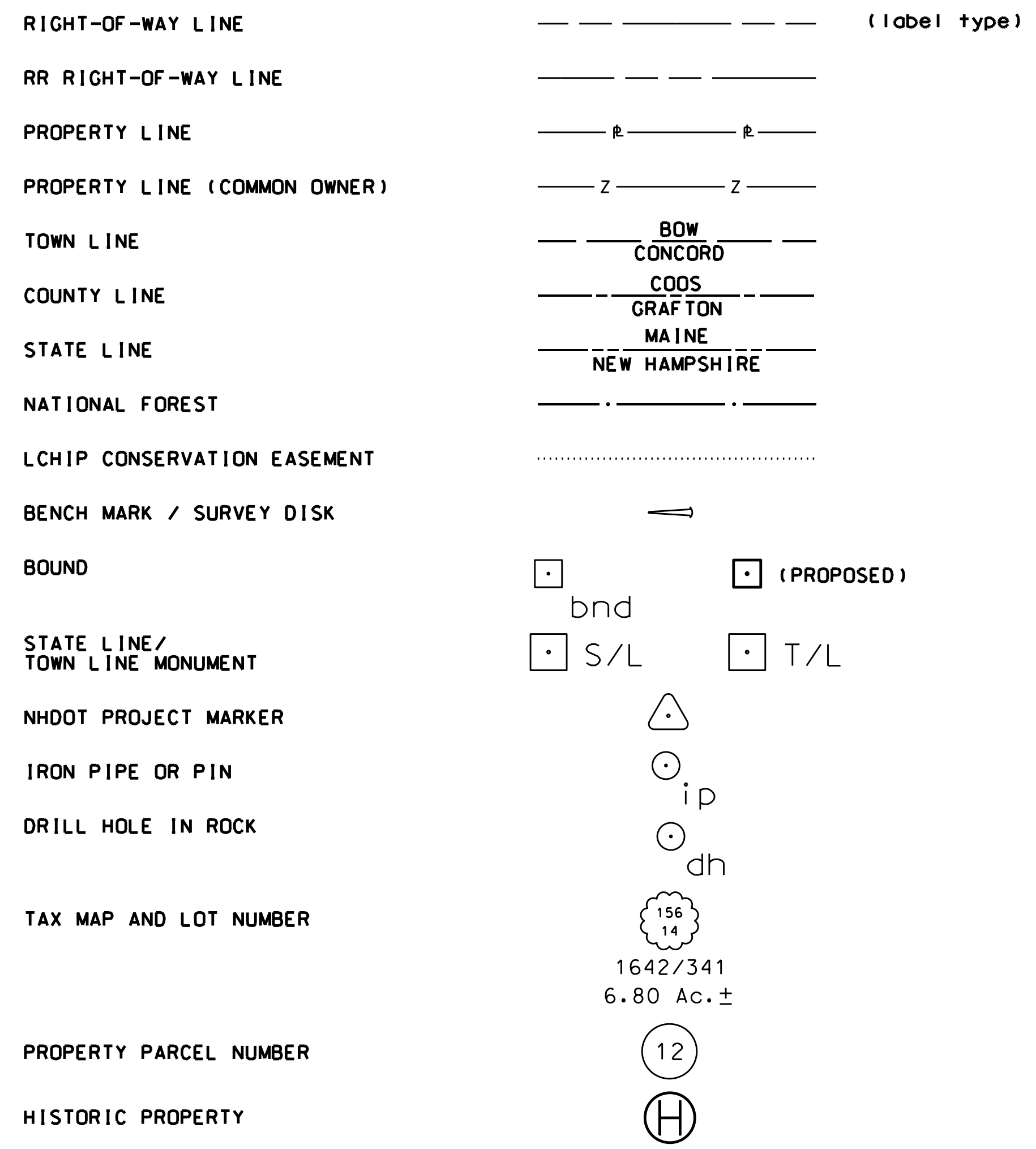

UTILITIES

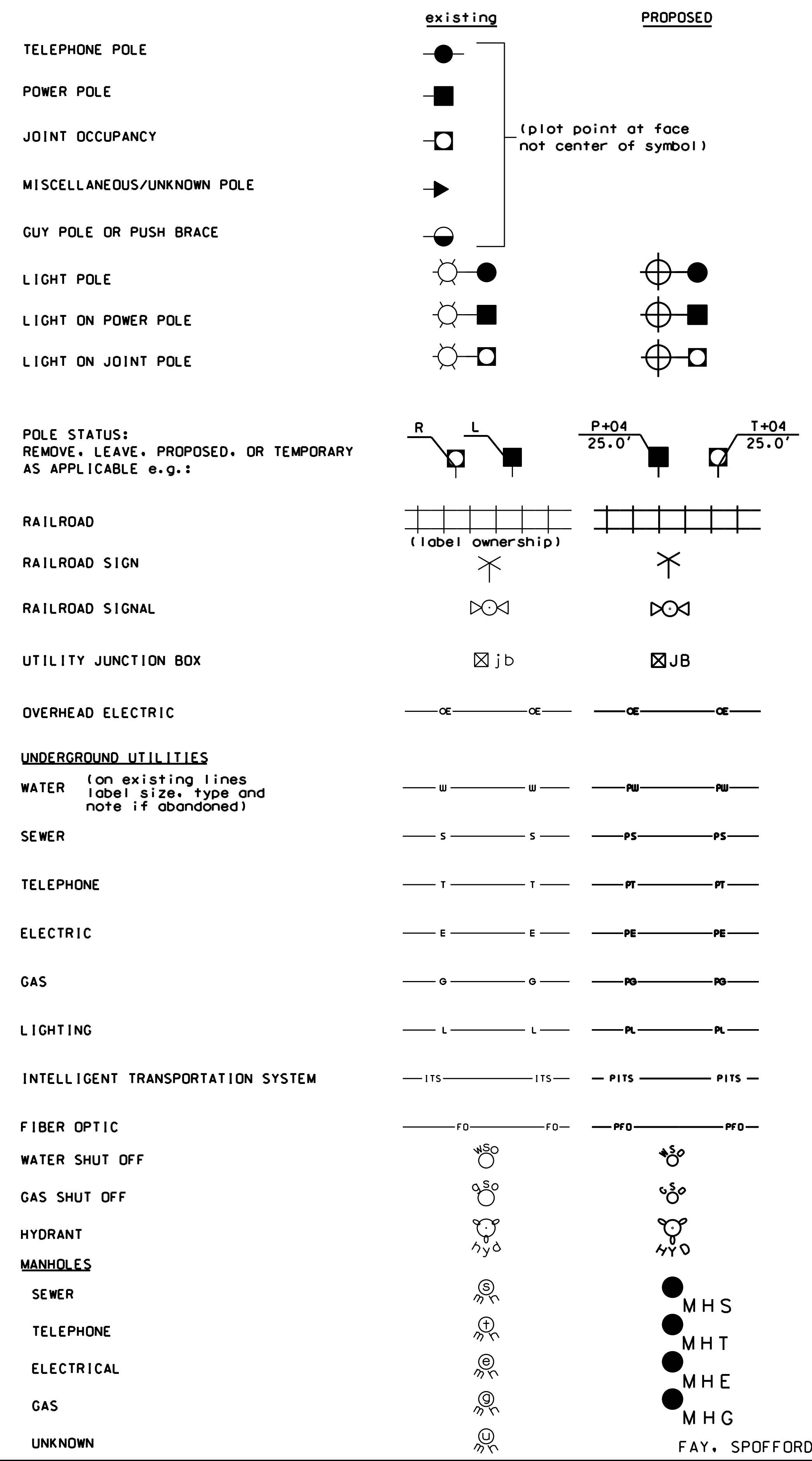

TRAFFIC SIGNALS / ITS

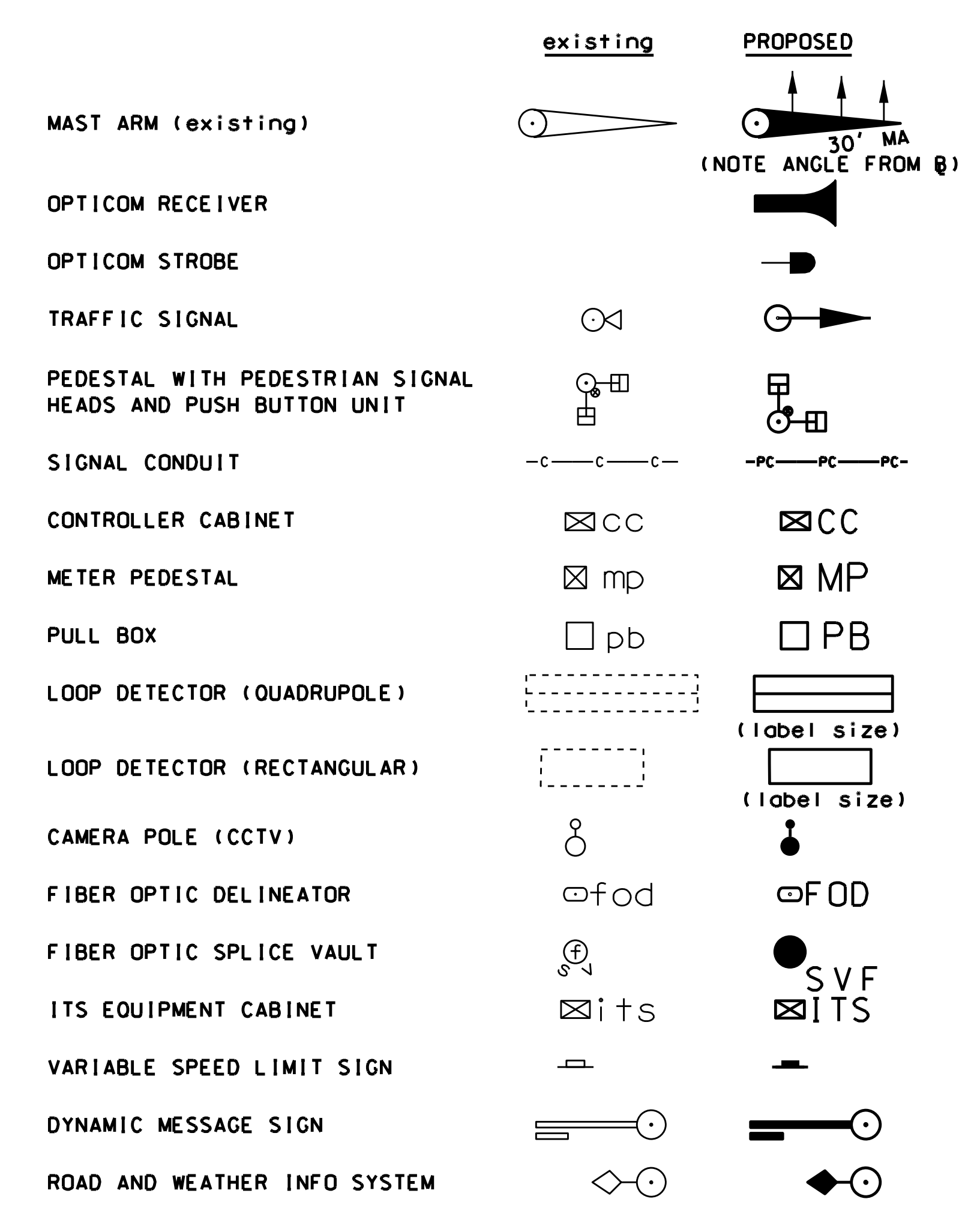

CONSTRUCTION NOTES

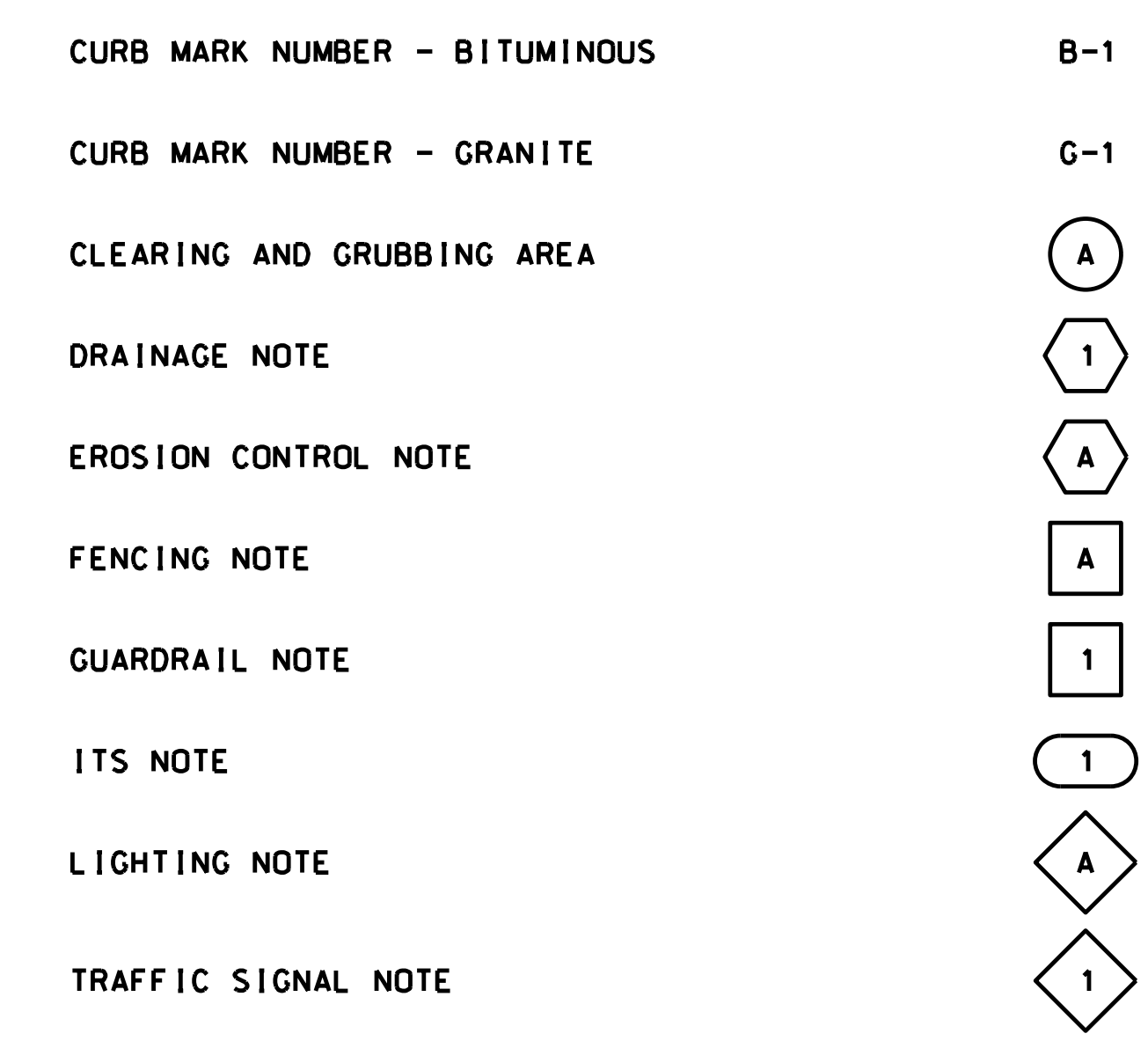

STATE OF NEW HAMPSHIRE				
DEPARTMENT OF TRANSPORTATION • BUREAU OF HIGHWAY DESIGN				
STANDARD SYMBOLS				
REVISION DATE	DGN	STATE PROJECT NO.	SHEET NO.	TOTAL SHEETS
3-15-13	s+dsymb2	14493	4	91

EXISTING DETAIL	ARM	DATE	11/10
	DEM	DATE	4/13
PROPOSED DESIGN	DEM	DATE	4/13
	TAT	DATE	4/13
SHEET CHECKED	TAT	DATE	
		DATE	
AS BUILT DETAILS		DATE	
		DATE	

REVISIONS AFTER PROPOSAL	STATION	DESCRIPTION
	NUMBER	DATE
NOTEBOOKS	BOOK	PAGE
	BOOK	PAGE
STATION	DATE	
	NUMBER	

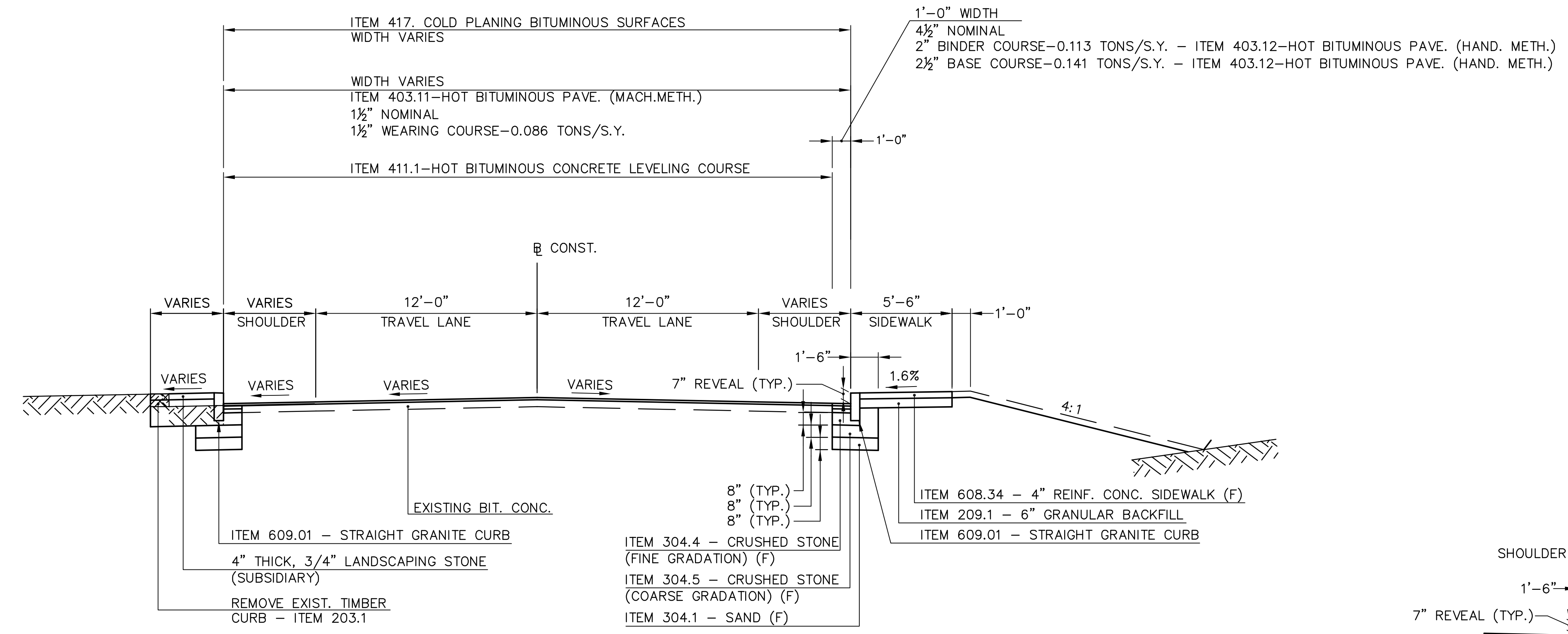

SAGAMORE AVE
 STA. 105+36± TO 106+50±
 SCALE: 1/4" = 1'-0"

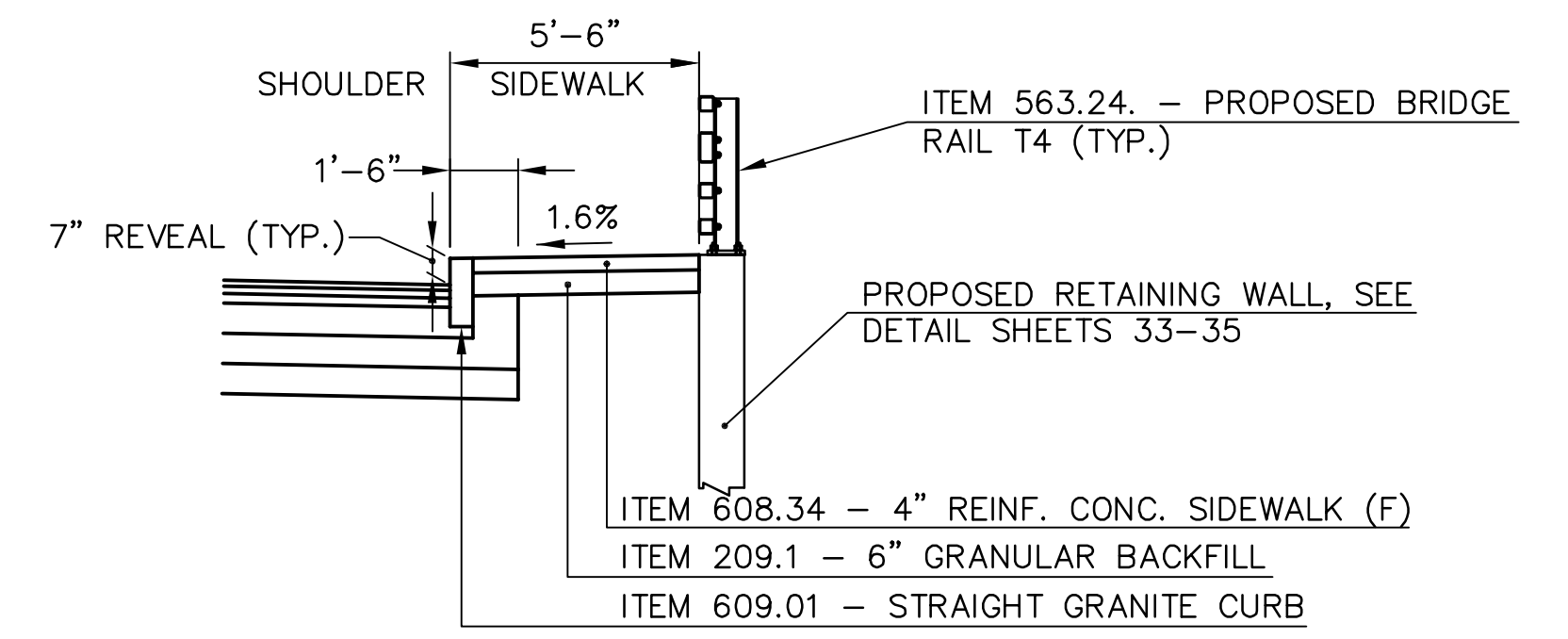

SAGAMORE AVE DETAIL
 STA. 108+10± TO 108+77±
 SCALE: 1/4" = 1'-0"

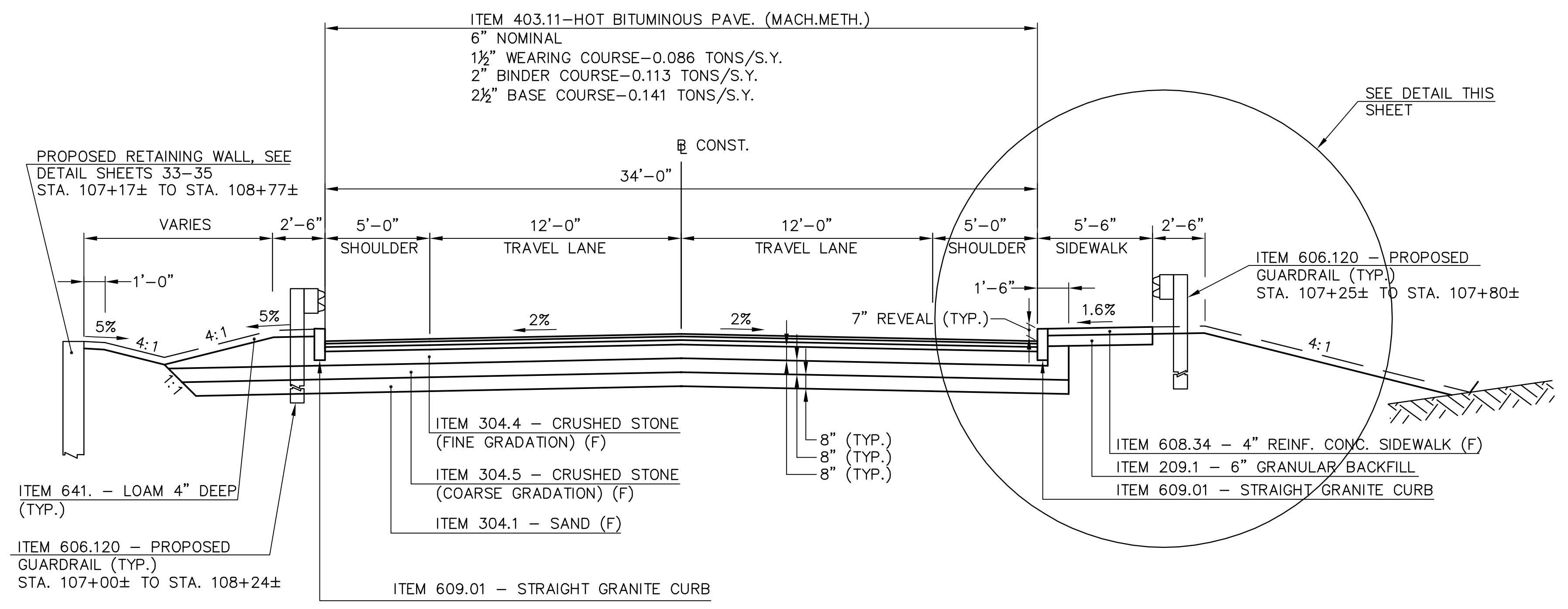

SAGAMORE AVE
 STA. 106+50± TO 108+77±
 SCALE: 1/4" = 1'-0"

SCALE: HORIZ. 1/4"=1 FT.

FAY, SPOFFORD & THORNDIKE, LLC

CITY OF PORTSMOUTH			
DEPARTMENT OF PUBLIC WORKS			
TYPICAL SECTION SAGAMORE AVENUE			
FEDERAL PROJECT NO.	STATE PROJECT NO.	SHEET NO.	TOTAL SHEETS
X-A000(417)	14493	5	91

EXISTING DETAIL	ARM	DATE	11/10
	DEM	DATE	4/13
PROPOSED DESIGN	DEM	DATE	4/13
	TAT	DATE	4/13
SHEET CHECKED	TAT	DATE	
		DATE	
AS BUILT DETAILS		DATE	
		DATE	

REVISIONS AFTER PROPOSAL	STATION	DESCRIPTION
	NUMBER	DATE
NOTEBOOKS	BOOK	PAGE
	BOOK	PAGE
STATION	DATE	

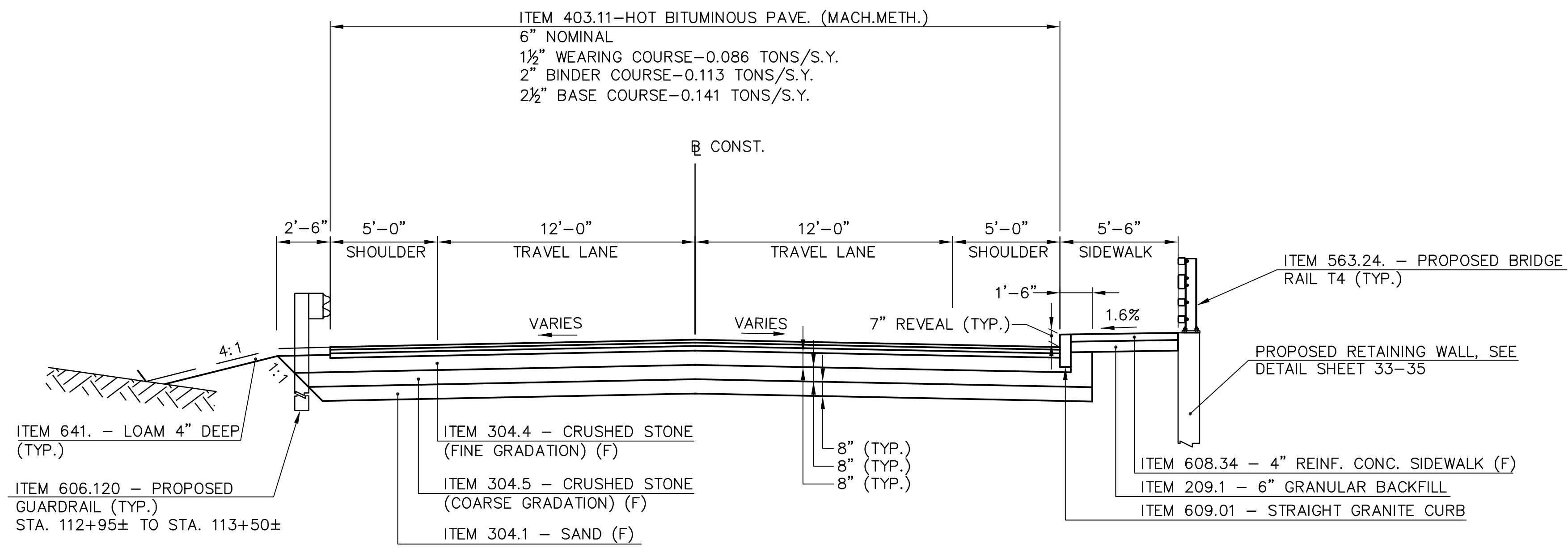

SAGAMORE AVE
 STA. 112+95± TO 115+50±
 SCALE: 1/4" = 1'-0"

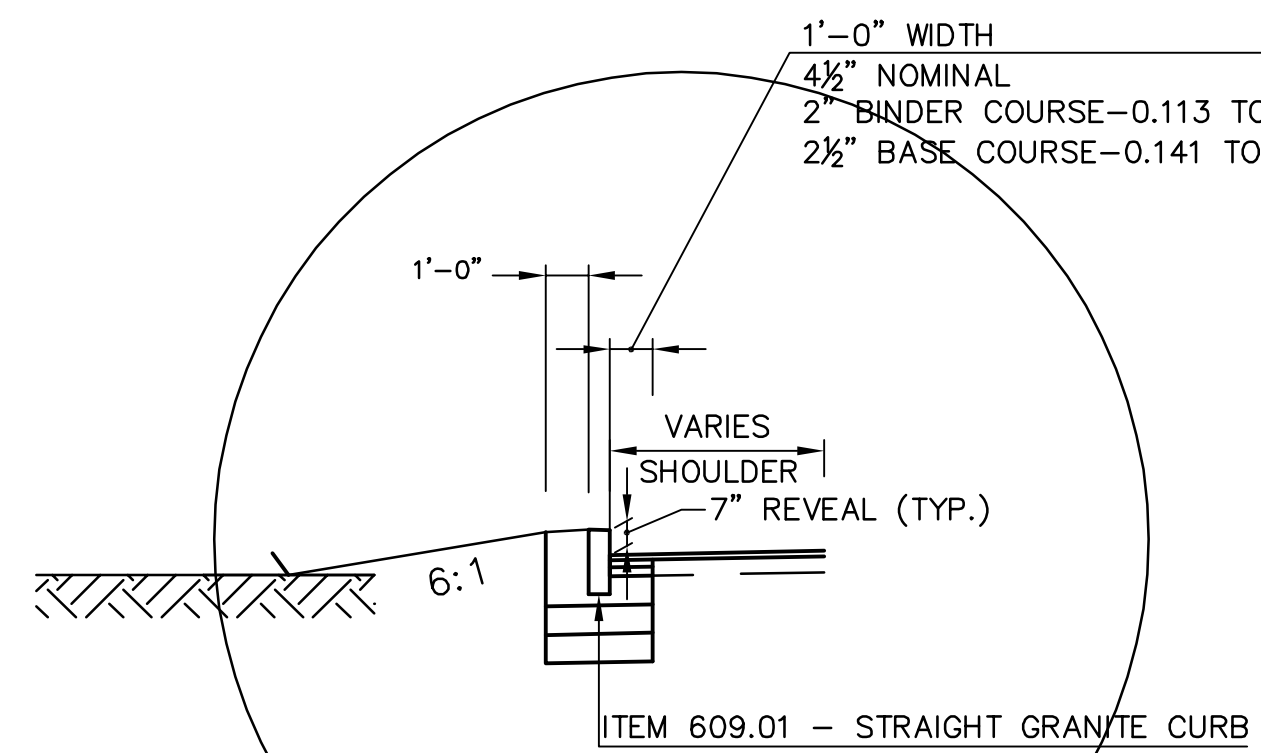

SAGAMORE AVE DETAIL
 STA. 116+41± TO 117+08±
 SCALE: 1/4" = 1'-0"

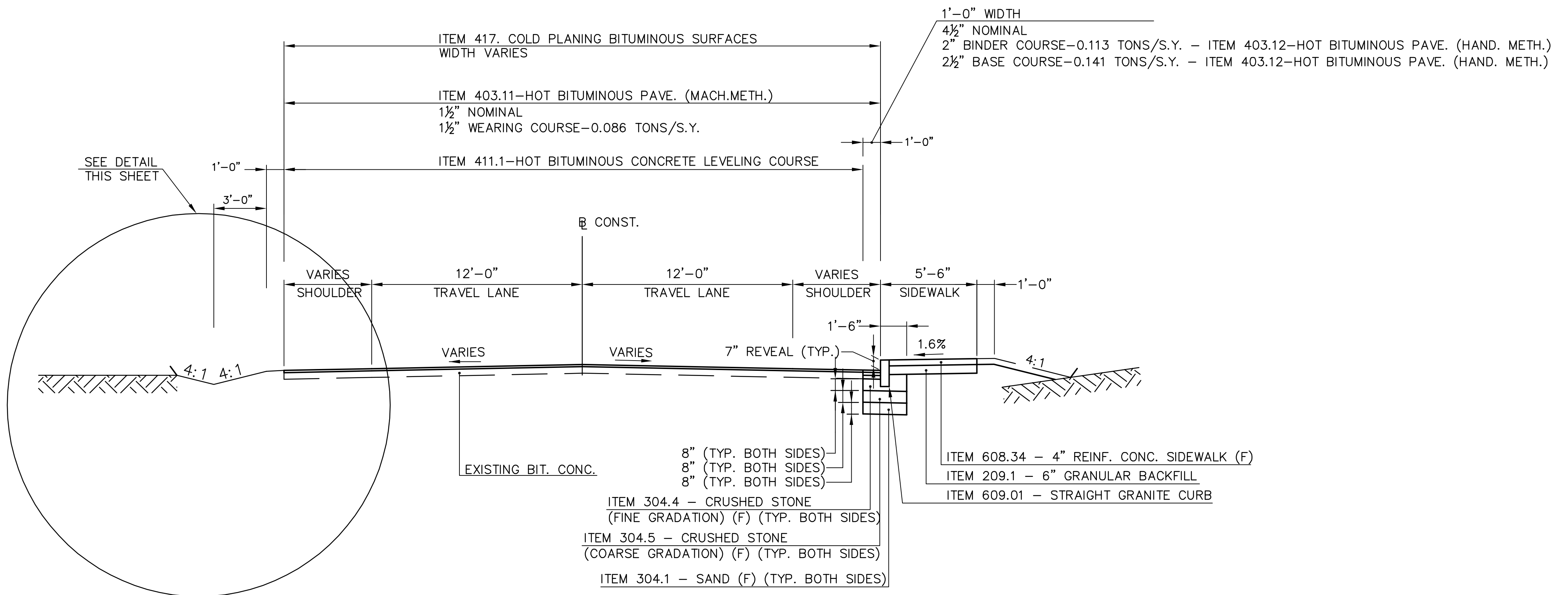

SAGAMORE AVE
 STA. 115+50± TO 118+93±
 SCALE: 1/4" = 1'-0"

SCALE: HORIZ. 1/4"=1 FT.

FAY, SPOFFORD & THORNDIKE, LLC

CITY OF PORTSMOUTH			
DEPARTMENT OF PUBLIC WORKS			
TYPICAL SECTION SAGAMORE AVENUE			
FEDERAL PROJECT NO.	STATE PROJECT NO.	SHEET NO.	TOTAL SHEETS
X-A000(417)	14493	6	91

EXISTING DETAIL	ARM	DATE	11/10
PROPOSED DESIGN	DEM	DATE	4/13
SHEET CHECKED	TAT	DATE	4/13
AS BUILT DETAILS		DATE	

NUMBER	DATE	STATION	STATION	DESCRIPTION

NOTEBOOKS	PAGE
BOOK	PAGE
BOOK	PAGE
BOOK	PAGE

CURBING					
ITEM NO.			202.6	609.01	609.02
DESCRIPTION	MARK NUMBER	RADIUS	CURB REMOVAL FOR STORAGE	STRAIGHT GRANITE CURB	CURVED GRANITE CURB
UNIT		LF	LF	LF	LF
LOCATION					
START	END				
STA. 105+38.42, 22.50' RT.	STA. 105+47.49, 17.00' RT.	G1	10.1		11.1
STA. 105+47.49, 17.00' RT.	STA. 105+72.55, 17.00' RT.	G2	1983.0	24.9	
STA. 105+72.55, 17.00' RT.	STA. 105+81.59, 22.50' RT.	G3	10.0		11.1
STA. 106+86.01, 22.50' RT.	STA. 106+91.76, 18.70' RT.	G4		6.8	
STA. 106+91.76, 18.70' RT.	STA. 106+97.40, 17.00' RT.	G5	10.0		5.9
STA. 106+97.40, 17.00' RT.	STA. 108+21.22, 17.00' RT.	G6	1983.0	122.8	
STA. 108+21.22, 17.00' RT.	STA. 108+76.75, 17.00' RT.	G7		55.5	
STA. 108+21.22, 17.00' LT.	STA. 108+76.75, 17.00' LT.	G8		55.5	
STA. 112+94.75, 17.00' RT.	STA. 113+87.65, 17.00' RT.	G9		92.9	
STA. 113+87.65, 17.00' RT.	STA. 114+42.55, 17.00' RT.	G10	403.0	52.7	
STA. 114+42.55, 17.00' RT.	STA. 114+52.04, 22.50' RT.	G11	10.0		11.2
STA. 114+70.68, 34.58' LT.	STA. 114+71.28, 38.02' LT.	G12		3.5	
STA. 115+11.41, 27.43' RT.	STA. 115+14.77, 38.80' RT.	G13		11.8	
STA. 115+11.41, 27.43' RT.	STA. 115+18.54, 24.28' RT.	G14	3.8		10.5
STA. 115+18.54, 24.28' RT.	STA. 115+25.98, 33.79' RT.	G15		11.8	
STA. 115+49.34, 22.50' RT.	STA. 115+58.27, 17.00' RT.	G16	10.0		11.0
STA. 115+58.27, 17.00' RT.	STA. 117+58.92, 17.00' RT.	G17		200.7	
STA. 117+58.92, 17.00' RT.	STA. 117+64.94, 19.01' RT.	G18	10.0		6.5
STA. 117+64.94, 19.01' RT.	STA. 117+69.57, 22.50' RT.	G19		5.8	
STA. 118+03.85, 22.50' RT.	STA. 118+06.55, 18.97' RT.	G20		4.5	
STA. 118+10.52, 17.00' RT.	STA. 118+72.07, 17.00' RT.	G21		61.6	
STA. 118+72.07, 17.00' RT.	STA. 118+85.84, 22.50' RT.	G22	20.0	15.2	
STA. 112+94.75, 17.00' RT.	STA. 113+48.63, 17.00' LT.	G23		53.9	
STA. 118+06.55, 18.97' RT.	STA. 118+10.52, 17.00' RT.	G24	5.0		4.6
STA. 113+95.44, 24.56' LT.	STA. 113+97.35, 21.50' LT.	G25		3.8	
STA. 113+95.44, 21.40' LT.	STA. 114+05.25, 17.00' LT.	G26	10.0		9.7
STA. 114+05.25, 17.00' LT.	STA. 114+25.66, 17.00' LT.	G27	437.0	21.2	
STA. 114+25.66, 17.00' LT.	STA. 114+42.59, 28.84' LT.	G28	20.0	22.6	
STA. 114+42.59, 28.84' LT.	STA. 114+48.08, 43.19' LT.	G29		15.5	
STA. 114+70.68, 34.58' LT.	STA. 114+84.37, 17.00' LT.	G30	15.0		25.9
STA. 114+84.37, 17.00' LT.	STA. 114+87.79, 17.00' LT.	G31	437.0	3.6	
STA. 114+87.79, 17.00' LT.	STA. 114+92.53, 22.30' LT.	G32	5.0		8.1
STA. 114+92.53, 22.30' LT.	STA. 114+91.77, 34.68' LT.	G33		12.4	
STA. 116+21.61, 30.75' LT.	STA. 116+40.61, 17.00' LT.	G34	20.0	25.1	
STA. 116+40.61, 17.00' LT.	STA. 117+08.06, 17.00' LT.	G35		67.5	
STA. 113+48.63, 17.00' LT.	STA. 113+51.10, 26.35' LT.	G36	5.0		13.1
STA. 113+51.10, 26.35' LT.	STA. 113+49.68, 27.16' LT.	G37		1.64	
STA. 105+38.42, 22.50' RT.	STA. 105+81.59, 22.50' RT.	G38	1977.5	42.68	
STA. 105+36.39, 20.50' LT.	STA. 106+53.72, 20.50' LT.	G39	2020.5	118.53	
STA. 106+53.72, 20.50' LT.	STA. 106+73.31, 39.68' LT.	G40	20.0	30.5	
STA. 106+73.31, 39.68' LT.	STA. 106+73.76, 52.57' LT.	G41		12.89	
STA. 106+93.06, 42.30' LT.	STA. 107+17.58, 17.00' LT.	G42	25.0	39.41	
STA. 107+17.58, 17.00' LT.	STA. 108+76.75, 17.00' LT.	G43	2017.0	104.53	
CURB REMOVAL FOR STORAGE				121.0	
SUBTOTAL				121.0	1301.5
ROUNDING				4	8.5
TOTAL				125.0	1310.0

SURFACING MATERIALS									
ITEM NO.	304.1	304.4	304.5	403.11	403.12	403.6	411.1	417	628.2
ITEM	SAND (F)	CRUSHED STONE (FINE GRADATION) (F)	CRUSHED STONE (COURSE GRADATION) (F)	HOT BITUMINOUS PAVEMENT, MACH. METH.	HOT BIT. PAVEMENT, HAND METHOD	PAVEMENT JOINT ADHESIVE	HOT BITUMINOUS CONCRETE LEVELING COURSE	COLD PLANING BITUMINOUS SURFACES	SAWED BITUMINOUS PAVEMENT
UNIT	CY	CY	CY	TON	TON	LF	TON	SY	LF
LOCATION									
SAGAMORE AVE.									
	523	675	523	964	177	6459	103	1826	727
SUBTOTAL									
	523	675	523	964	177	6459	103	1826	727
ROUNDING									
	0	0	0	6	3	41	7	24	23
TOTAL									
	523	675	523	970	180	6500	110	1850	750

INCIDENTAL ITEMS - PARTICIPATING			
ITEM NO.	ITEM	UNIT	TOTAL
201.881	INVASIVE SPECIES CONTROL, TYPE I	SY	560
201.882	INVASIVE SPECIES CONTROL, TYPE II	SY	140
206.19	COMMON STRUCTURE EXCAVATION, EXPLORATORY	CY	10
214.	FINE GRADING	U	1
611.90001	ADJUSTING WATER GATES AND SHUTOFFS SET BY OTHERS	EA	3
618.6	UNIFORMED OFFICERS	\$	*
618.7	FLAGGERS	HR	2000
619.1	MAINTENANCE OF TRAFFIC	U	1
619.25	PORTABLE CHANGEABLE MESSAGE SIGN	U	2
645.7	STORMWATER POLLUTION PREVENTION PLAN	U	1
645.71	MONITORING SWPPP & EROSION AND SEDIMENT CONTROLS	HR	260
670.6051	PEA STONE	CY	2
670.641	SAND FILTER MEDIA MIX	CY	8
670.9	TEMPORARY STABILIZATION OF UTILITY INFRASTRUCTURE	U	1
692.	MOBILIZATION	\$	*
693.	ON THE JOB TRAINING OF UNSKILLED WORKERS	\$	*
697.11	INVASIVE SPECIES CONTROL AND MANAGEMENT PLAN	U	1
697.41	CRITICAL PATH METHOD (CPM) ELECTRONIC SCHEDULE	U	1
698.12	FIELD OFFICE TYPE B	MO	24
698.2	PHYSICAL TESTING LABORATORY	MO	21
699.	MISCELLANEOUS TEMPORARY EROSION AND SEDIMENT CONTROL	\$	*
1008.8	WINTER MAINTENANCE	\$	*
1010.15	FUEL ADJUSTMENT	\$	*
1010.2	ASPHALT CEMENT ADJUSTMENT	\$	*

* - NOT A BID ITEM

TEMPORARY EROSION CONTROL					
ITEM NO.	645.0001	645.3	645.42	645.512	645.531
ITEM	TURBIDITY CURTAIN	EROSION STONE	TEMPORARY SLOPE STABILIZATION, TYPE B (WILDLIFE FRIENDLY)	COMPOST SOCK FOR PERIMETER BERM	SILT FENCE
UNIT	LF	TON	SY	LF	LF
LOCATION					
SAGAMORE AVE.					
		326	1591		
ALONG TOE OF SLOPE					
	950			600	1500
SUBTOTAL					
	950	326	1,591	600	1,500
ROUNDING					
	50	4	9	0	0
TOTAL					
	1,000	330	1,600	600	1,500

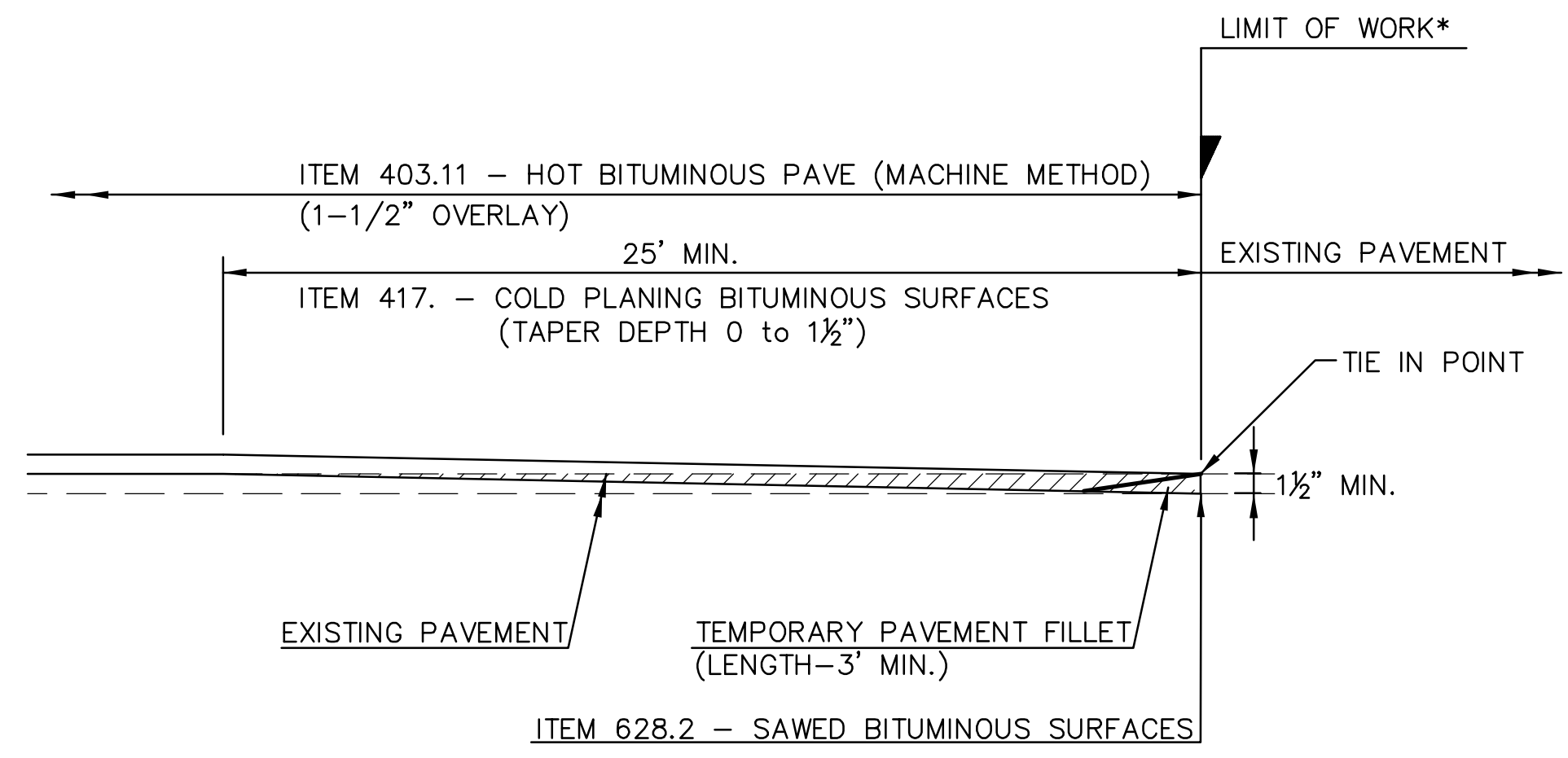

*APPLY AT LIMIT OF SAGAMORE GROVE

OVERLAY PAVEMENT TRANSITION DETAIL
NOT TO SCALE

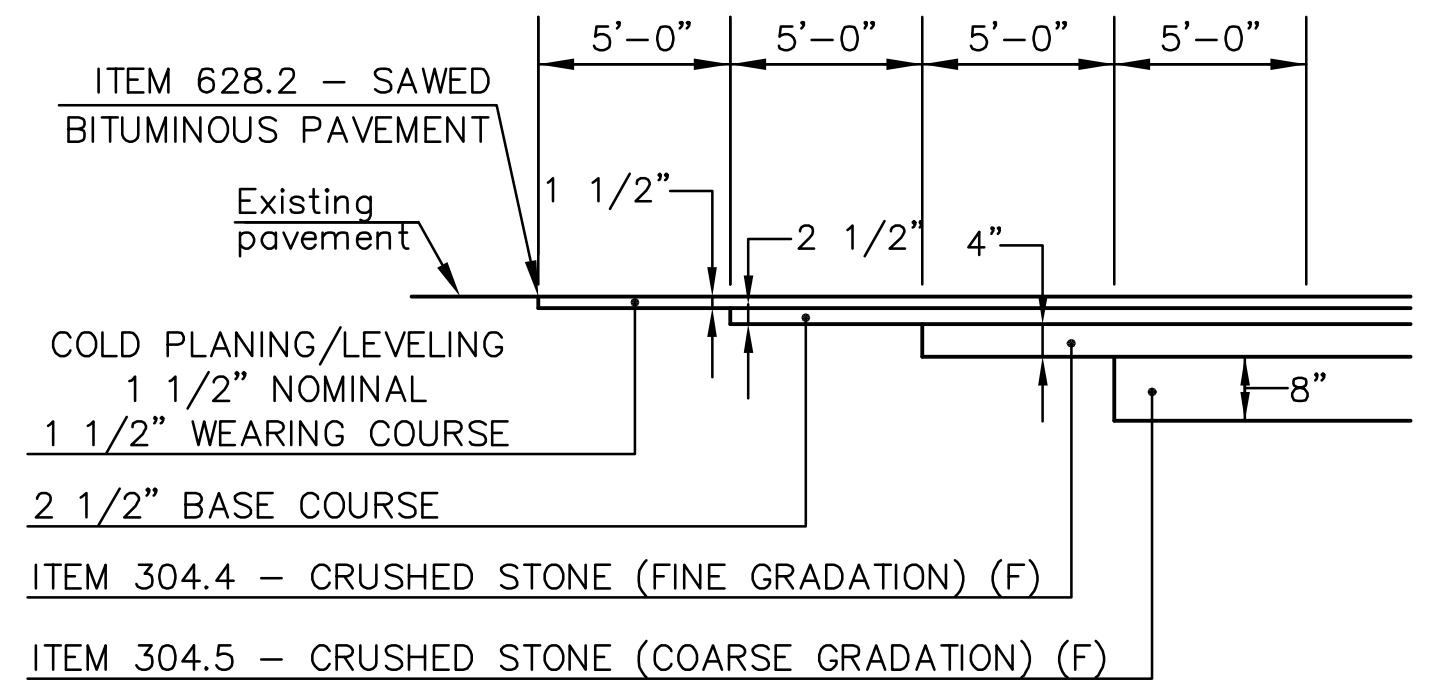

SHAW ROAD CONSTRUCTION APPROACH
NOT TO SCALE

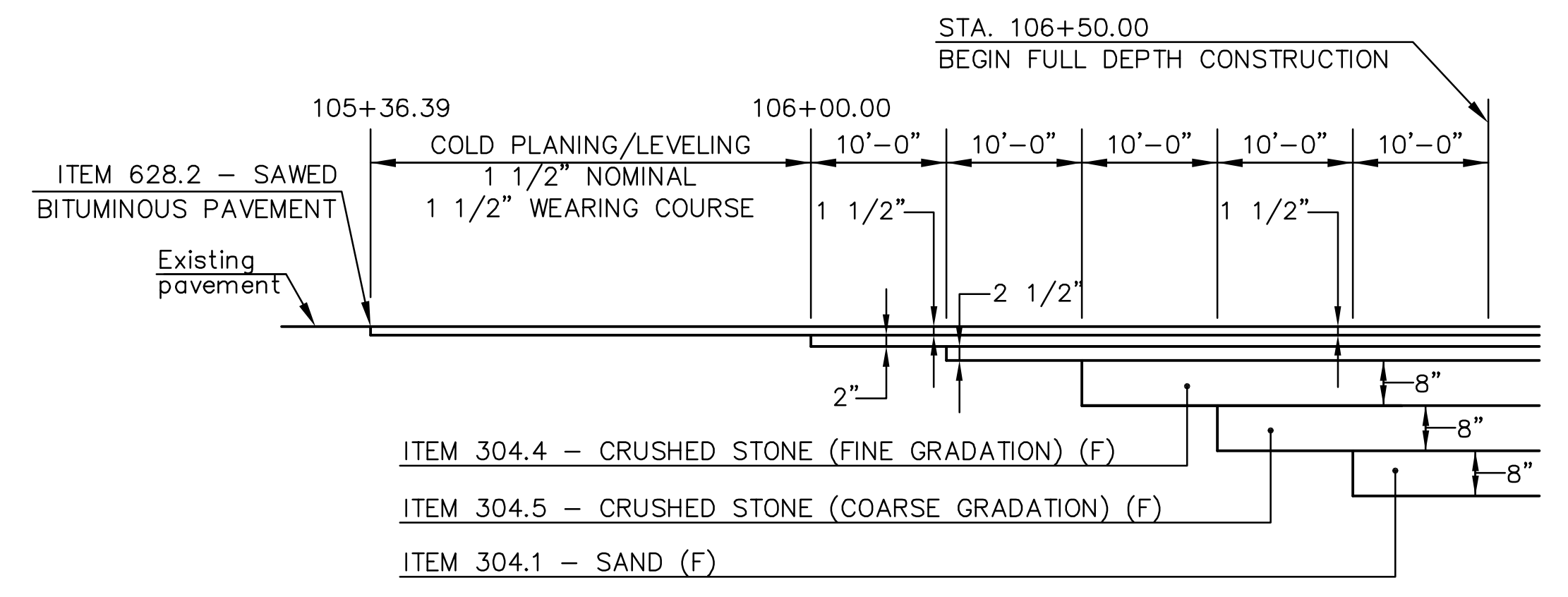

SAGAMORE AVE CONSTRUCTION APPROACH
STA. 105+36.39 TO STA. 106+50.00
NOT TO SCALE

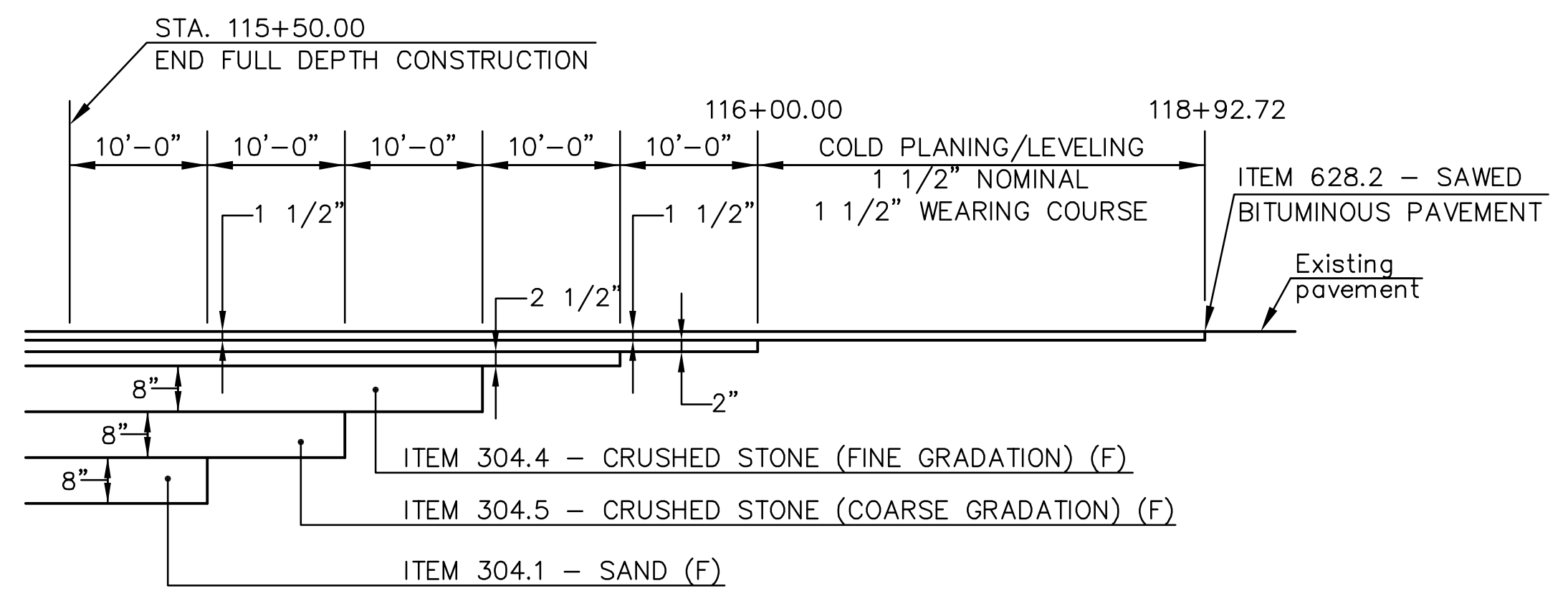

SAGAMORE AVE CONSTRUCTION APPROACH
STA. 115+50.00 TO STA. 118+92.72
NOT TO SCALE

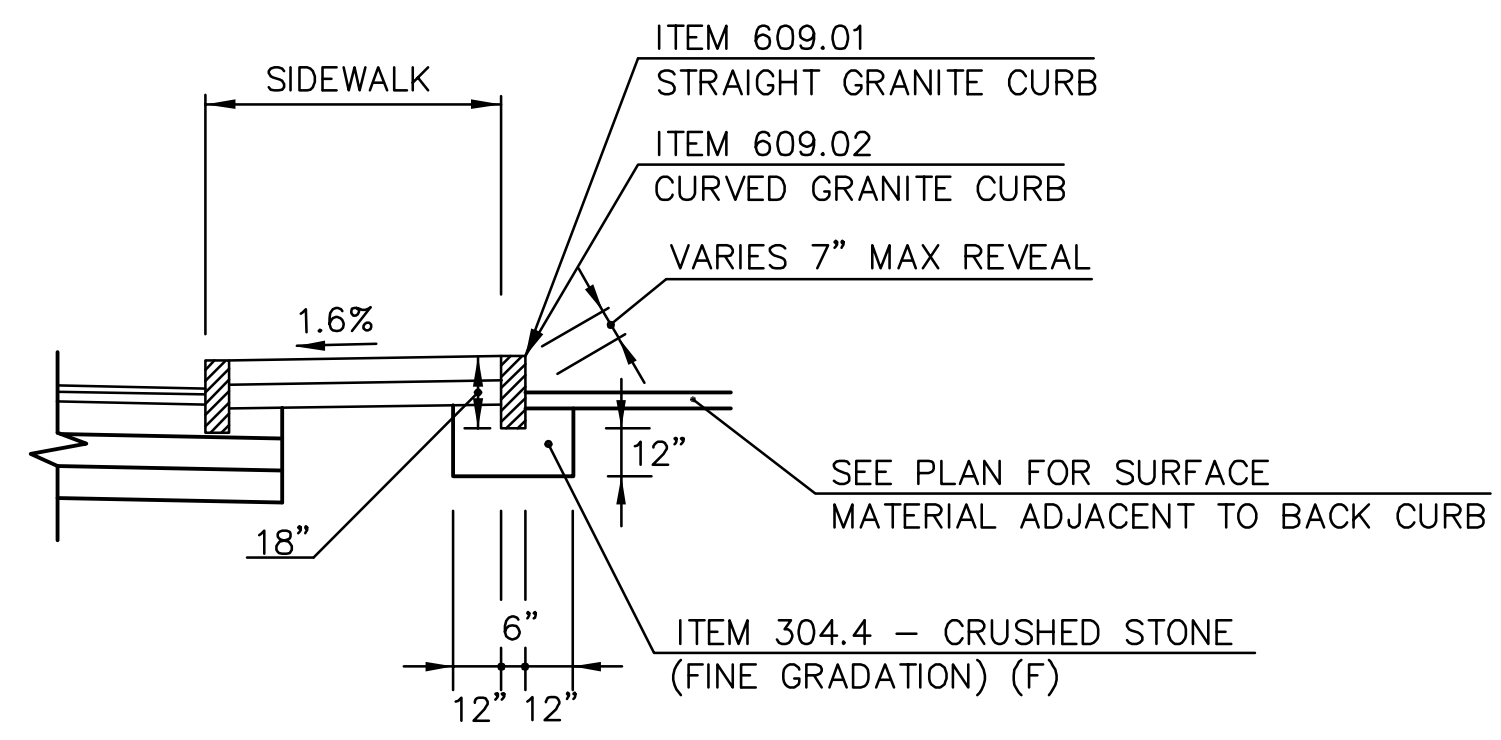

BACK-CURB DETAILS
NOT TO SCALE

NOT TO SCALE
(Except as noted)

FAY, SPOFFORD & THORNDIKE, LLC

CITY OF PORTSMOUTH			
DEPARTMENT OF PUBLIC WORKS			
MISCELLANEOUS DETAILS			
FEDERAL PROJECT NO.	STATE PROJECT NO.	SHEET NO.	TOTAL SHEETS
X-A000(417)	14493	10	91

EXISTING DETAIL	ARM	DATE	11/10
	PROPOSED DESIGN	DEM	DATE
SHEET CHECKED	TAT	DATE	4/13
	AS BUILT DETAILS	DATE	
REVISIONS AFTER PROPOSAL	NUMBER	DATE	
	STATION		
	DESCRIPTION		
NOTEBOOKS	BOOK	PAGE	
	BOOK	PAGE	
	BOOK	PAGE	

EXISTING DETAIL	ARM	DATE	11/10
	PROPOSED DESIGN	DEM	DATE
SHEET CHECKED	TAT	DATE	4/13
	AS BUILT DETAILS	DATE	
NOTEBOOKS	BOOK	PAGE	
	BOOK	PAGE	
	BOOK	PAGE	
REVISIONS AFTER PROPOSAL	NUMBER	DATE	
	STATION		
	DESCRIPTION		

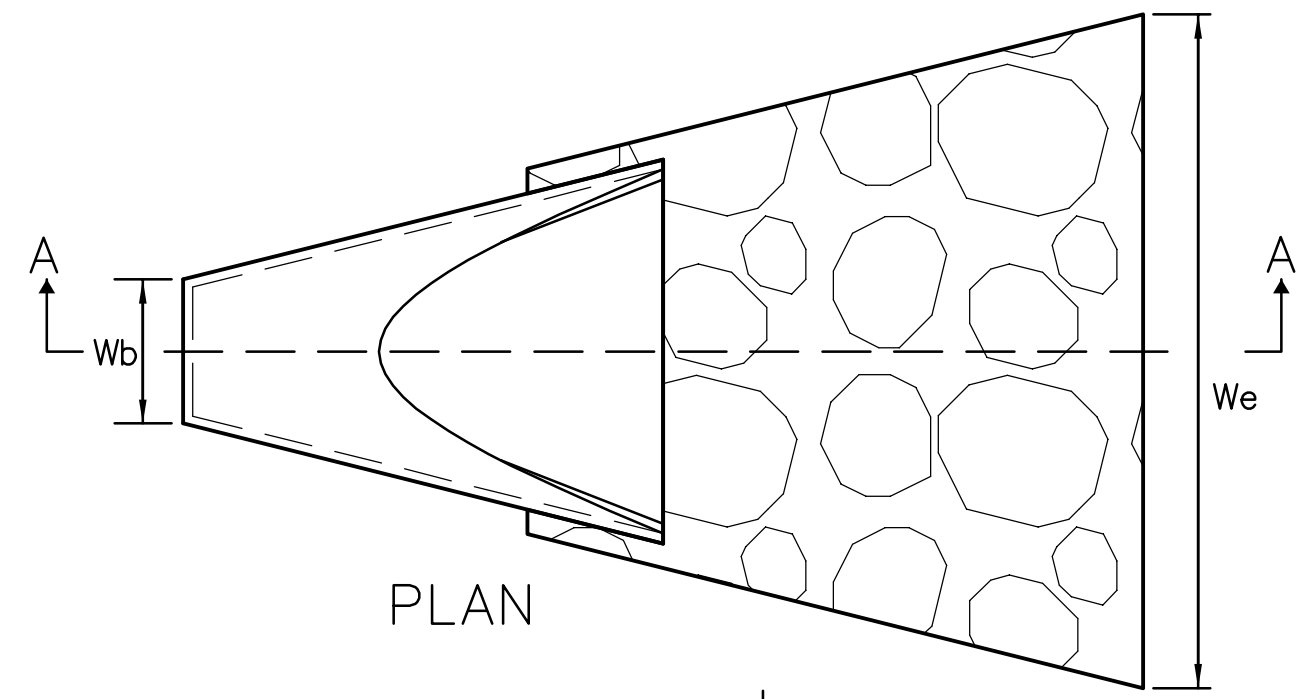

PLAN

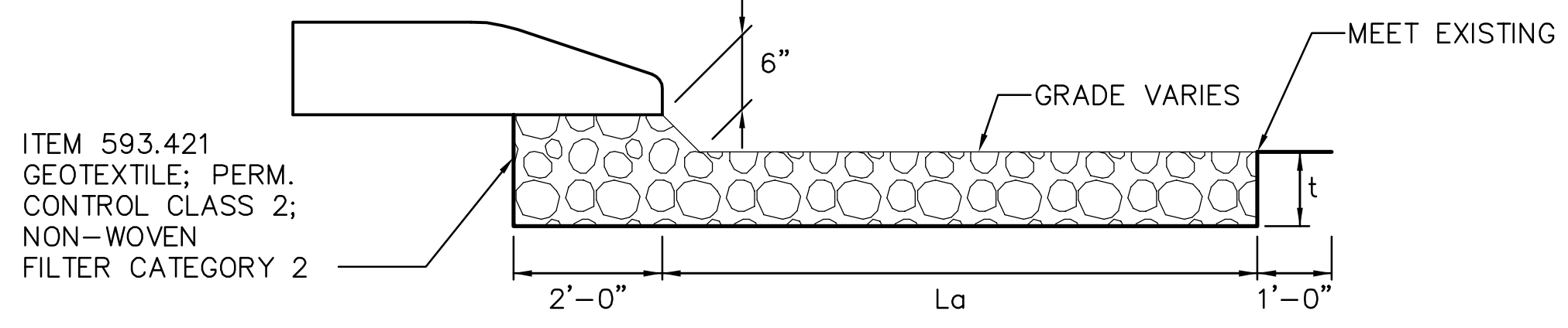

SECTION A-A

PIPE OUTLET TO FLAT AREA WITH NO CHANNEL

SCALE: NOT TO SCALE

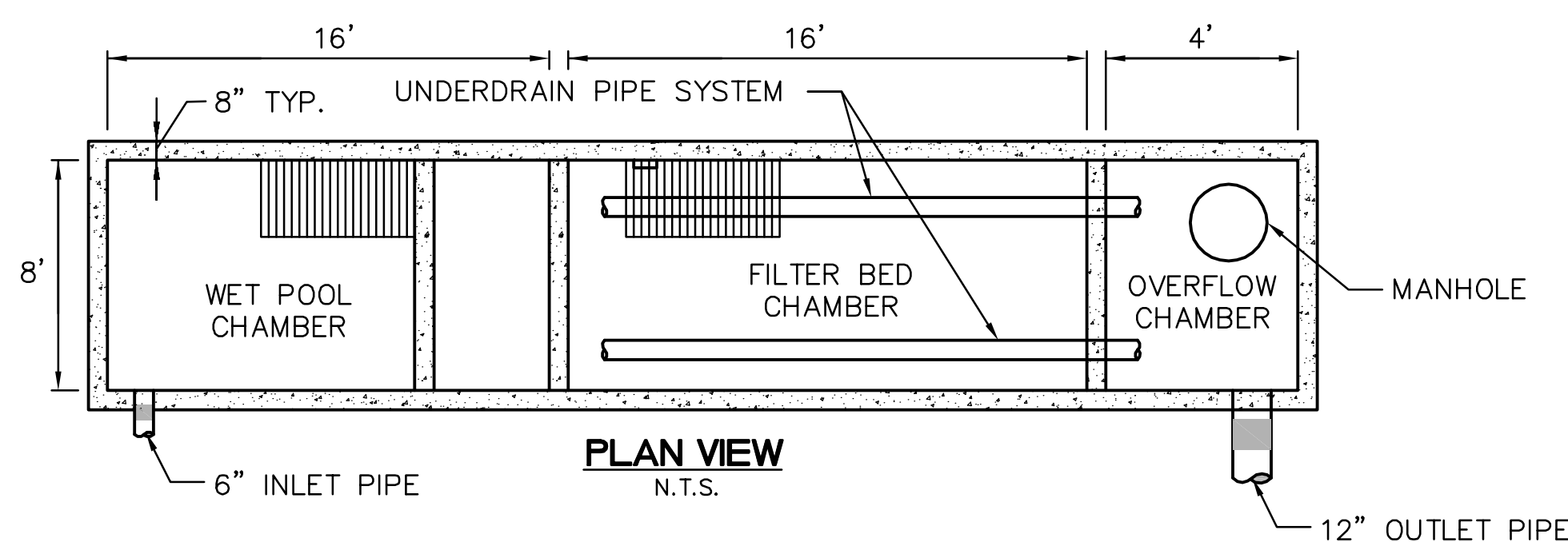

PLAN VIEW
N.T.S.

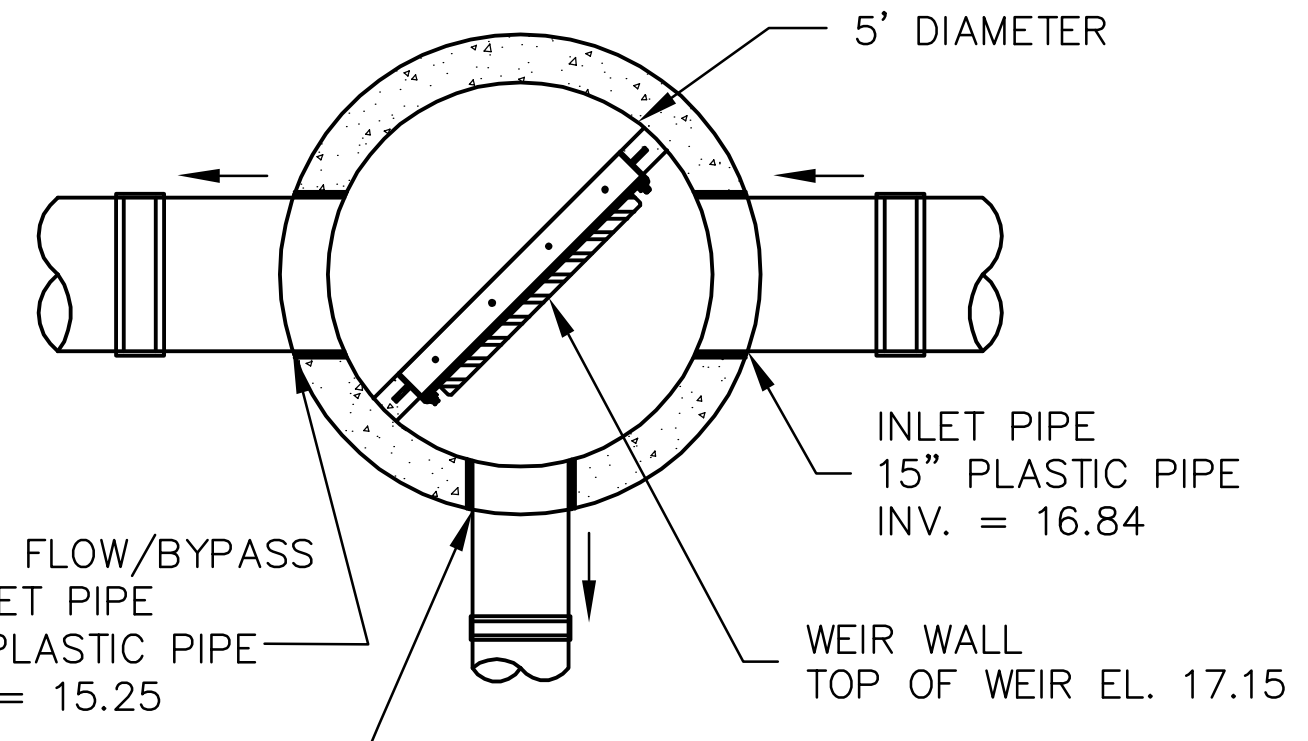

FLOW CONTROL STRUCTURE
PLAN VIEW
N.T.S.

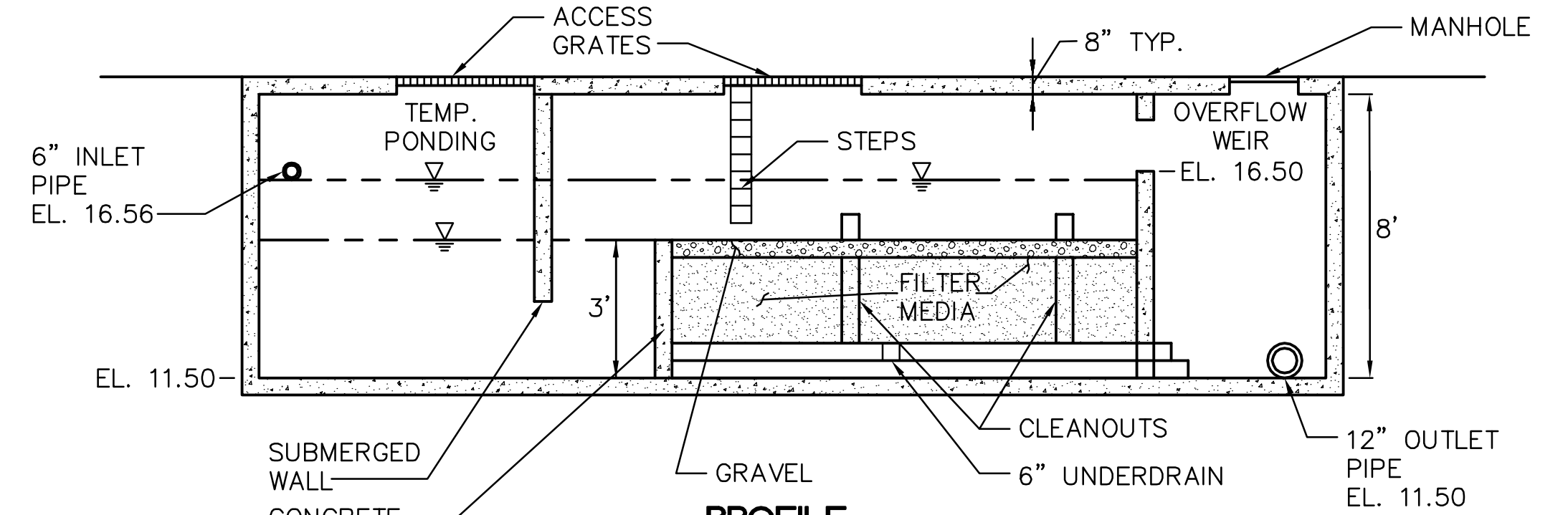

PROFILE
N.T.S.

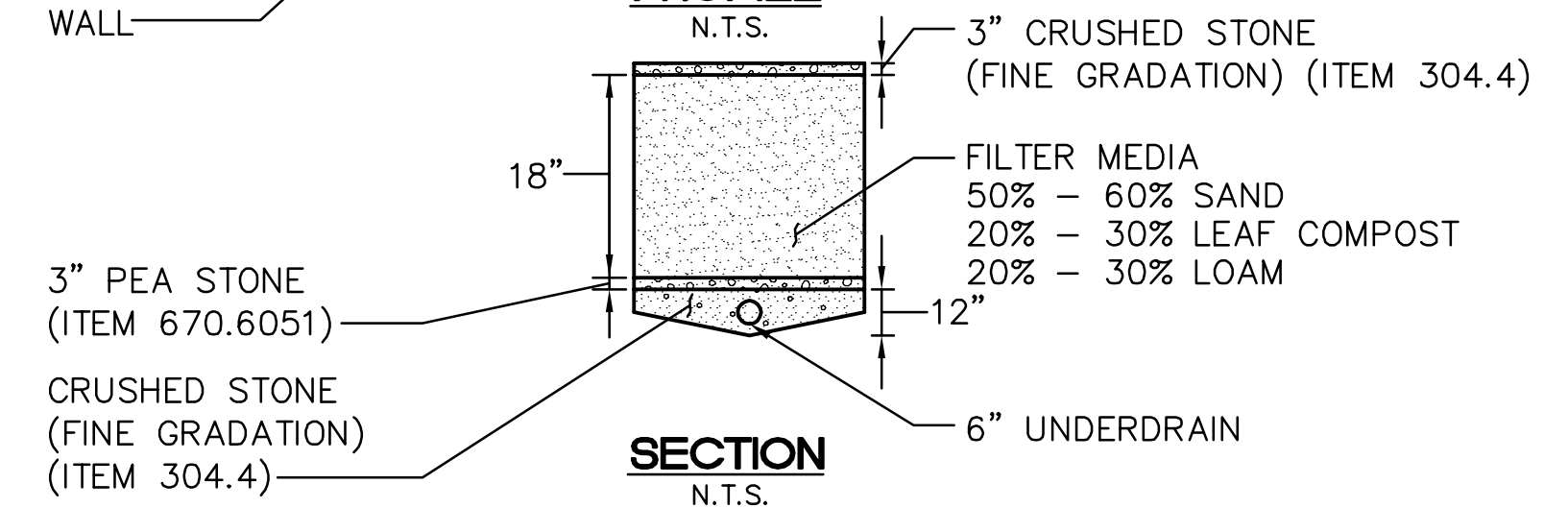

SECTION
N.T.S.

UNDERGROUND SAND FILTER

NOT TO SCALE

OUTLET PROTECTION SUMMARY TABLE						
DRAIN NOTE NUMBER	Q (cfs)	L _a (ft)	W _b (ft)	W _e (ft)	STONE CLASS	THICKNESS (ft)
S2	1.53	10.7	3.8	12.0	C	1
S4	0.82	9.8	3.8	11.1	C	1
S8	5.13	11.0	3.8	5.7	C	1

* SLOPES ARE NOTED ON CROSS-SECTIONS.

NOT TO SCALE
(Except as noted)
FAY, SPOFFORD & THORNDIKE, LLC

CITY OF PORTSMOUTH			
DEPARTMENT OF PUBLIC WORKS			
MISCELLANEOUS DETAILS			
FEDERAL PROJECT NO. X-A000(417)	STATE PROJECT NO. 14493	SHEET NO. 11	TOTAL SHEETS 91

EXISTING DETAIL	ARM	REVISIONS AFTER PROPOSAL		STATION	DESCRIPTION
		NUMBER	DATE		
PROPOSED DESIGN	DEM	NOTEBOOKS		STATION	DESCRIPTION
		BOOK	PAGE		
SHEET CHECKED	TAT	DATE		STATION	DESCRIPTION
		DATE	DATE		
AS BUILT DETAILS		DATE		STATION	DESCRIPTION
DATE		DATE			

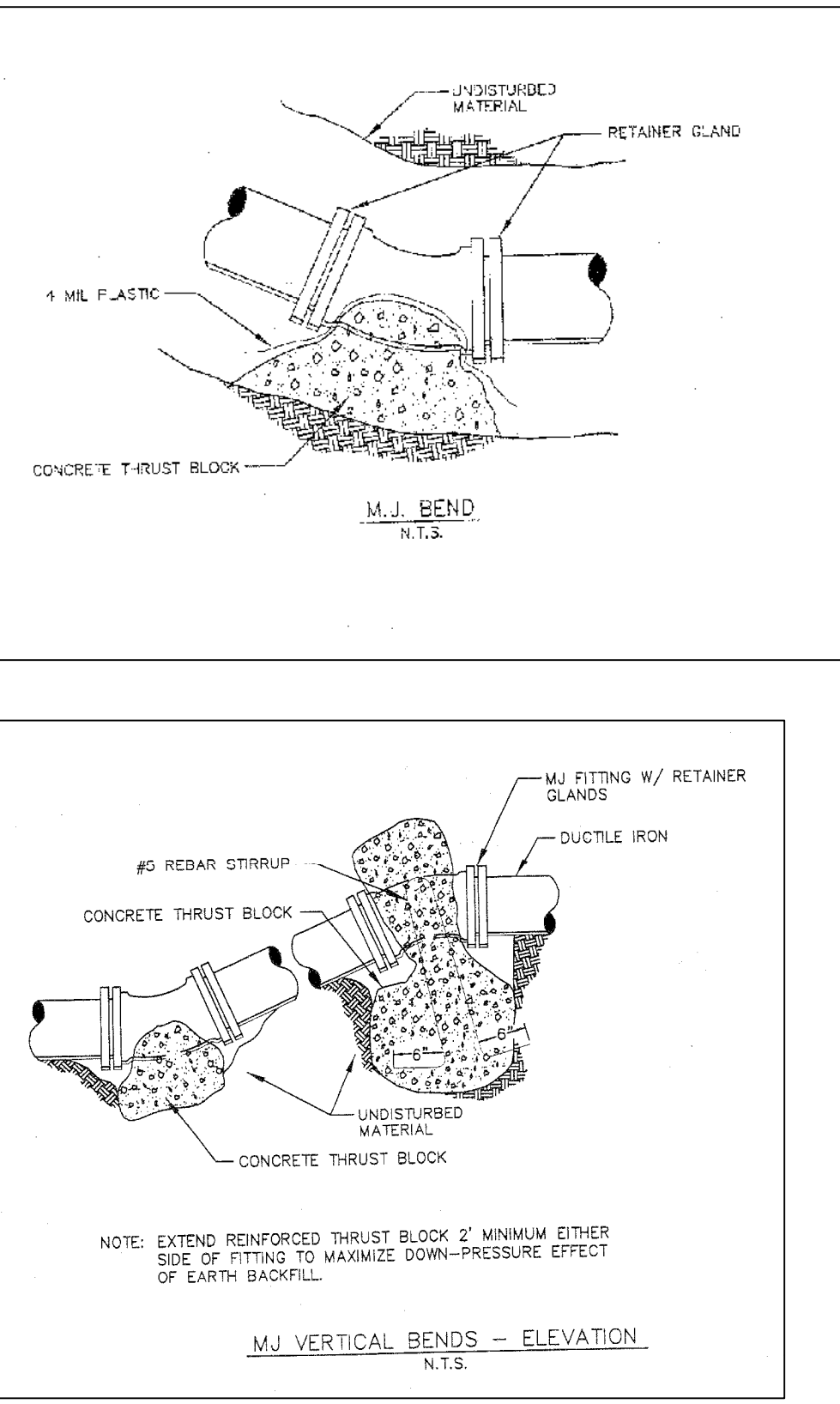
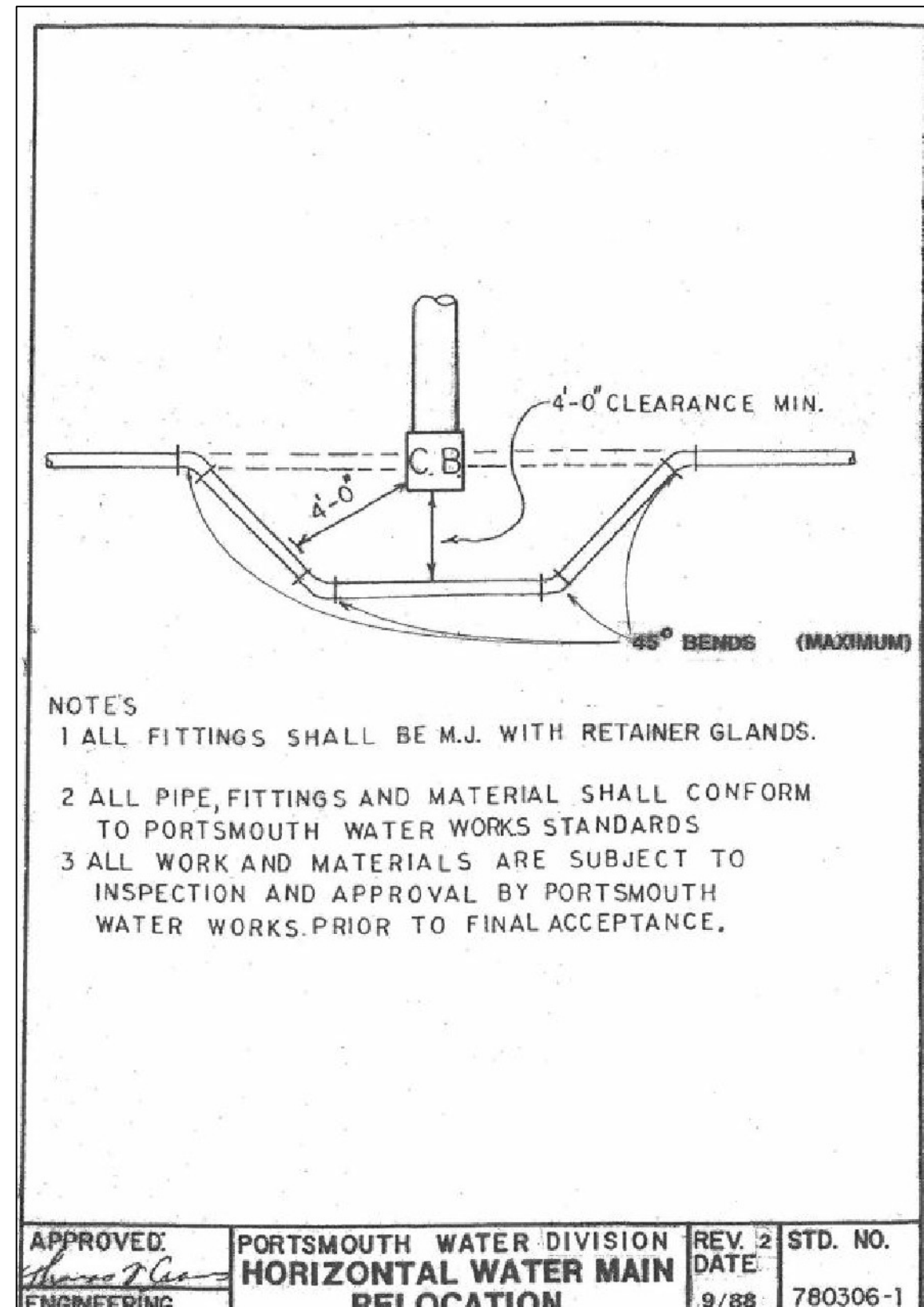
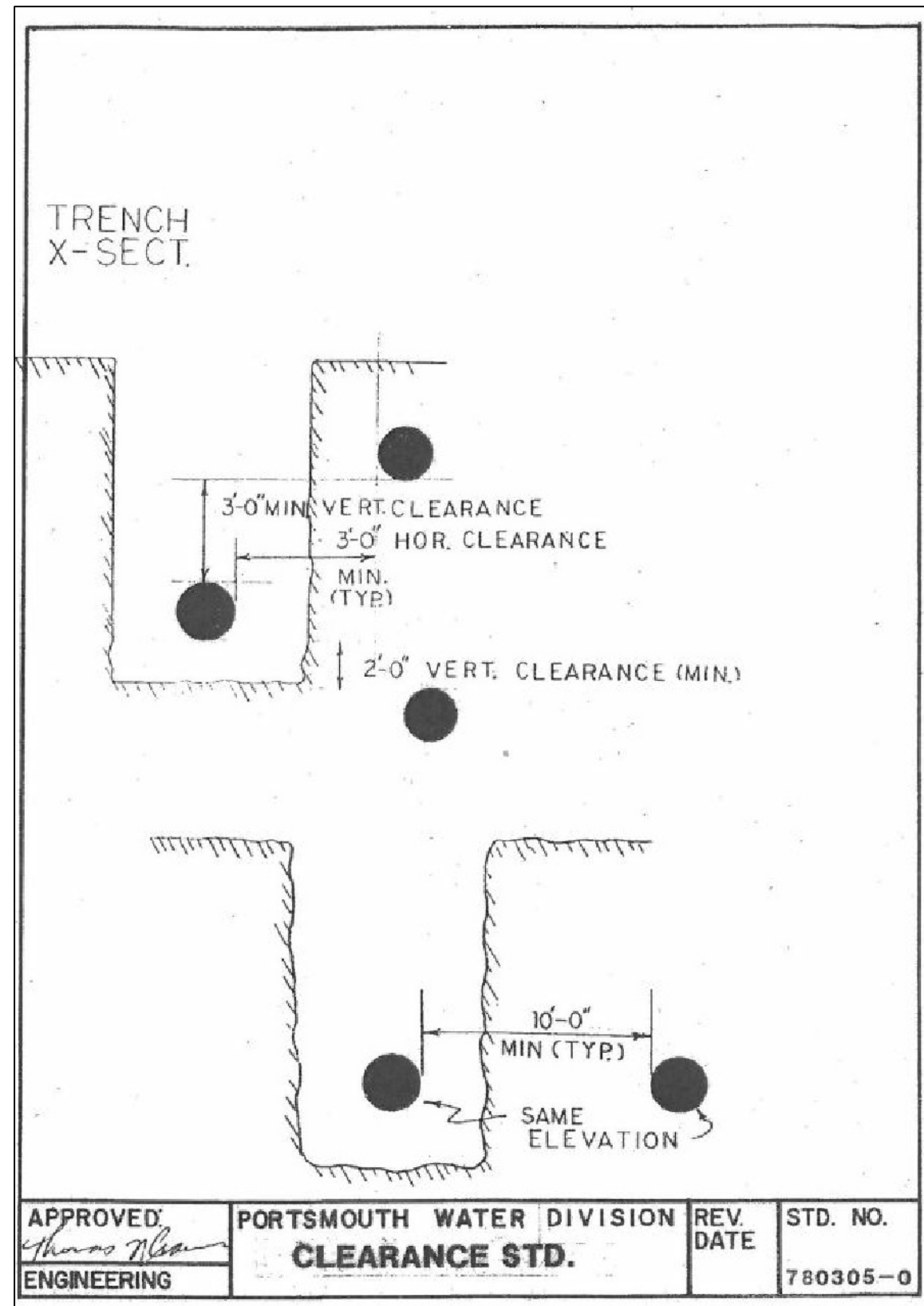
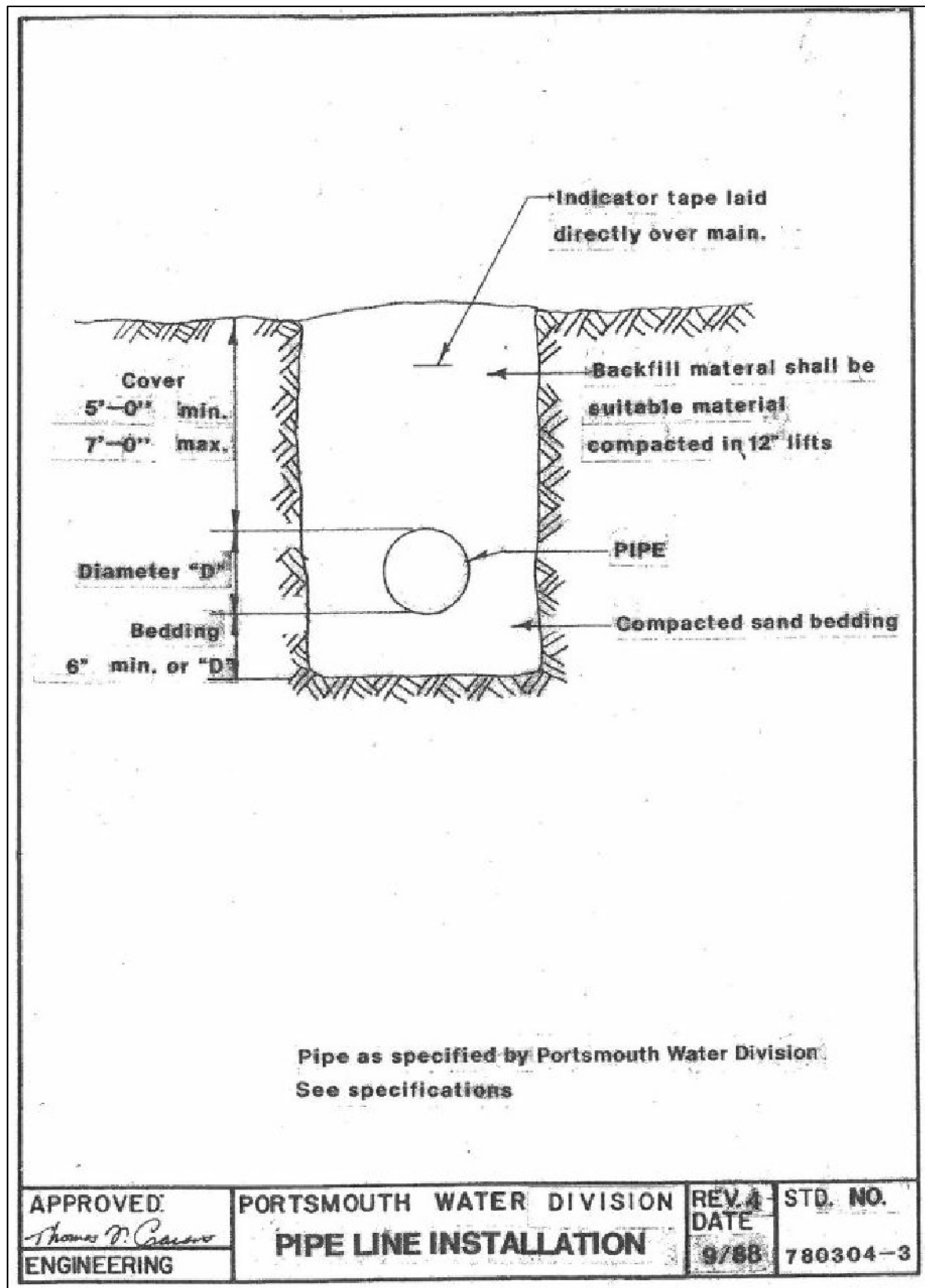

THRUST BLOCK BEARING AREA IN SQ. FT. (PRESSURE = 150 PSI, FACTOR OF SAFETY = 2.0)

FITTINGS	WET SILT & SOFT CLAY	SILT	SAND	COARSE SAND & GRAVEL	HARDPAN
16" TEE, CAP	60.3	30.2	20.1	15.1	12.1
1/4 BEND	85.3	42.7	28.4	21.3	17.1
1/8 BEND	46.2	23.1	15.4	11.5	9.2
1/16 BEND	23.5	11.8	7.8	5.9	4.7
1/32 BEND	11.8	5.9	3.9	3.0	2.4
12" TEE, CAP	33.9	17.0	11.3	8.5	6.8
1/4 BEND	48.0	24.0	18.0	12.0	9.6
1/8 BEND	25.0	13.0	8.7	6.5	5.2
1/16 BEND	13.2	6.6	4.4	3.3	2.6
1/32 BEND	6.7	3.3	2.2	1.7	1.5
10" TEE, CAP	23.5	11.8	7.9	5.9	4.7
1/4 BEND	33.3	16.7	11.1	8.3	6.7
1/8 BEND	18.0	9.0	6.0	4.5	3.6
1/16 BEND	9.2	4.6	3.1	2.3	1.8
1/32 BEND	4.6	2.3	1.5	1.1	0.9
8" TEE, CAP	15.1	7.5	5.0	3.8	3.0
1/4 BEND	21.3	10.7	7.1	5.3	4.3
1/8 BEND	11.5	5.8	3.8	2.9	2.3
1/16 BEND	6.0	2.9	2.0	1.5	1.2
1/32 BEND	3.0	1.5	1.0	0.7	0.6
6" TEE, CAP	8.5	4.2	2.8	2.1	1.7
1/4 BEND	12.0	6.0	4.0	3.0	2.4
1/8 BEND	6.5	3.2	2.2	1.6	1.3
1/16 BEND	3.3	1.7	1.1	0.8	0.6
1/32 BEND	1.7	1.0	0.7	0.5	0.4
4" TEE, CAP	3.8	1.9	1.3	0.9	0.8
1/4 BEND	5.3	2.7	1.8	1.3	1.0
1/8 BEND	2.9	1.4	1.0	0.7	0.6
1/16 BEND	1.5	0.7	0.5	0.4	0.3
1/32 BEND	0.7	0.4	0.3	0.2	0.2
3" TEE, CAP	2.1	1.1	0.7	0.5	0.4
1/4 BEND	3.0	1.5	1.0	0.7	0.6
1/8 BEND	1.6	0.8	0.5	0.4	0.3
1/16 BEND	0.8	0.4	0.3	0.2	0.2
1/32 BEND	0.5	0.3	0.2	0.1	0.1
2" TEE, CAP	0.9	0.5	0.3	0.2	0.2
1/4 BEND	1.3	0.7	0.5	0.4	0.3
1/8 BEND	0.7	0.4	0.3	0.2	0.2
1/16 BEND	0.4	0.2	0.1	0.1	0.1
1/32 BEND	0.2	0.1	0.1	0.1	0.1

SOIL TYPE BEARING CAPACITY (psf)

MUCK -0-

WET SILT & SOFT CLAY 1000

SILT 2000

SAND 3000

COARSE SAND & GRAVEL 4000

HARDPAN 5000

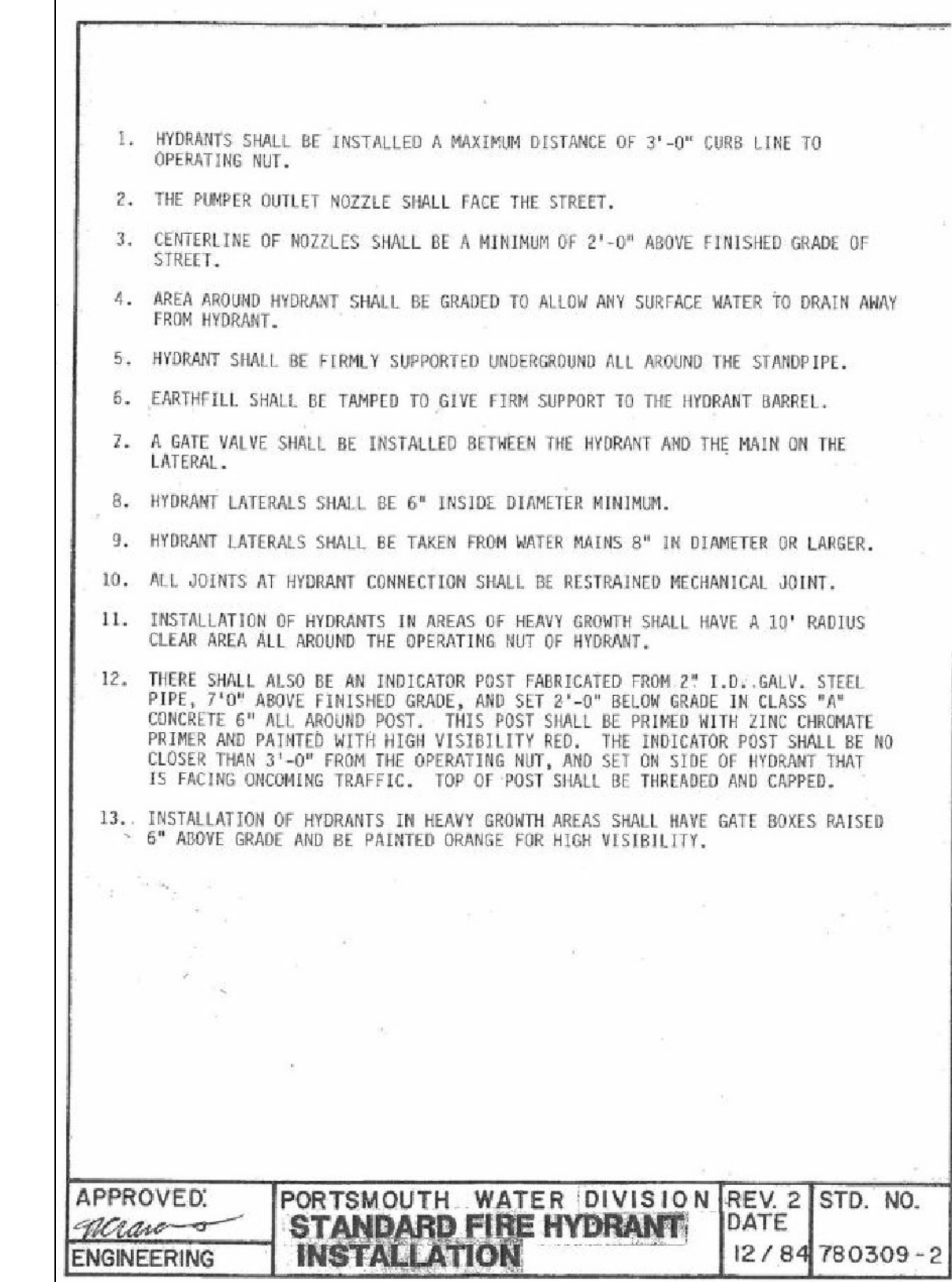
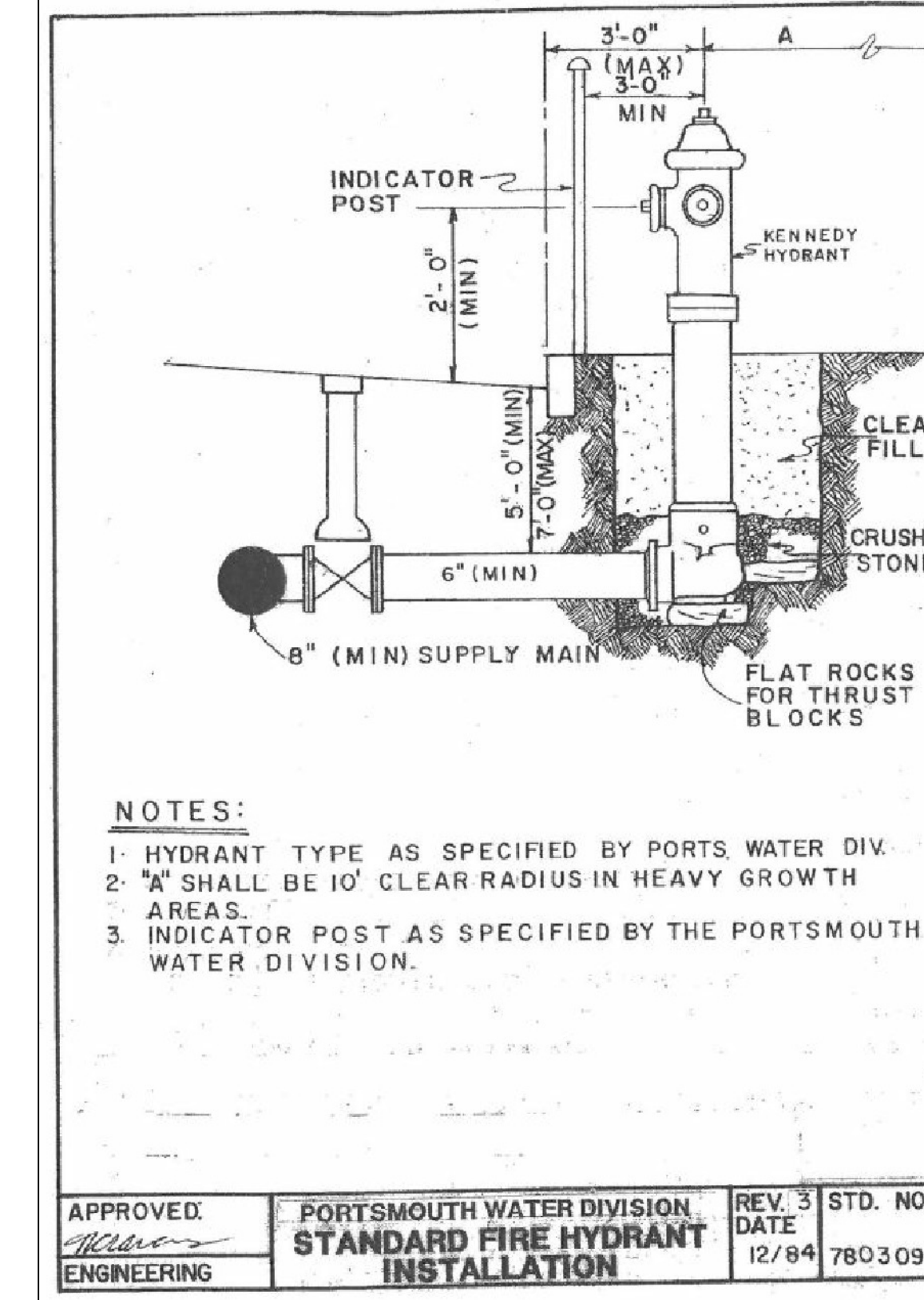
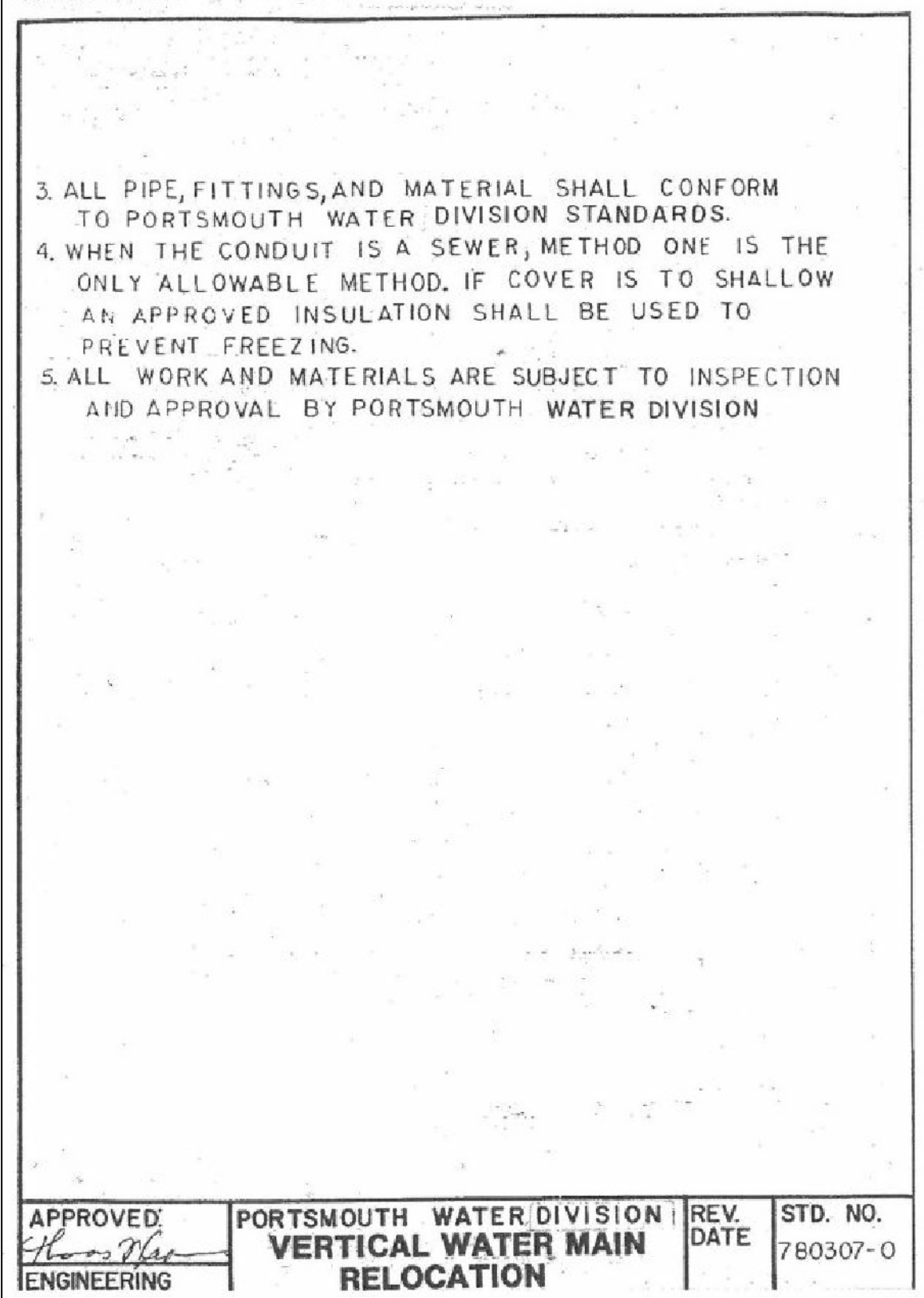
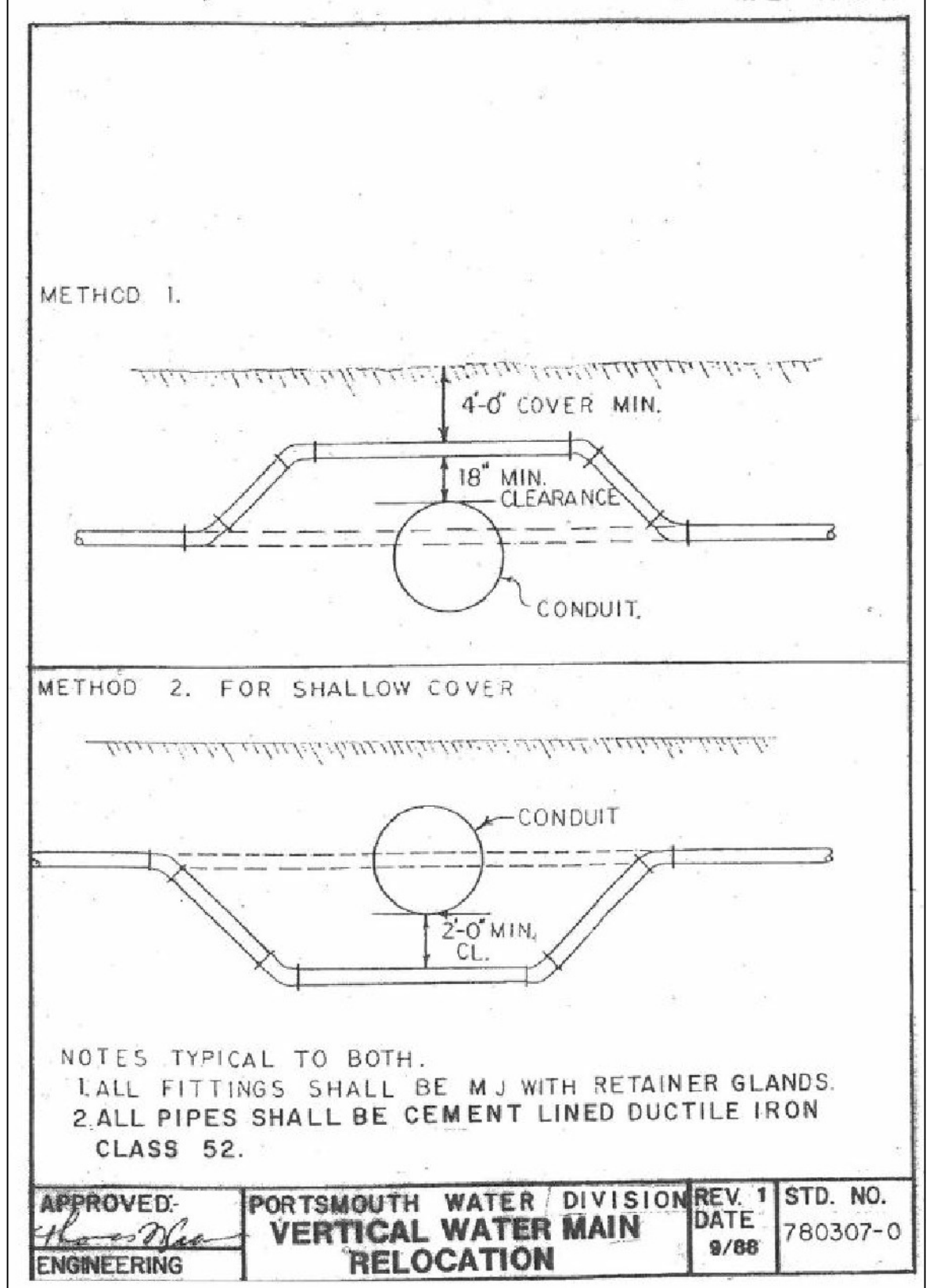

NOTE: REFER TO PAVEMENT LAYOUT PLANS AND CROSS-SECTIONS FOR DRIVEWAY LENGTHS, WIDTHS, RADII, CURB CUTS, GRADES AND PAVEMENT & BASE COURSE DEPTHS

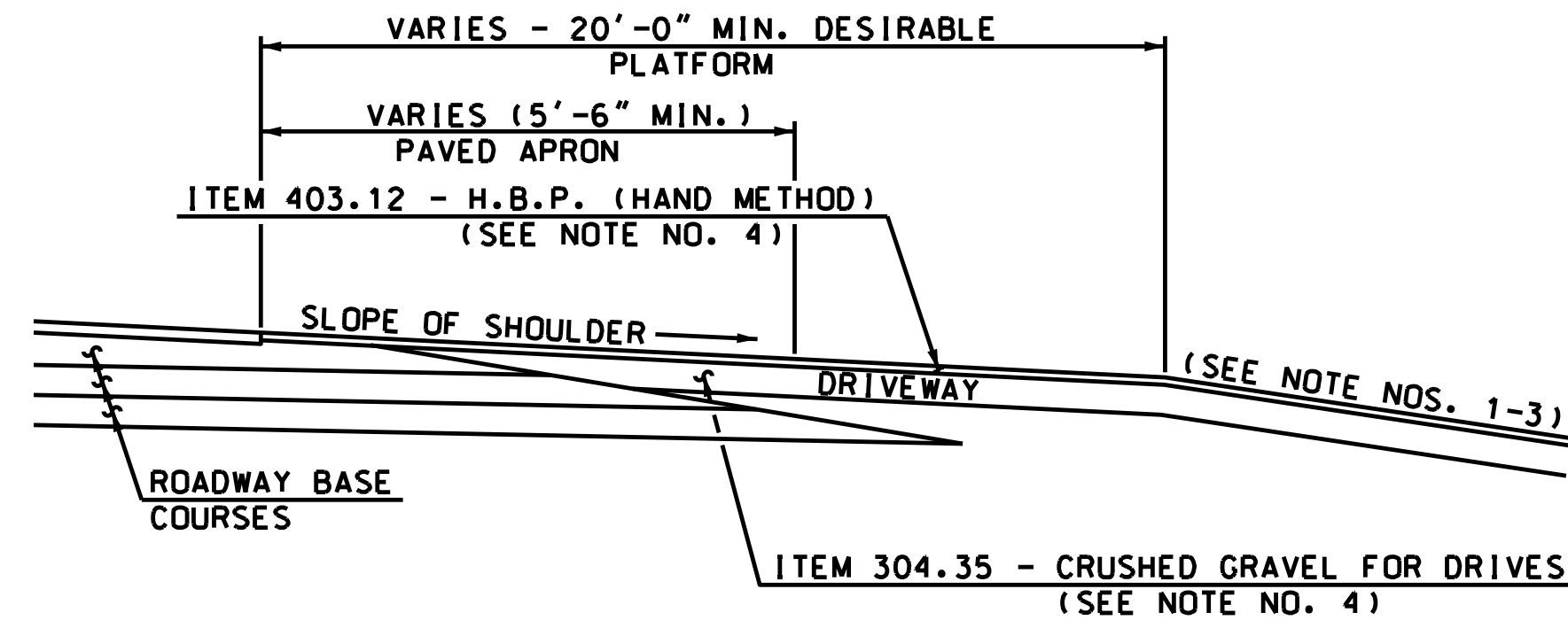

TYPICAL UNCURBED DRIVE IN FILL SECTION

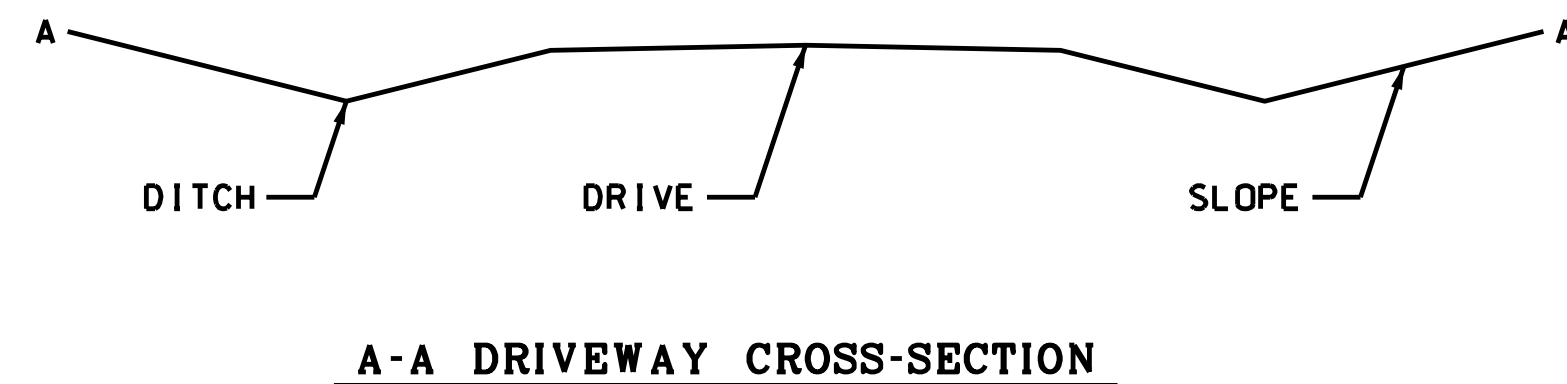
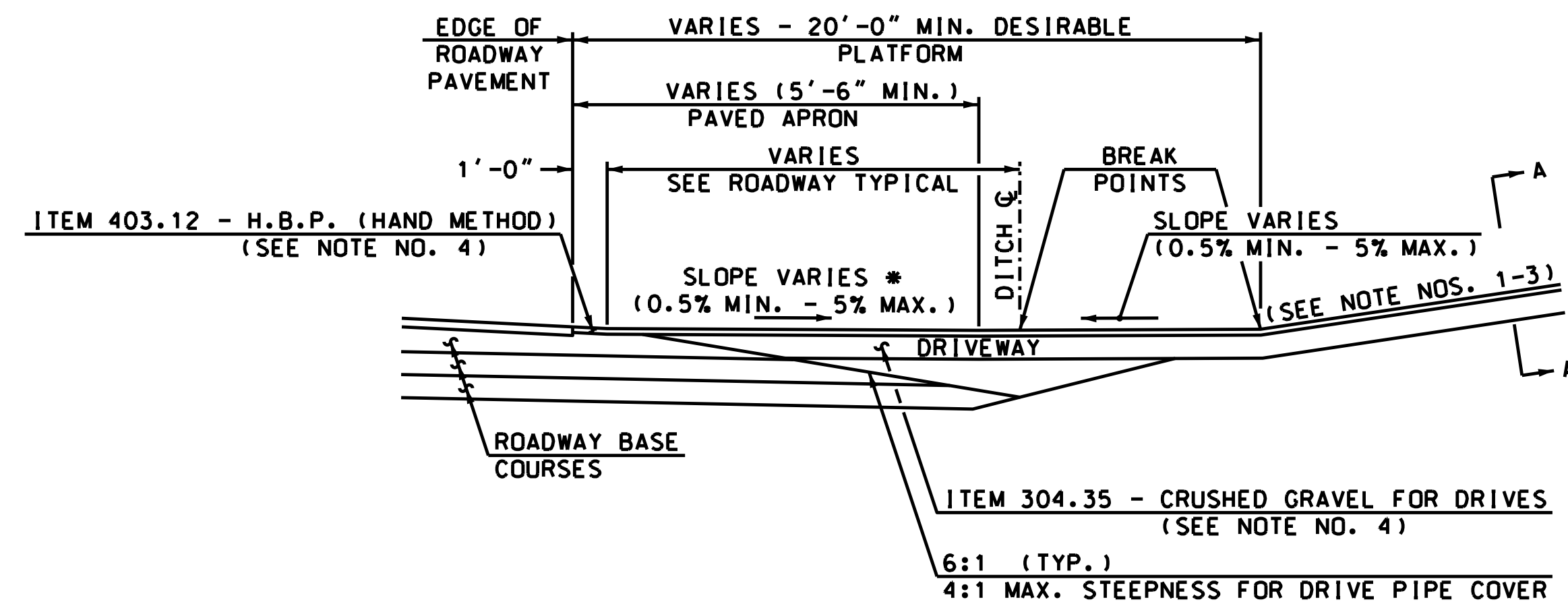

TYPICAL UNCURBED DRIVE IN CUT SECTION

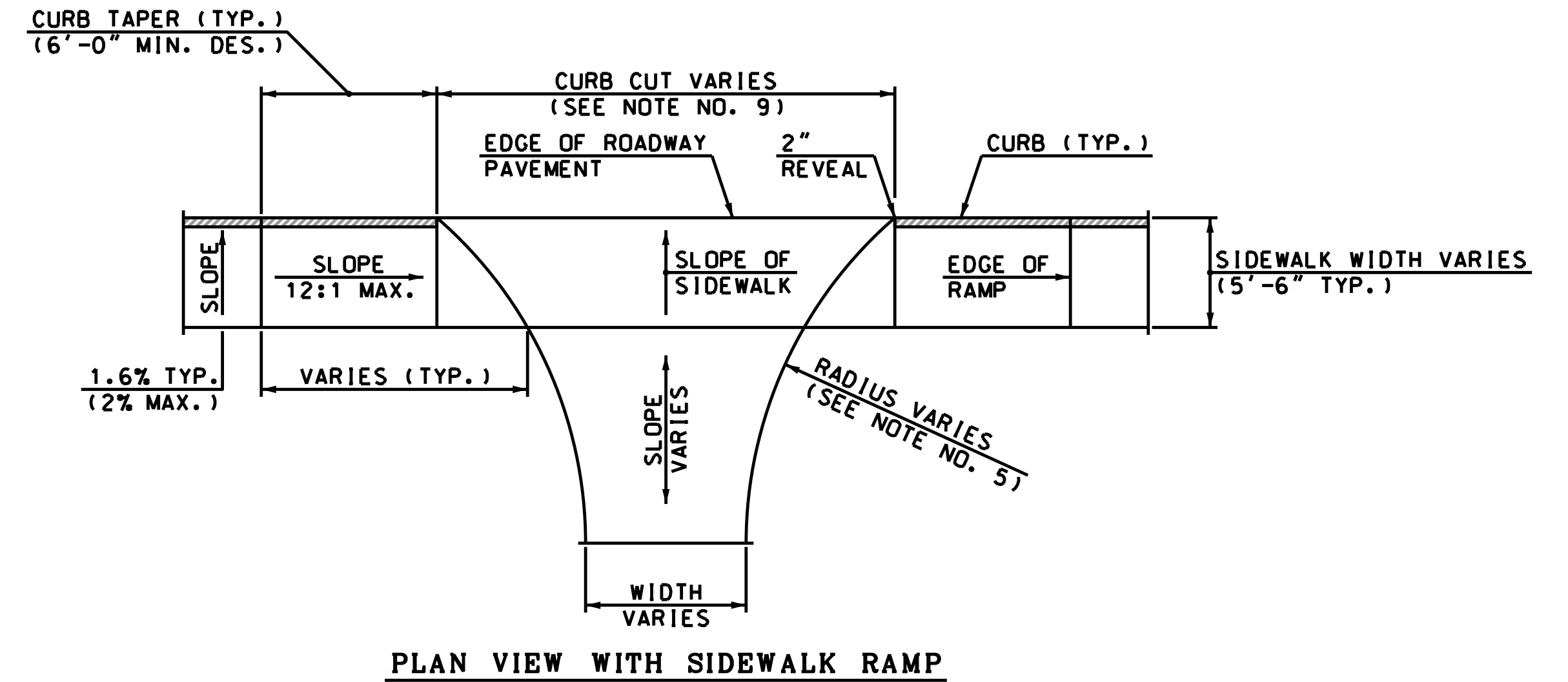

PLAN VIEW WITH SIDEWALK RAMP

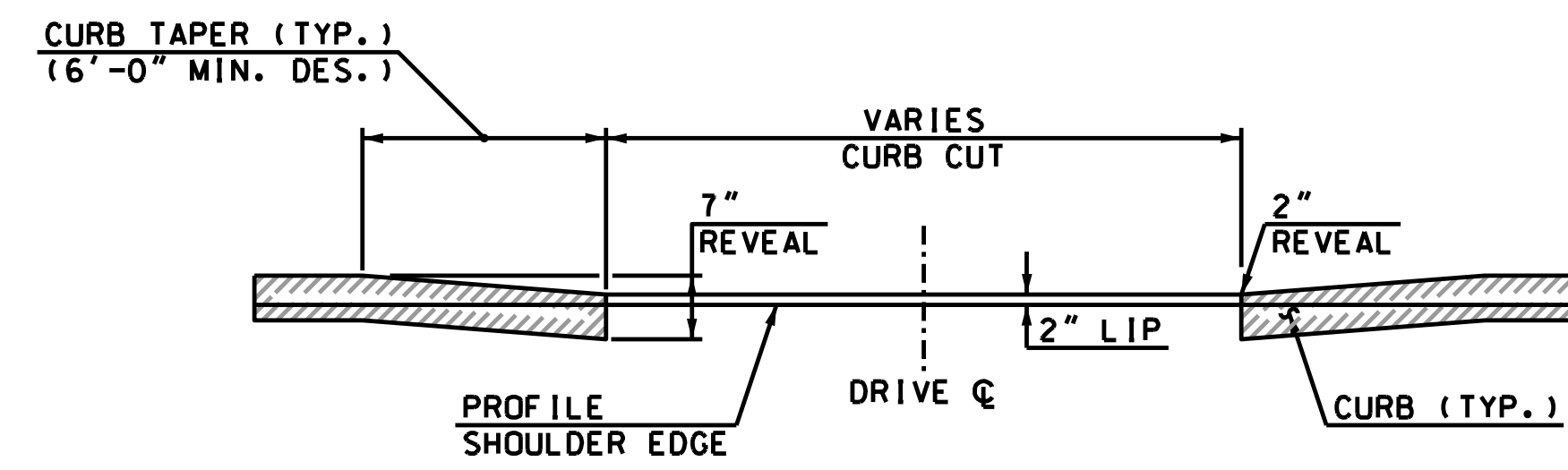

END VIEW

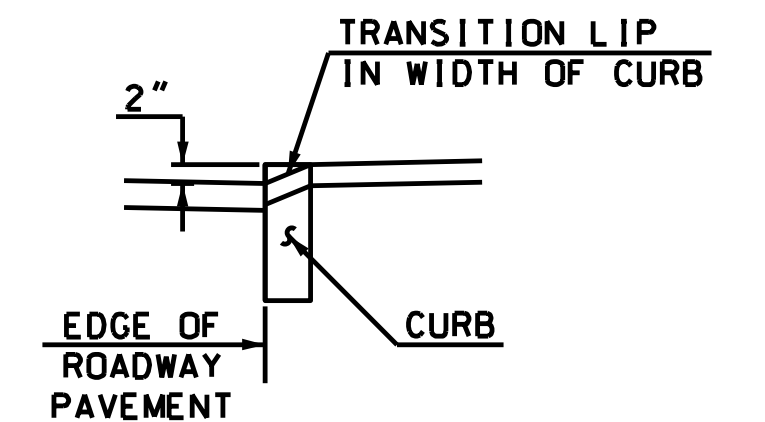

LIP DETAIL

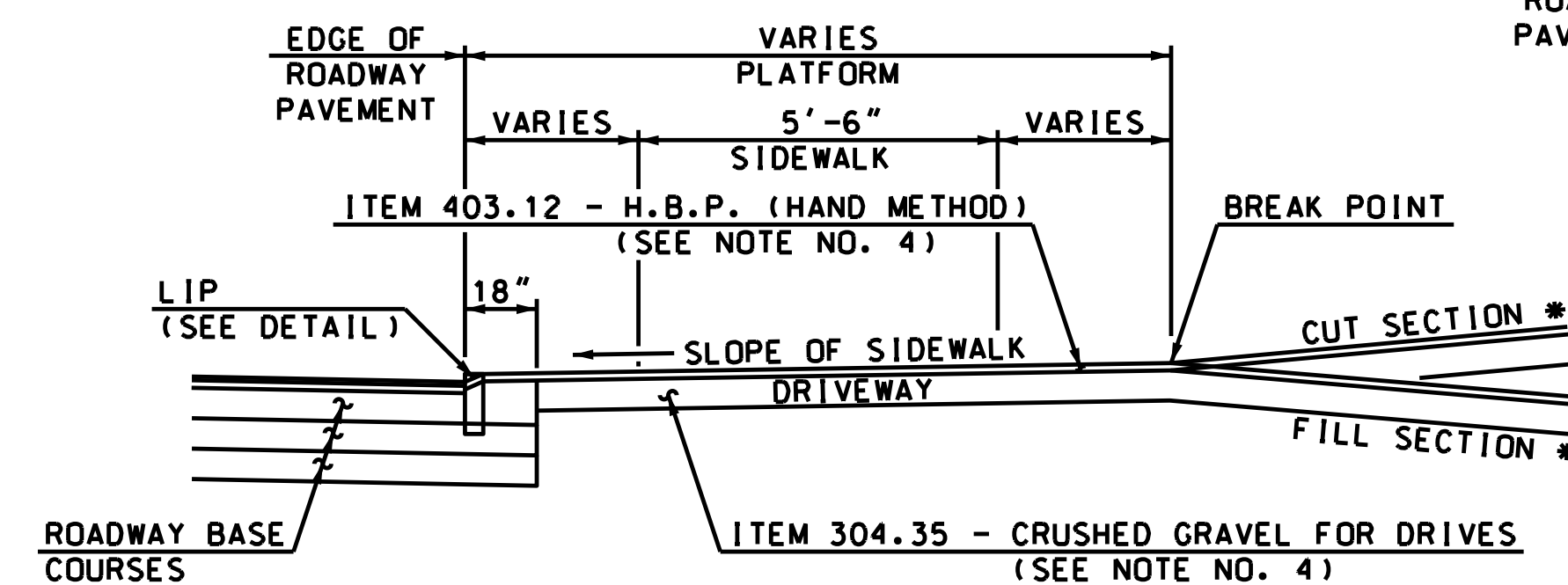

TYPICAL URBAN CURBED DRIVE IN CUT/FILL SECTION

GENERAL NOTES

1. GRADES OF MAJOR ENTRANCES BEYOND THE PLATFORM SHOULD NOT EXCEED 8%.
2. GRADES OF OTHER DRIVES BEYOND THE PLATFORM SHOULD NOT EXCEED 15%.
3. THE ALGEBRAIC DIFFERENCE BETWEEN TWO ADJACENT GRADES SHOULD NOT EXCEED 10%.
4. PAVEMENT AND BASE COURSE DEPTHS ARE:
 - A. TYPICALLY 8" CRUSHED GRAVEL WITH 3" HBP (HAND METHOD, PLACED IN 2 COURSES) FOR RESIDENTIAL DRIVES ADJACENT TO ROADWAYS WITH CONVENTIONAL CRUSHED GRAVEL, GRAVEL, AND SAND STRUCTURAL BOX. IF THE DRIVE IS ADJACENT TO A ROADWAY WITH A CRUSHED STONE STRUCTURAL BOX, 6" OF CRUSHED STONE FINE GRADATION MAY BE SUBSTITUTED FOR THE 8" OF CRUSHED GRAVEL NOTED ABOVE.
 - B. TYPICALLY 12" CRUSHED GRAVEL WITH 3" HBP (HAND METHOD, PLACED IN 2 COURSES) FOR COMMERCIAL DRIVES WITH FREQUENT HEAVY TRUCK TRAFFIC THAT ARE ADJACENT TO ROADWAYS WITH CONVENTIONAL CRUSHED GRAVEL, GRAVEL, AND SAND STRUCTURAL BOX. IF THE DRIVE IS ADJACENT TO A ROADWAY WITH A CRUSHED STONE STRUCTURAL BOX, 9" OF CRUSHED STONE FINE GRADATION MAY BE SUBSTITUTED FOR THE 12" OF CRUSHED GRAVEL NOTED ABOVE.
5. FOR DESIGN CRITERIA AND OTHER ADDITIONAL INFORMATION, REFER TO THE NHDOT DRIVEWAY MANUAL.
6. DITCHES ARE RECOMMENDED FOR UNCURBED DRIVEWAYS IN CUT SLOPES.
7. USE SLOPED END SECTIONS ON DRIVE PIPES FOR UNCURBED DRIVEWAYS.
8. CURBING CAN BE FLARED TO FIT DRIVE RADII IF APPROPRIATE OR ENDED AS DETAILED ABOVE.
9. CURB CUTS FOR RESIDENTIAL DRIVES WITH ANGLES OF ENTRY OF 75°-90° ARE TYPICALLY 20'-0", UNLESS OTHERWISE NOTED ON THE PLANS.

CITY OF PORTSMOUTH				
DEPARTMENT OF PUBLIC WORKS				
DRIVEWAY DETAILS				
REVISION DATE	DGN	STATE PROJECT NO.	SHEET NO.	TOTAL SHEETS
06/04/12		14493	13	91

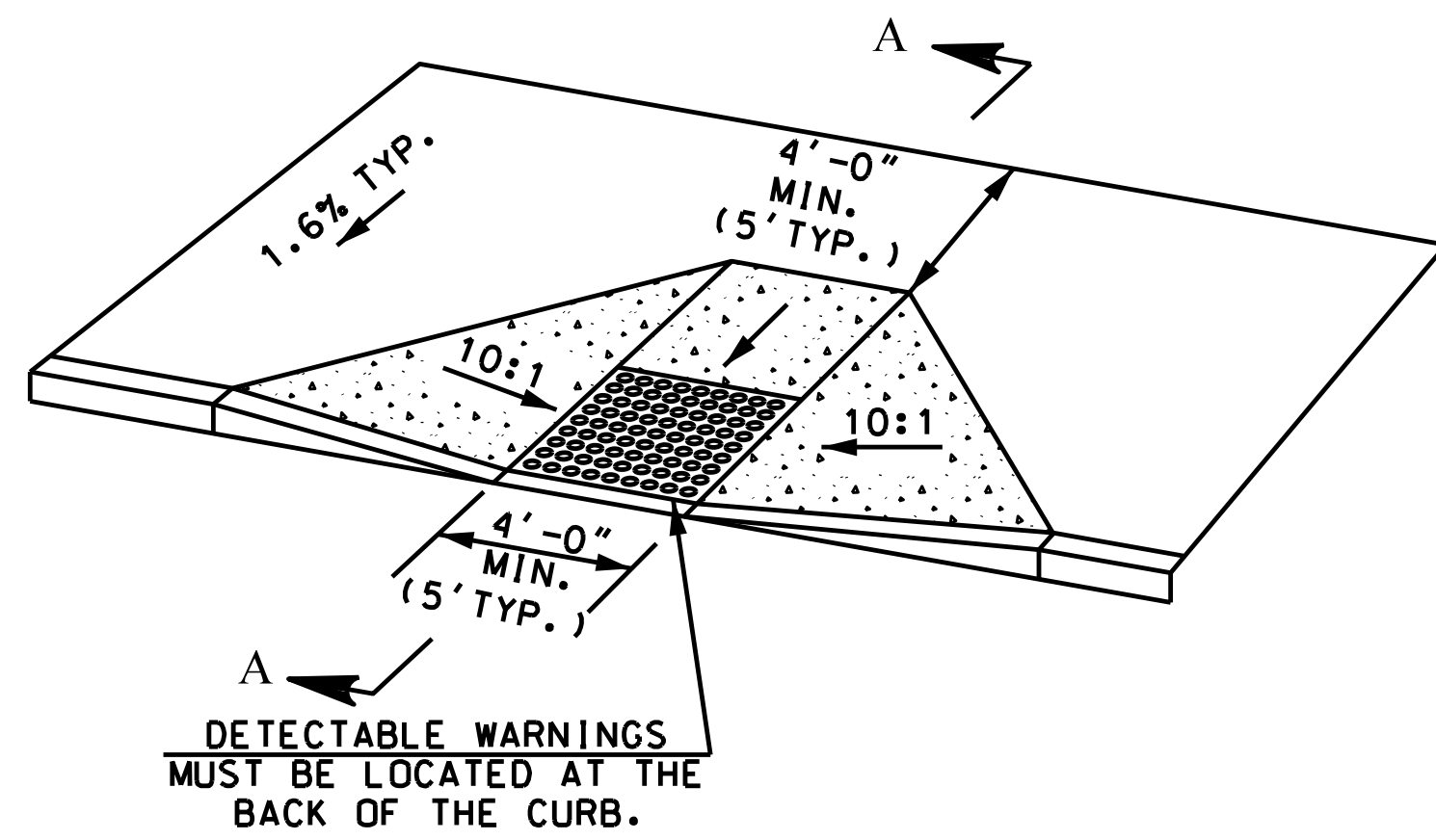

PERPENDICULAR CURB RAMP DETAIL

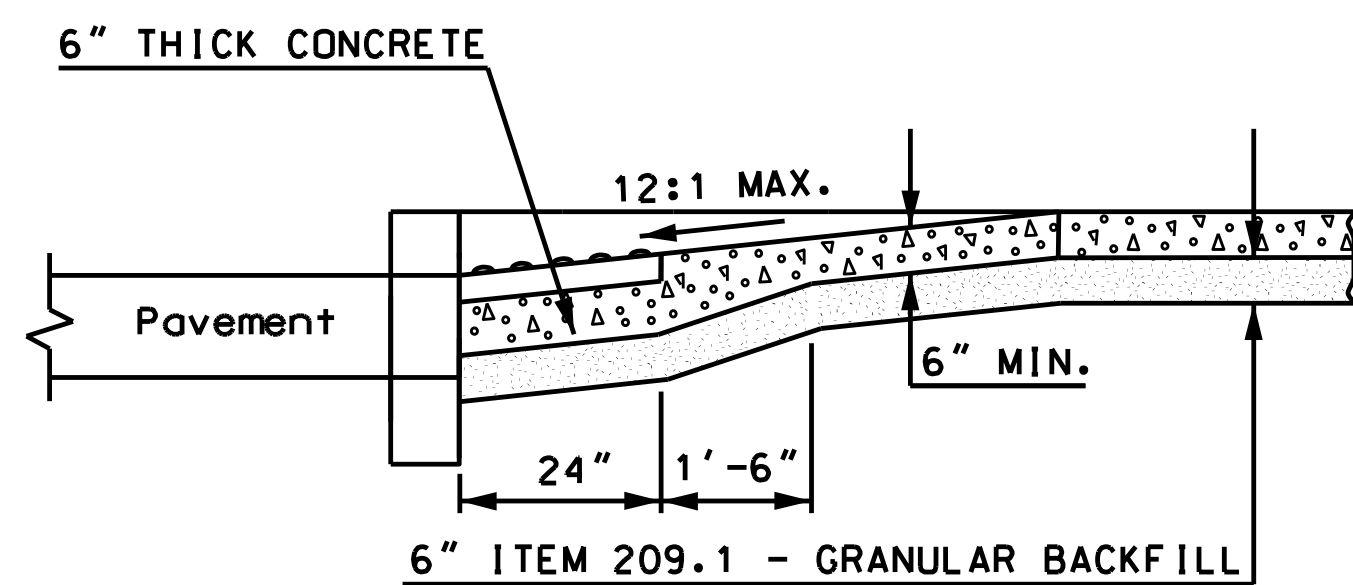

SECTION A-A

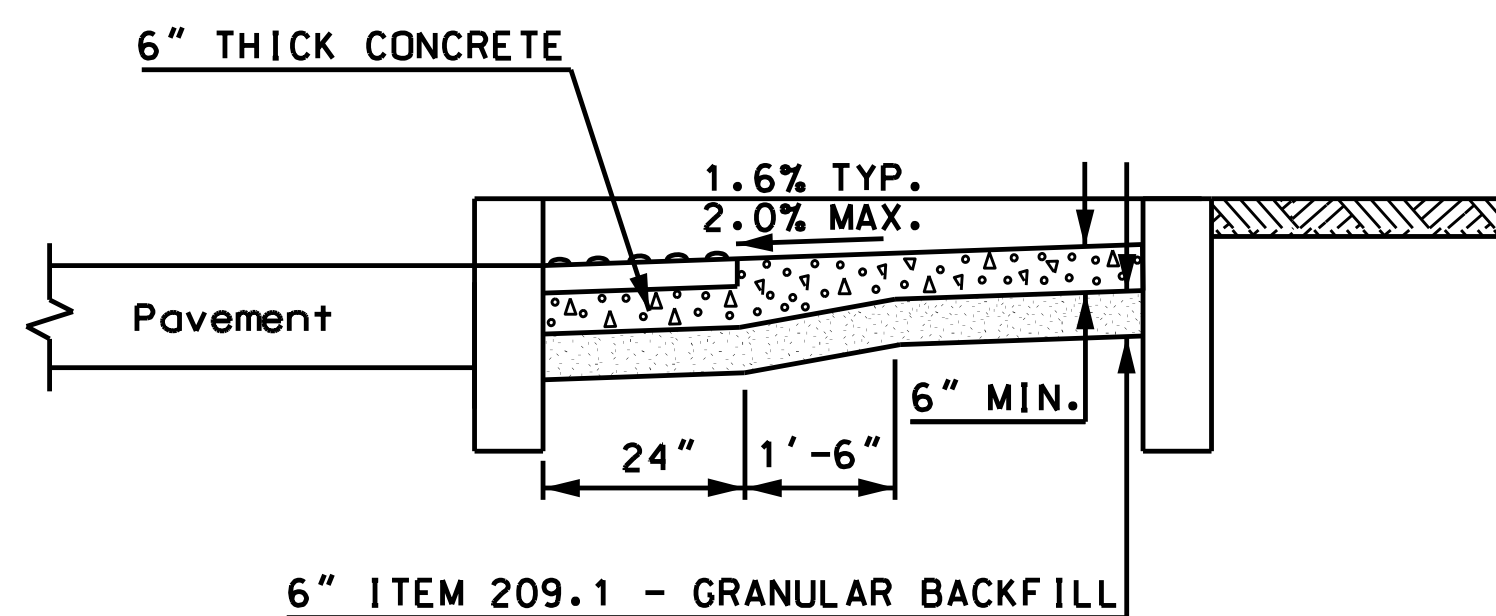

SECTION B-B

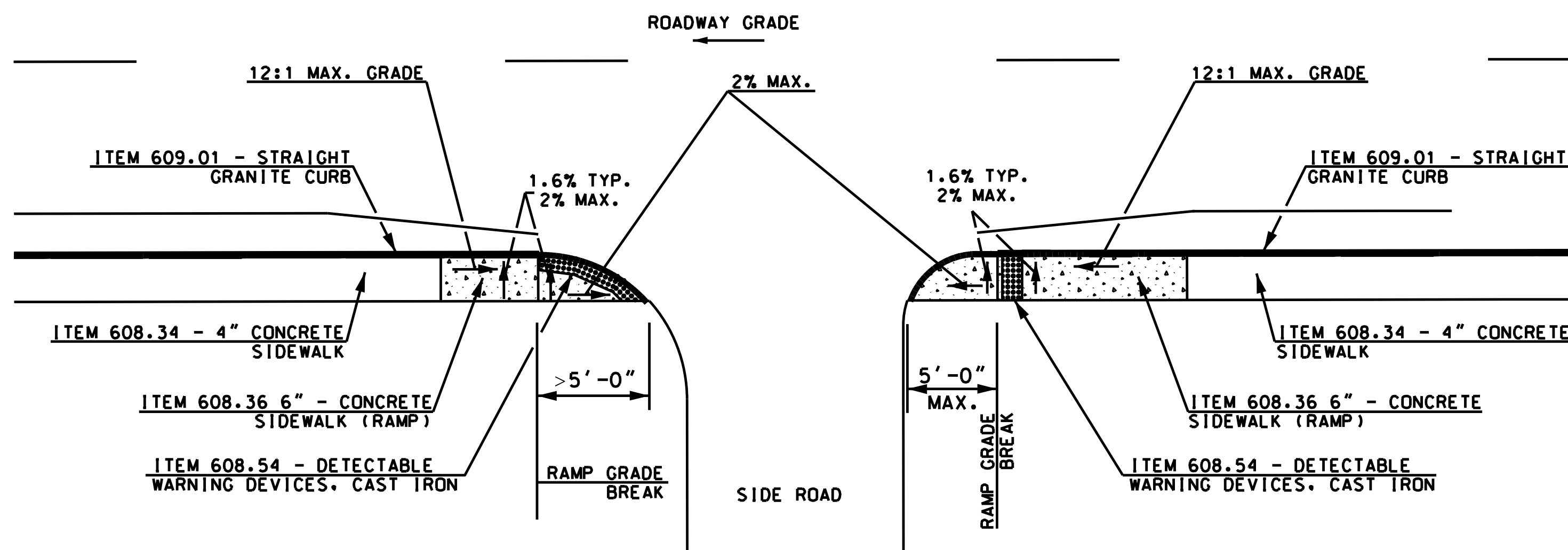

PERPENDICULAR RAMP WITH GRASS PANEL

* LENGTH OF RAMP VARIES WITH SLOPE & WIDTH OF GRASS PANEL

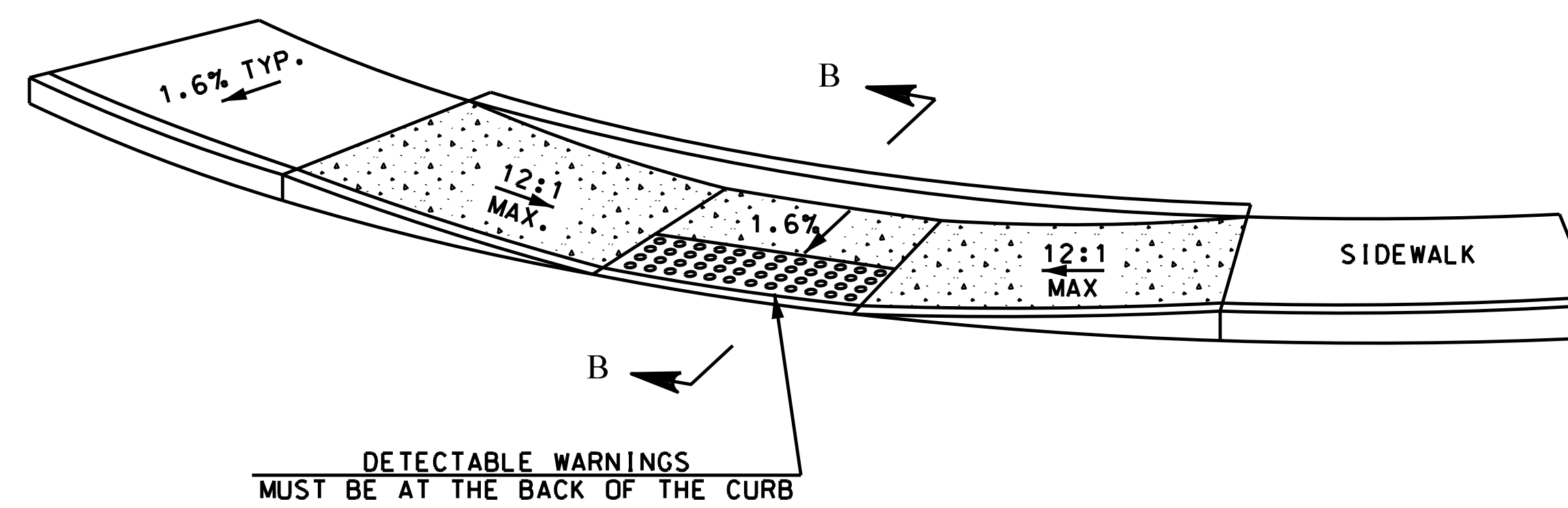

PARALLEL CURB RAMP DETAIL

TRANSITION RAMPS:

BLENDED TRANSITIONS HAVE A RUNNING SLOPE GREATER THAN 2% BUT LESS THAN 5%. CURB RAMPS HAVE A RUNNING SLOPE OF 5% MIN. TO 8.33% MAX. SIDEWALK, BLENDED TRANSITIONS, AND CURB RAMPS HAVE A MAX. CROSS SLOPE OF 2%.

ALL GRADE BREAKS BETWEEN LANDINGS, RAMPS, AND BLENDED TRANSITIONS SHALL BE PERPENDICULAR TO THE DIRECTION OF TRAVEL.

IF IT IS NECESSARY TO USE SIDEWALK WIDTHS 5'-0" OR LESS, PROVIDE A WIDENED AREA A MINIMUM OF 5'-0" WIDE BY 5'-0" LONG SPACED AT INTERVALS OF 200' MAXIMUM TO ALLOW FOR USERS TO PASS EACH OTHER.

PROVIDE DETECTABLE WARNING SURFACES ANYTIME THAT A CURB RAMP, BLENDED TRANSITION, OR LANDING CONNECTS TO A STREET. PLACEMENT FOR DETECTABLE WARNING SURFACES ARE AS FOLLOWS:

PERPENDICULAR CURB RAMPS:

WHERE BOTH ENDS OF THE BOTTOM GRADE ARE LESS THAN 5'-0" FROM THE BACK OF THE CURB, LOCATE THE DETECTABLE WARNING PANELS ON THE RAMP SURFACE AT THE BOTTOM OF THE RAMP. WHERE EITHER END OF THE BOTTOM GRADE IS GREATER THAN 5'-0" FROM THE BACK OF THE CURB, LOCATE THE DETECTABLE WARNINGS AT THE BOTTOM OF THE LANDING.

PARALLEL CURB RAMPS:

LOCATE THE DETECTABLE WARNING SURFACES AT THE BACK OF THE CURB ALONG THE EDGE OF THE LANDING.

FOR BLENDED TRANSITIONS AND LANDINGS:

LOCATE THE DETECTABLE WARNING SURFACES AT THE BACK OF THE CURB.

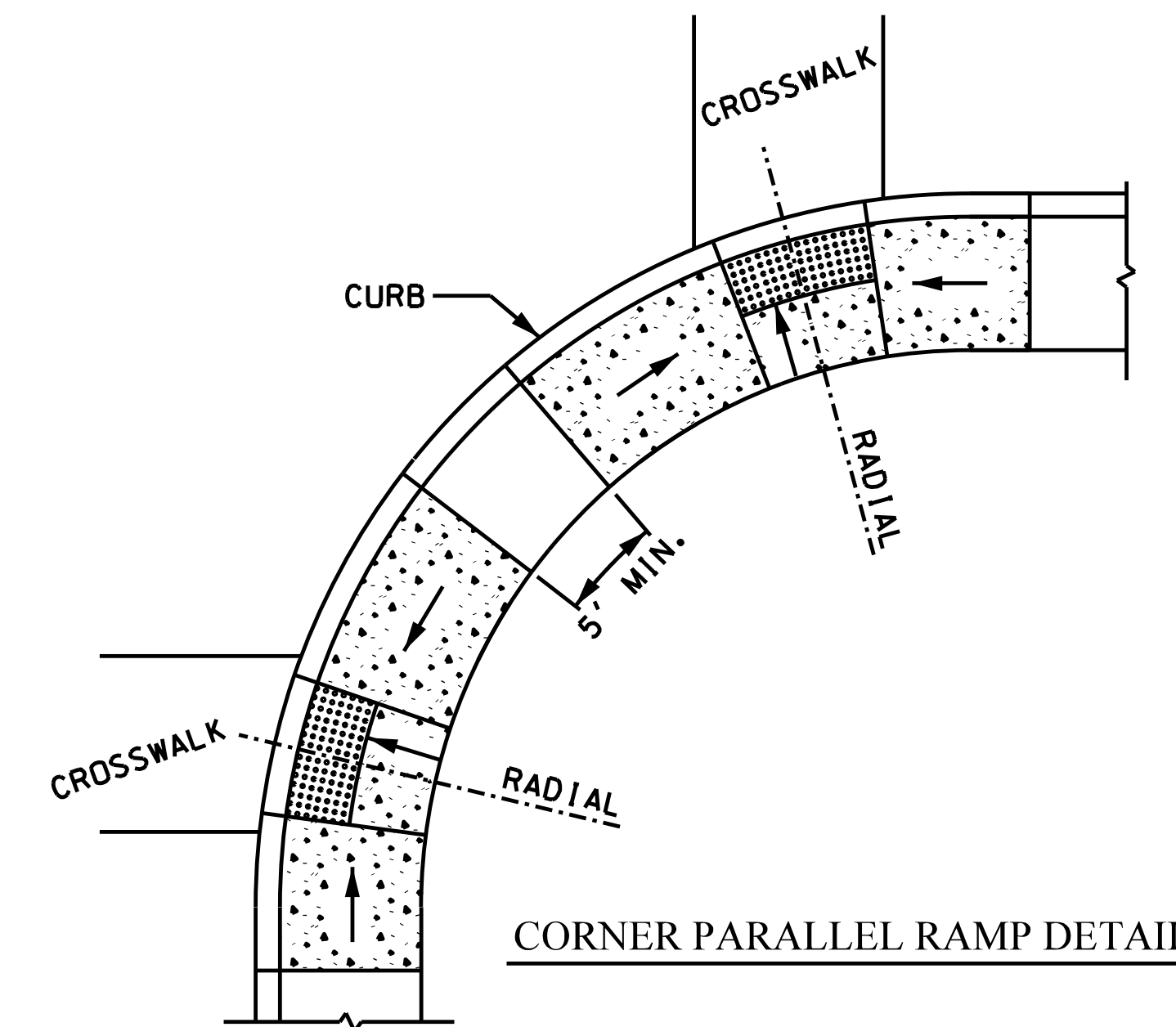

CORNER PARALLEL RAMP DETAIL

THE ORDER OF PREFERENCE FOR LOCATION OF CORNER RAMPS:

1. TWO SEPARATE RAMPS LOCATED ON TANGENT SIDEWALK AREA IMMEDIATELY OUTSIDE OF CORNER RADIUS.
2. TWO SEPARATE RAMPS SEPARATED BY 5' MINIMUM AS SHOWN ABOVE.
3. SINGLE RAMP SERVING TWO CROSSWALKS.

GENERAL NOTES

1. THE MAXIMUM RUNNING SLOPE OF ANY SIDEWALK CURB RAMP IS 12:1, THE MAXIMUM CROSS SLOPE IS 2%. THE SLOPE OF THE LANDING SHALL NOT EXCEED 2% IN ANY DIRECTION.
RAMP RUNNING SLOPE EXCEPTION: A GREATER THAN 8.33% RAMP RUNNING GRADE IS ALLOWED WHERE THE ROADWAY AND THE SIDEWALK(S) ARE PARALLEL AND VERY CLOSE TOGETHER, WITH THE SAME GRADE, AND USING A GRADE OF 8.33% WOULD RESULT IN A RAMP LENGTH LONGER THAN 15'. IN THOSE CIRCUMSTANCES USE A MAXIMUM RAMP LENGTH OF 15' AND THE ALLOWABLE RUNNING SLOPE OF THE RAMP(S) IS GREATER THAN 8.33%.
2. TRANSITIONS SHALL BE FLUSH AND FREE OF ABRUPT CHANGES. ROADWAY SHOULDER SLOPES ADJOINING SIDEWALK CURB RAMPS SHALL BE A MAXIMUM OF 5% (FULL WIDTH) FOR A DISTANCE OF 2 FT. FROM THE ROADWAY CURBLINE.
3. INTERCEPT DRAINAGE ALONG THE CURB IN ADVANCE OF SIDEWALK CURB RAMPS OR LANDINGS. CATCH BASINS, MANHOLES, ETC. SHALL NOT BE LOCATED IN, OR AT THE BASE OF, SIDEWALK CURB RAMPS OR LANDINGS.
4. THE BOTTOM OF THE SIDEWALK CURB RAMP OR LANDING, EXCLUSIVE OF THE FLARED SIDES, SHALL BE WHOLLY CONTAINED WITHIN THE CROSSWALK MARKINGS.
5. THE SURFACE OF A PERPENDICULAR SIDEWALK CURB RAMP OR THE LANDING OF A PARALLEL SIDEWALK CURB RAMP SHALL CONTRAST VISUALLY WITH THE ADJOINING SIDEWALK SURFACE, EITHER ASPHALT/LIGHT-COLORED CONCRETE OR LIGHT-COLORED CONCRETE/DARK-STAINED CONCRETE. THE CONCRETE SURFACE SHALL BE SLIP RESISTANT.
6. DETECTABLE WARNING PANELS SHALL BE THE FULL WIDTH OF THE LANDING, BLENDED TRANSITION, OR CURB RAMP THEY ARE A PART OF AND SHALL BE A MINIMUM OF 2 FEET IN DEPTH. THE ROWS OF TRUNCATED DOMES SHALL BE ALIGNED PERPENDICULAR TO THE GRADE BREAK BETWEEN THE RAMP, BLENDED TRANSITION, OR LANDING AND THE STREET.

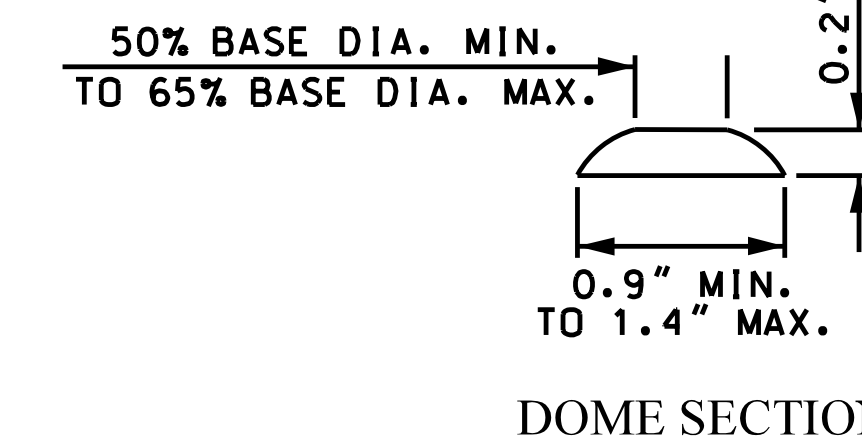
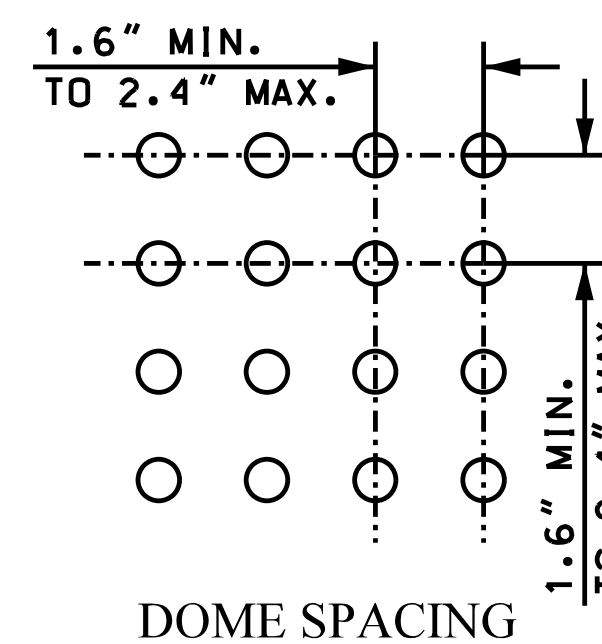

CITY OF PORTSMOUTH			
DEPARTMENT OF PUBLIC WORKS			
SIDEWALK CURB RAMPS WITH DETECTABLE WARNINGS			
FEDERAL PROJECT NO.	STATE PROJECT NO.	SHEET NO.	TOTAL SHEETS
	14493	14	91

EXISTING DETAIL	ARM	DATE	11/10
PROPOSED DESIGN	DEM	DATE	4/13
SHEET CHECKED	TAT	DATE	4/13
AS BUILT DETAILS		DATE	

NOTEBOOKS	BOOK	PAGE
	BOOK	PAGE
	BOOK	PAGE

REVISIONS AFTER PROPOSAL	NUMBER	DATE	STATION	DESCRIPTION

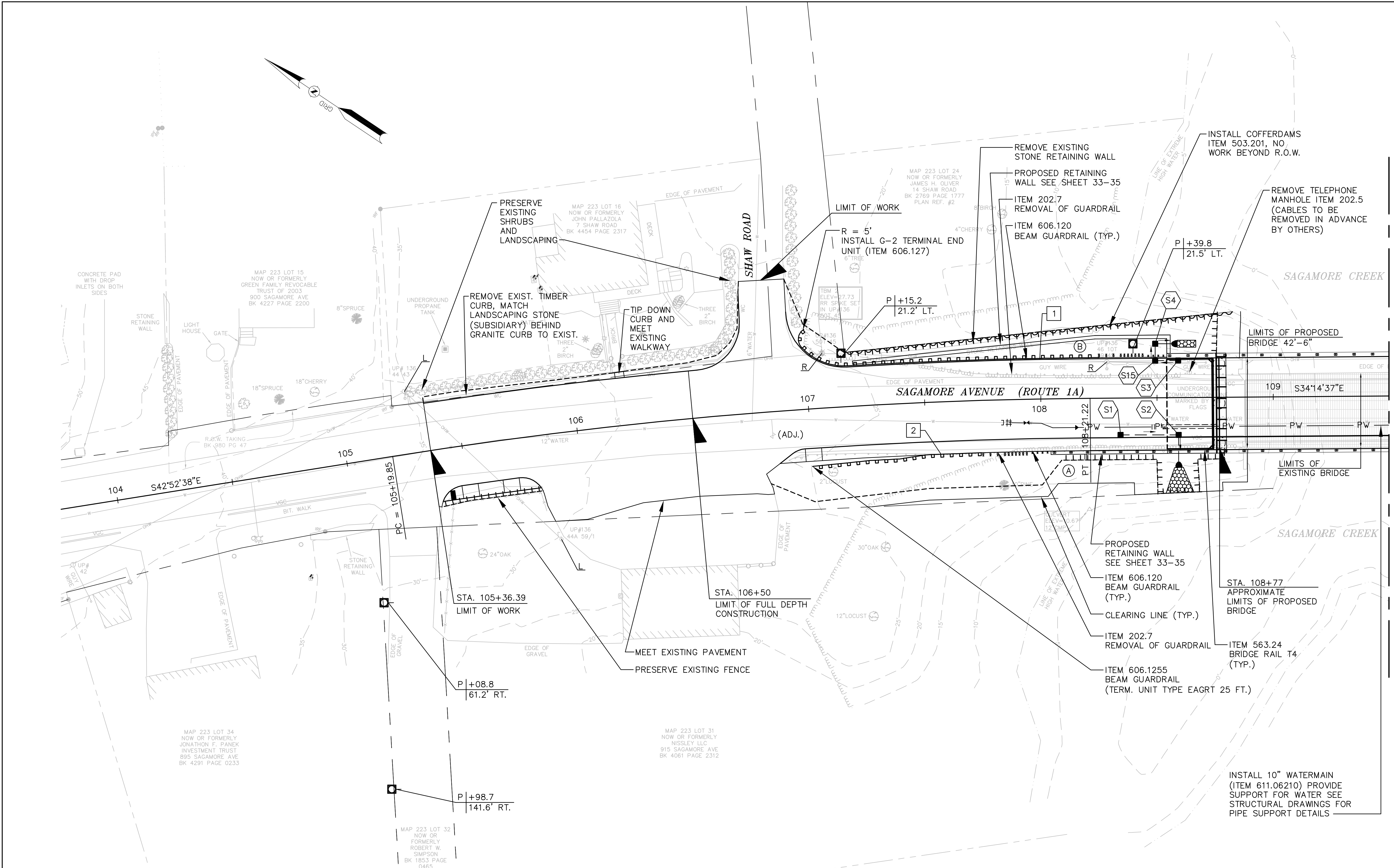

MATCH TO SHEET NO. 57

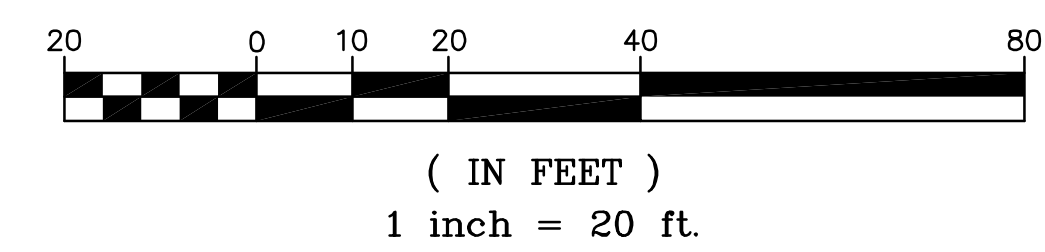

FAY, SPOFFORD & THORNDIKE, LLC

CITY OF PORTSMOUTH			
DEPARTMENT OF PUBLIC WORKS			
GENERAL PLANS			
FEDERAL PROJECT NO.	STATE PROJECT NO.	SHEET NO.	TOTAL SHEETS
X-A000(417)	14493	56	91

EXISTING DETAIL	ARM	DATE	11/10
PROPOSED DESIGN	DEM	DATE	4/13
SHEET CHECKED	TAT	DATE	4/13
AS BUILT DETAILS		DATE	

NOTEBOOKS	BOOK	PAGE
	BOOK	PAGE
	BOOK	PAGE

REVISIONS AFTER PROPOSAL	STATION	DESCRIPTION

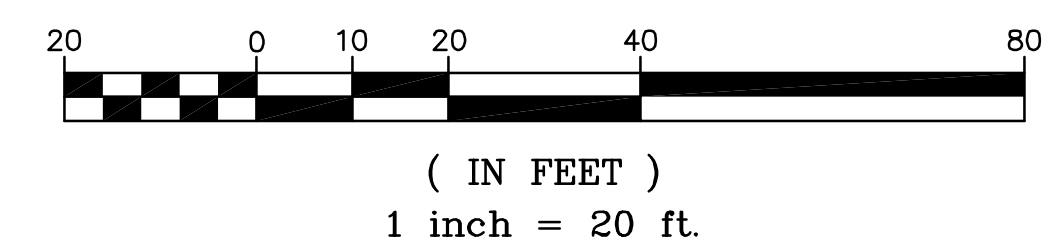
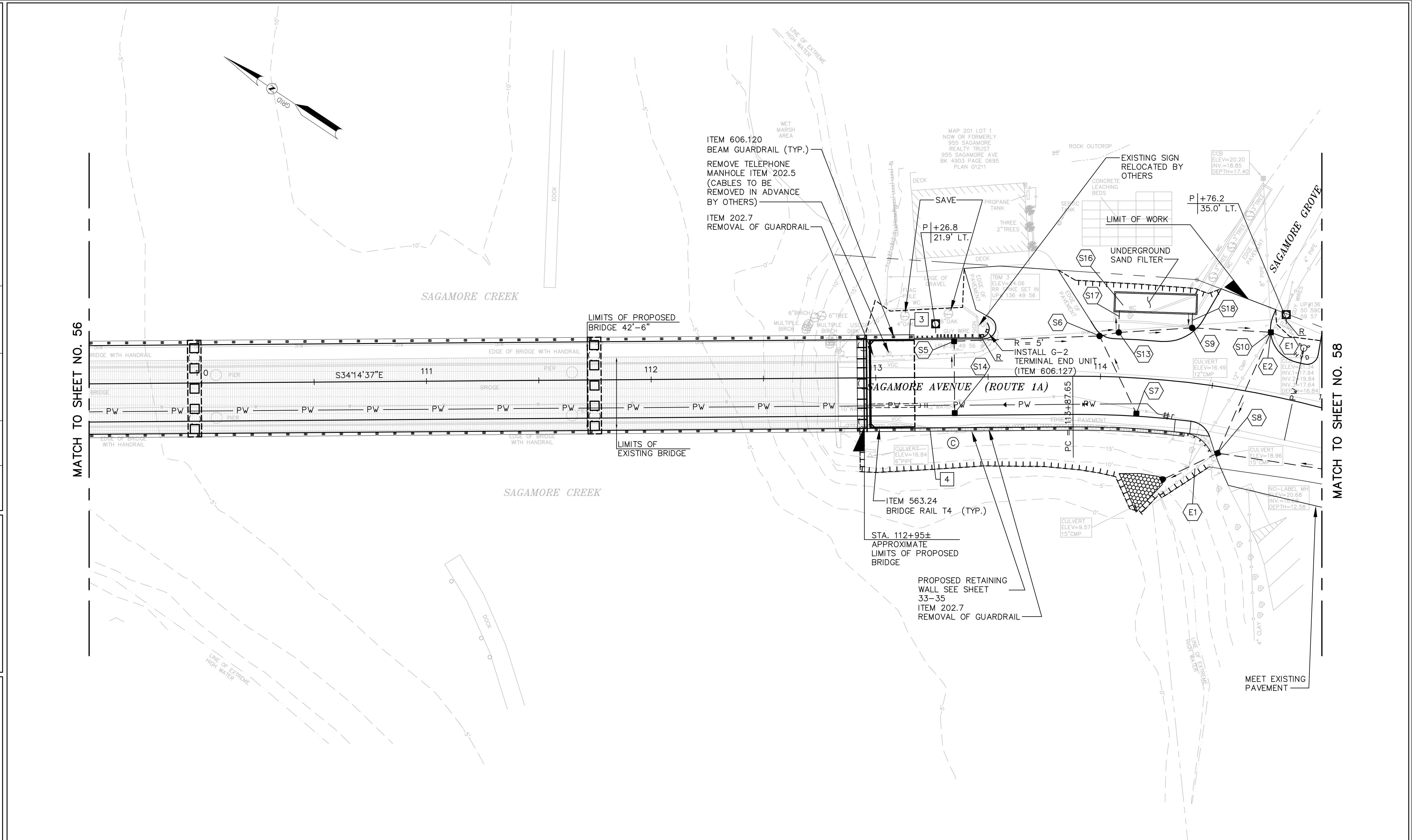

FAY, SPOFFORD & THORNDIKE, LLC

CITY OF PORTSMOUTH			
DEPARTMENT OF PUBLIC WORKS			
GENERAL PLANS			
FEDERAL PROJECT NO.	STATE PROJECT NO.	SHEET NO.	TOTAL SHEETS
X-A000(417)	14493	57	91

EXISTING DETAIL	ARM	DATE	11/10
PROPOSED DESIGN	DEM	DATE	4/13
SHEET CHECKED	TAT	DATE	4/13
AS BUILT DETAILS		DATE	

NOTEBOOKS	BOOK	PAGE
	BOOK	PAGE
	BOOK	PAGE

REVISIONS AFTER PROPOSAL	NUMBER	DATE	STATION	DESCRIPTION

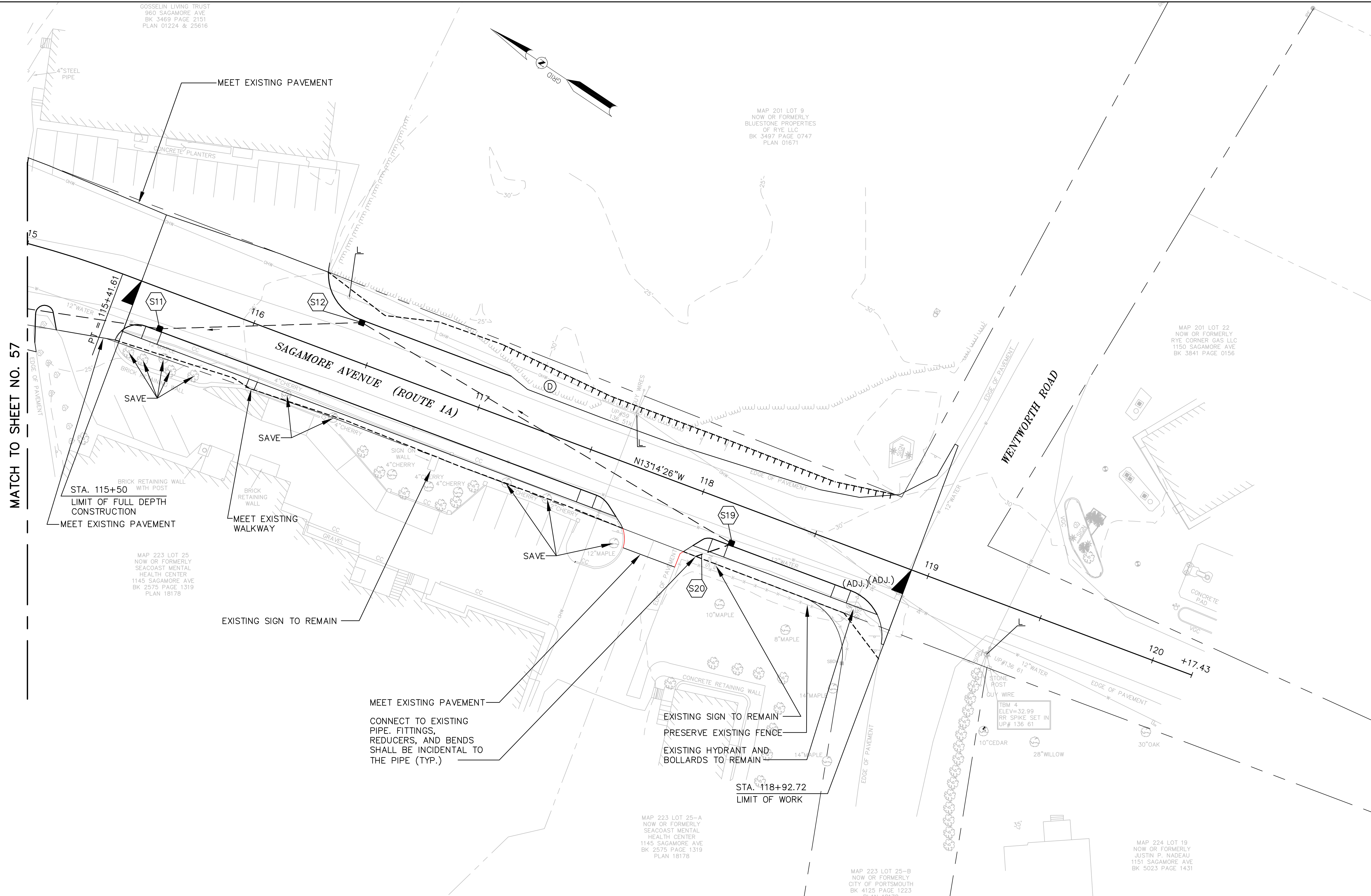

MATCH TO SHEET NO. 57

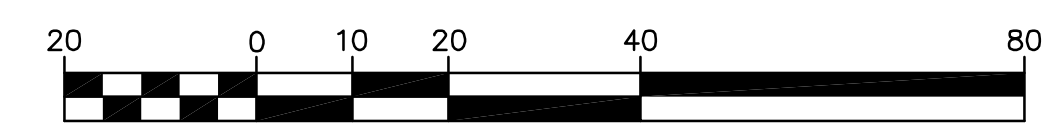

(IN FEET)
1 inch = 20 ft.

FAY, SPOFFORD & THORNDIKE, LLC

CITY OF PORTSMOUTH			
DEPARTMENT OF PUBLIC WORKS			
GENERAL PLANS			
FEDERAL PROJECT NO.	STATE PROJECT NO.	SHEET NO.	TOTAL SHEETS
X-A000(417)	14493	58	91

SAGAMORE AVE R

SAGAMORE AVE R

S1 STA 108+59.2, RT 16.0' TO STA 108+34.2, RT 16.0'
CONSTRUCT 21' x 15" RCP
CONSTRUCT CB-B @ +34.2, RT 16.0'
15" INV. OUT = 17.50
GRATE ELEV. = 23.9

S12 STA 115+64.0, RT 16.0' TO STA 116+42.0, LT 16.0'
CONSTRUCT 81' X 15" RCP
CONSTRUCT CB-B @+42.0, LT 16.0'
15" INV. OUT = 20.40
15" INV. IN = 20.65
GRATE ELEV. = 25.9

S2 STA 108+59.2, RT 28.0' TO STA 108+59.2, RT 16.0'
CONSTRUCT 10' x 15" PE PIPE (TYPE S)
CONSTRUCT 15" ALUMINIZED STEEL END SECTION @ +59.2, RT 28.0'
INV. @ PIPE = 16.47
CONSTRUCT CLASS C STONE STONE FILL AT PIPE OUTLET
(SEE DETAIL SHEET 11)
CONSTRUCT CB-B @ +59.2, RT 16.0'
15" INV. OUT = 16.65
15" INV. IN = 16.90
GRATE ELEV. = 23.9

S13 STA 114+38.2, LT 24.4' TO STA 114+07.4, LT 19.8'
CONSTRUCT 29' X 15" PE PIPE (TYPE S)
CONSTRUCT 5' DIA. FLOW CONTROL STRUCTURE @ +07.4, LT 19.8'
(SEE DETAIL SHEET NO. 11)
15" INV. OUT (S) = 15.25
6" INV. OUT (E) = 16.65
15" INV. IN (N) = 16.84
GRATE ELEV. = 22.7

S3 STA 108+49.3, LT 16.0' TO STA 108+59.2, LT 16.0'
CONSTRUCT 6' x 15" RCP
CONSTRUCT CB-B @ +59.2, LT 16.0'
15" INV. OUT = 18.36
GRATE ELEV. = 23.9

S14 STA 113+35.0, LT 16.0' TO STA 113+35.0, RT 16.0'
CONSTRUCT 28' X 15" RCP (3000D)
CONSTRUCT CB-B @ +35.0, RT 16.0'
15" INV. OUT = 17.92
GRATE ELEV. = 22.3

S4 STA 108+57.0, LT 23.1' TO STA 108+49.4, LT 23.3'
CONSTRUCT 6' x 15" PE PIPE (TYPE S)
CONSTRUCT 15" ALUMINIZED STEEL END SECTION @ +57.0, LT 23.1'
INV. @ PIPE = 17.50
CONSTRUCT CLASS C STONE STONE FILL AT PIPE OUTLET
(SEE DETAIL SHEET 11)
CONSTRUCT CB-B @ +49.4, LT 23.3'
15" INV. OUT = 17.66
15" INV. IN = 17.91
GRATE ELEV. = 23.0

S15 STA 108+49.4, LT 23.3' TO STA 108+49.3, LT 16.0'
CONSTRUCT 4' x 15" PE PIPE (TYPE S)
CONSTRUCT CB-B @ +49.3, LT 16.0'
15" INV. OUT = 17.99
15" INV. IN = 18.24
GRATE ELEV. = 23.9

S5 STA 114+07.5, LT 15.3' TO STA 113+35.0, LT 16.0'
CONSTRUCT 61' x 15" RCP (3000D)
CONSTRUCT CB-B @ +35.0, LT 16.0'
15" INV. OUT = 17.50
15" INV. IN = 17.75
GRATE ELEV. = 22.4

S16 CONSTRUCT UNDERGROUND SAND FILTER
(SEE DETAIL SHEET 11)

S6 STA 114+07.4, LT 19.8' TO STA 113+99.2, LT 18.0'
CONSTRUCT 4' x 15" PE PIPE (TYPE S)
CONSTRUCT 5' DIA. DMH @ +99.2, LT 18.0'
15" INV. OUT = 16.86
15" INV. IN (N) = 17.11
15" INV. IN (W) = 17.11
GRATE ELEV. = 22.3

S17 STA 114+07.3, LT 29.4' TO STA 114+07.4, LT 19.8'
CONSTRUCT 7' X 6" PE PIPE (TYPE S)

S18 STA 114+37.7, LT 30.8' TO STA 114+38.2, LT 24.4'
CONSTRUCT 4' X 12" PE PIPE (TYPE S)

S19 STA 116+42.0, LT 16.0' TO STA 118+18.5, RT 16.0'
CONSTRUCT 177' X 15" RCP
CONSTRUCT CB-B @ +18.5, RT 16.0'
15" INV. OUT = 21.54
6" INV. IN = 24.00
GRATE ELEV. = 29.6

S7 STA 113+99.2, LT 18.0' TO STA 114+17.0, RT 16.0'
CONSTRUCT 34' x 15" RCP (3000D)
CONSTRUCT CB-B @ +17.0, RT 16.0'
15" INV. OUT = 17.28
GRATE ELEV. = 21.6

S20 STA 118+18.5, RT 16.0' TO STA 118+6.6, RT 26.3'
CONSTRUCT 16' X 6" PE PIPE (TYPE S)
CONNECT TO EXISTING PLASTIC PIPE (SUBSIDIARY)

E1 STA 114+33.8, RT 49.2' TO STA 114+48.4, RT 36.7'
REMOVE 18' x 15" CMP
STA 114+48.4, RT 36.7' TO STA 114+53.8, RT 31.8'
REMOVE 7' x 15" CMP (SUBSIDIARY TO NOTE S8)

S8 STA 114+33.0, RT 43.0' TO STA 114+57.0, RT 29.4'
CONSTRUCT 21' X 15" PE PIPE (TYPE S)
CONSTRUCT 15" ALUMINIZED STEEL END SECTION @ +33.0, RT 43.0'
INV. @ PIPE = 10.00
CONSTRUCT CLASS C STONE FILL @ PIPE OUTLET
(SEE DETAIL SHEET 11)
CONSTRUCT CB-B @ +57.0, RT 29.4'
15" INV. OUT = 10.27
15" INV. IN (S) = 13.52
15" INV. IN (E) = 10.52
GRATE ELEV. = 19.9

E2 STA 114+44.2, RT 36.9' TO STA 114+67.0, LT 16.4'
REMOVE 58' x 12" CMP
STA 114+67.0, LT 16.4' TO STA 114+70.9, LT 27.6'
REMOVE 11' x 12" CMP (SUBSIDIARY TO NOTE S10)
REMOVE CB @ +70.9, LT 27.6' (SUBSIDIARY TO NOTE S10)

S9 STA 114+71.1, LT 27.7' TO STA 114+38.2, LT 24.4'
CONSTRUCT 31' X 15" RCP
CONSTRUCT DMH @ +38.2, LT 24.4'
15" INV. OUT = 11.21
15" INV. IN (W) = 15.05
15" INV. IN (E) = 11.46
GRATE ELEV. = 22.7

S10 STA 114+57.0, RT 29.4' TO STA 114+71.1, LT 27.7'
CONSTRUCT 55' X 15" RCP
CONSTRUCT 5' DIAMETER CB-B @ +71.1, LT 27.7'
15" INV. OUT = 10.80
15" INV. IN = 11.05
EXIST 8" INV. IN = 17.94
EXIST 4" INV. IN = 19.84
GRATE ELEV. = 22.3

S11 STA 114+57.0, RT 29.4' TO STA 115+64.0, RT 16.0'
CONSTRUCT 98' X 15" RCP
CONSTRUCT CB-B @ +64, RT 16.0'
15" INV. OUT = 18.14
15" INV. IN = 18.39
12" INV. IN = 18.39
GRATE ELEV. = 23.8

NOTES:

- ALL CATCH BASIN SUMP DEPTHS TO BE FOUR TIMES THE DIAMETER OF THE CATCH BASIN OUTLET PIPE.

EXISTING DETAIL	ARM	DATE	11/10
	DEM	DATE	4/13
PROPOSED DESIGN	DEM	DATE	4/13
	TAT	DATE	4/13
SHEET CHECKED	TAT	DATE	
		DATE	
AS BUILT DETAILS			

REVISIONS AFTER PROPOSAL	NUMBER	DATE	STATION	DESCRIPTION

NOTEBOOKS	BOOK	PAGE

CITY OF PORTSMOUTH			
DEPARTMENT OF PUBLIC WORKS			
DRAINAGE NOTES			
FEDERAL PROJECT NO.	STATE PROJECT NO.	SHEET NO.	TOTAL SHEETS
X-A000(417)	14493	59	91

EXISTING DETAIL	ARM	DATE	11/10	REVISIONS AFTER PROPOSAL	STATION	DESCRIPTION
PROPOSED DESIGN	DEM	DATE	4/13			
SHEET CHECKED	TAT	DATE	4/13			
AS BUILT DETAILS		DATE				

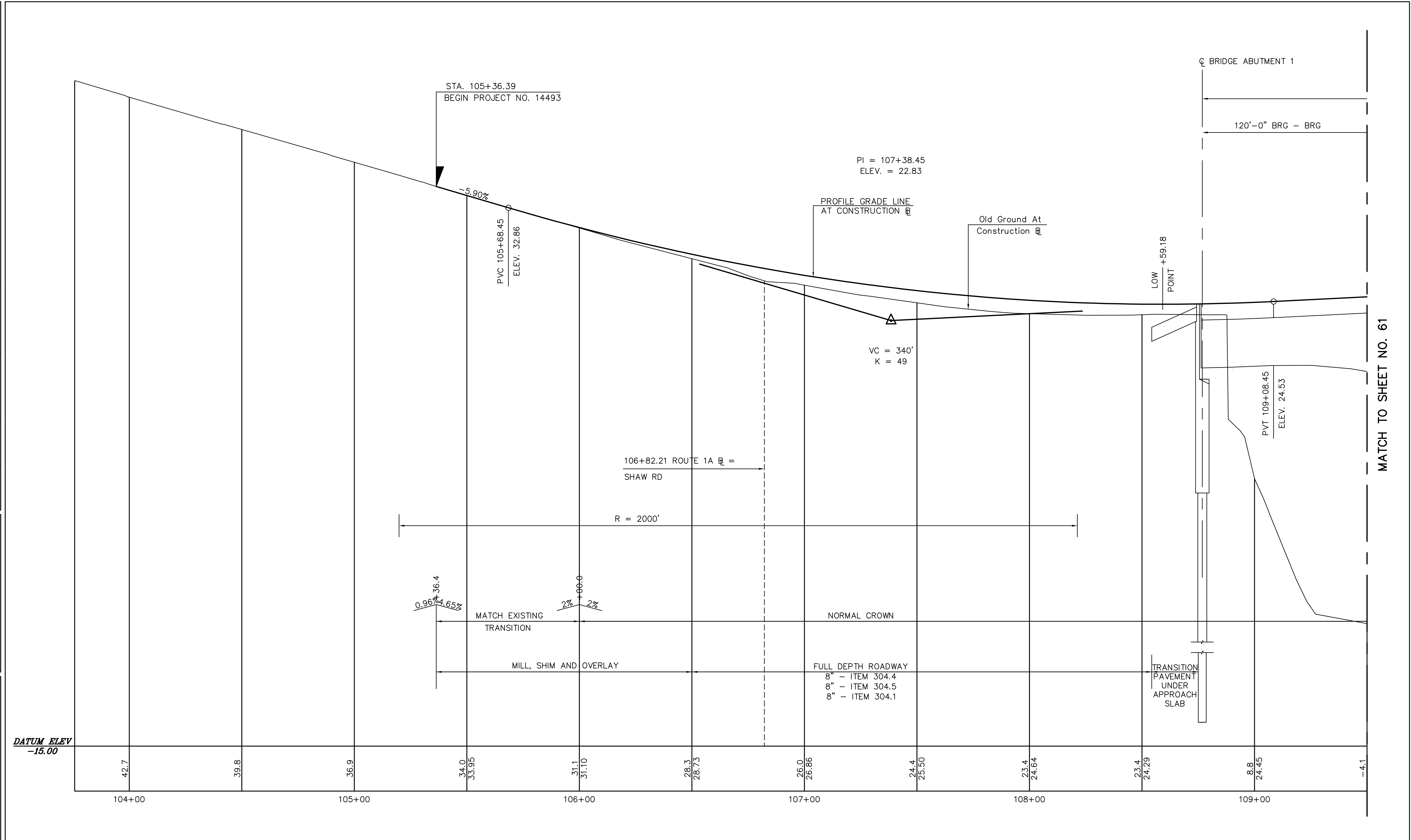

MATCH TO SHEET NO. 61

SCALE: HORIZ. 1"=20FT.
VERT. 1"=4FT.

FAY, SPOFFORD & THORNDIKE, LLC

CITY OF PORTSMOUTH			
DEPARTMENT OF PUBLIC WORKS			
SAGAMORE AVENUE			
PROFILE			
FEDERAL PROJECT NO.	STATE PROJECT NO.	SHEET NO.	TOTAL SHEETS
X-A000(417)	14493	60	91

EXISTING DETAIL	ARM	DATE	11/10
PROPOSED DESIGN	DEM	DATE	4/13
SHEET CHECKED	TAT	DATE	4/13
AS BUILT DETAILS		DATE	

NUMBER	DATE	STATION	DESCRIPTION

NOTEBOOKS	BOOK	PAGE

MATCH TO SHEET NO. 60

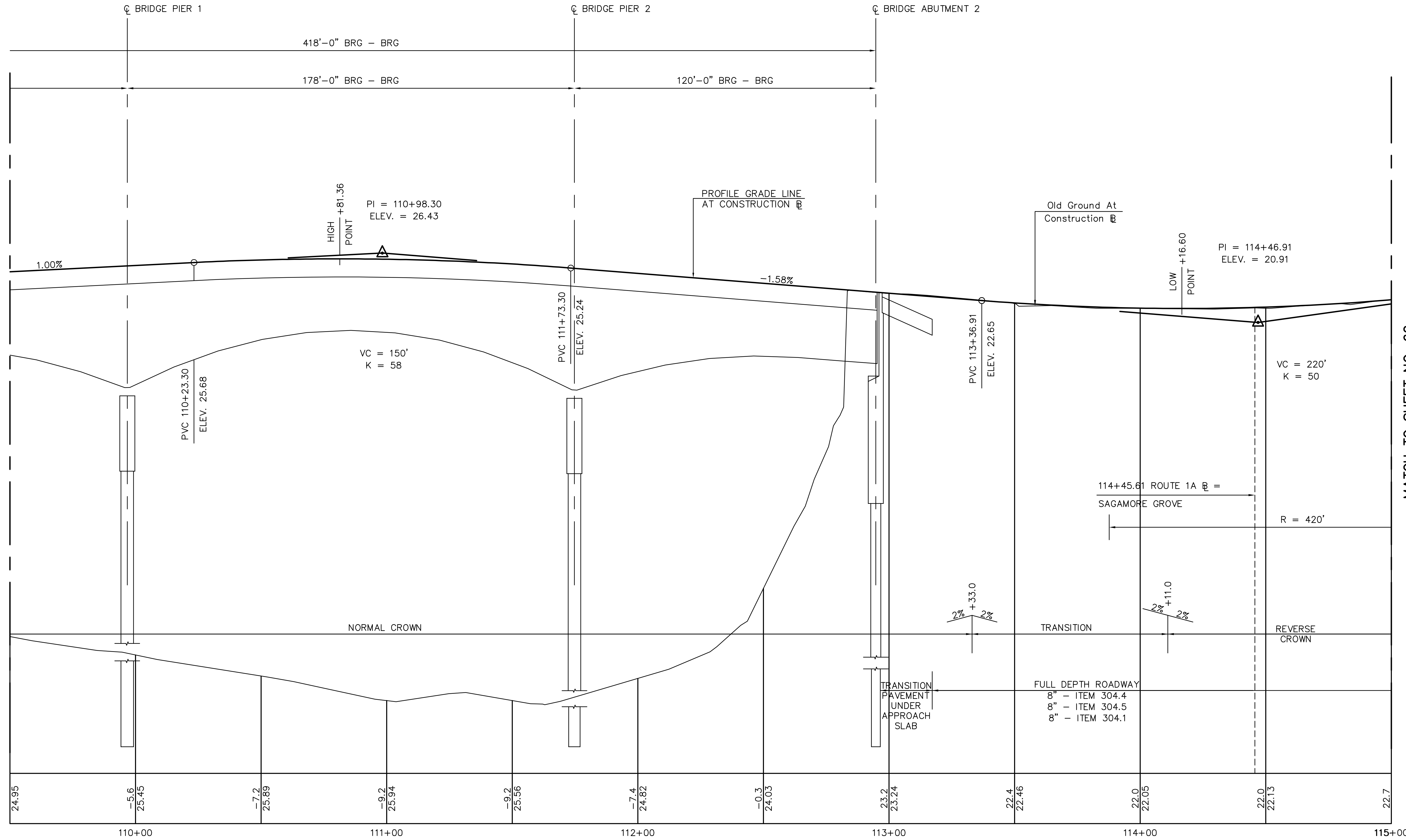

MATCH TO SHEET NO. 62

SCALE: HORIZ. 1"=20FT.
VERT. 1"=4FT.

FAY, SPOFFORD & THORNDIKE, LLC

CITY OF PORTSMOUTH			
DEPARTMENT OF PUBLIC WORKS			
SAGAMORE AVENUE			
PROFILE			
FEDERAL PROJECT NO.	STATE PROJECT NO.	SHEET NO.	TOTAL SHEETS
X-A000(417)	14493	61	91

EXISTING DETAIL	ARM	DATE	11/10	REVISIONS AFTER PROPOSAL	NUMBER	DATE	STATION	DESCRIPTION
PROPOSED DESIGN	DEM	DATE	4/13					
SHEET CHECKED	TAT	DATE	4/13					
AS BUILT DETAILS		DATE						

MATCH TO SHEET NO. 61

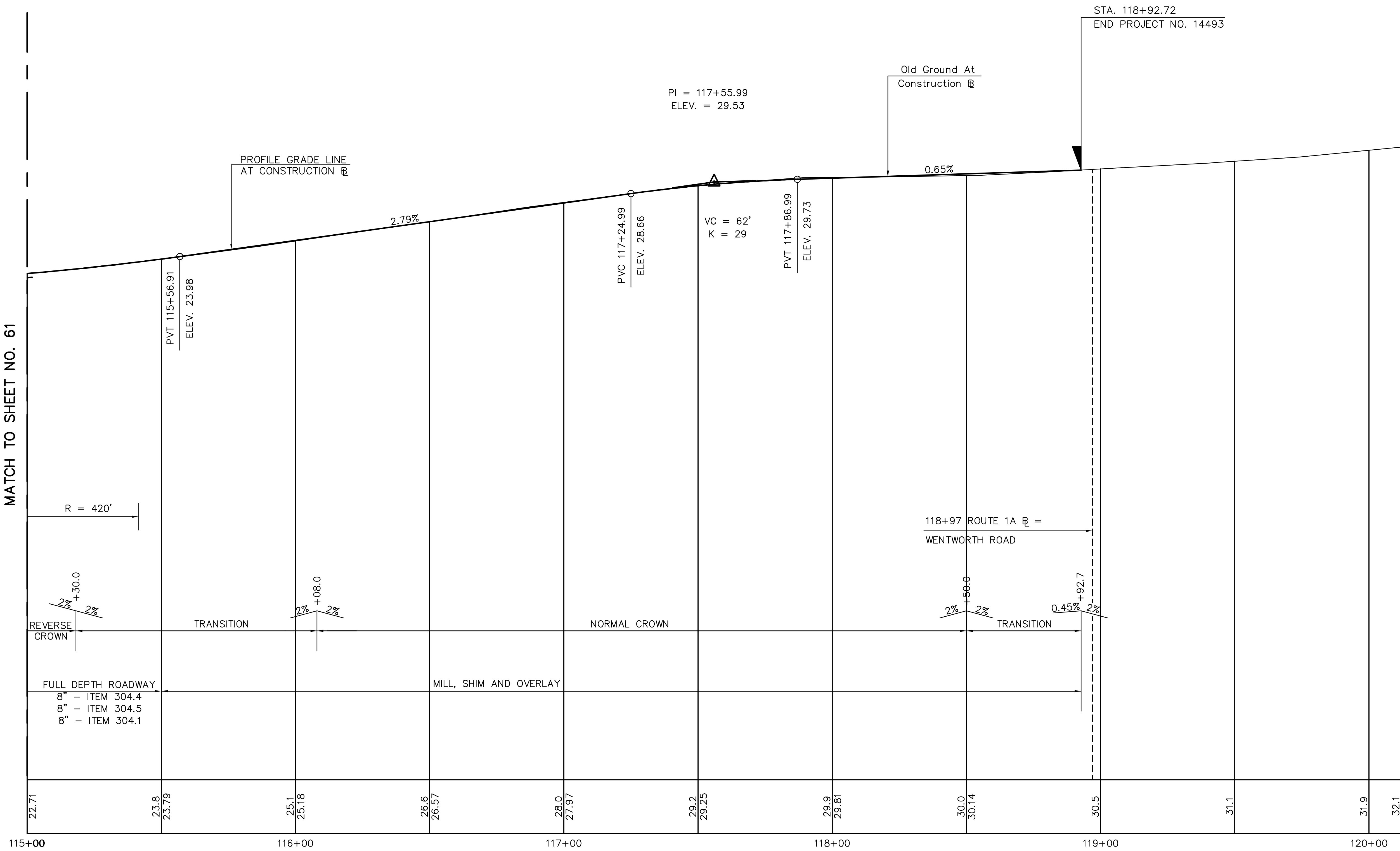

SCALE: HORIZ. 1"=20FT.
VERT. 1"=4FT.

FAY, SPOFFORD & THORNDIKE, LLC

CITY OF PORTSMOUTH			
DEPARTMENT OF PUBLIC WORKS			
SAGAMORE AVENUE PROFILE			
FEDERAL PROJECT NO.	STATE PROJECT NO.	SHEET NO.	TOTAL SHEETS
X-A000(417)	14493	62	91

REVISIONS AFTER PROPOSAL		STATION	DESCRIPTION
NUMBER	DATE	STATION	DESCRIPTION

NOTEBOOKS	
BOOK	PAGE
BOOK	PAGE
BOOK	PAGE

EXISTING DETAIL	ARM	DATE	11/10
PROPOSED DESIGN	DEM	DATE	4/13
SHEET CHECKED	TAT	DATE	4/13
AS BUILT DETAILS		DATE	

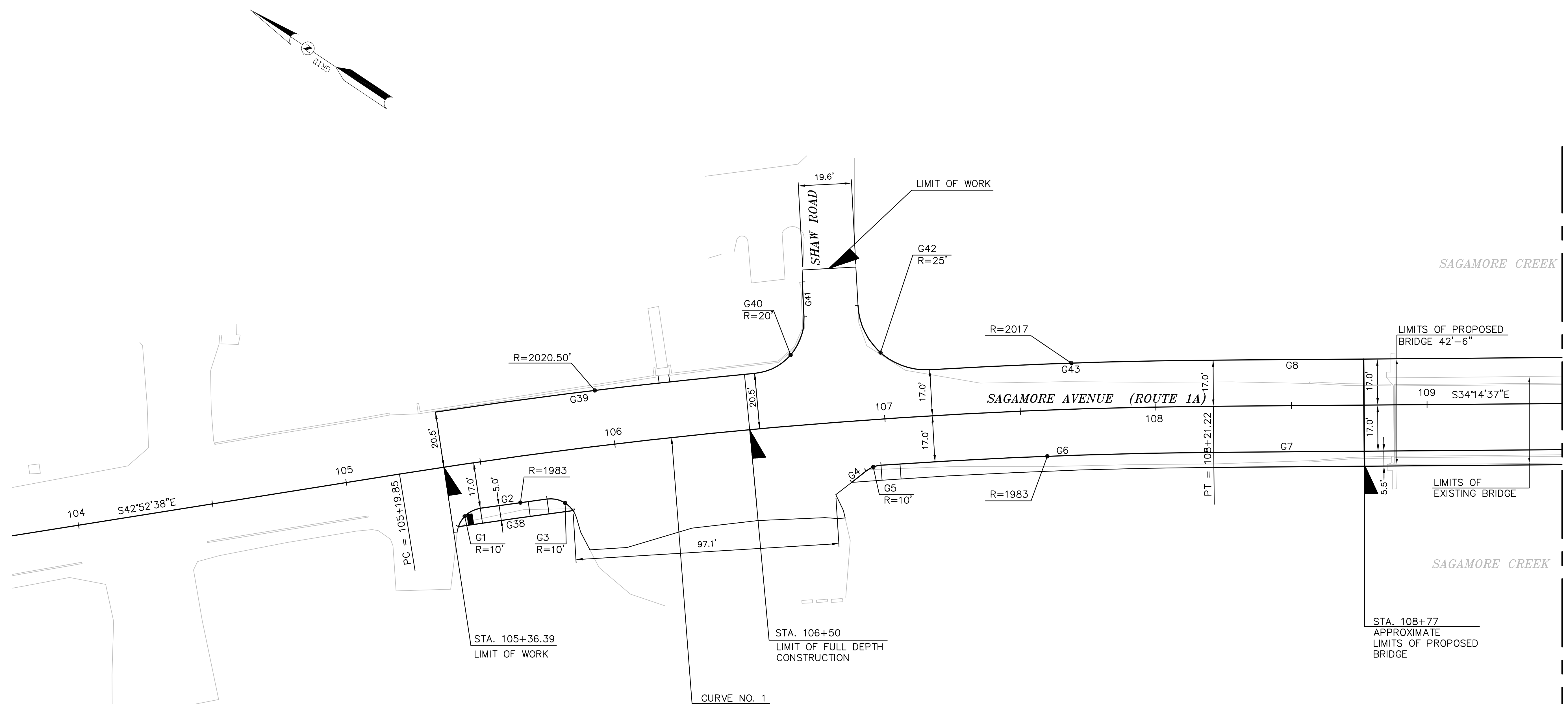

CURVE NO. 1
 PI = 106+70.82
 N = 203860.42
 E = 1229276.08
 Δ = 08°-38'-01" RT.
 D = 02°-51'-53"
 T = 150.97 FT
 R = 2000.00 FT
 L = 301.37 FT
 E = 5.69 FT

LEFT	STA	RIGHT
-0.96%	105+36.39	-4.65%
-2.00%	106+00.00	-2.00%
-2.00%	113+33.00	-2.00%
-1.13%	113+50.00	-2.00%
0%	113+72.00	-2.00%
0.14%	113+75.00	-2.00%
2.00%	114+00.00	-2.00%
2.00%	114+50.00	-2.00%
2.00%	115+00.00	-2.00%

LEFT	STA	RIGHT
2.00%	115+30.00	-2.00%
0.98%	115+50.00	-2.00%
0.00%	115+69.00	-2.00%
-1.60%	116+00.00	-2.00%
-2.00%	116+08.00	-2.00%
-2.00%	118+50.00	-2.00%
-0.45%	118+92.72	-2.00%

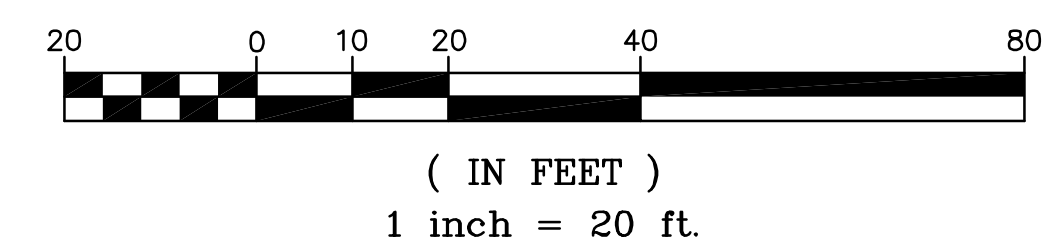

FAY, SPOFFORD & THORNDIKE, LLC

CITY OF PORTSMOUTH			
DEPARTMENT OF PUBLIC WORKS			
CURBING AND ALIGNMENT PLANS			
FEDERAL PROJECT NO.	STATE PROJECT NO.	SHEET NO.	TOTAL SHEETS
X-A000(417)	14493	63	91

MATCH TO SHEET NO. 64

EXISTING DETAIL	ARM	DATE	11/10
PROPOSED DESIGN	DEM	DATE	4/13
SHEET CHECKED	TAT	DATE	4/13
AS BUILT DETAILS		DATE	

NUMBER	DATE	STATION	DESCRIPTION

NOTEBOOKS	BOOK	PAGE

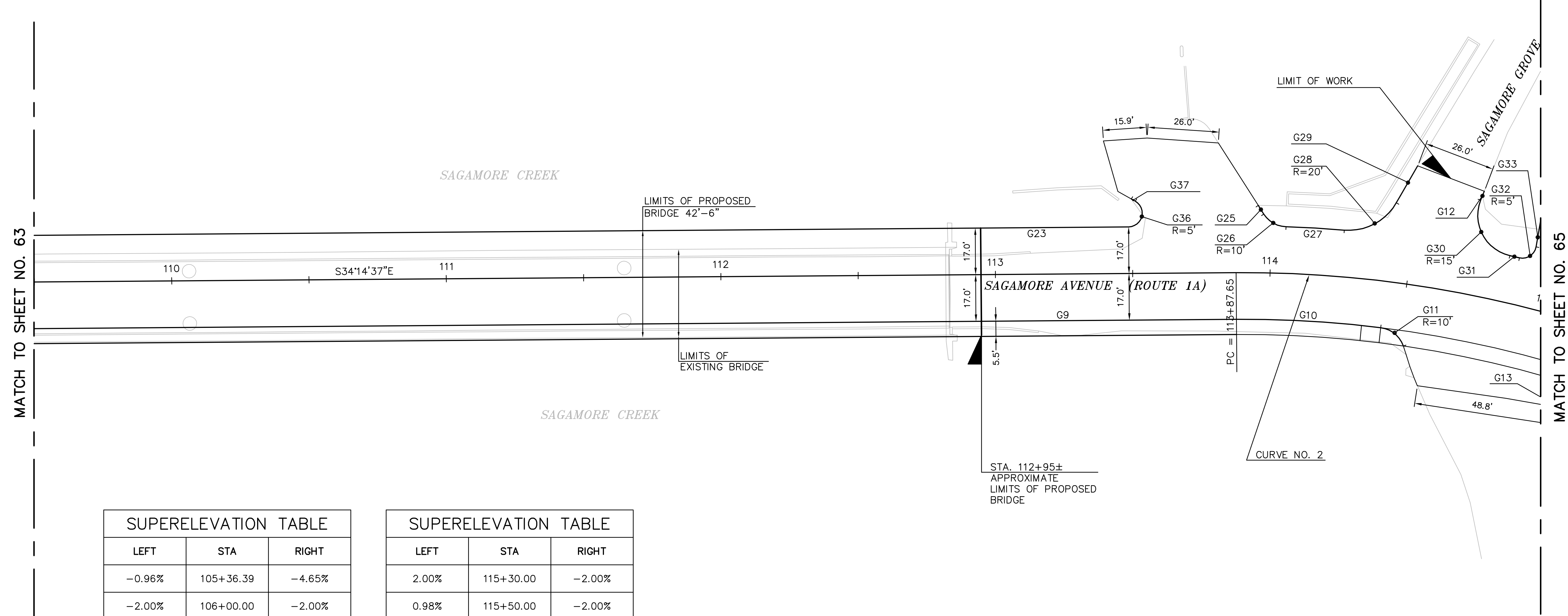
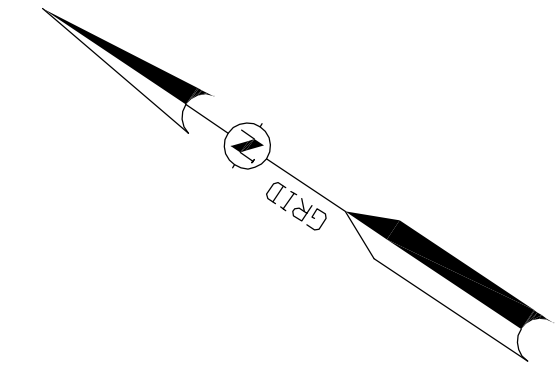

SUPERELEVATION TABLE

LEFT	STA	RIGHT
-0.96%	105+36.39	-4.65%
-2.00%	106+00.00	-2.00%
-2.00%	113+33.00	-2.00%
-1.13%	113+50.00	-2.00%
0%	113+72.00	-2.00%
0.14%	113+75.00	-2.00%
2.00%	114+00.00	-2.00%
2.00%	114+50.00	-2.00%
2.00%	115+00.00	-2.00%

SUPERELEVATION TABLE

LEFT	STA	RIGHT
2.00%	115+30.00	-2.00%
0.98%	115+50.00	-2.00%
0.00%	115+69.00	-2.00%
-1.60%	116+00.00	-2.00%
-2.00%	116+08.00	-2.00%
-2.00%	118+50.00	-2.00%
-0.45%	118+92.72	-2.00%

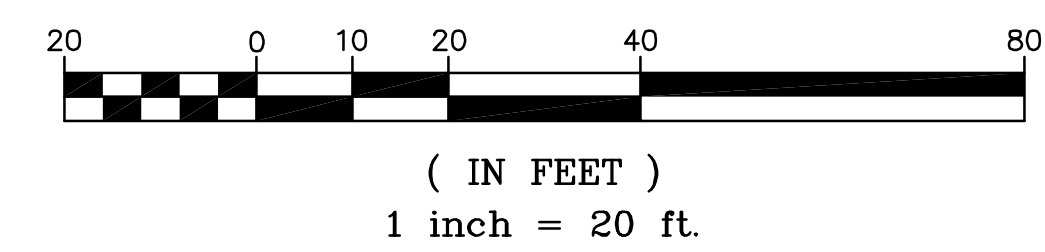

CURVE NO. 2
 PI = 114+65.50
 N = 203203.02
 E = 1229723.58
 $\Delta = 21^\circ-00'-11''$ RT.
 D = 13'-38'-31"
 T = 77.85 FT
 R = 420.00 FT
 L = 153.96 FT
 E = 7.15 FT

FAY, SPOFFORD & THORNDIKE, LLC

CITY OF PORTSMOUTH			
DEPARTMENT OF PUBLIC WORKS			
CURBING AND ALIGNMENT PLANS			
FEDERAL PROJECT NO.	STATE PROJECT NO.	SHEET NO.	TOTAL SHEETS
X-A000(417)	14493	64	91

MATCH TO SHEET NO. 63

MATCH TO SHEET NO. 65

CURVE NO. 2
 PI = 114+65.50
 N = 203203.02
 E = 1229723.58
 $\Delta = 21^\circ-00'-11''$ RT.
 D = 13'-38'-31"
 T = 77.85 FT
 R = 420.00 FT
 L = 153.96 FT
 E = 7.15 FT

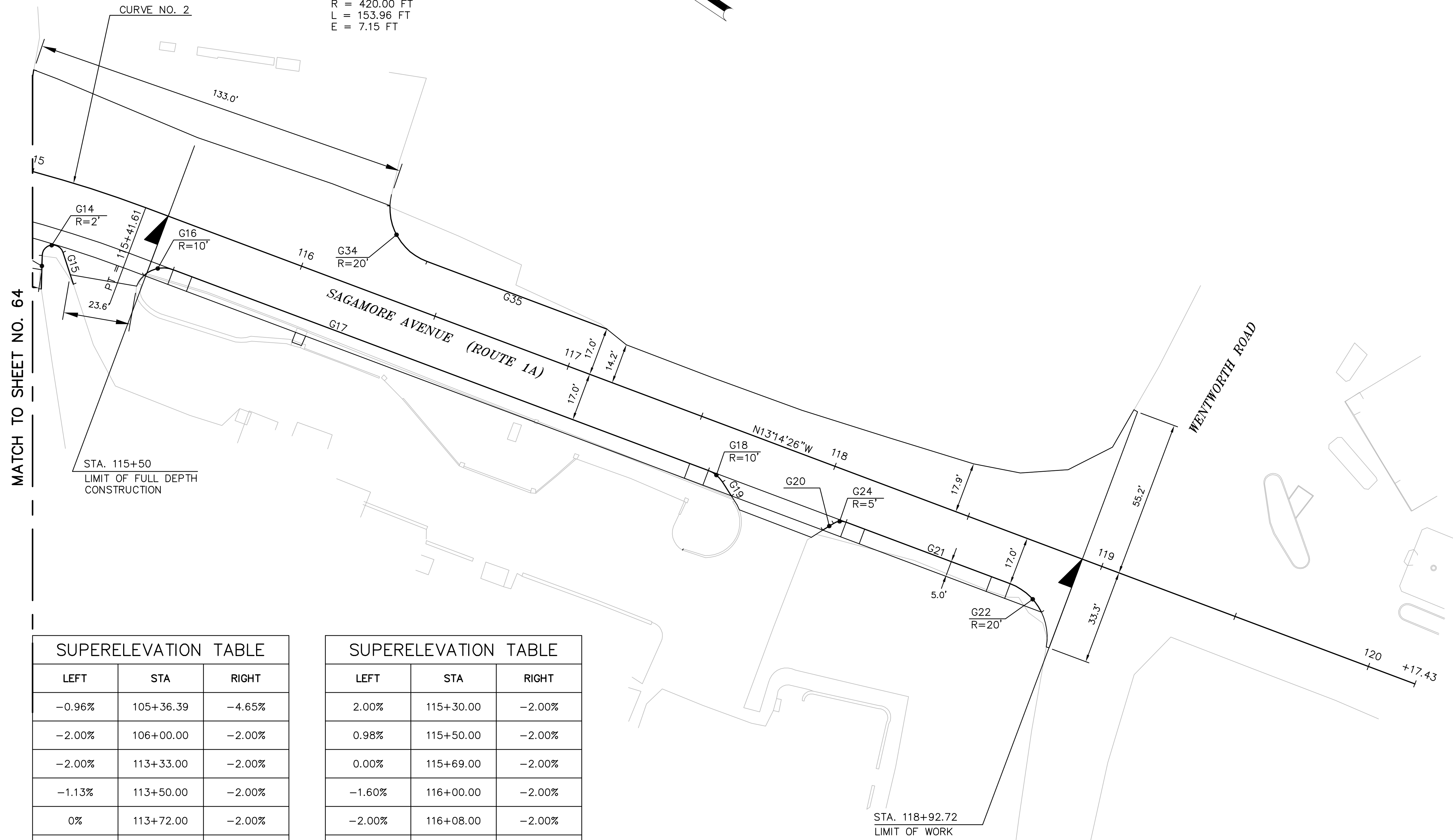
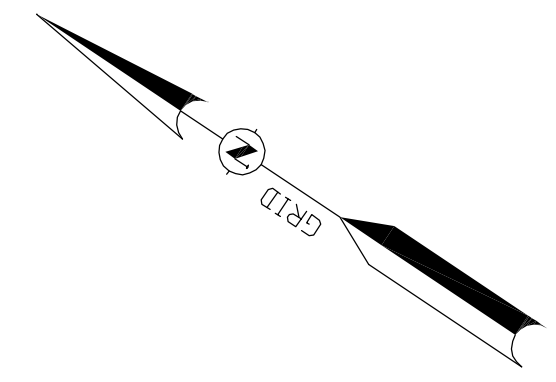

STA. 115+50
 LIMIT OF FULL DEPTH
 CONSTRUCTION

STA. 118+92.72
 LIMIT OF WORK

SUPERELEVATION TABLE

LEFT	STA	RIGHT
-0.96%	105+36.39	-4.65%
-2.00%	106+00.00	-2.00%
-2.00%	113+33.00	-2.00%
-1.13%	113+50.00	-2.00%
0%	113+72.00	-2.00%
0.14%	113+75.00	-2.00%
2.00%	114+00.00	-2.00%
2.00%	114+50.00	-2.00%
2.00%	115+00.00	-2.00%

SUPERELEVATION TABLE

LEFT	STA	RIGHT
2.00%	115+30.00	-2.00%
0.98%	115+50.00	-2.00%
0.00%	115+69.00	-2.00%
-1.60%	116+00.00	-2.00%
-2.00%	116+08.00	-2.00%
-2.00%	118+50.00	-2.00%
-0.45%	118+92.72	-2.00%



(IN FEET)
 1 inch = 20 ft.

FAY, SPOFFORD & THORNDIKE, LLC

CITY OF PORTSMOUTH
 DEPARTMENT OF PUBLIC WORKS

CURBING AND ALIGNMENT PLANS

FEDERAL PROJECT NO.	STATE PROJECT NO.	SHEET NO.	TOTAL SHEETS
X-A000(417)	14493	65	91

EXISTING DETAIL		ARM		DATE		11/10	
PROPOSED DESIGN	DEM	DATE	4/13	DATE	4/13	DATE	4/13
SHEET CHECKED	TAT	DATE	4/13	DATE	4/13	DATE	4/13
AS BUILT DETAILS		DATE		DATE		DATE	

NOTEBOOKS		REVISIONS AFTER PROPOSAL	
BOOK	PAGE	STATION	DESCRIPTION
BOOK	PAGE		
BOOK	PAGE		

REVISIONS AFTER PROPOSAL		STATION	DESCRIPTION
NUMBER	DATE	STATION	

NOTEBOOKS	
BOOK	PAGE
BOOK	PAGE
BOOK	PAGE

EXISTING DETAIL	ARM	DATE	11/10
PROPOSED DESIGN	DEM	DATE	4/13
SHEET CHECKED	TAT	DATE	4/13
AS BUILT DETAILS		DATE	

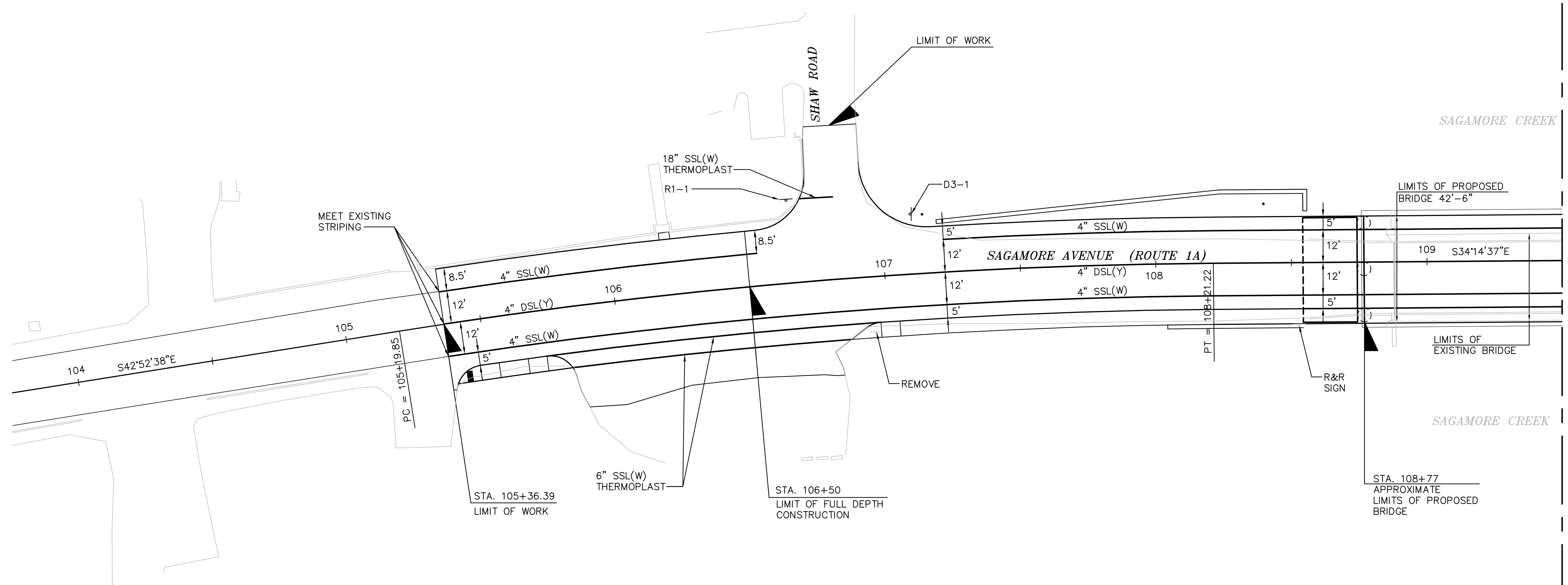
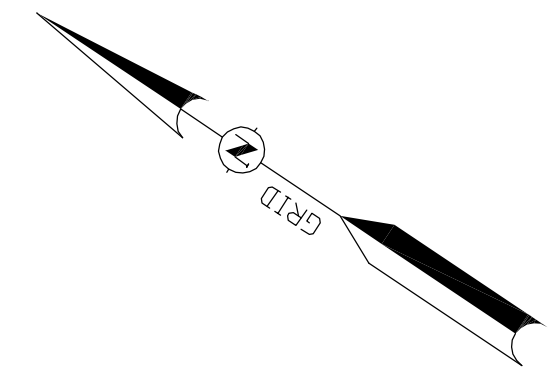

LEGEND:

DSL (Y) DOUBLE SOLID LINE (YELLOW)
 SSL (W) SINGLE SOLID LINE (WHITE)
 R&R REMOVE AND RESET

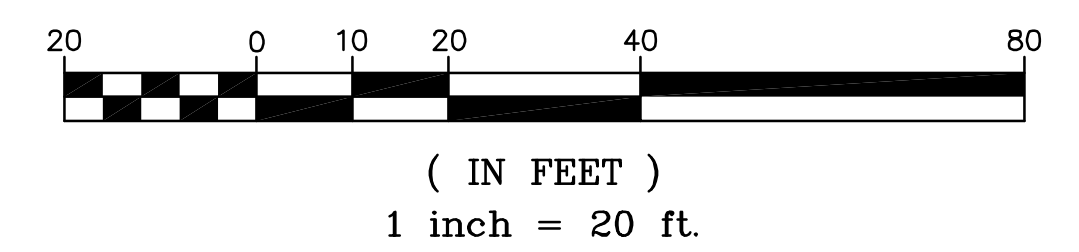

FAY, SPOFFORD & THORNDIKE, LLC

MATCH TO SHEET NO. 67

CITY OF PORTSMOUTH			
DEPARTMENT OF PUBLIC WORKS			
PAVEMENT MARKING AND SIGNAGE PLAN			
FEDERAL PROJECT NO.	STATE PROJECT NO.	SHEET NO.	TOTAL SHEETS
X-A000(417)	14493	66	91

REVISIONS AFTER PROPOSAL		STATION	DESCRIPTION
NUMBER	DATE	STATION	

NOTEBOOKS		BOOK	PAGE
BOOK	PAGE		

EXISTING DETAIL	ARM	DATE	11/10
PROPOSED DESIGN	DEM	DATE	4/13
SHEET CHECKED	TAT	DATE	4/13
AS BUILT DETAILS		DATE	

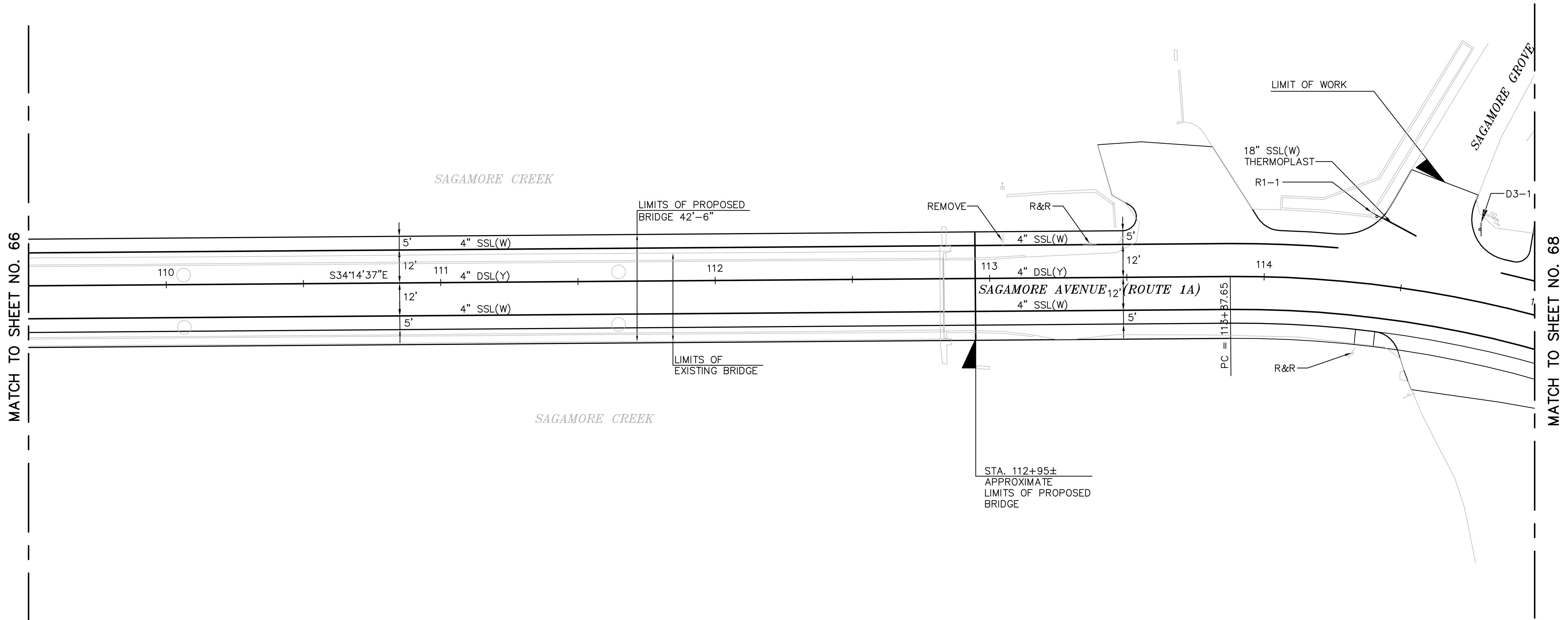
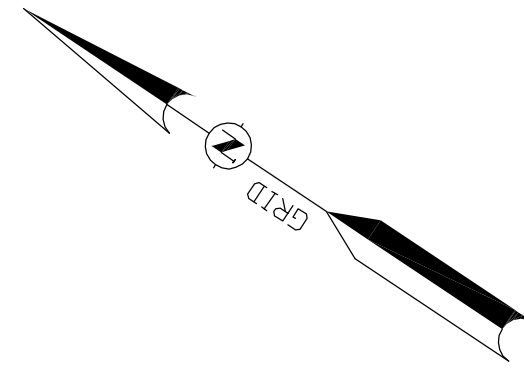

LEGEND:

SSL (W) SINGLE SOLID LINE (WHITE)
 DSL (Y) DOUBLE SOLID LINE (YELLOW)
 R&R REMOVE AND RESET

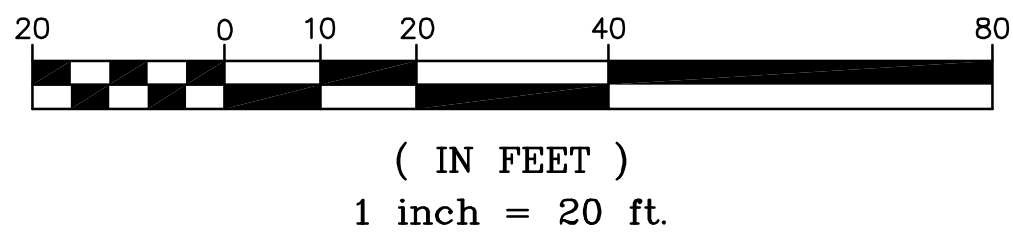

FAY, SPOFFORD & THORNDIKE, LLC

CITY OF PORTSMOUTH			
DEPARTMENT OF PUBLIC WORKS			
PAVEMENT MARKING AND SIGNAGE PLAN			
FEDERAL PROJECT NO.	STATE PROJECT NO.	SHEET NO.	TOTAL SHEETS
X-A000(417)	14493	67	91

EXISTING DETAIL	ARM	DATE	11/10
PROPOSED DESIGN	DEM	DATE	4/13
SHEET CHECKED	TAT	DATE	4/13
AS BUILT DETAILS		DATE	

NOTEBOOKS	BOOK	PAGE
	BOOK	PAGE
	BOOK	PAGE

REVISIONS AFTER PROPOSAL	NUMBER	DATE	STATION	DESCRIPTION

MATCH TO SHEET NO. 67

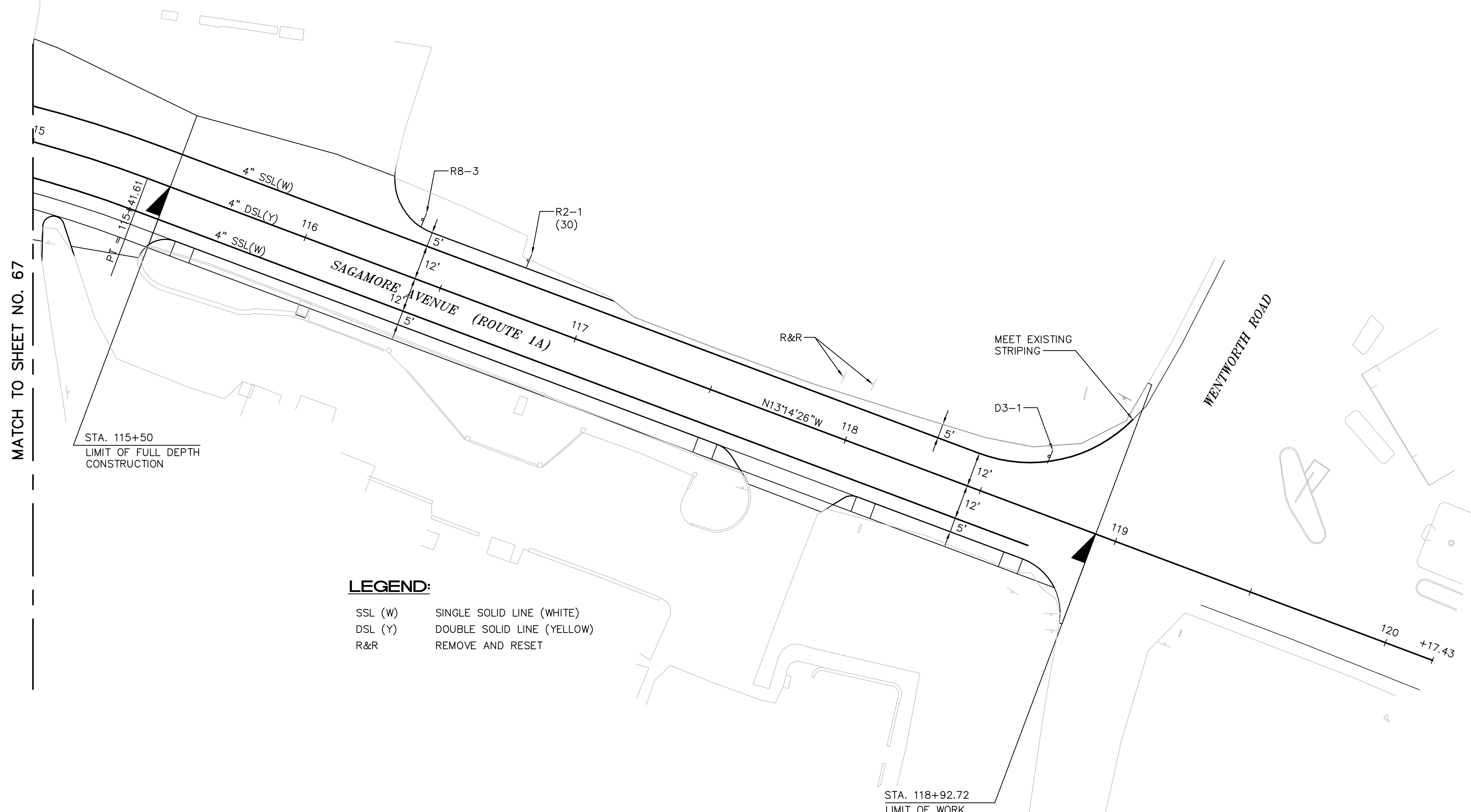
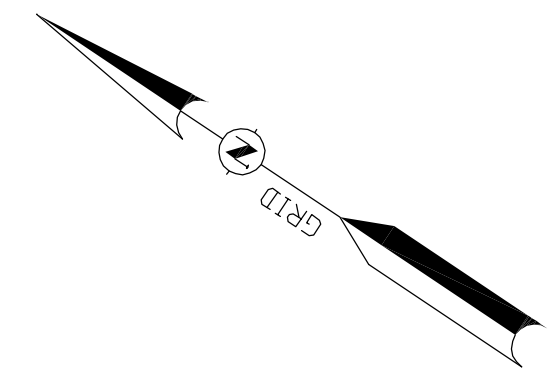

LEGEND:
 SSL (W) SINGLE SOLID LINE (WHITE)
 DSL (Y) DOUBLE SOLID LINE (YELLOW)
 R&R REMOVE AND RESET

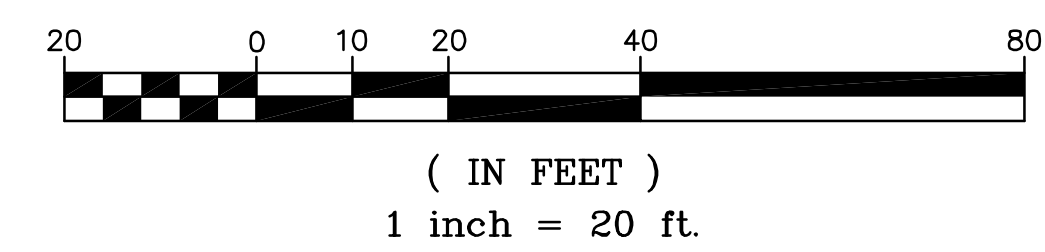

FAY, SPOFFORD & THORNDIKE, LLC

CITY OF PORTSMOUTH			
DEPARTMENT OF PUBLIC WORKS			
PAVEMENT MARKING AND SIGNAGE PLAN			
FEDERAL PROJECT NO.	STATE PROJECT NO.	SHEET NO.	TOTAL SHEETS
X-A000(417)	14493	68	91

EXISTING DETAIL	ARM	DATE	11/10
PROPOSED DESIGN	DEM	DATE	4/13
SHEET CHECKED	TAT	DATE	4/13
AS BUILT DETAILS		DATE	

REVISIONS AFTER PROPOSAL	STATION	DESCRIPTION

NOTEBOOKS	PAGE
BOOK	PAGE
BOOK	PAGE

NUMBER	DATE	STATION

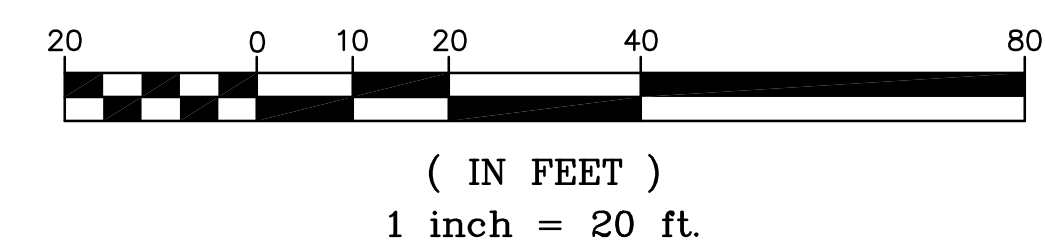
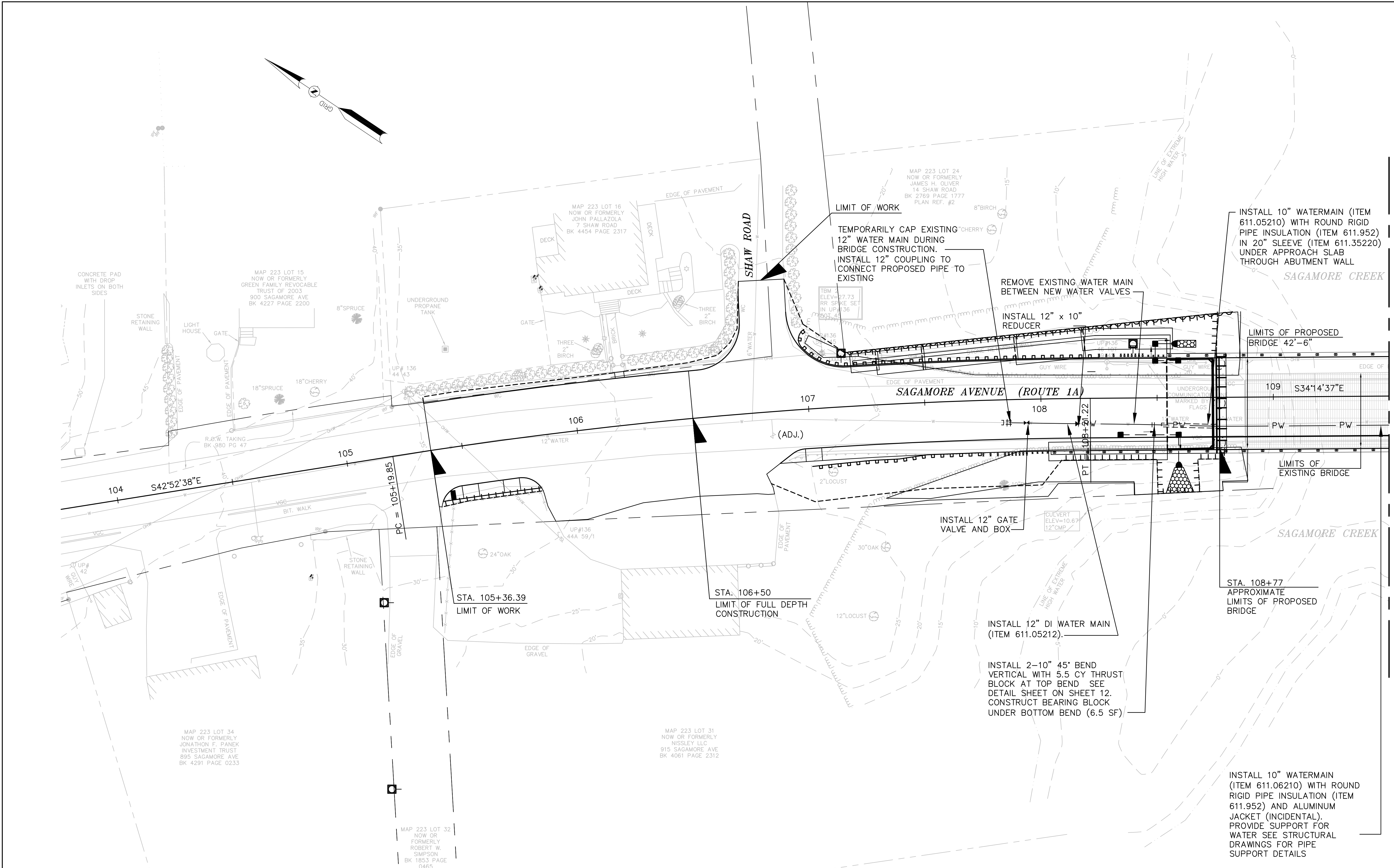

FAY, SPOFFORD & THORNDIKE, LLC

CITY OF PORTSMOUTH			
DEPARTMENT OF PUBLIC WORKS			
WATER MAIN REPLACEMENT PLAN			
FEDERAL PROJECT NO.	STATE PROJECT NO.	SHEET NO.	TOTAL SHEETS
X-A000(417)	14493	69	91

MATCH TO SHEET NO. 70

EXISTING DETAIL	ARM	DATE	11/10
PROPOSED DESIGN	DEM	DATE	4/13
SHEET CHECKED	TAT	DATE	4/13
AS BUILT DETAILS		DATE	

NOTEBOOKS	BOOK	PAGE
	BOOK	PAGE
	BOOK	PAGE

REVISIONS AFTER PROPOSAL	NUMBER	DATE	STATION	DESCRIPTION

MATCH TO SHEET NO. 69

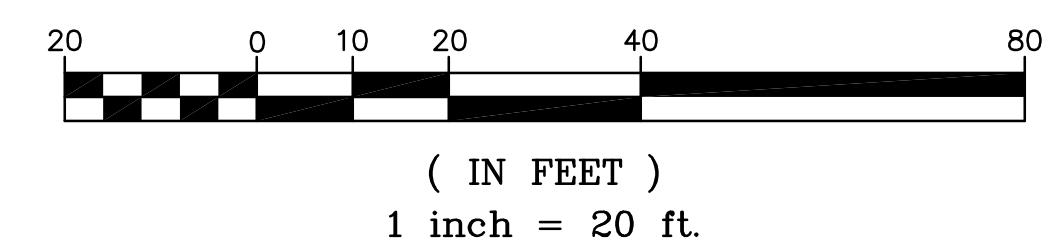
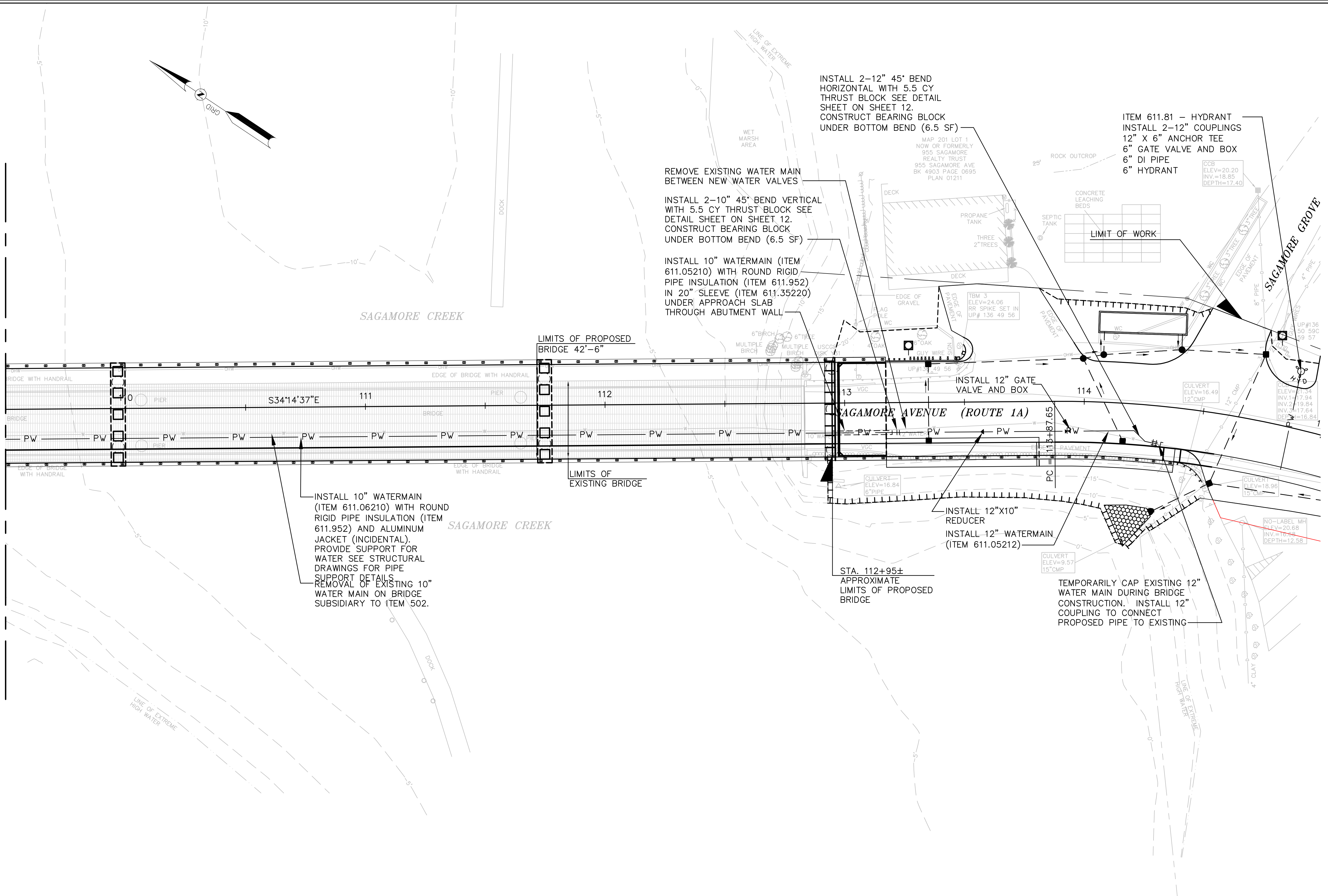

CITY OF PORTSMOUTH			
DEPARTMENT OF PUBLIC WORKS			
WATER MAIN REPLACEMENT PLAN			
FEDERAL PROJECT NO.	STATE PROJECT NO.	SHEET NO.	TOTAL SHEETS
X-A000(417)	14493	70	91

FAY, SPOFFORD & THORNDIKE, LLC

EXISTING DETAIL	ARM	DATE	11/10
PROPOSED DESIGN	DEM	DATE	4/13
SHEET CHECKED	TAT	DATE	4/13
AS BUILT DETAILS		DATE	

NOTEBOOKS	BOOK	PAGE
	BOOK	PAGE
	BOOK	PAGE

REVISIONS AFTER PROPOSAL	NUMBER	DATE	STATION	DESCRIPTION

GENERAL NOTES:

- THIS PLAN IS INTENDED AS A GENERAL OVERVIEW OF TEMPORARY EROSION CONTROL METHODS. PER SECTION 108.03 OF THE NHDOT STANDARD SPECIFICATIONS, THE CONTRACTOR IS REQUIRED TO PREPARE AND SUBMIT A DETAILED STORMWATER POLLUTION PREVENTION PLAN (SWPPP), WHICH REFLECTS THE CONTRACTOR'S PROPOSED SCHEDULE OF OPERATIONS.
- EROSION CONTROLS ARE TO BE CONSTRUCTED IN ACCORDANCE WITH THE DETAILS SHOWN ON THE TEMPORARY EROSION CONTROL DETAILS SHEETS AND THE NEW HAMPSHIRE STORMWATER MANUAL VOLUME 3, EROSION AND SEDIMENT CONTROLS DURING CONSTRUCTION, DECEMBER 2008.
- THE PROJECT SHALL BE MANAGED TO MEET THE REQUIREMENTS AND INTENT OF RSA 430:53 AND AGR 3800 RELATIVE TO INVASIVE SPECIES.

CONSTRUCTION SEQUENCE:

- INSTALL PROJECT-WIDE EROSION CONTROLS, INCLUDING SILT FENCES, SILT SCREENS, COMPOST SOCKS, AND CATCH BASIN AND CULVERT PROTECTION AS SHOWN ON THE PLANS PRIOR TO ANY EARTH MOVING OPERATIONS THAT WILL GENERATE STORMWATER RUNOFF.
- ALL EROSION CONTROLS SHALL BE INSPECTED WEEKLY AND AFTER EVERY 1/2" OF RAINFALL DURING THE LIFE OF THE PROJECT. ALL DAMAGED EROSION CONTROLS SHALL BE REPAIRED AT NO CHARGE TO THE OWNER. SEDIMENT DEPOSITS SHALL BE PERIODICALLY REMOVED.
- SITE PREPARATION TO INCLUDE, BUT NOT LIMITED TO PAVEMENT AND DEBRIS REMOVAL, CLEARING AND GRUBBING, TREE REMOVAL AND STRIPPING AND STOCKPILING TOPSOIL. IN GENERAL, THE CONTRACTOR SHALL LIMIT THE AREA OF DISTURBANCE COMMENSURATE WITH THE CONTRACTOR'S CAPABILITY AND PROGRESS IN KEEPING GRADING, MULCHING, SEEDING AND TEMPORARY AND PERMANENT EROSION CONTROL MEASURES CONCURRENT WITH OPERATIONS. ALL AREAS SHALL BE TEMPORARILY STABILIZED AS SOON AS PRACTICABLE, BUT WITHIN 45 DAYS OF INITIAL DISTURBANCE, AND PERMANENTLY STABILIZED AS SOON AS PRACTICABLE, BUT NO LATER THAN 3 DAYS OF FINAL GRADING. THE AREA OF UNSTABILIZED SOIL SHALL NOT EXCEED 5 ACRES AT ANY TIME. EARTH STOCKPILES ARE TO BE SEEDED AND MULCHED AND HAVE SILT FENCE INSTALLED ON THE DOWNSLOPE SIDE.

- CONSTRUCTION LAYOUT.
- CONSTRUCT TEMPORARY BRIDGE TRESTLE AND STAGING AREAS.
- REMOVE EXISTING BRIDGES AND SUBSTRUCTURES.
- EXCAVATE AND GRADE FOR BRIDGE SUBSTRUCTURES, PIERS AND RETAINING WALLS.
- CREATE TEMPORARY STOCKPILES OUTSIDE THE 50-FT WATERFRONT BUFFER SHOWN ON THE PLANS. PROPERLY REMOVE FROM SITE AND DISPOSE OF DREDGE SPOILS. STABILIZE DREDGED AREA WITH CLASS C STONE FILL TO THE LINES AND GRADES INDICATED ON THE PLANS.
- CONSTRUCT BRIDGES AND RETAINING WALLS.
- GRADE UNDERGROUND SAND FILTER AND DRAINAGE SWALES.
- INSTALL DRAINAGE SYSTEMS, PIPES, CULVERTS, SAND FILTER, DITCHES AND TEMPORARY EROSION CONTROL PROTECTIONS IN A SEQUENCE FROM OUTLET TO INLET IN ORDER TO STABILIZE OUTLET AREAS BEFORE RUNOFF IS DIRECTED TO THEM. NO STORMWATER FLOWS ARE TO BE DIRECTED TO THE UNDERGROUND SAND FILTER UNTIL CONTRIBUTING AREAS HAVE BEEN FULLY STABILIZED.
- CONSTRUCT TEMPORARY CULVERTS AND DIVERSION CHANNELS AS REQUIRED.
- ROUGH GRADE SITE TO APPROXIMATE SUBGRADES ENSURING APPROPRIATE COMPACTION WHERE REQUIRED. REMOVE UNSUITABLE SOILS AND DEWATER AS REQUIRED.
- GRADE AND GRAVEL ROADWAY AND PARKWAY AREAS. ALL ROADWAYS AND PARKING AREAS SHALL BE STABILIZED WITHIN 72 HOURS OF ACHIEVING FINISHED GRADE. THESE AREAS SHALL BE CONSIDERED STABLE WHEN BASE COURSE MATERIALS HAVE BEEN INSTALLED.
- INSTALL PERMANENT AND TEMPORARY SEEDING AND MULCHING. ALL CUT AND FILL SLOPES SHALL BE SEEDED AND MULCHED WITHIN 72 HOURS OF ACHIEVING FINISHED GRADE. THESE AREAS SHALL BE CONSIDERED STABLE WHENEVER 85% OF VEGETATIVE GROWTH IS ESTABLISHED, A MINIMUM OF 3 INCHES OF NON-EROSIVE MATERIAL HAS BEEN INSTALLED OR EROSION CONTROL BLANKETS HAVE BEEN PROPERLY INSTALLED.

- FINE GRADE AND COMPACT.
- INSTALL PAVEMENT.
- INSTALL PAVEMENT MARKINGS AND SIGNAGE.
- COMPLETE PERMANENT SEEDING AND LANDSCAPING.
- MAINTAIN AND CLEAN ALL TEMPORARY EROSION CONTROLS AND DRAINAGE FACILITIES UNTIL VEGETATED AREAS HAVE BEEN STABILIZED AND RUNOFF IS DIRECTED TOWARDS THEM.
- REMOVE ACCUMULATED SEDIMENTS FROM EROSION CONTROL DEVICES AND DISPOSE OF IN A SECURE LOCATION. REMOVE TEMPORARY EROSION CONTROLS. DISTURBED AREAS RESULTING FROM THE REMOVAL OPERATION SHALL BE PERMANENTLY SEEDED.
- WINTER NOTES:
 - ALL PROPOSED VEGETATED AREAS WHICH DO NOT EXHIBIT A MINIMUM OF 85% VEGETATIVE GROWTH BY OCTOBER 15TH, OR WHICH ARE DISTURBED AFTER OCTOBER 15TH, SHALL BE STABILIZED BY SEEDING AND INSTALLING EROSION CONTROL BLANKETS ON SLOPES GREATER THAN 3:1, AND SEEDING AND PLACING 3 TO 4 TONS OF MULCH PER ACRE, SECURED WITH ANCHORED NETTING ELSEWHERE. THE INSTALLATION OF EROSION CONTROL BLANKETS OR MULCH AND NETTING SHALL NOT OCCUR OVER ACCUMULATED SNOW OR ON FROZEN GROUND AND SHALL BE COMPLETED IN ADVANCE OF THAW OR SPRING MELT EVENTS.
 - ALL DITCHES OR SWALES WHICH DO NOT EXHIBIT A MINIMUM OF 85% VEGETATIVE GROWTH BY OCTOBER 15TH, OR WHICH ARE DISTURBED AFTER OCTOBER 15TH, SHALL BE STABILIZED TEMPORARILY WITH STONE OR EROSION CONTROL BLANKETS APPROPRIATE FOR THE DESIGN FLOW CONDITIONS.
 - AFTER NOVEMBER 15TH, INCOMPLETE ROAD OR PARKING SURFACES WHERE WORK HAS STOPPED FOR THE WINTER SEASON SHALL BE PROTECTED WITH A MINIMUM OF 3 INCHES OF CRUSHED GRAVEL PER NHDOT ITEM 304.3.
 - THE SITE SHALL BE STABILIZED IN ACCORDANCE WITH ENV-WQ 1505.05 FOR CONSTRUCTION TAKING PLACE DURING THE PERIOD OF NOVEMBER 30TH THROUGH MAY 1ST.

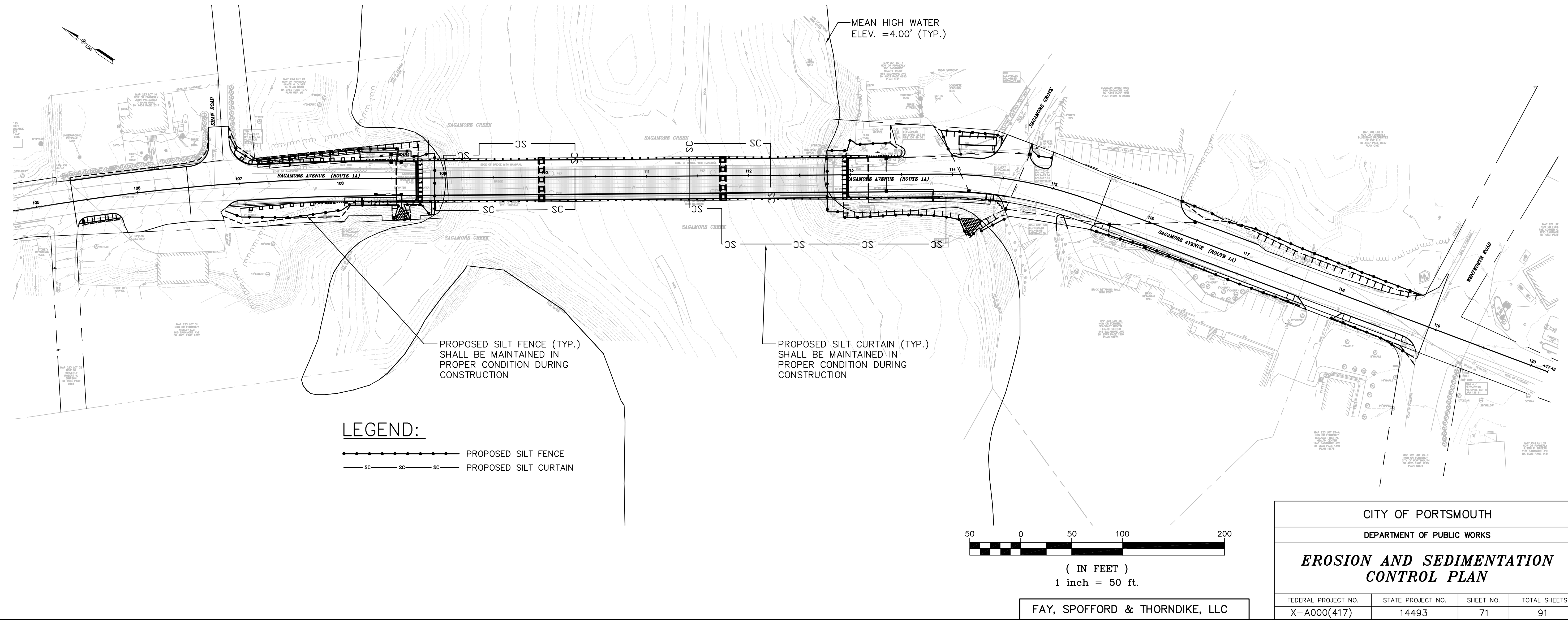

CITY OF PORTSMOUTH			
DEPARTMENT OF PUBLIC WORKS			
EROSION AND SEDIMENTATION CONTROL PLAN			
FEDERAL PROJECT NO.	STATE PROJECT NO.	SHEET NO.	TOTAL SHEETS
X-A000(417)	14493	71	91

FAY, SPOFFORD & THORNDIKE, LLC

EXISTING DETAIL	ARM	DATE	11/10
PROPOSED DESIGN	DEM	DATE	4/13
SHEET CHECKED	TAT	DATE	4/13
AS BUILT DETAILS		DATE	

NUMBER	DATE	STATION	STATION	DESCRIPTION

NOTEBOOKS	PAGE
BOOK	PAGE
BOOK	PAGE
BOOK	PAGE

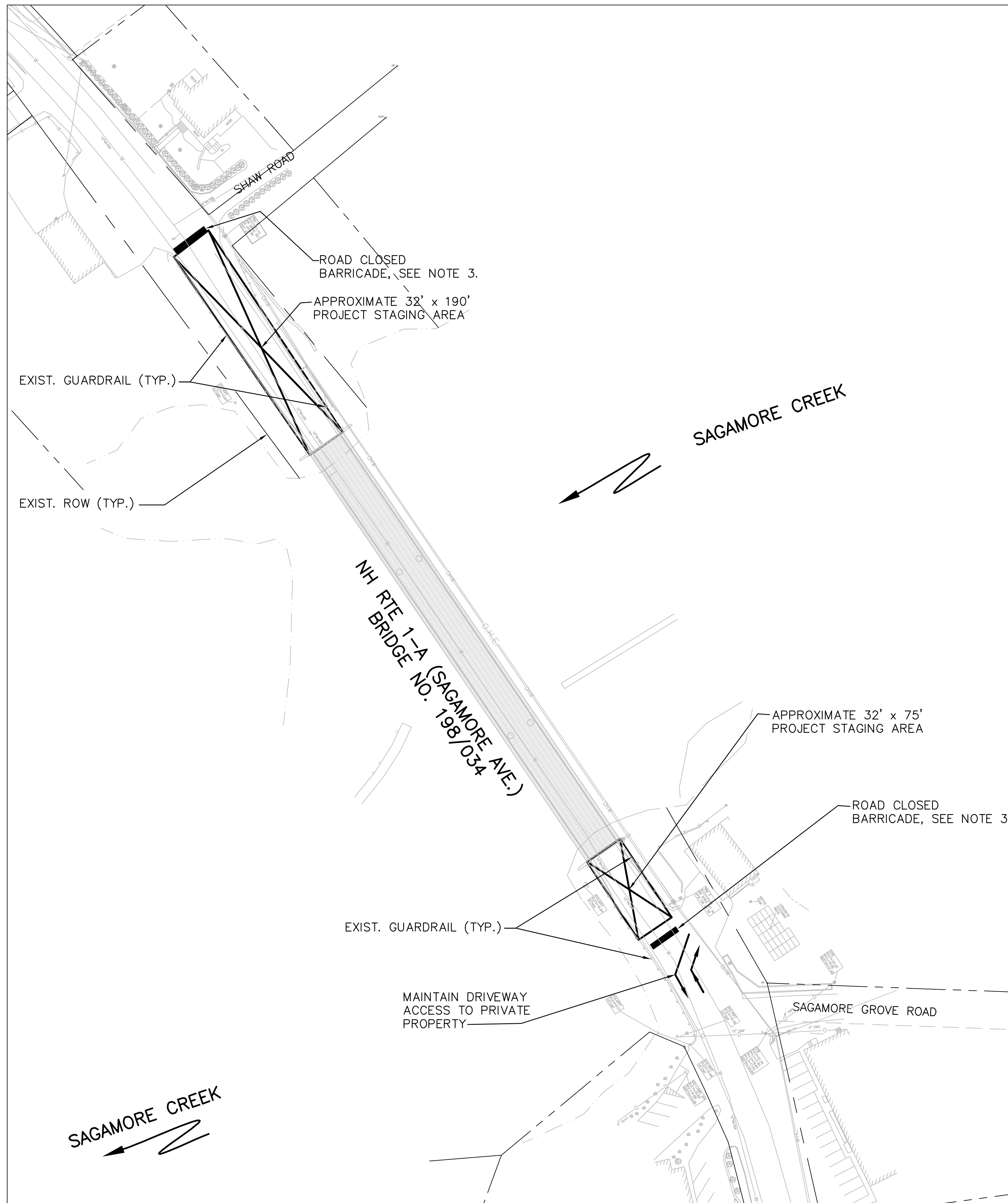

SITE / STAGING PLAN

APPROX. SCALE : 1" = 50'

DETOUR & TRAFFIC CONTROL NOTES:

1. THE EXISTING TRUCK DETOUR CURRENTLY IN PLACE WILL SERVE AS THE "ALL-TRAFFIC" DETOUR DURING THE CLOSURE FOR BRIDGE REPLACEMENT WORK.
2. THE CONTRACTOR WILL FURNISH, INSTALL, AND MAINTAIN DETOUR SIGNAGE THROUGHOUT THE PROJECT DURATION.
3. THE CONTRACTOR SHALL FURNISH, INSTALL AND MAINTAIN ROAD CLOSED BARRICADES AT THE PROJECT STAGING AREAS ON EACH END OF THE BRIDGE AS REQUIRED TO PROVIDE WORK ZONE ISOLATION, SAFETY, AND WORK ACCESS. EACH ROAD CLOSED BARRICADE, AT A MINIMUM, SHALL CONSIST OF WEIGHTED ORANGE TRAFFIC BARRELS AT 4' O/C, BARRICADE WARNING BOARD, ROAD CLOSED SIGN, AND FLASHING YELLOW BARREL-MOUNTED WARNING LIGHTS. ROAD CLOSED BARRICADES AND ALL INCIDENTAL WORK SHALL BE SUBSIDIARY TO ITEM 692 - MOBILIZATION.
4. CRASHWORTHY BARRICADE TO BE INSTALLED TO PROTECT PROJECT AREA DURING DEMOLITION AND CONSTRUCTION.

SITE / STAGING PLAN NOTES:

1. PROJECT STAGING AREAS SHOWN ARE APPROXIMATE. ALL CONSTRUCTION OPERATIONS TO BE MAINTAINED WITHIN THE EXISTING RIGHT-OF-WAY UNLESS SPECIFIC EASEMENTS AND RIGHT-OF-ENTRY IS OBTAINED BY THE CONTRACTOR FOR THE PROPOSED WORK PLAN.
2. ALL PROJECT STAGING AREAS AND WORK SHALL BE ABOVE TOP OF BANK ELEVATION OF SAGAMORE CREEK.

CITY OF PORTSMOUTH			
DEPARTMENT OF PUBLIC WORKS			
SITE STAGING PLAN			
FEDERAL PROJECT NO.	STATE PROJECT NO.	SHEET NO.	TOTAL SHEETS
X-A000(417)	14493	72	91

FAY, SPOFFORD & THORNDIKE, LLC

EXISTING DETAIL	ARM	DATE	11/10
PROPOSED DESIGN	DEM	DATE	4/13
SHEET CHECKED	TAT	DATE	4/13
AS BUILT DETAILS		DATE	

REVISIONS AFTER PROPOSAL	STATION	DESCRIPTION

NOTEBOOKS	PAGE	PAGE	PAGE
BOOK			
BOOK			
BOOK			

NUMBER	DATE	STATION	DESCRIPTION

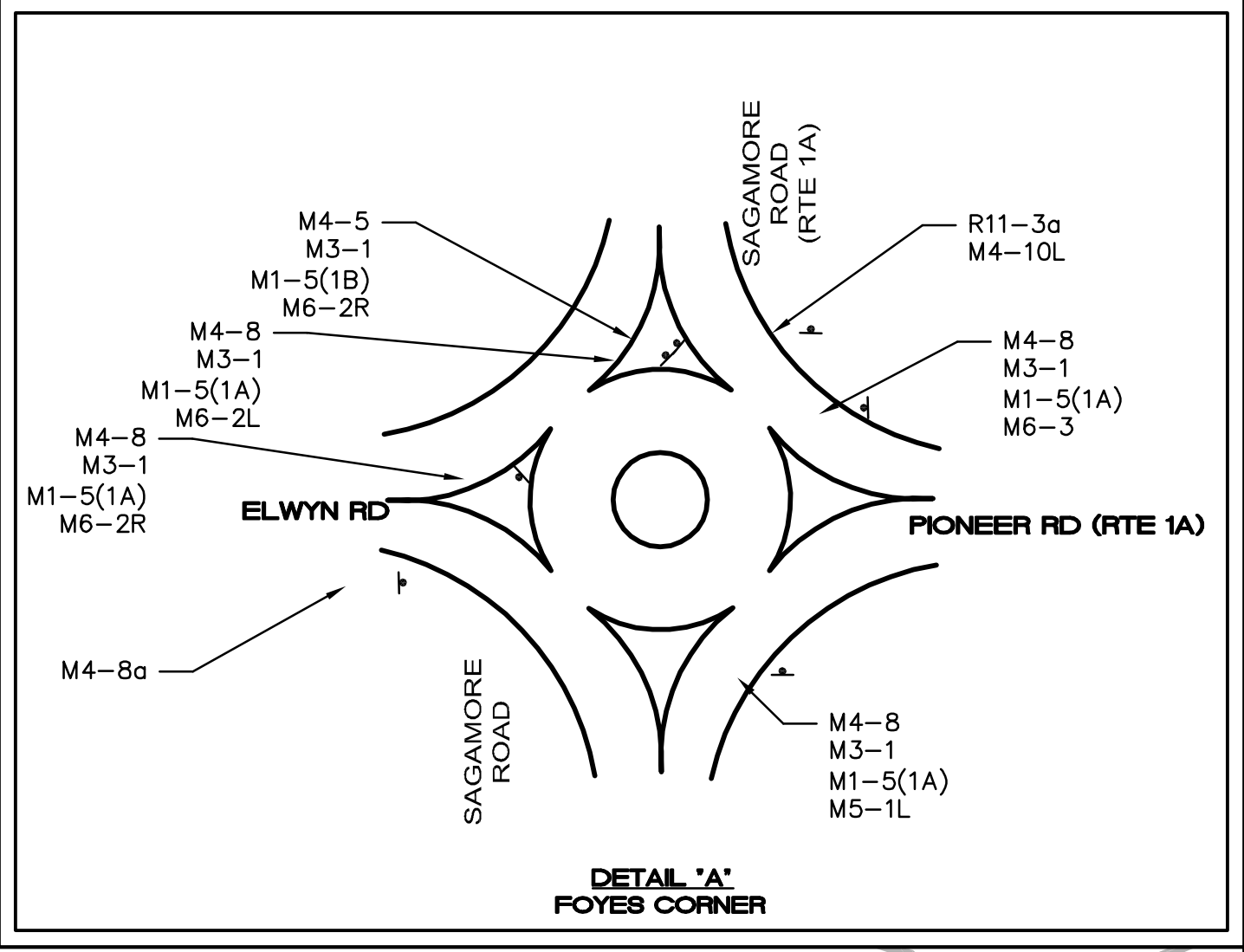
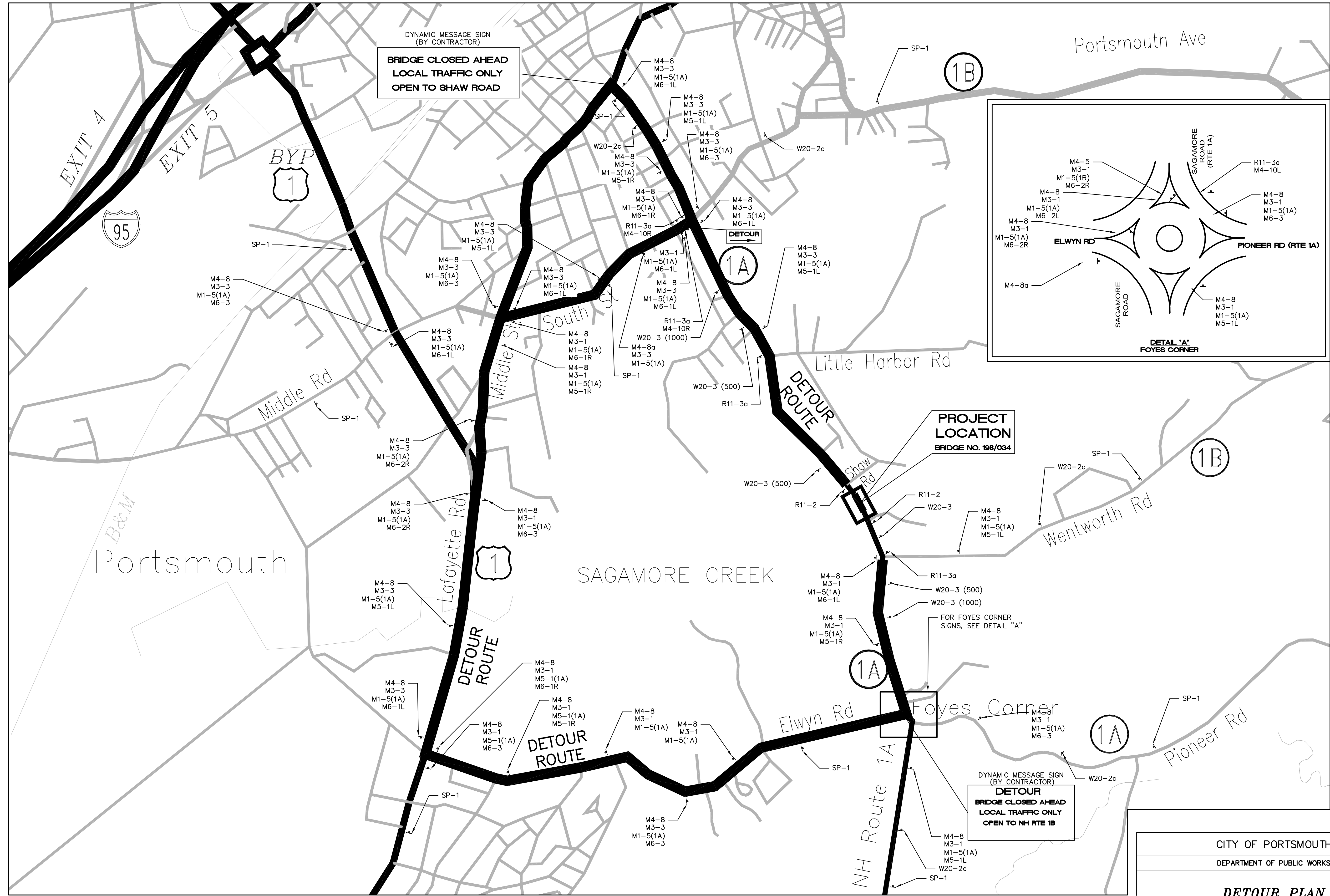

DETOUR PLAN

SCALE : 1" = 1/2 MILE

FAY, SPOFFORD & THORNDIKE, LLC

CITY OF PORTSMOUTH			
DEPARTMENT OF PUBLIC WORKS			
DETOUR PLAN			
FEDERAL PROJECT NO.	STATE PROJECT NO.	SHEET NO.	TOTAL SHEETS
X-A000(417)	14493	73	91

EXISTING DETAIL		ARM	DATE	11/10
PROPOSED DESIGN		DEM	DATE	4/13
SHEET CHECKED		TAT	DATE	4/13
AS BUILT DETAILS			DATE	
REVISIONS AFTER PROPOSAL				
NUMBER	DATE	STATION	STATION	DESCRIPTION
NOTEBOOKS		BOOK	PAGE	
		BOOK	PAGE	
		BOOK	PAGE	

ITEM #	IDENT #	SIGN SIZE		TEXT	TEXT DIMENSIONS			SHIELD SIZE (inch)	ARROW (inch)	NUMERAL (inch)	# SIGNS REQ'D	SIGN AREA (SQ. FT.)		POSTS PER SIGN					REMARKS	
		WIDTH (inch)	HEIGHT (inch)		LETTER HEIGHT (inch)							NOM AREA	TOTAL AREA	BREAKAWAY	STEEL I-BEAM	CONCRETE BASE	4" ALUMINUM	U-CHANNEL-GALV.		
					UC	LC	CAPS													
619.1	R11-2	48	30	ROAD CLOSED			8D				2	10.0	20.0							BLACK/WHITE
619.1	R11-3a	60	30	ROAD CLOSED AT SAGAMORE CREEK LOCAL TRAFFIC ONLY			6C				5	12.5	62.5						2	BLACK/WHITE
619.1	W20-2c	36	36	DETOUR AHEAD			6D				5	9.0	45.0						1	BLACK/ORANGE
619.1	W20-3	36	36	ROAD CLOSED AHEAD			5D				1	9.0	9.0						1	BLACK/ORANGE
619.1	W20-3 (XX)	36	36	ROAD CLOSED XX FT			5D				5	9.0	45.0						1	BLACK/ORANGE
619.1	M1-5 (1A)	24	24	1A			12D				37	4.0	148.0						1	BLACK/ORANGE
619.1	M1-5 (1B)	24	24	1B			12D				1	4.0	4.0						1	BLACK/ORANGE
619.1	M3-1	24	12	NORTH			6C				19	2.0	38.0							BLACK/ORANGE
619.1	M3-3	24	12	SOUTH			6C				19	2.0	38.0							BLACK/ORANGE
619.1	M4-5	24	12	TO			6E				1	2.0	2.0							BLACK/ORANGE
619.1	M4-8	24	12	DETOUR			6B				35	2.0	70.0							BLACK/ORANGE
619.1	M4-8a	24	18	END DETOUR			4D				2	3.0	6.0						1	BLACK/ORANGE
619.1	M4-10L	48	18	← DETOUR			6D				1	6.0	6.0							BLACK/ORANGE
619.1	M4-10R	48	18	DETOUR →			6D				2	6.0	12.0							BLACK/ORANGE
619.1	M5-1L	15	21	↙							7	2.1875	15.3125							BLACK/ORANGE
619.1	M5-1R	15	21	↘							4	2.1875	8.75							BLACK/ORANGE
619.1	M6-1R	15	21	→							3	2.1875	6.5625							BLACK/ORANGE
619.1	M6-1L	15	21	←							8	2.1875	17.5							BLACK/ORANGE
619.1	M6-2R	15	21	↗							4	2.1875	8.75							BLACK/ORANGE
619.1	M6-2L	15	21	↖							1	2.1875	2.1875							BLACK/ORANGE
619.1	M6-3	15	21	↑							8	2.1875	17.5							BLACK/ORANGE
619.1	SP-1	60	30	ROUTE 1A SAGAMORE CREEK BRIDGE CLOSED			6C				10	12.5	125.0						2	BLACK/WHITE
619.1	SP-2	60	30	SHAW ROAD LOCAL TRAFFIC ONLY			6C				1	12.5	12.5							BLACK/WHITE

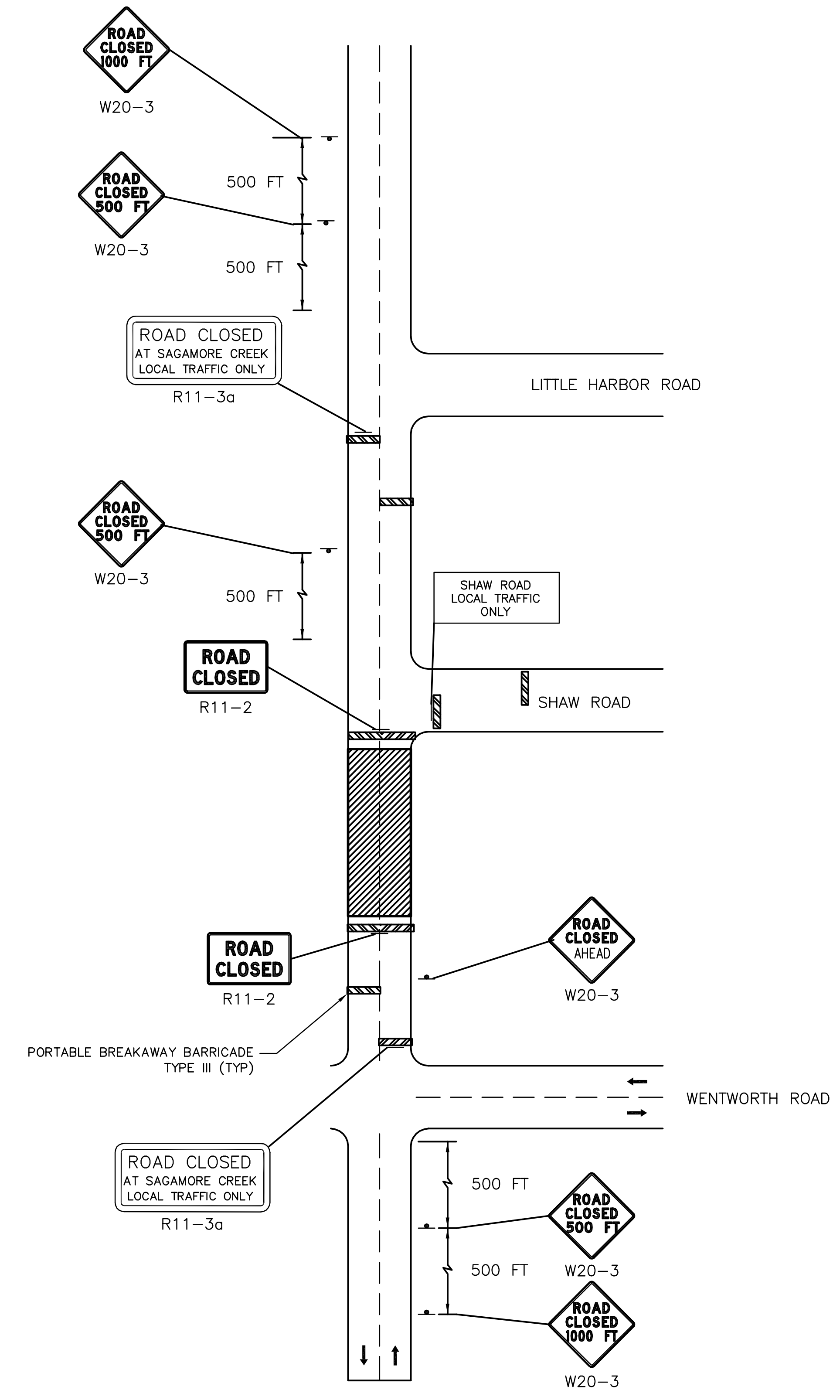

WORK AREA SIGNS
NOT TO SCALE

CITY OF PORTSMOUTH			
DEPARTMENT OF PUBLIC WORKS			
DETOUR SIGN SUMMARY			
FEDERAL PROJECT NO.	STATE PROJECT NO.	SHEET NO.	TOTAL SHEETS
X-A000(417)	14493	74	91