

**CONTRACT DOCUMENTS AND SPECIFICATIONS**

for

**Prescott Park Pavilion Building 2013  
Bid Proposal #18-14**

## Prescott Park Pavilion Building 2013

### INVITATION TO BID

**Sealed** bid proposals, **plainly marked, Prescott Park Pavilion 2013, Bid Proposal #18-14 on the outside of the mailing envelope as well as the sealed bid envelope,** addressed to the Finance/Purchasing Department, City Hall, 1 Junkins Avenue, Portsmouth, New Hampshire, 03801, will be accepted until October 16, 2013 at 2:00 p.m. at which time all bids will be publicly opened and read aloud. A mandatory pre-bid meeting will be held September 30, 2013 at 10:00 a.m. at the Prescott Park Pavilion, on Marcy Street, Portsmouth, N.H.

The work shall consist of the removal of the existing concession and the installation of a new pavilion building including kitchen space and new bathrooms and associated site work.

**Completion date will be June 1, 2014.**

**Contractors must have at least five (5) years of demonstrated experience in the building field.** Bidders must determine the quantities of work required and the conditions under which the work will be performed.

Specifications, drawings, and bid proposal forms may be obtained from the City website at <http://www.cityofportsmouth.com/finance/purchasing.htm>. Questions may be directed to Tom Richter, Project Manager at (603) 766-1412. Addenda to this bid document, if any, including written answers to questions, will be posted on the City of Portsmouth website at <http://www.cityofportsmouth.com/finance/purchasing.htm> under the project heading. Addenda and updates will NOT be sent directly to vendors.

The City of Portsmouth reserves the right to reject any or all bids, to waive technical or legal deficiencies, to re-bid, and to accept any bid that it may deem to be in the best interest of the City.

Each Bidder shall furnish a bid security in the amount of ten percent (10%) of the bid. The Bid Security may be in the form of a certified check or a bid bond executed by a surety company authorized to do business in the State of New Hampshire, made payable to the City of Portsmouth, N.H.

## INSTRUCTIONS TO BIDDERS

### **BIDDING REQUIREMENTS AND CONDITIONS**

#### 1. Special Notice to Bidders

Appended to these instructions is a complete set of bidding and general contract forms. These forms may be detached and executed for the submittal of bids. The plans, specifications, and other documents designated in the proposal form will be considered as part of the proposal, whether attached or not.

The bidders must submit a statement of bidder's qualifications, if requested, subsequent to bid opening but prior to award.

Addenda to this proposal, if any, including written answers to questions, will be posted on the City of Portsmouth website at <http://www.cityofportsmouth.com/finance/purchasing.htm> under the project heading. Addenda and updates will **NOT** be sent directly to firms. Contractors submitting a bid should check the web site daily for addenda and updates after the release date. Firms should print out, sign and return addenda with the proposal. Failure to do so may result in disqualification.

#### 2. Interpretation of Quantities in Bid Schedules

The quantities appearing in the bid schedule are approximate only and are prepared for the comparison of bids. Payment to the contractor will be made only for actual work performed and accepted in accordance with the contract. Any scheduled item of work to be done and materials to be furnished may be increased, decreased or omitted as hereinafter provided, and no claim for loss, anticipated profits or costs incurred in anticipation of work not ultimately performed will be allowed due to such increase or decrease.

#### 3. Examination of Plans, Specifications and Site Work

The bidder is expected to examine carefully the site of the proposed work, the plans, standard specifications, supplemental specifications, special provisions and contract forms before submitting a proposal. The submission of a bid shall be considered conclusive evidence that the bidder has made such examination and is satisfied as to the conditions to be encountered in performing the work and as to the requirements of the contract. It will be conclusive evidence that the bidder has also investigated and is satisfied with the sources of supply for all materials.

Plans, surveys, measurements, dimensions, calculations, estimates and statements as to the condition under which the work is to be performed are believed to be correct, but the contractors must examine for themselves, as no allowance will be made for any errors or inaccuracies that maybe found therein.

#### 4. Familiarity with Laws

The bidder is assumed to have made himself or herself familiar with all federal and state laws and all local by-laws, ordinances and regulations which in any manner affect those engaged or employed on the work or affect the materials or equipment used in the work or affect the conduct of the work, and the bidder, if awarded the contract, shall be obligated to perform the work in conformity with said laws, by-laws, ordinances and regulations notwithstanding its ignorance thereof. If the bidder shall discover any provision in the plans or specifications which is in conflict with any such law, by-law, ordinance or regulation the bidder shall forthwith report it to the engineer in writing.

## 5. Preparation of Proposal

a) The bidder shall submit its proposal upon the forms furnished by the Owner. The bidder shall specify a lump sum price in figures, for each pay item for which a quantity is given and shall also show the products of the respective prices and quantities written in figures in the column provided for that purpose and the total amount of the proposal obtained by adding the amount of the several items. All words and figures shall be in ink or typed. If a unit price or a lump sum bid already entered by the bidder on the proposal form is to be altered it should be crossed out with ink, the new unit price or lump sum bid entered above or below it and initialed by the bidder, also with ink.

b) The bidder's proposal must be signed with ink by the individual, by one or more general partners of a partnership, by one or more members or officers of each firm representing a joint venture; by one or more officers of a corporation, by one or more members (if member-managed) or managers (if manager-managed) of a limited liability company, or by an agent of the contractor legally qualified and acceptable to the owner. If the proposal is made by an individual, his or her name and post office address must be shown, by a partnership the name and post office address of each general and limited partner must be shown; as a joint venture, the name and post office address of each venturer must be shown; by a corporation, the name of the corporation and its business address must be shown, together with the name of the state in which it is incorporated, and the names, titles and business addresses of the president, secretary and treasurer.

## 6. Nonconforming Proposals

Proposals will be considered nonconforming and may be rejected in the Owner's sole discretion for any of the following reasons:

- If the proposal is on a form other than that furnished by the Owner, or if the form is altered or any portion thereof is detached;
- If there are unauthorized additions, conditional or altered bids, or irregularities of any kind which may tend to make the proposal or any portion thereof incomplete, indefinite or ambiguous as to its meaning;
- If the bidder adds any provisions reserving the right to accept or reject an award, or to enter into a contract pursuant to an award; or
- If the proposal does not contain a unit price for each pay item listed except in the case of authorized alter pay items.

## 7. Proposal Guaranty

No proposal will be considered unless accompanied by a bid bond, surety, or similar guaranty of the types and in an amount not less than the amount indicated in the Invitation to Bid. All sureties shall be made payable to the "City of Portsmouth". If a bid bond is used by the bidder it shall be:

- In a form satisfactory to the Owner;
- With a surety company licensed, authorized to do business in, and subject to the jurisdiction of the courts of the State of New Hampshire; and
- Conditioned upon the faithful performance by the principal of the agreements contained in the sub-bid or the general bid.

In the event any irregularities are contained in the proposal guaranty, the bidder will have four business days (not counting the day of opening) to correct any irregularities. The corrected guaranty must be received by 4:00 p.m. If irregularities are not corrected to the satisfaction of the Owner, the Owner, in its sole discretion, may reject the bid.

#### 8. Delivery of Proposals

When sent by mail, the sealed proposal shall be addressed to the Owner at the address and in the care of the official in whose office the bids are to be received. All proposals shall be filed prior to the time and at the place specified in the invitation for bids. Proposals received after the time for opening of the bids will be returned to the bidder, unopened.

#### 9. Withdrawal of Proposals

A bidder will be permitted to withdraw his or her proposal unopened after it has been submitted if the Owner receives a request for withdrawal in writing prior to the time specified for opening the proposals.

#### 10. Public Opening of Proposals

Proposals will be opened and read publicly at the time and place indicated in the invitation for bids. Bidders, their authorized agents, and other interested parties are invited to be present.

#### 11. Disqualification of Bidders

Any or all of the following reasons may be deemed by Owner in its sole discretion as being sufficient for the disqualification of a bidder and the rejection of his proposal:

- More than one proposal for the same work from an individual, firm, or corporation under the same or different name;
- Evidence of collusion among bidders;
- Failure to submit all required information requested in the bid specifications;
- **Contractor lacks sufficient experience in the building trade (5 years);**
- Lack of competency or of adequate machinery, plant or other equipment, as revealed by the statement of bidders qualification or otherwise;
- Uncompleted work which, in the judgment of the owner, might hinder or prevent the prompt completion of additional work if awarded;
- Failure to pay, or satisfactorily settle, all bills due for labor and materials on former contracts;
- Default or unsatisfactory performance on previous contracts; or
- Such disqualification would be in the best interests of the Owner.

#### 12. Material Guaranty and Samples

Before any contract is awarded, the bidder may be required to furnish a complete statement of the origin, composition and manufacture of any or all materials to be used in the construction of the work, and the Owner may, in its sole discretion, reject the bid based on the contents of the statement or as a result of the failure of the bidder to submit the statement.

## AWARD AND EXECUTION OF CONTRACT

### 1. Consideration of Proposals

a) After the proposals are opened and read, they will be compared on the basis of the total price for all sections of work to be charged to perform the work and any such additional considerations as may be identified in the bid documents. The results of such comparisons will be immediately available to the public. In case of a discrepancy between the prices written in words and those written figures, the prices written in words shall govern. In case of a discrepancy between the total shown in the proposal and that obtained by adding the products of the quantities of items and unit bid prices, the latter shall govern.

### 2. Award of Contract

Within 30 calendar days after the opening of proposals, if a contract is to be awarded, the award will be made to the lowest responsible and qualified bidder whose proposal complies with all the requirements prescribed. The successful bidder will be notified, in writing, mailed to the address on his or her proposal, that his or her bid has been accepted and that the bidder has been awarded the contract.

The award shall not be considered official until such time that a Purchase Order, fully executed contract or an award letter has been issued by the Finance Director. No presumption of award shall be made by the bidder until such documents are in hand. Verbal notification of award is not considered official. Any action by the bidder to assume otherwise is done so at his/her own risk and the City will not be held liable for any expense incurred by a bidder that has not received an official award.

**Basis of award will be based on the Base Bid.**

**Contract award is dependent upon available funds.**

**Contractors may be requested to break down contract pricing for comparative purposes.**

### 3. Reservation of Rights

The Owner reserves the right to reject any or all proposals, to waive technicalities or to advertise for new proposals, if, in the sole discretion of the Owner, the best interest of the City of Portsmouth will be promoted thereby.

The City reserves the right to make inquiries regarding the qualifications and reputation of the bidder. By submitting a bid proposal, bidder agrees to hold harmless the Owner and its employees and agents from any and all claims, actions, and damages arising from such investigation. Bidder may be requested to execute releases.

The Owner reserves the right to cancel the award of any contract at any time before the execution of such contract by all parties without any liability of the Owner.

### 4. Return of Proposal Guaranty

All proposal guaranties, except those of the three lowest bidders, will be returned upon request following the opening and checking of the proposals. The proposal guaranties of the three lowest bidders will be returned within ten days following the award of the contract if requested.

5. Contract Bonds

At the time of the execution of the contract, the successful bidder shall furnish:

- A performance bond in the amount of 100 percent of the contract amount.
- Labor and materials payment bond in the sum equal to 100 percent of the contract amount.

At the time of project completion, the Owner may, in its sole discretion, permit the Contractor to substitute a maintenance bond in lieu of holding retainage for the entire guaranty period. If a bond is furnished it shall meet the following criteria:

- The bond shall be in an amount equal to 20 percent of the contract amount. Such bond shall guarantee the repair of all damage due to faulty materials or workmanship provided or done by the contractor. The guarantee shall remain in effect for a period of one year after the date of final acceptance of the job by the Owner.

Each bond shall be: (1) in a form satisfactory to the Owner; (2) with a surety company licensed and authorized to do business and with a resident agent designated for services of process in the State of New Hampshire; and (3) conditioned upon the faithful performance by the principal of the agreements contained in the original bid. All premiums for the contract bonds are to be paid by the contractor.

6. Execution and Approval of Contract

The successful bidder is required to present all contract bonds, to provide proof of insurance, and to execute the contract within 10 days following receipt of the City's notification of acceptance of the bid. No contract shall be considered as in effect until it has been fully executed by all parties.

7. Failure to Execute Contract

Failure to execute the contract and file acceptable bonds within 10 days after notification of acceptance of bid shall be just cause for the cancellation of the award and the forfeiture of the proposal guarantee which shall become the property of the Owner, not as a penalty, but in liquidation of damages sustained. Award may then be made to the next lowest responsible bidder, or the City may exercise its reserved rights including the rejection of all bids or re-advertisement.

## PROPOSAL FORM

### **Prescott Park Pavilion Building 2013**

CITY OF PORTSMOUTH, N.H.

To the City of Portsmouth, New Hampshire, herein called the Owner.

The undersigned, as Bidder, herein referred to as singular and masculine declares as follows:

1. All interested in the Bid as Principals are named herein.
2. This bid is not made jointly, or in conjunction, cooperation or collusion with any other person, firm, corporation, or other legal entity;
3. No officer, agent or employee of the Owner is directly or indirectly interested in this Bid.
4. The bidder has carefully examined the sites of the proposed work and fully informed and satisfied himself as to the conditions there existing, the character and requirements of the proposed work, the difficulties attendant upon its execution and the accuracy of all estimated quantities stated in this Bid, and the bidder has carefully read and examined the Drawings ("Prescott Park: Pavilion Building" by McHenry Architecture PLLC), Agreement, Specifications and other Contract Documents therein referred to and knows and understands the terms and provisions thereof;
5. There will be a mandatory pre-bid meeting held approximately one week prior to receipt of bids, to review Bidding documents with bidders. **Meeting will be 10:00 a.m., September 30, 2013 at Prescott Park, Marcy Street, Portsmouth, NH.**
6. The bidder understands that the quantities of work calculated in the Bid or indicated on the Drawings or in the Specifications or other Contract Documents are approximate and are subject to increase or decrease or deletion as deemed necessary by the Portsmouth City Engineer. Any such changes will not result in or be justification for any penalty or increase in contract prices; and agrees that, if the Bid is accepted the bidder will contract with the Owner, as provided in the Contract Documents, this Bid Form being part of said Contract Documents, and that the bidder will supply or perform all labor, services, plant, machinery, apparatus, appliances, tools, supplies and all other activities required by the Contract Documents in the manner and within the time therein set forth, and that the bidder will take in full payment therefor the following item prices;
7. The bidder shall provide (3) references of completed projects of similar scope and size;
8. It is the intention of this contract that the items listed above describe completely and thoroughly the entirety of the work as shown on the plans and as described in the specifications. All other items required to accomplish the above items are considered to be subsidiary work, unless shown as a pay item, to wit:

**THIS PROJECT SHALL BE BID BY LUMP SUM WITH ALTERNATES:**

Alternate #1: Interior/Exterior Trim

Base Bid: Azek Traditional Trim

Alternate Product: Premium Grade, Western Red Cedar Wood Trim, Painted

Alternate #2: Women's Room #104/Men's Room #106 Wall Finish Material

Base Bid: Crossville Color Blox 6x12 Ceramic Tile, Running Bond



Alternate Product: Marlite Wall Panel System, Standard, Pebble Finish, White

Alternate #3: Existing Building Demolition

Base Bid: Partial demolition as outlined on Sheet A1 of the drawing set

Alternate: Complete demolition of the existing building. (Any remainder of the building that is not already called out for removal or demolition on Sheet A1 of the drawing set)

Total Amount of Base Bid compiled by the Bidder.

In Figures \$ \_\_\_\_\_

In Words \_\_\_\_\_ Dollars

For accounting purposes only, Bidder shall provide the following additional bid breakdown.

Plumbing Subcontract \$ \_\_\_\_\_

Mechanical Subcontract \$ \_\_\_\_\_

Electrical Subcontract \$ \_\_\_\_\_

Civil Subcontract \$ \_\_\_\_\_

General Conditions \$ \_\_\_\_\_

Cost of Alternate #1 compiled by the Bidder.

In Figures \$ \_\_\_\_\_

In Words \_\_\_\_\_ Dollars

Cost of Alternate #2 compiled by the Bidder.

In Figures \$ \_\_\_\_\_

In Words \_\_\_\_\_ Dollars

Cost of Alternate #3 compiled by the Bidder.

In Figures \$ \_\_\_\_\_

In Words \_\_\_\_\_ Dollars

**Basis of award will be based on the Base Bid**

**Contract award is contingent upon available funding.**

**Contractors may be requested to break down contract pricing for comparative purposes.**

PART 1 - To Bidder: It is the intention of this contract that the items listed above describe completely and thoroughly the entirety of the work as shown on the plans and as described in the specifications. All other

items required to accomplish the above items are considered to be subsidiary work, unless shown as a pay item.

The undersigned agrees that for extra work, if any, performed in accordance with the terms and provisions of the Contract Documents, the bidder will accept compensation as stipulated therein.

---

DATE COMPANY

BY: \_\_\_\_\_

---

SIGNATURE TITLE

---

STREET ADDRESS, CITY, STATE, ZIPCODE, TELEPHONE NUMBER

The Bidder has received and acknowledged Addenda No. \_\_\_\_\_ through \_\_\_\_\_.

All Bids are to be submitted on this form and in a sealed envelope, plainly marked on the outside with the Bidder's name and address and the Project name as it appears at the top of the Proposal Form.

**BID SECURITY BOND**

(This format provided for convenience, actual Bid Bond is acceptable in lieu of, if compatible.)

KNOW ALL MEN BY THESE PRESENTS, that we the undersigned

\_\_\_\_\_, as Principal, and

\_\_\_\_\_, as Surety, are hereby

held and firmly bound unto \_\_\_\_\_

IN THE SUM OF \_\_\_\_\_

as liquidated damages for payment of which, well and truly to be made we hereby jointly and severally bind ourselves, our heirs, executors, administrators, successors and assigns.

The condition of this obligation is such that whereas the Principal has submitted to the

\_\_\_\_\_ A CERTAIN Bid attached hereto and hereby made a part hereof to enter into a contract in writing, hereinafter referred to as the "AGREEMENT" and or "CONTRACT", for

\_\_\_\_\_  
\_\_\_\_\_  
\_\_\_\_\_

NOW THEREFORE,

- (a) If said Bid shall be rejected or withdrawn as provided in the INFORMATION FOR BIDDERS attached hereto or, in the alternative,
- (b) If said Bid shall be accepted and the Principal shall duly execute and deliver the form of AGREEMENT attached hereto and shall furnish the specified bonds for the faithful performance of the AGREEMENT and/or CONTRACT and for the payment for labor and materials furnished for the performance of the AGREEMENT and or CONTRACT,

then this obligation shall be void , otherwise it shall remain in full force and effect; it being expressly understood and agreed that the liability of the Surety for any and all claims hereunder in no event shall exceed the amount of this obligation.

**BID SECURITY BOND** (continued)

The Surety, for value received, hereby agrees that the obligation of said surety and its bond shall be in no way impaired or affected by any extensions of the time within such BID may be accepted, and said Surety does hereby waive notice of any such extension.

IN WITNESS WHEREOF, the parties hereto have duly executed

this bond on the \_\_\_\_\_ day of \_\_\_\_\_, 20\_\_.

\_\_\_\_\_ L.S.  
(Name of Principal)

(SEAL)

BY \_\_\_\_\_

\_\_\_\_\_  
(Name of Surety)

BY \_\_\_\_\_

**STATEMENT OF BIDDER'S QUALIFICATIONS**

Supply with Bid

**All questions must be answered and the data given must be clear and comprehensive. Add separate sheets if necessary**

1. Name of Bidder
2. Permanent Main Office Address
3. Form of Entity
4. When Organized
5. Where Organized
6. How many years have you been engaged in the contracting business under your present name; also state names and dates of previous firm names, if any.
7. Contracts on hand; (schedule these, showing gross amount of each contract and the approximate anticipated dates of completion).
8. General character of work performed by your company.
9. Have you failed within the last seven years to complete any work awarded to you?  
\_\_\_\_(no)\_\_\_\_(yes). If so, where and why?
10. Have you defaulted on a contract within the last seven years?  
\_\_\_\_(no)\_\_\_\_(yes). If so, where and why?
11. Have you ever failed to complete a project in the time allotment according to the Contract Documents?  
\_\_\_\_\_(no)\_\_\_\_\_(yes). If so, where and why?
12. List the most important contracts recently executed by your company, stating approximate cost for each, and the month and year completed.
13. List your major equipment available for this contract.
14. List your key personnel such as project superintendent and foremen available for this contract.
15. List any subcontractors whom you would expect to use for the following (unless this work is to be done by your own organization).
  - a. Mechanical & Plumbing Work\_\_\_\_\_
  - b. Framing Work\_\_\_\_\_
  - c. Electrical Work \_\_\_\_\_
  - d. Flooring Work\_\_\_\_\_

(The City reserves the right to approve or disapprove subcontractors for this project)

**STATEMENT OF BIDDERS QUALIFICATIONS** (continued)

16. Contractor must have at least five years prior experience in commercial/municipal construction projects. Describe that prior experience, identifying projects/contracts that have been successfully completed within the last five years.

---

---

---

---

Latest Financial Statements: The City reserves the right to request Bidders' latest Financial Statements. Certified audited statements if available, prepared by an independent certified public accountant, may be requested by Owner. If requested, such statements must be provided within five (5) business days or the bid proposal will be rejected. Certified Audited Statement are preferred. Internal statements may be used only if independent statements were not prepared.

Dated at \_\_\_\_\_ this \_\_\_\_\_ day of \_\_\_\_\_, 20\_\_.

\_\_\_\_\_  
Name of Bidder

BY \_\_\_\_\_

TITLE \_\_\_\_\_

State of \_\_\_\_\_

County of \_\_\_\_\_

\_\_\_\_\_ being duly sworn, deposes and

says that the bidder is \_\_\_\_\_ of \_\_\_\_\_  
(Name of Organization)

and answers to the foregoing questions and all statements contained therein are true and correct.

Sworn to before me this \_\_\_\_ day of \_\_\_\_\_, 20\_\_.

\_\_\_\_\_  
Notary of Public

My Commission expires \_\_\_\_\_

## CONTRACT AGREEMENT

### **Prescott Park Pavilion Building 2013**

THIS AGREEMENT made as of the \_\_\_ day of \_\_\_\_\_ in the year **2013**, by and between the City of Portsmouth, New Hampshire (hereinafter call the Owner) and \_\_\_\_\_ (hereinafter called the Contractor),

WITNESSETH; that the Owner and Contractor, in consideration of the mutual covenants hereinafter set forth, agree as follows:

**ARTICLE I - Work** - The Contractor shall perform all work as specified or indicated in the Contract Documents for the completion of the Project. The Contractor shall provide, at his expense, all labor, materials, equipment and incidentals as may be necessary for the expeditious and proper execution of the Project.

**ARTICLE II - ENGINEER** - The City Engineer shall mean the Director of Public Works, or his authorized representative will act as engineer in connection with completion of the Project in accordance with the Contract Documents.

**ARTICLE III - CONTRACT TIME** - The work will commence and finish in accordance with the Notice to Proceed and shall be completed by June 1, 2014.

**ARTICLE IV - CONTRACT PRICE** - Owner shall pay Contractor for performance of the work in accordance with the Contract Documents.

**ARTICLE V - PAYMENT** - Partial payments will be made in accordance with the percentage of work completed at time of payment application. Upon final acceptance of the work and settlement of all claims, Owner shall pay the Contractor the unpaid balance of the Contract Price, subject to additions and deductions provided for in the Contract Documents.

**ARTICLE VI - RETAINAGE** – To insure the proper performance of this Contract, the Owner shall retain ten percent of the Contract Price as specified in the Contract Documents.

**ARTICLE VII - LIQUIDATED DAMAGES** - In event the Contractor fails to successfully execute the work within the specified contract time the Owner shall assess the Contractor liquidated damages in the amount of **one hundred dollars (\$100)** for each calendar day beyond the specified completion date for each section of work. Liquidated damages shall be deducted from the Contract Price prior to final payment of the Contractor.

**CONTRACT AGREEMENT** (continued)

**ARTICLE VIII – CONTRACT DOCUMENTS** – The Contract Documents which comprise the contract between Owner and Contractor are attached hereto and made a part hereof and consist of the following:

- 8.1 This Agreement
- 8.2 Contractor’s Bid and Bonds
- 8.3 Notice of Award, Notice to Proceed
- 8.4 Instruction to Bidders
- 8.5 General Requirements, Control of Work, Temporary Facilities, Measurement and Payment, Standard Specifications
- 8.6 Insurance Requirements
- 8.7 Specifications
- 8.8 Drawings: “Prescott Park Pavilion Building” by McHenry Architecture
- 8.9 Special Provisions
- 8.10 Any modifications, including change orders, duly delivered after execution of this Agreement.

**ARTICLE IX – TERMINATION FOR DEFAULT** – Should contractor at any time refuse, neglect, or otherwise fail to supply a sufficient number or amount of properly skilled workers, materials, or equipment, or fail in any respect to prosecute the work with promptness and diligence, or fail to perform any of its obligations set forth in the Contract, Owner may, at its election, terminate the employment of Contractor, giving notice to Contractor in writing of such election, and enter on the premises and take possession, for the purpose of completing the work included under this Agreement, of all the materials, tools and appliances belonging to Contractor, and to employ any other persons to finish the work and to provide the materials therefore at the expense of the Contractor.

**ARTICLE X – INDEMNIFICATION OF OWNER** – Contractor will indemnify Owner against all suits, claims, judgments, awards, loss, cost or expense (including without limitation attorneys’ fees) arising in any way out of the Contractor’s negligent performance of its obligations under this Contract. Contractor will defend all such actions with counsel satisfactory to Owner at its own expense, including attorneys’ fees, and will satisfy any judgment rendered against Owner in such action.

**ARTICLE XI – PERMITS** – The Contractor will secure at its own expense, all permits and consents required by law as necessary to perform the work and will give all notices and pay all fees and otherwise comply with all applicable City, State, and Federal laws, ordinances, rules and regulations.

**ARTICLE XII – INSURANCE** – The Contractor shall secure and maintain, until acceptance of the work, insurance with limits not less than those specified in the Contract.



**ARTICLE XIII – MISCELLANEOUS –**

- A. Neither Owner nor Contractor shall, without the prior written consent of the other, assign, sublet or delegate, in whole or in part, any of its rights or obligations under any of the Contract Documents; and, specifically not assign any monies due, or to become due, without the prior written consent of Owner.
- B. Owner and Contractor each binds himself, his partners, successors, assigns and legal representatives, to the other party hereto in respect to all covenants, agreements and obligations contained in the Contract Documents.
- C. The Contract Documents constitute the entire Agreement between Owner and Contractor and may only be altered amended or repealed by a duly executed written instrument.
- D. The laws of the State of New Hampshire shall govern this Contract without reference to the conflict of law principles thereof.
- E. Venue for any dispute shall be the Rockingham County Superior Court unless the parties otherwise agree.

IN WITNESS WHEREOF, the parties hereunto executed this  
AGREEMENT the day and year first above written.

**BIDDER:**

BY: \_\_\_\_\_

TITLE: \_\_\_\_\_

**CITY OF PORTSMOUTH, N.H.**

BY: \_\_\_\_\_

John P. Bohenko

TITLE: City Manager

**NOTICE OF INTENT TO AWARD**

Date:

To:

IN AS MUCH as you were the low responsible bidder for work entitled:

<b>Prescott Park Pavilion Building 2013</b>
---

You are hereby notified that the City intends to award the above referenced project to you.

Immediately take the necessary steps to execute the Contract and to provide required bonds and proof of insurance within ten (10) calendar days from the date of this Notice.

The City reserves the right to revoke this Notice if you fail to take the necessary steps to execute this Contract.

City of Portsmouth  
Portsmouth, New Hampshire

Judie Belanger,  
Finance Director

NOTICE TO PROCEED

DATE:

**Prescott Park Pavilion Building 2013**

TO:

YOU ARE HEREBY NOTIFIED TO COMMENCE WORK IN ACCORDANCE  
WITH THE AGREEMENT DATED, \_\_\_\_\_  
WORK SHALL BE COMPLETED PRIOR TO \_\_\_\_\_.

CITY OF PORTSMOUTH, N.H.

\_\_\_\_\_  
BY: \_\_\_\_\_

TITLE: Public Works Director

ACCEPTANCE OF NOTICE

RECEIPT OF THE ABOVE NOTICE TO  
PROCEED IS HEREBY ACKNOWLEDGED BY

\_\_\_\_\_  
This the \_\_\_\_\_ day of \_\_\_\_\_ 20\_\_

By: \_\_\_\_\_

Title: \_\_\_\_\_

**CHANGE ORDER**

---

Change Order Number:

Date of Issuance:

Owner: CITY OF PORTSMOUTH, N.H

Contractor:

---

You are directed to make the following changes in the  
Contract Documents:

Purpose of Change Order:

Attachments:

---

CHANGE IN CONTRACT PRICE

CHANGE IN CONTRACT TIME

Original Contract Price:  
\$

Original Completion Date:

---

Contract Price prior to this  
Change Order:  
\$

Contract Time prior to this  
Change Order:  
days

---

Net Increase of  
this Change Order:  
\$

Net Increase of  
this Change Order:  
days

---

Contract Price with all  
approved Change Orders:  
\$

Contract Time with all  
approved Change Orders:  
days

---

RECOMMENDED:

APPROVED:

APPROVED:

by \_\_\_\_\_ by \_\_\_\_\_ by \_\_\_\_\_ by \_\_\_\_\_

PW Director

City Finance

City Manager

Contractor

**PERFORMANCE BOND**

(This format provided for convenience, actual Performance Bond is acceptable in lieu, if compatible)

Bond Number \_\_\_\_\_

**KNOW ALL MEN BY THESE PRESENTS**

that \_\_\_\_\_ as principal, hereinafter called Contractor, and \_\_\_\_\_ (Surety Company) a [corporation] organized and existing under the laws of the State of \_\_\_\_\_ and authorized to do business in the State of New Hampshire as surety, hereinafter called Surety, are held and firmly bound unto the City of Portsmouth, N.H., hereinafter called Owner, in the amount of \_\_\_\_\_ Dollars (\$ \_\_\_\_\_), for the payment whereof Contractor and Surety bind themselves, their heirs, executors, administrators, successors and assigns, jointly and severally, firmly by these presents. WHEREAS, Contractor has by written agreement dated \_\_\_\_\_ entered into a contract with Owner for Prescott Park Pavilion 2013 on behalf of the City of Portsmouth, 1 Junkins Avenue, Portsmouth, N.H. 03801; which contract is by reference made a part hereof, and is hereinafter referred to as the Contract.

NOW, THEREFORE, THE CONDITION OF THIS OBLIGATION is such that if the Contractor shall well and faithfully do and perform the things agreed by him to be done and performed, according to the terms of said Contract and such alterations as may be made in said Contract during progress work, and shall further indemnify and save harmless the said Owner in accordance with the Contract, and shall remedy without cost to the Owner any defect which may develop within one year from the time of completion and acceptance of the work.

The Surety hereby waives notice of any alteration in work or extension of time made by the Owner or any of its agents or representatives.

Whenever Contractor shall be, and declared by Owner to be, in default under the Contract, the Owner having performed Owner's obligations thereunder, the Surety may promptly remedy the default, or shall promptly:

- (1) Complete the Contract in accordance with its terms and conditions, or
- (2) Obtain a bid or bids for submission to the Owner for completing the Contract in accordance with its terms and conditions, and upon determination by Owner and Surety of the lowest responsible Bidder, arrange for a contract between such Bidder and Owner and make available as work progresses (even though there should be a default or a succession of defaults under the contract of completion arranged under this paragraph) sufficient funds to pay the cost of completion less the balance of the contract price; but not exceeding, including other costs and damages for which the Surety may be liable hereunder, the amount set forth in the first paragraph hereof. The term "balance of the contract price", as used in this paragraph, shall mean the total amount payable by the Owner to Contractor under the Contract and any amendments thereto, less the amount paid by Owner to Contractor.

Any suit under this bond must be instituted before the expiration of (2) years from the date on which final payment under the contract falls due.

**PERFORMANCE BOND** (continued)

No right of action shall accrue on this bond to or for the use of any person or corporation other than the Owner named herein or the heirs, executors, administrators or successors of Owner.

Signed and sealed this \_\_\_\_\_ day of \_\_\_\_\_

A.D., 20\_\_ .

In the presence of:

\_\_\_\_\_  
(Witness)                      (Principal) (Seal)      BY: \_\_\_\_\_

\_\_\_\_\_  
(Surety Company)

\_\_\_\_\_  
(Witness)                      (Title) (Seal)      BY: \_\_\_\_\_

**Note:**

If the Principal (Contractor) is a partnership, the Bond should be signed by each of the partners.

If the Principal (Contractor) is a corporation, the Bond should be signed in its correct corporate name by its duly authorized Officer or Officers.

If this bond is signed on behalf of the Surety by an attorney-in-fact, there should be attached to it a duly certified copy of his Power of Attorney showing his authority to sign such Bonds.

There should be executed an appropriate number of counterparts of the bond corresponding to the number of counterparts of the Agreement.

**LABOR AND MATERIAL PAYMENT BOND**

(This format provided for convenience, actual Labor and Material Bond is acceptable in lieu, if compatible)

Bond Number \_\_\_\_\_

KNOW ALL MEN BY THESE PRESENTS:

that \_\_\_\_\_

as Principal, hereinafter called Contractor, and \_\_\_\_\_ (Surety Company) a corporation organized and existing under the laws of the State of

\_\_\_\_\_ and authorized to do business in the State of New Hampshire hereinafter called Surety, are held and firmly bound unto the City of Portsmouth, N.H. Obligee, hereinafter called Owner, for the use and benefit of claimants as herein below defined, in the

amount of \_\_\_\_\_ Dollars (\$ \_\_\_\_\_), for the payment whereof Principal and Surety bind themselves, their heirs, executors, administrators, successors and assigns, jointly and severally, firmly by these presents.

WHEREAS, Principal has by written agreement dated \_\_\_\_\_ entered into a contract with Owner for \_\_\_\_\_ in accordance with drawings and specifications prepared by McHenry Architecture on behalf of the City of Portsmouth, 1 Junkins Avenue, Portsmouth, N.H. 03801; which contract is by reference made a part hereof, and is hereinafter referred to as the Contract.

NOW, THEREFORE, THE CONDITION OF THIS OBLIGATION is such that the Principal shall promptly make payment to all claimants as hereinafter defined, for all labor and material used or reasonably required for use in the performance of the Contract and for the hire of all equipment, tools, and all other things contracted for or used in connection therewith, then this obligation shall be void, otherwise it shall remain in full force and effect, subject however, to the following conditions:

(1) A claimant is defined as one having a direct contract with the Principal or, with a subcontractor of the Principal for labor, material, equipment, or other things used or reasonably required for use in the performance of the Contract. "Labor and material" shall include but not be limited to that part of water, gas, power, light, heat, oil and gasoline, telephone service or rental of equipment applicable to the Contract.

(2) The above named Principal and Surety hereby jointly and severally agree with the Owner that every claimant as herein defined, who has not been paid in full before the expiration of a period of ninety (90) days after the date on which the last of such claimant's work or labor was done or performed, or materials were furnished by such a claimant, may sue on this bond for the use of such claimant, prosecute the suit by final judgment for such sum or sums as may be justly due claimant, and have execution thereon. The Owner shall not be liable for the payment of any such suit or any costs or expenses of any such suit, and principal and surety shall jointly and severally indemnify, defend and hold the Owner harmless for any such suit, costs or expenses.

(3) No suit or action shall be commenced hereunder by any claimant:

**LABOR AND MATERIAL PAYMENT BOND** (continued)

(a) Unless Claimant, other than one having a direct contract with the Principal, shall have given notice to all the following:

The Principal, the Owner and the Surety above named, within six (6) calendar months after such claimant did or performed the last of the work or labor, or furnished the last of the materials for which said claim is made, stating with substantial accuracy the amount claimed and the name of the party to whom the materials were furnished, or for whom the work or labor was done or performed. Such notice shall be served by mailing the same by registered mail or certified mail, postage prepaid, in an envelope addressed to the Principal, Owner, and Surety, at any place where an office is regularly maintained for the transaction of business, or served in any manner in which legal process may be served in the State of New Hampshire save that such service need not be made by a public officer.

(b) After the expiration of one (1) year following the date on which Principal ceased all work on said contract, it being understood, however, that if any limitation embodied in this bond is prohibited by any law controlling the construction hereof, such limitation shall be deemed to be amended so as to be equal to the minimum period of limitation permitted by such law.

(c) Other than in a State court of competent jurisdiction in and for the county or other political subdivision of the State in which the project, or any part thereof, is situated, or in the United States District Court for the district in which the project, or any part thereof, is situated, and not elsewhere. (4) The amount of this bond may be reduced by and to the extent of any payment of payments made in good faith hereunder, inclusive of the payment by Surety of mechanics' liens which may be filed on record against said improvement, whether or not claim for the amount of such lien by presented under and against this bond.

Signed and sealed this \_\_\_\_\_ day of \_\_\_\_\_, 20\_\_\_\_. In the presence of:

\_\_\_\_\_  
(Witness) BY: \_\_\_\_\_  
(Principal) (Seal)

\_\_\_\_\_  
(Surety Company)

\_\_\_\_\_  
(Witness) BY: \_\_\_\_\_  
(Title) (Seal)

Note:

If the Principal (Contractor) is a partnership, the Bond should be signed by each of the partners.

If the Principal (Contractor) is a corporation, the Bond should be signed in its correct corporate name by its duly authorized Officer or Officers.

If this bond is signed on behalf of the Surety by an attorney-in-fact, there should be attached to it a duly certified copy of his Power of Attorney showing his authority to sign such Bonds.

There should be executed an appropriate number of counterparts of the bond corresponding to the number of counterparts of the Agreement.



## MAINTENANCE BOND

At the Owner's election, a maintenance bond may be substituted for retainage at the completion of the project. If the Owner permits a maintenance bond, it shall be in the amount of **Twenty Percent (20%)** of the contract price with a corporate surety approved by the Owner. Such bond shall be provided at the time of Contract completion and shall guarantee the repair of all damage due to faulty materials or workmanship provided or done by the Contractor. This guarantee shall remain in effect for a period of one year after the date of final acceptance of the job by the Owner.

**CONTRACTOR'S AFFIDAVIT**

STATE OF \_\_\_\_\_:

COUNTY OF \_\_\_\_\_:

Before me, the undersigned, a \_\_\_\_\_  
(Notary Public, Justice of the Peace)

in and for said County and State personally appeared, \_\_\_\_\_  
(Individual, Partner, or duly authorized representative of Corporate)

who, being duly sworn, according to law deposes and says that the cost of labor, material, and equipment and outstanding claims and indebtedness of whatever nature arising out of the performance of the Contract between

CITY OF PORTSMOUTH, NEW HAMPSHIRE

and \_\_\_\_\_  
(Contractor)

of \_\_\_\_\_

Dated: \_\_\_\_\_

has been paid in full for Construction of: **Prescott Park Pavilion 2013**

\_\_\_\_\_  
(Individual, Partner, or  
duly authorized  
representative of  
Corporate Contractor)

Sworn to and subscribed  
before me this \_\_\_\_\_ day  
of \_\_\_\_\_ 20\_\_\_\_

\_\_\_\_\_

**CONTRACTOR'S RELEASE**

KNOW ALL MEN BY THESE PRESENTS that

I, \_\_\_\_\_ {insert name},  
in my capacity as \_\_\_\_\_ {insert title}  
of \_\_\_\_\_ {insert name of Contractor}

agrees that upon receipt of the sum of \$\_\_\_\_\_ from the CITY OF  
PORTSMOUTH NEW HAMPSHIRE as final and completed payment for the construction of:  
\_\_\_\_\_ Prescott Park Pavilion 2013

do hereby on behalf of \_\_\_\_\_ {name of Contractor} and its  
successors and assigns release, quit-claim and forever discharge the City of Portsmouth, New  
Hampshire, its successors and assigns, of and from all claims and demands arising from or in  
connection with the construction of the above-referenced project and the contract dated  
\_\_\_\_\_. All claims and demands shall include without limitation all actions, causes,  
suits, debts, dues, duties, sums of money, accounts, reckonings, bonds, bills, specifications,  
covenants, contracts, agreements, promises, damages and judgments whatsoever in law or equity  
against the City of Portsmouth, New Hampshire which Contractor ever had, now has or may  
have, for, upon or by reason of any matter, cause, or thing whatsoever; from the beginning of  
record time to the date of these presents.

IN WITNESS WHEREOF,

Witness

Contractor:

\_\_\_\_\_  
print name : \_\_\_\_\_

By: \_\_\_\_\_  
Its Duly Authorized \_\_\_\_\_

Dated: \_\_\_\_\_

## GENERAL REQUIREMENTS

### **SCOPE OF WORK**

#### 1. INTENT OF CONTRACT

The intent of the Contract is to provide for the construction and completion in every detail of the work described. The Contractor shall furnish all labor, materials, equipment, tools, transportation and supplies required to complete the work in accordance with the terms of the Contract. The Contractor shall be required to conform to the intent of the plans and specifications. No extra claims shall be allowed for portions of the work not specifically addressed in the plans and specifications but required to produce a whole and complete project, such work will be considered subsidiary to the bid items.

#### 2. INCIDENTAL WORK

Incidental work items for which separate payment is not measured includes, but is not limited to, the following items:

- a. General clean up
- b. Signs & barricades
- c. Mobilization/Demobilization
- d. Restoration of property
- e. Cooperation with other contractors, abutters and utilities.
- f. Clearing, grubbing and stripping
- g. Steel and/or wood sheeting as required.
- h. Accessories and fasteners or components required to make items complete and functional.
- i. Maintaining current EPA standards and practices when removing asbestos.

#### 3. ALTERATION OF PLANS OR OF CHARACTER OF WORK

The Owner reserves the right, without notice to Surety, to make such alterations of the plans or of the character of the work as may be necessary or desirable to complete fully and acceptably the proposed construction; provided that such alterations do not increase or decrease the contract cost. Within these cost limits, the alterations authorized in writing by the Owner shall not impair or affect any provisions of the Contract or bond and such increases or decreases of the quantities as a result from these alterations or deletions of certain items, shall not be the basis of claim for loss or for anticipated profits by the contractor. The contractor shall perform the work as altered at the contract unit price or prices.

#### 4. EXTRA WORK ITEMS

Extra work shall be performed by the Contractor in accordance with the specifications and as directed, and will be paid for at a price as provided in the Contract documents or if such pay items are not applicable than at a price negotiated between the contractor and the Owner or at the unit bid price. If no agreement can be negotiated, the Contractor will accept as payment for extra work, cost plus 15% (overhead & profit). Costs shall be substantiated by invoices and certified payroll. If the Owner determines that extra work is to be performed, a change order will be issued.

## 5. CHANGE ORDERS

The Owner reserves the right to issue a formal change order for any increase, decrease, deletion, or addition of work or any increase in contract time or price. The contractor shall be required to sign the change order and it shall be considered as part of the Contract documents.

## 6. FINAL CLEANING UP

Before acceptance of the work, the contractor shall remove from the site all machinery, equipment, surplus materials, rubbish, temporary buildings, barricades and signs. All parts of the work shall be left in a neat and presentable condition. On all areas used or occupied by the contractor, regardless of the contract limits, the bidder shall clean-up all sites and storage grounds.

The items prescribed herein will not be paid for separately, but shall be paid for as part of the total contract price.

## 7. ERRORS AND INCONSISTENCY IN CONTRACT DOCUMENTS

Any provisions in any of the Contract Documents that may be in conflict with the paragraphs in these General Requirements shall be subject to the following order of precedence for interpretation.

1. Drawings, Technical Specifications, and Special Provisions will govern General Requirements.

## CONTROL OF WORK

### 1. AUTHORITY OF ENGINEER

(a) All work shall be done under supervision of the City Engineer and to his satisfaction. The City Engineer will decide all questions which may arise as to the quality and acceptability of materials furnished and work performed and as to the rate of progress of the work; all questions that may arise as to the interpretation of the plans and specifications; and all questions as to the acceptable fulfillment of the Contract by the Contractor.

(b) The City Engineer will have the authority to suspend the work wholly or in part for such periods as he may deem necessary due to the failure of the Contractor to correct conditions unsafe for workers or the general public; for failure to carry out provisions of the Contract; for failure to carry out orders; for conditions considered unsuitable for the prosecution of the work, including unfit weather; or for any other condition or reason deemed to be in the public interest. The Contractor shall not be entitled any additional payments arising out of any such suspensions.

(c) The Owner reserves the right to demand a certificate of compliance for a material or product used on the project. When the certificate of compliance is determined to be unacceptable to the City Engineer the Contractor may be required to provide engineering and testing services to guarantee that the material or product is suitable for use in the project, at its expense (see Sample of Certificate of Compliance).

### 2. PROTECTION AND RESTORATION OF PROPERTY AND LANDSCAPES

(a) The Contractor shall use every precaution to prevent injury or damage to wires, poles, or other property of public utilities; trees, shrubbery, crops, and fences along and adjacent to the right-of-way, all underground structures such as pipes and conduits, within or outside of the right-of-way; and the Contractor shall protect and carefully preserve all property marks until an authorized agent has witnessed or otherwise referenced their location.

(b) The Contractor shall be responsible for all damage or injury to property of any character, during the prosecution of the work, resulting from any act, omission, neglect, or misconduct in his manner or method of executing the work, or at any time due to defective work or materials, and said responsibility will not be released until the project shall have been completed and accepted.

(c) When or where any direct or indirect damage or injury is done to public or private property by or on account of any act, omission, neglect, or misconduct in the execution of the work, or as a result of the failure to perform work by the Contractor, the Contractor shall restore, at its own expense, such property to a condition similar or equal to that existing before such damage or injury was done, by repairing rebuilding, or otherwise restoring as may be directed, or the Contractor shall make good such damage or injury in an acceptable manner.

(d) The Contractor shall paint with tree paint all scars made on fruit or ornamental trees by equipment, construction operations, or the removal of limbs larger than one inch in diameter. Damaged trees must be replaced if so determined by the City Arborist, in his or her sole discretion.

(e) If the Contractor fails to repair, rebuild or otherwise restore such property as may be deemed necessary, the Owner, after 48 hours notice, may proceed to do so, and the cost thereof may be deducted from any money due or which may become due the Contractor under the contract.

## **CONTROL OF WORK** (continued)

(f) It is the intent of the Parties that the Contractor preserves, to as great an extent as possible, the historic & natural features of the site.

(g) The Contractor shall follow all US Environmental Protection Agency's current standards for asbestos removals during this project. This includes protection of area within the existing building as required by the US EPA standards. A copy of the contractor's asbestos removals certification shall be provided to the Owner prior to start of construction.

### **3. MAINTENANCE DURING CONSTRUCTION**

The Contractor shall maintain the work during construction and until the project is accepted. This maintenance shall constitute continuous and effective work prosecuted day by day, with adequate equipment and workers to ensure that the structure is kept in satisfactory conditions at all times.

### **4. SAFETY PRECAUTIONS**

Upon commencement of work, the Contractor shall be responsible for initiating, maintaining and supervising all safety precautions necessary to ensure the safety of employees on the site, other persons who may be affected thereby, including the public, and other property at the site or adjacent thereto. This includes meeting current EPA asbestos removal standards.

### **5. PERMITS**

It will be the responsibility of the Contractor to obtain all permits required for the operation of equipment in, or on, all city streets and public ways.

### **6. BARRICADES, WARNING SIGNS AND TRAFFIC OFFICERS**

(a) The Contractor shall provide, erect and maintain all necessary barricades, suitable and sufficient lights, danger signals, signs and other traffic control devices, and shall take all necessary precautions for the protection of the work and safety of the public. Roadway closed to traffic shall be protected by effective barricades. Obstructions shall be illuminated during hours of darkness. Suitable warning signs shall be provided to control and direct traffic in a proper manner, as approved by the engineer.

(b) The Contractor will be held responsible for all damage to the work from traffic, pedestrians, animals or any other cause due to lack of adequate controlling devices.

The work prescribed herein will not be paid for separately but will be paid for as part of the Contract Price unless specifically appearing as a bid item.

## INSURANCE REQUIREMENTS

Insurance shall be in such form as will protect the Contractor from all claims and liabilities for damages for bodily injury, including accidental death, and for property damage, which may arise from operations under this contract whether such operation by himself or by anyone directly or indirectly employed by him.

### AMOUNT OF INSURANCE

- A) Comprehensive General Liability:  
Bodily injury or Property Damage - \$2,000,000  
Per occurrence and general aggregate
- B) Automobile and Truck Liability:  
Bodily Injury or Property Damage - \$2,000,000  
Per occurrence and general aggregate  
  
Coverage requirements can be met with excess policies

Additionally, the Contractor shall purchase and maintain the following types of insurance:

- A) Full Workers Comprehensive Insurance coverage for all people employed by the Contractor to perform work on this project. This insurance shall at a minimum meet the requirements of the most current laws of the State of New Hampshire.
- B) Contractual Liability Insurance coverage in the amounts specified above under Comprehensive General Liability.
- C) Product and Completed Operations coverage to be included in the amounts specified above under Comprehensive General Liability.
- D) Builder's Risk in the amount of the contract.

### ADDITIONAL INSURED

All liability policies (including any excess policies used to meet coverage requirements) shall include the City of Portsmouth, New Hampshire as named Additional Insureds.

- 1) The contractor's insurance shall be primary in the event of a loss.
- 2) The Additional Insured endorsement must include language specifically stating that the entity is to be covered for all activities performed by, or on behalf of, the contractor, including the City of Portsmouth's general supervision of the contractor.
- 3) City of Portsmouth shall be listed as a Certificate Holder. The City shall be identified as follows:

City of Portsmouth  
Attn: Legal Department  
1 Junkins Avenue  
Portsmouth, NH 03801



## **TEMPORARY FACILITIES**

### **1. STORAGE FACILITIES**

(a) The Contractor shall not store materials or equipment in a public right-of-way beyond the needs of one working day. Equipment and materials shall be stored in a location approved by the Owner.

(b) The Contractor shall protect all stored materials from damage by weather or accident and shall insure adequate drainage at and about the storage location.

(c) Prior to final acceptance of the work all temporary storage facilities and surplus stored materials shall be removed from the site.

### **2. SANITARY FACILITIES**

The Owner shall provide the Contractor with reasonable access to toilet facilities for the use of the workers employed on the work.

### **3. WATER FACILITIES**

The Owner shall provide the Contractor with reasonable access to water facilities for construction operations.

### **4. TEMPORARY ELECTRICITY**

The Owner shall provide the Contractor with reasonable access to electrical power necessary for construction operation at the site.

## MEASUREMENT AND PAYMENT

### 1. MEASUREMENT OF QUANTITIES

- (a) All work completed under the contract will be measured according to the United States standard measure.
- (b) The method of measurement and computations to be used in determination of quantities of material furnished and of work performed under the contract will be those methods generally recognized as conforming to good engineering practice. Unless otherwise stated all quantities measured for payment shall be computed or adjusted for "in place" conditions.
- (c) Unless otherwise specified, longitudinal measurements for area computations will be made horizontally, and no deductions will be made for individual fixtures having an area of 9 square feet or less. Unless otherwise specified, transverse measurements for area computations will be the dimensions shown on the plans or ordered in writing.
- (d) Structures will be measured according to lines shown on the plans or as ordered unless otherwise provided for elsewhere in the specifications.
- (e) In computing volumes of excavation, embankment, and borrow, the average end area method will be used. Where it is impracticable to measure by the cross-section method, acceptable methods involving three-dimensional measurement may be used. When measurement of borrow in vehicles is permitted, the quantity will be determined as 80 percent of the loose volume.
- (f) In computing volumes of concrete, stone and masonry, the prismatic method will be used. The term "ton" will mean the short ton consisting of 2,000 pounds avoirdupois.
- (g) Except as specified below, all materials that are measured or proportioned by weight shall be weighed on scales which the Contractor has had sealed by the State or by a repairman registered by the Commissioner of Agriculture. All weighing shall be performed in a manner prescribed under the Rules and Regulations of the Bureau of Weights and Measures of the New Hampshire Department of Agriculture.
- (h) Weighing of materials on scales located outside New Hampshire will be permitted for materials produced or stored outside the state, when requested by the Contractor and approved. Out-of-state weighing in order to be approved, must be performed by a licensed public weigh master or a person of equal authority in the state concerned on scales accepted in the concerned state.
- (i) Each truck used to haul material being paid for by weight shall bear a plainly legible identification mark, and if required, shall be weighed empty daily at such times as directed.
- (j) When material is weighed, the individual weight slips, which shall be furnished by the Contractor, for trucks, trailers, or distributors, shall show the following information: the date; the project; the material or commodity; the dealer or vendor; the Contractor or Subcontractor; the location of the scales; the vehicle registration number or other approved legible identification mark; the tare and net weights, with gross weights when applicable; and the weigher's signature or his signed initials.
- (k) The right is reserved to weight any truck, trailer, or distributor, at locations designated, before and after making deliveries to the project.

## **MEASUREMENT AND PAYMENT (continued)**

(l) Bituminous materials will be measured by the gallon or ton.

(m) When material is specified to be measured by the cubic yard but measurement by weight is approved, such material may be weighed and the weight converted to cubic yards for payment purposes. Necessary conversion factors will be determined by the Owner.

(n) The term "lump sum" when used as an item of payment will mean complete payment for the work described in the item.

(o) When a complete structure or structural unit (in effect, "lump sum" work) is specified as the unit of measurement, the unit will be construed to include all necessary fittings and accessories, so as to provide the item complete and functional. Except as may be otherwise provided, partial payments for lump sum items will be made approximately in proportion to the amount of the work completed on those items.

(p) Material wasted without authority will not be included in the final estimate.

## **2. SCOPE OF PAYMENT**

(a) The Contractor shall receive and accept compensation provided for in the contract as full payment for furnishing all materials and for performing all work under the contract in a complete and acceptable manner and for all risk, loss, damage or expense of whatever character arising out of the nature of the work or the prosecution thereof.

(b) The Contractor shall be liable to the Owner for failure to repair, correct, renew or replace, at his own expense, all damage due or attributable to defects or imperfections in the construction which defects or imperfections may be discovered before or at the time of the final inspection and acceptance of the work.

(c) No monies, payable under the contract or any part thereof, shall become due or payable if the Owner so elects, until the Contractor shall satisfy the Owner that the Contractor has fully settled or paid all labor performed or furnished for all equipment hired, including trucks, for all materials used, and for fuels, lubricants, power tools, hardware and supplies purchased by the Contractor and used in carrying out said contract and for labor and parts furnished upon the order of said Contractor for the repair of equipment used in carrying out said contract; and the Owner, if he so elects, may pay any and all such bills, in whole or in part.

## **3. PAYMENT PROCEDURES**

Submit Application for Payment after completion of Project closeout procedures with release of liens and supporting documentation. Include consent of surety to final payment and insurance certificates.

## **4. COMPENSATION FOR ALTERED QUANTITIES**

(a) Except as provided for under the particular contract item, when the accepted quantities of work vary from the quantities in the bid schedule the Contractor shall accept as payment in full, so far as contract items are concerned, at the original contract unit prices for the accepted quantities of work done. No allowance will be made for any increased expense, loss of expected reimbursement, or loss of anticipated profits suffered or claimed by the Contractor resulting either directly from such alterations or indirectly from unbalanced allocation among the contract items of overhead expense on the part of the Bidder and subsequent loss of expected reimbursements therefore or from any other cause.

## MEASUREMENT AND PAYMENT (continued)

(b) Extra work performed will be paid for at the contract bid prices or at the price negotiated between the Owner and the Contractor if the item was not bid upon. If no agreement can be negotiated, the Contractor will accept as payment for extra work, cost plus 15% (overhead and profit). Costs shall be substantiated by invoices and certified payroll.

### 5. PARTIAL PAYMENTS

Partial payments will be made on a monthly basis during the contract period, and based on the percentage of work completed. From the total amount ascertained as payable, an amount equivalent to ten percent (10%) of the whole will be deducted and retained by the Owner until such time as the work receives final acceptance.

### 6. FINAL ACCEPTANCE

Upon due notice from the Contractor of presumptive completion of the entire project, the Owner and City Engineer will make an inspection. If all construction provided for and contemplated by the contract is found complete to their satisfaction, this inspection shall constitute the final inspection and the Owner or City Engineer will make the final acceptance and notify the Contractor in writing of this acceptance as of the date of the final inspection.

If, however, the City Engineer's inspection discloses any work in whole or in part, as being unsatisfactory, the Engineer will give the Contractor the necessary instructions for correction of such work, and the Contractor shall immediately comply with and execute such instructions. Upon correction of the work, another inspection will be made which shall constitute the final inspection provided the work has been satisfactorily completed. In such event, the City Engineer will make the final acceptance and notify the Contractor in writing of this acceptance as of the date of final inspection.

### 7. ACCEPTANCE AND FINAL PAYMENT

(a) When the project has been accepted and upon submission by the Contractor of all required reports, completed forms and certifications, the Owner will review the final estimate of the quantities of the various classes of work performed. The Contractor may be required to certify that all bills for labor and material used under this contract have been paid.

(b) The Contractor shall file with the Owner any claim that the Contractor may have regarding the final estimate at the same time the Contractor submits the final estimate. Failure to do so shall be a waiver of all such claims and shall be considered as acceptance of the final estimate. From the total amount ascertained as payable, an amount equal to ten percent (10%) of the whole will be deducted and retained by the Owner for the guaranty period. This retainage may be waived, at the discretion of the City, provided the required Maintenance Bond has been posted. After approval of the final estimate by the Owner, the Contractor will be paid the entire sum found to be due after deducting all previous payments and all amounts to be retained or deducted under the provisions of the contract.

(c) All prior partial estimates and payments shall be subject to correction in the final estimate and payment.

## MEASUREMENT AND PAYMENT (continued)

### 8. GENERAL GUARANTY AND WARRANTY OF TITLE

(a) Neither the final certification of payment nor any provision in the contract nor partial or entire use of the improvements embraced in this Contract by the Owner or the public shall constitute an acceptance of work not done in accordance with the Contract or relieve the Contractor of liability in respect to any express or implied warranties or responsibility for faulty materials or workmanship. The Contractor shall promptly remedy any defects in the work and pay for any damage to other work resulting there from which shall appear within a period of twelve (12) months from the date of final acceptance of the work. The Owner will give notice of defective materials and work with reasonable promptness.

(b) No material, supplies or equipment to be installed or furnished under this Contract shall be purchased subject to any chattel mortgage or under a conditional sale, lease purchase or other agreement by which an interest therein or in any part thereof is retained by the Seller or supplier. The Contractor shall warrant good title to all materials, supplies and equipment installed or incorporated in the work and upon completion of all work, shall deliver the same together with all improvements and appurtenances constructed or placed thereon by him to the Owner free from any claims, liens or charges. Neither the Contractor nor any person, firm or corporation furnishing any material or labor for any work covered by this Contract shall have the right to a lien upon any improvements or appurtenances thereon.

Nothing contained in this paragraph, however, shall defeat or impair the right of persons furnishing materials or labor to recover under any bond given by the Contractor for their protection or any rights under any law permitting such persons to look to funds due the Contractor in the hands of the Owner. The provisions of this paragraph shall be inserted in all subcontractors and material contracts and notice of its provisions shall be given to all persons furnishing materials for the work when no formal contract is entered into for such materials.

(c) At completion of project, Contractor to provide to Owner, written guarantee of one (1) year Workmanship warranty; and one (1) year Manufacturer's warranty on burner components and ten (10) year Manufacturer's warranty on pressure vessels.

### 9. NO WAIVER OF LEGAL RIGHTS

(a) Upon completion of the work, the Owner will expeditiously make final inspection and notify the Contractor of acceptance. Such final acceptance, however, shall not preclude or stop the Owner from correcting any measurement, estimate, or certificate made before or after completion of the work, nor shall the Owner be precluded or be stopped from recovering from the Contractor or his Surety, or both, such overpayment as it may sustain by failure on the part of the Contractor to fulfill his obligations under the contract. A waiver on the part of the Owner of any breach of any part of the contract shall not be held to be a waiver of any other or subsequent breach.

(b) The Contractor, without prejudice to the Contract shall be liable to the terms of the Contract, shall be liable to the Owner for latent defects, fraud or such gross mistakes as may amount to fraud, and as regards the Owner's right under any warranty or guaranty.

### 10. TERMINATION OF CONTRACTOR'S RESPONSIBILITY

Termination of Contractor's responsibilities will occur whenever the improvement provided for by the Contract shall have been completely performed on the part of the Contractor and all parts of the work have been released from further obligations except as set forth in his bond and as provided in Section 8 above.

## **SHOP DRAWINGS**

The Contractor shall submit working and detail drawings, well in advance of the work, to the City's Consulting Architect for review.

The Contractor's drawings shall consist of shop detail, erection and other working plans showing dimensions, sizes and quality of material, details and other information necessary for the complete fabrication and erection of the pertinent work.

The Contractor shall submit two sets of drawings to the City's Consulting Architect, and one set of drawings to the Owner for review.

Prior to the approval of the drawings, any work done or materials ordered for the work involved shall be at the Contractor's risk.

One set of the drawings will be returned to the Contractor approved or marked with corrections to be made by the City's Consulting Architect. After approval has been given, the Contractor shall supply the City's Consulting Architect with two sets of the revised detail working drawings.

The City's Consulting Architect's approval of the Contractor's working drawings will not relieve the Contractor from responsibility for errors in dimensions or for incorrect fabrication processes, or from responsibility to complete the contract work.

**SPECIAL CONDITIONS  
&  
CRITICAL TIMELINES**

**REQUIRED DEADLINES**

The City has made certain representations to the residents, Prescott Park staff, and stakeholders of this project. A very important part of this project will be meeting certain goals by certain dates. The following criteria and dates are crucial to the success of this project.

The Pavilion must be finished by June 1, 2014 in order for the Prescott Park Arts Festival to commence activities for the 2014 performance season.

Failure to complete by this date will result in liquidated damages of \$100.00 per day.

There will no contractor parking permitted in the Park. Overflow parking for other than deliveries shall be on Water Street, Mechanic Street, or on Pierce Island.

Care must be taken to protect the gated entrance to the site off Marcy Street. Any damage to Park infrastructure will be repaired by the Contractor at their own expense.

Dust and mud must be controlled at all times to protect the residents, tourists, and pedestrian public.

The project site must be kept clean and passable on nights and weekends with gravel areas watered and kept dust free with calcium chloride, especially on Fridays and before holidays.

The white fence surrounding the formal garden must be protect with tarps during construction.

Trees in Prescott park shall be protected at all times.

Contractor shall follow the noise ordinance at all times. Construction noise is permitted only on week days between the hours of 7AM to 6PM. There will no work on weekends or holidays.



# Prescott Park Pavilion Building

Project Manual

September 16, 2013

Prepared by

**McHENRY ARCHITECTURE**

4 Market Street

Portsmouth, New Hampshire



## PROJECT MANUAL CONTENTS

### PROJECT SUMMARY

### PROJECT DIRECTORY

### DRAWING LIST

### SPECIFICATION CONTENTS

---

#### PROJECT SUMMARY

Location:

105 Marcy Street, Portsmouth, NH 03801

Size:

2,408 Square Feet (SF)

Existing Building Renovation: 687 SF

First Floor Addition: 1,097 SF

Second Floor Addition: 624 SF

Description:

The project consists of renovating an existing concession stand and public restroom facility into a full service Kitchen. The first floor addition will house a larger Men's and Women's Bathroom with a total of 17 fixtures that includes a Family Bathroom and both wheelchair and ambulatory accessible compartments. The second floor addition will provide a space for much needed storage and mechanical equipment.

---

#### PROJECT DIRECTORY

Architecture:	McHenry Architecture PLLC	Portsmouth, New Hampshire
Principal:	Steven McHenry	Email- <a href="mailto:steve@mchenryarchitecture.com">steve@mchenryarchitecture.com</a>
Project Manager:	Jeremiah Johnson	Email- <a href="mailto:jeremiah@mchenryarchitecture.com">jeremiah@mchenryarchitecture.com</a>

**Civil Engineer:**

**Drew Vardakis**

CMA Engineers

35 Bow Street, Portsmouth, NH 03801

Phone-603.431.6196 Fax-603.431.5376

Email- [avardakis@cmaengineers.com](mailto:avardakis@cmaengineers.com)

**Mechanical, Electrical, and Plumbing Engineers:**

**Lee Consavage**

Seacoast Consulting Engineers, LLC

261 Jennie Lane, Eliot, ME 03903

Phone-207.370.7230

Email- [lee@seacoastengineers.com](mailto:lee@seacoastengineers.com)

---

## DRAWING LIST

### ARCHITECTURAL

T1 LIST OF DRAWINGS, ABBREVIATIONS, LEGEND, & GENERAL NOTES  
T2 CODE REVIEW, WALL TYPES, & MOUNTING HEIGHTS  
T3 SCHEDULES

A1 FLOOR PLANS & DEMOLITION PLAN  
A2 ROOF & KITCHEN EQUIPMENT PLAN  
A3 REFLECTED CEILING PLAN  
A4 ELEVATIONS  
A5 BUILDING SECTIONS  
A6 BUILDING SECTIONS  
A7 BUILDING SECTIONS  
A8 BUILDING SECTIONS  
A9 BUILDING SECTIONS  
A10 WALL SECTIONS  
A11 WALL SECTIONS

### CIVIL

C1 EXISTING CONDITIONS PLAN  
C2 PROPOSED SITE PLAN

### STRUCTURAL

S0.0 GENERAL STRUCTURAL NOTES  
S0.1 SCHEDULE OF SPECIAL INSPECTIONS  
S1.0 FOUNDATION PLAN  
S2.0 FLOOR AND ROOF FRAMING PLANS

### ELECTRICAL

E1 ELECTRICAL SYMBOLS, LEGEND, NOTES, LIGHTING SCHEDULE  
E1A SPECIFICATIONS, SCOPE OF WORK, UTILITY SERVICES RISER DIAGRAM  
E2 POWER, FIRE ALARM & TEL/DATA RISER DIAGRAMS, GROUNDING DIAGRAM  
E3 MECH. CIRCUIT SCHEDULES, TYPICAL DEVICE MOUNTING HEIGHTS DETAIL  
E4 PAVILION 1<sup>ST</sup> & 2<sup>ND</sup> FLOOR PLANS – POWER & TEL/DATA  
E5 PAVILION 1<sup>ST</sup> & 2<sup>ND</sup> FLOOR – RCP – LIGHTING  
E6 NOT ISSUED  
E7 PAVILION FIRE ALARM

### MECHANICAL

M1 FIRST, SECOND & ROOF PLANS & NOTES  
M2 VENTILATION DETAILS & SCHEDULES

### PLUMBING

P1.0 PLUMBING LEGENDS, ABBREVIATIONS, AND SCHEDULES  
P1.1 PLUMBING PLANS AND SCHEDULE  
P1.2 PLUMBING PLAN AND SPECIFICATIONS  
P1.3 PLUMBING PLAN AND RISER DIAGRAM

---

TABLE OF CONTENTS

		Page
DIVISION 01	GENERAL REQUIREMENTS	4
DIVISION 02	SITE WORK	5
	01569 Dig Safe	6
	02220 Excavation	8
	02229 Backfill and Compaction	12
	02370 Erosion Control	19
	02500 Sidewalks	24
	02551 Bituminous Pavement	25
	02552 Sawed Pavement	27
	02622 PVC Pipe and Fittings	28
	02625 Corrugated Polyethylene (CPE) Pipe and Fittings	32
	02626 Copper Service Pipe	36
	02630 Couplings, Connectors, Caps and Plugs	38
	02651 Final Sewer Testing	41
	02930 Loam and Seed	45
DIVISION 03	CONCRETE	57
	033000 Cast-In-Place Concrete	57
DIVISION 04	MASONRY	64
	042000 Unit Masonry	64
DIVISION 06	WOOD, PLASTICS AND COMPOSITES	75
	061000 Rough Carpentry	76
	061170 Wood Trusses	83
DIVISION 07	THERMAL AND MOISTURE PROTECTION	89
DIVISION 08	OPENINGS	90
DIVISION 09	FINISHES	90
DIVISION 10	SPECIALTIES	90
DIVISION 11	EQUIPMENT	90
DIVISION 22	PLUMBING	91
DIVISION 23	MECHANICAL	93
DIVISION 26	ELECTRICAL	93
SCHEDULES	Door Schedule	99
	Hardware Schedule	100
	Bathroom Fixture Schedule	101
	Room Finish Schedule	103

**DIVISION 1- GENERAL REQUIREMENTS**

- A. The contractor shall provide all labor, materials, transportation, tools, equipment, shop services, and related items required for the complete and proper shaping of the project work in conformance with the drawings and specifications. All work shall be performed in a near workmanlike manner, equal to the best in shop and field procedure. All materials shall be new unless otherwise stated. The contractor shall apply sustainable building practices wherever possible.
  - B. All work shall comply with all applicable federal, state, and local codes and ordinances, including the International Building Code (IBC), NFPA Life Safety Code, State Energy Code, and all other governing regulations (current editions).
  - C. The contractor shall secure and pay for all permits and inspections, and shall give all required notices to public agencies.
  - D. The contractor shall provide all public services required by the work.
  - E. The contractor shall carefully examine all contract documents. The contractor shall not take measurements off the drawings with a scale or ruler. Any discrepancies between either the drawings, specifications, and/or site conditions shall be brought to the attention of the architect, and any affected work shall not proceed without instructions from the architect. The architect shall not be liable for any unauthorized change to the project design.
  - F. The contractor shall be fully responsible for supervising all trades, coordinating the work done by all subcontractors, and expediting the work as a whole, allowing each trade reasonable opportunities for the installation of its work and for the storage and handling of its materials. The subcontractors shall also provide for all cutting, patching, and fitting that may be required in his/her work and shall make good after them, doing all patching, repairing and painting necessary to match adjacent surfaces.
  - G. The contractor shall provide allowances, where noted herein and not otherwise furnished, consistent with the quantity and application of the items indicated, stipulating each in the proposal. Adjustments will be made to the contract price upon calculating any differences between the actual material costs and the allowances.
  - H. The contractor shall provide submittals for product selection and approval by the architect and owner of all exterior and interior wall and floor finishes or prefinished materials, roofing, finishes, hardware, specialties, equipment, fixtures, etc. Maintenance instructions shall be submitted at the completion of the project.
  - I. The contractor shall fully and continuously protect all parts of the work from damage and vandalism, and shall also protect adjacent properties against damage from the construction process.
  - J. The contractor shall carry insurance against claims under workmen's compensation acts and against all other claims for damage, for personal injury or death, which may arise from the project operations.
  - K. The owner shall maintain fire insurance with extended coverage upon the entire structure during construction, the contractor being the payee for all such damage that requires repairing.
  - L. The subcontractors shall regularly keep the premises free from accumulations of waste materials and rubbish, removing same to a legal dump site. Any suitable materials shall be transported to an authorized recycling center. At the completion of the work, all interior spaces shall be left broom clean and all windows shall be washed.
  - M. The contractor guarantees that all labor and materials on this project shall be free from defects and agrees to make good and repair at no further expense, upon written request of the owner, all defects in the work within one year after final completion of the contract, except that all roofs shall be guaranteed for a period of 5 years after completion.
- These general requirements apply to all divisions of the specifications.
-

*DIVISION 2*  
**SITE WORK**

---

Scope of Work

Furnish, install and test all site work and appurtenant work in complete accordance with the Drawings and Specifications.

Contractor's Duties

Except as specifically noted, provide and pay for all labor, materials, equipment, tools, machinery, water, heat, other facilities and services necessary for proper execution and completion of the work.

Contents of Division

<u>Section No.</u>	<u>Section Title</u>
01569	Dig Safe
02220	Excavation
02229	Backfill and Compaction
02370	Erosion Control
02500	Sidewalks
02551	Bituminous Pavement
02552	Sawed Pavement
02622	PVC Pipe and Fittings
02625	Corrugated Polyethylene (CPE) Pipe and Fittings
02626	Copper Service Pipe
02630	Couplings, Connectors, Caps and Plugs
02651	Final Sewer Testing
02930	Loam and Seed
02940	Planting

*SECTION 01569*  
**DIG-SAFE**

---

PART 1 -- GENERAL

1.1 DESCRIPTION

- A. Contact Dig-Safe prior to performing any underground work.
- B. Meet all of the requirements, regulations, and laws concerning layout, notification, excavation, demolition, and explosive work.
- C. Meet the requirements of RSA 374:55.
- D. Contact City Water and Sewer Departments.

PART 2 -- PRODUCTS

(NOT PART OF THIS SECTION)

PART 3 -- EXECUTION

3.1 DIG-SAFE

- A. Dig-Safe shall be contacted a minimum of 72 hours prior to, but no more than 60 days before any underground work on public or private property is performed.
- B. All locations where underground work will be performed shall be marked-out prior to contacting the local Dig-Safe office.
- C. The local Dig-Safe office is at 331 Monvale Ave., Woburn, MA 01810. Their telephone number is 1-888-344-7233.
- D. The Contractor shall maintain the Dig-Safe number at the job site at all times. The number shall also be forwarded to the Owner.

3.2 OTHER AUTHORITIES

- A. The Contractor shall also contact the New Hampshire Public Utilities Commission in accordance with RSA 374:55 and local water and sewer authorities.
- B. These contacts shall also be made within the minimum and maximum notice periods as noted above for Dig-Safe.

### 3.3 EXCAVATION

- A. The Contractor shall take precautions not to damage utilities during prosecution of the work. If markings become damaged during prosecution of the work, the Contractor shall take ties to the marks.
- B. The Contractor shall maintain the marks for the duration of the project. Costs for remarking shall be paid by the Contractor at no additional cost to the Owner.

END OF SECTION

*SECTION 02220*  
**EXCAVATION**

---

PART 1 -- GENERAL

1.1 DESCRIPTION

A. Work Included:

1. Excavation work includes the removal of all subsurface materials necessary to install the facilities as designed.

1.2 JOB CONDITIONS

A. Utilities:

1. The information about known utilities was collected from the owning agency and may or may not have been supplemented by additional field survey or investigation.
2. The approximate locations of known buried and overhead utilities are shown on the Drawings. No guarantee is made as to the accuracy or correctness of the locations shown and to the completeness of the information given. The Contractor is responsible for confirming the location of utilities in the field prior to commencement of work.
3. Discontinue excavation by machinery when the excavation approaches pipes, conduits, or other underground structures of which the approximate locations are known. Use manual excavation methods to locate the utilities.
4. See Section 01569 – Dig-Safe for utility notification and marking requirements.

B. Existing Structures:

1. Perform excavation in such a manner that will prevent any possibility of undermining or disturbing existing structures, utilities, and work previously completed under this Contract.
2. Where existing buildings and other structures are in close proximity to the proposed construction, exercise extreme caution and utilize sheeting, bracing, and all other precautionary measures that may be required.

C. Repairing Damage: Repair all damage to existing utilities, structures, grassed, or paved areas which results from construction operations, at no additional cost to the Owner, to the complete satisfaction of the Owner, the Engineer, the utility company and the property owner.

D. Do not leave any trenches open overnight.

E. Erect a barrier around all structure excavations to prevent the entry of unauthorized individuals.



## PART 2 -- PRODUCTS

### 2.1 UNSUITABLE MATERIAL:

- A. If, in the opinion of the Engineer, the material encountered above the indicated grade as shown on the Drawings for excavation is unsuitable the Contractor shall remove the material to the widths and depths as directed by the Engineer. Replace this material as specified in Section 02229 – Backfill and Compaction.
- B. If, in the opinion of the Engineer, the material encountered at or below the indicated invert or grade shown on the Drawings for excavation is unstable (as determined by the Engineer), the Contractor shall remove the material. Replace this material with thoroughly compacted bank run gravel or crushed stone bedding material as shown on the Drawings, or as directed by the Engineer.
- C. Materials made unsuitable by Contractor's construction methods shall be suitably dried for reuse or removed from the site and replaced with suitable materials at no additional cost to the Owner. This material shall not be eligible for payment as unsuitable material.
- D. Materials determined unsuitable only due to moisture content shall be aerated and stockpiled and may be used as suitable backfill with the approval of the Engineer.

### 2.2 DISPOSAL OF EXCESS MATERIAL:

- A. All excess material that is, in the opinion of the Engineer, suitable shall remain the property of the Contractor.

### 2.3 DISPOSAL OF UNSUITABLE MATERIAL:

- A. All unsuitable material shall become the property of the Contractor.

### 2.4 DISPOSAL OF MATERIAL:

- A. Disposal of excess and unsuitable material shall be the responsibility of the Contractor.
- B. Dispose of suitable and unsuitable material in accordance with applicable environmental law, and if applicable, at the locations acceptable to the Owner and/or funding agency.
- C. The property owners where the material is disposed of shall sign a release form indemnifying the Owner, Engineer, and Contractor from any liability of disposal of the said material.

### 2.5 EMBANKMENT MATERIAL:

- A. Obtain prior approval and instructions from the Engineer prior to undertaking the excavation for pipe placement of any fill material that has been in an embankment for less than one year.
- B. Prior to the installation of any pipe, determine by means of compaction testing in accordance with Section 02229 – Backfill and Compaction that the base material is suitably dense to support the pipe.

## PART 3 -- EXECUTION

### 3.1 PERFORMANCE

- A. Structure Excavation:
  - 1. Amount of excavation:
    - a. Excavate areas large enough to provide suitable room for building or placing the structures.
    - b. The extent of open excavation shall be controlled by prevailing conditions.
- B. Trench Excavation:
  - 1. General:
    - a. Unless otherwise specifically directed or permitted by the Engineer, begin trench excavation at the low end of gravity lines and proceed upgrade.
    - b. Perform excavation for force mains and water mains in a logical sequence.
  - 2. Amount of Excavation:
    - a. Trench width: As shown on the Drawings.
    - b. Trench depth: As shown on the Drawings.
    - c. Open Excavation:
      - 1). The extent of open excavation shall be controlled by prevailing conditions.
      - 2). Open excavation shall, at all times, be confined to the limits acceptable to the Owner.
- C. Unauthorized Excavation:
  - 1. Backfill and compact to the specified grade, any excavation beyond the limits stated above for trench excavation and as shown on the Drawings (unless specifically ordered otherwise by the Engineer) with material approved by the Engineer. Backfill material may be crushed gravel or crushed stone.
  - 2. Backfill and compact unauthorized excavation at no additional cost to the Owner.
- D. Shoring and Bracing:
  - 1. Structures: Provide, install, and maintain sheeting and bracing as necessary to support the sides of the excavation and to prevent any movement of earth which could diminish the width of the excavation or otherwise injure the Work, adjacent structures and property in accordance with all State and OSHA safety standards.

2. Trenches: As trench excavation progresses, install such shoring and bracing necessary to prevent caving and sliding and to meet the requirements of the Local, State and OSHA safety standards.

E. Dewatering:

1. All necessary actions shall be taken to minimize the effect of precipitation and runoff on the work. Upgradient runoff shall be diverted from active or completed work areas, and all work shall be graded and crowned to promote controlled runoff.
2. The Contractor shall prevent surface water and subsurface or groundwater from flowing into excavations or onto any work and from flooding the project site and surrounding area.
3. Water shall not accumulate in excavations. Contractor shall remove water to prevent softening of subgrades and soil changes detrimental to stability of the subgrade. The Contractor shall dewater excavated areas as required to perform the work, and in such a manner as to preserve the undisturbed state of subgrade material.
4. The Contractor shall provide and maintain pumps, sumps, suction and discharge lines, and other dewatering system components necessary to convey water away from excavations. Discharge of dewater lines shall be directed through a dewatering filter bag, Ultratech International or equal, to remove sediment prior to discharge into existing drainage basin or stabilized drainage swale.
5. The Contractor shall prevent migration of sediment in accordance with the erosion control requirements of this Contract.

F. Fencing:

1. Structures: Erect barriers around structure excavation and other dangerous locations created by the Work to prevent entry of unauthorized personnel and at no additional cost to the Owner.
2. Trenches: If the end of the trench is allowed to be left open during nonworking hours by the Owner. The Contractor shall place barriers to prevent entry of unauthorized personnel at no additional cost to the Owner.
3. Place fences and/or suitable barriers around equipment and material to prevent damage, theft, and injury to individuals.

END OF SECTION

*SECTION 02229*  
**BACKFILL AND COMPACTION**

---

**PART 1 -- GENERAL**

**1.1 DESCRIPTION**

**A. Work Included:**

1. Work includes backfilling trenches and/or excavation around structures with suitable material removed in the course of excavating and other suitable materials.
2. Testing soils.

**1.2 REFERENCE STANDARDS**

- A. Sieve Analysis of Fine and Coarse Aggregates: ASTM C136-06
- B. Standard Practice for Sampling Aggregates: ASTM D75-04
- C. Moisture Density Relations of Soils (Modified Proctor): ASTM D1557-07
- D. Density of Soil and Soil-Aggregate In-Place by Nuclear Methods: ASTM D2922-05
- E. State of New Hampshire Department of Transportation (NHDOT) Standard Specifications for Road and Bridge Construction (latest edition)

**1.3 QUALITY ASSURANCE**

- A. The Contractor shall obtain and pay for all services of a geotechnical testing firm to perform the necessary soil and compaction tests. The independent soils laboratory shall be approved by the Engineer prior to testing.
- B. The Contractor shall make necessary arrangements to allow compaction testing to be performed at a time, place and elevation determined by the Engineer.
- C. Pre-Placement Testing.
  1. The Contractor shall take one sample of each material proposed to be used on the project. The samples shall be taken in the presence of the Engineer and in accordance with ASTM D75-03.
  2. Subgrade Material: Proctor density tests shall be performed on the existing subgrade in accordance with the following schedule and in accordance with ASTM D1557-07:
    - a. At the bottom of excavations where structures or slabs will be placed.
    - b. One after every 2,000 cubic yards has been relocated on the site.
    - c. Whenever the material has changed in the opinion of the Engineer.

3. Select and Borrow Materials: Sieve and modified proctor density tests shall be performed on all select and borrow material in accordance with the following schedule and in accordance with ASTM C136-06 and ASTM D1557-07:
  - a. Before any materials are brought to the site.
  - b. One after every 2,000 cubic yards has been brought to the site.
  - c. Whenever the source changes.
4. All test results shall be submitted to the Engineer for approval prior to placement.

D. Post-Placement Testing:

1. The trench and/or excavation shall be prepared using the normal backfill technique employed by the Contractor. No special or additional preparation will be allowed.
2. Determine in-place density in accordance with ASTM D2922-05 or by other methods as approved by the Engineer.
3. Compaction tests shall be made in accordance with the following table:

	<b>Material</b>	<b>Testing Frequency</b>	<b>Percent Compaction</b>
<b>Under Slabs or Structures:</b>			
	Native material or borrow material	One for every 500 s.f. of surface area of the slab for every 2 lifts of material placed.	95% 12" lifts
	Structural fill or crushed gravel	One for every 500 s.f. of surface area of the slab for every lift of material placed	95% 6" lifts
<b>Around Structures:</b>			
	Borrow material or other material noted on the drawings	One for every 500 l.f. of wall for every 2 lifts of material placed.	95% 12" lifts
<b>In Trenches:</b>			
	Native material or borrow material	From the blanket material to the underside of the gravel or loam. See Note #1 Below	95% 12" lifts
	Gravels or loam	See requirements for Under paved Areas and Grassed Areas for requirements below	See below
<b>Under Paved Areas:</b>			
	Native material or borrow material	One for every 10,000 s.f. of surface area for every 2 lifts of material placed.	95% 12" lifts
	Gravel	Three for every 10,000 s.f. of surface area for every lift of material placed.	95% 6" lifts
	Crushed Gravel	Three for every 10,000 s.f. of surface area for every lift of material placed.	95% 6" lifts
<b>Under Grassed or Landscaped Areas</b>			
	Native material or borrow material	One for every 20,000 s.f. of surface area for every 2 lifts of material placed.	90% 12" lifts

4. Should compaction tests fail to meet the specified densities, the Contractor shall modify backfill methods as necessary to obtain passing results. The modified method shall be used from that point on.

1.4 SUBMITTALS

- A. The Contractor shall submit at the preconstruction meeting his proposed compaction technique which shall include compaction around field structures (i.e., manholes, catch basins, etc.) and valve boxes.
- B. The Contractor shall submit sieve and proctor curves to the Engineer for approval 7 days before any material is brought to the site.
- C. The Contractor shall submit compaction test result sheets to the Engineer no later than 7 days after the tests were performed.

PART 2 -- PRODUCTS

2.1 MATERIALS

- A. Excavated Material Suitable for Reuse:
  1. Material shall be friable natural material comprised of gravels, sand, silts, or clayey gravel and sands.
  2. Material shall be free from peat, muck, other organic matter, frozen material, ice, and/or snow.
  3. Material shall be free from stones, ledge/rock fragments, and asphalt over 8” in the largest dimension.
  4. The material shall not have a moisture content over 2% of its optimum moisture content.
- B. Select and Borrow Materials:
  1. Crushed Stone (Bedding Material):
    - a. Crushed stone shall be well graded in size from 1/4 inch to 3/4 inch and shall conform to ASTM C33 stone size No. 67.
    - b. Clean, hard, and durable particles or fragments.
    - c. Sieve Analysis:

<u>Sieve Designation</u>	<u>% Passing by Weight Square Opening</u>
1"	100
3/4"	90 - 100
3/8"	20 - 55
No. 4	0 - 10
No. 8	0 - 5
No. 200	1% Max.

2. Sand (Sand Blanket or Bedding):
  - a. Clean, hard and durable particles or fragments.
  - b. Sieve Analysis:

<u>Sieve Designation</u>	<u>% Passing by Weight Square Opening</u>
3/8"	100
No. 4	95 - 100
No. 16	50 - 85
No. 50	10 - 30
No. 100	2 - 10

3. Bank Run Gravel or Granular Gravel Borrow:
  - a. Used for placement in authorized excavations below the bottom of the bedding layer to replace deficient excavated material, for road construction, pipeline construction, and other designated uses.
  - b. Material shall be hard and durable, free from frost, organic material, loam, debris and other unsuitable material. Shall not have excess amounts of clay or silt and shall be so sized that the material can be laid out and graded in smooth uniform 8" lifts.
  - c. Sieve Analysis:

<u>Sieve Designation</u>	<u>% Passing by Weight Square Opening</u>
6"	100
No. 4	25 - 70
No. 200	0 - 12 (of the sand portion)

4. Common Borrow (i.e. Sand):
  - a. Consist of earth suitable for embankment construction; free from frozen material, perishable rubbish, peat and other unsuitable material.
  - b. The moisture content shall be sufficient to provide the required compaction and stable embankment. In no case shall the moisture content exceed 4 percent above optimum.
  - c. The optimum moisture content shall be determined in accordance with AASHTO T 180, Method C or D.
  - d. 100% shall pass the 3" sieve and 70-100% shall pass the No. 4 sieve.
5. Sand (Sand Filler)
  - a. Clean, hard and durable particles or fragments.
  - b. Sieve Analysis:

<u>Sieve Designation</u>	<u>% Passing by Weight Square Opening</u>
6"	100
No. 4	75 - 100
No. 200	0 - 6

## PART 3 -- EXECUTION

### 3.1 PERFORMANCE

#### A. General:

1. Provide and place all necessary backfill material.
2. Do not allow large masses of backfill to be dropped into the excavation, as from a grab bucket, in such a manner that may endanger pipes and structures.
3. Place material in a manner that will prevent stones and lumps from becoming nested.
4. Completely fill all voids between stones with fine material.
5. Do not place backfill on or against new concrete until it has attained sufficient strength to support loads without distortion, cracking, and other damage.
6. Deposit backfill material evenly on all sides of structures to avoid unequal soil pressures.
7. Place backfill material evenly in the trench in an effort to maximize compaction.
8. Do not backfill with, or on, frozen materials.
9. Remove, or otherwise treat as necessary, previously placed material that has frozen prior to placing backfill.
10. Do not mechanically or hand compact material that is, in the opinion of the Engineer, too wet. Fill material that is too wet to be properly placed back in the trench in its current state shall be dried (disced, harrowed, etc.) to within 2% of optimum moisture content. This material shall not be classified as unsuitable material and ineligible for payment as such.
11. Material made unsuitable by the Contractor's construction methods shall be replaced with Bank Run Gravel or Granular Gravel Borrow at no additional cost to the Owner.
12. Fill that is too dry shall be uniformly watered. The water shall be placed over a loose lift to allow for the water to migrate through the entire lift before compaction.
13. Do not continue backfilling until the previously placed and/or new materials have dried sufficiently to permit proper compaction.
14. When original excavated material is, in the opinion of the Engineer, unsuitable, use only approved Bank Run Gravel or Granular Gravel Borrow for backfilling.
15. Backfill excavation/trench as early as possible to allow for the maximum time for natural settlement.
16. Slope grade away from structures at a minimum slope of 1.5%.
17. The Contractor shall remove excess fill material from the site.

#### B. Backfilling Around Trench Obstacles

1. Material must be properly compacted around trench obstacles (i.e. manholes, catch basin, valve boxes, etc.). Uncompacted fill will not be allowed to be placed around these obstacles.
2. The Contractor shall provide adequate excavation supports to allow for a safe work environment in which to properly compact the excavation/trench.



3. The Contractor shall use methods that compensate for the space limitations in the immediate area around these obstacles.

C. Backfilling in Paved Areas:

1. Backfill trenches in streets and other paved areas by maintaining a moisture content within 2% of optimum.
2. In an effort to allow the road to heave uniformly, backfill material that was removed from the top portion of the trench shall be replaced back into the top of the trench. Similarly, the material removed from the middle of the trench shall be replaced back into the middle of the trench. Existing material removed from the bottom of the trench (i.e. where the pipe box is located) shall be stockpiled for later use.
3. Backfill in such a manner as to permit the rolling and compaction of the filled trench with the adjoining material to provide the required bearing value for paving immediately after backfilling is completed.
4. Where required, place excavated material, that is acceptable to the Engineer for surfacing or pavement subbase, at the top of the backfill to the depths as needed to adequately support pavement.

D. Backfilling Trenches in Nonpaved Areas:

1. Grade the ground to a reasonable uniformity.
2. Leave the mounding over the trenches in a uniform and neat condition, satisfactory to the Engineer.

E. Bedding & Backfilling of Pipelines:

1. Install pipe bedding and cushion and primary backfill in accordance with the requirements noted herein, and in the specific pipe Specification Section, and on the Drawings.
2. Deposit and thoroughly compact the remainder of the backfill as noted herein.

F. Placing and Compacting Backfill:

1. Water Jetting: Shall not be allowed without the approval of the Engineer.
2. Puddling: Shall not be allowed without the approval of the Engineer.
3. Tamping:
  - a. Deposit and spread the backfill material in uniform parallel layers not exceeding the lift thicknesses noted herein.
  - b. Tamp each layer as required to obtain a thoroughly compacted mass.
  - c. If necessary, furnish and use an adequate number of power driven tampers, each weighing at least 150 lbs.
4. Rolling:
  - a. Compact material by rolling only when the width and depth of the excavation are sufficient to accommodate the rollers, dozers, mechanical tampers, or other similar powered equipment, as may prove to be acceptable, and when it can be performed without causing damage to pipes and structures installed in the excavation.
  - b. Deposit and spread the backfill material in uniform parallel layers not exceeding the lift thicknesses noted herein.
  - c. Roll each layer as required to obtain a thoroughly compacted mass.

5. Other placing and compacting methods may be employed only when approved by the Engineer.

G. Improper Backfill

1. When, in the opinion of the Engineer, excavation and trenches have been improperly backfilled, and when settlement occurs, reopen the excavation to the depth required, as directed by the Engineer.
2. Refill and compact the excavation or trench with suitable material and restore the surface to the required grade and condition.
3. Excavation, backfilling, compacting work and testing performed to correct improper backfilling shall be performed at no additional cost to the Owner.

END OF SECTION

*SECTION 02370*  
**EROSION CONTROL**

---

PART 1 – GENERAL

1.1 DESCRIPTION

A. Work Included:

1. Permanent Control - This work shall consist of furnishing and placing hay mulch, bark mulch, or matting on surfaces prepared and seeded under other items, at locations shown on the plans or as required by the Engineer.
2. Temporary Control - Comply with all Federal, State and local regulations pertaining to erosion and sediment control and stormwater management.
3. Provide all labor, equipment, materials and maintain temporary erosion control devices as shown on the plans or as required by the Engineer.
4. Provide such erosion control measures as may be necessary to correct conditions that develop prior to the completion of permanent erosion control devices and/or as required to control erosion that occurs during normal construction operations.
5. Provide such sediment control measures as may be necessary to address conditions created by construction dewatering methods and/or stormwater runoff.
6. After award of the Contract and prior to commencement of construction activities, meet with the Engineer to discuss the Erosion Control Plan and develop a mutual understanding relative to maintaining effective erosion and water controls throughout construction.
7. Conduct all construction in a manner and sequence that causes the least practical disturbance of the physical environment.
8. Stabilize disturbed earth surfaces in the shortest practical time and employ such temporary erosion control devices as may be necessary until such time as adequate soil stabilization has been achieved.

1.2 REFERENCE STANDARDS

- A. AASHTO Highway Drainage Guidelines, Volume III, Guidelines for Erosion and Sediment Control in Highway Construction, 4<sup>th</sup> Edition, American Association of State and Highway Transportation Officials, Inc., 444 North Capital St. N.W., Suite 249, Washington, D.C. 20001.

- B. The New Hampshire Stormwater Manual, Volume III, Erosion and Sediment Controls During Construction, December 2008, New Hampshire Department of Environmental Services, Public Information Office, 29 Hazen Drive, Concord, New Hampshire, 03301.
- C. Storm Water Phase II Compliance Assistance Guide, Section 5 Small Construction Activity, United State Environmental Protection Agency, Publication No. 833-R-00-003.

## PART 2- PRODUCTS

### 2.1 MULCH

- A. Hay mulch shall consist of cured hay, free from weeds and rough or woody materials.
- B. Bark mulch shall be bark chippings graded to be approximately 3/8 inch to 2 inches in width. The chippings shall not have been stored so long and under such conditions that the material has decomposed sufficiently so that it has lost its fibrous texture. Bark mulch must be approved as to grading and condition prior to its use.

### 2.2 SEED FOR EROSION CONTROL

Seed for erosion control shall be one of the following:

- A. Seed for temporary control shall be annual or perennial ryegrass.
- B. Seed for a more permanent control shall be slope seed mix as specified in Section 02935.

### 2.3 HAY BALES

- A. Hay bales for erosion control shall consist of rectangular shaped bales of hay or straw weighing at least 40 pounds per bale. They shall be free from weed seeds and rough or woody materials.

### 2.4 SILT FENCE

Silt fence for erosion control shall be Propex Silt-Stop sediment control fabric or approved equal.

- A. Either wood or steel posts may be used. Wood posts shall be sound quality hardwood with a minimum cross sectional area of three square inches. Steel post shall be standard T or U section weighing not less than 1 pound per linear foot with projections for fastening wire to the fence. Maximum post spacing shall be 10 feet.
- B. Wire support fence, if required, shall be a minimum of 14.5 gauge woven wire with a maximum 6 inch mesh.

## 2.5 CATCH BASIN INSERTS

Catch basin inserts shall be Dandy Sack or equal.

## PART 3 – EXECUTION

### 3.1 MULCH

- A. Mulching shall be done immediately after each area has been properly prepared. When seed for erosion control is sown prior to placing the mulch, the mulch shall be placed on the seeded areas within 48 hours after seeding. Hay that has been thoroughly fluffed shall be applied at approximately, but not to exceed, three tons per acre unless otherwise specified. Blowing chopped hay mulch will be permitted provided the Contractor controls the mulching operation so as not to infringe on property owners or the traveling public. Blown hay mulch shall be applied in such a manner resulting in a minimum amount of matting that would retard the growth of plants. Hay mulch should cover the ground enough to shade it, but the mulch should not be so thick that a person standing cannot see ground through the mulch. Matted mulch or bunches shall be removed or otherwise remedied.
- B. In order to prevent mulch from being blown away, approved tackifier shall be employed.
- C. All baling wire or rope, such as that used in the shipment of mulch, shall be disposed of off site by the Contractor.
- D. Bark mulch shall be placed in designated areas to the depth specified on the plans.

### 3.2 SEED FOR EROSION CONTROL

- A. Seeding, when required, shall be performed in accordance with Section 02935.
  - 1. Areas of the roadside which are to be left temporarily and which will be regraded or otherwise disturbed later during construction may be ordered to be seeded with ryegrass to obtain temporary control. The seed shall be sown at the rate of approximately 1 pound per 1,000 square feet.

### 3.3 HAY BALES FOR EROSION CONTROL

- A. Hay bales shall be placed as ordered to provide for temporary control of erosion or pollution or both. They shall be staked with the required stakes. Upon acceptance of the contract, the bales shall be left in place unless required to be removed by the Engineer. The Contractor shall be responsible for any erosion damage caused by water bypassing any hay bale.

### 3.4 SILT FENCE

- A. The Contractor shall construct and dismantle the silt fence as shown on the plans and as recommended by the manufacturer.
  - 1. When two sections of filter fabric adjoin each other, they shall be overlapped by 6 inches, folded, and stapled at a post.
  - 2. Woven wire fence, when required, shall be fastened securely to the fence posts with staples or wire ties.
  - 3. Filter fabric shall be fastened to the woven wire fence, when wire fence is required, with ties spaced every 2 feet longitudinally at the top, mid-section, and bottom.
  
- B. Care shall be taken to maintain the silt fence in a functional condition at all times during the construction period.
  - 1. Silt fences shall be inspected immediately after each rainfall event and at least daily during prolonged rainfall. All deficiencies shall be immediately corrected by the Contractor.
  - 2. Remove retained material when "bulges" develop in the silt fence.
  - 3. Sediment deposits shall be inspected after every storm event and removed when deposits reach approximately one-half the height of the silt fence.
  - 4. Fabric which has decomposed, has become ineffective or does not retain silt or suspended solids and is still needed, shall be replaced.
  
- C. The Contractor shall remove the silt fence after all work has been completed and it is no longer needed or as required by the Engineer.
  - 1. Sediment deposits that are removed or left in place after the fabric has been removed shall be graded to conform with the existing topography and shall be vegetated.
  
  - 2. The silt fence will become the property of the Contractor upon completion of the project and removed and disposed of by the Contractor.

### 3.5 CATCH BASIN INSERT

- A. The Contractor shall install and maintain the inserts where shown on the Drawings or where necessary to prevent discharge of sediment to existing drainage systems.
  
- B. Insert shall be placed in the catch basin opening, setting the grate on-top to hold the fabric and basket securely in place and reseal the pre-filter top of the unit to contain sediment.
  
- C. Remove all accumulated sediment and debris from the surface and vicinity of unit after each storm event. After each storm event, and at regular intervals, inspect the unit for accumulated sediment and empty the unit when the visual indicator is covered or as indicated by the manufacturer.

- D. Empty the contents of the unit and dispose of sediment at an appropriate facility off-site.
- E. At the completion of the work that has the potential to discharge sediment or when the insert is no longer performing satisfactorily, remove and replace the units as applicable and dispose of the unit in accordance with applicable laws and regulations.

END OF SECTION

SECTION 02500  
SIDEWALKS

1.01 SCOPE OF WORK

- A. The work shall consist of constructing brick sidewalks as directed in the field by the Engineer.

1.02 METHODS OF CONSTRUCTION

- A. All labor and materials shall conform to the State of New Hampshire Standard Specifications for Road and Bridge Construction, Section 608.
- B. Brick Pavers shall be Old Port Pavers manufactured by Morin Brick PO Box 1570 Auburn, ME. 04211 (207) 784-9375. New bricks shall conform to the requirements of ASTM Standard Specifications for Building Bricks Designation C902 SX for Grade SW. The bricks shall be No. 1, wire cut type for paving, with a compressive strength of not less than 6,000 pounds per square inch. The bricks shall not be cored or have frogs and shall be of a standard size (2.25" x 3.625" x 7.625"). The Engineer will have 5 working days to approve the brick submittals before they are installed. It is the responsibility of the Contractor to provide suitable brick samples for approval.
- C. Excavation for sidewalks shall be at a depth of 13 inches below finish grade. In areas not butting curbing or buildings, the excavation shall be 6 inches wider than the finished sidewalk width. At all drive crossings, the depth of excavation shall be increased accordingly. The Contractor's price shall include neat and square cutting of existing asphalt road surface as needed. All unsuitable material shall be removed and disposed of off-site at the Contractor's own expense.
- D. The base material for sidewalks shall consist of 8" of type 304.3 crushed gravel.
- E. The Contractor shall lay the bricks so that approximately 5 bricks shall cover one square foot.
- F. The sidewalk shall pitch 1/4 inch per foot towards the street or as directed.
- G. In areas where the edge of the brick sidewalk is not adjacent to granite curbing, the Contractor shall install edging to hold the bricks in place. Such edging shall be installed per the manufacturer's recommendations.
- H. In areas with a closed drainage system, the contractor shall provide "silt sacks" to prevent brick dust from entering the collection system. Also, the area will be swept daily to keep dust levels as low as possible.
- I. All half bricks will be snapped if possible and all efforts will be made to keep brick dust to a minimum. All cuts not made by snapping will be wet cut.
- J. Prior to placing the brick, the sidewalks will be paved parallel to grade with 3/8" bituminous asphalt type F hot mix paving 1 1/2" compacted thickness. Paving for this will be paid for under item 403.12. 1" of 1:3 portland cement / course sand mix will then be placed on the asphalt base and the pavers will be dry laid on the mixture.



*SECTION 02551*  
**BITUMINOUS PAVEMENT**

---

PART 1 -- GENERAL

1.1 DESCRIPTION

A. Work Included:

1. This work shall consist of constructing one or more courses of bituminous pavement on a prepared base as shown on the Plans. The methods may be classified as hand or machine.
2. Hand method shall include only the paving of existing sidewalks, drives, curb patch between granite curb and pavement, and paving of 50 tons or less added after the completion of paving operations.
3. Machine method shall include all paving not classified as hand method.

PART 2-- PRODUCTS

2.1 AGGREGATE MATERIALS AND BITUMINOUS MATERIALS SHALL COMPLY WITH NHDOT AND AASHTO STANDARDS.

- A. Gradation. Coarse and fine aggregate shall each be of such gradation that, when combined with other required aggregate fractions in proper proportion, the resultant mixture will meet the gradation required under composition of mixture for the specific type under contract (see Table 2). Not more than 10 percent of the fine aggregate blend shall pass the No. 200 sieve. Grading of mineral filler shall conform to the required grading of AASHTO M 17 except that 100 percent shall pass the No. 20 sieve, waiving the requirement for the No. 3 sieve.

2.2 COMPOSITION OF MIXTURES.

The bituminous plant mix shall be composed of a mixture of aggregate, filler if required, and bituminous material. The several aggregate fractions shall be sized, uniformly graded, and combined in such proportions that the resulting mixture meets the grading requirements of the job mix formula.

- A. Job mix. The general composition limits given in Table 2 indicate the master range of mixtures permissible under this specification. No work shall be started on a paving project until the Engineer reviews and approves the job mix formula proposed by the Contractor. The job mix formula shall lie within the master range indicated for the particular type of bituminous concrete specified. The job mix formula for each mixture shall establish a single percentage of aggregate passing each required sieve size, a single percentage of bituminous material to be added to the aggregate, and a single temperature at which the mixture is to be delivered at the point of discharge. This temperature is subject to change as required depending upon the conditions of the day. Gradings that range from the

maximum of one sieve to the minimum of the next will not be permitted. The job mix formula for each mixture shall be in effect for the project.

B. After the job mix formula is established, all mixtures furnished for the project shall conform within the following ranges of tolerances:

Passing No. 4 and larger sieves	±7 percent
Passing No. 10 to No. 80 sieves (inclusive)	±4 percent
Passing No. 200 sieve	±2 percent
Bitumen	±0.4 percent
Temperature of mixture	±11E C (20E F)

**Table 2 - Composition of Mixtures - Master Ranges (English) <sup>(1)</sup>**

	Base Courses <sup>(2)</sup>			Wearing Courses		
	Type B: 3/4 in			Type E: 1/2 in		
<i>Percentage by Weight Passing - Combined Aggregate</i>						
	Min	Desired	Max	Min	Desired	Max
1-1/4 in						
1 in						
3/4 in	95	100	100			
1/2 in	70	81	92	95	100	100
3/8 in	60	71	80	85	90	95
No. 4	42	50	57	60	66	75
No. 10	28	32	38	38	46	50
No. 20	16	20	24	24	27	32
No. 40	9	13	17	14	19	23
No. 80	3	7	11	6	11	14
No. 200	0	3	4	2	3	6
Asphalt Cement: % of Mix <sup>(3)</sup>	4.8	5.25	6.0	6.0	6.4	7.0

- (1) Grading approaching the maximum amount permitted to pass the various sieves will result in pavement surfaces having comparatively fine texture, while gradings approaching the minimum amounts passing the various sieves will result in surfaces with comparatively coarse textures.
- (2) Alternate aggregate sizes are included to ensure that the coarse aggregate shall not be larger than one-half the thickness of the layer being placed.
- (3) The asphalt content for the above mixture is based on the use of aggregate with a specific gravity of 2.65 to 2.70. The asphalt content will be adjusted when aggregate with a higher specific gravity is used.

*SECTION 02552*  
**SAWED PAVEMENT**

---

PART 1 – GENERAL

1.1 DESCRIPTION

A. Work Included:

1. This work shall consist of sawing bituminous pavement as shown on the Plans or as required.

PART 2—PRODUCTS

Not Used

PART 3 – EXECUTION

- 3.1 Bituminous pavement to be sawed shall be accurately marked before sawing.
- 3.2 The equipment used to saw bituminous pavement shall be capable of sawing the pavement as shown on the Plans or as required and shall produce a substantially vertical and sound face without deformation of the adjacent pavement. The use of methods other than sawing (i.e., cutting wheels, pavement breakers), which deform the pavement or leave an unsound face, will not be permitted.
- 3.3 Bituminous pavement to be sawed in connection with laying pipes, roadway excavation, constructing curb, and the like shall be sawed to a sufficient depth to permit breaking the pavement at the cut.
  - A. Where the pavement is found to consist of an overlay of bituminous pavement above a concrete slab, the cut shall be increased enough to score the underlying concrete so that the concrete may be broken in a uniform manner.

END OF SECTION

*SECTION 02622*  
**PVC PIPE AND FITTINGS**

---

**PART 1 -- GENERAL**

**1.1 DESCRIPTION**

- A. Work Included: Furnish, install and test PVC pipe of the size(s), type(s) and in the location(s) shown on the Drawings and or specified herein.

**1.2 REFERENCE STANDARDS**

- A. Rubber Rings for Pressure Sewer: ASTM D-1869
- B. Pressure Sewer Pipe: ASTM D-1784
- C. Polyvinyl Chloride (PVC) Plastic Pipe: ASTM D2241
- D. Polyvinyl Chloride (PVC) Pressure Pipe and Fabricated Fittings 4" through 12" for Water Distribution: AWWA C900
- E. Underground Installation of Flexible Thermoplastic Sewer Pipe: ASTM D2321
- F. Polyvinyl Chloride (PVC) Sewer Pipe and Fittings 4"-15": ASTM D3034
- G. Joints for Drain and Sewer Plastic Pipes Using Flexible Elastomeric Seals: ASTM D3212
- H. Standard Specification for Joints for Plastic Pressure Pipe Using Flexible Elastomeric Seals: ASTM D3139
- I. Elastomeric Seals (Gaskets) for Joining Plastic Pipe: ASTM F477
- J. Polyvinyl Chloride (PVC) Sewer Pipe and Fittings 18"-27": ASTM F679
- K. Polyvinyl Chloride (PVC) Sewer Pipe and Fittings 27"-48": ASTM 794

**1.3 QUALITY ASSURANCE**

- A. Manufacturer shall have a minimum of five (5) years experience in the manufacture of PVC sewer pipe.

**1.4 SUBMITTALS**

- A. Submit manufacturer's literature, test reports, and certificates in accordance with the General Conditions and Section 01340 - Submittals.

## 1.5 DELIVERY, STORAGE & HANDLING

- A. Deliver as job progress requires and store on a smooth bed to prevent point loading.
- B. Stack pipe in accordance with manufacturer's instructions; however, no higher than four feet.
- C. Exercise extra care when handling.
- D. All pipe and fittings shall be stored with an adequate cover to protect from sunlight.

## 1.6 INSPECTION

- A. Provide all labor necessary to assist the Engineer to inspect pipe, fittings, gaskets, and other materials.
- B. Carefully inspect all materials at the time of delivery and just prior to installation.
- C. Carefully inspect all pipe and fittings for:
  - 1. Defects and damage.
  - 2. Deviations beyond allowable tolerances for joint dimensions.
  - 3. Removal of debris and foreign matter.
- D. Examine areas and structures to receive piping for:
  - 1. Defects, such as weak structural components, that adversely affect the execution and quality of work.
  - 2. Deviations beyond allowable tolerances for pipe clearances.
- E. All materials and methods not meeting the requirements of the Contract Documents will be rejected.
- F. Immediately remove all rejected materials from the project site.
- G. Start work only when conditions are corrected to the satisfaction of the Engineer.

## PART 2 -- PRODUCTS

### 2.1 MATERIALS

- A. Pipe & Fittings:
  - 1. Type - Polyvinylchloride (PVC) plastic pipe with integral bell and spigot joints. Polymer compounding and classification shall be in accordance with ASTM D-1784 (Class 1254-B).
  - 2. Gravity Sewers:
    - a. 4" - 15" nominal diameter sizes shall conform to ASTM D-3034 and SDR=35.

- b. 18" - 36" nominal diameter sizes shall conform to ASTM F-679 (wall thickness T-1).
- c. 27" - 48" nominal diameters shall conform to ASTM 794.
- 3. Pressure Sewers shall conform to ASTM D-2241 and D-1784, Class 12454-B, with maximum SDR=26. A safety factor of 2.5 shall be used for pressure rating determination.
- 4. Gravity Sewers where less than 10-foot horizontal separation is provided to water lines or where otherwise shown on the Drawings shall conform to AWWA C900.
- 5. Furnish straight pipe in standard laying lengths, 12.5 and 20 feet for 18" diameter and less, 12 and 19.5 feet for 21", 24" and 27" diameter.
- 6. Furnish fittings of approved equal to the pipe and having bell and spigot configuration identical to that of the pipe.
- 7. Pipe and fittings shall be as manufactured by J-M Manufacturing, Ipex Inc., Certain Teed or approved equal.
- 8. Each pipe and fitting shall have the manufacturer's name (or trademark), pipe type and size, and material designation clearly marked on it.

B. Joints:

- 1. Type - Flexible elastomeric seal conforming to ASTM D-3212 with push-on bell and spigot.
- 2. Gaskets shall conform to ASTM F-477.
- 3. Rubber rings for pressure sewer shall conform to ASTM D-1869 and ASTM F477.
- 4. Gasketed joints for C900 pipe shall conform to ASTM D-3139

C. Couplings:

- 1. Flexible and transition couplings for nonpressure sewer pipe shall be resilient plastic with recessed stainless steel bands at each end. Couplings shall be as manufactured by Fernco, Inc. or approved equal.

## 2.2 ALTERNATES

- A. Products of equal or better quality, function and performance may be proposed.

## PART 3 -- EXECUTION

### 3.1 INSTALLATION

- A. Install in accordance with the manufacturer's written instructions and as shown on the Drawings.
- B. In general, gravity pipe laying shall proceed upgrade with spigot ends pointing in the direction of flow.
- C. Exercise extra care during winter construction as the pipe's impact strength is lower.

- D. Prior to backfilling, exercise extra care to maintain water level in open excavation below the pipe invert to avoid flotation of pipe already set to line and grade.
- E. Install all sewer mains with the use of a laser to maintain line and grade. Use of string lines, hand levels, or similar type tools shall not be permitted.
- F. All services shall extend from the wye to the property line where a new cleanout shall be installed. See the drawings for the cleanout detail.

### 3.2 CLEANING AND TESTING

- A. Clean and test PVC pipes: Refer to Section 02651 - Final Sewer Testing for testing requirements.

END OF SECTION

*SECTION 02625*  
**CORRUGATED POLYETHYLENE (CPE) PIPE AND FITTINGS**

---

**PART 1 -- GENERAL**

**1.1 DESCRIPTION**

- A. Work Included: Furnish, install, anchor, support and test pipe and pipe fittings of the types and sizes in the locations shown on the Drawings and/or as directed by the Engineer.
- B. Work Specified Elsewhere. The following is a list of Sections that note work related to this Section. The list is provided for the Contractor's convenience and is not intended to relieve the Contractor of requirements noted in Sections that are not listed below.
  - 1. Section 02220 – Excavation
  - 2. Section 02229 – Backfill and Compaction
  - 3. Site work requirements as specified in Division 2.

**1.2 REFERENCE STANDARDS**

- A. Tubing three (3) inches to ten (10) inches: AASHTO M252
- B. Pipe twelve (12) inches to forty eight (48) inches: AASHTO M294
- C. Polyethylene Moulding & Extrusion materials: ASTM: D1248
- D. Polyethylene Plastic Pipes and Fittings: ASTM D3350

**1.3 QUALITY ASSURANCE**

- A. Pipe, pipe fittings and where applicable, geotextile wrap or sock shall be provided by a single manufacturer, and a certificate of compliance will be submitted to the Engineer for approval.

**1.4 SUBMITTALS**

- A. Submit manufacturer's literature, test reports, and certificates in accordance with the General Conditions and Section 01340 - Submittals.

**1.5 TRANSPORTING, HANDLING AND STORING PIPE**

- A. Transporting
  - 1. Care shall be taken during the transportation of the pipe in trucks and trailers so that it is not damaged from cuts and kinks.



B. Handling

1. The handling and lifting of pipe lengths and fittings shall be such as to avoid damage and shall be done by means of ropes, fabric or rubber protected slings and straps.
2. The pipe shall not be lifted by means of metal slings, chains, cables or hooks inserted into the pipe ends. Slings shall be positioned to prevent excessive flexing of the pipe lengths to avoid kinking or damage to the pipe ends.
3. The pipe lengths shall not be dragged from the transportation media or allowed to fall onto unprepared or rocky ground.
4. The handling of the joined pipe line shall be done in such a manner that the pipe is not damaged by dragging it over sharp and cutting objects.

C. Storing

1. The stacking of the polyethylene pipe shall be limited to such a height as to not cause excessive deformation of the bottom layers of pipes under anticipated temperature conditions.
2. The surface where the pipe shall be stored shall be level and free of foreign objects which could damage the pipe.
3. Where necessary due to ground conditions, the pipe shall be stored on wooden sleepers of sufficient bearing and spacing.

1.6 INSPECTION

- A. Provide all labor necessary to assist the Engineer to inspect pipe, fittings, gaskets, and other materials.
- B. Carefully inspect all materials at the time of delivery and just prior to installation.
- C. Carefully inspect all pipe and fittings for:
  1. Defects and damage.
  2. Deviations beyond allowable tolerances for joint dimensions.
  3. Removal of debris and foreign matter.
- D. Examine areas and structures to receive piping for:
  1. Defects, such as weak structural components, that adversely affect the execution and quality of work.
  2. Deviations beyond allowable tolerances for pipe clearances.
- E. All materials and methods not meeting the requirements of the Contract Documents will be rejected.
- F. Immediately remove all rejected materials from the project site.
- G. Start work only when conditions are corrected to the satisfaction of the Engineer.

## PART 2 -- PRODUCTS

### 2.1 MATERIALS

#### A. General

1. The prescribed sizes of pipes are nominal inside diameters. Pipes shall be of the size and length shown on the plans.
2. All drainage pipe shall be smooth interior unless otherwise noted.
3. Resin used in the manufacturing of pipe and fittings shall meet the requirements of cell class 324420C as defined in ASTM 3350.
4. Carbon black content shall not exceed 5%.

#### B. Smooth Interior Corrugated Polyethylene Pipe

1. The product supplied under this specification shall be high density polyethylene corrugated exterior/smooth interior pipe. Four (4) to ten (10) inch diameter pipe shall conform to AASHTO M252. Twelve - to 36 - inch diameter pipe shall conform to AASHTO M294 Type S. Forty-two and 48 - inch diameter pipe shall have minimum pipe stiffness of 20 and 17 psi, respectively, at 5% deflection; and shall meet all other requirements of AASHTO M294.
2. Material shall meet ASTM D1248 Type III, Category 4, Grade P33, Class C; or ASTM D3350 Cell Classification 324420C.

#### C. Coupling Bands and Fittings

1. Coupling bands shall cover at least one full corrugation on each section of pipe. When gasketed coupling bands are required, the gasket shall be made of closed-cell synthetic expanded rubber meeting the requirements of ASTM D1056, Type 2. Gaskets shall be installed on the coupling band by the pipe manufacturer. All coupling bands shall meet or exceed the soil-tightness requirement of the AASHTO Standard Specification for Highway Bridges, section 23, paragraph 23.3.1.5.4(e).
2. Furnish fittings of approved equal to the pipe and having connection configurations identical to that of the pipe.
3. Pipe fittings shall conform to AASHTO M294.

#### D. Acceptable Manufacturers:

1. Hancor, Inc., Findlay Ohio
2. Advanced Drainage Systems, Columbus Ohio

### 2.2 ALTERNATES

- A. Products of equal or better quality, function and performance may be proposed by following the procedures in Section 01630 – Alternates and Product Options.

## PART 3 -- EXECUTION

### 3.1 INSTALLATION

- A. Installation shall be in accordance with manufacturer's recommendations and as shown on the drawings.
- B. Prior to backfilling, exercise extra care to maintain water level in open excavation below the pipe invert to avoid flotation of pipe already set to line and grade.
- C. Flared end sections shall be fully supported.
- D. Stones larger than 3 inches in diameter shall not contact the pipe, fittings or appurtenances.

### 3.2 INSPECTION AND CLEANING

- A. Inspect all drain pipes in the presence of the Owner and the Engineer. All pipes not demonstrating uniform slope and alignment shall be replaced at no additional cost to the Owner.
- B. At the end of the project and prior to acceptance by the Owner, all drainage pipe shall be thoroughly cleaned and, where accessible, visually inspected.

END OF SECTION

*SECTION 02626*  
**COPPER SERVICE PIPE**

---

**PART 1 -- GENERAL**

**1.1 DESCRIPTION**

- A. Work Included: Furnish and install copper service pipe of the type and size and in the locations shown on the Drawings and as specified herein.
  
- B. Work Specified Elsewhere. The following is a list of Sections that note work related to this Section. The list is provided for the Contractor's convenience and is not intended to relieve the Contractor of requirements noted in Sections that are not listed below.
  - 1. Section 02220 –Excavation
  - 2. Section 02229 –Backfill and Compaction
  - 3. Section 02630 – Couplings, Connectors, Caps and Plugs

**1.2 REFERENCE STANDARDS**

- A. Seamless copper water tube: ASTM B88.

**1.3 SUBMITTALS**

- A. Submit manufacturer's literature, test reports, and certificates.

**1.4 DELIVERY, STORAGE & HANDLING**

- A. Store pipe to prevent damage and in accordance with manufacturer's instructions.

**PART 2 -- PRODUCTS**

**2.1 MATERIALS**

- A. American Made, Type K, soft annealed, 3/4" (minimum) through 1".
- B. American Made, Type K, hard tempered, 1-1/4 inches and larger.
- C. All pipe shall have the manufacturer's trademark and type stamped on the pipe.

**2.2 ALTERNATES**

- A. Products of equal or better quality, function and performance may be proposed.

## PART 3 -- EXECUTION

### 3.1 INSTALLATION

- A. Install pipe from the new corporation stop to the new curb stop and connect to the existing service pipe.
- B. A “goose-neck” shall be placed in the pipe at the corporation stop as shown on the drawings.
- C. Place sand below, adjacent to, and above the pipe as shown on the drawings.

### 3.2 JOINING

- A. Compression Joints
  1. Ream or file the pipe to remove burrs.
  2. Slip compression nut over pipe and slide pipe into corporation.
  3. Tighten compression nut.
  4. Inspect for cracks, splits or other damages and replace if necessary.
  5. Adapters: Use as required to connect to existing services.

### 3.3 BENDING PIPE

- A. Bend pipe with suitable tools and provide smooth bend free of any kinks, cracks or buckles.

### 3.4 TESTING

- A. Services shall be installed after the water main has been successfully tested for leakage and bacteria.

END OF SECTION

*SECTION 02630*  
**COUPLINGS, CONNECTORS, CAPS AND PLUGS**

---

**PART 1 -- GENERAL**

**1.1 DESCRIPTION**

- A. Work Included: Furnish and install couplings and connectors of the type(s) and size(s) in the location(s) shown on the Drawings and as specified herein.
- B. Work Specified Elsewhere. The following is a list of Sections that note work related to this Section. The list is provided for the Contractor's convenience and is not intended to relieve the Contractor of requirements noted in other Sections.

**1.2 QUALITY ASSURANCE**

- A. Minimum pressure rating equal to that of the pipeline in which they are to be installed.
- B. Couplings and connectors, other than those specified herein, are subject to the Engineer's approval.
- C. Cap and plug shop drawing submissions must be accompanied by a manufacturer's written certification that the cap or plug will effectively and permanently seal the inactivated or abandoned utility.

**1.3 SUBMITTALS**

- A. Submit manufacturer's literature, test reports, and certificates.

**1.4 DELIVERY, STORAGE & HANDLING**

- A. Store to prevent damage and in accordance with manufacturer's instructions.

**PART 2 -- PRODUCTS**

**2.1 MATERIALS**

- A. All Couplings and Connectors:
  - 1. Gasket Materials: Composition suitable for exposure to the liquids to be contained within the pipes.
  - 2. Diameters to properly fit the specific types of pipes on which couplings and connectors are to be installed.

- B. Sleeve Type Couplings (When Applicable):
  - 1. Exposed Couplings (When Applicable):
    - a. Steel middle ring,
    - b. Two steel follower rings,
    - c. Two wedge-section gaskets,
    - d. Sufficient steel bolts to properly compress the gaskets,
    - e. Acceptable Manufacturers:
      - 1) Dresser Manufacturing Co. - Style 38,
      - 2) Smith-Blair Inc. - Style 411, or approved equal.
  - 2. Buried Couplings (When Applicable):
    - a. Cast or ductile iron middle rings with pipe stops removed,
    - b. Two malleable iron follower rings with ribbed construction,
    - c. Two wedge-section gaskets,
    - d. Sufficient galvanized steel bolts to properly compress the gaskets,
    - e. Acceptable Manufacturers:
      - 1) Rockwell brand 441 or approved equal
- C. Flexible Joints:
  - 1. Expansion Joints:
    - a. Materials shall be capable of withstanding the temperature, pressure and type of material in the pipeline.
    - b. Shall be the filled arch type that will prevent sediment build-up for all sludge, sewage, and other lines with similar service.
    - c. Supplied with control rods to restrict elongation and compression.
    - d. Metal retaining rings shall be split and beveled galvanized steel for placement against the flange of the expansion joint.
  - 2. Deflection Joints:
    - a. Joints designed to permit a nominal maximum deflection of 15 degrees in all directions from the axis of the adjacent pipe length, will prevent pulling apart, and will remain watertight at any angle of deflection under 15 degrees.
    - b. Material to be manufactured from a composition material suitable for exposure to the liquid, pressure and temperature to be contained within the pipe.
    - c. Supplied with control rods as required.
- D. Caps and Plugs:
  - 1. Cap and plug material shall be as indicated on the Drawings and shall be adaptable to the inactive or abandoned utility to be capped or plugged.
  - 2. Caps shall be asphalt coated inside and out and shall be mechanical joint.

## 2.2 ALTERNATES

- A. Products of equal or better quality, function and performance may be proposed.

## PART 3 -- EXECUTION

### 3.1 INSTALLATION

- A. Sleeve Type Couplings (When Applicable):
  1. Thoroughly clean pipe ends for a distance of 8 inches from the ends prior to installing couplings, and use soapy water as a gasket lubricant.
  2. Slip a follower ring and gasket (in that order) over each pipe and place the middle ring centered over the joint.
  3. Insert the other pipe length into the middle ring the proper distance.
  4. Press the gaskets and followers evenly and firmly into the middle ring flares.
  5. Insert the bolts, finger tighten and progressively tighten diametrically opposite bolts uniformly around the flange to the torque recommended by the manufacturer.
  
- B. Buried Couplings, Adapters and Connectors (When Applicable): Thoroughly coat all exterior surfaces, including nuts and bolts, after assembly and inspection by the Engineer with a heavy-bodied bituminous mastic as approved by the Engineer.
  
- C. Install thrust rods, supports and other provisions to properly support pipe weight and axial equipment loads.
  
- D. Install caps and plugs in accordance with manufacturer's recommendations to ensure a permanent seal of the inactive or abandoned utility.

END OF SECTION



*SECTION 02651*  
**FINAL SEWER TESTING**

---

PART 1 -- GENERAL

1.1 DESCRIPTION

A. Work Included:

1. All sewers, manholes, and appurtenant work, in order to be eligible for approval by the Engineer, shall be subjected to tests that will determine the degree of watertightness and horizontal and vertical alignment.
2. Final sewer testing work includes the performance of testing and inspecting each and every length of sewer pipe, pipe joints and each item of appurtenant construction.
3. Perform testing at a time approved by the Engineer, which may be during the construction operations, after completion of a substantial and convenient section of the work, or after the completion of all pipe laying operations.
4. Provide all labor, pumps, pipes, connections, gauges, measuring devices and all other necessary apparatus to conduct tests.

B. Work Specified Elsewhere. The following is a list of Sections that note work related to this Section. The list is provided for the Contractor's convenience and is not intended to relieve the Contractor of requirements noted in Sections that are not listed below.

1. Section 02622 – PVC Pipe and Fittings

1.2 REFERENCE STANDARDS

- A. Low Pressure Air Testing: ASTM C-828 & UNI-B-6

PART 2 -- PRODUCTS

(NOT PART OF THIS SECTION)

PART 3 -- EXECUTION

3.1 PERFORMANCE

A. General:

1. Thoroughly clean all sewer lines to be tested, in a manner and to the extent acceptable to the Engineer, prior to initiating test procedures.
2. Perform all tests and inspections only under the direct observation of the Engineer and the plumbing or building inspector and in accordance with the requirements of the local and State plumbing codes.

3. Prior to construction, inform the Engineer of the planned sewer testing pattern.
4. Remedial Work:
  - a. Perform all work necessary to correct deficiencies discovered as a result of testing and/or inspections.
  - b. Completely retest all portions of the original construction on which remedial work has been performed.
  - c. Perform all remedial work and retesting in a manner and at a time approved by the Engineer at no additional cost to the Owner.

B. Line Acceptance Tests (Gravity sewers):

1. Test all gravity sewer lines for leakage by conducting a low pressure air test conforming to ASTM C-828. Conduct all tests after the tees or saddles and service connections have been installed to the limit indicated on the Contract Drawings. Conduct all tests after backfilling the sewer line trenches.
2. Equipment:
  - a. Pneumatic plugs shall have a sealing length equal to or greater than the diameter of the pipe to be inspected.
  - b. Pneumatic plugs shall resist internal test pressures without requiring external bracing or blocking.
  - c. All air used shall pass through a single central panel.
  - d. Connect 3 individual hoses:
    - 1) From the control panel to the pneumatic plugs for inflation,
    - 2) From the control panel to the sealed sewer line for introducing the low pressure air.
    - 3) From the sealed sewer line to the control panel for continually monitoring the air pressure rise in the sealed line.
3. Groundwater Conditions:
  - a. In areas where groundwater exists, and at the time of installing the sewer line, install a 1/2-inch diameter capped pipe nipple, approximately 10 inches long, through the manhole wall on top of one of the sewer lines entering the manhole.
  - b. Immediately prior to performing the line acceptance test, determine the height of groundwater by removing the groundwater test pipe cap, blowing air through the pipe nipple into the ground to clear it, and then connecting a clear plastic tube to the nipple.
  - c. Hold the tube vertically and measure the height in feet. Divide this height by 2.3 to establish the pounds of groundwater pressure to be added to the air pressure test readings. (Example: Height of water is 11-1/2 feet, added groundwater pressure is 5 psig, minimum air pressure is 3.5 psig; therefore, the total minimum acceptable pressure is 8.5 psig.)
4. Testing Pneumatic Plugs:
  - a. Seal test all pneumatic plugs prior to using them in the actual test.
  - b. Lay one length of pipe on the ground and seal both ends with the pneumatic plugs to be tested.
  - c. Pressurize the sealed pipe to 5 psig.
  - d. The pneumatic plugs are acceptable if they remain in place without bracing.

5. Testing Sewer Pipeline:
  - a. After the sewer pipe has been cleaned and the pneumatic plugs checked, place the plugs in the sewer line at each manhole and inflate them.
  - b. Introduce low-pressure air into the sealed sewer pipeline until the air pressure reaches 4 psig greater than the average groundwater pressure.
  - c. Allow a minimum of 2 minutes for the air pressure to stabilize to a minimum of 3.5 psig greater than the groundwater pressure.
  - d. After the stabilization period, disconnect the air hose from the control panel to the air supply.
  - e. The pipeline will be acceptable if the pressure decrease is not greater than 1/2 psig in the time stated in the following table.

TABLE 1

<u>Pipe Diameter (inches)</u>	<u>Minimum Time (min)</u>	<u>Length for Min Time (feet)</u>	<u>Time for Longer Lengths* (sec)</u>
4	1:53	597	.190L
6	2:50	398	.427L
8	3:47	298	.760L
10	4:43	239	1.187L
12	5:50	199	1.709L
15	7:05	159	2.671L
18	8:30	133	3.846L
21	9:55	114	5.235L
24	11:20	99	6.837L
27	12:45	88	8.653L
30	14:10	80	10.683L
33	15:35	72	12.926L
36	17:00	66	15.384L

\*Applies to pipe runs greater than those listed in column 3.  
L = Actual length of pipe being tested.

6. Test Results:
  - a. If the installation fails the low pressure air test, determine the source of leakage.
  - b. Replace all defective materials and/or workmanship and repeat low pressure test at no additional cost to the Owner.
  - c. Repairs shall only be made with prior approval of the Engineer in accordance with a method acceptable to the Engineer.

C. Alignment Tests (Gravity Sewers):

1. Perform tests for the correctness of horizontal and vertical alignment on each and every length of gravity sewer pipeline between manholes.
2. Beam a source of light, acceptable to the Engineer, through the pipe line and directly observe the light in the manhole at the opposite end of each test section.
3. Acceptance shall be determined by the Engineer and Owner.

D. Deflection Tests:

1. Deflection test all PVC pipe.
2. Perform test by using a deflectometer.
3. Maximum deflection: 5 percent.
4. Testing limits and test gauge diameter for plastic pipe:
  - a. Acceptance limit for deflection tests of installed flexible sewer pipe, listed in Table 2 shall be 5% of average inside diameter. A test shall be conducted after a minimum of thirty days following installation.

TABLE 2 - PVC Materials

D 3034	Solid Wall	4" - 15"
F 679	Solid Wall	18" - 36"
F 789	Solid Wall	4" - 18"
F 794	Ribbed Wall	18" - 48"
F 949	Corrugated	4" - 8"

- b. The deflection gauge diameter (G) for this test shall be determined by the following formula:

$$G = .929 D \text{ inches (nominal)}$$

where D is the average inside diameter given in the applicable ASTM standard. In the cases where inside diameters are not given they shall be determined by the following formula:

$$D = D' - 2(1.06 t) \text{ inches}$$

where t = the minimum solid wall thickness  
D' = the average outside diameter

- c. All PVC pipe is to be gauged and the results are to be recorded and the owner is to be provided written results.
- d. Limits of installed deflection for other flexible pipe materials shall not exceed the above for PVC.

END OF SECTION

SECTION 02930  
LOAM AND SEED

---

PART 1 - GENERAL

1.01 REFERENCES

- A. Examine all Drawings and all other Sections of the Specifications for requirements therein affecting the work of this trade.
- B. Coordinate work with that of all other trades affecting, or affected by work of this Section. Cooperate with such trades to assure the steady progress of all work under the Contract.

1.02 SCOPE

- A. The work of this Section consists of all lawn and fine grading work and related items as indicated on the Drawings and/or as specified herein, and includes, but is not limited to, the following:
  - 1. Fine grading
  - 2. Seeding
  - 3. Maintenance and protection

1.03 SUBMITTALS

- A. Samples: Prior to ordering the below listed materials, submit representative samples to the Engineer for selection and approval. Do not order materials until Engineer's approval has been obtained. Delivered materials shall match the approved samples.
  - 1. Existing Topsoil from Stockpile and Screened Loam: The Contractor shall provide representative samples for testing and approval. Two test samples of ten (10) pounds each shall be taken and analyzed from each potential loam source and two samples of ten (10) pounds each shall be taken and analyzed of existing screened topsoil stockpiled on site. Contractor shall deliver samples to testing laboratory, have testing reports sent directly to the Engineer, and pay all associated costs. Report shall be submitted at least one month before any loaming is to be done.
    - a. Mechanical and chemical (pH soluble salts) analysis shall be by a public extension service agency or a certified private testing laboratory in accordance with the current Standards of the Association of Official Agricultural Chemists.
    - b. Soil Test Report shall include a mechanical sieve analysis with soil classification. Organic content and Cation Exchange Capacity (CEC) shall be reported. Chemical analysis shall include pH (1:1

soil-water ratio), buffer pH, Soluble Salts (1:2 soil-water ratio), Nitrate Nitrogen, Ammonium Nitrogen, Phosphorus, Potassium, Calcium, Aluminum, Magnesium, Manganese, Ferric Iron and Sulfate.

- c. Soil test report shall clearly recommend appropriate limestone, fertilizer and other additives required to adjust loam as specified.
- B. Certificates of Compliance: Submit a manufacturer's Certificate of Compliance to the specifications with each shipment of each type of seed. These certificates shall include the guaranteed percentages of purity, weed content and germination of the seed and also the net weight and date of shipment. No seed may be sown until the Contractor has submitted the certificates.
- C. The Engineer reserves the right to approve or disapprove all samples submitted.

#### 1.04 CERTIFICATE OF ACCEPTANCE

- A. The Engineer will inspect all work upon the written request of the Contractor received at least ten (10) days before the anticipated date of inspection.
- B. Seeded lawns shall be reviewed for acceptance only after all areas have a close stand of grass with no bare spots greater than two (2) inches in diameter, at least 90% of the grass established shall be permanent grass species and the lawns have been maintained for a minimum of sixty (60) days prior to inspection.
- C. Engineer's inspection shall determine if the seeded lawns are acceptable and whether maintenance shall continue in any part.
- D. After all necessary corrective work and clean-up has been completed the Engineer will certify in writing the acceptance of the lawns. The Contractor's responsibility for maintenance of lawns or parts of lawns shall cease on receipt of the Certificate of Acceptance.

#### 1.05 EXAMINATION OF CONDITIONS

- A. All areas to be seeded shall be inspected by the Contractor before starting work and any defects, such as incorrect grading, drainage problems, etc., shall be reported to the Engineer prior to beginning this work. The commencement of work by the Contractor shall indicate his acceptance of the areas to be seeded, and he shall assume full responsibility for the work of this Section.

#### 1.06 QUALITY ASSURANCE

- A. Storage and Handling: Store and handle packaged materials in strict compliance with manufacturer's instructions and recommendations. Protect all materials from damage, injury and theft.

- B. Subcontractor Qualifications: Landscaping work shall be assigned to an experienced and qualified landscaping subcontractor with a minimum of five (5) years of experience who employs experienced workmen who work under the full time supervision of a qualified foreman.

PART 2 - PRODUCTS

2.01 TOPSOIL

- A. Topsoil shall be existing topsoil stripped and stockpiled under Section 02220 EXCAVATION, or as procured and delivered from an off-site source. Material shall consist of natural topsoil, free from subsoil, obtained from areas on site that have never been stripped. It shall be removed to its full depth. Topsoil shall be of uniform quality screened free of hard clods, stiff clay, hardpan, sods, partially disintegrated stone, lime, cement, ashes, slag, concrete, tar residues, tarred paper, boards, chips, glass, sticks, or any other undesirable material, and shall meet all requirements of screened loam specified herein below.

2.02 SCREENED LOAM

- A. Screened loam shall be a "sandy loam" determined by mechanical analysis and based on the USDA Textural Classification. It shall conform to the following grain size distribution for material passing the #4 sieve:

Material	% Passing
Sand	less than 52%
Silt	28%-50%
Clay	7%-27%

Soil test shall include breakdown of sand subfractions from course to very fine.

- B. Maximum grain size shall be one and one-quarter inches largest dimension. The maximum retained on the one-quarter inch sieve shall be 20 percent by weight of the total sample. Test shall be by combined hydrometer and wet sieving in compliance with ASTM D422 after destruction of organic matter by ignition.
- C. Screened loam shall be uncontaminated by salt, water, foreign matter and substances harmful to plant growth. The electrical conductivity ( $EC^2$ ) of a 1:2 soil-water suspension shall be equal to or less than 1.0 milliohms/cm. (Test material passing #4 sieve).
- D. Material shall consist of natural topsoil, free from subsoil, obtained from an area that has never been stripped. It shall be removed to a depth of one (1) foot or less if subsoil is encountered. Loam shall be of uniform quality screened free of hard clods, stiff clay, hardpan sods, partially disintegrated stone, lime, cement, ashes,

slag, concrete, tar residues, tarred paper, boards, chips, glass, sticks, or any other undesirable material.

- E. Screened loam shall have an acidity range of pH 6.0 to pH 7.0 and shall contain not less than 5% nor more than 10% organic matter as determined by the loss on ignition of oven-dried samples. Test samples shall be oven-dried to a constant weight at a temperature of 230°F plus or minus 9°F. To adjust organic matter content, the soil may be amended, prior to site delivery, by the addition of composted leaf mold or peat moss. Use of organic amendments is acceptable only if random soil sampling indicates thorough incorporation.
- F. Screened loam shall have a Cation Exchange Capacity (CEC) of between 10 and 15.
- G. All screened loam provided from off site sources shall be brought to the site meeting all specification requirements. The screened loam must not be handled or moved when in a wet or frozen condition.
- H. Screened topsoil which has been stockpiled on the site, may be used provided it can be made to comply with this Specification and that it has been screened to meet the above requirements.
- I. To assure screened loam fulfills requirements regarding textural analysis, organic matter content, CEC and pH, soil testing results will be obtained by the Contractor and submitted to the Engineer for approval before any soil is delivered to the site.

## 2.03 SOIL ADDITIVES

- A. Whenever possible soil deficiencies identified through soil analysis shall be corrected using natural products. In the event deficiencies cannot be corrected through amending with compost or other natural materials the Engineer shall be supplied with a description of fertilizers and additives, and rates of application proposed. The contractor shall not amend soil until Engineer's approval has been obtained.
- B. Commercial fertilizer shall be a product complying with State and United States Fertilizer Laws. Deliver to the site in the original unopened containers that shall bear the manufacturer's Certificate of Compliance covering analysis that shall be furnished to the Engineer. At least 50% by weight of the nitrogen content shall be derived from organic materials. Fertilizer shall contain not less than the percentages of weight of ingredients as follows, but shall be adjusted to meet all recommendations of the soil analysis.
- C. If this project or portions of this project fall within the jurisdiction of the New Hampshire Comprehensive Shoreline Protection Act (RSA 483-B), then, in accordance with this act, no fertilizer, except limestone, shall be used within 25



feet of the reference line of any property. Twenty-five feet beyond the reference line, low phosphate, slow release nitrogen fertilizer or limestone, may be used on lawns or areas with grass. A list of water bodies and rivers for which the act applies can be found at the NH DES website:

<http://des.nh.gov/organization/divisions/water/wetlands/cspa/index.htm>.

- D. Compost shall be mature, stable, weed free, and produced by aerobic decomposition of organic matter.
1. Compost shall be comprised of mature leaf compost, mature composted animal manure, other aged, composted vegetable materials, or chemically tested toxin-free processed sludge products safe for plants, humans and soil organisms. The product must not contain any visible refuse or other physical contaminants, substances toxic to plants, or over 5% sand, silt, clay or rock material by dry weight. The product shall possess no objectionable odors.
  2. The product must meet all applicable USEPA CFR, Title 40, Part 503 Standards for Class A biosolids. The moisture level shall be such that no visible water or dust is produced when handling the material. shall be dark brown in color, approximately the color of dark chocolate candy (70% chocolate). Black compost and compost the color of milk chocolate shall be rejected.
  3. Compost shall have a strong aerobic (sweet) odor. Compost lacking a strong aerobic odor or which has an anaerobic (sour), ammonia, or hydrogen sulfide odor shall be rejected.
  4. Compost shall be free from excessive amounts of zinc, low in wood content, free from hard lumps and in a shredded or granular form. According to the methods of testing of AOAC, latest edition, the acidity range shall be approximately 5.5 pH to 7.5 pH and the organic matter shall be not less than 85% as determined by loss on ignition. The minimum water absorbing ability shall be 200% by weight on an oven-dry basis.
  5. Compost shall contain no bulking agents, such as uncomposted wood chips, and shall be free from hard lumps and no plastic shall be present.
  6. Testing: The results of Compost analysis shall be provided by the Compost supplier. Before delivery of the Compost, the supplier must provide the following documentation:
    - a. Feedstock percentage in the final Compost product
    - b. A statement that the Compost meets federal and state health and safety regulations

7. Physical Requirements for Composted Organic Matter:

Parameter	Range	Testing Method
pH	5.5-7.5	TMECC 4.11A
Soluble Salt	< 4dS/m	TMECC 4.10-A
Moisture	35-55% wet weight	
Organic Matter	>85% dry weight	TMECC 5.07-A
Carbon to nitrogen ratio	15:1 -30:1	
Particle Size	99% pass through 2 inch screen or smaller; 25% pass through 3/8 inchscreen or smaller	TMECC 2.02-B
Maturity Index	6 to 8	Solvita
Physical contaminants	<1% dry weight basis	TMECC 3.08-A
Chemical contaminants	Meet or exceed US EPA Class A standard, 40 CFR § 503.13, Tables 1 and 3 levels:	
Arsenic	< 41ppm	TMECC 4.06-AS
Cadmium	< 39 ppm	TMECC 4.06-CD
Copper	< 1,500 ppm	TMECC 4.05-CU
Lead	< 300 ppm	TMECC 4.06-PB
Mercury	< 17 ppm	TMECC 4.06-HG
Molybdenum	< 75 ppm	TMECC 4.05-MO
Nickel	< 420 ppm	TMECC 4.06-NI
Selenium	< 100 ppm	TMECC 4.06-SE
Zinc	< 2,800 ppm	TMECC 4.06-ZN
Biological contaminants (pathogens)	Meet or exceed US EPA Class A standard, 40 CFR Part 503.32(a) levels:	
Fecal coliform	< 1,000 MPN per gram, dry weight basis	TMECC 7.01
Salmonella	< 3 MPN per 4 grams, dry	TMECC 7.02 dry

- E. The use of peat moss or other material the harvesting of which depletes natural wetlands may not be used.
- F. Bone meal shall be fine ground, steam cooked, packinghouse bone with a minimum analysis of 23% phosphoric acid and 4% nitrogen.
- G. Lime for adjustment of pH: An acceptable dolomite limestone containing not less than 85% of total carbonates, ground so that 50% will pass a 100 mesh sieve and 90% will pass a 20 mesh sieve.

## 2.04 SEED

- A. Seed mixture shall be fresh, clean, new crop seed. Grass shall be of the previous year's crop and in no case shall weed seed content exceed 1% by weight. The seed shall be furnished and delivered in the proportion specified below in new, clean, sealed and properly labeled containers. All seed shall comply with State and Federal seed laws. Submit manufacturer's Certificates of Compliance. Seed that has become wet, moldy or otherwise damaged is unacceptable.
- B. Lawn seed shall be composed of the following varieties that shall be mixed in the proportions and shall test to minimum percentages, purity and germination specified.

For Lawns	Proportion	Germination Minimum	Purity Minimum
Creeping Red Fescue or Chewings Fescue	50%	85%	95%
Kentucky Bluegrass (Flylking)	20%	90%	90%
Manhattan Perennial Rye	25%	90%	90%
Red Top	5%	85%	92%

- C. Seed may be mixed by an approved method on the site or may be mixed by a dealer. If the seed is mixed on site, each variety shall be delivered in the original containers bearing the dealer's guaranteed analysis. If the seed is mixed by a dealer, the Contractor shall furnish to the Engineer the dealer's guaranteed statement of the composition of the mixture.

## 2.05 HYDROMULCH

- A. Hydromulch shall be used as post-seeding protection mulch. Hydromulch shall not be the primary application method for seeding.
- B. Hydromulch shall be Mat-Blend Plus with Added Tackifier as manufactured by Mat Inc., 12402 Hwy. 2 Floodwood, MN 55736, (888)-477-3028 or approved equal.
- C. Hydromulch shall contain a pre-mixed a blend of whole wood fiber and clean recycled newsprint, plus 3% high-grade organic tackifier. It shall contain a specified range of fiber lengths, with a minimum of 30% of the fibers averaging 0.15 inches or longer. All matter shall be non-toxic to plant or animal life.

Ingredients	
Wood fiber content	60%-10%
Recycled clean paper content	40%-10%
Tackifier content by weight	3%
Basic green dye	<1%
Trade secret	<1%
Composition	
Organic matter	97%
Inorganic matter (ash) (max.)	3%
Moisture content (total weight base)	12%-3%
pH at 3% consistency in water slurry (avg.)	5.7
Water-holding capacity (min.)	1.2gal/lb.

1. The virgin wood fiber mulch shall contain no growth or germination-inhibiting factors, and shall be colored green with a non-toxic dye to facilitate visual monitoring during application. It shall disperse rapidly in water to form homogenous slurry, and remain in such a state when agitated in the hydraulic mulching unit with any other specified and approved materials.
2. The virgin wood fiber mulch and any specified additives, when applied, shall form an absorptive mat, but not a growth inhibiting membrane, to allow moisture, natural or mechanical, to percolate into the underlying soil.

D. Hydromulch shall meet the following specifications:

Moisture Content (total weight basis)	10.0% (3.0%)
Organic Water (o.d. weight basis)	99.04% (0.02%)
Inorganic Ash Content (o.d. weight basis)	0.96% (0.02%)
pH at 3% Consistency in Water	4.6
Water-Holding Capacity (o.d. weight basis)	1170g/100g
Tackifier Content (weight basis)	3%

E. Hydromulch Wood Fiber With Tackifier shall be applied at a rate of 1,200-1,500 pounds per acre on 3:1 slopes or flatter, or at 1,500-2,000 pounds per acre on slopes steeper than 3:1.

## 2.07 WATER

A. The Contractor shall be responsible for furnishing his own supply of water to the site at no extra cost. If possible, the City of Portsmouth will furnish the Contractor upon request with an adequate source and supply of water at no

charge. However, if the City's water supply is not available or not functioning or the irrigation system is not operable, the Contractor will be held responsible to furnish adequate supplies at his own cost. Any work injured or damaged due to the lack of water, or the use of too much water, shall be the Contractor's responsibility to correct. Water shall be free from impurities injurious to vegetation.

## PART 3 - EXECUTION

### 3.01 FINE GRADING AND LOAMING

- A. After the areas to be loamed have been brought to grade, and immediately prior to dumping and spreading the approved screened loam or screened topsoil, the subgrade shall be loosened by disking or rototilling to a depth of at least three inches to permit bonding of the loam to the subsoil. Remove from loosened subsoil all stones greater than two inches and all debris or rubbish from the loosened subsoil. Such material shall be removed from the site.
- B. Screened loam or screened topsoil from stockpile shall be placed and spread over approved areas to a depth sufficiently greater than six (6) inches so that after natural settlement and light rolling, the completed work will conform to the lines, grades, and elevations indicated. Supply additional loam, after testing and approval as may be needed, to give the specified depths and finished grades under the Contract without additional cost to the City.
- C. No subsoil or loam shall be handled in any way if it is in a wet or frozen condition.
- D. Sufficient grade stakes shall be set for checking the finished grades. Stakes must be set in the bottom of swales and at top of slopes. Grades shall be established which are accurate to one tenth of a foot either way. Connect contours and spot elevations with an even slope.
- E. After screened topsoil or screened loam has been spread, it shall be carefully prepared by hand raking. Screened loam shall also be free of smaller stones in excessive quantities as determined by the Engineer.
- F. The whole surface shall then be rolled with a hand roller weighing not more than 100 pounds per foot of width. During the rolling, all depressions caused by settlements or rolling shall be filled with additional loam and the surface shall be regraded and rolled until it presents a smooth and even finish to the required grade.
- G. Contractor shall obtain Engineer's written approval of fine grading and bed preparation before doing any seeding.

### 3.02 SEEDING

- A. Areas to be seeded shall be as indicated on the Drawings. All disturbed lawn areas outside the limit of seeding shall loamed and seeded only after approval of the Engineer.
- B. Seeding shall be done only during the period from April 1 to May 30 or August 15 to October 15. The actual planting of seed shall be done, however, only during periods within this season that are normal for such work as determined by weather conditions and by accepted practice in this locality. At his option, and on his responsibility, the Contractor may plant seed under unseasonable conditions at no increased cost to the City.
- C. Seed only when the bed is in a friable condition, not muddy or hard.
- D. Fertilizers shall only be applied after germination and shall not be a component of a slurry applied hydraulically.
- E. Seeding shall be done in two directions at right angles to each other. Sow the seed with an approved seeding device at the rate of ten pounds per 1000 square feet. No seeding shall be done in windy weather or as a component of a slurry applied hydraulically.
- F. If covering and rolling is not properly accomplished by the seeding machine, the seed shall be lightly raked into the ground, after which the ground shall be rolled with a five hundred pound roller and thoroughly and evenly watered with a fine spray to penetrate the soil to a depth of at least two (2) inches.
- G. After vegetation has appeared, reseed all areas and parts of areas, which fail to show a uniform stand of vegetation. Reseed repeatedly until all areas are satisfactorily covered. An established seeded area shall have a minimum count of 60 plants per square foot.
- H. In order to prevent unnecessary erosion of newly graded slopes and unnecessary siltation of drainage ways the Contractor shall carry out seeding and mulching as soon as he/she has satisfactorily completed a unit or portion of the project. A unit of the work will be defined as not more than 20,000 square feet.
- I. Erosion control matting shall be installed according to manufacturer's specifications in all drainage swales and all slopes of one vertical foot to three horizontal, or steeper, immediately after such areas have been seeded.

### 3.03 MAINTENANCE AND PROTECTION

- A. Maintenance shall begin immediately after any area is seeded, and shall continue until final written acceptance by the Engineer.

- B. Maintenance shall include reseeding, mowing, watering, weeding, liming and fertilizing.
- C. Watering of Seeded Areas:
1. First Week: The Contractor shall provide all labor and arrange for all watering necessary to establish an acceptable lawn. In the absence of an adequate rainfall, watering shall be performed daily or as often as necessary during the first week and in sufficient quantities to maintain moist soil to a depth of at least two (2) inches.
  2. Second and Subsequent Weeks: The Contractor shall water the lawn as required to maintain adequate moisture, in the upper two (2) inches of soil, necessary for the promotion of deep root growth.
  3. Watering shall be done in a manner that will provide uniform coverage, prevent erosion due to application of excessive quantities over small areas, and prevent damage to the finished surface by the watering equipment. The Contractor shall furnish sufficient watering equipment to apply one complete coverage to the seeded areas in an eight (8) hour period.
- D. Protection:
1. Seeded areas shall be protected by a three (3) foot high barrier constructed of two-by-four stakes or iron pipes set eighteen inches in the ground at ten (10) foot intervals and connected by No. 10 wire. Flags of white cloth shall be secured to the wire at center points between stakes.
  2. Barriers must be raised immediately after seeding and shall be maintained until acceptance.
- E. Reseeding: After the grass in seeded areas has appeared, all areas and parts of areas which, in the opinion of the Engineer, fail to show a uniform stand of grass, for any reason whatsoever, shall be reseeded and such areas and parts of areas shall be seeded repeatedly until all areas are covered with a satisfactory growth of grass. Reseeding together with necessary grading, fertilizing, and trimming shall be done at the expense of the Contractor.
- F. Mowing:
1. Seeded Areas: The Contractor shall keep seeded areas mowed until written acceptance of the seeding by the Engineer by cutting to a height of two (2") inches when growth reaches three (3") inches or as directed by the Engineer.
  2. Mowing shall include removal of clippings.
- G. Fertilizing: A second application of fertilizer, as specified herein, shall be applied after one (1) season of growth of a minimum of two (2) months duration, but only

during the months of April, May, August or September. Fertilizer shall be applied at the rate of thirty (30) pounds per one thousand (1,000) square feet.

- H. Liming: If more than one initial application of limestone is required by the soils analysis to bring the pH of the stockpiled topsoil/screened loam to a specified range, the Contractor shall be responsible for all additional required lime applications.

END OF SECTION



**DIVISION 3- CONCRETE**

- A. Formwork shall be clean, tightly joined together and well braced. Tie rods where required shall be smooth and of recognized type, the remains of which shall not be closer than 1" to the finished surface. All forms shall be maintained for a minimum of 24 hours after placing the concrete.
- B. Reinforcing bars shall be grade 60 (min) deformed, new billet steel meeting the requirements of ASTM a-615. All splices shall be lapped 30 diameter min. Reinforcing fabric for slabs shall be 6x6, W2.1xW2.1 E.W.W.M. conforming to ASTM a-185. All reinforcing shall be adequately tied, chaired, and secured in place before concrete placement starts. Refer to structural drawings.
- C. Set all necessary rods, anchor bolts, and/or dowels as required to tie together this and/or other existing work. Provide for penetrations in the concrete as required by the work of other trades. All pipes which must pass through concrete foundations shall have sleeves provided in the walls above the footings. Step footings down if necessary. Provide preformed joint fillers where indicated.
- D. Install vapor barriers and insulation, as provided under other divisions of this specification, where indicated on the drawings. Coordinate with other work.
- E. Drain all ponding water away from concrete pours through side channels to a sump area. Do not pump water directly from the formwork or elsewhere while concrete is being placed. Do not place concrete in temperatures of 40 degrees Fahrenheit or less. Do not use salt to thaw ice.
- F. Concrete shall be placed under direct supervision of the contractor and shall not be watered for speed of flow. Concrete shall be constantly rodded during placing to prevent honeycombing and thoroughly worked around all boxes or other obstructions in the forms. Internal vibrators may be used to secure dense, uniform concrete. The placing shall be one continuous uninterrupted process with concrete deposited as close to the area of use as possible. Avoid pushing concrete along forms and separating aggregate.
- G. Steel trowel all interior slab floors to a dense, smooth surface, and a true level plan with a tolerance of 1/4" variation in ten feet (max), except as noted otherwise. Saw cut control joints at 20 feet o.c. max. Moisture cure concrete for a minimum 7 days or apply a spray on curing agent immediately after forms are removed.

SECTION 03 3000

CAST-IN-PLACE CONCRETE

PART 1 GENERAL

1.01 SECTION INCLUDES

- A. Concrete formwork.
- B. Floors and slabs on grade.
- C. Concrete reinforcement.
- D. Joint devices associated with concrete work.
- E. Concrete curing.

1.02 SUBMITTALS

- A. Product Data: Submit manufacturers' data on manufactured products showing compliance with specified requirements and installation instructions.
- B. Product data for reinforcement, forming accessories, admixtures, patching compounds, waterstops, joint systems, curing compounds, dry-shake finish materials, and others as requested by Architect.
- C. Samples for Pigment Color Selection: Submit manufacturer's complete sample chip set, including

pigment number and required dosage rate for each color.

- D. Samples: Submit samples of underslab vapor retarder to be used.
- E. Manufacturer's Installation Instructions: For concrete accessories, indicate installation procedures and interface required with adjacent construction.
- F. Shop drawings for fabricating, bending, and placing concrete reinforcement.
- G. Laboratory test reports or evaluation reports for concrete materials and concrete mix designs.
- H. Written report to Architect for each proposed concrete mix at least 15 days prior to start of concreting. Do not begin concrete production until mixes have been reviewed by Architect.
- I. Project Record Documents: Accurately record actual locations of embedded utilities and components that will be concealed from view upon completion of concrete work.

### 1.03 QUALITY ASSURANCE

- A. Perform work of this section in accordance with ACI 301 and ACI 318, "Building Code Requirements for Reinforced Concrete," and CRSI "Manual of Standard Practice," except where more stringent requirements are indicated.
- B. Follow recommendations of ACI 305R when concreting during hot weather.
- C. Follow recommendations of ACI 306R when concreting during cold weather.
- D. Concrete Testing Service: Engage a testing agency acceptable to Architect to perform materials evaluation testing and to design concrete mixes.
  - 1. Materials certificates signed by concrete producer and Contractor may be submitted in lieu of materials laboratory testing when acceptable to Architect.

## PART 2 PRODUCTS

### 2.01 FORMWORK

- A. Form Materials: Contractor's choice of standard products with sufficient strength to withstand hydrostatic head without distortion in excess of permitted tolerances.
  - 1. Form Facing for Exposed Finish Concrete: Contractor's choice of materials that will provide smooth, stain-free final appearance.
  - 2. Form Coating: Release agent that will not adversely affect concrete or interfere with application of coatings.

### 2.02 REINFORCEMENT

- A. Reinforcing Steel: ASTM A 615/A 615M Grade 60 (420) unless otherwise indicated.
  - 1. Type: Deformed billet-steel bars.
  - 2. Finish: Unfinished, unless otherwise indicated.
- B. Steel Welded Wire Reinforcement: ASTM A 185/A 185M, plain type.
  - 1. Form: Coiled Rolls.
  - 2. Mesh Size: 6 x 6
- C. Reinforcement Accessories:
  - 1. Tie Wire: Annealed, minimum 16 gage.
  - 2. Chairs, Bolsters, Bar Supports, Spacers: Sized and shaped for adequate support of reinforcement during concrete placement.
  - 3. Provide stainless steel, galvanized, plastic, or plastic coated steel components for placement within 1-1/2 inches of weathering surfaces.

### 2.03 CONCRETE MATERIALS

- A. Cement: ASTM C150, Type II - Normal Portland type.

1. Acquire all cement for entire project from same source.
- B. Fine and Coarse Aggregates: ASTM C 33. Except local aggregates of proven durability may be used when acceptable to Architect.
  1. Acquire all aggregates for entire project from same source.
- C. Fly Ash: ASTM C618, Class C or F.
- D. Water: Clean and not detrimental to concrete.
- E. Fiber Reinforcement: Alkali-resistant polypropylene complying with ASTM C1116/C1116M.

#### 2.04 CHEMICAL ADMIXTURES

- A. Do not use chemicals that will result in soluble chloride ions in excess of 0.1 percent by weight of cement.
- B. Air Entrainment Admixture: ASTM C260.
- C. Water Reducing and Accelerating Admixture: ASTM C494/C494M Type E.
- D. Accelerating Admixture: ASTM C494/C494M Type C.

#### 2.05 ACCESSORY MATERIALS

- A. Underslab Vapor Retarder: Multi-layer, fabric-, cord-, grid-, or aluminum-reinforced, 10-mil polyethylene or equivalent, complying with ASTM E 1745, Class A; stated by manufacturer as suitable for installation in contact with soil or granular fill under concrete slabs. Single ply polyethylene is prohibited.
  1. Accessory Products: Vapor retarder manufacturer's recommended tape, adhesive, mastic, prefabricated boots, etc., for sealing seams and penetrations in vapor retarder.

#### 2.06 BONDING AND JOINTING PRODUCTS

- A. Latex Bonding Agent: Non-redispersable acrylic latex, complying with ASTM C1059 Type II.
  1. Products:
    - a. W.R. Meadows, Inc.; ACRY-LOK-: [www.wrmeadows.com](http://www.wrmeadows.com).
- B. Slab Isolation Joint Filler: 3/8 inch thick, height equal to slab thickness, with removable top section that will form 1/2 inch deep sealant pocket after removal.
  1. Material: ASTM D1752 sponge rubber (Type I).
- C. Joint Filler: Nonextruding, resilient asphalt impregnated fiberboard or felt, 1/4 inch thick and 4 inches deep; tongue and groove profile.

#### 2.07 CURING MATERIALS

- A. Evaporation Reducer: Liquid thin-film-forming compound that reduces rapid moisture loss caused by high temperature, low humidity, and high winds; intended for application immediately after concrete placement.
- B. Curing and Sealing Compound, Low Gloss: Liquid, membrane-forming, clear, non-yellowing acrylic; complying with ASTM C1315 Type 1 Class A.

#### 2.08 CONCRETE MIX DESIGN

- A. Proportioning Normal Weight Concrete: Comply with ACI 211.1 recommendations.
- B. Proportioning Structural Lightweight Concrete: Comply with ACI 211.2 recommendations.
- C. Concrete Strength: Establish required average strength for each type of concrete on the basis of field experience or trial mixtures, as specified in ACI 301.
  1. For trial mixtures method, employ independent testing agency acceptable to the Architect for preparing and reporting proposed mix designs.

- D. Admixtures: Add acceptable admixtures as recommended in ACI 211.1 and at rates recommended by manufacturer.
- E. Fiber Reinforcement: Add to mix at rate of 1.5 pounds per cubic yard, or as recommended by manufacturer for specific project conditions.
- F. Normal Weight Concrete:
  - 1. Compressive Strength, when tested in accordance with ASTM C39/C39M at 28 days: 3,000 psi.
  - 2. Fly Ash Content: Maximum 15 percent of cementitious materials by weight.
  - 3. Water-Cement Ratio: Maximum 40 percent by weight.
  - 4. Total Air Content: 4 percent, determined in accordance with ASTM C173/C173M.
  - 5. Maximum Slump: 3 inches.

## 2.09 MIXING

- A. Transit Mixers: Comply with ASTM C94/C94M.
- B. Limit use of fly ash to not exceed 25 percent of cement content by weight.
- C. Limit maximum water-cement ratio of concrete exposed to freezing and thawing to 0.50.
- D. Slump Limits: Proportion and design mixes to result in concrete slump at point of placement as follows:
  - 1. Ramps, Slabs, and Sloping Surfaces: Not more than 3 inches (6" with MRWR).
  - 2. Reinforced Foundation Systems: Not less than 1 inch and not more than 4 inches (6" with MRWR).
  - 3. Other Concrete: Not more than 4 inches (6" with MRWR).
- E. Adjust mix designs when material characteristics, job conditions, weather, test results, or other circumstances warrant. Do not use revised concrete mixes until laboratory test data and strength results have been submitted to and reviewed by Architect.
- F. Use mid-range water reducer (MRWR) in all concrete except footings.
- G. Use air-entraining admixture in exterior exposed concrete, providing not less than 4.5 percent nor more than 7 percent entrained air for concrete exposed to freezing and thawing, and from 2 percent to 4 percent for other concrete.
- H. Use water-reducing, accelerating, and retarding admixtures that have been tested and accepted in mix designs in strict compliance with manufacturer's directions.

## PART 3 EXECUTION

### 3.01 EXAMINATION

- A. Verify lines, levels, and dimensions before proceeding with work of this section.

### 3.02 PREPARATION

- A. Formwork: Comply with requirements of ACI 301. Design and fabricate forms to support all applied loads until concrete is cured, and for easy removal without damage to concrete.
- B. Verify that forms are clean and free of rust before applying release agent. Apply form-release agents or wet forms as required. Retighten forms during concrete placement, if required, to eliminate mortar leaks.
- C. Provide openings in formwork to accommodate work of other trades. Accurately place and securely support items built into forms.
- D. Coordinate placement of embedded items with erection of concrete formwork and placement of form accessories.
- E. Where new concrete is to be bonded to previously placed concrete, prepare existing surface by

cleaning with steel brush and applying bonding agent in accordance with manufacturer's instructions.

1. Use latex bonding agent only for non-load-bearing applications.

F. Interior Slabs on Grade: Install vapor retarder under interior slabs on grade. Lap joints minimum 6 inches. Seal joints, seams and penetrations watertight with manufacturer's recommended products and follow manufacturer's written instructions. Repair damaged vapor retarder before covering.

### 3.03 INSTALLING REINFORCEMENT AND OTHER EMBEDDED ITEMS

A. Comply with requirements of ACI 301. Clean reinforcement of loose rust and mill scale, and accurately position, support, and secure in place to achieve not less than minimum concrete coverage required for protection.

B. Install welded wire reinforcement in maximum possible lengths, and offset end laps in both directions. Splice laps with tie wire.

C. Verify that anchors, seats, plates, reinforcement and other items to be cast into concrete are accurately placed, positioned securely, and will not interfere with concrete placement.

### 3.04 PLACING CONCRETE

A. Place concrete in accordance with ACI 304R.

B. Place concrete for floor slabs in accordance with ACI 302.1R.

C. Notify the Architect not less than 24 hours prior to commencement of placement operations.

D. Maintain records of concrete placement. Record date, location, quantity, air temperature, and test samples taken.

E. Ensure reinforcement, inserts, embedded parts, and formed construction joint devices will not be disturbed during concrete placement.

F. Place concrete continuously without construction (cold) joints wherever possible; where construction joints are necessary, before next placement prepare joint surface by removing laitance and exposing the sand and sound surface mortar, by sandblasting or high-pressure water jetting.

G. Finish floors level and flat, unless otherwise indicated, within the tolerances specified below.

### 3.05 SLAB JOINTING

A. Locate joints as indicated on the drawings.

B. Anchor joint fillers and devices to prevent movement during concrete placement.

C. Isolation Joints: Use preformed joint filler with removable top section for joint sealant, total height equal to thickness of slab, set flush with top of slab.

D. Saw Cut Contraction Joints: Saw cut joints before concrete begins to cool, within 4 to 12 hours after placing; use 3/16 inch thick blade and cut at least 1 inch deep but not less than one quarter (1/4) the depth of the slab.

E. Installation of Embedded Items: Set and build anchorage devices and other embedded items required for other work that is attached to or supported by cast-in-place concrete. Use setting diagrams, templates, and instructions provided by others for locating and setting.

F. Concrete Placement: Comply with ACI 304, "Guide for Measuring, Mixing, Transporting, and Placing Concrete," for placing concrete in a continuous operation within planned joints or sections. Do not begin concrete placement until other affected work is completed.

1. Consolidate placed concrete using mechanical vibrating equipment with hand rodding and tamping so that concrete is worked around reinforcement and other embedded items and into forms.

2. Protect concrete from physical damage or reduced strength due to weather extremes

during mixing, placing, and curing.

- a. In cold weather comply with ACI 306.
- b. In hot weather comply with ACI 305.

### 3.06 SEPARATE FLOOR TOPPINGS

- A. Apply bonding agent to substrate in accordance with manufacturer's instructions.

### 3.07 FLOOR FLATNESS AND LEVELNESS TOLERANCES

A. Maximum Variation of Surface Flatness:

1. Exposed Concrete Floors: 1/8 inch in 10 ft.

B. Correct the slab surface if tolerances are less than specified.

C. Correct defects by grinding or by removal and replacement of the defective work. Areas requiring corrective work will be identified. Re-measure corrected areas by the same process.

### 3.08 CONCRETE FINISHING

A. Concrete Slabs: Finish to requirements of ACI 302.1R, and as follows:

1. Decorative Exposed Surfaces: Exposed concrete shall be sanded and sealed to expose aggregate.
2. Other Surfaces to Be Left Exposed: "Steel trowel" as described in ACI 302.1R, minimizing burnish marks and other appearance defects.

### 3.09 CURING AND PROTECTION

A. Comply with requirements of ACI 308R. Immediately after placement, protect concrete from premature drying, excessively hot or cold temperatures, and mechanical injury.

B. Maintain concrete with minimal moisture loss at relatively constant temperature for period necessary for hydration of cement and hardening of concrete.

1. Normal concrete: Not less than 7 days.

C. Formed Surfaces: Cure by moist curing with forms in place for full curing period.

D. Absorptive Cover: Burlap cloth made from jute or kenaf, weighing approximately 9 oz. per sq. yd., complying with AASHTO M 182, Class 2.

E. Moisture-Retaining Cover: Waterproof paper, polyethylene film, or polyethylene-coated burlap, complying with ASTM C 171.

F. Membrane-Forming Curing Compound: ASTM C 309, Type I. Moisture loss not more than 0.55 kg/sq. meter when applied at 200 sq. ft./gal.

G. Evaporation Control: Monomolecular film-forming compound applied to exposed concrete slab surfaces for temporary protection from rapid moisture loss.

H. Surfaces Not in Contact with Forms:

1. Slabs and Floors To Receive Adhesive-Applied Flooring: Curing compounds and other surface coatings are usually considered unacceptable by flooring and adhesive manufacturers. If such materials must be used, either obtain the approval of the flooring and adhesive manufacturers prior to use or remove the surface coating after curing to flooring manufacturer's satisfaction.
2. Initial Curing: Start as soon as free water has disappeared and before surface is dry. Keep continuously moist for not less than three days by water ponding, water-saturated sand, water-fog spray, or saturated burlap.
3. Final Curing: Begin after initial curing but before surface is dry.

### 3.10 FIELD QUALITY CONTROL

A. Provide free access to concrete operations at project site and cooperate with appointed firm.

B. Submit proposed mix design of each class of concrete to inspection and testing firm for review

- prior to commencement of concrete operations.
- C. Tests of concrete and concrete materials may be performed at any time to ensure conformance with specified requirements.
  - D. Compressive Strength Tests: ASTM C39/C39M. For each test, mold and cure three concrete test cylinders. Obtain test samples for every 100 cu yd or less of each class of concrete placed.
  - E. Take one additional test cylinder during cold weather concreting, cured on job site under same conditions as concrete it represents.
  - F. Perform one slump test for each set of test cylinders taken, following procedures of ASTM C143/C143M.
  - G. Sampling Fresh Concrete: ASTM C 172, except modified for slump to comply with ASTM C 94.
    - 1. Slump: ASTM C 143; one test at point of discharge for each day's pour of each type of concrete; additional tests when concrete consistency seems to have changed.
    - 2. Air Content: ASTM C 173, volumetric method for lightweight or normal weight concrete; ASTM C 231, pressure method for normal weight concrete; one for each day's pour of each type of air-entrained concrete.
    - 3. Concrete Temperature: ASTM C 1064; one test hourly when air temperature is 40 deg F (4 deg C) and below, when 80 deg F (27 deg C) and above, and one test for each set of compressive-strength specimens.
    - 4. Compression Test Specimen: ASTM C 31; one set of four standard cylinders for each compressive-strength test, unless otherwise directed. Mold and store cylinders for laboratory-cured test specimens except when field-cured test specimens are required.
      - a. Then number of tests are to be determined by scope of work and as required by testing agency.
      - b. Compressive-Strength Tests: ASTM C 39; one set for each day's pour exceeding 5 cu. yd. plus additional sets for each 50 cu. yd. more than the first 25 cu. yd. of each concrete class placed in any one day; one specimen tested at 7 days, two specimens tested at 28 days, and one specimen retained in reserve for later testing if required.
  - H. When frequency of testing will provide fewer than five strength tests for a given class of concrete, conduct testing from at least five randomly selected batches or from each batch if fewer than five are used.
  - I. When total quantity of a given class of concrete is less than 50 cu. yd., Architect may waive strength testing if adequate evidence of satisfactory strength is provided.
  - J. When strength of field-cured cylinders is less than 85 percent of companion laboratory-cured cylinders, evaluate current operations and provide corrective procedures for protecting and curing the in-place concrete.
  - K. Strength level of concrete will be considered satisfactory if averages of sets of three consecutive strength test results equal or exceed specified compressive strength and no individual strength test result falls below specified compressive strength by more than 500 psi.
  - L. Test results will be reported in writing to Architect, Structural Engineer, ready-mix producer, and Contractor within 24 hours after tests. Reports of compressive strength tests shall contain the Project identification name and number, date of concrete placement, name of concrete testing service, concrete type and class, location of concrete batch in structure, design compressive strength at 28 days, concrete mix proportions and materials, compressive breaking strength, and type of break for both 7-day tests and 28-day tests.
  - M. Nondestructive Testing: Impact hammer, sonoscope, or other nondestructive device may be permitted but shall not be used as the sole basis for acceptance or rejection.
  - N. Additional Tests: The testing agency will make additional tests of in-place concrete when test results indicate specified concrete strengths and other characteristics have not been attained in the structure, as directed by Architect. Testing agency may conduct tests to determine adequacy of concrete by cored cylinders complying with ASTM C 42, or by other methods as directed.

3.11 DEFECTIVE CONCRETE

- A. Test Results: The testing agency shall report test results in writing to the Architect and Contractor within 24 hours of test.
- B. Defective Concrete: Concrete not conforming to required lines, details, dimensions, tolerances or specified requirements.
- C. Repair or replacement of defective concrete will be determined by the Architect. The cost of additional testing shall be borne by Contractor when defective concrete is identified.
- D. Do not patch, fill, touch-up, repair, or replace exposed concrete except upon express direction of the Architect for each individual area.

3.12 PROTECTION

- A. Do not permit traffic over unprotected concrete floor surface until fully cured.
- 

**DIVISION 4- MASONRY**

- A. All face brick is noted on the drawings and shall be installed as recommended by the brick institute of America for the applications shown.
- B. Exposed masonry work shall be thoroughly washed and cleaned with clear water and fiber brush to remove mortar stains, dirt, etc.
- C. Provide flashing as required.

SECTION 042000 - UNIT MASONRY

PART 1 - GENERAL

1.01 RELATED DOCUMENTS

- A. Drawings and general provisions of the Contract, including General and Supplementary Conditions and Division 01 Specification Sections, apply to this Section.

1.02 SUMMARY

- A. This Section includes unit masonry assemblies consisting of the following:
  - 1. Concrete masonry units (CMUs).
  - 2. Decorative concrete masonry units.
  - 3. Concrete brick.
  - 4. Mortar and grout.
  - 5. Reinforcing steel.
  - 6. Masonry joint reinforcement.
  - 7. Ties and anchors.
  - 8. Miscellaneous masonry accessories.
  - 9. Air/vapor barrier at pool.
  - 10. Masonry waste disposal.
- B. Products installed, but not furnished, under this Section include the following:
  - 1. Steel lintels for unit masonry, furnished under Division 05 Section "Metal Fabrications."



2. Manufactured reglets in masonry joints for metal flashing, furnished under Division 07 Section "Sheet Metal Flashing and Trim."
3. Steel frames in unit masonry openings, furnished under Division 08 Section "Hollow Metal Doors and Frames."
4. Installation of access doors in masonry openings furnished under Division 08 Section "Access Doors and Frames."

### 1.03 DEFINITIONS

- A. Reinforced Masonry: Masonry containing reinforcing steel in grouted cells.

### 1.04 PERFORMANCE REQUIREMENTS

- A. Provide unit masonry that develops indicated net-area compressive strengths ( $f_m$ ) at 28 days.

### 1.05 SUBMITTALS

- A. General: Submit in accordance with Division 01 Section 013300 "Submittal Procedures".
- B. Product Data: For each type of product indicated.
- C. Shop Drawings: For the following:
  1. Masonry Units: Show sizes, profiles, coursing, and locations of special shapes.
  2. Reinforcing Steel: Detail fabrication, bending and placement of unit masonry reinforcing bars. Comply with ACI 315, "Details and Detailing of Concrete Reinforcement." Show elevations of reinforced walls.
- D. Qualification Data: For firms and persons specified in "Quality Assurance" Article.
- E. Material Certificates: Include statements of material properties indicating compliance with requirements including compliance with standards and type designations within standards. Provide for each type and size of the following:
  1. Masonry units.
    - a. Include material test reports substantiating compliance with requirements.
    - b. For masonry units used in structural masonry, include data and calculations establishing average net-area compressive strength of units.
  2. Cementitious materials. Include brand, type, and name of manufacturer.
  3. Preblended, dry mortar mixes. Include description of type and proportions of ingredients.
  4. Grout mixes. Include description of type and proportions of ingredients.
  5. Reinforcing bars.
  6. Joint reinforcement.
- F. Submit samples of sand to an approved laboratory for tests. Submit test report for approval.
- G. Cold-Weather Procedures: Detailed description of methods, materials, and equipment to be used to comply with cold-weather requirements.

### 1.06 QUALITY ASSURANCE

- A. Installer Qualifications: Company specializing in performing the work of this Section with minimum 5 years experience.

- B. Source Limitations for Masonry Units: Obtain exposed masonry units of a uniform texture and color, or a uniform blend within the ranges accepted for these characteristics, through one source from a single manufacturer for each product required.
- C. Source Limitations for Mortar Materials: Obtain mortar ingredients of a uniform quality, including color for exposed masonry, from a single manufacturer for each cementitious component and from one source or producer for each aggregate.  
Preconstruction Testing Service: Employ and pay a qualified independent testing agency to perform the following tests to establish compliance of proposed materials with specified requirements:
  - 1. Concrete Masonry Unit Test: For each type of unit required, test units for strength, absorption, and moisture content per ASTM C 140.
  - 2. Mortar Test: For each mix required, test for composition and properties per ASTM C 780.
  - 3. Grout Test (Compressive Strength): For each mix required, per ASTM C 1019.
- D. Preinstallation Conference: Conduct conference at Project site with the Architect.

#### 1.07 DELIVERY, STORAGE, AND HANDLING

- A. Store masonry units on elevated platforms in a dry location. If units are not stored in an enclosed location, cover tops and sides of stacks with waterproof sheeting, securely tied. If units become wet, do not install until they are dry.
  - 1. Protect Type I concrete masonry units from moisture absorption so that, at the time of installation, the moisture content is not more than the maximum allowed at the time of delivery.
- B. Store cementitious materials on elevated platforms, under cover, and in a dry location. Do not use cementitious materials that have become damp.
- C. Store aggregates where grading and other required characteristics can be maintained and contamination avoided.
- D. Store masonry accessories, including metal items, to prevent corrosion and accumulation of dirt and oil.

#### 1.08 PROJECT CONDITIONS

- A. Protection of Masonry: During construction, cover tops of walls, projections, and sills with waterproof sheeting at end of each day's work. Cover partially completed masonry when construction is not in progress.
  - 1. Extend cover a minimum of **24 inches** down both sides and hold cover securely in place.
  - 2. Where 1 wythe of multiwythe masonry walls is completed in advance of other wythes, secure cover a minimum of **24 inches** down face next to unconstructed wythe and hold cover in place.
- B. Do not apply uniform floor or roof loads for at least 12 hours and concentrated loads for at least 3 days after building masonry walls or columns.

- C. Stain Prevention: Prevent grout, mortar, and soil from staining the face of masonry to be left exposed or painted. Immediately remove grout, mortar, and soil that come in contact with such masonry.
1. Protect base of walls from rain-splashed mud and from mortar splatter by spreading coverings on ground and over wall surface.
  2. Protect sills, ledges, and projections from mortar droppings.
  3. Protect surfaces of window and door frames, as well as similar products with painted and integral finishes, from mortar droppings.
  4. Turn scaffold boards near the wall on edge at the end of each day to prevent rain from splashing mortar and dirt onto completed masonry.
- D. Cold-Weather Requirements: Do not use frozen materials or materials mixed or coated with ice or frost. Do not build on frozen substrates. Remove and replace unit masonry damaged by frost or by freezing conditions. Comply with cold-weather construction requirements contained in ACI 530.1/ASCE 6/TMS 602 and the following:
1. Cold-Weather Construction: When the ambient temperature is within the limits indicated, use the following procedures:
    - a. 40 to 32 degrees F: Heat mixing water or sand to produce mortar and grout temperatures between 40 and 120 degrees F.
    - b. 32 to 25 degrees F: Heat mixing water and sand to produce mortar temperatures between 40 and 120 degrees F. Heat grout materials to produce grout temperatures between 40 and 120 degrees F. Maintain mortar and grout above freezing until used in masonry.
    - c. 25 to 20 degrees F: Heat mixing water and sand to produce mortar temperatures between 40 and 120 degrees F. Heat grout materials to produce grout temperatures between 40 and 120 degrees F. Maintain mortar and grout above freezing until used in masonry. Heat masonry units to 40 degrees F if grouting. Use heat on both sides of walls under construction.
    - d. 20 degrees F and below: Heat mixing water and sand to produce mortar temperatures between 40 and 120 degrees F. Heat grout materials to produce grout temperatures between 40 and 120 degrees F. Maintain mortar and grout above freezing until used in masonry. Heat masonry units to 40 degrees F. Provide enclosures and use heat on both sides of walls under construction to maintain temperatures above 32 degrees F within the enclosures.
  2. Cold-Weather Protection: When the mean daily temperature is within the limits indicated, provide the following protection, this is in addition to construction procedures specified above:
    - a. 40 to 25 degrees F: Cover masonry insulating blankets for 48 hours after construction.
    - b. 25 degrees F and below: Provide enclosure and heat to maintain temperatures above 32 degrees F within the enclosure for 72 hours after construction.
  3. Cold-Weather Cleaning: Use liquid cleaning methods only when air temperature is **40 deg F** and above and will remain so until masonry has dried, but not less than 7 days after completing cleaning.
- E. Hot-Weather Requirements: Protect unit masonry work when temperature and humidity conditions produce excessive evaporation of water from mortar and grout. Provide artificial shade and wind breaks and use cooled materials as required.
1. When ambient temperature exceeds **100 deg F**, or **90 deg F** with a wind velocity greater than **8 mph**, do not spread mortar beds more than **48 inches** ahead of masonry. Set masonry units within one minute of spreading mortar.

2. Do not apply mortar to substrates with temperatures of 100 deg F and above.

## PART 2 - PRODUCTS

### 2.01 MANUFACTURERS

- A. In other Part 2 articles where titles below introduce lists, the following requirements apply to product selection:
  1. Products: Subject to compliance with requirements, provide one of the products specified, or equal.
  2. Manufacturers: Subject to compliance with requirements, provide products by one of the manufacturers specified, or equal.

### 2.02 MASONRY UNITS, GENERAL

- A. Defective Units: Referenced masonry unit standards may allow a certain percentage of units to exceed tolerances and to contain chips, cracks, or other defects exceeding limits stated in the standard. Do not use units where such defects, including dimensions that vary from specified dimensions by more than stated tolerances, will be exposed in the completed Work or will impair the quality of completed masonry.

### 2.03 CONCRETE MASONRY UNITS (CMUs)

- A. Shapes: Provide shapes indicated and as follows:
  1. Provide special shapes for lintels, corners, jambs, sashes, movement joints, headers, bonding, and other special conditions.
  2. Provide bullnose units for outside corners, unless otherwise indicated.
- B. Concrete Masonry Units: ASTM C 90. CMU1
  1. Unit Compressive Strength: Provide units with minimum average net-area compressive strength of 1900 psi.
  2. Weight Classification: Normal weight.
  3. Size (Width): Manufactured to dimensions 3/8 inch less than nominal dimensions.
  4. Exposed Faces: Provide color and texture matching existing construction.

### 2.04 MASONRY LINTELS

- A. Masonry Lintels: Prefabricated or built-in-place masonry lintels made from bond beam concrete masonry units with reinforcing bars placed as indicated and filled with coarse grout. Cure precast lintels before handling and installing. Temporarily support built-in-place lintels until cured.

### 2.05 MORTAR AND GROUT MATERIALS

- A. Portland Cement: ASTM C 150, Type I or II, except Type III may be used for cold-weather construction.
- B. Hydrated Lime: ASTM C 207, Type S.
- C. Portland Cement-Lime Mix: Packaged blend of Portland Cement complying with ASTM C 150, Type I or Type III, and hydrated lime complying with ASTM C 207, Type S.
  1. Product: Eaglebond; Blue Circle Cement, Inc.

2. Standard masonry cement is not acceptable.

D. Aggregate for Mortar: ASTM C 144.

E. Aggregate for Grout: ASTM C 404.

F. Cold-Weather Admixture: Not allowed.

G. Water Repellent Admixture: Liquid water repellent admixture intended for use with CMUs containing integral water repellent by same manufacturer.

1. Products: Subject to compliance with requirements, available products that may be incorporated into the Work include, but are not limited to, the following:

a. ACM Chemestries; RainBloc for Mortar

b. BASF Aktiengesellschaft; Rheopel Mortar Admixture

c. Grace Construction Products, W.R. Grace & Co.; Dry-Block Mortar Admixture

H. Water: Potable.

## 2.06 REINFORCEMENT

A. Uncoated Steel Reinforcing Bars: ASTM A 615/A 615M, **Grade 60**.

B. Deformed Reinforcing Wire: ASTM A 496, with ASTM A 153, Class B-2 zinc coating.

## 2.07 MASONRY JOINT REINFORCEMENT

A. Masonry Joint Reinforcement, General: ASTM A 951.

1. Exterior and Interior Walls: Hot-dip galvanized, carbon steel, except as noted.

2. Spacing of Cross Rods, Tabs, and Cross Ties: Not more than **16 inches** o.c.

3. Provide in lengths of not less than **10 feet**, with prefabricated corner and tee units.

B. Masonry Joint Reinforcement for Single-Wythe Masonry: See wall section drawing A10

## 2.08 MISCELLANEOUS ANCHORS

A. Anchor Bolts: Steel bolts, bent in configuration indicated, complying with **ASTM A 307, Grade A**; with **ASTM A 563** hex nuts and, where indicated, flat washers; hot-dip galvanized to comply with ASTM A 153, Class C; of dimensions indicated.

B. Postinstalled Anchors: Provide chemical or torque-controlled expansion anchors, with capability to sustain, without failure, a load equal to six times the load imposed when installed in solid or grouted unit masonry and equal to four times the load imposed when installed in concrete, as determined by testing per ASTM E 488 conducted by a qualified independent testing agency.

1. Corrosion Protection: Carbon-steel components zinc plated to comply with ASTM B 633, Class Fe/Zn 5 (5 microns) for Class SC 1 service condition (mild).

2. Corrosion Protection: Stainless-steel components complying with **ASTM F 593 and ASTM F 594, Alloy Group 1 or 2** for bolts and nuts; ASTM A 666 or ASTM A 276, Type 304 or 316, for anchors.

a. Location: Provide at Pool.

2.09 MISCELLANEOUS MASONRY ACCESSORIES

- A. Compressible Filler: Premolded filler strips complying with ASTM D 1056, Type 2, Class A, Grade 1; compressible up to 35 percent; of width and thickness indicated; formulated from neoprene, urethane, or PVC.
- B. Preformed Control-Joint Gaskets: Made from styrene-butadiene-rubber compound, complying with ASTM D 2000, Designation M2AA-805 or PVC, complying with ASTM D 2287, Type PVC-65406 and designed to fit standard sash block and to maintain lateral stability in masonry wall; size and configuration as indicated.
- C. Bond-Breaker Strips: Asphalt-saturated, organic roofing felt complying with ASTM D 226, Type I (No. 15 asphalt felt).
- D. Reinforcing Bar Positioners: Wire units designed to fit into mortar bed joints spanning masonry unit cells with loops for holding reinforcing bars in center of cells. Units are formed from **0.142-inch** steel wire, hot-dip galvanized after fabrication. Provide units with either two loops or four loops as needed for number of bars indicated.
  - 1. Products:
    - a. Dayton Superior Corporation, Dur-O-Wal Division; D/A 810, D/A 812 or D/A 817.
    - b. Heckmann Building Products Inc.; No. 376 Rebar Positioner.
    - c. Hohmann & Barnard, Inc.; #RB or #RB-Twin Rebar Positioner.
    - d. Wire-Bond; O-Ring or Double O-Ring Rebar Positioner.

2.10 MASONRY CLEANERS

- A. Job-Mixed Detergent Solution: Solution of **1/2-cup** dry measure tetrasodium polyphosphate (Spic and Span) and **1/2-cup** dry measure laundry detergent dissolved in **1 gal.** of water.

2.11 MORTAR AND GROUT MIXES

- A. General: Do not use admixtures, including pigments, air-entraining agents, accelerators, retarders, water-repellent agents, antifreeze compounds, or other admixtures, unless otherwise indicated.
  - 1. Do not use calcium chloride in mortar or grout.
  - 2. Limit cementitious materials in mortar for exterior and reinforced masonry to portland cement and lime.
- B. Mortar for Unit Masonry: Comply with BIA Technical Notes 8A, Proportion Specification. Provide the following types of mortar for applications stated unless another type is indicated or needed to provide required compressive strength of masonry.
  - 1. For reinforced masonry, use Type S.
- C. Grout for Unit Masonry: Comply with ASTM C 476.
  - 1. Use grout of type indicated or, if not otherwise indicated, of type (fine or coarse) that will comply with Table 1.15.1 in ACI 530.1/ASCE 6/TMS 602 for dimensions of grout spaces and pour height.
  - 2. Provide grout with a slump of **8 to 11 inches** as measured according to ASTM C 143/C 143M.

2.12 SOURCE QUALITY CONTROL

- A. Engage a qualified independent testing agency to perform source quality-control testing indicated below and submit test reports to Architect:
- B. Concrete Masonry Unit Test: For each type of unit furnished, per ASTM C 140.

PART 3 - EXECUTION

3.01 EXAMINATION

- A. Examine conditions, with Installer present, for compliance with requirements for installation tolerances and other conditions affecting performance of work.
  - 1. If unsatisfactory conditions are encountered, prepare written report, endorsed by Installer, listing conditions detrimental to performance of work.
  - 2. Verify that foundations are within tolerances specified.
  - 3. Verify that reinforcing dowels are properly placed.
- B. Before installation, examine rough-in and built-in construction for piping and electrical systems to verify actual locations of piping and conduit connections.
- C. Proceed with installation only after unsatisfactory conditions have been corrected.

3.02 INSTALLATION, GENERAL

- A. Thickness: Build masonry construction to full thickness shown. Build single-wythe walls to actual widths of masonry units, using units of widths indicated.
- B. Build chases and recesses to accommodate items specified in this and other Sections.
- C. Leave openings for equipment to be installed before completing masonry. After installing equipment, complete masonry to match the construction immediately adjacent to opening.
- D. Use full-size units without cutting if possible. If cutting is required to provide a continuous pattern or to fit adjoining construction, cut units with motor-driven saws; provide clean, sharp, unchipped edges. Allow units to dry before laying, unless wetting of units is specified. Install cut units with cut surfaces and, where possible, cut edges concealed.
- E. Select and arrange units for exposed unit masonry to produce a uniform blend of colors and textures.
  - 1. Mix units from several pallets or cubes as they are placed.
- F. Comply with construction tolerances in ACI 530.1/ASCE 6/TMS 602 and with the following:
  - 1. For conspicuous vertical lines, such as external corners, door jambs, reveals, and expansion and control joints, do not vary from plumb by more than **1/8 inch in 10 feet**, **1/4 inch in 20 feet**, or **1/2 inch** maximum.
  - 2. For vertical alignment of exposed head joints, do not vary from plumb by more than **1/4 inch in 10 feet**, or **1/2 inch** maximum.
  - 3. For conspicuous horizontal lines, such as lintels, sills, parapets, and reveals, do not vary from level by more than **1/8 inch in 10 feet**, **1/4 inch in 20 feet**, or **1/2 inch** maximum.

4. For exposed bed joints, do not vary from thickness indicated by more than plus or minus **1/8 inch**, with a maximum thickness limited to **1/2 inch**. Do not vary from bed-joint thickness of adjacent courses by more than **1/8 inch**.
5. For exposed head joints, do not vary from thickness indicated by more than plus or minus **1/8 inch**. Do not vary from adjacent bed-joint and head-joint thicknesses by more than **1/8 inch**.
6. For faces of adjacent exposed masonry units, do not vary from flush alignment by more than **1/16 inch** except due to warpage of masonry units within tolerances specified for warpage of units.
7. For exposed bed joints and head joints of stacked bond, do not vary from a straight line by more than **1/16 inch** from one masonry unit to the next.

### 3.03 LAYING MASONRY WALLS

- A. Lay out walls in advance for accurate spacing of surface bond patterns with uniform joint thicknesses and for accurate location of openings, movement-type joints, returns, and offsets. Avoid using less-than-half-size units, particularly at corners, jambs, and, where possible, at other locations.
- B. Bond Pattern for Masonry: Unless otherwise indicated, lay masonry in running bond, centered on head joint below; do not use units with less than nominal **4-inch** horizontal face dimensions at corners or jambs.
- C. Stopping and Resuming Work: Stop work by racking back units in each course from those in course below; do not tooth. When resuming work, clean masonry surfaces that are to receive mortar, remove loose masonry units and mortar.
- D. Built-in Work: As construction progresses, build in items specified in this and other Sections. Fill in solidly with masonry around built-in items.
- E. Fill space between steel frames, bent plate frames, and masonry solidly with mortar, unless otherwise indicated. Grout cores solid minimum of 16-inches each side of openings.
- F. Where built-in items are to be embedded in cores of hollow masonry units, place a layer of metal lath, wire mesh, or plastic mesh in the joint below and rod mortar or grout into core.
- G. Fill cores in hollow concrete masonry units with grout **24 inches** under bearing plates, beams, lintels, posts, and similar items, unless otherwise indicated.
- H. Build non-load-bearing interior partitions full height of story to underside of solid floor or roof structure above, unless otherwise indicated.
  1. Install compressible filler in joint between top of partition and underside of structure above.

### 3.04 MORTAR BEDDING AND JOINTING

- A. Lay hollow concrete masonry units as follows:
  1. With face shells fully bedded in mortar and with head joints of depth equal to bed joints.
  2. With webs fully bedded in mortar in all courses of piers, columns, and pilasters.
  3. With webs fully bedded in mortar in grouted masonry, including starting course on footings.
  4. With entire units, including areas under cells, fully bedded in mortar at starting course on footings where cells are not grouted.



- B. Tool exposed joints slightly concave when thumbprint hard, using a jointer larger than joint thickness, unless otherwise indicated.

### 3.05 MASONRY JOINT REINFORCEMENT

- A. General: Install entire length of longitudinal side rods in mortar with a minimum cover of **5/8 inch** on exterior side of walls, **1/2 inch** elsewhere. Lap reinforcement a minimum of **6 inches**.
  - 1. Space reinforcement not more than **16 inches** o.c.
  - 2. Provide reinforcement not more than **8 inches** above and below wall openings and extending **12 inches** beyond openings.
    - a. Reinforcement above is in addition to continuous reinforcement.
- B. Interrupt joint reinforcement at control and expansion joints, unless otherwise indicated.
- C. Provide continuity at wall intersections by using prefabricated T-shaped units.
- D. Provide continuity at corners by using prefabricated L-shaped units.
- E. Cut and bend reinforcing units as directed by manufacturer for continuity at corners, returns, offsets, column fireproofing, pipe enclosures, and other special conditions.

### 3.06 CONTROL AND EXPANSION JOINTS

- A. General: Install control and expansion joint materials in unit masonry as masonry progresses. Do not allow materials to span control and expansion joints without provision to allow for in-plane wall or partition movement.
- B. Form control joints in concrete masonry as follows:
  - 1. Install preformed control-joint gaskets designed to fit standard sash block.

### 3.07 LINTELS

- A. Install steel lintels where indicated.
- B. Provide masonry lintels where shown and where openings of more than **24 inches (610 mm)** for block-size units are shown without structural steel or other supporting lintels.
  - 1. Provide built-in-place masonry lintels. Use specially formed bond beam units with reinforcing bars placed as indicated and filled with coarse grout. Temporarily support built-in-place lintels until cured.
- C. Provide minimum bearing of **8 inches** at each jamb, unless otherwise indicated.

### 3.08 REINFORCED UNIT MASONRY INSTALLATION

- A. Temporary Formwork and Shores: Construct formwork and shores as needed to support reinforced masonry elements during construction.
  - 1. Construct formwork to provide shape, line, and dimensions of completed masonry as indicated. Make forms sufficiently tight to prevent leakage of mortar and grout. Brace, tie, and support forms to maintain position and shape during construction and curing of reinforced masonry.
  - 2. Do not remove forms and shores until reinforced masonry members have hardened sufficiently to carry their own weight and other temporary loads that may be placed on them during construction.

- B. Bracing of Walls During Construction: Provide temporary lateral bracing of masonry walls to prevent collapse in accordance with NCMA-TEC 72 and applicable OSHA standards. Contractor is solely responsible for the design and adequacy of bracing methods used.
- C. Placing Reinforcement: Comply with requirements in ACI 530.1/ASCE 6/TMS 602 and the requirements indicated on the structural drawings.
- D. Grouting: Do not place grout until entire height of masonry to be grouted has attained enough strength to resist grout pressure.
  - 1. Comply with requirements in ACI 530.1/ASCE 6/TMS 602 for cleanouts and for grout placement, including minimum grout space and maximum pour height.
  - 2. Definitions:
    - a. Grout Lift: Grout placed in one continuous operation. The maximum time span for the grout placement in one lift is 1-1/2 hours measured from the time water is added to the grout mix. The minimum time span between successive grout lifts is one hour.
    - b. Grout Pour: The height of masonry to be grouted prior to the erection of additional masonry.
  - 3. See drawing S0.0 for additional requirements.
  - 4. Consolidate grout with a mechanical vibrator.
    - a. Use a low velocity vibrator with a 3/4- inch head.
    - b. Vibrate each cell in concrete masonry units twice. Insert vibrator to bottom of lift and activate for 1 to 2 seconds.
    - c. Perform initial consolidation at each cell immediately after grout placement.
    - d. Perform reconsolidation in each cell by reinserting vibrator when grout is still plastic.
  - 5. Interior of block cells shall be dry before grouting operations occur to facilitate proper absorption of water from grout. Wet or saturated surface dry conditions are not allowed, and shall be allowed to fully dry before grout placement.

### 3.09 FIELD QUALITY CONTROL

- A. The Contractor shall employ a testing agency approved by the Construction Manager to perform tests and to submit test reports to Architect. The independent inspection agency shall perform testing, inspect, evaluate, prepare test reports and verify conformance with special inspections as described in the 2006 IBC International Building Code. See Division 01 Section 014000 "Quality Requirements" for additional requirements.
- B. Testing Frequency: One set of tests for each 5000 sq. ft. of wall area or portion thereof.
- C. Concrete Masonry Unit Test: For each type of unit provided, per ASTM C 140.
- D. Mortar Test (Property Specification): For each mix provided, per ASTM C 780.
- E. Grout Test (Compressive Strength): For each mix provided, per ASTM C 1019.
- F. Prism Test: For each type of construction provided, per ASTM C 1314; one set at 7 days and one at 28 days.
- G. Evaluation of Quality-Control Tests: In the absence of other indications of noncompliance with requirements, masonry will be considered satisfactory if results from construction quality-control tests comply with minimum requirements indicated.

- H. Inspect cores and clean-out holes before grout is placed.

### 3.10 REPAIRING, POINTING, AND CLEANING

- A. Remove and replace masonry units that are loose, chipped, broken, stained, or otherwise damaged or that do not match adjoining units. Install new units to match adjoining units; install in fresh mortar, pointed to eliminate evidence of replacement.
- B. Pointing: During the tooling of joints, enlarge voids and holes, except weep holes, and completely fill with mortar. Point up joints, including corners, openings, and adjacent construction, to provide a neat, uniform appearance. Prepare joints for sealant application, where indicated.
- C. In-Progress Cleaning: Clean unit masonry as work progresses by dry brushing to remove mortar fins and smears before tooling joints.
  - 1. Clean concrete masonry by cleaning method indicated in NCMA TEK 8-2A applicable to type of stain on exposed surfaces.
- D. Protection: Provide final protection and maintain conditions that ensure unit masonry is without damage and deterioration at time of Substantial Completion.

### 3.11 MASONRY WASTE DISPOSAL

- A. Salvageable Materials: Unless otherwise indicated, excess masonry materials are Contractor's property. At completion of unit masonry work, remove from Project site.

---

## DIVISION 6- WOOD, PLASTICS, AND COMPOSITES

- A. All general framing lumber shall be no. 2 or better. Spruce- pine- fir, surfaced four sides, graded and marked in accordance with the Northeastern Lumber Manufacturer's Association. Maximum moisture content shall be 19%. See the drawings for framing members' sizes and use. Minimum allowable stresses: extreme fiber in bending,  
Fb = 875 psi tension parallel to grain, ft = 450 psi  
Compression parallel to grain, fc = 1,150 psi  
Modulus of elasticity, e = 1,400,000 psi
- B. All plywood shall meet the provisions of U.S. Product Standard PS 1 (latest edition) and shall be in accordance with the American Plywood Association performance standards. Each sheet of plywood shall be stamped with the grade information appropriate to the intended application. Particle or flake board will not be accepted.
- C. All lumber material exposed to the weather or in contact with concrete or masonry shall be pressure treated.
- D. Provide all rough hardware including nails, screws, framing anchors, hangers, clips and other related items to complete the work. Framing anchors and joist hangers shall be of 18 ga. Galvanized steel min, installed with hanger nails and comply with IBC standards. Provide aluminum ply-clips and all unblocked edges of roof sheathing, two per bay min.
- E. Rough carpentry and framing standards, except as noted otherwise, shall comply with the "Manual of House Framing" by the National Forest Products Association, including fastenings, fire stopping, bracing, anchorages, bridging, etc. All such work shall be laid out as indicated on the drawings and shall be accurately cut and tightly fitted as necessitated by conditions encountered. Rough opening dimensions for all prefabricated components shall be verified by the contractor from manufacturer's

literature. All work shall be plumbed, leveled, and secured with sufficient nails, spikes, bolts, etc. To ensure rigidity. Provide blocking required by the work of other trades. Plywood subfloors shall be installed in accordance with the APA glued floor system.

- F. Furnish labor and materials to properly close up all openings during the progress of the work. Temporary doors may be provided with padlock which can be closed and secured when the building is vacant.
- G. All new exterior siding and/or interior paneling and trim shall be as noted on the drawings.
- H. All new finish carpentry and millwork shall be as noted on the drawings and shaped, joined, and installed in accordance with the quality standards of the Architectural Woodwork Institute, "Custom Grade".

Clean woodwork and fill nail holes in preparation for the required finishes. Where woodwork is to receive a transparent finish, use filler material matching wood fiber. All work shall be machine or hand sanded so as to remove all marks left by machine dressing and other roughness, and shall be left in proper condition or painting.

## SECTION 06 1000 ROUGH CARPENTRY

### PART 1 GENERAL

#### 1.01 SECTION INCLUDES

- A. Non-structural dimension lumber framing.
- B. Rough opening framing for doors, windows, and roof openings.
- C. Wall sheathing.
- D. Subflooring.
- E. Underlayment.
- F. Roof-mounted curbs.
- G. Roofing nailers.
- H. Preservative treated wood materials.
- I. Fire retardant treated wood materials.
- J. Miscellaneous framing and sheathing.
- K. Communications and electrical room mounting boards.
- L. Concealed wood blocking, nailers, and supports.
- M. Miscellaneous wood nailers, furring, and grounds.
- N. Water-resistive barrier over wall sheathing.

#### 1.02 SUBMITTALS

- A. Product Data for engineered wood products, underlayment, insulating sheathing, air-infiltration barriers, metal framing anchors, and construction adhesives.
- B. Material certificates for dimension lumber specified to comply with minimum allowable unit

stresses.

- C. Wood treatment data, including chemical treatment manufacturer's instructions for handling, storing, installing, and finishing treated materials.
- D. Manufacturer's Certificate: Certify that wood products supplied for rough carpentry meet or exceed specified requirements.

### 1.03 DELIVERY, STORAGE, AND HANDLING

- A. General: Cover wood products to protect against moisture. Support stacked products to prevent deformation and to allow air circulation.

## PART 2 PRODUCTS

### 2.01 GENERAL REQUIREMENTS

- A. Dimension Lumber: Comply with DOC PS 20 and requirements of specified grading agencies with applicable grading rules of inspection agencies certified by the American Lumber Standards Committee's (ALSC) Board of Review. Provide dressed lumber, S4S, with each piece factory marked with grade stamp of inspection agency.
  - 1. For exposed lumber, furnish pieces with grade stamps applied to ends or back of each piece, or omit grade stamps and provide grade-compliance certificates issued by inspection agency.
  - 2. Provide dry lumber with 19 percent maximum moisture content at time of dressing for 2-inch nominal (38-mm actual) thickness or less, unless otherwise indicated.
- B. Lumber fabricated from old growth timber is not permitted.

### 2.02 DIMENSION LUMBER FOR CONCEALED APPLICATIONS

- A. Dimension Lumber: Provide dimension lumber of grades indicated according to the ALSC National Grading Rule (NGR) provisions of the inspection agency indicated.
  - 1. Non-Load-Bearing Interior Partitions: Provide Standard, Stud, or No. 3 grade and any of the following species:
    - a. Species: Eastern softwoods; NELMA.
    - b. Species: Northern species; NLGA.
  - 2. Framing Other than Non-Load-Bearing Partitions: Provide No. 2 grade or better of the following species:
    - a. Species: Spruce-pine-fir, NLGA..

### 2.03 MISCELLANEOUS LUMBER:

- A. Provide No. 3 or Standard grade lumber of any species for support or attachment of other construction, including rooftop equipment curbs and support bases, cant strips, bucks, nailers, blocking, and similar members.

### 2.04 ENGINEERED WOOD PRODUCTS:

- A. Engineered Wood Products: Acceptable to authorities having jurisdiction and for which current

model code research or evaluation reports exist that evidence compliance with building code in effect for Project. Provide engineered wood products with allowable design stresses, as published by manufacturer that meet or exceed those indicated. Manufacturer's published values shall be determined from empirical data or by rational engineering analysis, and demonstrated by comprehensive testing performed by a qualified independent testing agency.

1. Parallel-Strand Lumber: Lumber manufactured by laying up wood strands using an exterior-type adhesive complying with ASTM D 2559, and cured under pressure to produce members with grain of strands parallel to their lengths and complying with the following requirements:
  - a. Extreme Fiber Stress in Bending: 2900 psi for 12-inch nominal depth members.
  - b. Modulus of Elasticity: 2,000,000 psi.
2. Laminated-Strand Lumber: Lumber manufactured by laying up wood strands using an exterior-type adhesive complying with ASTM D 2559, and cured under pressure to produce members with grain of strands parallel to their lengths and complying with the following requirements:
  - a. Extreme Fiber Stress in Bending: 2250 psi for 12-inch nominal depth members.
  - b. Modulus of Elasticity: 1,500,000 psi.
3. Laminated-Veneer Lumber: Lumber manufactured by laminating wood veneers in a continuous press using an exterior-type adhesive complying with ASTM D 2559 to produce members with grain of veneers parallel to their lengths and complying with the following requirements:
  - a. Extreme Fiber Stress in Bending: 3080 psi for 12-inch nominal depth members.
  - b. Modulus of Elasticity: 2,000,000 psi
4. Wood I-Joists: Prefabricated units, I-shaped in cross section, made with solid or structural composite lumber flanges and wood-based structural panel webs, let into and bonded to flanges. Provide units complying with material requirements of and with structural capacities established and monitored according to ASTM D 5055.
  - a. Structural Properties: Provide units with depths and design values not less than those indicated. If alternate joist manufacturer is proposed, provide equal or greater strength and stiffness values to specified joist.

## 2.07 WOOD-BASED STRUCTURAL-USE PANELS:

- A. Provide either all-veneer, mat-formed, or composite panels complying with DOC PS 2, "Performance Standard for Wood-Based Structural-Use Panels," unless otherwise indicated. Provide plywood panels complying with DOC PS 1, "U.S. Product Standard for Construction and Industrial Plywood," where plywood is indicated.
  1. Trademark: Factory mark structural-use panels with APA trademark evidencing compliance with grade requirements.
  2. Span Ratings: Provide panels with span ratings required to suit support spacing indicated.
  3. Wall Sheathing: APA-rated sheathing, Exposure 1.
  4. Roof Sheathing: APA-rated sheathing, Exposure 1
  5. Plywood Backing Panels: For mounting electrical or telephone equipment, provide fire-retardant-treated plywood panels with grade, C-D Plugged Exposure 1, in thickness indicated or, if not otherwise indicated, not less than 15/32 inch (11.9 mm) thick
  6. Plywood Underlayment for Resilient Flooring: APA B-C Underlayment Exterior plywood panels with fully sanded face.
  7. Plywood Underlayment for Carpet: APA Underlayment Exposure 1 plywood panels with fully sanded face.

## 2.09 EXPOSED BOARDS

- A. Submit manufacturer's certificate that products meet or exceed specified requirements, in lieu of grade stamping.
- B. Moisture Content: Kiln-dry (15 percent maximum).
- C. Surfacing: S4S.
- D. Species: Douglas Fir.
- E. Grade: No. 2, 2 Common, or Construction.

## 2.10 CONSTRUCTION PANELS

- A. Subfloor/Underlayment Combination: See structural drawings.
- B. Roof Sheathing: See structural drawings.
- C. Wall Sheathing: See structural drawings.
- D. Communications and Electrical Room Mounting Boards: PS 1 A-D plywood, or medium density fiberboard; 3/4 inch thick; flame spread index of 25 or less, smoke developed index of 450 or less, when tested in accordance with ASTM E84.

## 2.11 ACCESSORIES

- A. Fasteners: Size and type indicated. Where rough carpentry is exposed to weather, in ground contact, in contact with pressure treated lumber, or in area of high relative humidity, provide fasteners with a hot-dip zinc coating per ASTM A 153 or of Type 304 stainless steel.
  - 1. Metal and Finish: Hot-dipped galvanized steel per ASTM A 153/A 153M for high humidity and preservative-treated wood locations, unfinished steel elsewhere.
  - 2. Power-Driven Fasteners: CABO NER-272.
  - 3. Bolts: Steel bolts complying with ASTM A 307, Grade A (ASTM F 568, Property Class 4.6); with ASTM A 563 (ASTM A 563M) hex nuts and, where indicated, flat washers.
- B. Metal Framing Anchors: Provide galvanized steel framing anchors of structural capacity, type, and size indicated and as follows:
  - 1. Research or Evaluation Reports: Provide products for which model code research or evaluation reports exist that are acceptable to authorities having jurisdiction and that evidence compliance of metal framing anchors for application indicated with building code in effect for Project.
  - 2. Allowable Design Loads: Provide products with allowable design loads, as published by manufacturer, that meet or exceed those indicated. Manufacturer's published values shall be determined from empirical data or by rational engineering analysis, and demonstrated by comprehensive testing performed by a qualified independent testing agency.
  - 3. Galvanized Steel Sheet: Hot-dip, zinc-coated steel sheet complying with ASTM A 653, G185 coating designation; structural, commercial, or lock-forming quality, as standard with manufacturer for type of anchor indicated.
- C. Air-Infiltration Barrier: Air retarder complying with ASTM E 1677; made from polyolefins; either cross-laminated films, woven strands, or spunbonded fibers; coated or uncoated; with or without perforations to transmit water vapor but not liquid water; and with minimum water-vapor transmission of 10 perms (575 ng/Pa x s x sq. m) when tested according to ASTM E 96, Procedure A.
- D. Sill-Sealer Gaskets: Glass-fiber-resilient insulation, fabricated in strip form, for use as a sill

sealer; 1-inch (25-mm) nominal thickness, compressible to 1/32 inch (0.8 mm); selected from manufacturer's standard widths to suit width of sill members indicated.

- E. Adhesives for Field Gluing Panels to Framing: Formulation complying with APA AFG-01 that is approved for use with type of construction panel indicated by both adhesive and panel manufacturers.
- F. Sill Flashing: As specified in Section 07 6200.
- G. Subfloor Glue: Waterproof, water base, air cure type, cartridge dispensed.
- H. Water-Resistive Barrier: No. 15 asphalt felt.
- I. Building Paper: Water-resistant Kraft paper.

## 2.12 FACTORY WOOD TREATMENT

- A. Treated Lumber and Plywood: Comply with requirements of AWPA U1 - Use Category System for wood treatments determined by use categories, expected service conditions, and specific applications.
  - 1. Preservative-Treated Wood: Provide lumber and plywood marked or stamped by an ALSC-accredited testing agency, certifying level and type of treatment in accordance with AWPA standards.
- B. Preservative Pressure Treatment of Lumber Above Grade: AWPA U1, Use Category UC3B, Commodity Specification A using waterborne preservative to 0.25 lb/cu ft retention.
  - 1. Pressure treat above ground items with waterborne preservatives to a minimum retention of 0.25 lb/cu. ft. (4.0 kg/cu. m). After treatment, kiln-dry lumber and plywood to a maximum moisture content of 19 and 15 percent, respectively. Treat indicated items and the following:
    - a. Wood cants, nailers, curbs, equipment support bases, blocking, stripping, and similar members in connection with roofing, flashing, vapor barriers, and waterproofing.
    - b. Wood sills, sleepers, blocking, furring, stripping, and similar concealed members in contact with masonry or concrete.
    - c. Wood framing members less than 18 inches (460 mm) above grade.
    - d. Wood floor plates installed over concrete slabs directly in contact with earth.

## PART 3 EXECUTION

### 3.01 PREPARATION

- A. Where wood framing bears on cementitious foundations, install full width sill flashing continuous over top of foundation, lap ends of flashing minimum of 4 inches and seal.
- B. Install sill gasket under sill plate of framed walls bearing on foundations; puncture gasket cleanly to fit tightly around protruding anchor bolts.
- C. Coordinate installation of rough carpentry members specified in other sections.

### 3.02 INSTALLATION - GENERAL

- A. Select material sizes to minimize waste.



- B. Reuse scrap to the greatest extent possible; clearly separate scrap for use on site as accessory components, including: shims, bracing, and blocking.
- C. Where treated wood is used on interior, provide temporary ventilation during and immediately after installation sufficient to remove indoor air contaminants.
- D. Air-Infiltration Barrier: Cover sheathing with air-infiltration barrier to comply with manufacturer's written instructions.
  - 1. Apply air-infiltration barrier to cover upstanding flashing with 4-inch (100-mm) overlap

### 3.03 FRAMING INSTALLATION

- A. Set structural members level, plumb, and true to line. Discard pieces with defects that would lower required strength or result in unacceptable appearance of exposed members.
- B. Make provisions for temporary construction loads, and provide temporary bracing sufficient to maintain structure in true alignment and safe condition until completion of erection and installation of permanent bracing.
- C. Fit rough carpentry to other construction; scribe and cope as required for accurate fit. Correlate location of furring, nailers, blocking, grounds, and similar supports to allow attachment of other construction.
- D. Install structural members full length without splices unless otherwise specifically detailed.
- E. Comply with member sizes, spacing, and configurations indicated, and fastener size and spacing indicated, but not less than required by applicable codes and AFPA Wood Frame Construction Manual.
- F. Securely attach rough carpentry work to substrate by anchoring and fastening as indicated, complying with the following:
  - 1. Published requirements of metal framing anchor manufacturer.
  - 3. "Table 2304.9.1--Fastening Schedule" of the 2009 IBC.
- G. Use hot-dip galvanized or stainless-steel nails where rough carpentry is exposed to weather, in ground contact, in contact with pressure treated lumber, or in area of high relative humidity.
- H. Install horizontal spanning members with crown edge up and not less than 1-1/2 inches of bearing at each end.
- I. Countersink nail heads on exposed carpentry work and fill holes with wood filler.
- J. Construct double joist headers at floor and ceiling openings and under wall stud partitions that are parallel to floor joists; use metal joist hangers unless otherwise detailed.
- K. Installation of Structural-Use Panels: Comply with applicable recommendations contained in APA Form No. E30, "APA Design/Construction Guide: Residential & Commercial," for types of structural-use panels and applications indicated.
  - 1. Comply with "Code Plus" provisions of above-referenced guide.
  - 2. Fastening Methods: Fasten panels as indicated below:
    - a. Combination Subflooring-Underlayment: Glue and nail to framing throughout.
    - b. Subflooring: Glue and nail to framing throughout.
    - c. Sheathing: Nail to framing.
    - d. Underlayment: Nail or staple to subflooring.
  - 3. Air-Infiltration Barrier: Cover sheathing with air-infiltration barrier to comply with manufacturer's written instructions.
    - a. Apply air-infiltration barrier to cover upstanding flashing with 4-inch overlap.

M. Frame wall openings with two or more studs at each jamb; support headers on cripple studs.

### 3.04 BLOCKING, NAILERS, AND SUPPORTS

- A. Provide framing and blocking members as indicated or as required to support finishes, fixtures, specialty items, and trim.
- B. In framed assemblies that have concealed spaces, provide solid wood fireblocking as required by applicable local code, to close concealed draft openings between floors and between top story and roof/attic space; other material acceptable to code authorities may be used in lieu of solid wood blocking.
- C. In walls, provide blocking attached to studs as backing and support for wall-mounted items, unless item can be securely fastened to two or more studs or other method of support is explicitly indicated.
- D. Specifically, provide the following non-structural framing and blocking:
  - 1. Cabinets and shelf supports.
  - 2. Wall brackets.
  - 3. Handrails.
  - 4. Grab bars.
  - 5. Towel and bath accessories.
  - 6. Wall-mounted door stops.
  - 7. Chalkboards and marker boards.
  - 8. Wall paneling and trim.
  - 9. Joints of rigid wall coverings that occur between studs.

### 3.05 ROOF-RELATED CARPENTRY

- A. Coordinate installation of roofing carpentry with deck construction, framing of roof openings, and roofing assembly installation.

### 3.06 INSTALLATION OF CONSTRUCTION PANELS

- A. Subflooring/Underlayment Combination: Glue and nail to framing; staples are not permitted.
- B. Subflooring: Glue and nail to framing; staples are not permitted.
- C. Underlayment: Secure to subflooring with nails and glue.
  - 1. At locations where resilient flooring will be installed, fill and sand splits, gaps, and rough areas.
  - 2. Place building paper between floor underlayment and subflooring.
- D. Roof Sheathing: Secure panels with long dimension perpendicular to framing members, with ends staggered and over firm bearing.
  - 1. At long edges use sheathing clips where joints occur between roof framing members.
  - 2. Nail panels to framing; staples are not permitted.
- E. Wall Sheathing: Secure with long dimension perpendicular to wall studs, with ends over firm bearing and staggered, using nails.
  - 1. Use plywood or other acceptable structural panels at building corners, for not less than 96 inches, measured horizontally.
  - 2. Provide inlet diagonal bracing at corners.
  - 3. Place water-resistive barrier horizontally over wall sheathing, weather lapping edges and ends.

- F. Communications and Electrical Room Mounting Boards: Secure with screws to studs with edges over firm bearing; space fasteners at maximum 24 inches on center on all edges and into studs in field of board.
1. At fire-rated walls, install board over wall board indicated as part of the fire-rated assembly.
  2. Where boards are indicated as full floor-to-ceiling height, install with long edge of board parallel to studs.
  3. Install adjacent boards without gaps.
  4. Size and Location: As indicated on drawings.

### 3.07 TOLERANCES

- A. Framing Members: 1/4 inch from true position, maximum.
- B. Variation from Plane (Other than Floors): 1/4 inch in 10 feet maximum, and 1/4 inch in 30 feet maximum.

### 3.08 CLEANING

- A. Waste Disposal: Comply with the requirements of Section 01 7419.
1. Comply with applicable regulations.
  2. Do not burn scrap on project site.
  3. Do not burn scraps that have been pressure treated.
  4. Do not send materials treated with pentachlorophenol, CCA, or ACA to co-generation facilities or "waste-to-energy" facilities.
- B. Do not leave any wood, shavings, sawdust, etc. on the ground or buried in fill.
- C. Prevent sawdust and wood shavings from entering the storm drainage system.

## SECTION 06170 WOOD TRUSSES

### PART 1 GENERAL

#### 3.12 SUMMARY

- A. This Section includes the following:
1. Triangular-pitched roof trusses.
  2. Girder trusses.
  3. Truss accessories.
- B. Related Sections: The following Sections contain requirements that relate to this Section:
1. Division 6 Section "Rough Carpentry" for roof and floor sheathing of structural-use panels and dimension lumber for supplementary framing and permanent bracing.

#### 3.13 DEFINITIONS

- A. Metal-plate-connected wood trusses include planar structural units consisting of metal-plate-connected members fabricated from dimension lumber and cut and assembled before delivery to Project site.

### 3.14 PERFORMANCE REQUIREMENTS

- A. Structural Performance: Engineer, fabricate, and erect metal-plate-connected wood trusses to withstand design loads within limits and under conditions required.
  - 1. Design Loads: As indicated on plans.
  - 2. Design trusses to withstand design loads without deflections greater than the following:
    - a. Roof Trusses: Vertical deflection of  $L/480$  of span due to snow/live load.
    - b. Floor Trusses: Vertical deflection of  $L/480$  of span due to live load and vertical deflection of  $L/360$  of span due to total load. Live load deflection shall not exceed 1 inch.
- B. Engineering Responsibility: Engage a fabricator who uses a qualified professional structural engineer licensed in the State of New Hampshire to prepare calculations, Shop Drawings, and other structural data for metal-plate-connected wood trusses.

### 3.15 SUBMITTALS

- A. Product Data for lumber, metal-plate connectors, metal framing connectors, bolts, and fasteners.
- B. Shop Drawings detailing location, pitch, span, camber, configuration, and spacing for each type of truss required; species, sizes, and stress grades of lumber to be used; splice details; type, size, material, finish, design values, and orientation and location of metal connector plates; and bearing details. Minimum size of erection drawing shall be 24"X36".
  - 1. Include structural analysis data and design calculations signed and sealed by the qualified professional engineer responsible for their preparation.
  - 2. Include truss Shop Drawings signed and sealed by the qualified professional engineer responsible for their preparation.
- C. Product certificates signed by officer of truss fabricating firm certifying that metal-plate-connected wood trusses supplied for Project comply with specified requirements and Shop Drawings.
- D. Qualification data for firms and persons specified in "Quality Assurance" Article to demonstrate their capabilities and experience. Include lists of completed projects with project names and addresses, names and addresses of architects and owners, and other information specified.
- E. Material certificates for dimension lumber specified to comply with minimum allowable unit stresses. Indicate species and grade selected for each use and design values approved by the American Lumber Standards Committee (ALSC) Board of Review.
- F. Research or evaluation reports of the model code organization acceptable to authorities having jurisdiction that evidence the following products' compliance with building code in effect for Project.
  - 1. Metal-plate connectors.
  - 2. Metal framing connectors.

### 3.16 QUALITY ASSURANCE

- A. Installer Qualifications: Engage an experienced Installer who has completed wood truss installation similar in material, design, and extent to that indicated for this Project and with a record of successful in-service performance.
- B. Fabricator's Qualifications: Engage a firm that complies with the following requirements for quality control and is experienced in fabricating metal-plate-connected wood trusses similar to those indicated for this Project and with a record of successful in-service performance:
  - 1. Fabricator participates in a recognized quality-assurance program that involves inspection by SPIB; Timber Products Inspection, Inc.; Truss Plate Institute (TPI); or other independent inspecting and testing agency acceptable to Architect and authorities having jurisdiction.
- C. Comply with applicable requirements and recommendations of the following publications:
  - 1. ANSI/TPI 1, "National Design Standard for Metal-Plate-Connected Wood Truss Construction."
  - 2. TPI HIB "Commentary and Recommendations for Handling Installing & Bracing Metal Plate Connected Wood Trusses."
  - 3. TPI DSB "Recommended Design Specification for Temporary Bracing of Metal Plate Connected Wood Trusses."
- D. Metal-Plate Connector Manufacturer's Qualifications: A manufacturer that is a member of TPI and that complies with TPI quality-control procedures for manufacture of connector plates published in ANSI/TPI 1.
- E. Single-Source Responsibility for Connector Plates: Provide metal connector plates from one source and by a single manufacturer.
- F. Wood Structural Design Standard: Comply with applicable requirements of AFPA's "National Design Specification for Wood Construction" and its "Supplement."
- G. Single-Source Engineering Responsibility: Provide trusses engineered by metal-plate connector manufacturer to support superimposed dead and live loads indicated, with design approved and certified by a qualified professional engineer.
- H. Professional Engineer Qualifications: A professional structural engineer licensed in the State of New Hampshire who is experienced in providing engineering services of the kind indicated that have resulted in installing metal-plate-connected wood trusses similar to those indicated for this Project and with a record of successful in-service performance.

### 3.17 DELIVERY, STORAGE, AND HANDLING

- A. Handle and store trusses with care and comply with manufacturer's written instructions and TPI recommendations to avoid damage and lateral bending.
- B. Inspect trusses showing discoloration, corrosion, or other evidence of deterioration. Discard and replace trusses that are damaged or defective.

### 3.18 SEQUENCING AND SCHEDULING

- A. Time delivery and erection of trusses to avoid extended on-site storage and to avoid delaying progress of other trades whose work must follow erection of trusses.

## PART 4 - PRODUCTS

### 4.01 MANUFACTURERS

- A. Manufacturers: Subject to compliance with requirements, provide products by one of the following:
  - 1. Metal Connector Plates:
    - a. Alpine Engineered Products, Inc.
    - b. Mitek Industries, Inc.
  - 2. Metal Framing Anchors:
    - a. Simpson Strong-Tie Company, Inc.
    - b. United Steel Products Co.

### 4.02 DIMENSION LUMBER

- A. Lumber Standards: Comply with DOC PS 20, "American Softwood Lumber Standard," and with applicable grading rules of inspection agencies certified by ALSC's Board of Review.
- B. Inspection Agencies: Inspection agencies, and the abbreviations used to reference them, include the following:
  - 1. NELMA - Northeastern Lumber Manufacturers Association.
  - 2. NLGA - National Lumber Grades Authority (Canadian).
  - 3. SPIB - Southern Pine Inspection Bureau.
- C. Grade Stamps: Provide lumber with each piece factory marked with grade stamp of inspection agency evidencing compliance with grading rule requirements and identifying grading agency, grade, species, moisture content at time of surfacing, and mill.
- D. Provide dressed lumber, S4S, manufactured to actual sizes required by DOC PS 20 for moisture content specified, to comply with requirements indicated below:
  - 1. Provide dry lumber with 19 percent maximum moisture content at time of dressing.
- E. Grade and Species: Provide dimension lumber of any species for truss chord and web members, graded visually or mechanically, and capable of supporting required loads without exceeding allowable design values according to AFPA's "National Design Specification for Wood Construction" and its "Supplement."
- F. Member Size: Minimum member size used in any truss shall be 2X4.

#### 4.03 METAL CONNECTOR PLATES

- A. General: Fabricate connector plates from metal complying with requirements indicated below.
- B. Hot-Dip Galvanized Steel Sheet: Structural-quality steel sheet, zinc coated by hot-dip process complying with **ASTM A 653, G60 (ASTM A 653M, Z180)** coating designation; Grade 33 and not less than **0.0359 inch (0.91 mm)** thick.
- C. Electrolytic Zinc-Coated Steel Sheet: **ASTM A 591 (ASTM A 591M)**, structural-(physical) quality steel sheet, zinc coated by electro deposition; **33,000-psi (230-MPa)** minimum yield strength, coating class C, and not less than **0.0474 inch (1.20 mm)** thick.

#### 4.04 FASTENERS

- A. General: Provide fasteners of size and type indicated that comply with requirements specified below for material and manufacture.
- B. Nails, Wire, Brads, and Staples: FS FF-N-105.
- C. Wood Screws: ASME B18.6.1.
- D. Lag Bolts and Screws: **ASME B18.2.1 (ASME B18.2.3.8M)**.
- E. Bolts: Steel bolts complying with **ASTM A 307, Grade A (ASTM F 568, Property Class 4.6)**; with **ASTM A 563 (ASTM A 563M)** hex nuts and, where indicated, flat washers.

#### 4.05 METAL FRAMING ANCHORS

- A. General: Provide metal framing anchors of structural capacity, type, size, metal, and finish indicated that comply with requirements specified, including the following:
  - 1. Research or Evaluation Reports: Provide products for which model code research or evaluation reports exist that are acceptable to authorities having jurisdiction and that evidence compliance of metal framing anchors for application indicated with building code in effect for this Project.
  - 2. Allowable Design Loads: Provide products with allowable design loads, as published by manufacturer, that meet or exceed those indicated. Manufacturer's published values shall be determined from empirical data or by rational engineering analysis, and demonstrated by comprehensive testing performed by a qualified independent testing agency.
- B. Galvanized Steel Sheet: Hot-dip, zinc-coated steel sheet complying with **ASTM A 653, G185** coating designation; structural, commercial, or lock-forming quality, as standard with manufacturer for type of anchor indicated.

#### 4.06 FABRICATION

- A. Cut truss members to accurate lengths, angles, and sizes to produce close-fitting joints.

- B. Fabricate metal connector plates to size, configuration, thickness, and anchorage details required to withstand design loadings for types of joint designs indicated.
- C. Assemble truss members in design configuration indicated using jigs or other means to ensure uniformity and accuracy of assembly with joints closely fitted to comply with tolerances of ANSI/TPI 1. Position members to produce design camber indicated.
  - 1. Fabricate wood trusses within manufacturing tolerances of ANSI/TPI 1.
- D. Connect truss members by metal connector plates located and securely embedded simultaneously into both sides of wood members by air or hydraulic press.
- E. Clearly mark locations where truss webs require lateral bracing using red tags of similar.

## PART 5 - EXECUTION

### 5.01 INSTALLATION

- A. Do not install wood trusses until supporting construction is in place and is braced and secured.
- B. Before installing, splice trusses delivered to Project site in more than one piece.
- C. Hoist trusses in place by lifting equipment suited to sizes and types of trusses required, exercising care not to damage truss members or joints by out-of-plane bending or other causes.
- D. Install and brace trusses according to recommendations of TPI and as indicated. Proper installation of erection bracing is solely the responsibility of the contractor and is not detailed on structural drawings.
- E. Install trusses plumb, square, and true to line and securely fasten to supporting construction.
- F. Space, adjust, and align trusses in location before permanently fastening.
- G. Anchor trusses securely at all bearing points using metal framing anchors. Install fasteners through each fastener hole in metal framing anchor according to manufacturer's fastening schedules and written instructions.
- H. Securely connect each truss ply required for forming built-up girder trusses.
  - 1. Anchor trusses to girder trusses as indicated.
- I. Install and fasten permanent bracing during truss erection and before construction loads are applied. Anchor ends of permanent bracing where terminating at walls or beams.
  - 1. Install and fasten strongback bracing vertically against vertical web of parallel-chord floor trusses at centers indicated.
- J. Install wood trusses within installation tolerances of ANSI/TPI 1.
- K. Do not cut or remove truss members.



- L. Return wood trusses that are damaged or do not meet requirements to fabricator and replace with trusses that do meet requirements.
  - 1. Do not alter trusses in the field.

#### 5.02 REPAIRS AND PROTECTION

- A. Repair damaged galvanized coatings on exposed surfaces with galvanized repair paint according to ASTM A 780 and manufacturer's written instructions.

---

### **DIVISION 7- THERMAL AND MOISTURE PROTECTION**

- A. Provide 6 mil polyethylene sheet vapor barrier continuously, over compacted fill, under new concrete floor slabs on grade. Lap all joints 6" min. And tape. Protect against puncture.
  - B. Provide a complete weather tight and secure roofing system as noted on the drawings with all required accessories, and installed in accordance with the manufacturer's recommendations. Notify the architects of any conditions which might compromise the integrity of the roofing work. Provide 36" wide self-adhering membrane underlayment at all eaves, valleys, wall to roof intersections, etc. As recommended by the manufacturer. Color of shingles to be selected by the architect.
  - C. All required step, base, and cap flashings, copings, etc. Shall be fabricated from 0.32" aluminum or 16 oz. C.R.copper to shapes as recommended by the SMACNA manual. Provide at roof and frame wall conditions.
  - D. Provide attic ventilation per code.
  - E. Provide all caulking and sealants necessary to fill all exterior and interior joints between dissimilar materials. Install backer rod material where required.
-

### **DIVISION 8- DOORS AND WINDOWS**

- A. Provide all new doors and related hardware of types and sizes as indicated on the drawings. Apply sealer to all surfaces, edges, mortises, etc. Of all wood doors.
  - B. Hardware design shall be as approved by the owner and the architect. Provide all hardware necessary for the proper operation of all work on this project. Refer to the drawings for hardware functions. Confirm door keying and security with the owner.
  - C. Provide complete weather-stripping for all new exterior doors of neoprene bulb/ aluminum strip at head and jambs and vinyl sweep/ aluminum strip at bottom.
  - D. Provide all new windows and glass types as indicated on the drawings, complete with all standard hardware and noted options. Confirm tempered glass locations before ordering. Install all doors and windows in accordance with NWWDA guidelines, manufacturer's recommendations, and as detailed. Provide metal drip caps at heads and fabric flashing at jambs and sills of all exterior door and window frames.
- 

### **DIVISION 9- FINISHES**

- A. Provide standard type 5/8" type 'x' gypsum wallboard on all interior walls and ceilings, except for wet areas which shall be moisture resistant gypsum wallboard. Include in the work all necessary accessories and joint finishing systems to provide a flat, smooth surface, free of defects and complying with the applicable requirements of ga-216-85 "application and finishing of gypsum board" by the gypsum association.
  - B. Prepare surfaces to be painted or otherwise finished, by filling voids, sanding and cleaning. Apply finishes, as indicated, to interior and exterior surfaces using only nationally known or owner approved products. Store in a safe, secure manner. All painted surfaces shall receive at least two finish coats over a prime coat. Color and finish types shall be selected by owner and the architect.
  - C. Sheet vinyl and/or vinyl tile flooring shall be as selected by the owner and architect. The contractor shall provide underlayments and furnish and install all materials and accessories necessary to complete the work in accordance with the resilient flooring manufacturer's recommendations.
  - D. Ceramic tile shall be as selected by the owner and architect. The contractor shall furnish and install all the work in accordance with the Tile Council of America, Inc. Recommendations for each application indicated. Provide cementitious backer board for tile work at all walls in wet locations.
  - E. Protect all new and existing finished surfaces against damage while work on this project is progressing or uncompleted.
- 

### **DIVISION 10- SPECIALTIES**

All toilet accessories, medicine cabinets, mirrors, and any other equipment as indicated on the drawings shall be furnished and installed by the contractor following owner and architect approval.

---

### **DIVISION 11- EQUIPMENT**

Counters and cabinets are to be manufactured units of AWI quality as selected by the owner and architect. All casework shall be furnished and installed by the contractor, complete with all standard hardware.

---

**DIVISION 22- PLUMBING**

Perform the work included in this scope in accordance with 2009 international plumbing code (IPC), international energy conservation code (IECC), international fuel gas code (IFGC), New Hampshire plumbing code and local codes and regulations.

Provide premium efficiency equipment in accordance with IECC.

Coordinate installation of equipment with existing architectural, structural, mechanical and electrical systems.

Provide submittals of water heater, piping, pipe insulations and plumbing fixtures for approval.

Install piping, equipment and accessories above ceilings and behind walls unless specifically directed by the architect.

Provide sleeves for piping passing through walls, floors and ceilings. Inner diameter of sleeves shall be a minimum of ½" larger than the outside diameter of pipes. Provide sleeves sized to accommodate insulated pipes.

Provide chrome-plated escutcheons at exposed pipe penetrations through walls.

Drain pan: type 304 stainless steel, sheet, 16 gauge, welded seams. Airstream surfaces ASHRAE 621-2007 compliance.

Provide equipment and fixtures indicated on schedules or equipment with construction and performance equaling or exceeding equipment scheduled.

Install systems as indicated on the drawings. Do not deviate from the arrangements shown on the drawings without prior approval of the project manager.

Coordinate work to be performed in each area with the project manager prior to commencing work.

Coordinate cutting and/or drilling through structural members with the project manager prior to commencing work.

Remove debris and construction waste from work areas on a continual basis. Do not allow debris and construction waste to accumulate on site. Remove and transport debris in a manner which will prevent spillage on adjacent surfaces and areas. Remove debris from elevated portions of the building by chute, hoist or other device that will convey debris to the ground level in a controlled descent.

Do not burn removed materials.

Transport removed materials off site and legally dispose of them.

Storage or sale of removed items or materials on-site is not permitted.

**WATER SUPPLY PIPE AND FITTINGS:**

Above ground domestic water supply piping: drawn-temper copper tubing, ASTM-b88, type l, wrought-copper fittings, ASME b16.22.

Below ground domestic water supply piping: annealed temper copper tubing ASTM b88, type k.

Drain piping: drawn-temper copper tubing, ASTM b306, type DWV.

**JOINING MATERIALS:**

Solder filler metals. ASTM b32, lead-free alloys, washable flux.

Brazing metal: copper-phosphorus brazing metal, AWS a5.8

**JOINING METHODS:**

Soldered joints: apply ASTM b813, water-flushable flux, unless otherwise indicated, to the tube end.

Construct joints using lead-free solder according to ASTM b238 or "copper tube handbook" published by the copper development association (CDA).

Brazing: construct joints according to "brazing handbook" published by the American Welding Society (AWS), using copper-phosphorus brazing metal complying with AWS a5.8.

**SANITARY WASTE AND VENT PIPING:**

Below ground: hub and spigot cast iron piping, ASTM a74, with compression gaskets.

Above ground: hub and spigot cast iron piping, ASTM a74, with compression gaskets or hubless, ASTM

a888, with no-hub couplings and three-band clamps.

#### GAS AND PIPE FITTINGS:

Black steel pipe, ASTM a53 schedule 40, threaded ends with ASME b16.3 class 150 malleable threaded fittings.

#### VALVES:

Shutoff valves: ball valves, mss sp-110 , full port, two part bronze, threaded ends.

Check valves: mss sp-80, bronze, solder ends.

Vacuum relief valves: ansi z21.22/csa 4.4, brass

Water heater drain valves: asme bpvc sec iv, bronze

Temperature and pressure relief valve: ANSI z21.22/csa 4.4, brass, hose thread outlet

Thermostatic mixing valve: bronze duplex high/low mixing valve assembly equipped with inlet and outlet checkstops, locking adjustment handle, outlet ball valve shutoffs, thermometer on outlet, check valves, unions and sediment strainers on inlets, 100 to 150 degree f minimum adjustment range, +/-2 degrees f accuracy.

Automatic gas shutoff valve will be furnished by the kitchen consultant. Gas installation will be by the plumbing contractor.

#### PIPE INSULATION:

Domestic cold water: closed-cell flexible elastomeric insulation, ASTM c534 type 1, self-adhesive butt joint and self-adhesive lap, thermal conductivity: 0.245 water vapor transmission, 0.03 perms, uv resistant, astmg7 and g90, flame spread rating of 50 or less per ASME e84. 1/2" thickness.

Domestic hot water: pre-formed fiberglass insulation, bonded with thermosetting resin. Comply with astm c547, type i, grade a, with factory applied all service jacked and self-sealing lap, 1: insulation thickness.

#### PIPE HANGERS AND SUPPORTS:

Copper clad carbon steel pipe hangers and supports, mss sp-58, type a bands or clevis hangers, galvanized, continuous thread 5/16" diameter rod, nuts and washer, galvanized pipe saddles, 1/2" long. Provide 25 psi polysocyanurate thermal hanger shield inserts to support insulated pipe without compression. Hanger spacing in accordance with 2009 ipc.

#### PIPING IDENTIFICATION:

Pre-printed, pre-tensioned semi-rigid plastic pipe labels, color-coded with lettering indicating servicem and showing flow direction. 1 1/2" minimum lettering size. For domestic cold water piping provide white lettering on green background. For domestic hot water piping provide white lettering on yellow background. For natural gas piping provide black lettering on yellow background.

#### GAS FIRED TANK-TYPE WATER HEATER:

ANSI z21.10.3/CSSA 4.3 cement or glass lined steel tank, 1" mineral fiber insulation between tank and jacket, gas control valve, 90-160 degree f adjustment range. Provide temperature and pressure relief valve, drain valve, vacuum relief valve and 4" diameter gas vent and sidewall cap.

Plumbing fixtures: water conservation type in conformance with 2009 IBC. Fixtures for use by physically handicapped individuals shall be in accordance with ICC/ANSI a117.1. Plumbing fixtures shall be white vitreous china unless otherwise indicated. Provide necessary hardware for plumbing fixtures, including but not limited to wall bracket supports for lavatories and urinals. (stainless steel bolts, nuts and fittings). Gaskets, decorative caps and covers, provide ASSE 1037 battery powered sensor operated flush valves for water closets and urinals. Floor drains shall have nickel bronze finish. Plumbing fixtures indicated as basis of design on plumbing rough-in schedule satisfy material requirements.

---

## **DIVISION 23- MECHANICAL**

### **VENTILATING SPECIFICATIONS**

Perform the work included in this project scope in accordance with 2009 international mechanical code (MWC), international energy conservation code (IECC), Portsmouth amendments, local codes and regulations.

Coordinate installation of equipment with existing architectural, structural, plumbing and electrical systems.

Provide submittals of fans, curbs, dampers, roof vents, ductwork, insulation, supports and hangers for approval.

Install ductwork, equipment and accessories after coordination has been reviewed and approved by the architect.

Coordinate all duct runs and penetration locations with other trades to ensure proper clearances are made to electrical devices and equipment. Provide required clearances for maintenance.

Coordinate cutting and/or drilling through structural members with the project manager prior to commencing work.

Remove debris and construction waste from work areas on a continual basis. Do not allow debris and construction waste to accumulate on site. Remove and transport debris in a manner which will prevent spillage on adjacent surfaces and areas. Remove debris from elevated portions of the building by chute, hoist or other device that will convey debris to grade level in a controlled descent.

Do not burn removed materials.

Transport removed materials off site and legally dispose of them.

Storage or sale of removed items or materials on-site is not permitted.

### **KITCHEN EXHAUST SYSTEM:**

The kitchen supplier will be supplying the hood, ductwork and exhaust fan for installation by the mechanical contractor. These plans show proposed duct details and sizes for pricing and permitting. Once the sizes and equipment have been confirmed revised plans and details will be submitted.

### **DISHWASHER EXHAUST:**

Install aluminum dishwasher exhaust from the furnished dishwasher to the furnished exhaust fan. Install vertically. If offsets need to be made, slope duct a minimum of ¼" per foot back in the direction of the dishwasher hood.

### **BATHROOM EXHAUST:**

Provide bathroom exhaust as indicated on the plans. The ceilings are flat sheetrock. Run ductwork concealed behind the ceilings and walls to maximum extent possible.

### **HOT WATER HEATER COMBUSTION AIR:**

Install a roof mounted gravity ventilator to provide combustion air as indicated on the plans. Provide the ventilator with a ¼" high curb with insect screen. The 12x12 combustion air duct is to drop down to the ceiling level with a framed ¼" x ¼" expanded aluminum mesh.

This communication with the outdoors can also act as transfer air for a single future type 2 clothes dryer.

---

## **DIVISION 26- ELECTRICAL**

### **Part 1 – General**

1. General provisions: drawings are diagrammatic and indicate general arrangement of work in contract. Refer to all drawings associated with this project (each trade) for exact location of all equipment and required mounting heights.

2. Scope: perform work and provide new material and equipment as shown on drawings and as specified in this section of the specifications. Provide all components and materials, whether specifically shown or not, that are necessary to make the systems complete and fully operational. Work shall include, but not be limited to: 1) removal of existing electrical system at the concession building, 2) installation of new power distribution, lighting and fire alarm system as illustrated on these drawings, 3) all testing and certifications necessary for compliance and any required remedial actions and retesting due to failure.
3. Site visit: visit and carefully examine site to identify existing conditions that may affect work of this section before submitting bid. No extra payment will be allowed for additional work caused by unfamiliarity with site conditions that are visible or readily discerned.
4. Related work: the following work is not included in this section and will be provided under other sections: 1) temporary lighting and power for use during construction and testing unless specifically noted in other specification sections, 2) painting.
5. Codes, standards, authorities and permits: all work shall be performed in accordance with the latest editions of the state building code, the state electrical code, NFPA, ANSI/NECA installation standards and other applicable codes, regulations and laws of local, state and federal government, other authorities having jurisdiction and applicable base building standards and specifications. Codes, laws and ordinances provide a basis for the minimum installation criteria. These drawings and specifications illustrate the scope required for this project, which may exceed minimum code, law and standards criteria. Give notices, file plans, obtain permits and licenses, pay back charges and obtain necessary approvals from utility companies and authorities having jurisdiction as required for the execution of all work associated with this project.
6. Interpretation of documents: advise the engineer in writing (RFI) prior to proceeding with procurement or installation that the design intent is unclear or that construction documents do not coincide with manufacturer's recommendations. All costs for rework necessary to resolve discrepancies shall be the responsibility of the contractor.
7. Request for information: RFI issued to resolve a conflict or discrepancy shall be provided with the preferred solution via written description or sketch.
8. Submittals: provide specified materials and equipment unless "equal" or "approved equal" is explicitly indicated on the drawings. Deviations to specified materials shall be at the sole risk of the contractor, who shall be responsible for all associated changes to this and other trades. Submittals shall indicate review and approval by the responsible contractor. Submit for review (6) sets of manufacturer's product data for devices (receptacles and switches) and plates; panel boards, circuit breakers; disconnect switches. Allow engineer a minimum of 10 working days for processing and review of each submission.
9. Operation and maintenance data: submit (3) sets of operating and maintenance manuals including system description, wiring diagrams, written warranty, recommended spare parts and routine maintenance requirements with recommended intervals for all supplied equipment.
10. Record drawings: cad record drawing files shall be submitted at the completion of the project showing the "as-built" condition including work installed and all modifications or additions to original design. Obtain the AutoCAD files for preparation of as-built drawings from the architect. The architect and engineer are not granting any ownership or property interest in the cad drawings by the delivery of the cad files. The rights to use the cad files and drawings are limited to use for the sole purpose of assisting in the performance of contractual obligations with respect to this project. Any reuse and/or other use will be at the contractor's sole risk and without liability to the architect and engineer.
11. Warranties: warranty installation in writing for one year from date of owner's acceptance of certificate of substantial completion. Repair, replace or provide temporary accommodations for

- defective materials, equipment, workmanship and installation that develop within 24 hours of notification. Warranty shall include a contact person (name and 24 hour telephone number) for service requests. Correct damage caused while making necessary repairs and replacements under warranty period at no additional cost.
12. Coordination: confer with all other trades relative to location of all apparatus and equipment to be installed and select locations so as not to conflict with or hinder progress of work of other sections. Work installed that creates interference or restricts access required by code or to conduct maintenance and/or adjustments shall be modified at no additional cost to the owner.
  13. Supports: include all structural steel supports, hanger brackets, etc., required for the execution of the work of this section. Hangers shall be prefinished channel and threaded rod used with approved clamps, hardware, etc. Channel installed in exterior locations shall be galvanized steel with stainless steel hardware.
  14. Cutting and patching: include all coring, cutting, patching and fireproofing necessary for the execution of the work of this section. Structural elements shall not be cut without written approval of the architect. Provide fire stopping to maintain the fire rating of the fire resistance-rated assembly. All penetrations and associated fire stopping shall be installed in accordance with the fire stopping manufacturer's listed installation details and be listed by UL or FM.
  15. Hoisting, scaffolding and planking: include the furnishing, set-up and maintenance of all hoisting machinery, cranes, scaffolds, staging and planking as required for the execution of work for this section.
  16. Safety precautions: life safety and accident prevention shall be a primary consideration. Comply with all of the safety requirements of the owner and OSHA throughout the entire construction period of the project. Furnish, place and maintain proper guards and any other necessary construction required to secure safety of life and property.
  17. Accessibility: all work provided under this section of the specification shall be so that parts requiring periodic inspection, maintenance and repair are readily accessible. Work of this trade shall not infringe upon clearances required by equipment of other trades,
  18. Protection of work and property: this contractor shall be responsible for the care and protection of all work included under this section until the completion and final acceptance of this project. Protect all equipment and materials from damage from all causes including, but not limited to, fire vandalism and theft. All materials and equipment damaged or stolen shall be repaired or replaced with equal material or equipment at no additional cost to the owner. Protect all equipment, outlets and openings, and roof penetrations with temporary plugs, caps and covers. Protect work and materials of other trades from damage that might be caused by work or workmen under this section and make good damage thus caused. Damaged materials are to be removed from the site; no site storage of damaged materials will be allowed. Any damage to existing systems and equipment caused by this contractor during installation shall be repaired and/or replaced at this contractor's expense to the complete satisfaction of the building owner.
  19. Not Used
  20. Project closeout: a certificate of completion shall be issued by the contractor indicating that the installation is in conformance with the construction documents and all applicable local, state and federal statutes and codes. All submittals, as-builts, o&m manuals, and balancing reports are to be provided, for engineer's review, prior to request for completion certificates. In addition, and also prior to request for completion certificates, all punch list items must be completed to the satisfaction of the engineer. The contractor must verify that all sequences of operations and

controls have been incorporated and all systems and equipment are working per the specified sequences of operations.

## Part 2 – Products

1. Identification: nameplates shall indicate equipment tag, voltage characteristics and source of power. Refer to nameplate detail for additional information.
2. Raceways and conduit: rigid galvanized steel conduit (RGS) shall be utilized with threaded fittings only. Electrical metallic tubing (EMT) shall be utilized with compression couplings. Provide conduit expansion fittings with external bonding jumpers equal to oz gedney type ex for rgs and type tx for emt when crossing expansion joints. Ul listed liquid tight flexible metal conduit (LFMC) and flexible metal conduit (FMC) shall be used for final connections to equipment where flexibility or vibration isolation are required. Lfmc shall be UV resistant when installed in an exterior location.
3. Wire and cable: all conductors shall be type thhn/thwn or xhhw, copper, rated 75°/90°c, 600 volt insulation unless otherwise noted. Minimum size conductor shall be #12 awg copper. Conductors #10 awg and larger shall be stranded; #12 awg and smaller shall be solid. Each branch circuit and feeder shall be provided with an insulated grounding conductor sized in accordance with NEC table 250.122. Conductor color coding shall be in accordance with the details on these drawings. Color coding shall be consistent throughout including conductors installed in raceways and in all cable assemblies (mc and/or ac). Flexible metal clad (mc) cable shall be UL listed with insulated thhn phase and ground conductors within a galvanized steel or aluminum interlocking armor.
4. Wiring devices and plates: all devices shall be specification grade with nylon plate, color as specified by the architect or to match existing. All devices shall have a green grounding terminal on the yoke. Receptacles shall be UL federal specification wc-596 extra heavy duty 20a 125v equal to cooper 5362. Gfci receptacles shall be commercial specification grade 20a 125v equal to cooper gf20. Switches shall be industrial-institutional heavy duty specification grade 20a 120/277v equal to cooper 2200 series.
5. Safety disconnect switches: disconnect switches shall be three-pole heavy duty type rated for 600 volt in nema 1 (interior dry applications) and NEMA 3r (exterior applications) enclosures unless noted otherwise on the drawings. All switches shall be horsepower rated and suitable for service entrance use where indicated on the drawings. Provide with solid neutral where four wire circuits are illustrated. Manual motor starters shall have quick make, quick break toggle mechanisms with allowance for up to 10% field adjustment to nominal overload heater values. Manual motor starters shall be single phase and may be used for applications up to 1 hp at 277 volt. Acceptable manufacturers shall be Square D, GE, Siemens or Eaton Cutler-Hammer.
6. Panelboards shall be circuit breaker type with thermal magnetic bolt-on molded case circuit breakers and copper busses. Minimum interrupting capacity shall be 10,000 amps symmetrical at 208 volt and 14,000 aic at 480 volt. Refer to panel schedules for exact aic ratings of equipment. Panelboard covers shall be door-in-door design up to and including 400a. Acceptable manufacturers shall be Square D, GE, Siemens or Eaton Cutler-Hammer.
7. Main distribution panelboard, square d i-line type hcr-u with 1200 amp, 3-pole main circuit breaker, or equal, shall be circuit breaker type with thermal magnetic bolt-on molded case circuit breakers and copper busses. Minimum interrupting capacity shall be 65,000 amps symmetrical and shall be rated nema 3r for exterior applications. Refer to panel schedules for exact aic ratings of equipment.
8. Fire alarm system: provide labor, materials, and equipment required for complete installation of fire alarm system as shown on floor plans of drawing.
  - A. Fire alarm control panel shall have battery back-up and shall be manufactured by Honeywell



fire lite alarms or equal, with 4-zones, class b initiating device circuits and compatible with two- and four- wire initiating devices.

B. Smoke detectors shall be photoelectric type sd-355, manufactured by Honeywell fire lite alarms or equal.

C. Horn/strobe unit shall be type p2r, manufactured by system sensor or equal, with standard candela settings: 15, 15/75, 30, 75, 95, 110 & 115 candela settings.

D. Pull station shall be manufactured by GE Interlogix or equal, with manual dual action operation, cat 30 key reset and non-coded SPST.

E. Heat detectors shall be fixed temperature/rate-of-rise 135° f, model 5601, manufactured by Honeywell fire lite alarms or equal.

### Part 3 – Execution

1. General: all interruptions and shutdowns of existing electrical systems and services shall be as short as possible and at a time and duration approved by the owner and engineer. The contractor shall include all premium time associated with the system and service interruptions and shutdowns.
2. Identification: furnish and install nameplates on all electrical equipment including panels, junction boxes, disconnect switches, transformers and starters.
3. Raceways and conduit: refer to power, lighting and fire alarm drawings for allowable wiring methods. EMT may be used with set screw fittings in concealed and exposed locations where not exposed to physical damage or moisture. Use rigid galvanized steel with threaded fittings where emt prohibited. All raceways, which pass through building expansion joints, shall be equipped with expansion fittings. All conduits shall be supported in an approved manner to the building structure. Support from conduits, ductwork, piping, etc. will not be permitted. Raceways shall be run concealed unless noted otherwise, perpendicular and/or parallel to the building structure. Neca standards shall define minimum quality level for installation where applicable.
4. Wire and cable: branch circuit wiring is not illustrated on the drawings and is indicated by circuit numbers next to fixtures, equipment and devices. Provide complete wiring system to meet illustrated intent. Conduit homeruns shown on the drawings with more than 3 current carrying conductors are shown diagrammatically. The installation of more than 3 current carrying conductors in a common raceway shall require the derating of all associated conductors. All circuits shall contain a full size, insulated ground conductor.
5. Wiring devices and plates: all devices other than 20a 120v shall be clearly labeled with permanently applied nameplates (or engraved faceplates) detailing the voltage characteristics and circuit number.
6. Safety disconnect switches: fuses shall be class rk-1 sized per drawing and nameplate requirements. Install rejection clips to prohibit installation of other than current limiting fuses.
7. Panelboards: the contractor shall balance panelboard loads to within 10% phase to phase. Provide new and or updated typewritten directories of branch circuits in all panelboards, new and existing, which are modified under this contract. Indicate circuit changes in as-built record drawings.
8. Equipment testing and cleaning:  
Clean the interior and exterior of all equipment at project completion of all construction debris and residue. Damaged surfaces shall be repaired and finishes touched up paint to match the manufacturer's finish. Extensively damaged enclosures shall be replaced.  
Test the insulation resistance between each phase and ground of all feeders illustrated on the one line diagram. Provide a test report indicating the results. Replace all conductors that fail to

comply with NETA testing standards.

Verify voltage at the associated panel board under load and adjust tap settings as required to deliver nominal voltage during normal and lightly loaded conditions.

**DOOR SCHEDULE**

<b>NO.</b>	<b>ROOM NAME</b>	<b>DOOR</b>	<b>MATERIAL</b>	<b>SIZE</b>	<b>FRAME</b>	<b>DETAILS</b>	<b>HRDWR</b>	<b>NOTES</b>
1	STAIR 108	1,	STL	3'-0" x 7'-0"	1	HM	1,3,7	-
2	WOMEN'S ROOM 104	4,	WD	3'-9" x 7'-0"	-		2,8,9	-
3	WOMEN'S ROOM 104	1,	STL	3'-0" x 7'-0"	1	HM	1,3,7	-
4	MEN'S ROOM 106	1,	STL	3'-0" x 7'-0"	1	HM	1,3,7	-
5	MEN'S ROOM 108	4,	WD	3'-9" x 7'-0"	-	-	2,8,9	-
6	KITCHEN 103	1,	STL	3'-0" x 7'-0"	-	HM	1,3,7	-
7	KITCHEN 103	2,	STL	3'-0" x 4'-4"	-	HM	-	COUNTER DR
8	KITCHEN 103	2,	STL	3'-0" x 4'-4"	-	HM	-	COUNTER DR
9	KITCHEN 103	2,	STL	3'-0" x 4'-4"	-	HM	-	COUNTER DR
10	KITCHEN 103	2,	STL	3'-0" x 4'-4"	-	HM	-	COUNTER DR
11	SODA 107	3,	STL	3'-0" x 7'-0"	-	HM	-	OVRHD DR
12	STAIR 108	1,	HM	3'-0" x 6'-8"	1	HM	1,4,7	-
13	TOILET 102	1,	HM	2'-6" x 6'-8"	1	HM	1,5	-
14	JANITOR 105	1,	HM	2'-6" x 6'-8"	1	HM	1,6	-
15	STORAGE 201	1,	HM	3'-0" x 6'-8"	1	HM	1,4,7	-
16	UNISEX BATH	1,	STL	3'-0" x 6'-8"	-	HM	1,3,7	-

**HARDWARE SCHEDULE**

<b>NO.</b>	<b>DESCRIPTION</b>	<b>MANUFACTURER</b>	<b>MODEL</b>	<b>DESCRIPTION</b>
1	HINGE SET	STANLEY	F179 US26D	3 HINGES, 4-1/2" x 4-1/2", BRUSHED CHROME BALL BEARING
2	HINGE SET - LATTICE GATE	STANLEY	F179 US26D	2 HINGES, 4-1/2" x 4-1/2", BRUSHED CHROME BALL BEARING
3	PUSHPLATE/PULLBAR/ DEADBOLT LOCK	ROCKWOOD/ SCHLAGE		ROCKWOOD PUSH PLATE 70C,PULL PLATE 111X70C STAINLESS STEEL, DEADBOLT LOCK: SCHLAGE B500 SERIES, KEY BOTH SIDES, SATIN CHROME
4	DOOR LEVER /LOCK SET	SCHLAGE	S10D	S-SERIES, STYLE "NEPTUNE", PASSAGE LATCH, FINISH 626 SATIN CHROMIUM PLATED
5	DOOR LEVER /LOCK SET	SCHLAGE	S40D	S-SERIES, STYLE "NEPTUNE", BEDROOM/BATHROOM PRIVACY LOCK, FINISH 626 SATIN CHROMIUM PLATED
6	DOOR LEVER /LOCK SET	SCHLAGE	L9070	L-SERIES, HEAVY DUTY, CLOSET LOCK, FINISH 626 SATIN CHROMIUM PLATED
7	DOOR CLOSER	LCN	P1371	DOOR CLOSER W/ ALUMINUM FINISH
8	PAD LOCK	-	-	-
9	HOOK AND EYE FOR GATE	-	-	-

**BATHROOM FIXTURE AND ACCESSORY SCHEDULE**

<b>ITEM</b>	<b>MODEL#</b>	<b>DESCRIPTION</b>	<b>NOTES</b>
1	2854.128	AMERICAN STANDARD MADERA ADA 1.28 GPF AND MANUAL FLUSH VALVE, FLOOR MOUNTED TOILET	-
2	6590.125	AMERICAN STANDARD WASHBROOK 0.125 GPF URINAL WITH MANUAL FV	-
3	4869.004	AMERICAN STANDARD REGALYN ENAMELED CAST IRON WALL HUNG SINK	-
4	5502.170	AMERICAN STANDARD MONTERREY CENTERSET LAVATORY FAUCET W/GRID DRAIN	-
5	-	GLOBAL FLOOR ANCHORED/OVERHEAD BRACED STAINLESS STEEL TOILET PARTITIONS	#4 SATIN FINISH
6	B-5806x36	36" HORIZONTAL BOBRICK SERIES CONCEALED MOUNTING W/SNAP FLANGE GRAB BAR	PEENED NON-SLIP GRIPPING SURFACE
7	B-5806x42	42" HORIZONTAL BOBRICK SERIES CONCEALED MOUNTING W/SNAP FLANGE GRAB BAR	PEENED NON-SLIP GRIPPING SURFACE
8	B-5806x18	18" VERTICAL BOBRICK SERIES CONCEALED MOUNTING W/SNAP FLANGE GRAB BAR	PEENED NON-SLIP GRIPPING SURFACE
9	B-166 2436	24"x36" BOBRICK CLASSIC SERIES CHANNEL FRAMED MIRROR/SHELF COMBO	-
10	B-2111	BOBRICK CLASSIC SERIES SURFACE MOUNTED SOAP SATIN FINISH DISPENSER, STAINLESS STEEL	
11	B-212	BOBRICK CLOTHES HOOK AND BUMPER	-

12	B-282 25	BOBRICK CLASSIC SERIES SURFACE MOUNTED SANITARY NAPKIN/TAMPON VENDOR	-
13	B-254	BOBRICK CLASSIC SERIES SURFACE MOUNTED SANITARY NAPKIN DISPOSAL	-
14	B-2892	BOBRICK CLASSIC SERIES SURFACE MOUNTED TWIN JUMBO ROLL TOILET TISSUE DISPENSER	-
15	B-221	BOBRICK CLASSIC SERIES SURFACE MOUNTED SEAT - COVER DISPENSER	-
16	B-2400	33 GAL BOBRICK FLOOR STANDING LARGE CAPACITY WASTE RECEPTICAL	-
17	XL-SB	XCELERATOR WALL MOUNTED AUTOMATIC HAND DRYER	BRUSHED STAINLESS STEEL
18	KB200	KOALA HORIZONTAL BABY CHANGING STATION, SURFACE MOUNT, WHITE GRANITE	-
19	63M	MUSTEE JAN MOP SINK	SAME AS KITCHEN

**ROOM FINISH SCHEDULE**

<b>NO.</b>	<b>DESCRIPTION</b>	<b>FLOOR</b>	<b>BASE</b>	<b>WALLS (N,E,S,W)</b>	<b>CEILING (MAT,HT)</b>	<b>NOTES</b>
101	STORAGE/PREP	VSF3	-	FRP1, FRP1, FRP1, FRP1	GYP, P1, 8'-9"	-
102	TOILET	VSF1	-	CWT1, CWT1, CWT1, CWT1	GYP, P1, VARIES	-
103	KITCHEN	VSF3	-	FRP1, FRP1, FRP1, FRP1	GYP, P1, 8'-9"	-
104	WOMEN'S ROOM	VSF2	CTB2	CWT2/P3, CWT2, CWT2, CWT2/P3	GYP, P1, 8'-9"	-
105	JANITOR	VSF3	-	P3, P3, P3, P3	GYP, P1, 8'-9"	-
106	MEN'S ROOM	VSF1	CTB1	CWT1/P3, CWT1/P3, CWT1, CWT1	GYP, P1, 8'-9"	-
107	SODA	CONC	RCB1	P4, P4, P4, P4	GYP, P1, 8'-9"	-
108	STAIR	RST1	-	P2, P2, P2, P2	GYP, P1, 7'-6"	-
201	STORAGE	VSF3	-	P2, P2, P2, P2	GYP, P1, VARIES	-

**COLOR KEY MANUFACTURER GUIDE**

<b>ITEM</b>	<b>MANUFACTURER</b>	<b>MODEL/TYPE</b>	<b>COLOR &amp; FINISH</b>	<b>REMARKS</b>
<b>WALLS</b>				
CWT1	CROSSVILLE	COLOR BLOX 6X12	A1105 YELLOW BRICK ROAD	RUNNING BOND PATTERN
CWT2	CROSSVILLE	COLOR BLOX 6X12	A1103 SLINKY	RUNNING BOND PATTERN
P1	SHERWIN WILLIAMS	HARMONY	CEILING WHITE, FLAT	-
P2	SHERWIN WILLIAMS	HARMONY	SW7021 SIMPLE WHITE, EGGSHELL	-
P3	SHERWIN WILLIAMS	HARMONY	SW7072 ONLINE, SEMI-GLOSS	TRIM
P4	SHERWIN WILLIAMS	EXTERIOR GRADE	SW7021 SIMPLE WHITE, SEMI-GLOSS	-
FRP1	MARLITE	STANDARD FRP	STANDARD, PEBBLE FINISH WHITE	-
<b>FLOORS</b>				
VSF1	ALTRO	AQUARIUS VINYL SAFETY FLOORING	CORAL CRAB	-
VSF2	ALTRO	AQUARIUS VINYL SAFETY FLOORING	SPOONBILL	-
VSF3	ALTRO	ATLAS SAFETY FLOORING	ANVIL	COVE UP WALL 6"
RST1	JOHNSONITE	RUBBER STAIR TREAD 71 W/INTEGRATED RISER	STORM CLOUD, RAISED ROUND TREAD/RISER	-



**BASE**

CTB1	CROSSVILLE	COLOR BLOX 6X12 COVE BASE	YELLOW BRICK ROAD	-
CTB2	CROSSVILLE	COLOR BLOX 6X12 COVE BASE	SLINKY	-
RCB	JOHNSONITE	4" TRADITIONAL COVE BASE	71 STORM CLOUD	-

**CEILINGS**

GYP	-	-	P2	-
-----	---	---	----	---

**ROOM FINISH LEGEND:****FLOOR FINISHES**

CONC= CONCRETE

CT= CERAMIC TILE

RST= RUBBER STAIR TREAD

VSF=VINYL SAFETY FLOOR

**WALL FINISHES**

CWT= CERAMIC WALL TILE

GYP= GYPSUM WALL BOARD

P= PAINT

FRP=FIBERGLASS REINFORCED PANELS

**CEILING FINISHES**

GYP= GYPSUM WALL BOARD

**BASE FINISHES**

CTB= CERAMIC TILE BASE

RCB= RUBBER COVE BASE

# PRESCOTT PARK: PAVILION BUILDING

## PORTSMOUTH-NEW HAMPSHIRE

### ARCHITECTURE:

McHENRY ARCHITECTURE PLLC  
4 MARKET STREET  
PORTSMOUTH, NEW HAMPSHIRE 03801  
PHONE: 603-430-0274

### CIVIL ENGINEER:

CMA ENGINEERS  
35 BOW STREET  
PORTSMOUTH, NEW HAMPSHIRE 03801  
PHONE: 603-431-6196

### MECHANICAL, ELECTRICAL, AND PLUMBING ENGINEER:

SEACOAST CONSULTING ENGINEERS, LLC  
261 JENNIE LANE  
ELIOT, MAINE  
PHONE: 207-370-7230

Prescott Park  
Pavilion Building  
Portsmouth, NH



### LIST OF DRAWINGS

#### ARCHITECTURAL

- T1 LIST OF DRAWINGS, ABBREVIATIONS, LEGEND, & GENERAL NOTES
- T2 CODE REVIEW, WALL TYPES & MOUNTING HEIGHTS
- T3 SCHEDULES
- A1 FLOOR PLANS & DEMOLITION PLAN
- A2 ROOF & KITCHEN EQUIPMENT PLAN
- A3 REFLECTED CEILING PLANS
- A4 ELEVATIONS
- A5 BUILDING SECTIONS
- A6 BUILDING SECTIONS
- A7 BUILDING SECTIONS
- A8 BUILDING SECTIONS
- A9 BUILDING SECTIONS
- A10 WALL SECTIONS
- A11 WALL SECTIONS

#### CIVIL

- C1 EXISTING CONDITIONS PLAN
- C2 PROPOSED SITE PLAN

#### STRUCTURAL

- S0.0 GENERAL STRUCTURAL NOTES
- S0.1 SCHEDULE OF SPECIAL INSPECTIONS
- S1.0 FOUNDATION PLAN
- S2.0 FLOOR AND ROOF FRAMING PLANS

#### ELECTRICAL

- E1 ELECTRICAL SYMBOLS, LEGEND, NOTES, LIGHTING SCHEDULE
- E1A SPECIFICATIONS, SCOPE OF WORK, UTILITY SERVICES RISER DIAGRAM
- E2 POWER, FIRE ALARM & TEL/DATA RISER DIAGRAMS, GROUNDING DIAGRAM
- E3 MECHANICAL CIRCUIT SCHEDULES, TYPICAL DEVICE MOUNTING HEIGHTS DETAIL
- E4 PAVILION 1ST & 2ND FLOOR PLANS – POWER & TELE/DATA
- E5 PAVILION 1ST & 2ND FLOOR – RCP –LIGHTING
- E6 NOT ISSUED
- E7 SUPPORT BUILDING PLAN & PAVILION – FIRE ALARM

#### MECHANICAL

- M1 FIRST, SECOND & ROOF PLANS & NOTES
- M2 VENTILATION DETAILS & SCHEDULES

#### PLUMBING

- P1.0 PLUMBING LEGENDS, ABBREVIATIONS AND SCHEDULES
- P1.1 PLUMBING PLANS AND SCHEDULE
- P1.2 PLUMBING PLAN AND SPECIFICATIONS
- P1.3 PLUMBING PLAN AND RISER DIAGRAM

### ABBREVIATIONS:

3D	THREE DIMENSIONAL	INSUL	INSULATION, INSULATED
&	AND	INT	INTERIOR
@	AT	LB	POUND
A/V	AUDIO VISUAL	LIN	LINEAR
±	PLUS OR MINUS	MAT	MATERIAL
∠	STEEL ANGLE	MAX	MAXIMUM
ALUM, AL	ALUMINUM	MDF	MEDIUM DENSITY FIBER BOARD
AFF	ABOVE FINISHED FLOOR	MECH	MECHANICAL
APPROX	APPROXIMATE	MFR	MANUFACTURER
ASST	ASSISTANT	MIN	MINIMUM
BD	BOARD	MO	MASONRY OPENING
BL	BORROWED LIGHT	MR	MOISTURE RESISTANT
BLDG	BUILDING	MTD	MOUNTED
BF	BARRIER FREE	MTL	METAL
BSMT	BASEMENT	NAT	NATURAL
CLG	CEILING	NIC	NOT IN CONTRACT
℄	CENTERLINE	NO, #	NUMBER
CL	CLEAR	NTS	NOT TO SCALE
CL	CLOSET	OC	ON CENTER
CMU	CONCRETE MASONRY UNIT	OD	OUTSIDE DIAMETER
CO	CLEANOUT	OH	OPPOSITE HAND
COL	COLUMN	OPP	OPPOSITE
CONF	CONFERENCE	OSB	ORIENTED STRAND BOARD
CONT	CONTINUOUS	PLUMB	PLUMBING
CONC	CONCRETE	PLYWD	PLYWOOD
COORD	COORDINATE	PLAM	PLASTIC LAMINATE
CORR	CORRIDOR	PREFAB	PREFABRICATED
CPT	CARPET	PT	PRESSURE TREATED
CPTT	CARPET TILE	PNT	PAINT
CRK	CORK	RB	RUBBER BASE
CT	CERAMIC TILE	RCB	RUBBER COVE BASE
CTB	CERAMIC TILE BASE	RCP	REFLECTED CEILING PLAN
DIA	DIAMETER	RD	ROOF DRAIN
DN	DOWN	REINF	REINFORCED
DS	DOWNSPOUT	RM	ROOM
DWG(S)	DRAWING(S)	RO	ROUGH OPENING
EA	EACH	S	SOUTH
EJC	EXPANSION JOINT COVER	SS	STAINLESS STEEL
ELEC	ELECTRICAL	SCH	SCHEDULE
ELEV, EL	ELEVATION	SF	SQUARE FEET
EQ	EQUAL	SIM	SIMILAR
EQUIP	EQUIPMENT	SQ	SQUARE
EXIST	EXISTING	SS	STAINLESS STEEL
EXT	EXTERIOR	STL	STEEL
FD	FLOOR DRAIN	STN	STAIN
FDN	FOUNDATION	STOR	STORAGE
FIN	FINISH	STRUCT	STRUCTURAL, STRUCTURE
FF	FINISH FLOOR	SYS	SYSTEM
FL, FLR	FLOOR	TEL	TELEPHONE
GA	GAUGE	TOC	TOP OF CURB
GLAZ	GLAZING	TOS	TOP OF STEEL
GYP	GYPSON	TYP	TYPICAL
GYP BD	GYPSON BOARD	VTR	VENT THROUGH ROOF
HDWD	HARDWOOD	VERT	VERTICAL
HDWR, HDW	HARDWARE	VIF	VERIFY IN FIELD
HM	HOLLOW METAL	W/	WITH
HORIZ	HORIZONTAL	WB	WHITE BOARD
HP	HIGH POINT	WD	WOOD
HSS	HOLLOW STRUCTURAL SECTION	WT	WEIGHT
IN	INCH		
HR	HOUR		

### GENERAL CONSTRUCTION NOTES:

1. WORK INCLUDED IN THIS CONTRACT SHALL CONFORM TO STATE, NATIONAL AND OTHER CODES AND ORDINANCES WHICH APPLY TO THIS PROJECT.
2. VERIFY EXISTING CONDITIONS AND DIMENSIONS AND REPORT DISCREPANCY(IES) TO THE ARCHITECT. THE CONTRACTOR SHALL PROCEED WITH THE WORK ONLY AFTER THE DISCREPANCY(IES) HAS/HAVE BEEN RESOLVED BY THE ARCHITECT.
3. DIMENSIONS ARE FROM FACE OF FRAMING TO FACE OF FRAMING UNLESS NOTED OTHERWISE. DIMENSIONS INDICATED AS "CLEAR" SHALL MAINTAIN A CLEAR OPENING WIDTH FROM FACE OF FINISHES.
4. WORK FROM GIVEN DIMENSIONS AND LARGE SCALE DETAILS ONLY. DO NOT SCALE DRAWINGS.
5. ROOM NUMBERS ON PLANS ARE FOR REFERENCE ONLY AND MAY NOT CORRESPOND TO ACTUAL ROOM NUMBERS AT THE SITE.
6. THE LOCATION OF DOOR OPENINGS NOT DIMENSIONED SHALL BE 6" FROM ADJACENT WALL (FACE OF FRAMING TO ROUGH OPENING).
7. PROVIDE BLOCKING BEHIND SURFACE APPLIED FIXTURES, TRIM, GRAB BARS, SHELVES, CHAIR RAILS, PICTURE RAILS, WOOD TRIM AND BASE, AND OTHER ACCESSORIES WHEN MOUNTED ON STUD WALLS.
8. OVERLAP AIR AND WATER BARRIER 1'-0" (MIN) AT CORNERS, SPLICES, JOINTS AND WITH ROOF VAPOR BARRIER.
9. PERMITS ARE THE RESPONSIBILITY OF THE CONTRACTOR AND SHALL BE COORDINATED WITH THE LOCAL BUILDING OFFICIALS.

### LEGEND

- INTERIOR ELEVATION NUMBERS
- DISCIPLINE SHEET NUMBER WHERE ELEVATIONS ARE DRAWN
- BUILDING SECTION NUMBER SHEET WHERE BUILDING SECTION IS REFERENCED OR DRAWN
- ADDITIONAL SHEET(S) WHERE BUILDING SECTION IS REFERENCED

- ELEVATION OR WALL SECTION NUMBER SHEET WHERE ELEVATION OR WALL SECTION IS REFERENCED OR DRAWN
- ADDITIONAL SHEETS WHERE ELEVATION OR WALL SECTION IS REFERENCED
- DETAIL OR SECTION NUMBER SHEET WHERE DETAIL OR SECTION NUMBER IS REFERENCED OR DRAWN
- ADDITIONAL SHEET(S) WHERE DETAIL OR SECTION IS REFERENCED

- OFFICE ROOM NUMBER
- DOOR NUMBER
- WINDOW TYPE
- CHANGE IN FLOOR FINISH

- ELEVATION OR VERTICAL HEIGHT TARGET
- KEYNOTE
- DETAIL NUMBER
- DISCIPLINE SHEET NUMBER WHERE DETAIL IS DRAWN

PROJECT:  
KEY:

McHENRY  
ARCHITECTURE  
4 Market Street  
Portsmouth, New Hampshire  
603.430.0274

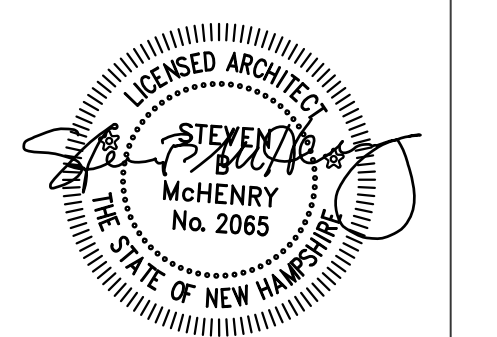

REVISIONS:  
BID SET

PROJECT NAME: Prescott Park Pavilion Building Portsmouth, NH  
PROJECT NO.: 10014  
DRAWN BY: JU  
APPROVED BY: SMcH  
ISSUE DATE: 16SEP12013

DRAWING NAME: LIST OF DRAWINGS, ABBREVIATIONS, LEGEND & GENERAL NOTES

SCALE: 1/4" = 1'-0"  
DRAWING NO.: T1

# GENERAL CODE COMPLIANCE REVIEW

STATE OF NEW HAMPSHIRE

**STATE BUILDING CODE:**

INTERNATIONAL BUILDING CODE 2009 (IBC2009)

**LIFE SAFETY CODE:**

SAF-C 6000  
NATIONAL FIRE PROTECTION AGENCY  
LIFE SAFETY CODE HANDBOOK 2009  
(NFPA LIFE SAFETY 2009)

**STATE ENERGY CODE:**

INTERNATIONAL ENERGY CONSERVATION CODE 2009 (IECC2009)

**STATE MECHANICAL CODE:**

INTERNATIONAL MECHANICAL CODE 2009 (IMC2009)

**STATE ELECTRICAL CODE:**

NATIONAL ELECTRICAL CODE 2005 (NFPA70-2005)

**STATE PLUMBING CODE:**

INTERNATIONAL PLUMBING CODE 2009 (IPC2009)

**STATE ACCESSIBILITY CODE:**

ANSI - A117.1 - 2003  
INTERNATIONAL BUILDING CODE 2009 (IBC2009)

BUILDING DATA	
LOWER LEVEL GROSS AREA	1,784 SF
UPPER LEVEL GROSS AREA	624 SF
PERIMETER	183'-1"
NUMBER OF STORIES ABOVE GRADE	TWO STORIES
BUILDING HEIGHT	APPROX. 15'-0" (AVG. GRADE TO MID-SLOPE OF ROOF)
CONSTRUCTION TYPE	TYPE 3B
SPRINKLER SYSTEM	NO
OCCUPANCY USE GROUP	B - BUSINESS
SEPARATED USE	NO
SEPARATED USE	NO
HEIGHT AND AREA LIMITATIONS (NH MODIFICATIONS)	(TABLE 503 NHBSC 2009)
BASIC HEIGHT LIMITATIONS	2 STORIES, 30'-0"
PROPOSED TOTAL HEIGHT	2 STORIES, 15'-0"
BASIC AREA LIMITATIONS	(TABLE 503 NHBSC 2009)
OCCUPANCY USE GROUP	S1 = 8,400 SF PER FLOOR
PROPOSED TOTAL AREA	2,408 SF
ELEVATOR REQUIRED	NO
MEANS OF EGRESS REQUIREMENTS	
OCCUPANT LOAD	(TABLE 7.3.1.2, NFPA 101)
PRIMARY USE	BUSINESS (B) = 18 PERSONS STORAGE (S1) = 1 PERSON
TOTAL BUILDING OCCUPANT LOAD	19 PERSONS
MINIMUM NUMBER OF EXITS REQUIRED	(40.2.4, NFPA 101)
	BUSINESS (B) = 1 (38.2.4.3 NFPA 101) STORAGE (S1) = 1 (42.2.4.1 NFPA 101)
NUMBER OF EXITS PROVIDED	BUSINESS (B) = 2 STORAGE (S1) = 1
REQUIRED EGRESS WIDTH AT DOORS	36" PROVIDED (7.3.4 NFPA 101)
REQUIRED EGRESS WIDTH AT STAIR	42" MIN. PROVIDED (7.2.2.2.1.2 NFPA 101)
MAXIMUM DEAD-END CORRIDOR	50'-0" MAX (S1) (MOST RESTRICTIVE) (TABLE A.7.6, NFPA 101)
MAXIMUM COMMON PATH OF TRAVEL	50'-0" MAX (S1) (TABLE A.7.6, NFPA 101)
MAXIMUM TRAVEL DISTANCE	(S1) = 250'-0" (47'-0" MAX PROVIDED) (TABLE A.7.6, NFPA 101)
MINIMUM CORRIDOR WIDTH	36" PROVIDED (7.3.4, NFPA 101)
FIRE RATINGS	
	TYPE 3B CONSTRUCTION
EXTERIOR BEARING WALLS	2 HOUR (TABLE 601, IBC 2009)
INTERIOR BEARING WALLS	0 HOUR (TABLE 601, IBC 2009)
FLOOR CONSTRUCTION	0 HOUR (TABLE 601, IBC 2009)
ROOF CONSTRUCTION	0 HOUR (TABLE 601, IBC 2009)
STRUCTURAL FRAME	0 HOUR (TABLE 601, IBC 2009)

## BASIC CODE INFORMATION:

**GENERAL PROJECT DESCRIPTION:**

THE PROJECT CONSISTS OF ADDITIONS AND RENOVATIONS TO THE EXISTING CONCESSIONS/BATHROOMS BUILDING AT PRESCOTT PARK IN PORTSMOUTH, NH.

BUILDING CODES REFERENCED: IBC 2009 AND NFPA 101 LIFE SAFETY CODE 2009

NOTE: PER STATE OF NH LAW, THE HEIGHT AND AREA LIMITATIONS OF BOCA 1999, TABLE 503 WITH NEW HAMPSHIRE MODIFICATIONS HAVE BEEN RETAINED. THE MOST RECENT EDITION OF LIFE SAFETY CODE, NFPA 101 TAKES PRECEDENCE ON THE DESIGN OF EGRESS. SECTION REFERENCES ARE FROM IBC UNLESS NOTED OTHERWISE

## STANDARD MOUNTING HEIGHTS:

SCALE: 1/4" = 1'-0"

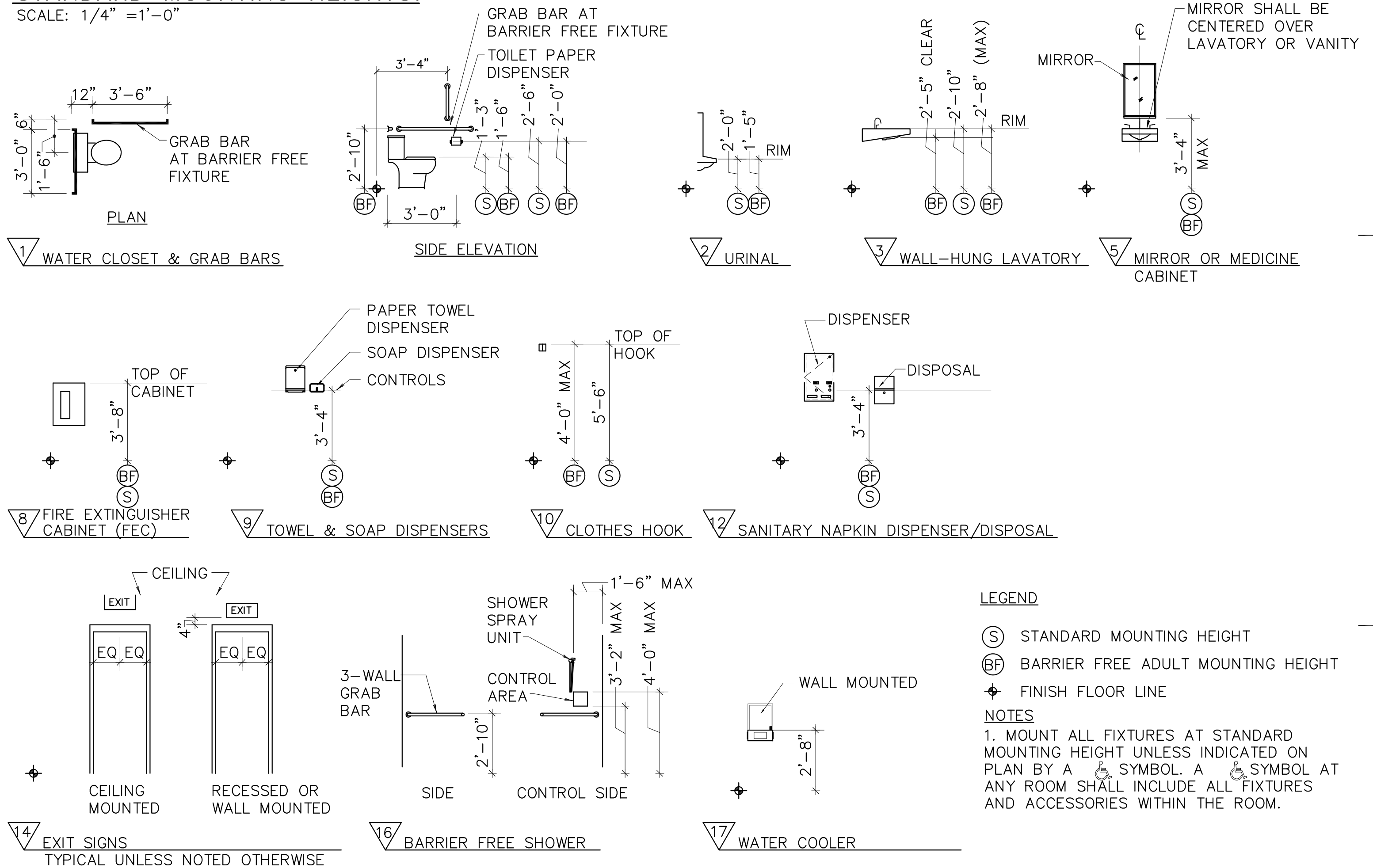

## WALL TYPES:

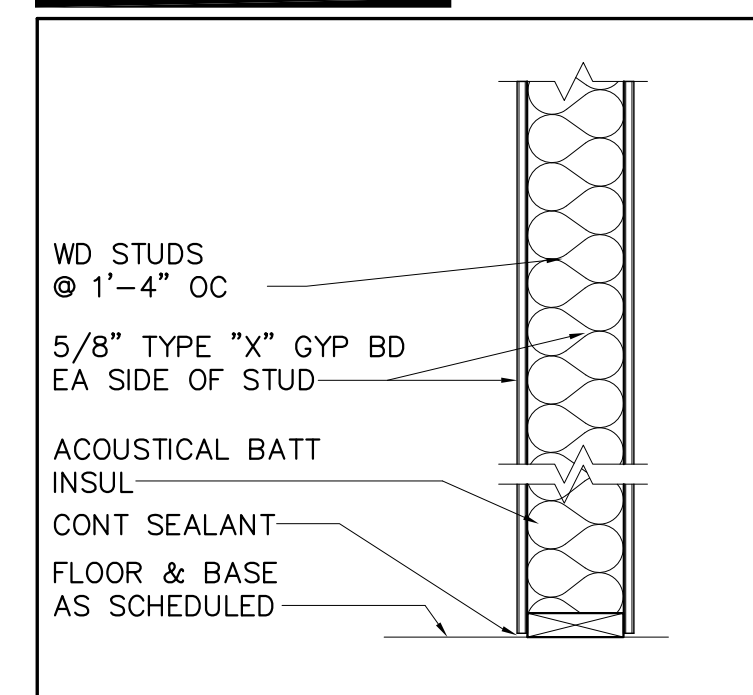

2x6" WOOD STUD-FULL HEIGHT  
1 HOUR RATED

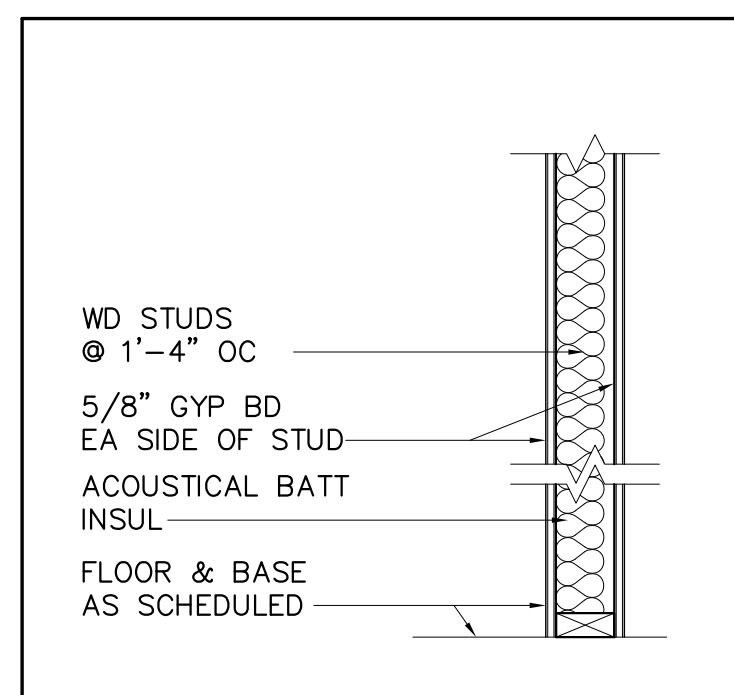

2x6" WOOD STUD-FULL HEIGHT

2x4" WOOD STUD-FULL HEIGHT

2x6" WOOD STUD-FULL HEIGHT  
W/GYP ON INTERIOR ONLY

2x4" WOOD STUD-FULL HEIGHT  
W/GYP ON INTERIOR ONLY

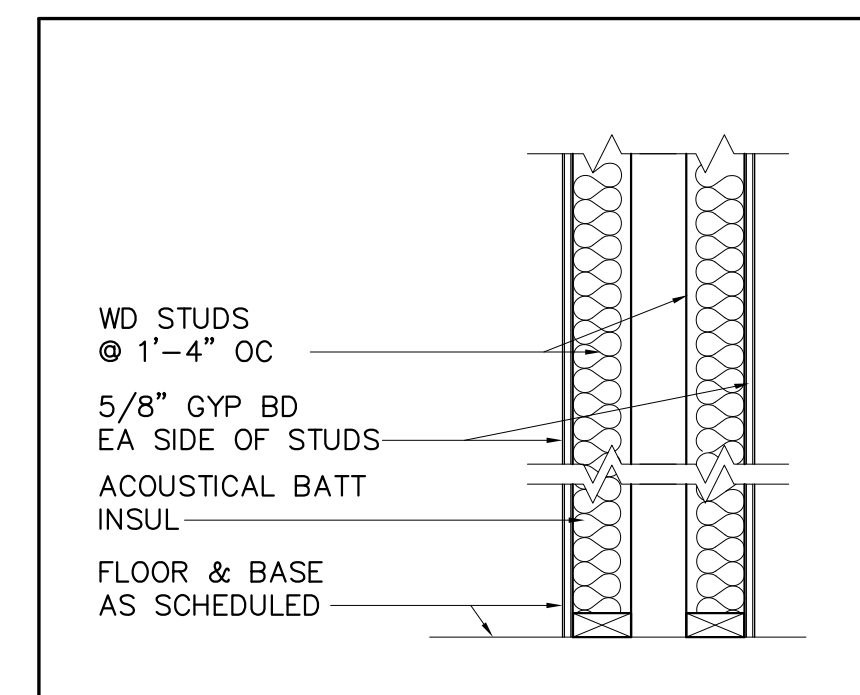

2x4" WOOD STUD-FULL HEIGHT  
PLUMBING WALL

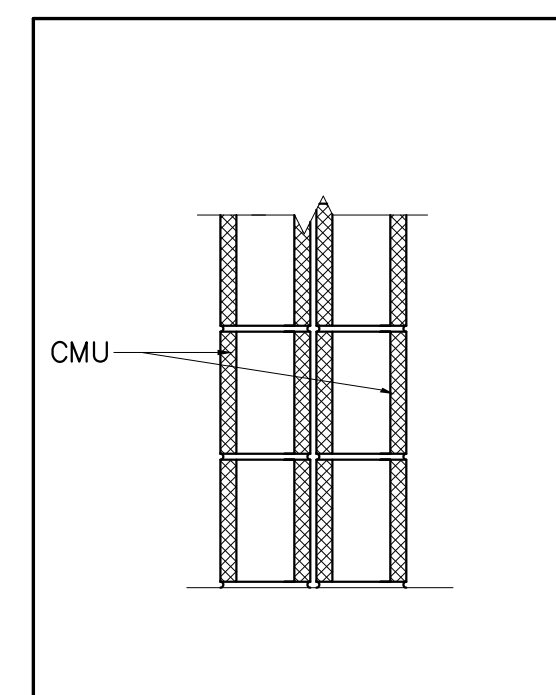

(2) 6" CMU INFILL

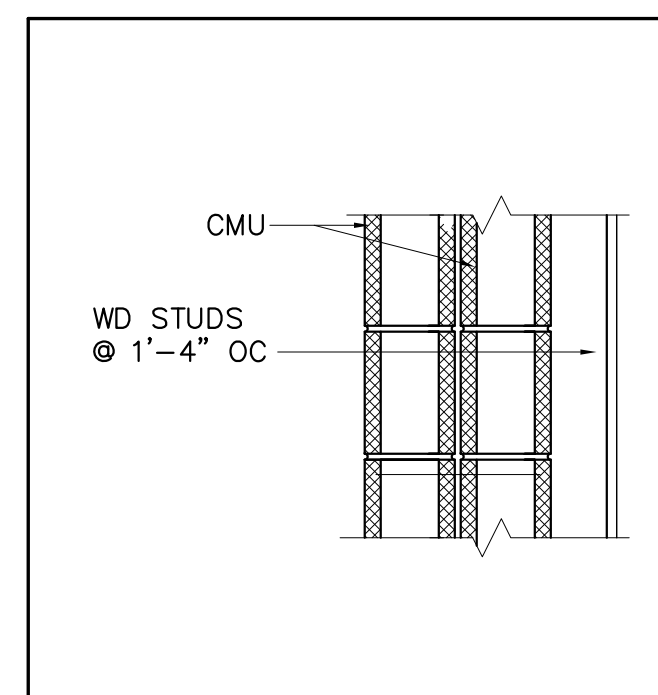

(2) 6" CMU INFILL & 2x4" WOOD STUD PLUMBING WALL

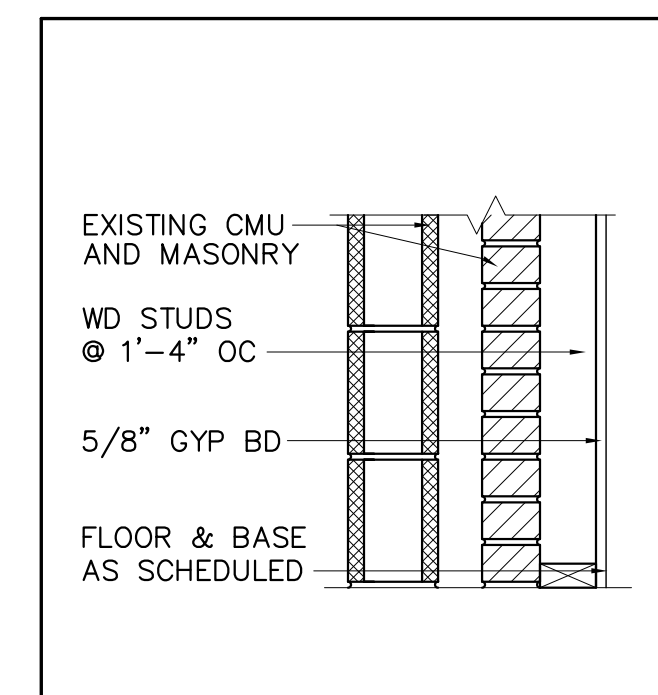

EXISTING CMU/MASONRY WALL &  
2x4" WOOD STUD PLUMBING WALL

**NOTES**

1. PROVIDE MOISTURE RESISTANT GYP BD AT ALL WET AREAS.

Prescott Park  
Pavilion Building  
Portsmouth, NH

PROJECT:  
KEY:

McHENRY  
ARCHITECTURE

4 Market Street  
Portsmouth, New Hampshire  
603.430.0274

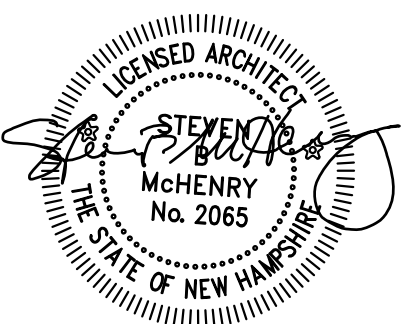

REVISIONS:  
BID SET

PROJECT NAME:  
Prescott Park  
Pavilion Building  
Portsmouth, NH

PROJECT NO.: 10014  
DRAWN BY: JU  
APPROVED BY: SMcH  
ISSUE DATE: 16SEP12013

DRAWING NAME:  
CODE REVIEW, WALL  
TYPES, & MOUNTING  
HEIGHTS

SCALE: 1/4" = 1'-0"

DRAWING NO.:

T2

SHEET NO.: 1 of X

**DOOR SCHEDULE**

NO.	ROOM NAME	DOOR		RATING	SIZE	FRAME		DETAILS		HRDWR	NOTES
		TYPE	MATERIAL			TYPE	MATERIAL	H	S		
1	STAIR 108	1	HM	-	3'-0" x 7'-0"	2	HM	-	-	1,3,7	-
2	WOMEN'S ROOM 104	4	WD	-	3'-9" x 7'-0"	-	-	-	-	2,8,9	-
3	WOMEN'S ROOM 104	1	HM	-	3'-0" x 7'-0"	2	HM	-	-	1,3,7	-
4	MEN'S ROOM 106	1	HM	-	3'-0" x 7'-0"	2	HM	-	-	1,3,7	-
5	MEN'S ROOM 106	4	WD	-	3'-9" x 7'-0"	-	-	-	-	2,8,9	-
6	KITCHEN 103	1	HM	-	3'-0" x 7'-0"	2	HM	-	-	1,3,7	-
7	KITCHEN 103	2	SS	-	3'-0" x 4'-4"	-	SS	-	-	-	COUNTER DR
8	KITCHEN 103	2	SS	-	3'-0" x 4'-4"	-	SS	-	-	-	COUNTER DR
9	KITCHEN 103	2	SS	-	3'-0" x 4'-4"	-	SS	-	-	-	COUNTER DR
10	KITCHEN 103	2	SS	-	3'-0" x 4'-4"	-	SS	-	-	-	COUNTER DR
11	SODA 107	3	SS	-	3'-0" x 7'-0"	-	SS	-	-	-	COUNTER DR
12	STAIR 108	1	HM	-	3'-0" x 7'-0"	1	HM	-	-	1,4,7	-
13	TOILET 102	1	HM	-	2'-6" x 6'-8"	1	HM	-	-	1,5	-
14	JANITOR 105	1	HM	-	2'-6" x 6'-8"	1	HM	-	-	1,6	-
15	STORAGE 201	1	HM	-	3'-0" x 6'-8"	1	HM	-	-	1,4,7	-
16	UNISEX BATH 109	1	HM	-	3'-0" x 7'-0"	2	HM	-	-	1,3,7	-

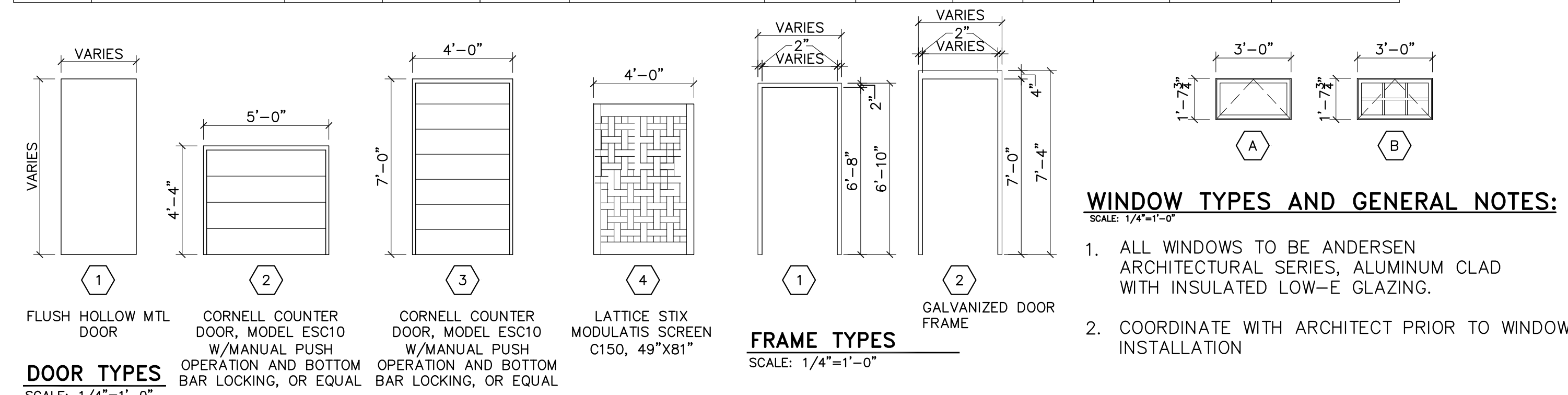

**HARDWARE SCHEDULE**

NO.	DESCRIPTION	MANUFACTURER	MODEL	DESCRIPTION
1	HINGE SET	STANLEY	F179 US26D	3 HINGES, 4-1/2" x 4-1/2", BRUSHED CHROME BALL BEARING
2	HINGE SET- LATTICE GATE	STANLEY	F179 US26D	2 HINGES, 4-1/2" x 4-1/2", BRUSHED CHROME BALL BEARING
3	PUSH PLATE/PULL BAR/DEADBOLT LOCK	ROCKWOOD/SCHLAGE	-	ROCKWOOD PUSH PLATE 70C,PULL PLATE 111X70C STAINLESS STEEL, DEADBOLT LOCK: SCHLAGE B500 SERIES, KEY BOTH SIDES, SATIN CHROME
4	DOOR LEVER/LOCK SET	SCHLAGE	S10D	S-SERIES, STYLE "NEPTUNE", PASSAGE LATCH, FINISH 626 SATIN CHROMIUM PLATED
5	DOOR LEVER/LOCK SET	SCHLAGE	S40D	S-SERIES, STYLE "NEPTUNE", BEDROOM/BATHROOM PRIVACY LOCK, FINISH 626 SATIN CHROMIUM PLATED
6	DOOR LEVER/LOCK SET	SCHLAGE	L9070	L-SERIES, HEAVY DUTY, CLOSET LOCK, FINISH 626 SATIN CHROMIUM PLATED
7	DOOR CLOSER	LCN	P1371	DOOR CLOSER W/ALUMINUM FINISH
8	PAD LOCK	-	-	-
9	HOOK AND EYE FOR GATE	-	-	ED

**ROOM FINISH SCHEDULE**

NO.	DESCRIPTION	FLOOR	BASE	WALLS				CEILING		NOTES
				NORTH	EAST	SOUTH	WEST	MATERIAL	HEIGHT	
101	STORAGE/PREP	VSF3	VSF3	FRP1	FRP1	FRP1	FRP1	GYP, P1	8'-9"	-
102	TOILET	VSF1	CTB1	CWT1	CWT1	CWT1	CWT1	GYP, P1	VARIES	-
103	KITCHEN	VSF3	VSF3	FRP1	FRP1	FRP1	FRP1	GYP, P1	8'-9"	-
104	WOMEN'S ROOM	VSF2	CTB2	CWT2,P3	CWT2	CWT2	CWT2,P3	GYP, P1	8'-9"	-
105	JANITOR	VSF3	VSF3	P3,P5	P3,P5	P3,P6	P3,P6	GYP, P1	8'-9"	-
106	MEN'S ROOM	VSF1	CTB1	CWT1,P3	CWT1,P3	CWT1	CWT1	GYP, P1	8'-9"	-
107	SODA	CONC	RCB1	P4,P6	P4,P6	P4,P6	P4,P6	GYP, P1	8'-9"	-
108	STAIR	RST1	RCB1	P2,P5	P2,P5	P2,P5	P2,P5	GYP, P1	7'-6"	-
201	STORAGE	VSF3	VSF3	P2,P5	P2,P5	P2,P5	P2,P5	GYP, P1	VARIES	-

**COLOR KEY MANUFACTURER GUIDE**

ITEM	MANUFACTURER	MODEL/TYPE	COLOR & FINISH	REMARKS
<b>WALLS</b>				
CWT1	CROSSVILLE	COLOR BLOX 6X12	A1105 YELLOW BRICK ROAD	RUNNING BOND PATTERN
CWT2	CROSSVILLE	COLOR BLOX 6X12	A1103 SLINKY	RUNNING BOND PATTERN
P1	SHERWIN WILLIAMS	HARMONY	CEILING WHITE, FLAT	-
P2	SHERWIN WILLIAMS	HARMONY	SW7021 SIMPLE WHITE, EGGSHELL	-
P3	SHERWIN WILLIAMS	HARMONY	SW7072 ONLINE, SEMI-GLOSS	TRIM
P4	SHERWIN WILLIAMS	EXTERIOR GRADE	SW7021 SIMPLE WHITE, SEMI-GLOSS	-
P5	SHERWIN WILLIAMS	HARMONY	WALL PRIMER	PRIMER-FOR GYP WALLS
P6	SHERWIN WILLIAMS	PREP-RITE BLOCK FILLER	WHITE	CMU BLOCK FILLER PRIMER
FRP1	MARLITE	STANDARD FRP	STANDARD, PEBBLE FINISH WHITE	-
<b>FLOORS</b>				
VSF1	ALTRO	AQUARIUS VINYL SAFETY FLOORING	CORAL CRAB	-
VSF2	ALTRO	AQUARIUS VINYL SAFETY FLOORING	SPOONBILL	-
VSF3	ALTRO	ATLAS SAFETY FLOORING	ANVIL	COVE UP WALL 6"
RST1	JOHNSONITE	RUBBER STAIR TREAD W/INTEGRATED RISER	71 STORM CLOUD, RAISED ROUND TREAD/RISER	-
<b>BASE</b>				
CTB1	CROSSVILLE	COLOR BLOX 6X12 COVE BASE	YELLOW BRICK ROAD	-
CTB2	CROSSVILLE	COLOR BLOX 6X12 COVE BASE	SLINKY	-
RCB1	JOHNSONITE	4" TRADITIONAL COVE BASE	71 STORM CLOUD	-
<b>CEILING</b>				
GYP	-	-	P2	-
<b>MISC</b>				
-	-	-	-	-

**BATHROOM FIXTURE AND ACCESSORY SCHEDULE**

ITEM	MODEL #	DESCRIPTION	NOTES
1	2854.128	AMERICAN STANDARD MADERA ADA 1.28 GPF AND MANUAL FLUSH VALVE, FLOOR MOUNTED TOILET	-
2	6590.125	AMERICAN STANDARD WASHBROOK 0.125 GPF URINAL WITH MANUAL FV	-
3	4869.004	AMERICAN STANDARD REGALYN ENAMELED CAST IRON WALL HUNG SINK	-
4	5502.170	AMERICAN STANDARD MONTERREY CENTERSET LAVATORY FAUCET W/GRID DRAIN	-
5	-	GLOBAL FLOOR ANCHORED/OVERHEAD BRACED STAINLESS STEEL TOILET PARTITIONS	#4 SATIN FINISH
6	B-5806x36	36" HORIZONTAL BOBRICK SERIES CONCEALED MOUNTING W/SNAP FLANGE GRAB BAR	PEENED NON-SLIP GRIPPING SURFACE
7	B-5806x42	42" HORIZONTAL BOBRICK SERIES CONCEALED MOUNTING W/SNAP FLANGE GRAB BAR	PEENED NON-SLIP GRIPPING SURFACE
8	B-5806x18	18" VERTICAL BOBRICK SERIES CONCEALED MOUNTING W/SNAP FLANGE GRAB BAR	PEENED NON-SLIP GRIPPING SURFACE
9	B-166 2436	24"x36" BOBRICK CLASSIC SERIES CHANNEL FRAMED MIRROR/SHELF COMBO	-
10	B-2111	BOBRICK CLASSIC SERIES SURFACE MOUNTED SOAP DISPENSER, STAINLESS STEEL	SATIN FINISH
11	B-212	BOBRICK CLOTHES HOOK AND BUMPER	-
12	B-282 25	BOBRICK CLASSIC SERIES SURFACE MOUNTED SANITARY NAPKIN/TAMPON VENDOR	-
13	B-254	BOBRICK CLASSIC SERIES SURFACE MOUNTED SANITARY NAPKIN DISPOSAL	-
14	B-2892	BOBRICK CLASSIC SERIES SURFACE MOUNTED TWIN JUMBO ROLL TOILET TISSUE DISPENSER	-
15	B-221	BOBRICK CLASSIC SERIES SURFACE MOUNTED SEAT COVER DISPENSER	-
16	B-2400	33 GAL BOBRICK FLOOR STANDING LARGE CAPACITY WASTE RECEPTICAL	-
17	XL-SB	XCELERATOR WALL MOUNTED AUTOMATIC HAND DRYER	BRUSHED STAINLESS STEEL
18	KB200	KOALA HORIZONTAL BABY CHANGING STATION, SURFACE MOUNT, WHITE GRANITE	-
19	63M	MUSTEE JAN MOP SINK	SAME AS KITCHEN

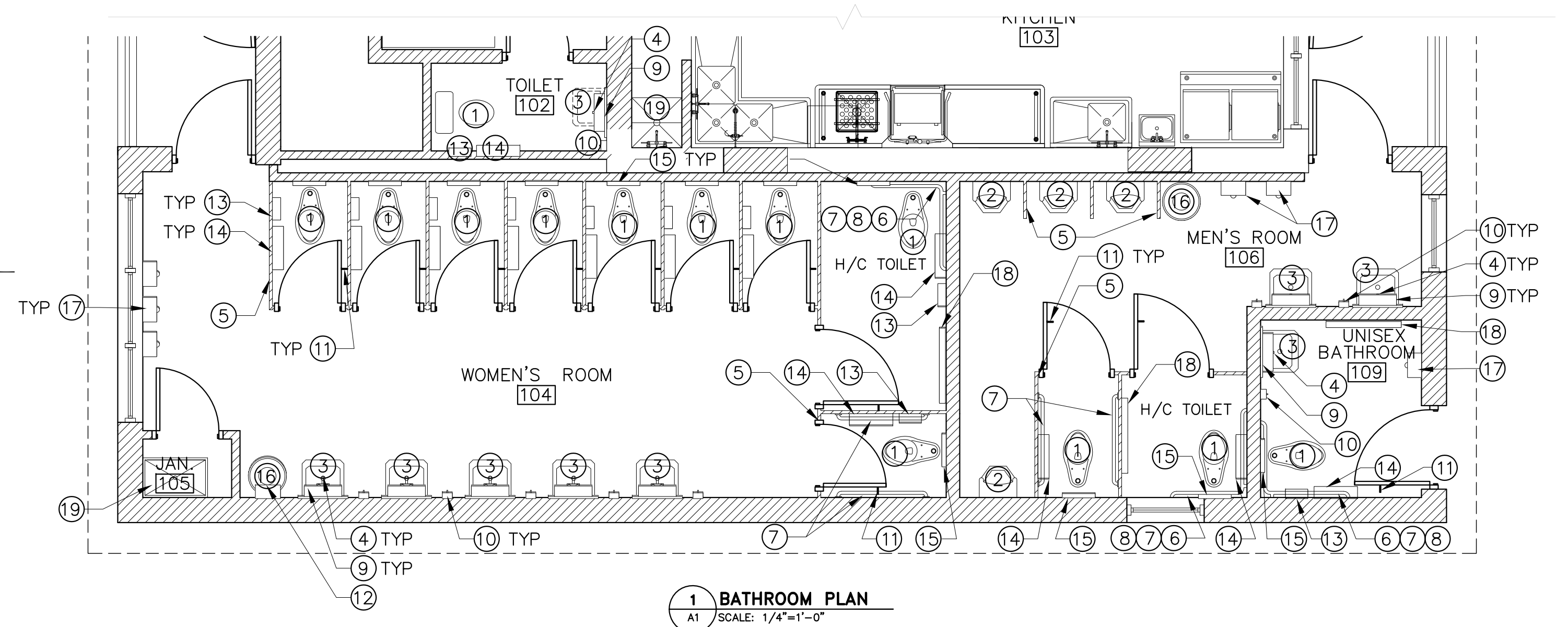

**ROOM FINISH GENERAL NOTES:**

- MANUFACTURER'S NAMES AND CATALOG NUMBERS ARE USED TO PROVIDE AN INDICATION OF SURFACE TEXTURES AND COLORS DESIRED. OTHER MANUFACTURER'S PRODUCTS OF SIMILAR SURFACE TEXTURES, COLORS AND MEETING THE SPECIFIED REQUIREMENTS WILL BE ACCEPTABLE.
- CHANGES IN FLOOR FINISHES OCCUR UNDER DOORS TYPICALLY. CHANGES WHICH DO NOT OCCUR AT DOORS ARE INDICATED ON FLOOR PLANS.
- WHERE PATTERNS OR INSTRUCTIONS INDICATE, ARCHITECT SHALL PROVIDE DRAWINGS OR DIRECTIONS FOR FLOOR PATTERNS AND WALL PATTERN DESIGNS.
- ANY ACCESSORY ROOMS NOT LISTED ON THE ROOM FINISH SCHEDULE (CLOSETS, ETC.) SHALL BE PROVIDED WITH THE SAME FINISHES AS THE ADJACENT ROOM.
- UNLESS NOTED OTHERWISE PROVIDE APPROPRIATE TRANSITION STRIPS AT INTERSECTIONS OF DISSIMILAR FLOOR MATERIALS.
- PROVIDE MOISTURE RESISTANT GYP BD AT ALL WET AREAS.

**ROOM FINISH LEGEND:**

- FLOOR FINISHES:**  
CONC= CONCRETE  
CT= CERAMIC TILE  
RST= RUBBER STAIR TREAD  
VSF=VINYL SAFETY FLOOR
- WALL FINISHES:**  
CWT= CERAMIC WALL TILE  
GYP= GYPSUM WALL BOARD  
P= PAINT  
FRP=FIBERGLASS REINFORCED PANELS
- CEILING FINISHES:**  
GYP= GYPSUM WALL BOARD
- BASE FINISHES:**  
CTB= CERAMIC TILE BASE  
RCB= RUBBER COVE BASE
- GENERAL:**  
NIC= NOT IN CONTRACT  
TBD= TO BE DETERMINED

PROJECT:  
KEY:

**McHENRY ARCHITECTURE**

4 Market Street  
Portsmouth, New Hampshire  
603.430.0274

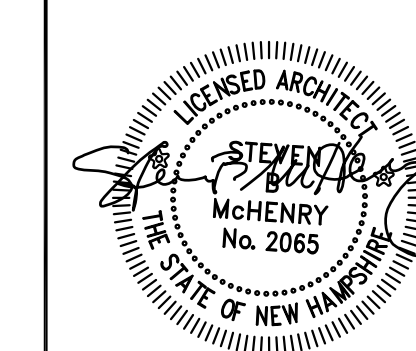

REVISIONS:  
BID SET

PROJECT NAME: Prescott Park Pavilion Building Portsmouth, NH  
PROJECT NO.: 10014  
DRAWN BY: JMU  
APPROVED BY: SMcH  
ISSUE DATE: 16SEP12013  
DRAWING NAME:

SCHEDULES

SCALE: 1/4"=1'-0"  
DRAWING NO.:

**T3**

**Prescott Park Pavilion Building**  
Portsmouth, NH

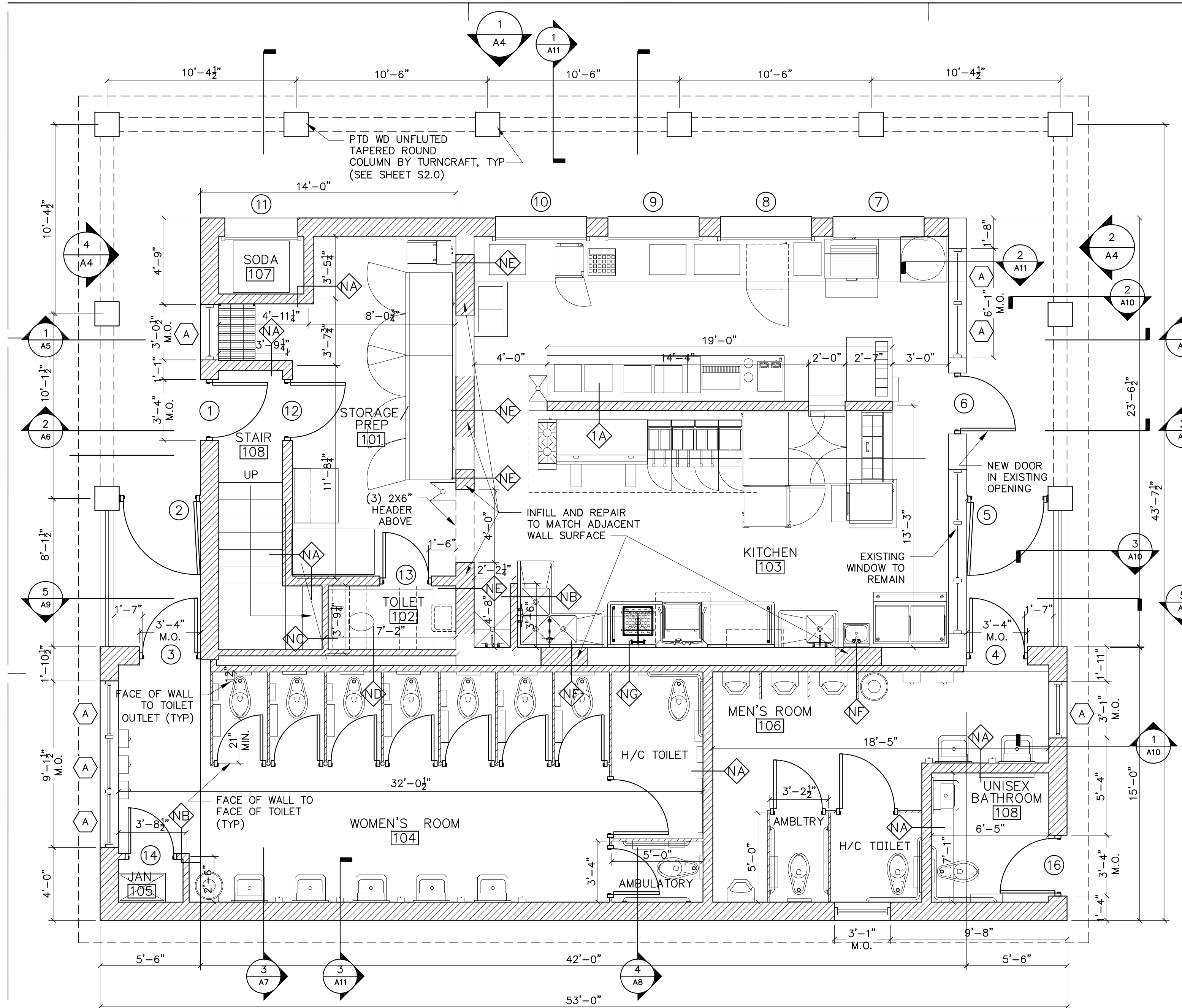

**1 FIRST FLOOR PLAN**  
A1 SCALE: 1/4"=1'-0"

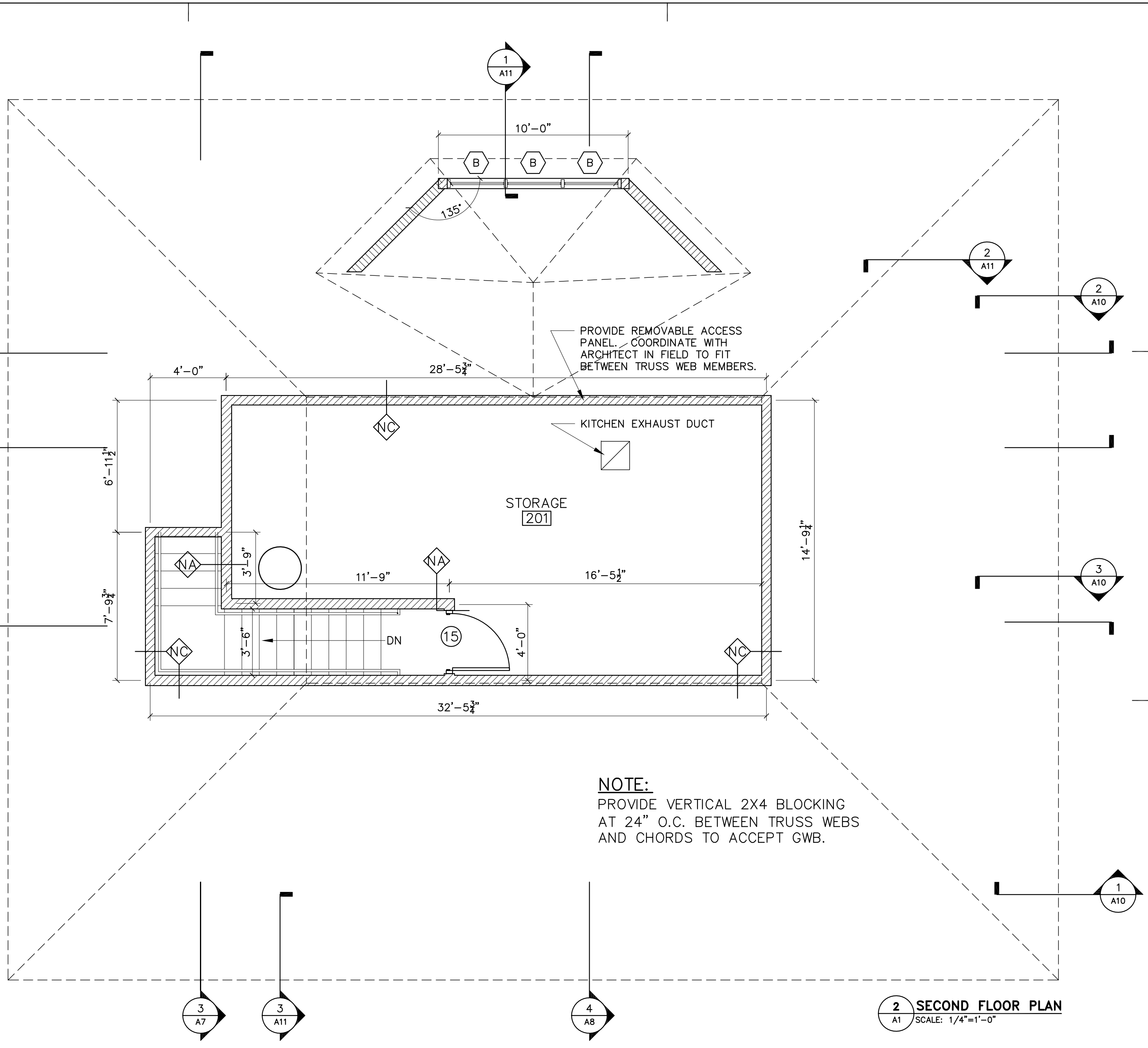
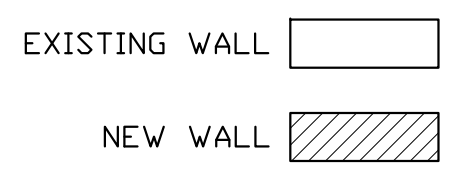

**2 SECOND FLOOR PLAN**  
A1 SCALE: 1/4"=1'-0"

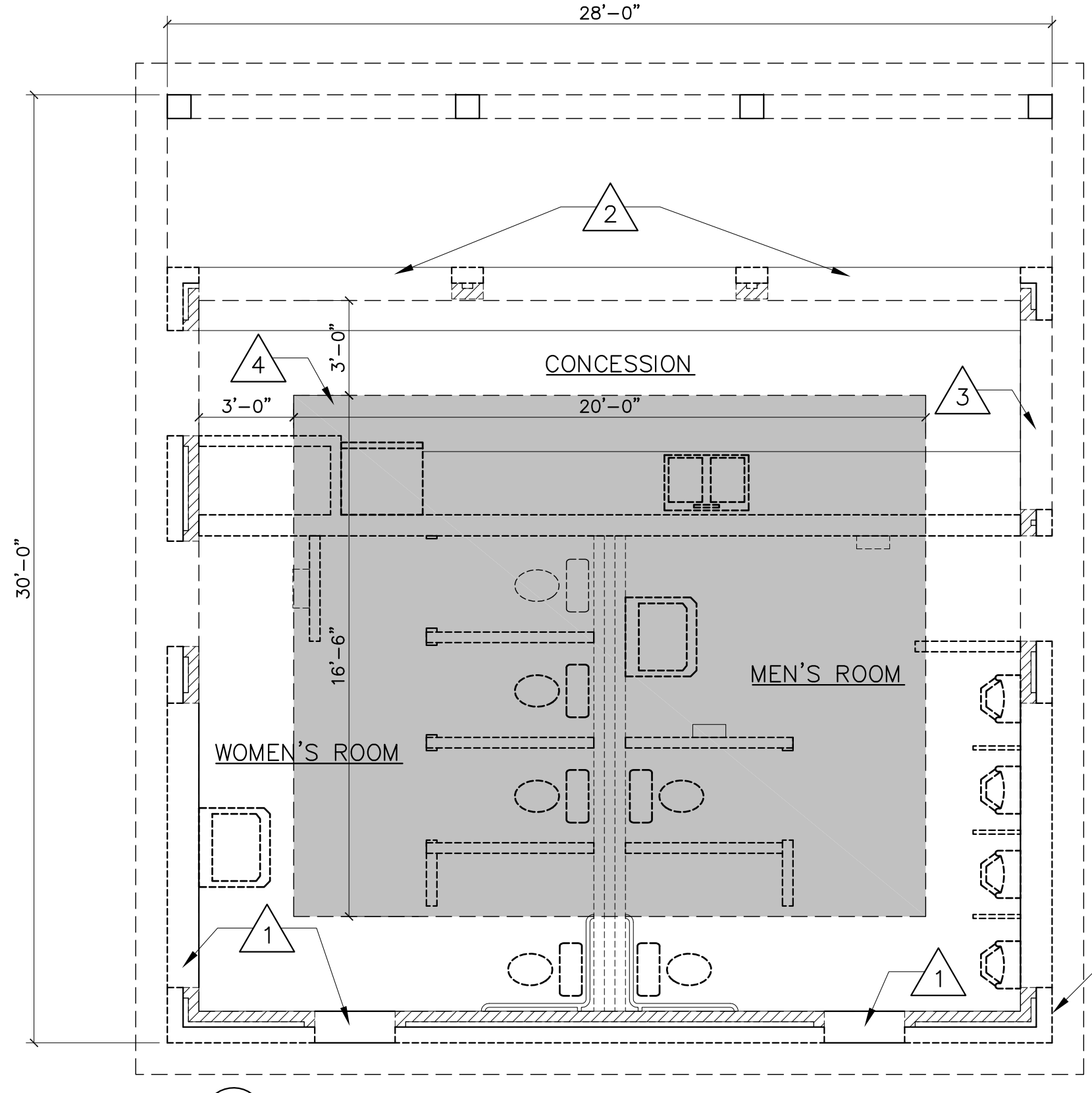

**3 DEMOLITION PLAN**  
A1 SCALE: 1/4"=1'-0"

**NOTE:**  
PROVIDE VERTICAL 2X4 BLOCKING AT 24" O.C. BETWEEN TRUSS WEBS AND CHORDS TO ACCEPT GWB.

**GENERAL REMOVAL NOTES:**

1. REMOVE EXISTING ROOF AND CHIMNEY
2. REMOVE EXISTING INTERIOR WALLS
3. REMOVE EXISTING PLUMBING FIXTURES, PIPING, AND ACCESSORIES
4. REMOVE EXISTING INTERIOR FURNISHINGS
5. REMOVE EXISTING DOORS (INCLUDING ROLLING DOORS)
6. REMOVE EXISTING MTL GUTTER AND DOWNSPOUT
7. REMOVE EXISTING EXTERIOR COLUMNS
8. REMOVE EXISTING PAYPHONES
9. REMOVE EXISTING LIGHT FIXTURES
10. REMOVE EXISTING EXTERIOR WOOD PARTITIONS

**KEYNOTES-REMOVALS:**

- 1 REMOVE EXISTING WINDOW
- 2 REMOVE EXISTING WALL
- 3 REMOVE EXISTING WALL AT NEW WINDOW LOCATION (SEE FLOOR PLAN & WINDOW SCHEDULE FOR LOCATION AND M.O.)
- 4 REMOVE EXISTING SLAB AND REPLACE TO MATCH ADJACENT
- 5 EXISTING ELECTRICAL PANEL POWERS ADJACENT FORMAL GARDENS AND VARIOUS LOCATIONS THROUGHOUT THE PARK. THIS PANEL MUST REMAIN OPERATIONAL DURING DEMOLITION AND CONSTRUCTION UNTIL REROUTING OF ALL LINES INTO THE PANEL HAS BEEN COMPLETED.

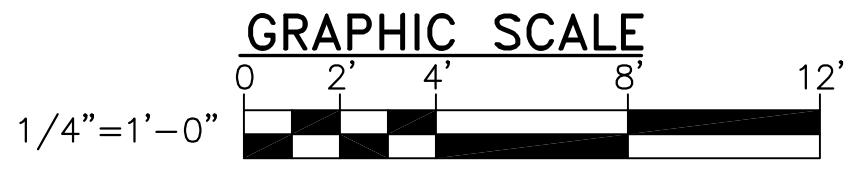

PROJECT:  
KEY:

**McHENRY ARCHITECTURE**  
4 Market Street  
Portsmouth, New Hampshire  
603.430.0274

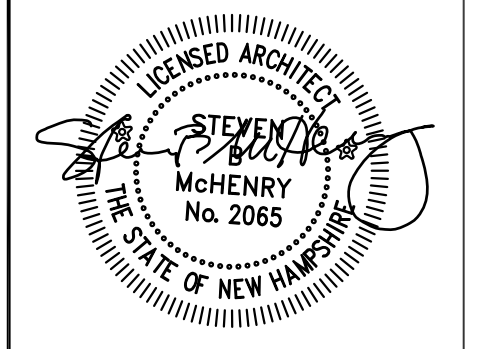

REVISIONS: **BID SET**

PROJECT NAME: Prescott Park Pavilion Building Portsmouth, NH  
PROJECT NO.: 10014  
DRAWN BY: JU  
APPROVED BY: SMcH  
ISSUE DATE: 16SEPT2013  
DRAWING NAME:

**FLOOR PLANS & DEMOLITION PLAN**

SCALE: 1/4"=1'-0"  
DRAWING NO.: **A1**

SHEET NO.: 1 of X

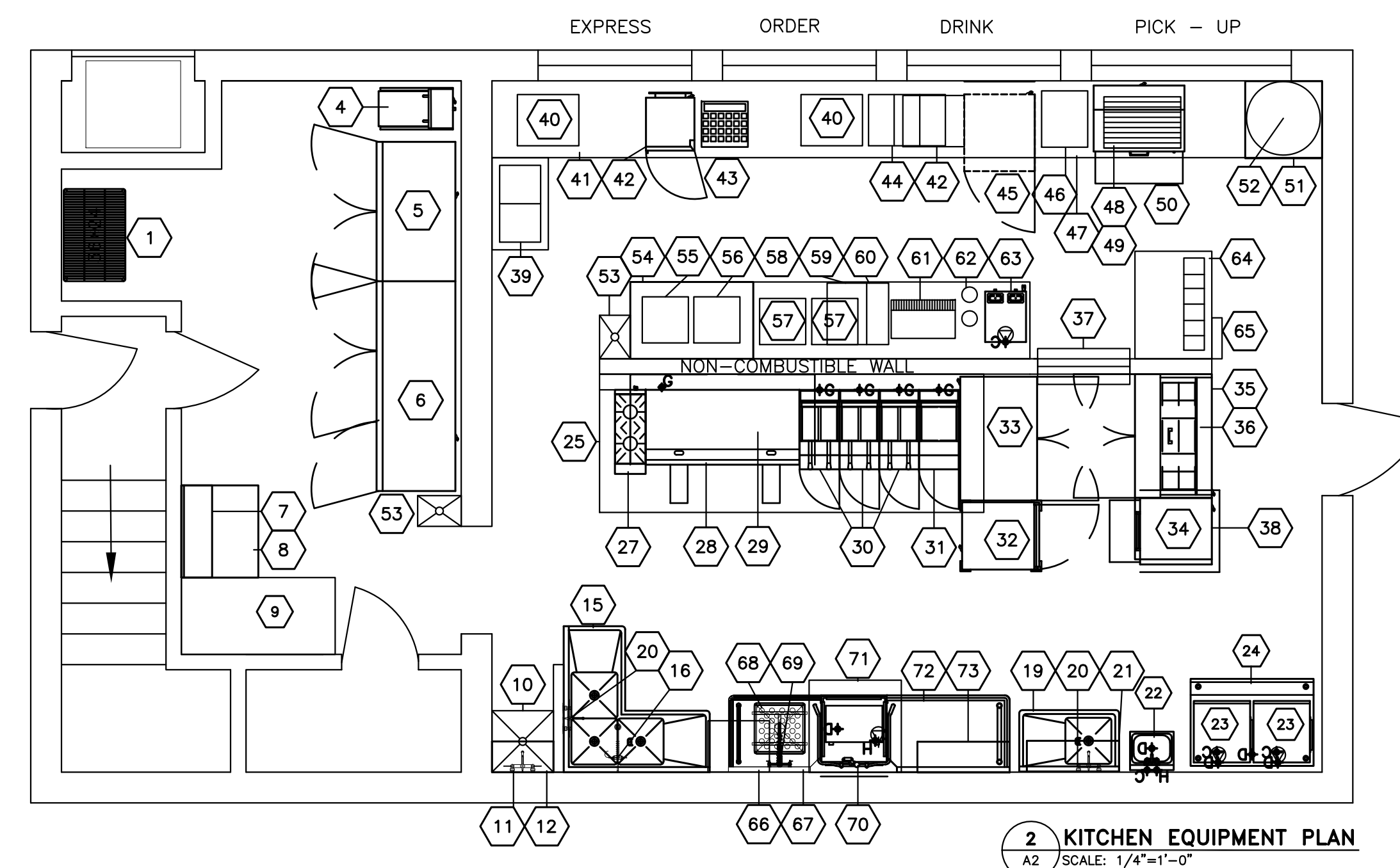

NOTE: ALL KITCHEN EQUIPMENT IS PROVIDED BY OTHERS, AND IS ONLY SHOWN FOR COORDINATION PURPOSES.

SCHEDULE					
Item No	Qty	Equipment Category	Item No	Qty	Equipment Category
1	1	Wire Shelving Unit, NSF	37	1	SHELF, PASS-THRU
2	1	Wire Shelves, NSF	38	1	EQUIPMENT STAND
3	1	Wire Shelving Unit, NSF	39	1	FREEZER ICE CREAM MERCHANDISER
4	1	FRYER FILTER, MOBILE	40	2	COUNTER TOP DISPLAY (CHIPS/CANDY)
5	1	2 DR FREEZER, REACH IN	41	1	WINDOW SRVC LAMINATE COUNTER 25'
6	1	3 DR REFRIGERATOR REACH IN	42	2	REFRIGERATED DRINK DISPLAY U/C
7	2	OVERSHELF, WALL MOUNTED	43	3	CASH REGISTER
8	1	WORK TABLE, 30"	45	1	FREEZER, UNDERCOUNTER, REACH-IN
9	1	CHEST FREEZER	46	1	DISPLAY CASE, PRETZELS COUNTERTOP
10	1	JANITOR'S MOP SERVICE BASIN	47	1	MICROWAVE OVEN
11	1	FAUCET, SERVICE SINK	48/49	1	HOT DOG GRILL & RETHERM DRAWER
12	2	OVERSHELF, WALL MOUNTED	50	1	HOD DOG ROLL WARMER
13	1	WIRE SHELIVING	51	1	EQUIPMENT STAND 30"
14	1	SPARE NUMBER	52	1	COTTON CANDY FLOSS MACHINE
15	1	SINK, THREE COMPARTMENT	53	2	HAND SINK NARROW W/SIDE SPLASH
16	1	PRE-RINSE UNIT	54	1	EQUIPMENT STAND, 4'
17	1	SPARE NUMBER	55	1	PARAGON THEATER POPCORN POPPER
18	1	SPARE NUMBER	56	1	DIPLAY CASE PIZZA, COUNTERTOP
19	1	SINK, ONE COMPARTMENT	57	2	REFRIGERATED DISPLAY CASE CNTRTOP
20	2	FAUCET	58	1	BACK BAR CABINET 9' LAMINATED
21	2	OVERSHELF, WALL-MOUNTED	59	1	BAG IN BOX/SYRUP TANK RACK
22	1	HANDSINK WALL MNTD W/SPLSH GRDS	60	1	CARBONATOR
23	2	ICE MAKER, CUBE-STYLE	61	1	SODA, ICE & BEVERAGE DISPENSER
24	1	ICE BIN	62	1	AIRPOT SERVING RACK
25	1	EXHAUST HOOD & FIRE SYSTEM	63	1	AIR POT COFFEE BREWER
26	1	SPARE NUMBER	64	1	FLAVOR RAIL DIPPING CABINET
27	1	HOTPLATE, COUNTER UNIT, GAS	65	1	SPADEWELL ICE DIPPER STATION
28	1	REFRIGERATED CHEF'S BASE	66	1	SORTING SHELF
29	1	GRIDDLE, COUNTER UNIT, GAS	67	1	SOILED DISH TABLE WITH SINK
30	3	FRYER, FLOOR MODEL, GAS, FULL POT	68	1	PRE-RINSE BASKET
31	1	FRENCH FRY WARMER, BIN TYPE	69	1	PRE-RINSE UNIT
32	1	HOLDING BIN, HEATED	70	1	DISH MACHINE, PASS THROUGH
33	1	FREEZER COUNTER, WORK TOP 4'	71	1	HOOD, CONDENSATE - 42"x42"
34	1	PIZZA OVEN	72	1	CLEAN DISH TABLE
35	1	REFRIGERATED 4' SANDWICH TOP	73	2	WALL SHELF
36	1	OVERSHELF, TABLE MOUNTED			

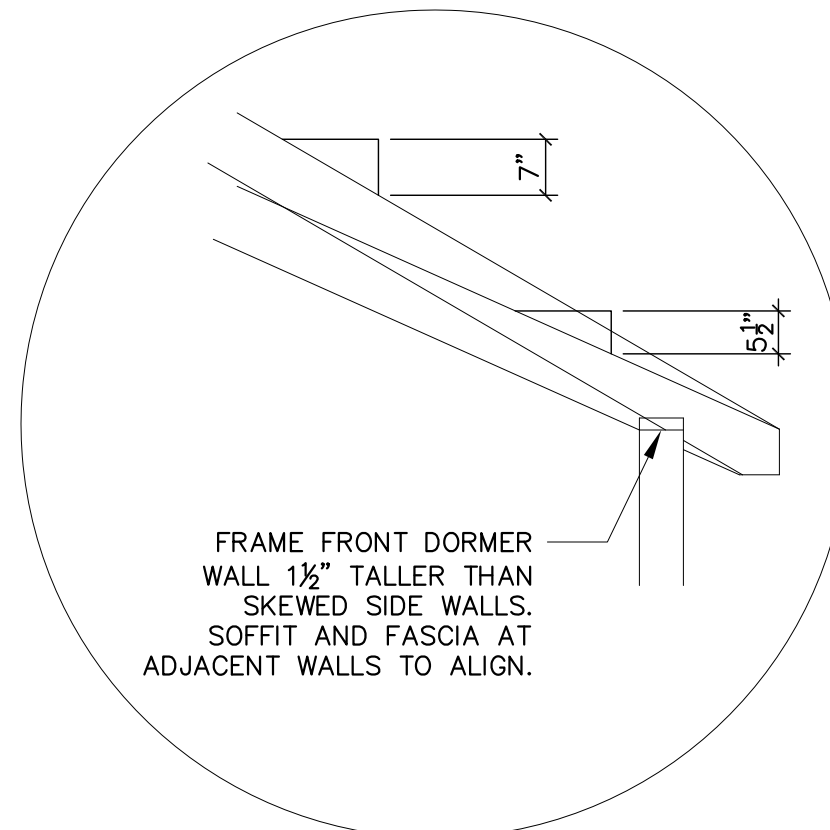
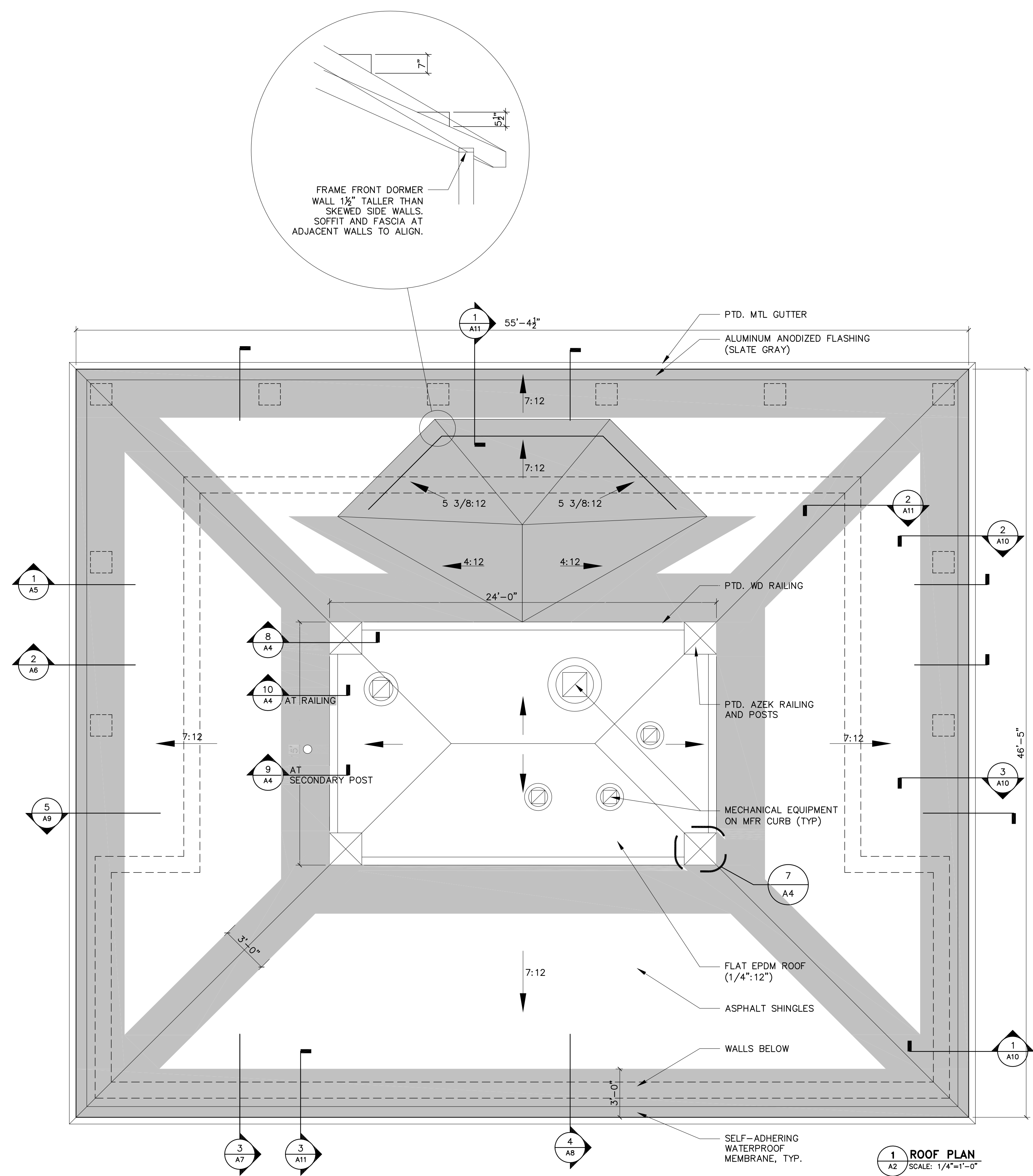

PROJECT:  
KEY:

McHENRY  
ARCHITECTURE  
4 Market Street  
Portsmouth, New Hampshire  
603.430.0274

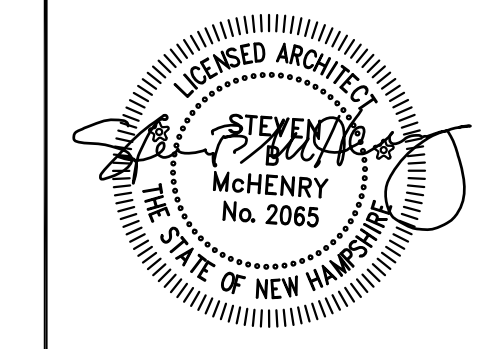

REVISIONS:  
BID SET

PROJECT NAME:  
Prescott Park  
Pavilion Building  
Portsmouth, NH

PROJECT NO.: 10014  
DRAWN BY: JU  
APPROVED BY: SMcH  
ISSUE DATE: 16SEP12013

DRAWING NAME:  
ROOF & KITCHEN EQUIPMENT PLAN

SCALE: 1/4"=1'-0"  
DRAWING NO.:

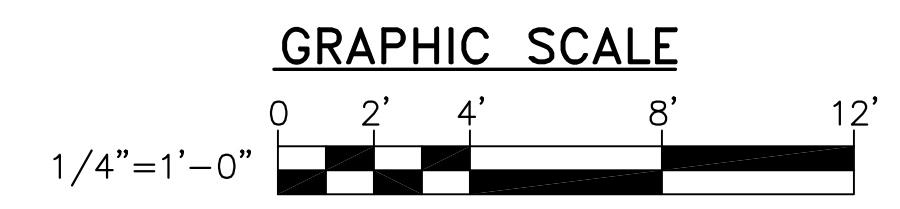

A2

SHEET NO.: 1 of X

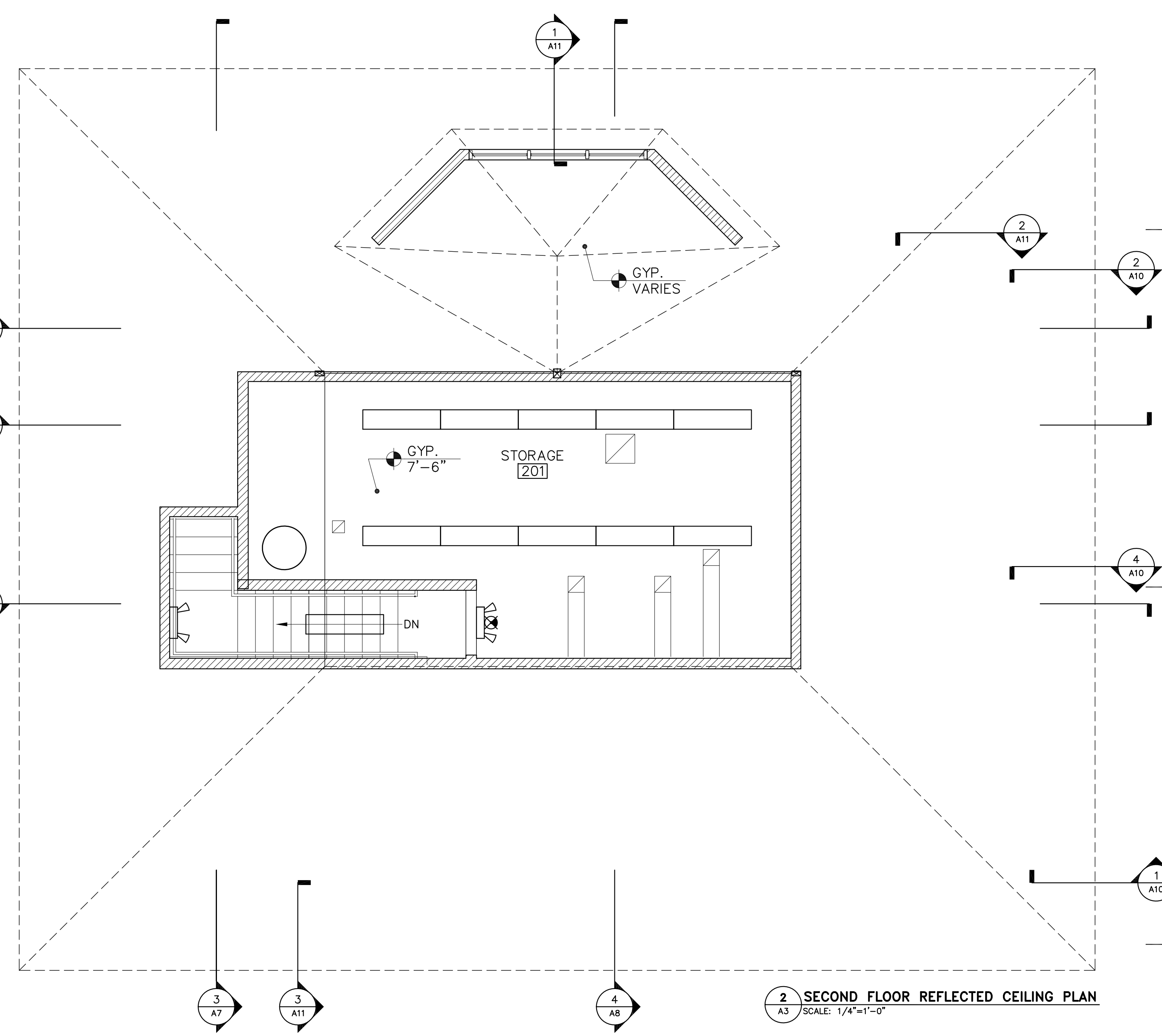
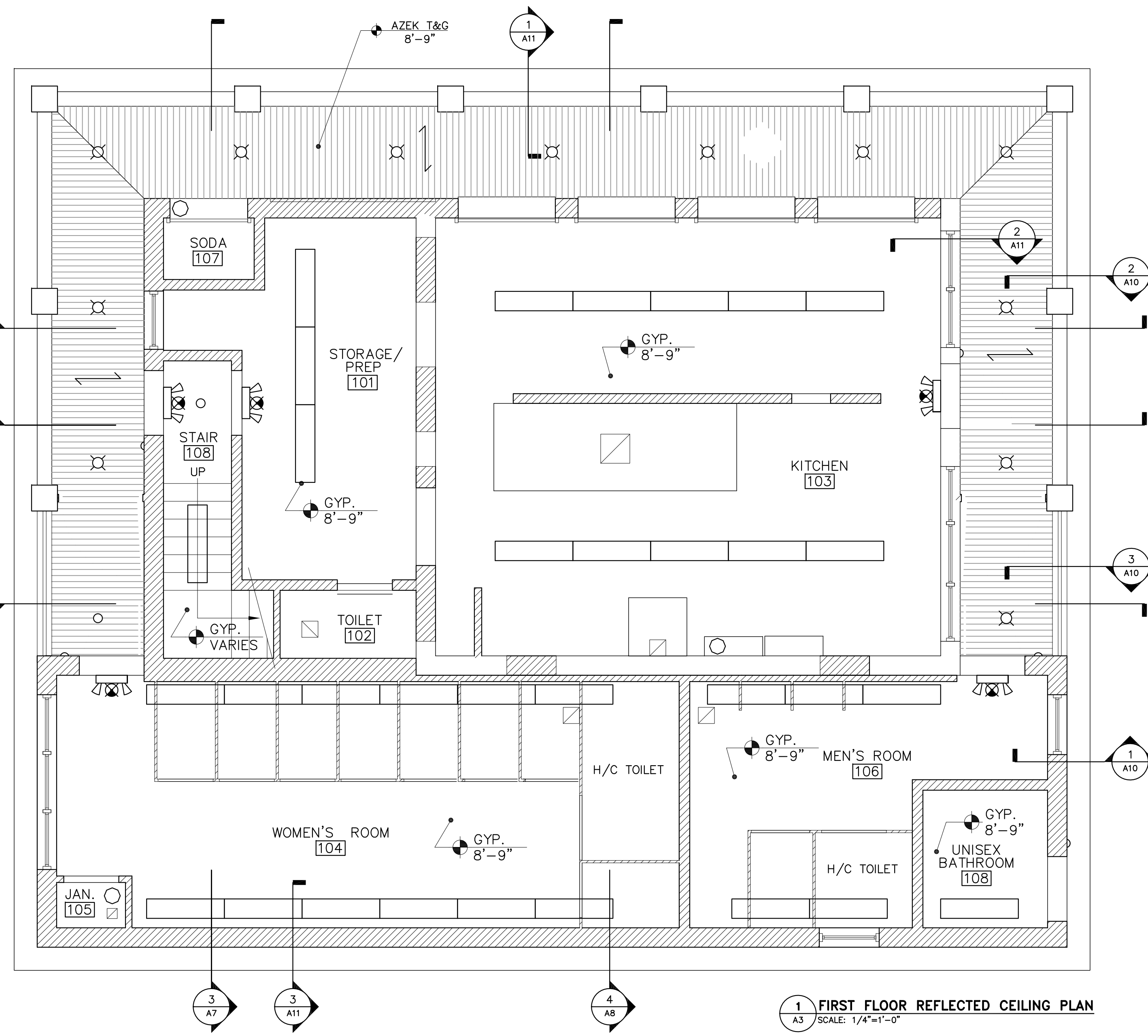

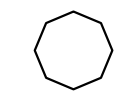
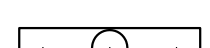
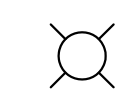

**REFLECTED CEILING PLAN LEGEND**

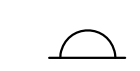
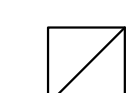
-  PENDANT LIGHT
-  1'-0" x 4'-0" FLUORESCENT LIGHT
-  RECESSED CAN FIXTURE
-  EXIT SIGN
-  WALL SCONCE
-  EXHAUST

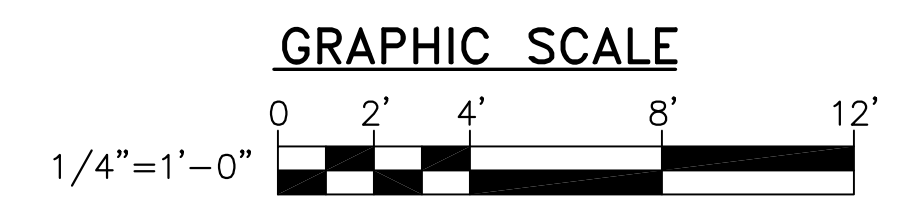

PROJECT:  
KEY:

**McHENRY ARCHITECTURE**  
4 Market Street  
Portsmouth, New Hampshire  
603.430.0274

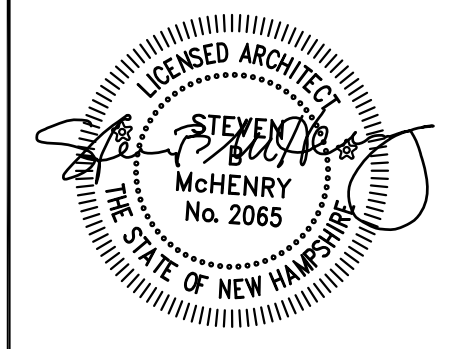

REVISIONS:  
BID SET

PROJECT NAME: Prescott Park Pavilion Building Portsmouth, NH  
PROJECT NO.: 10014  
DRAWN BY: JU  
APPROVED BY: SMcH  
ISSUE DATE: 16SEPT2013  
DRAWING NAME: REFLECTED CEILING PLANS

SCALE: 1/4" = 1'-0"  
DRAWING NO.:

**A3**

# Prescott Park Pavilion Building

Portsmouth, NH

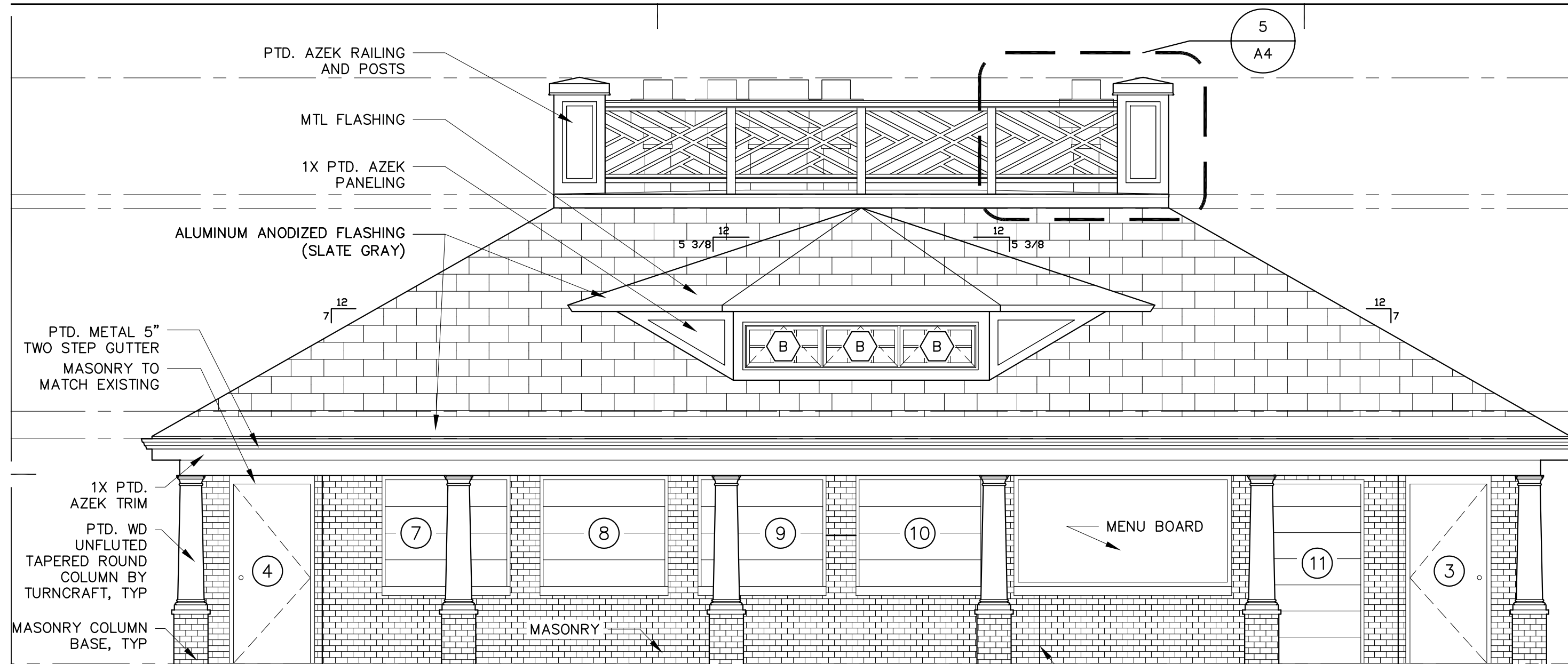

**1 NORTH ELEVATION**  
A4 SCALE: 1/4"=1'-0"

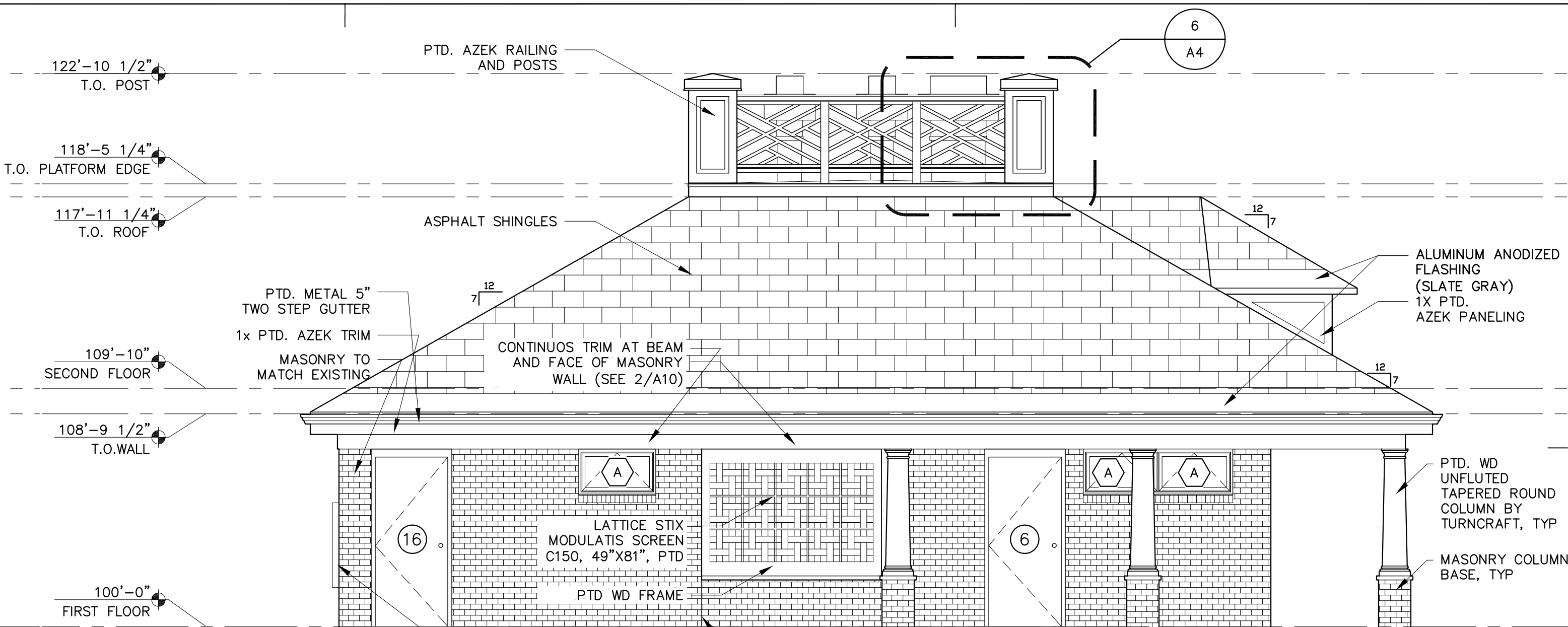

**2 EAST ELEVATION**  
A4 SCALE: 1/4"=1'-0"

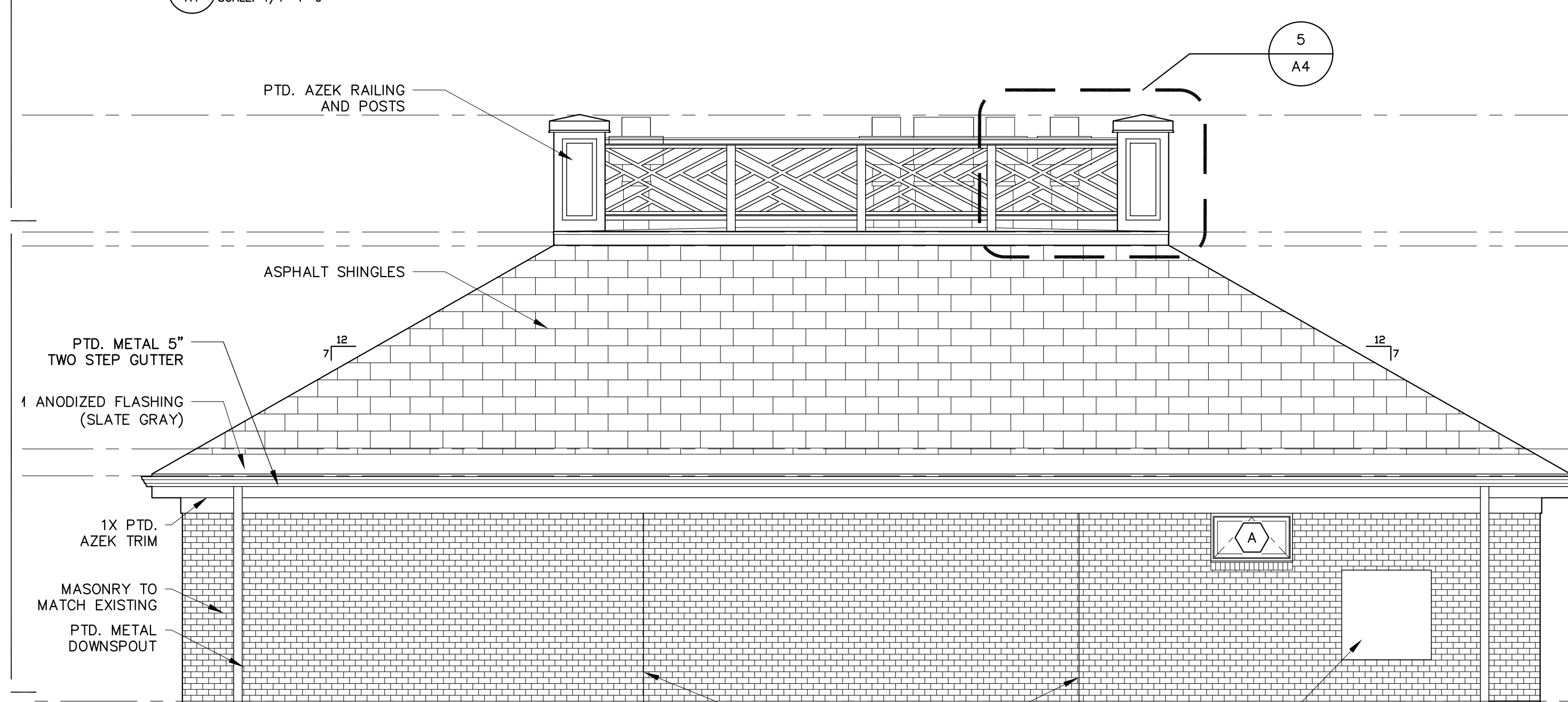

**3 SOUTH ELEVATION**  
A4 SCALE: 1/4"=1'-0"

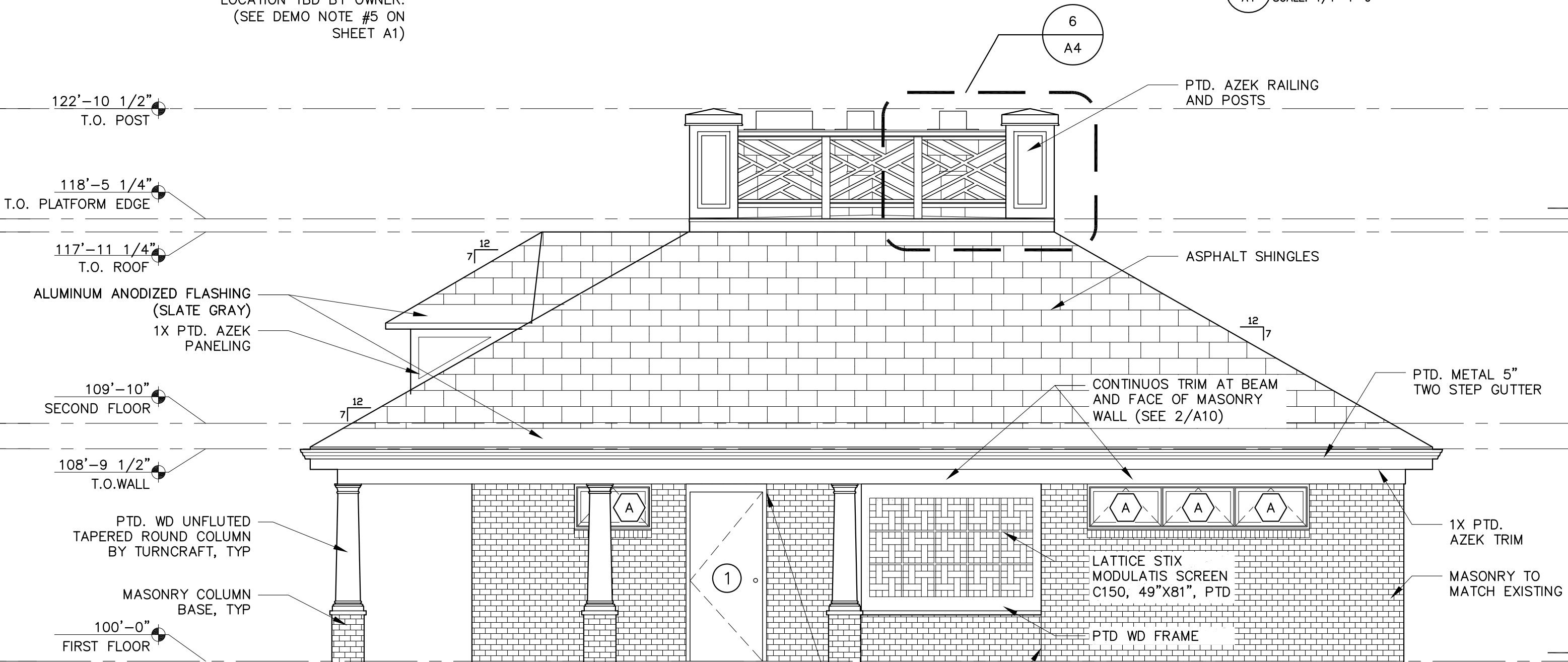

**4 WEST ELEVATION**  
A4 SCALE: 1/4"=1'-0"

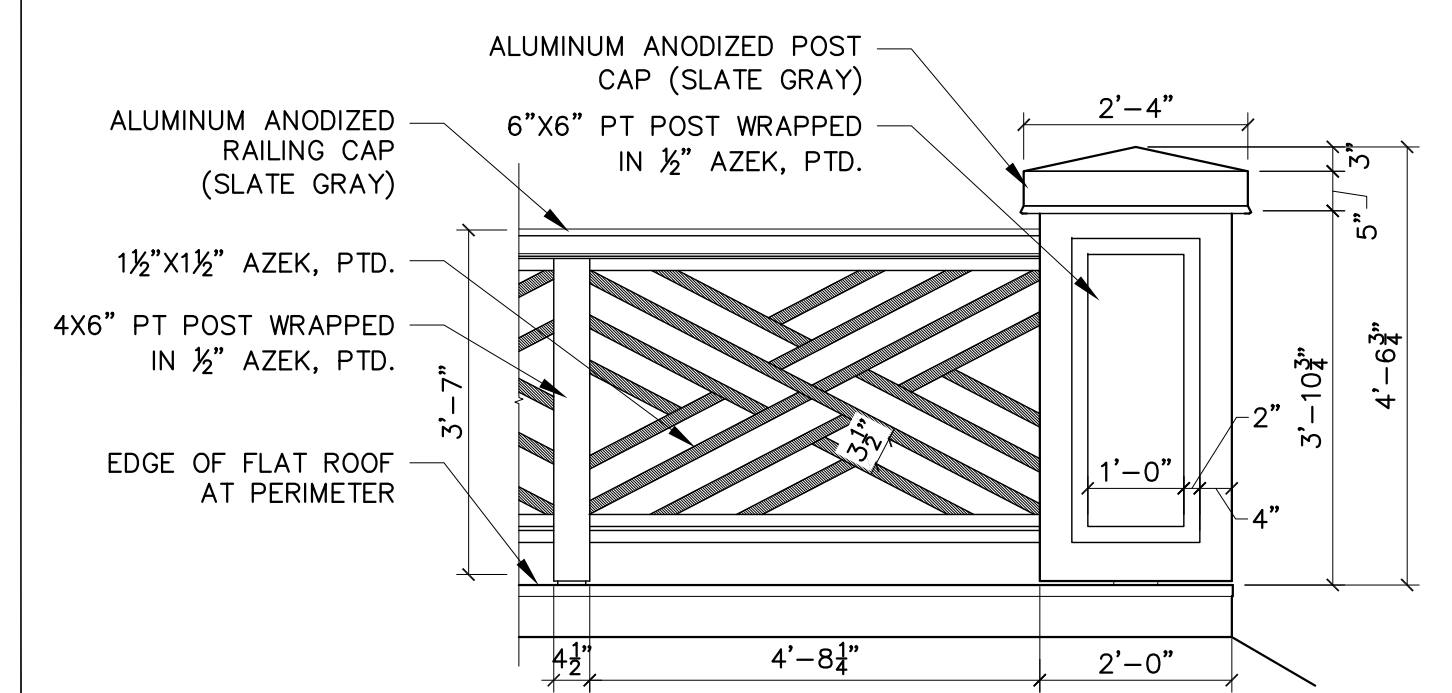

**5 BASKET WEAVE RAILING (NORTH & SOUTH ELEVATIONS)**  
A4 SCALE: 1/2"=1'-0"

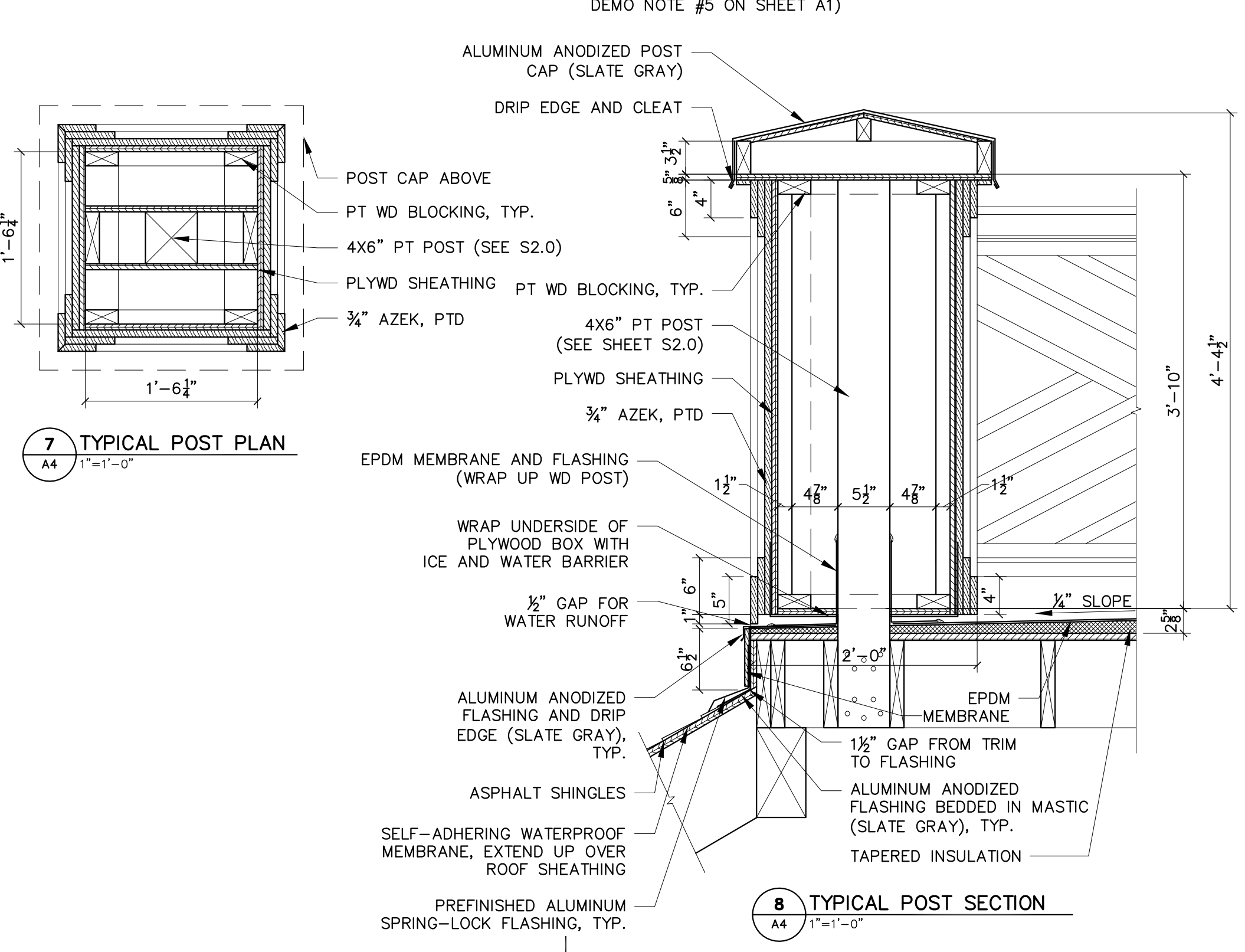

**8 TYPICAL POST SECTION**  
A4 SCALE: 1"=1'-0"

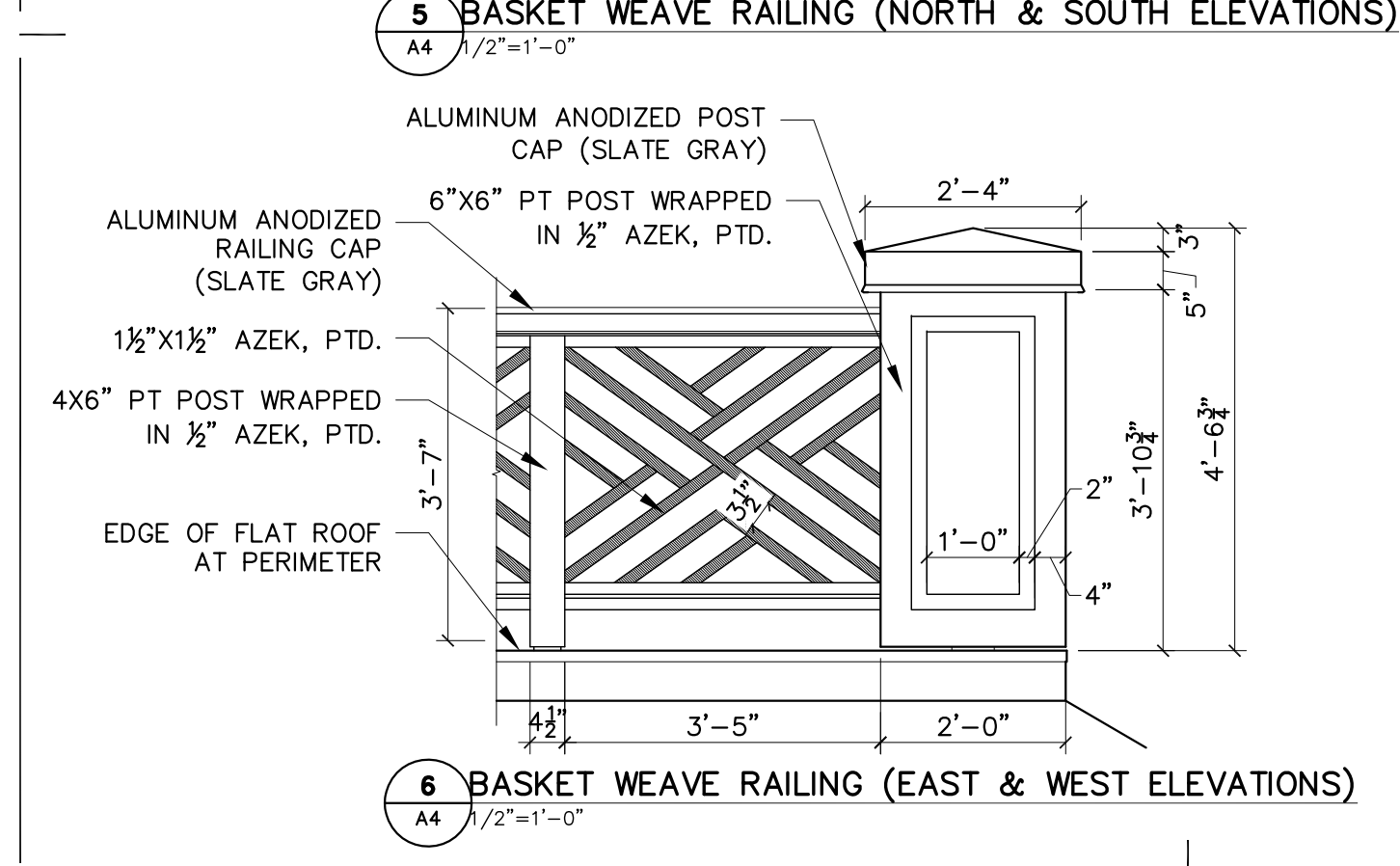

**6 BASKET WEAVE RAILING (EAST & WEST ELEVATIONS)**  
A4 SCALE: 1/2"=1'-0"

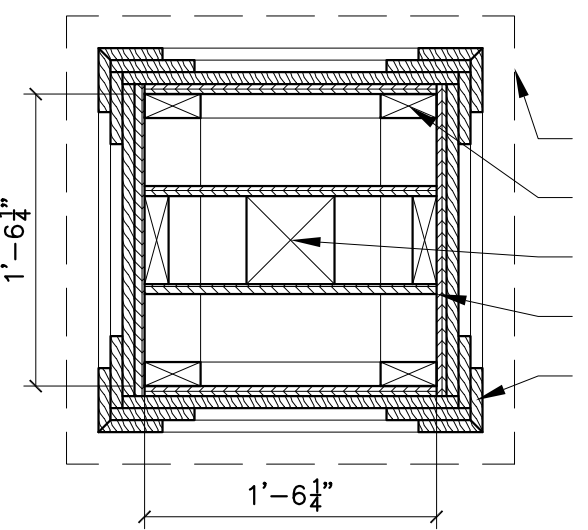

**7 TYPICAL POST PLAN**  
A4 SCALE: 1"=1'-0"

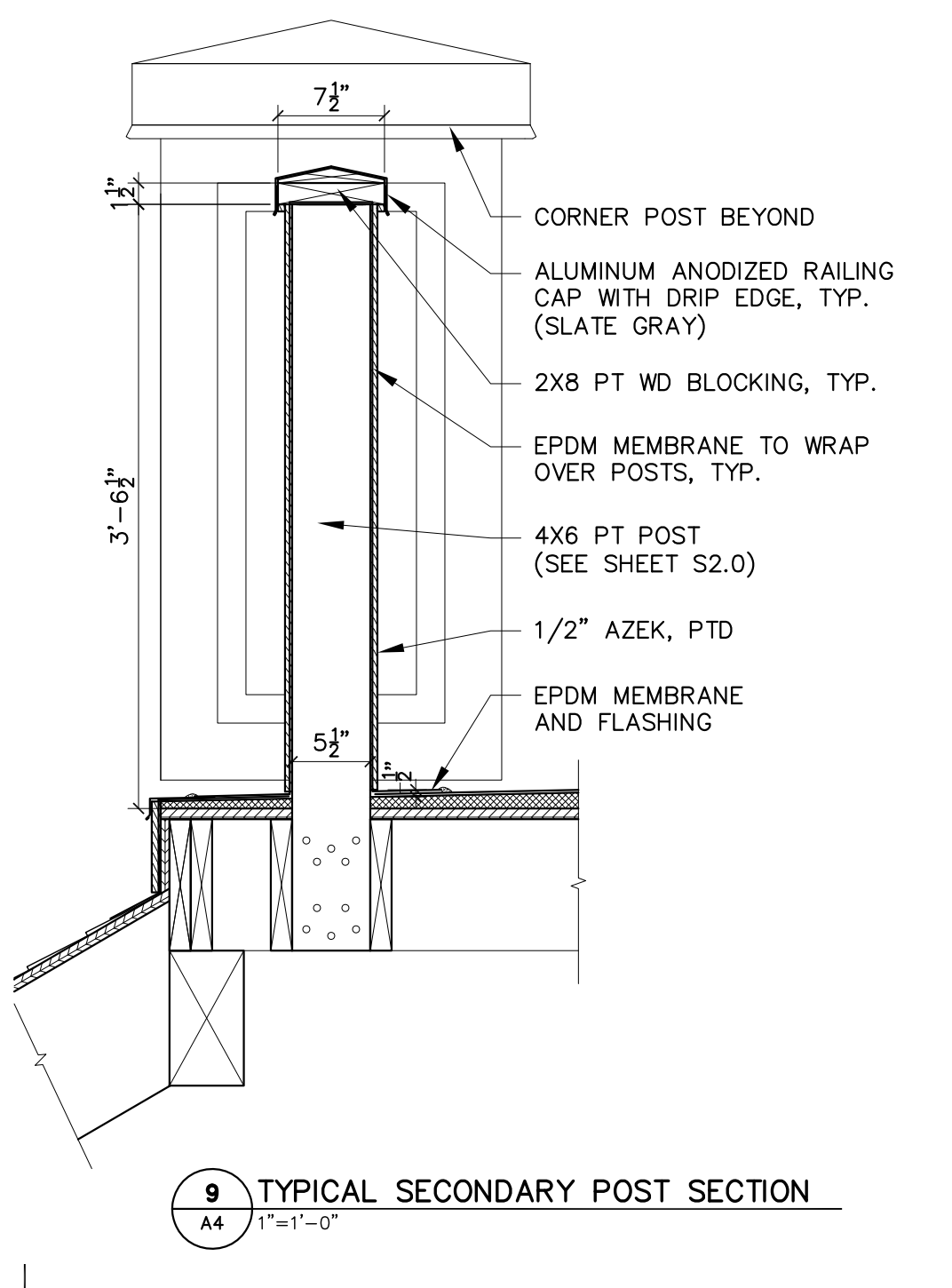

**9 TYPICAL SECONDARY POST SECTION**  
A4 SCALE: 1"=1'-0"

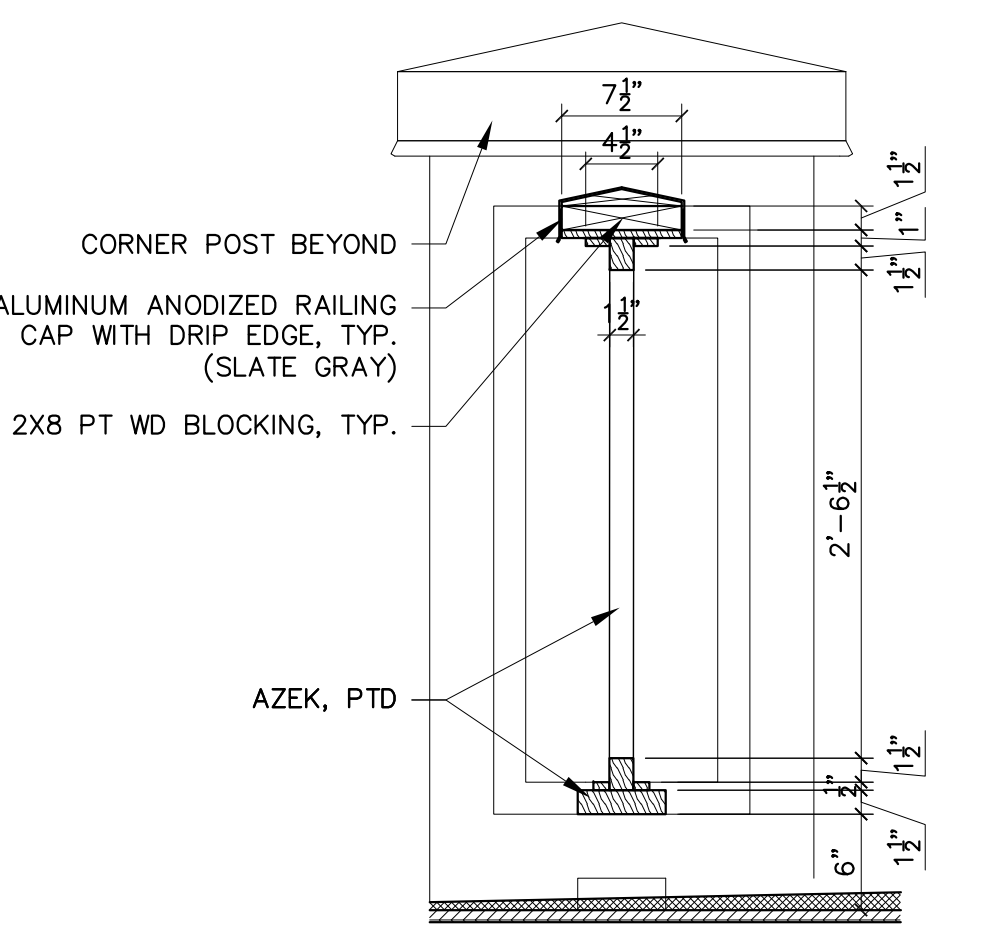

**10 TYPICAL RAILING SECTION**  
A4 SCALE: 1"=1'-0"

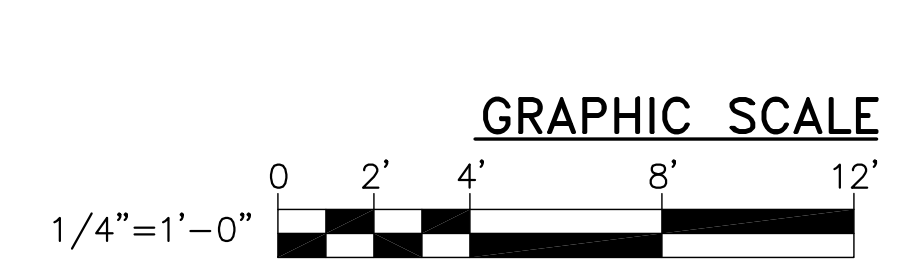

PROJECT:  
KEY:

**McHENRY ARCHITECTURE**  
4 Market Street  
Portsmouth, New Hampshire  
603.430.0274

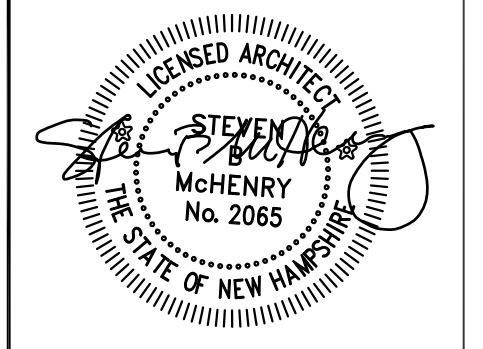

REVISIONS:

BID SET

PROJECT NAME: Prescott Park Pavilion Building  
Portsmouth, NH  
PROJECT NO.: 10014  
DRAWN BY: JH  
APPROVED BY: SMcH  
ISSUE DATE: 16SEPT2013  
DRAWING NAME:

ELEVATIONS

SCALE: 1/4"=1'-0"

DRAWING NO.: A4

SHEET NO.: 1 of X

© 2013 McHenry Architecture



**Prescott Park  
Pavilion Building**  
Portsmouth, NH

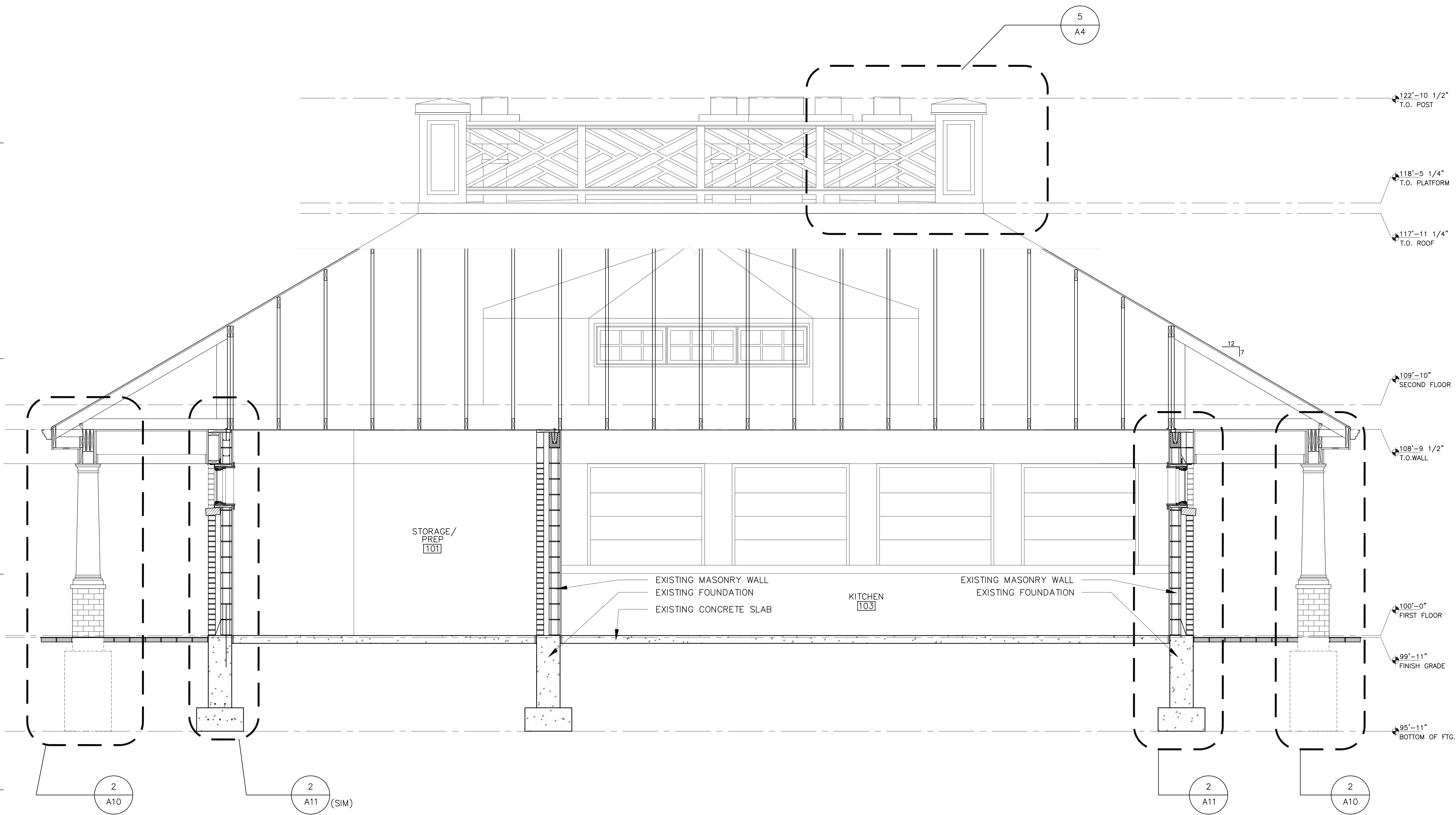

**1 BUILDING SECTION**  
A5 SCALE: 1/2"=1'-0"

PROJECT:  
KEY:

**McHENRY  
ARCHITECTURE**  
4 Market Street  
Portsmouth, New Hampshire  
603.430.0274

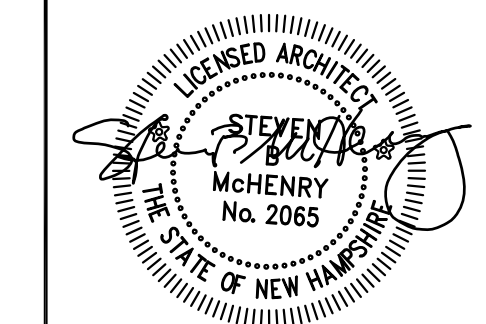

REVISIONS:  
BID SET

PROJECT NAME: Prescott Park Pavilion Building Portsmouth, NH  
PROJECT NO.: 10014  
DRAWN BY: JU  
APPROVED BY: SMcH  
ISSUE DATE: 16SEPT2013  
DRAWING NAME:

**BUILDING  
SECTIONS**

SCALE: 1/2" = 1'-0"  
DRAWING NO.:

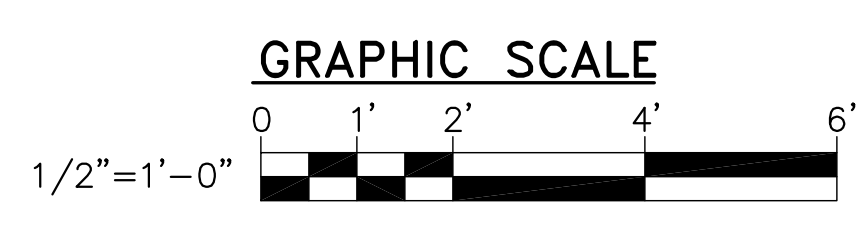

**A5**

**Prescott Park  
Pavilion Building**  
Portsmouth, NH

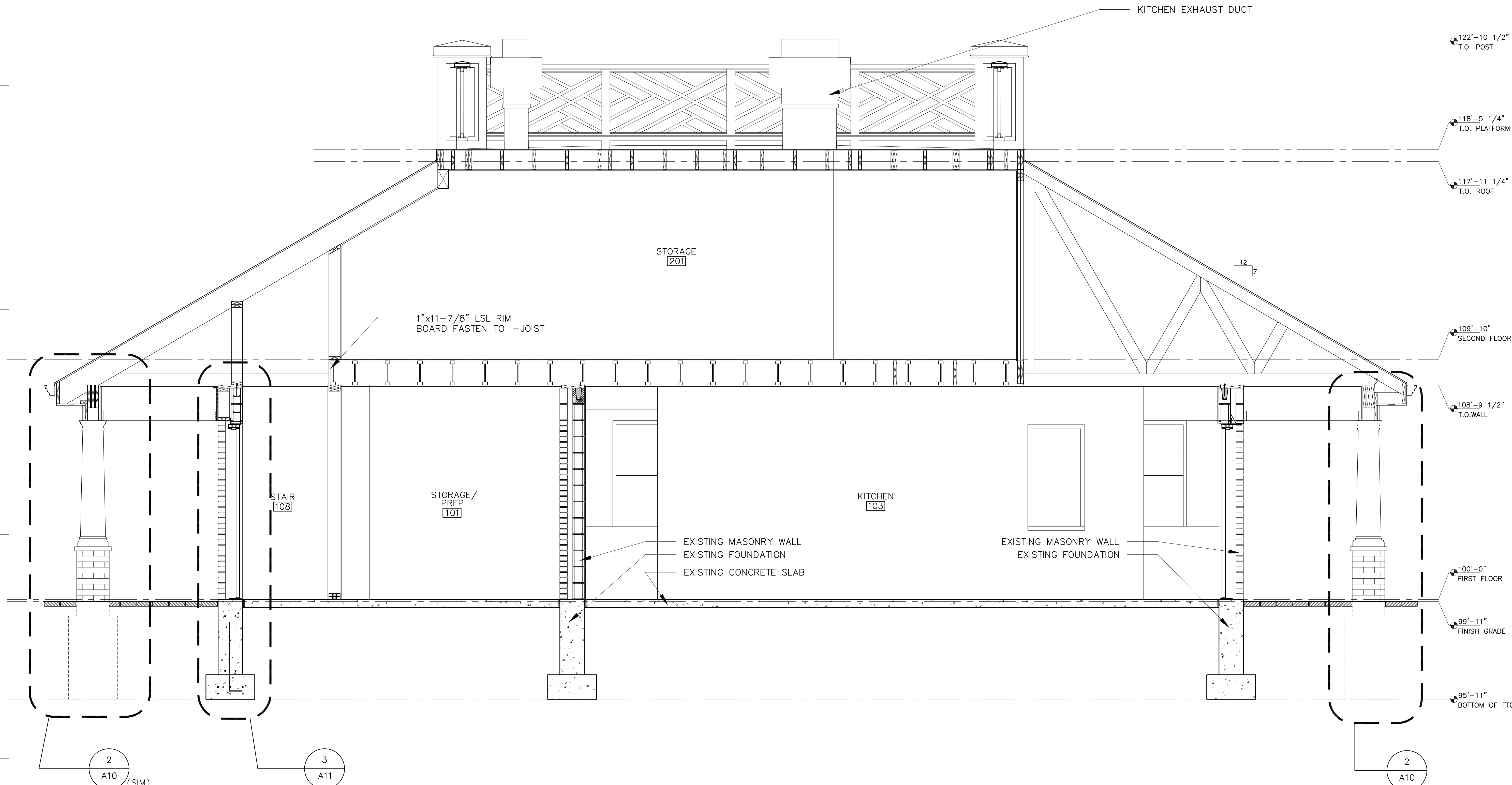

PROJECT:  
KEY:

**McHENRY  
ARCHITECTURE**  
4 Market Street  
Portsmouth, New Hampshire  
603.430.0274

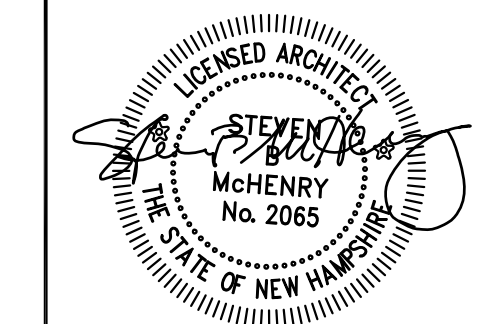

REVISIONS:  
**BID SET**

PROJECT NAME: Prescott Park Pavilion Building Portsmouth, NH  
PROJECT NO.: 10014  
DRAWN BY: JU  
APPROVED BY: SMcH  
ISSUE DATE: 16SEPT2013  
DRAWING NAME:

**BUILDING  
SECTIONS**

SCALE: 1/2" = 1'-0"  
DRAWING NO.:

**A6**

SHEET NO.: 1 of X

**2 BUILDING SECTION**  
A6 SCALE: 1/2"=1'-0"

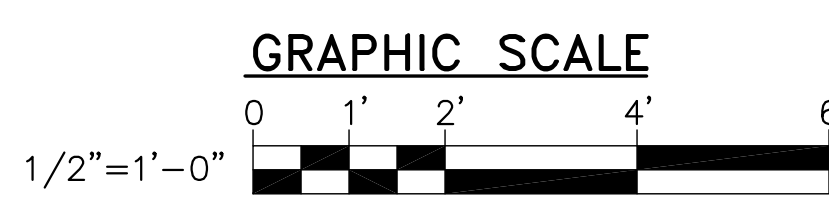

**Prescott Park  
Pavilion Building**  
Portsmouth, NH

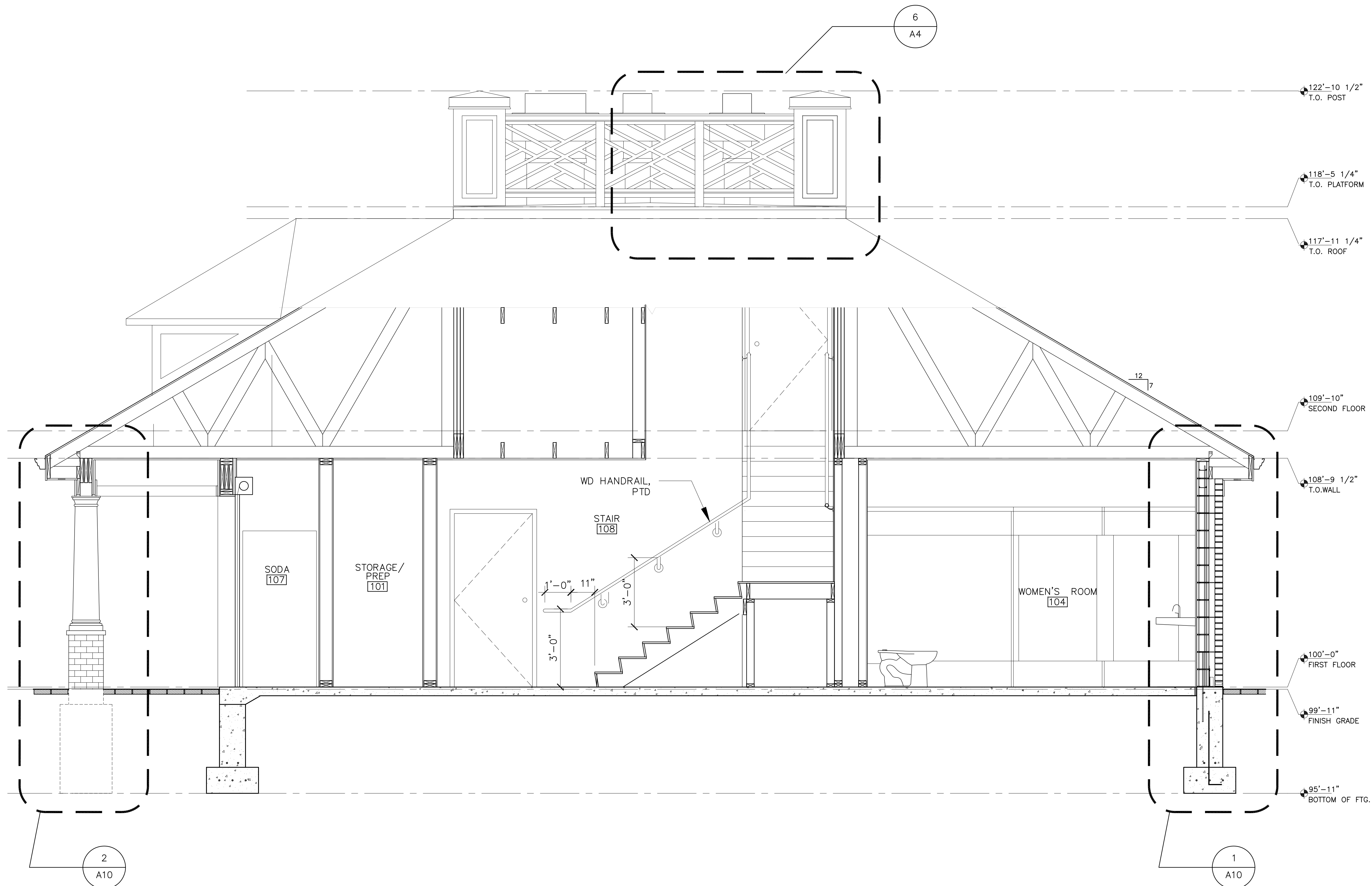

**3 BUILDING SECTION**  
A7 SCALE: 1/2"=1'-0"

PROJECT:  
KEY:

**McHENRY  
ARCHITECTURE**

4 Market Street  
Portsmouth, New Hampshire  
603.430.0274

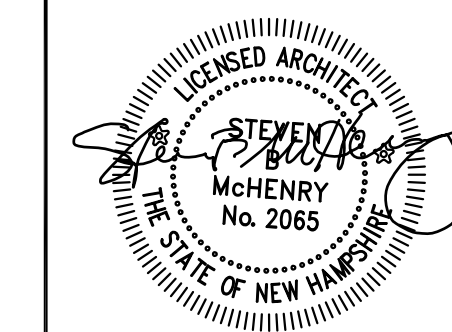

REVISIONS:  
**BID SET**

PROJECT NAME:  
Prescott Park  
Pavilion Building  
Portsmouth, NH

PROJECT NO.: 10014  
DRAWN BY: JU  
APPROVED BY: SMcH  
ISSUE DATE: 16SEPT2013  
DRAWING NAME:

**BUILDING  
SECTIONS**

SCALE: 1/2" = 1'-0"  
DRAWING NO.:

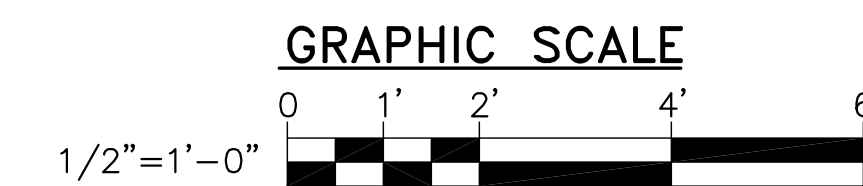

**A7**

**Prescott Park  
Pavilion Building**  
Portsmouth, NH

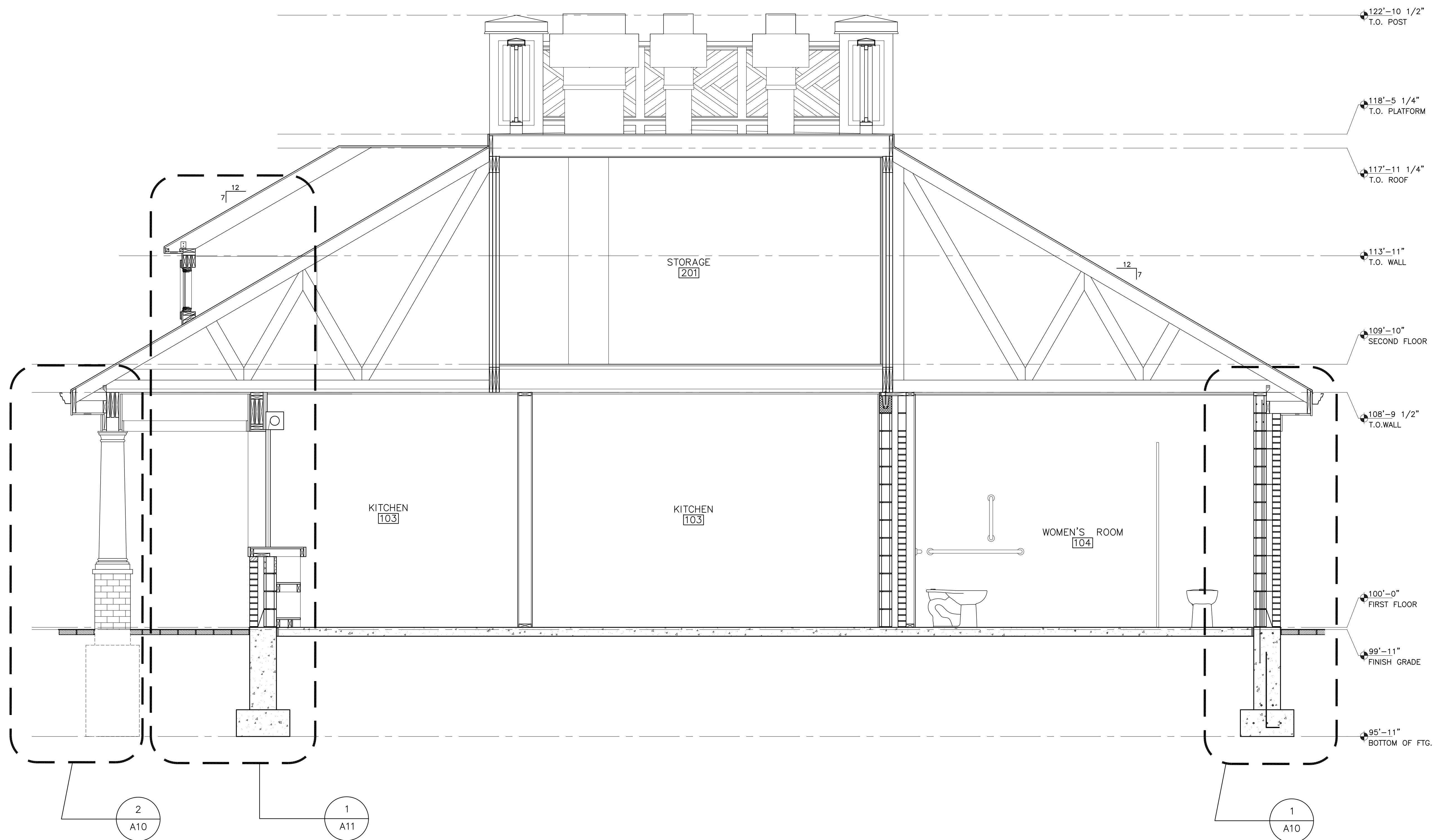

PROJECT:  
KEY:

**McHENRY  
ARCHITECTURE**  
4 Market Street  
Portsmouth, New Hampshire  
603.430.0274

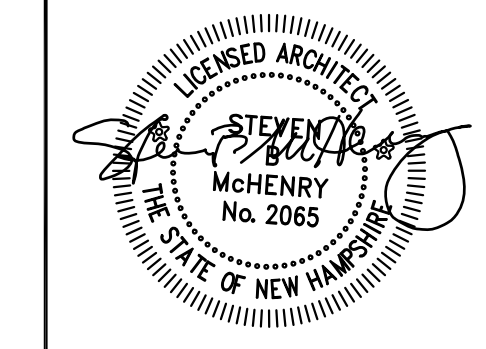

REVISIONS:  
**BID SET**

PROJECT NAME: Prescott Park Pavilion Building Portsmouth, NH  
PROJECT NO.: 10014  
DRAWN BY: JU  
APPROVED BY: SMcH  
ISSUE DATE: 16SEPT2013  
DRAWING NAME:

**BUILDING  
SECTIONS**

SCALE: 1/2"=1'-0"  
DRAWING NO.:

**A8**

SHEET NO.: 1 of X

**4 BUILDING SECTION**  
AB SCALE: 1/2"=1'-0"

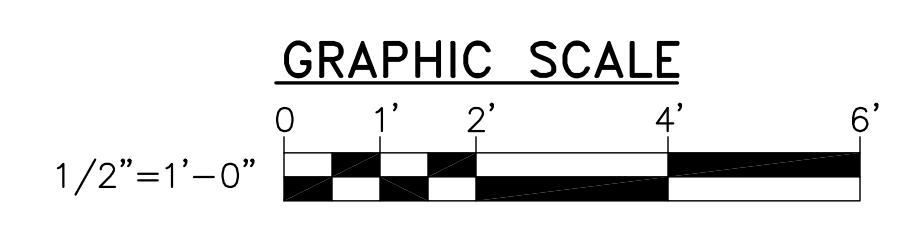

**Prescott Park  
Pavilion Building**  
Portsmouth, NH

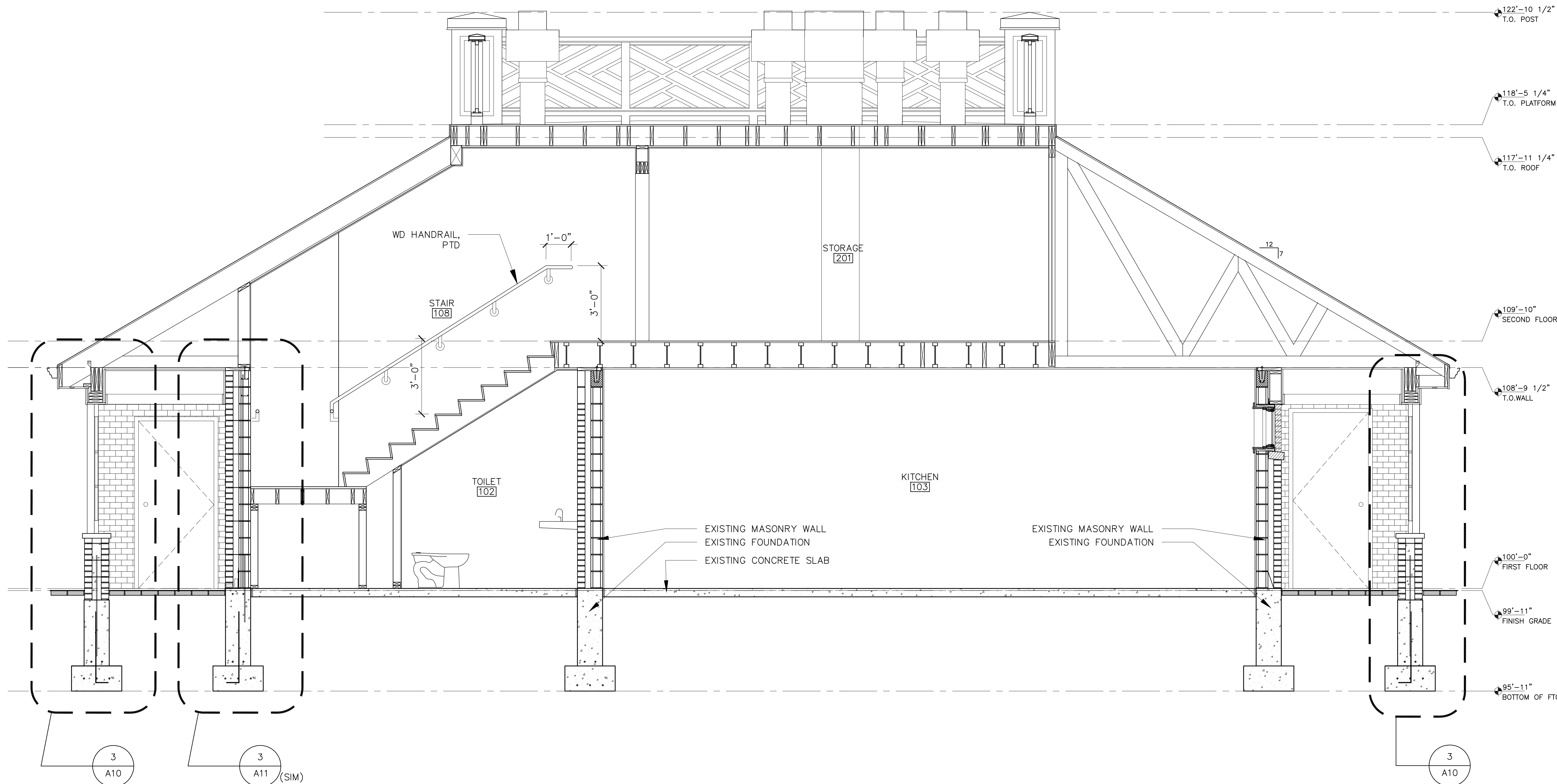

122'-10 1/2"  
T.O. POST

118'-5 1/4"  
T.O. PLATFORM

117'-11 1/4"  
T.O. ROOF

109'-10"  
SECOND FLOOR

108'-9 1/2"  
T.O. WALL

100'-0"  
FIRST FLOOR

99'-11"  
FINISH GRADE

95'-11"  
BOTTOM OF FTG.

PROJECT:  
KEY:

**McHENRY  
ARCHITECTURE**  
4 Market Street  
Portsmouth, New Hampshire  
603.430.0274

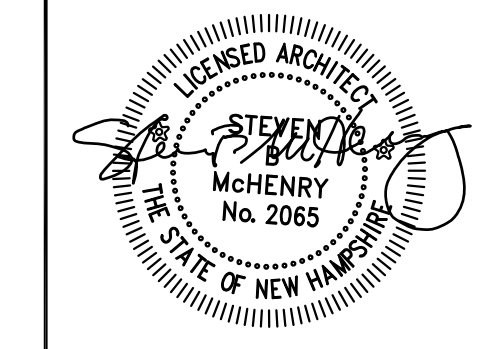

REVISIONS:  
BID SET

PROJECT NAME:  
Prescott Park  
Pavilion Building  
Portsmouth, NH

PROJECT NO.: 10014  
DRAWN BY: JU  
APPROVED BY: SMcH  
ISSUE DATE: 16SEPT2013  
DRAWING NAME:

**BUILDING  
SECTIONS**

SCALE: 1/2" = 1'-0"  
DRAWING NO.:

**A9**

SHEET NO.: 1 of X

**5 BUILDING SECTION**  
A9 SCALE: 1/2"=1'-0"

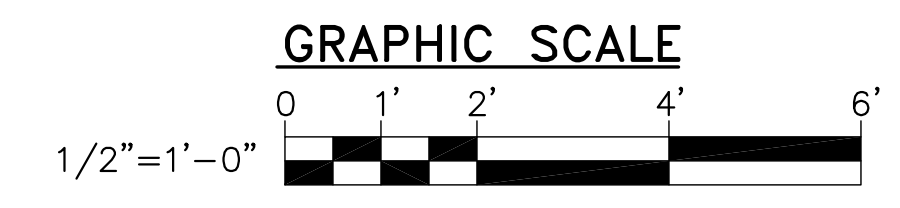

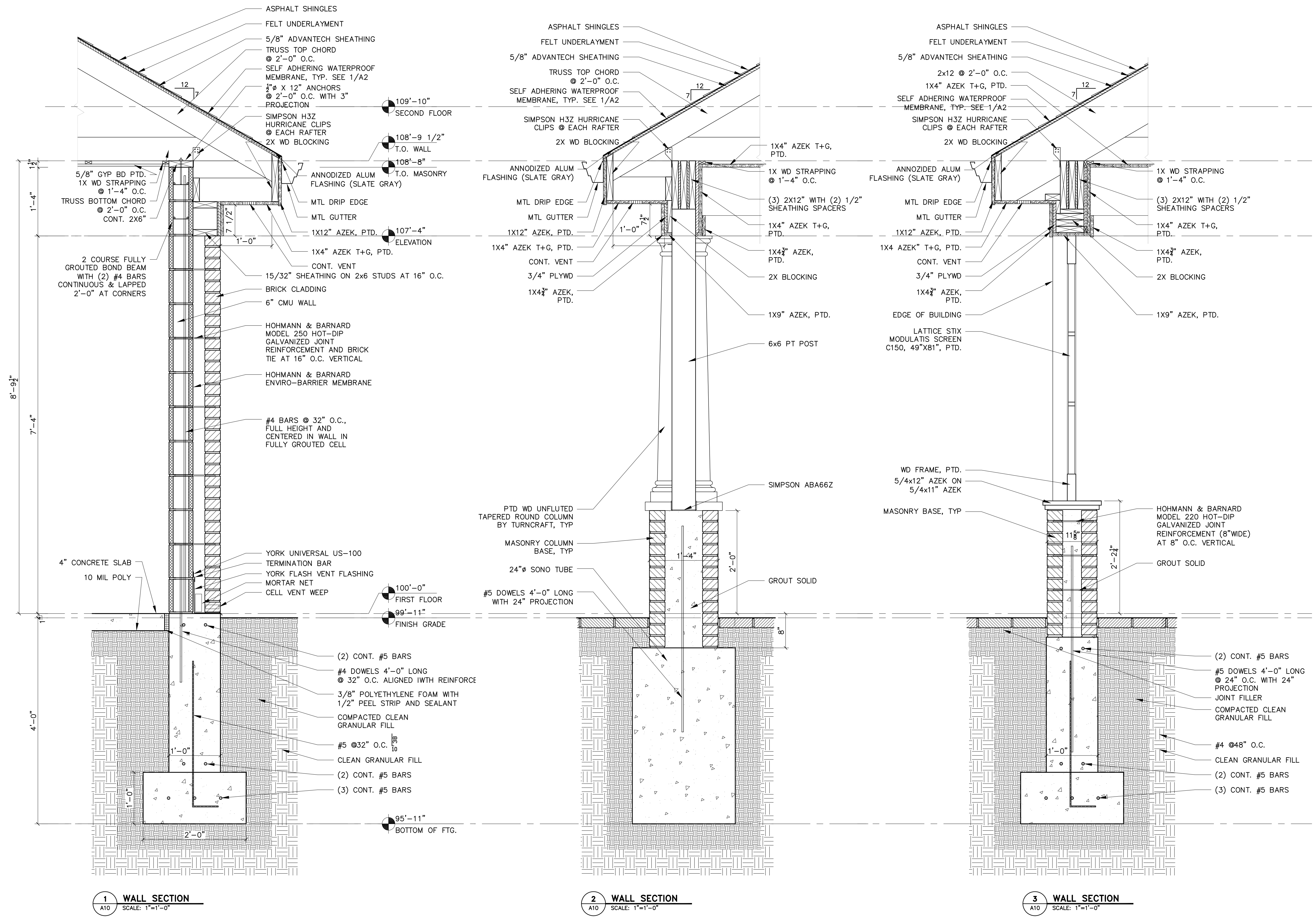

PROJECT:  
KEY:

McHENRY  
ARCHITECTURE  
4 Market Street  
Portsmouth, New Hampshire  
603.430.0274

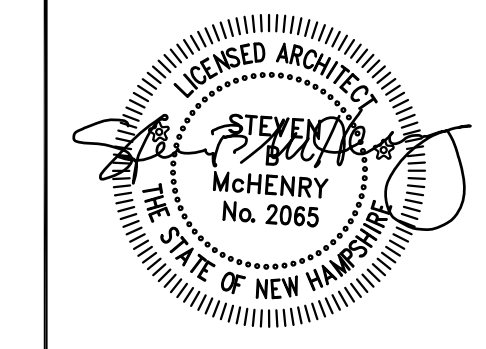

REVISIONS:  
BID SET

PROJECT NAME:  
Prescott Park  
Pavilion Building  
Portsmouth, NH

PROJECT NO.: 10014  
DRAWN BY: JU  
APPROVED BY: SMcH  
ISSUE DATE: 16SEPT2013  
DRAWING NAME:

WALL  
SECTIONS

SCALE: 1"=1'-0"

DRAWING NO.:  
**A10**

SHEET NO.: 1 of X

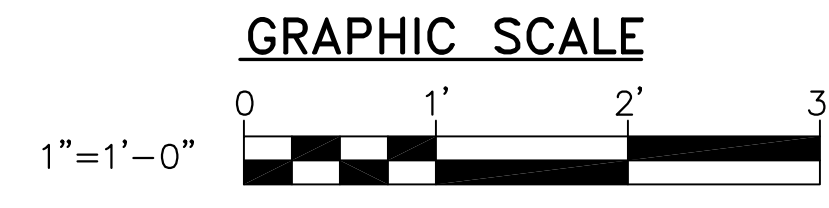

**Prescott Park Pavilion Building**  
Portsmouth, NH

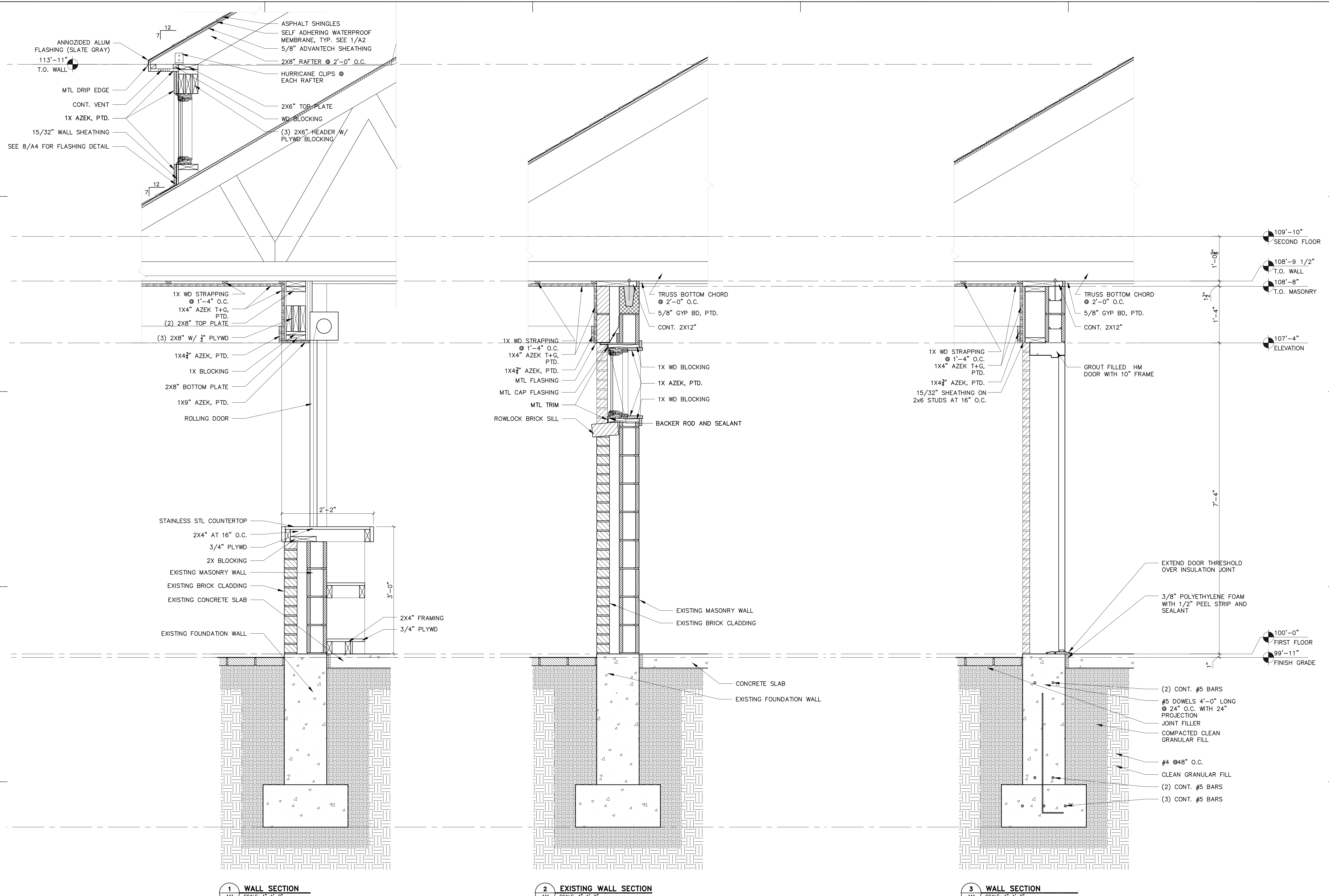

**1 WALL SECTION**  
SCALE: 1"=1'-0"

**2 EXISTING WALL SECTION**  
SCALE: 1"=1'-0"

**3 WALL SECTION**  
SCALE: 1"=1'-0"

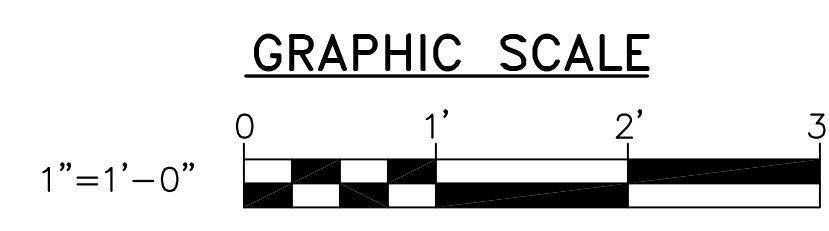

PROJECT:  
KEY:

**McHENRY ARCHITECTURE**  
4 Market Street  
Portsmouth, New Hampshire  
603.430.0274

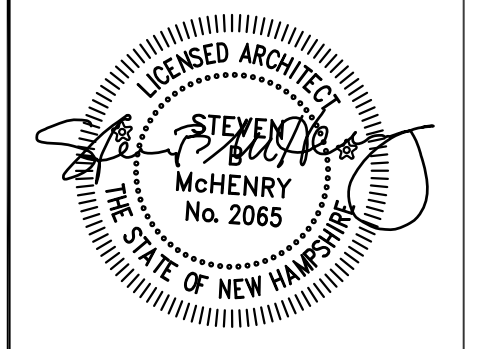

REVISIONS:  
**BID SET**

PROJECT NAME: Prescott Park Pavilion Building Portsmouth, NH  
PROJECT NO.: 10014  
DRAWN BY: JU  
APPROVED BY: SMcH  
ISSUE DATE: 16SEPT2013  
DRAWING NAME:

**WALL SECTIONS**

SCALE: 1"=1'-0"  
DRAWING NO.:

**A11**

SHEET NO.: 1 of X





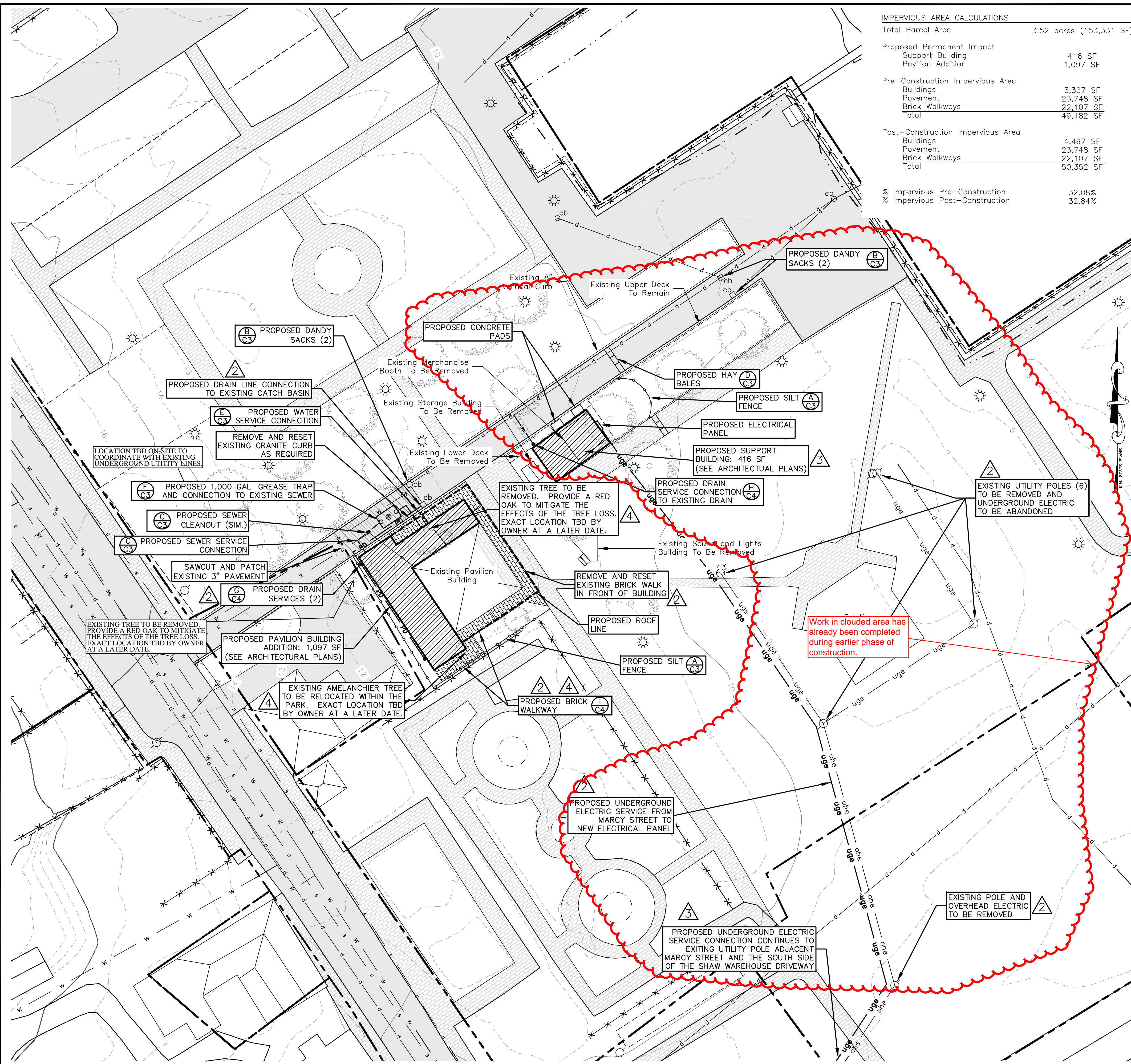

**IMPERVIOUS AREA CALCULATIONS**

Total Parcel Area	3.52 acres (153,331 SF)
Proposed Permanent Impact	
Support Building	416 SF
Pavilion Addition	1,097 SF
Pre-Construction Impervious Area	
Buildings	3,327 SF
Pavement	23,748 SF
Brick Walkways	22,107 SF
Total	49,182 SF
Post-Construction Impervious Area	
Buildings	4,497 SF
Pavement	23,748 SF
Brick Walkways	22,107 SF
Total	50,352 SF
% Impervious Pre-Construction	32.08%
% Impervious Post-Construction	32.84%

**Notes:**

- Existing conditions plan based on GIS received from the City of Portsmouth, NH in August 2011. Property lines are approximate.
- Additional features such as trees, light poles, water and sewer structures were field located by CMA Engineers, Inc. in November 2011, and are approximate.
- All underground utilities shown are approximate.
- All conditions on this Plan shall remain in effect in perpetuity pursuant to the requirements of the Site Plan Review Regulations.
- Proposed improvements require Standard Dredge and Fill Permit and Shoreland Permit from NHDES due to the projects location within the 100 foot tidal wetland buffers and 250 foot shoreland protection zones. Permit applications were filed with NHDES in November 2011. Portsmouth Conservation Commission approved the Standard Dredge and Fill permit on November 9, 2011.

**Legend:**

--- 11 ---	Existing Minor Contour
--- 10 ---	Existing Major Contour
---	Existing Property Line
---	Existing Pavement
x x x x x	Existing Fence
---	Existing Brick Walkway
- d - d - d - d - d - d -	Existing Drain Line
cb	Existing Catch Basin
s s s s s	Existing Sewer Line
o	Existing Sewer Manhole
w w w w w	Existing Water Line
ohe ohe ohe	Existing Overhead Electric
---	Existing Concrete
o	Existing Utility Pole
o	Existing Light Pole
o	Existing Tree
PD PD PD PD PD	Proposed Drain Line
---	Proposed Sewer Line
uge uge uge	Proposed Underground Electric
---	Proposed Silt Fence
---	Proposed Hay Bales
---	Proposed Building Footprint
---	Proposed Brick Walkway

**Erosion Control Notes:**

- Prior to construction and thereafter erosion control measures are to be implemented as noted. The smallest practical area of land should be exposed at any one time during development. When land is exposed during development, the exposure should be kept to the shortest practical period of time. Land should not be left exposed during the winter months.
- Catch basin inserts, Mirafi Dandy Sack or equal, shall be installed and maintained at catch basins. Sediment and debris shall be removed following each storm event.
- All disturbed areas which are finish graded with no further construction to take place shall be seeded and mulched. All disturbed areas outside limits of building and pavement shall be stabilized with loam and seed. Any disturbed areas which are to be left temporarily, or longer than two weeks and which will be regraded later during construction, shall be temporarily seeded and machine straw mulched at a rate of 1.5 tons/acre.
- Avoid use of undisturbed areas wherever possible during construction. Construction traffic shall travel the roadbeds of existing and future roads.
- Silt fences shall be minimum of 36 inches high with the bottom of the cloth keyed into the ground (see detail). Posts shall be of wood or steel. Silt fence shall be installed & maintained where shown and additional silt fence added as required by the Engineer prior to any on-site grading or disturbance of existing surface material. It should be maintained during and after development to remove sediment from runoff water and from land undergoing development. Where possible natural drainage ways should be utilized and left open to remove clean excess surface water. The silt fence is to be maintained and cleaned until all slopes have a healthy stand of grass.
- Erosion control devices shown represent minimum measures required for erosion control. The Contractor shall take any and all necessary measures to prevent transportation of sediment beyond the work area.
- After all disturbed areas have been stabilized, the temporary erosion control measures are to be removed and accumulated sediment disposed off in a location designated by the owner.
- Within the New Hampshire Department of Environmental Services Comprehensive Shoreland Protection Act 250' buffer, only low phosphate, slow release nitrogen fertilizer or limestone, may be used on lawns or areas with grass.
- All cut and fill slopes shall be seeded/loamed with 72 hours of achieving finished grade.
- All erosion controls shall be inspected weekly and after every 0.5" of rainfall.
- All areas shall be stabilized within 45 days of initial disturbance.
- All proposed vegetated areas which do not exhibit a minimum of 85% vegetative growth by October 15th, or which are disturbed after October 15th, shall be stabilized by seeding and installing erosion control blankets on slopes greater than 3:1, and seeding and placing 3 to 4 tons of mulch per acre, secured with anchored netting, elsewhere. The installation of erosion control blankets or mulch and netting shall not occur over accumulated snow or on frozen ground and shall be completed in advance of thaw or spring melt events.

date:	November 2011	designed by:	JSM/APV
project no.:	802	drawn by:	APV
file name:	802-Site Plan 130826.dwg	approved by:	WAS
scale:	1" = 20'	date:	11/14/11
scale:	1" = 20'	revision:	2
scale:	1" = 20'	revision:	3
scale:	1" = 20'	revision:	4
scale:	1" = 20'	revision:	5
scale:	1" = 20'	revision:	6
scale:	1" = 20'	revision:	7
scale:	1" = 20'	revision:	8
scale:	1" = 20'	revision:	9
scale:	1" = 20'	revision:	10
scale:	1" = 20'	revision:	11
scale:	1" = 20'	revision:	12
scale:	1" = 20'	revision:	13
scale:	1" = 20'	revision:	14
scale:	1" = 20'	revision:	15
scale:	1" = 20'	revision:	16
scale:	1" = 20'	revision:	17
scale:	1" = 20'	revision:	18
scale:	1" = 20'	revision:	19
scale:	1" = 20'	revision:	20
scale:	1" = 20'	revision:	21
scale:	1" = 20'	revision:	22
scale:	1" = 20'	revision:	23
scale:	1" = 20'	revision:	24
scale:	1" = 20'	revision:	25
scale:	1" = 20'	revision:	26
scale:	1" = 20'	revision:	27
scale:	1" = 20'	revision:	28
scale:	1" = 20'	revision:	29
scale:	1" = 20'	revision:	30
scale:	1" = 20'	revision:	31
scale:	1" = 20'	revision:	32
scale:	1" = 20'	revision:	33
scale:	1" = 20'	revision:	34
scale:	1" = 20'	revision:	35
scale:	1" = 20'	revision:	36
scale:	1" = 20'	revision:	37
scale:	1" = 20'	revision:	38
scale:	1" = 20'	revision:	39
scale:	1" = 20'	revision:	40
scale:	1" = 20'	revision:	41
scale:	1" = 20'	revision:	42
scale:	1" = 20'	revision:	43
scale:	1" = 20'	revision:	44
scale:	1" = 20'	revision:	45
scale:	1" = 20'	revision:	46
scale:	1" = 20'	revision:	47
scale:	1" = 20'	revision:	48
scale:	1" = 20'	revision:	49
scale:	1" = 20'	revision:	50
scale:	1" = 20'	revision:	51
scale:	1" = 20'	revision:	52
scale:	1" = 20'	revision:	53
scale:	1" = 20'	revision:	54
scale:	1" = 20'	revision:	55
scale:	1" = 20'	revision:	56
scale:	1" = 20'	revision:	57
scale:	1" = 20'	revision:	58
scale:	1" = 20'	revision:	59
scale:	1" = 20'	revision:	60
scale:	1" = 20'	revision:	61
scale:	1" = 20'	revision:	62
scale:	1" = 20'	revision:	63
scale:	1" = 20'	revision:	64
scale:	1" = 20'	revision:	65
scale:	1" = 20'	revision:	66
scale:	1" = 20'	revision:	67
scale:	1" = 20'	revision:	68
scale:	1" = 20'	revision:	69
scale:	1" = 20'	revision:	70
scale:	1" = 20'	revision:	71
scale:	1" = 20'	revision:	72
scale:	1" = 20'	revision:	73
scale:	1" = 20'	revision:	74
scale:	1" = 20'	revision:	75
scale:	1" = 20'	revision:	76
scale:	1" = 20'	revision:	77
scale:	1" = 20'	revision:	78
scale:	1" = 20'	revision:	79
scale:	1" = 20'	revision:	80
scale:	1" = 20'	revision:	81
scale:	1" = 20'	revision:	82
scale:	1" = 20'	revision:	83
scale:	1" = 20'	revision:	84
scale:	1" = 20'	revision:	85
scale:	1" = 20'	revision:	86
scale:	1" = 20'	revision:	87
scale:	1" = 20'	revision:	88
scale:	1" = 20'	revision:	89
scale:	1" = 20'	revision:	90
scale:	1" = 20'	revision:	91
scale:	1" = 20'	revision:	92
scale:	1" = 20'	revision:	93
scale:	1" = 20'	revision:	94
scale:	1" = 20'	revision:	95
scale:	1" = 20'	revision:	96
scale:	1" = 20'	revision:	97
scale:	1" = 20'	revision:	98
scale:	1" = 20'	revision:	99
scale:	1" = 20'	revision:	100

GENERAL

- ALL WORK SHALL CONFORM TO THE REQUIREMENTS OF ALL APPLICABLE STATE AND LOCAL CODES, INCLUDING BUT NOT LIMITED TO:
  - 2009 INTERNATIONAL BUILDING CODE
  - ANSI/ASCE 7-05
  - ACI 318-05 "BUILDING CODE REQUIREMENTS FOR REINFORCED CONCRETE"
  - ACI 301 "SPECIFICATIONS FOR STRUCTURAL CONCRETE FOR BUILDINGS"
  - ANSI/AF&PA NDS-2005
  - ACI 530-05 "BUILDING CODE REQUIREMENTS FOR MASONRY STRUCTURES"
- ANY DISCREPANCIES BETWEEN THE ABOVE LISTED CODES AND THE CONSTRUCTION DOCUMENTS SHALL BE BROUGHT TO THE ATTENTION OF THE ARCHITECT FOR CLARIFICATION BEFORE PROCEEDING WITH AFFECTED WORK.
- ALL WORK SHALL BE PERFORMED BY PERSONS QUALIFIED IN THEIR TRADE AND LICENSED TO PRACTICE SUCH TRADE IN THE STATE OF NEW HAMPSHIRE.
- THESE DRAWINGS SHALL BE USED IN CONJUNCTION WITH ANY ARCHITECTURAL, MECHANICAL, AND ELECTRICAL DRAWINGS IN ADDITION TO SPECIFICATIONS AND ANY SHOP DRAWINGS PROVIDED BY SUBCONTRACTORS AND SUPPLIERS.
- ALL DIMENSIONS, ELEVATIONS, AND CONDITIONS SHALL BE VERIFIED IN THE FIELD BY THE GENERAL CONTRACTOR (G.C.) AND ANY DISCREPANCIES SHALL BE BROUGHT TO THE ATTENTION OF THE ENGINEER FOR CLARIFICATION BEFORE PROCEEDING WITH THE AFFECTED PART OF WORK.
- DETAILS, SECTIONS, AND NOTES SHOWN ON THESE DRAWINGS SHALL BE CONSIDERED TYPICAL FOR ALL SIMILAR DETAILS.
- THESE DRAWINGS DO NOT SHOW SIZE, LOCATION, OR TYPE OF OPENINGS IN THE FOUNDATION SYSTEM FOR ELECTRICAL, PLUMBING, OR MECHANICAL EQUIPMENT. THE GENERAL CONTRACTOR SHALL BE RESPONSIBLE FOR LOCATING THESE ITEMS.
- ALL SHOP DRAWINGS PROVIDED BY OTHERS SHALL BE SUBMITTED TO THE ARCHITECT FOR REVIEW PRIOR TO THE FABRICATION OF MATERIAL OR THE PURCHASE OF NON-RETURNABLE STOCK. QUANTITY AND DIMENSIONAL REVIEW IS THE CONTRACTOR'S RESPONSIBILITY.
- TEMPORARY BRACING OR SHORING NEEDED TO HOLD THE STRUCTURE IN A SAFE AND STABLE POSITION UNTIL THE BUILDING IS COMPLETE, IS SOLELY THE RESPONSIBILITY OF THE CONTRACTOR. CONSULT INDEPENDENT ENGINEER IF DESIGN ASSISTANCE OR REVIEW IS NEEDED.
- THE BUILDING PERMIT APPLICANT (e.g. OWNER) MUST PROVIDE SPECIAL INSPECTIONS PER THE REQUIREMENTS OF CHAPTER 17 OF THE 2009 INTERNATIONAL BUILDING CODE AND FURNISH INSPECTION REPORTS TO THE CODE OFFICIAL AND TO THE ENGINEER OF RECORD. THE TESTING/INSPECTION AGENCY(S) MUST BE APPROVED BY THE ENGINEER OF RECORD. A SCHEDULE OF SPECIAL INSPECTIONS SHALL BE SUBMITTED TO ENGINEER FOR REVIEW AND APPROVAL, OR PROVIDED BY ENGINEER UPON REQUEST.

DESIGN LOADS

- THE STRUCTURE IS DESIGNED IN ACCORDANCE WITH THE 2009 IBC TO CARRY ALL THE DEAD LOADS OF THE VARIOUS STRUCTURAL, ARCHITECTURAL, MECHANICAL, AND OTHER SYSTEMS AND THE FOLLOWING MINIMUM LIVE LOADS:

FLOOR LIVE LOAD

FIRST FLOOR  
STORES, RETAIL = 100 PSF

SECOND FLOOR  
LIGHT STORAGE = 125 PSF (AT CLIENT REQUEST)

STAIRS = 100 PSF

SNOW  
GROUND SNOW LOAD, Pg = 50 PSF  
Ce = 1.0  
Ct = 1.2 (UNHEATED)  
Is = 1.0

FLAT ROOF SNOW LOAD, Pf = 42 PSF

SEE ROOF TRUSS NOTES FOR TRUSS DESIGN LOADS.

WIND  
BASIC WIND SPEED, V = 100 MPH  
Iw = 1.0  
EXPOSURE CATEGORY = C  
COMPONENTS AND CLADDING WALL PRESSURE = 23.0 PSF AT ZONE 4  
27.0 PSF AT ZONE 5

SEISMIC  
Ie = 1.0  
SITE CLASS = D  
SDS = 0.389  
SD1 = 0.138  
SEISMIC DESIGN CATEGORY = C  
SEISMIC-FORCE RESISTING SYSTEM = ORDINARY REINFORCED MASONRY SHEAR WALLS  
RESPONSE MODIFICATION FACTOR, R = 1.5  
ANALYSIS PROCEDURE = EQUIVALENT LATERAL FORCE PROCEDURE

SOIL BEARING

- FOOTINGS SHALL BEAR ON UNDISTURBED SOIL OR STRUCTURAL FILL. THE UNDERLYING SOILS AND THE STRUCTURAL FILL SHALL HAVE A MINIMUM SAFE LOAD BEARING CAPACITY OF 3000 PSF.
- REMOVE ALL EXISTING TOPSOIL, PAVEMENT, ORGANIC MATERIALS, OR OTHER SOIL THAT APPEAR TO BE UNSUITABLE PRIOR TO PREPARING THE FOOTING GRADE.
- IF ADVERSE SOIL CONDITIONS ARE ENCOUNTERED WHICH EXTEND BELOW FOOTING LEVEL, SUCH AS THOSE LISTED ABOVE, CONTACT THE ENGINEER IMMEDIATELY FOR DETERMINATION OF HOW TO REMEDY THE CONDITION BEFORE CONTINUATION OF THE WORK.
- NO FOOTINGS SHALL BE PLACED IN WATER OR ON FROZEN GROUND. ALL EXTERIOR CONSTRUCTION SHALL BE CARRIED DOWN TO A MINIMUM OF FOUR (4) FEET BELOW FINISHED, ADJACENT EXTERIOR GRADE.
- AN ALLOWABLE SOIL BEARING CAPACITY OF 3000 PSF HAS BEEN ASSUMED FOR THIS PROJECT. THE BUILDING OWNER AND CONTRACTOR ASSUME RESPONSIBILITY TO ENSURE THIS SOIL BEARING CAPACITY IF A GEOTECHNICAL ENGINEER IS NOT RETAINED TO EVALUATE SOIL CONDITIONS.

REINFORCING STEEL

- ALL REINFORCING SHALL BE DEFORMED BARS CONFORMING TO ASTM A615 GRADE 60.
- ALL REINFORCING SHALL BE DETAILED IN ACCORDANCE WITH THE LATEST ACI DETAILING MANUAL.
- WHERE CONTINUOUS BARS ARE CALLED FOR, INDICATED, REQUIRED, THEY SHALL RUN CONTINUOUSLY AROUND CORNERS, LAPPED AT NECESSARY SPLICES, SPLICES STAGGERED AND HOOKED AT DISCONTINUOUS ENDS. LAP LENGTHS SHALL BE AS SHOWN OR NOTED ON THE DRAWINGS. IF LAP/SPLICE LENGTHS ARE NOT INDICATED FOLLOW ACI STANDARDS.
- WELDED WIRE FABRIC REINFORCEMENT SHALL CONFORM TO THE REQUIREMENTS OF ASTM A185. USE FLAT SHEETS ONLY.

CAST-IN-PLACE-CONCRETE

- ALL WORK SHALL CONFORM TO "BUILDING CODE REQUIREMENTS FOR REINFORCED CONCRETE" (ACI 318-05) AND "SPECIFICATIONS FOR STRUCTURAL CONCRETE FOR BUILDINGS" (ACI 301)
- ALL FOOTINGS ARE TO REST ON UNDISTURBED SOIL OR CLEAN GRANULAR FILL COMPACTED IN LAYERS OF 12" OR LESS TO 95% COMPACTION.
- MINIMUM CONCRETE PROTECTION FOR REINFORCING STEEL SHALL BE AS FOLLOWS: CONCRETE CAST AGAINST EARTH: 3 INCHES FORMED CONCRETE EXPOSED TO EARTH OR WEATHER: 1-1/2 INCHES FOR #5 BARS AND SMALLER 2 INCHES FOR #6 BARS AND GREATER
- CALCIUM CHLORIDE IS PROHIBITED IN ANY CONCRETE MIX.
- CONCRETE SHALL BE ADEQUATELY PROTECTED FROM HOT OR COLD WEATHER AS REQUIRED BY ACI PUBLICATIONS 305 AND 306, RESPECTIVELY.
- ALL CONCRETE SHALL ATTAIN A MINIMUM ULTIMATE COMPRESSIVE STRENGTH OF 3000 PSI AT 28 DAYS.
- ALL CONCRETE SHALL BE CURED BY AN APPROVED METHOD AS PRESCRIBED BY ACI.
- MAXIMUM WATER TO CEMENT RATIO SHALL BE 0.5 WITH MID-RANGE WATER REDUCERS (MRWR) USED. W/C RATIO FOR 3000 PSI CONCRETE IN FOOTINGS MAY BE 0.53 WITHOUT THE USE OF MID-RANGE WATER REDUCERS. MINIMUM CEMENT QUANTITY SHALL BE 517 LB./YD.
- MAXIMUM CONCRETE SLUMP SHALL BE FOUR INCHES WITHOUT MRWR AND 6 INCHES WITH MRWR. MRWR MUST BE USED IN ALL CONCRETE EXCEPT FOOTINGS.
- PROVIDE CONTROL JOINTS IN CONCRETE FOUNDATION WALLS AT A MAXIMUM SPACING OF 40- FEET.

WOOD FRAMING

- ALL FRAMING SHALL BE SPRUCE-PINE-FIR, NO. 2 OR BETTER, UNLESS NOTED OTHERWISE.
- ALL TWO (2) INCH NOMINAL LUMBER SHALL BE SEASONED TO 19% MAXIMUM MOISTURE CONTENT.
- ALL LUMBER AND SHEATHING SHALL BE GRADE-STAMPED BY THE APPROPRIATE MANUFACTURER'S ASSOCIATION FOR THE APPROPRIATE USE.
- ALL WOOD IN CONTACT WITH CONCRETE, MASONRY, OR EARTH SHALL BE PRESSURE TREATED SOUTHERN PINE.
- ALL WOOD FRAMING SHALL BE BUILT PLUMB, LEVEL, SQUARE, AND TRUE WITH ADEQUATE BRACING AND CONNECTION HARDWARE TO ENSURE A RIGID STRUCTURE.
- FRAMING CONNECTIONS SHALL BE ACCURATELY CUT AND TIGHTLY FITTED AS NECESSITATED BY THE CONDITIONS ENCOUNTERED TO PROVIDE FULL SURFACE CONTACT WITHOUT USE OF SHIMS.
- INTERIOR BEARING WALL DOOR HEADER SHALL BE (3)2X10 WITH (2) 1/2" THICK SHEATHING SPACERS. SUPPORT ENDS OF HEADER ON A (1)2X6 JACK STUD.
- FLOOR SHEATHING SHALL BE 2 3/8" APA-RATED, STURD-I-FLOOR, EXPOSURE-1. GLUE AND FASTEN FLOOR SHEATHING TO FRAMING WITH 8d NAILS SPACED AT: 6" ON CENTER ALONG SUPPORTED PANEL EDGES. 12" ON CENTER ALONG INTERMEDIATE SUPPORTS.
- SLOPED ROOF SHEATHING SHALL BE 1 9/32" APA-RATED, 40/20, EXPOSURE-1, ADVANTECH OR APPROVED EQUAL. FASTEN ROOF SHEATHING TO ROOF FRAMING WITH 8d NAILS SPACED AT: 6" ON CENTER ALONG SUPPORTED PANEL EDGES. 12" ON CENTER ALONG INTERMEDIATE SUPPORTS.
- FLAT ROOF SHEATHING SHALL BE 2 3/8" APA-RATED, STURD-I-FLOOR, EXPOSURE-1. FASTEN ROOF SHEATHING TO FLAT ROOF FRAMING WITH 8d NAILS SPACED AT: 6" ON CENTER ALONG SUPPORTED PANEL EDGES. 12" ON CENTER ALONG INTERMEDIATE SUPPORTS.
- EXTERIOR WALL SHEATHING SHALL BE 1 5/8" APA-RATED, 32/16, EXPOSURE-1. FASTEN WALL SHEATHING TO WALL FRAMING WITH 8d NAILS SPACED AT: 6" ON CENTER ALONG SUPPORTED PANEL EDGES. 12" ON CENTER ALONG INTERMEDIATE SUPPORTS.

- ALL SHEATHING SHALL BE LAID WITH LONG DIMENSIONS PERPENDICULAR TO SUPPORTS AND BE CONTINUOUS OVER TWO OR MORE SUPPORTS. STAGGER ALL JOINTS.
- SHEATHING PANEL EDGES SHALL BE ADEQUATELY SPACED AT JOINTS (1/8" TYP) AS RECOMMENDED BY THE APA FOR EXPANSION. PROVIDE H-CLIPS AT ROOF SHEATHING PANEL EDGES CENTERED BETWEEN FRAMING. IF T&G SHEATHING IS NOT PROVIDED.
- SIMPSON CONSTRUCTION HARDWARE (OR APPROVED EQUAL) SHALL BE FASTENED ACCORDING TO THE MANUFACTURER'S SPECIFICATIONS AND NAILING SCHEDULE. THE GENERAL CONTRACTOR MUST BE FAMILIAR WITH, AND HAVE THE APPROPRIATE PRODUCT CATALOGS ON SITE.
  - ALL SPECIFIED FASTENERS MUST BE INSTALLED ACCORDING TO THE INSTRUCTIONS IN THE SIMPSON CATALOG. INCORRECT FASTENER QUANTITY, SIZE, TYPE, MATERIAL, OR FINISH MAY CAUSE THE CONNECTION TO FAIL.
  - PNEUMATIC NAILERS MAY BE USED TO INSTALL CONNECTORS, PROVIDED THE CORRECT QUANTITY AND TYPE OF NAILS ARE PROPERLY INSTALLED IN THE NAIL HOLES. TOOLS WITH NAIL HOLE-LOCATING MECHANISMS SHOULD BE USED. FOLLOW THE MANUFACTURER'S INSTRUCTIONS AND USE THE APPROPRIATE SAFETY EQUIPMENT.
  - JOIST SHALL BEAR COMPLETELY ON THE CONNECTOR SEAT AND THE GAP BETWEEN THE JOIST AND THE HEADER SHALL NOT EXCEED 1/8".
- MINIMUM FASTENING OF WOOD MEMBERS SHALL CONFORM TO TABLE 2304.9.1 OF THE 2009 IBC.
- BEAMS NOTED AS "VL" SHALL BE "VERSA-LAM" AS MANUFACTURED BY BOISE CASCADE (E=2,000,000 PSI, Fb=3080 PSI). VERSA-LAM PRODUCTS SHALL BE PROPERLY STORED AND PROTECTED FROM WATER DAMAGE DURING CONSTRUCTION.
- COLUMNS NOTED AS "VL" SHALL BE "VERSA-LAM" AS MANUFACTURED BY BOISE CASCADE (E=1,800,000 PSI, Fb=2200 PSI). VERSA-LAM PRODUCTS SHALL BE PROPERLY STORED AND PROTECTED FROM WATER DAMAGE DURING CONSTRUCTION.
- POSTS NOTED AS PT SHALL BE SOUTHERN PINE GRADE #2, Fb=1,500 PSI, Fv=175 PSI, E=1,600,000

PRESSURE TREATED LUMBER

- PRESSURE TREATED LUMBER SHALL BE TREATED WITH AN ACO PROCESS SUITABLE TO EXTERIOR EXPOSED SERVICE. **DO NOT ALLOW ACO TREATMENT WITH AMMONIA.**
- USE PT SOUTHERN PINE LUMBER FOR ALL EXTERIOR FRAMING AND FOR SILL PLATES ON FOUNDATION WALLS, MASONRY WALLS, AND INTERIOR SLABS ON GRADE.
- USE G185 GALVANIZED CONNECTORS WITH HOT-DIP GALVANIZED FASTENERS, AS SPECIFIED ON THE DRAWINGS, FOR ALL EXTERIOR CONSTRUCTION.
- FAILURE TO FOLLOW THESE NOTES MAY RESULT IN A RAPID CORROSION OF METAL FASTENERS AND CONNECTORS AND STRUCTURAL FAILURE.

CONCRETE BLOCK MASONRY UNIT CONSTRUCTION

- CONCRETE MASONRY UNIT (CMU) CONSTRUCTION SHALL CONFORM TO "BUILDING CODE REQUIREMENTS FOR MASONRY STRUCTURES" (ACI 530-08 / ASCE 5-08 / TMS 402-08).
- REINFORCED MASONRY SHALL CONSIST OF MASONRY UNITS, MORTAR BETWEEN UNITS, GROUT IN CELLS, LINTELS, BOND BEAMS, HORIZONTAL JOINT REINFORCING, AND STEEL REINFORCING IN VERTICAL CELLS, BOND BEAMS AND LINTELS.
- CONCRETE MASONRY UNITS SHALL CONFORM TO ASTM C90 AND SHALL HAVE A MINIMUM NET AREA COMPRESSIVE STRENGTH OF 1900 PSI. CERTIFICATION OF UNIT STRENGTH SHALL BE PROVIDED BY MANUFACTURER.
- GROUT SHALL BE CONCRETE WITH A MINIMUM 28-DAY COMPRESSIVE STRENGTH (F'c) OF 2000 PSI, WITH A MAXIMUM COARSE AGGREGATE SIZE OF 3/8", SLUMP AT POINT OF PLACEMENT OF 8 TO 11 INCHES, AND DESIGNED FOR PUMPING. GROUT SHALL CONFORM TO ASTM C476 "SPECIFICATION FOR MORTAR AND GROUT FOR MASONRY."
- THE MINIMUM COMPRESSIVE STRENGTH OF CMU CONSTRUCTION (F'M) SHALL BE 1500 PSI AND SHALL BE DETERMINED USING THE UNIT STRENGTH METHOD PER ACI 530-08/ASCE 5-08/TMS 402-08 SECTION 1.4.
- MORTAR FOR REINFORCED MASONRY SHALL MEET THE APPLICABLE REQUIREMENTS OF ASTM SPECIFICATION C270, TYPE S.
- GROUT AND MORTAR SHALL BE KEPT ENTIRELY SEPARATE, AND SHALL NOT BE USED INTERCHANGEABLY.
- PROVIDE HOHMANN & BARNARD MODEL 250 HOT-DIP GALVANIZED LADDER-MESH HORIZONTAL JOINT REINFORCEMENT SPACED AT 16" ON CENTER VERTICALLY (EVERY OTHER COURSE), CONFORMING TO ANSI/ASTM A82, WITH 9-GAGE SIDE RODS AND CROSS TIES. JOINT REINFORCEMENT SHALL BE CONTINUOUS WITH SECTIONS LAPPED 6" MINIMUM, EXCEPT AT CONTROL JOINTS WHERE JOINT REINFORCING SHALL TERMINATE.
- TYPICAL VERTICAL REINFORCING SHALL BE #5 BARS AT 32" ON CENTER, UNLESS NOTED OTHERWISE ON PLANS. VERTICAL REINFORCING SHALL BE PLACED AT EACH JAMB OF EACH WALL OPENING AND AT EACH CORNER AND WALL INTERSECTION.
- PLACE REINFORCEMENT AND TIES IN GROUT SPACES PRIOR TO GROUTING (PER ACI 530.1 SECTION 3.2E). THIS IS REQUIRED IN ORDER TO AVOID LOSS OF BOND AND MISALIGNMENT OF REINFORCING BARS.
- VERTICAL REINFORCING SHALL BE CONTINUOUS AND SHALL LAP A MINIMUM OF 48 BAR DIAMETERS, (30" FOR #5 BARS). BARS SHALL BE SUPPORTED BY WIRE POSITIONERS AS REQUIRED TO MAINTAIN PROPER POSITION IN CELL.
- CELLS ARE TO BE GROUTED USING LOW-LIFT GROUTING PROCEDURES. CELLS SHALL BE FILLED TO DEPTH OF 4' AND RODDED OR VIBRATED, PERMITTED TO REST FOR A PERIOD OF 30-60 MINUTES, AN ADDITIONAL 4" DEPTH FILLED, AND AGAIN RODDED OR VIBRATED. SECOND VIBRATING SHALL EXTEND AT LEAST 12" INTO PREVIOUSLY GROUTED LAYER. GROUT SHALL BE PUMPED INTO PLACE. GROUT LEVEL AT EACH LIFT SHALL STOP MIN 1/2" BELOW TOP OF CMU TO FORM A KEYWAY.
- MORTAR PLASTICITY SHALL BE MAINTAINED BY RE-TEMPERING AS REQUIRED UP TO 2-1/2 HOURS AFTER ORIGINAL MIXING. MORTAR REQUIRING RE-TEMPERING AFTER THAT PERIOD SHALL BE DISCARDED.
- GROUT SHALL NOT BE RE-TEMPERED, BUT SHALL BE DISCARDED IMMEDIATELY IF PLASTICITY IS LOST BEFORE GROUT IS PLACED IN WALL. GROUT SHALL BE USED WITHIN 1-1/2 HOURS OF INITIAL MIXING.
- COLD OR HOT WEATHER MASONRY CONSTRUCTION SHALL CONFORM TO THE ACI 530-08/ASCE 5-08/TMS 402-08 SECTION 1.8 AND ACI 305 AND 306, RESPECTIVELY.
- METAL LATH SHALL BE USED UNDER BOND BEAMS TO CONFINE GROUT FROM HOLLOW CORES.
- PROCEDURES OF NCM-A-TEK #3-3A SHALL BE FOLLOWED FOR ALL REINFORCED MASONRY CONCRETE CONSTRUCTION.
- LAY ALL CONCRETE MASONRY UNITS IN RUNNING BOND.
- INSPECTION OF MASONRY CONSTRUCTION SHALL BE PERFORMED AS REQUIRED BY IBC 2009 CHAPTER 17.
- LOCATE CONTROL JOINTS IN CMU WALLS AT A MAXIMUM SPACING OF 20- FEET. PROVIDE A SASH BLOCK ON EACH SIDE OF JOINT WITH REINFORCED AND GROUTED CELLS, A PREFORMED GASKET BETWEEN THE SASH BLOCKS AND BACKER ROD AND SEALANT ON EACH FACE OF WALL.
- ALONG THE TOP OF THE MASONRY WALL PROVIDE 1/2" X 10" LONG HOT DIP GALVANIZED ANCHOR BOLTS WITH 3" PROJECTION. SPACE ANCHOR BOLTS AT 2- FEET O.C. MAXIMUM.

BRICK MASONRY UNIT CONSTRUCTION

- MASONRY CONSTRUCTION SHALL CONFORM TO "BUILDING CODE REQUIREMENTS FOR MASONRY STRUCTURES" (ACI 530-08 / ASCE 5-08 / TMS 402-08).
- BRICK MASONRY UNITS SHALL HAVE A MINIMUM NET AREA COMPRESSIVE ALLOWABLE STRENGTH OF 500 PSI.
- MORTAR SHALL MEET THE APPLICABLE REQUIREMENTS OF ASTM SPECIFICATION C270, TYPE N.
- SEE CONCRETE BLOCK MASONRY UNIT NOTES FOR ADDITIONAL INFORMATION.
- LOCATE EXPANSION JOINTS IN MASONRY VENEER WALLS AS SHOWN ON THE DRAWINGS AND AT A MAXIMUM SPACING OF 20- FEET. RAKE THE VERTICAL JOINT CLEAN AND PROVIDE A BACKER ROD AND SEALANT.

MASONRY VENEER LOOSE LINTEL SCHEDULE

- AT MASONRY VENEER OPENINGS PROVIDE AN ANGLE, PLACED WITH LONG LEG VERTICAL, IN ACCORDANCE WITH THE FOLLOWING SCHEDULE:

MAXIMUM OPENING	LINTEL
UP TO 3'-5"	L3-1/2 X 3-1/2 X 3/8"
3'-6" TO 4'-6"	L4 X 3-1/2 X 3/8"
4'-7" TO 6'-0"	L5 X 3-1/2 X 3/8"
6'-1" TO 8'-0"	L6 X 3-1/2 X 3/8"
8'-1" TO 11'-0"	L7 X 4 X 3/8"

- ALL LINTELS SHALL BE HOT DIP GALVANIZED.
- LINTELS SHALL BE 8" LONGER THAN MASONRY OPENING AND SHALL HAVE A MINIMUM OF 4" BEARING ON MASONRY AT EACH END.
- LINTELS SHOWN ARE FOR 4" VENEER THICKNESS ONLY.

WOOD TRUSSES

- ALL WOOD ROOF TRUSSES SHALL BE DESIGNED AND MANUFACTURED BY BOISE STRUCTURAL SOLUTIONS, INC. OF BIDDEFORD, MAINE OR APPROVED EQUAL. ALL ASSOCIATED CONNECTION HARDWARE FOR TRUSSES SHALL BE DESIGNED AND SUPPLIED BY THE TRUSS MANUFACTURER WITH THE SIZE AND QUANTITY OF FASTENERS SPECIFIED. TRUSS DESIGNS ARE TO BE STAMPED BY A REGISTERED PROFESSIONAL ENGINEER RETAINED BY MANUFACTURER. CALCULATIONS AND SHOP DRAWINGS SHALL BE SUBMITTED TO THE ENGINEER FOR REVIEW AND APPROVAL PRIOR TO START OF PRODUCTION.
- ALL WOOD TRUSSES SHALL BE BRACED IN ACCORDANCE WITH THE MANUFACTURER'S REQUIREMENTS AND IN ACCORDANCE WITH TRUSS PLATE INSTITUTE (TPI) PUBLICATION BCSI 2013 FOR BRACING WOOD TRUSSES. PROPER BRACING OF WOOD TRUSSES DURING ERECTION IS THE RESPONSIBILITY OF THE GENERAL CONTRACTOR.
- MINIMUM GRADE FOR ANY TRUSS MEMBER SHALL BE #2.
- WOOD TRUSS MANUFACTURER SHALL CLEARLY LABEL ALL COMPRESSION WEBS WHICH REQUIRE LATERAL BRACING WITH RED TAGS OR PAINT.
- WOOD TRUSS MANUFACTURER SHALL MAINTAIN A MAXIMUM PANEL POINT SPACING OF 10 FT.
- ROOF TRUSSES SHALL BE DESIGNED FOR THE FOLLOWING LOADS, UNLESS NOTED OTHERWISE:
  - TOP CHORD SNOW LOAD - 50 PSF BALANCED\*
  - TOP CHORD DEAD LOAD - 7 PSF
  - BOTTOM CHORD LIVE LOAD - 10 PSF
  - BOTTOM CHORD DEAD LOAD - 7 PSF

\* CONSIDER UNBALANCED LOADING PER ASCE 7-05
- WOOD TRUSS LAYOUT DRAWINGS SHALL BE PREPARED ON 24"x36" SHEETS AND CLEARLY LABEL ALL TRUSSES AND CONNECTORS. SHOP DRAWINGS MUST INCLUDE THE FOLLOWING INFORMATION: MEMBER SPECIES AND GRADE; MEMBER FORCES; MEMBER CSI RATIOS; ACTUAL DL AND LL DEFLECTIONS; REACTIONS; CONNECTOR PLATE REQUIREMENTS AND SIZES.
- ROOF TRUSSES SHALL BE DESIGNED FOR A MAXIMUM LIVE LOAD DEFLECTION CRITERIA OF L/480.
- THE "MINIMUM" MEMBER SIZE USED IN ANY ROOF TRUSS SHALL BE A 2X4. THE MINIMUM "PLATE" SIZE USED ON ANY ROOF TRUSS CONNECTION SHALL BE 3"x4".
- ERECTION BRACING OF WOOD TRUSSES IS SOLELY THE RESPONSIBILITY OF THE CONTRACTOR. THIS IS MEANS AND METHODS. FOLLOW THE LATEST EDITION OF THE TPI PUBLICATION BCSI STRICTLY IN ADDITION TO WEB BRACING REQUIREMENTS SHOWN ON TRUSS SHOP DRAWINGS. CONSULT TRUSS MANUFACTURER OR INDEPENDENT ENGINEER IF FURTHER DESIGN ASSISTANCE IS NEEDED.
- ALL LATERAL BRACING INSTALLED ON COMPRESSION WEBS OF TRUSSES, AS DIRECTED BY MANUFACTURER, MUST HAVE CROSS BRACING INSTALLED ON SAME WEB PLANE AT INTERVALS SHOWN ON THESE DRAWINGS AND BCSI-B3 FIGURE B3-11. NOTE THAT CROSS BRACING IS REQUIRED FOR PERMANENT BRACING TO PREVENT WEBS FROM BUCKLING AS A GROUP. WHERE DIAGONAL BRACES CROSS, INTERRUPT ONE BRACE AND ADD A 4-FT. LONG 2X4 SPLICE OVER THE INTERRUPTED BRACE AND USE (8) 10d NAILS ON EACH SIDE. AS AN ALTERNATE, VEE OR CHEVRON BRACING CAN BE INSTALLED USING THE SAME QUANTITY OF DIAGONAL MEMBERS, WHICH ELIMINATES THE NEED FOR THE SPLICE. IN THE EVENT THAT TEE-BRACING OR STRONGBACKS ARE USED INSTEAD OF CONTINUOUS LATERAL BRACING, THE CROSS BRACING IS THEN ONLY A TEMPORARY ERECTION STABILITY REQUIREMENT. CONTINUOUS LATERAL BRACING MUST, HOWEVER, BE LOCATED ON TOP AND BOTTOM CHORDS ABOVE AND BELOW CROSS BRACING FOR TEMPORARY CROSS BRACING TO BE EFFECTIVE.
- TRUSS MANUFACTURER SHALL ATTEMPT TO ALIGN ADJACENT TRUSS WEBS TO ALLOW INSTALLATION OF LATERAL BRACING. A MINIMUM OF 6 ADJACENT WEBS MUST ALIGN, OTHERWISE MANUFACTURER SHALL SPECIFY AND PROVIDE A DETAIL FOR TEE-BRACING.

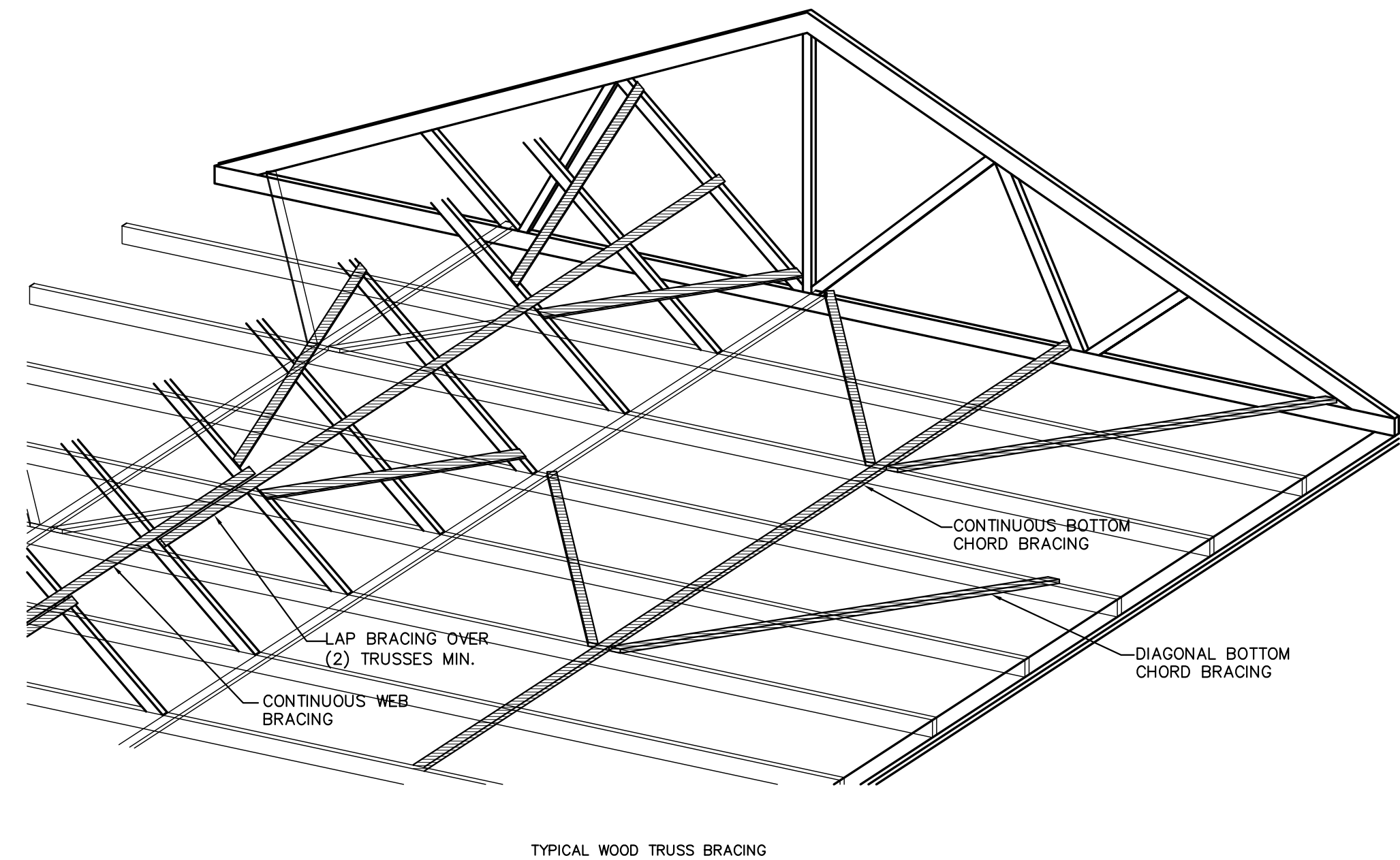
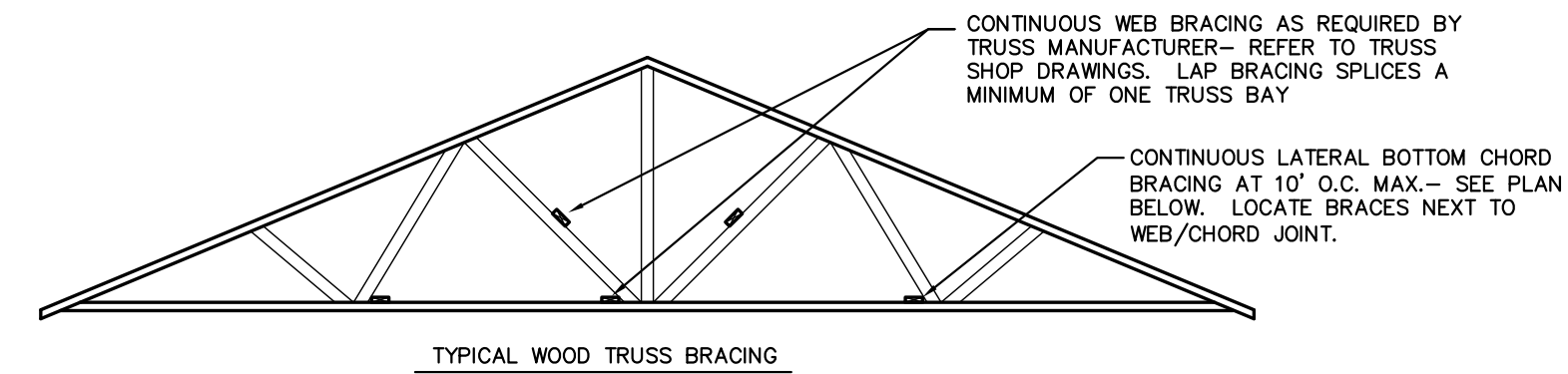

Prescott Park Pavilion Building  
Portsmouth, NH

PROJECT:

KEY:

McHENRY ARCHITECTURE

4 Market Street  
Portsmouth, New Hampshire  
603.430.0274

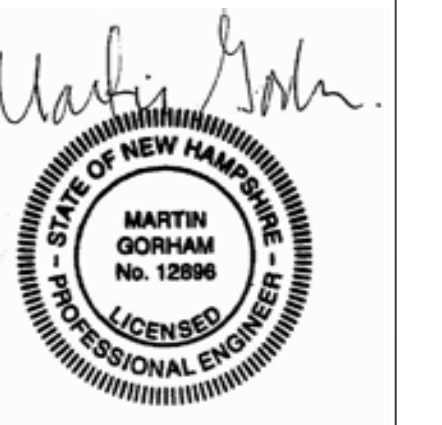

REVISIONS:

BID SET

PROJECT NAME:

Prescott Park Pavilion Building  
Portsmouth, NH

PROJECT NO.: 10014

DRAWN BY: JU

APPROVED BY: SMcH

ISSUE DATE: 16 SEPT 2013

DRAWING NAME:

GENERAL STRUCTURAL NOTES

SCALE: 1/4" = 1'-0"

DRAWING NO.:

S0.0

**SCHEDULE OF SPECIAL INSPECTIONS**

**PROJECT:** PRESOTT PARK PAVILION  
**LOCATION:** PRESOTT PARK  
 MARCY STREET  
 PORTSMOUTH, NH  
  
**OWNER:** CITY OF PORTSMOUTH  
 DEPARTMENT OF PUBLIC WORKS  
 680 PEVERLY HILL ROAD  
 PORTSMOUTH, NH 03801

THIS STATEMENT OF SPECIAL INSPECTIONS IS SUBMITTED AS A CONDITION FOR PERMIT ISSUANCE IN ACCORDANCE WITH THE SPECIAL INSPECTION REQUIREMENTS OF THE 2006 INTERNATIONAL BUILDING CODE. IT INCLUDES A SCHEDULE OF SPECIAL INSPECTION SERVICES APPLICABLE TO THIS PROJECT AS WELL AS THE NAME OF SPECIAL INSPECTORS AND THE IDENTITY OF OTHER APPROVED AGENCIES INTENDED TO BE RETAINED FOR CONDUCTING THESE SERVICES.

THE SPECIAL INSPECTOR SHALL KEEP RECORDS OF ALL INSPECTIONS AND SHALL FURNISH INSPECTION REPORTS TO THE BUILDING OFFICIAL, STRUCTURAL ENGINEER AND ARCHITECT OF RECORD. DISCOVERED DISCREPANCIES SHALL BE BROUGHT TO THE IMMEDIATE ATTENTION OF THE CONTRACTOR.

A FINAL REPORT OF SPECIAL INSPECTIONS BY THE SPECIAL INSPECTOR(S) DOCUMENTING COMPLETION OF ALL REQUIRED SPECIAL INSPECTIONS AND CORRECTION OF ANY DISCREPANCIES NOTED IN THE INSPECTIONS SHALL BE SUBMITTED PRIOR TO ISSUANCE OF A CERTIFICATE OF USE AND OCCUPANCY.

THE SPECIAL INSPECTOR, WHO IS GENERALLY EMPLOYED BY THE PRIMARY TESTING AGENCY, MAY USE VARIOUS INSPECTORS WHO ARE FAMILIAR WITH EACH CATEGORY OF WORK. IF SPECIAL INSPECTIONS ARE ALSO PERFORMED BY AGENTS WHO ARE NOT EMPLOYED BY PRIMARY TESTING AGENCY, EACH OF THESE ADDITIONAL SPECIAL INSPECTORS SHALL ISSUE A FINAL REPORT FOR THEIR CATEGORY OF INSPECTION. ONLY AFTER THE FINAL REPORT(S) HAS(HAVE) BEEN ISSUED BY THE SPECIAL INSPECTOR(S) CAN THE ARCHITECT ISSUE FINAL AFFIDAVITS FOR THE PROJECT COMPLETION.

JOB SITE SAFETY AND MEANS AND METHODS OF CONSTRUCTION ARE SOLELY THE RESPONSIBILITY OF THE CONTRACTOR.

<b>OWNER'S AUTHORIZATION:</b>	<b>BUILDING OFFICIAL'S AUTHORIZATION:</b>
_____ SIGNATURE	_____ SIGNATURE
_____ DATE	_____ DATE

**SCHEDULE OF SPECIAL INSPECTION SERVICES**

THE FOLLOWING TABLES COMPRISE THE REQUIRED SCHEDULE OF SPECIAL INSPECTIONS FOR THIS PROJECT. THE CONSTRUCTION DIVISIONS WHICH REQUIRE SPECIAL INSPECTIONS FOR THIS PROJECT ARE AS FOLLOWS:

SOILS AND FOUNDATIONS  
 CAST-IN-PLACE CONCRETE  
 WOOD CONSTRUCTION  
 STRUCTURAL STEEL

INSPECTION AGENTS	FIRM	ADDRESS
1. SPECIAL INSPECTOR	TBD	TBD
2. TESTING LABORATORY	TBD	TBD
3. DESIGN PROFESSIONAL	McHENRY ARCHITECTURE	4 MARKET STREET PORTSMOUTH, NH 03801 (603) 430-0274

NOTE: THE INSPECTION AND TESTING AGENT SHALL BE ENGAGED BY THE OWNER OR THE OWNER'S AGENT, AND NOT BY THE CONTRACTOR OR SUBCONTRACTOR WHOSE WORK IS TO BE INSPECTED OR TESTED. ANY CONFLICT OF INTEREST MUST BE DISCLOSED TO THE BUILDING OFFICIAL, PRIOR TO COMMENCING WORK.

<b>SEISMIC DESIGN CATEGORY:</b>	C
<b>BASIC WIND SPEED:</b>	100 MPH
<b>WIND EXPOSURE CATEGORY:</b>	C

**QUALIFICATIONS OF INSPECTORS AND TESTING TECHNICIANS**

THE QUALIFICATIONS OF ALL PERSONNEL PERFORMING SPECIAL INSPECTION ACTIVITIES ARE SUBJECT TO THE APPROVAL OF THE BUILDING OFFICIAL. THE CREDENTIALS OF ALL INSPECTORS AND TESTING TECHNICIANS SHALL BE PROVIDED IF REQUESTED.

IT IS RECOMMENDED THAT THE PERSON ADMINISTERING THE SPECIAL INSPECTIONS PROGRAM BE A PROFESSIONAL ENGINEER EXPERIENCED IN THE DESIGN OF BUILDINGS.

**SOILS AND FOUNDATIONS**

ITEM	AGENT NO.	SCOPE
1. SHALLOW FOUNDATIONS	1	VERIFY THAT UNSUITABLE BEARING MATERIALS ARE REMOVED. VERIFY THE SOIL LOAD-BEARING CAPACITY CONFORMS WITH THAT IDENTIFIED IN THE CONSTRUCTION DOCUMENTS.
2. CONTROLLED STRUCTURAL FILL	1	INSPECT COMPACTED FILL OPERATIONS TO VERIFY THE FILL MATERIAL, LIFT HEIGHTS, AND LEVEL OF COMPACTION ARE IN CONFORMANCE WITH THE REQUIREMENTS OF CONSTRUCTION.

**CAST-IN-PLACE CONCRETE**

ITEM	AGENT NO.	SCOPE
1. MIX DESIGN	3	REVIEW FOR COMPLIANCE WITH CONSTRUCTION DOCUMENTS.
2. MATERIAL CERTIFICATION	3	REVIEW FOR COMPLIANCE WITH CONSTRUCTION DOCUMENTS.
3. REINFORCEMENT INSTALLATION	1,3	(1) REVIEW THE INSTALLATION OF THE REINFORCING STEEL FOR COMPLIANCE WITH THE CONSTRUCTION DOCUMENTS AND THE APPROVED SHOP DRAWINGS. REVIEW FOR 25% OF FOOTINGS, SOLE OF FROST WALLS. (3) RANDOM REVIEW OF CONSTRUCTION PROCEDURE.
4. FORMWORK GEOMETRY	1	REVIEW GEOMETRY FOR COMPLIANCE WITH THE STRUCTURAL CONSTRUCTION DOCUMENTS. CONDUCT REVIEW WHEN REINFORCING STEEL INSTALLATION IS BEING REVIEWED.
5. CONCRETE PLACEMENT	1	INSPECT THE PLACEMENT OF CONCRETE FOR CONFORMANCE WITH THE CONSTRUCTION DOCUMENTS. TEST SLUMP AND TEMPERATURE OF EACH BATCH. TEST AIR CONTENT WHEN COMPRESSIVE STRENGTH TEST SPECIMENS ARE MOLDED.
6. EVALUATION OF CONCRETE STRENGTH	1	OBTAIN ONE SET OF (5) STANDARD CYLINDERS FOR EACH COMPRESSIVE STRENGTH TEST. TEST ONE SPECIMEN AT 7-DAYS, (2) AT 28-DAYS, AND RETAIN TWO IN RESERVE FOR LATER TESTING IF REQUIRED.  IN COLD WEATHER, TEST CYLINDERS SHALL BE FIELD CURED. ADDITIONAL CYLINDERS SHALL BE TAKEN AND LABORATORY CURED PER ACI REQUIREMENTS.  TESTING FREQUENCY: (1) COMPRESSIVE STRENGTH TEST SHOULD BE PERFORMED FOR EACH DAY'S POUR EXCEEDING 5 CU. YDS. AND (1) ADD'L SET FOR EACH 50 CU. YDS. MORE THAN THE FIRST 25 CU. YDS.
7. CURING AND PLACEMENT	1	VERIFY THE CONCRETE IS ADEQUATELY PROTECTED UNDER HOT AND COLD WEATHER CONDITIONS AS INDICATED IN THE CONCRETE SPECIFICATIONS. VERIFY THAT SLABS ARE CURED IN ACCORDANCE WITH ACI RECOMMENDED STANDARD PROCEDURES.

**REINFORCED CONCRETE MASONRY**

ITEM	AGENT NO.	SCOPE
1. MATERIAL CERTIFICATION	3	REVIEW CERTIFICATES OF COMPLIANCE FOR MASONRY UNITS, MORTAR MIX DESIGNS AND STRENGTH TESTS, GROUT DESIGNS AND STRENGTH TESTS, AND MANUFACTURER'S CATALOG DATA FOR JOINT REINFORCING AND METAL ACCESSORIES.
2. MIXING OF MORTAR AND GROUT	1	INSPECT THE PROPORTIONING AND MIXING OF MORTAR AND GROUT FOR CONFORMANCE WITH ACI 530.1-08, SECTION 2.1 AND 2.6, AND THE CONSTRUCTION DOCUMENTS.
3. INSTALLATION OF MASONRY	1,3	(1) INSPECT THE PLACEMENT OF MORTAR AND MASONRY UNITS FOR CONFORMANCE WITH ACI 530.1-08, SECTION 3.3, AND THE CONSTRUCTION DOCUMENTS. (3) RANDOM OBSERVATION.
4. REINFORCEMENT INSTALLATION	1,3	(1) INSPECT THE SIZE, CONDITION, LOCATION, AND PLACEMENT OF REINFORCEMENT FOR CONFORMANCE WITH THE CONSTRUCTION DOCUMENTS AND ACI 530-08, SECTION 3.4. (3) RANDOM OBSERVATIONS.
5. GROUTING OPERATIONS	1	INSPECT THE PLACEMENT OF GROUT (INCLUDING GROUT VIBRATION) FOR CONFORMANCE WITH ACI 530.1-08, SECTION 3.5 AND THE CONSTRUCTION DOCUMENTS.
6. WEATHER PROTECTION	1	INSPECT MASONRY PLACEMENT AND PROTECTION FOR CONFORMANCE WITH ACI 530.1-08, SECTION 1.8 AND THE CONSTRUCTION DOCUMENTS.
7. EVALUATION OF MASONRY STRENGTH	3	DETERMINE STRENGTH BY THE UNIT STRENGTH METHOD IN CONFORMANCE WITH ACI 530.1-08, SECTION 1.4. PROVIDE MANUFACTURER'S TEST DATA AND CERTIFICATES FOR MASONRY UNITS, GROUT, MORTAR, AND REINFORCING.
8. CONNECTIONS	1	VERIFY THAT CONNECTIONS OF THE MASONRY UNITS TO STRUCTURAL MEMBERS ARE PROVIDED WHERE INDICATED IN THE CONSTRUCTION DOCUMENTS.

**WOOD CONSTRUCTION**

ITEM	AGENT NO.	SCOPE
1. TRUSS FABRICATOR CERTIFICATION/QUALITY CONTROL PROCEDURES	3	CONFIRM THAT THE FABRICATOR MAINTAINS DETAILED FABRICATION AND QUALITY CONTROL PROCEDURES WHICH CONFORM TO THE REQUIREMENTS OF THE TRUSS PLATE INSTITUTE (TPI) AND WOOD TRUSS COUNCIL OF AMERICA (WTCA).
2. MATERIAL GRADING	3	REVIEW SPECIES AND GRADES OF LUMBER USED TO ENSURE CONFORMANCE WITH CONSTRUCTION DOCUMENTS. REVIEW TRUSS MEMBERS TO ENSURE CONFORMANCE WITH TRUSS ENGINEERING AND SHOP DRAWINGS.
3. CONNECTIONS	3	VERIFY THAT ROOF TRUSS AND OTHER WOOD FRAME CONNECTIONS COMPLY WITH CONSTRUCTION DOCUMENTS AND SHOP DRAWINGS.
4. FRAMING DETAILS	3	VERIFY THAT FRAMING CONFIGURATION AND ALIGNMENT OF WALL FRAMING BELOW FLOOR AND ROOF FRAMING IS AS SPECIFIED ON THE CONSTRUCTION DOCUMENTS. VERIFY PERMANENT TRUSS BRACING TO CONFORM WITH PROJECT REQUIREMENTS.
5. OTHER	3	VERIFY THAT FASTENING OF ALL LATERAL LOAD RESISTING ELEMENTS SUCH AS SHEAR WALLS AND DIAPHRAGMS ARE IN CONFORMANCE WITH THE CONSTRUCTION DOCUMENTS.

PROJECT:

KEY:

**McHENRY ARCHITECTURE**

4 Market Street  
Portsmouth, New Hampshire  
603.430.0274

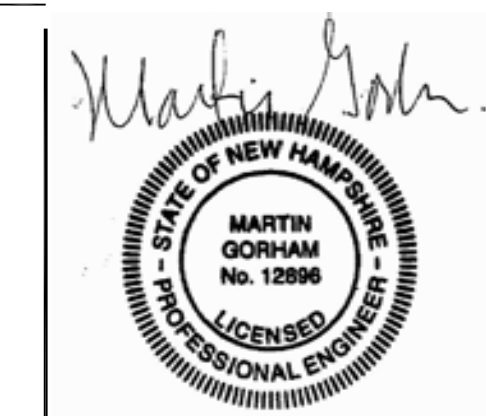

REVISIONS: **BID SET**

PROJECT NAME: Prescott Park Pavilion Building Portsmouth, NH

PROJECT NO.: 10014  
 DRAWN BY: JU  
 APPROVED BY: SMcH  
 ISSUE DATE: 16 SEPT 2013

DRAWING NAME: **SCHEDULE OF SPECIAL INSPECTIONS**

SCALE: 1/4" = 1'-0"

DRAWING NO.: **S0.1**

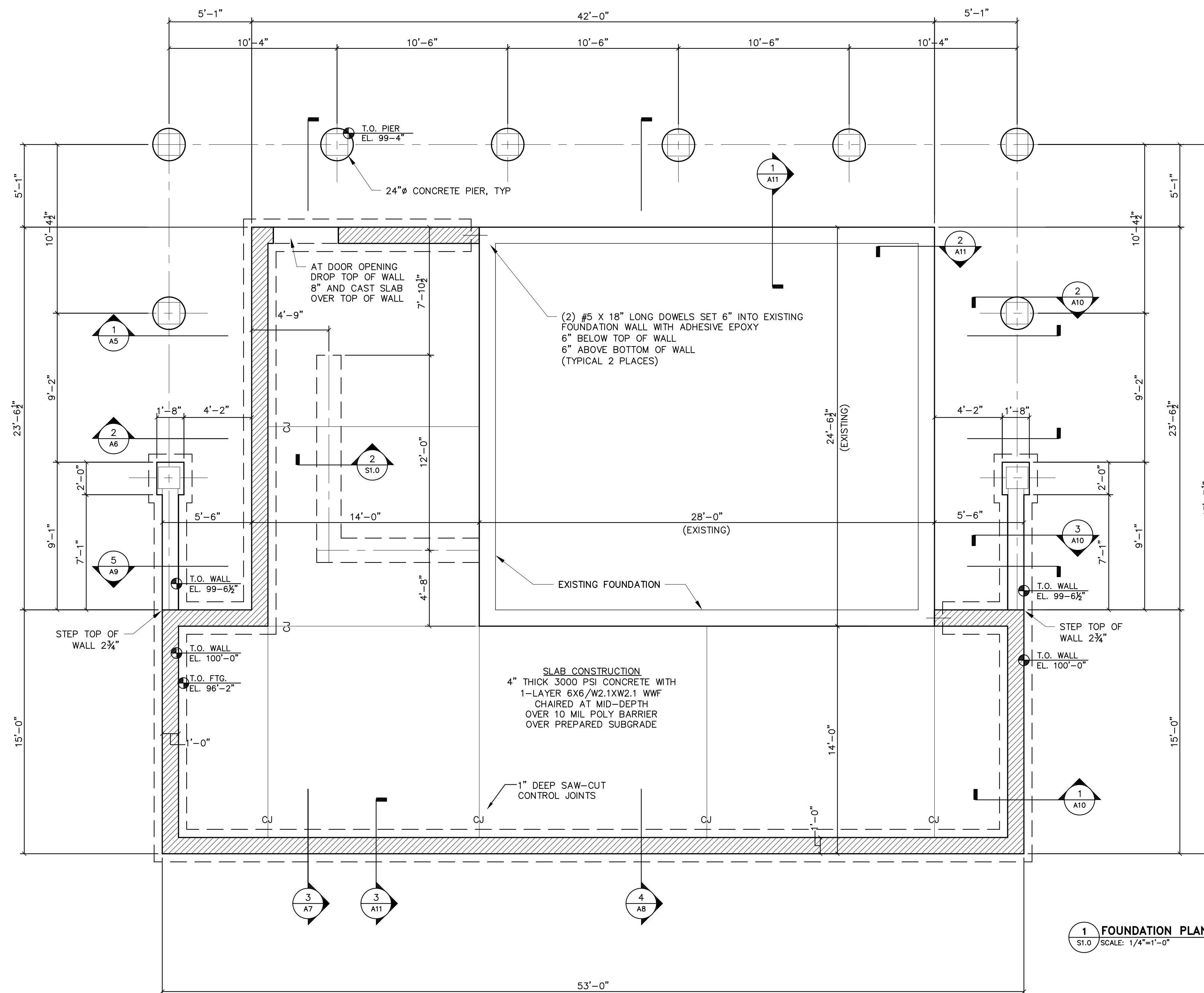

**1 FOUNDATION PLAN**  
S1.0 SCALE: 1/4"=1'-0"

- NOTES:
1. TOP OF FIRST FLOOR DATUM ELEVATION 0'-0" HAS BEEN ASSUMED. SEE CIVIL DRAWINGS FOR ACTUAL FIRST FLOOR AND EXTERIOR GRADE ELEVATIONS.
  2. SEE SHEET S0.0, FOR GENERAL NOTES.
  3. SEE ARCHITECTURAL WALL AND BUILDING SECTIONS FOR FOUNDATION DETAILS.
  4. GENERAL CONTRACTOR SHALL COORDINATE UNDERSLAB UTILITIES.
  5. FOUNDATION CONTRACTOR SHALL FINISH TOP OF FOUNDATION WALL SMOOTH AND LEVEL.
  6. BACKFILL BOTH SIDES OF FOUNDATION WALLS WITH COMPACTED STRUCTURAL FILL.
  7. SUPPORT EXTERIOR WALKWAYS ON FREE DRAINING COMPACTED STRUCTURAL FILL.

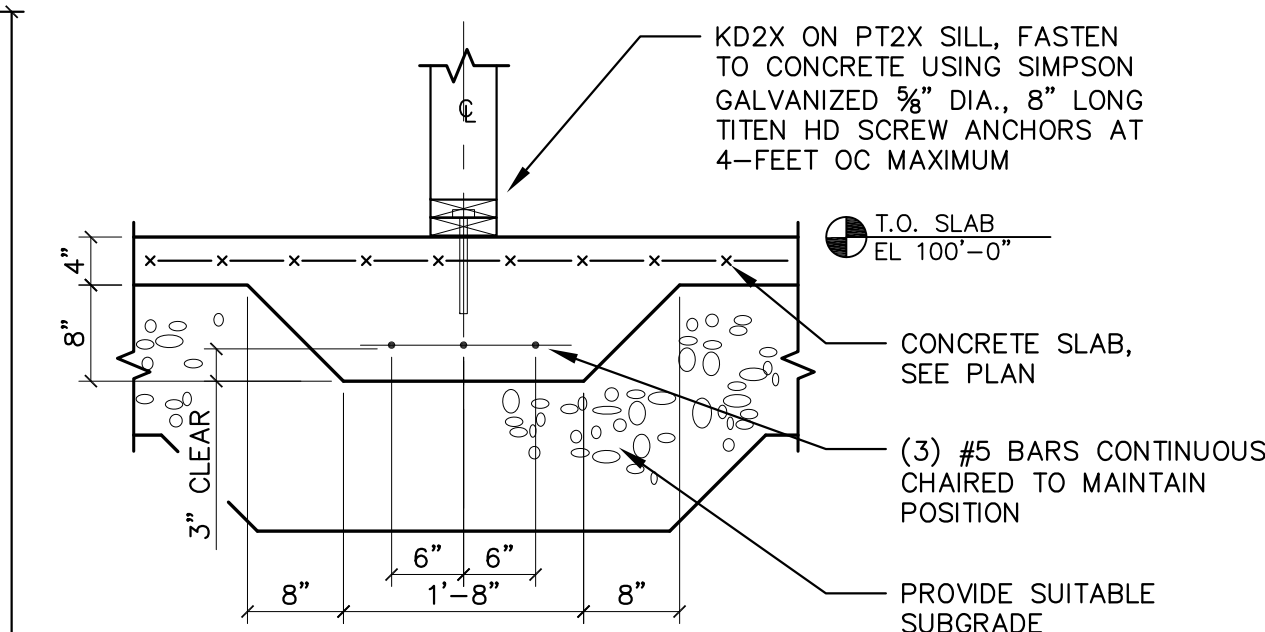

**2 THICKENED SLAB DETAIL**  
S1.0 SCALE: 1/4"=1'-0"

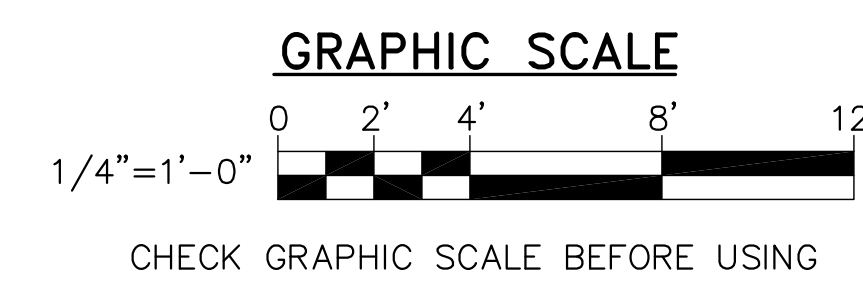

PROJECT:  
KEY:

**McHENRY ARCHITECTURE**  
4 Market Street  
Portsmouth, New Hampshire  
603.430.0274

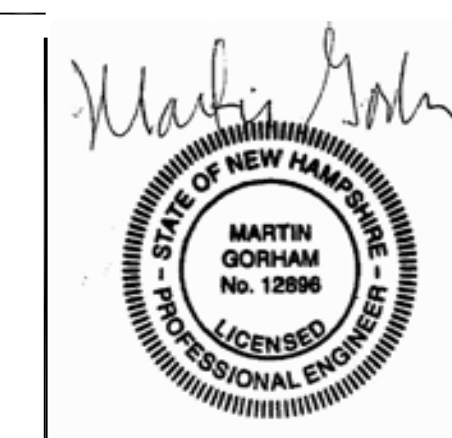

REVISIONS:  
BID SET

PROJECT NAME: Prescott Park Pavilion Building Portsmouth, NH  
PROJECT NO.: 10014  
DRAWN BY: JU  
APPROVED BY: SMcH  
ISSUE DATE: 16 SEPT 2013  
DRAWING NAME: FOUNDATION PLAN

SCALE: 1/4"=1'-0"  
DRAWING NO.: S1.0  
SHEET NO.: 1 of X

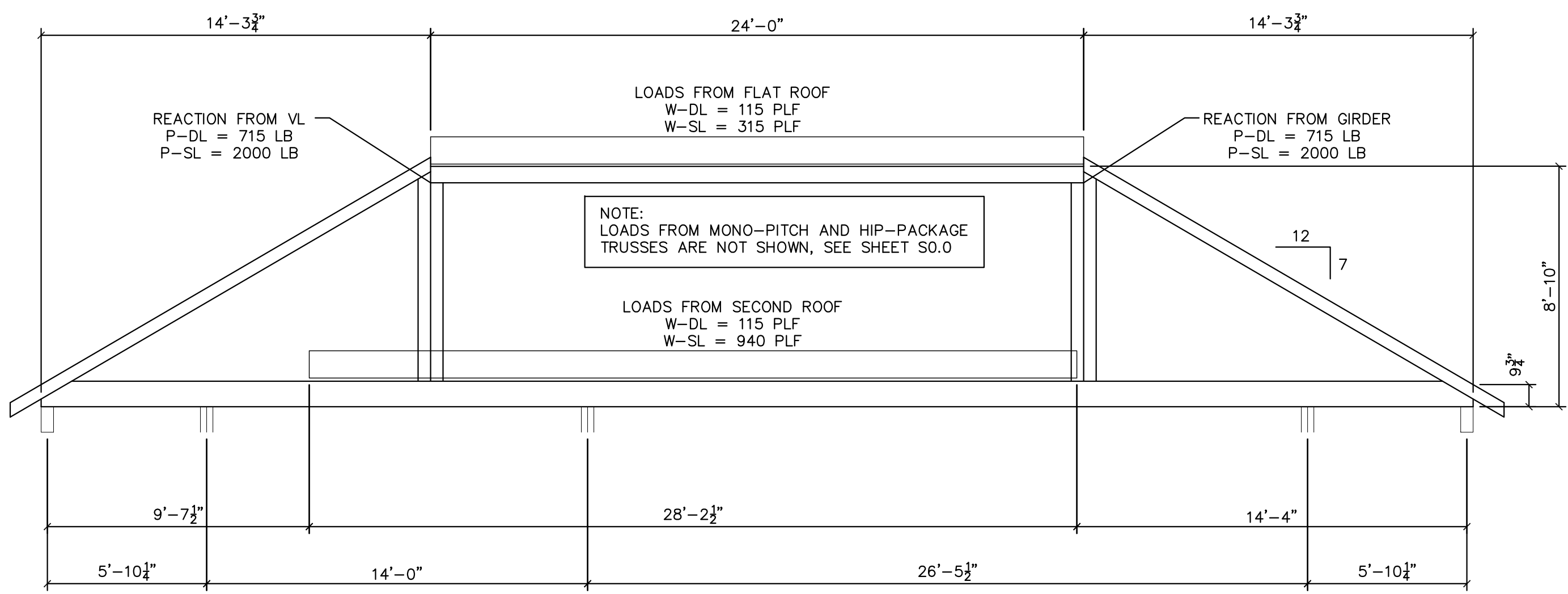

**3 GIRDER TRUSS LOAD DIAGRAM**  
S2.0 SCALE: 1/4"=1'-0"

- PT6X6 POSTS BASE AND CAP CONNECTIONS:**
- AT BASE OF ALL POSTS PROVIDE A SIMPSON ABA66Z (G185) MTL POST BASE, FASTEN TO PIER USING SIMPSON TITEN HD GALVANIZED ANCHOR  $\frac{5}{8}$ " $\times$ 6" MODEL #THD62600HMG, FASTEN TO POST USING (8) 16d HDG NAILS
  - AT CORNER POSTS, FASTEN TOP OF POST TO BEAM USING (2) SIMPSON ACE6Z (G185) POST CAP CONNECTORS FASTENED WITH (12) 16d HDG NAILS.
  - AT INSIDE POSTS, FASTEN TOP OF POST TO BEAM USING (2) SIMPSON ACEZ (G185) POST CAP CONNECTORS FASTENED WITH (16) 16d HDG NAILS.

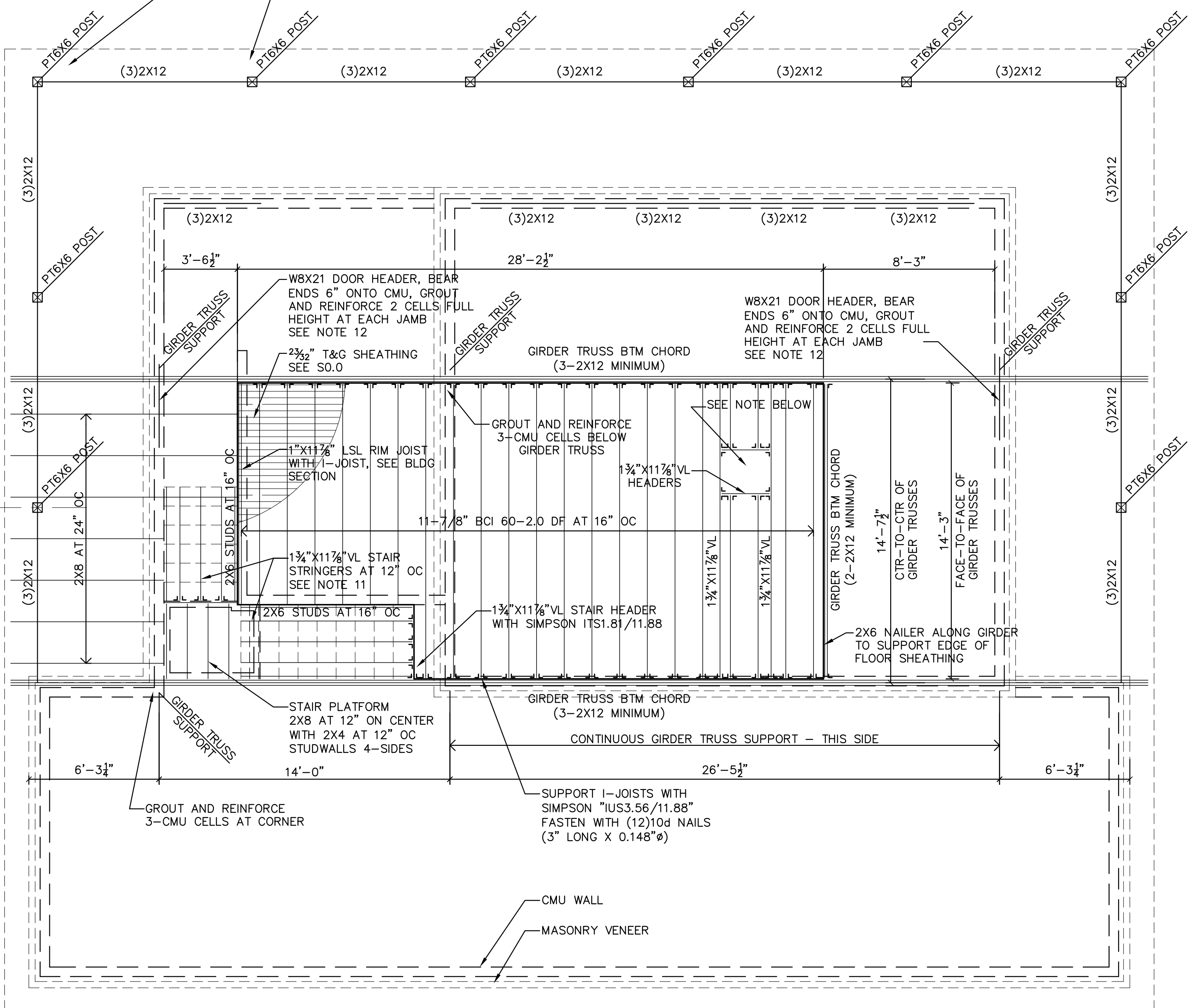

**1 SECOND LEVEL FRAMING PLAN**  
S2.0 SCALE: 1/4"=1'-0"

NOTE:  
FINAL LOCATION OF FLOOR MECHANICAL OPENINGS TO BE DETERMINED. WHERE I-JOIST MUST BE INTERRUPTED, FRAME OPENING WITH  $1\frac{3}{4}$ " $\times$ 11 $\frac{1}{8}$ " VL HEADERS AND TRIMMERS SUPPORT  $1\frac{3}{4}$ " $\times$ 11 $\frac{1}{8}$ " HEADERS USING SIMPSON ITS1.81/11.88 WITH (6)10d NAILS. SUPPORT  $11\frac{1}{8}$ " BCI CRIPPLE JOISTS USING SIMPSON IUS3.56/11.88 WITH (12)10d NAILS.

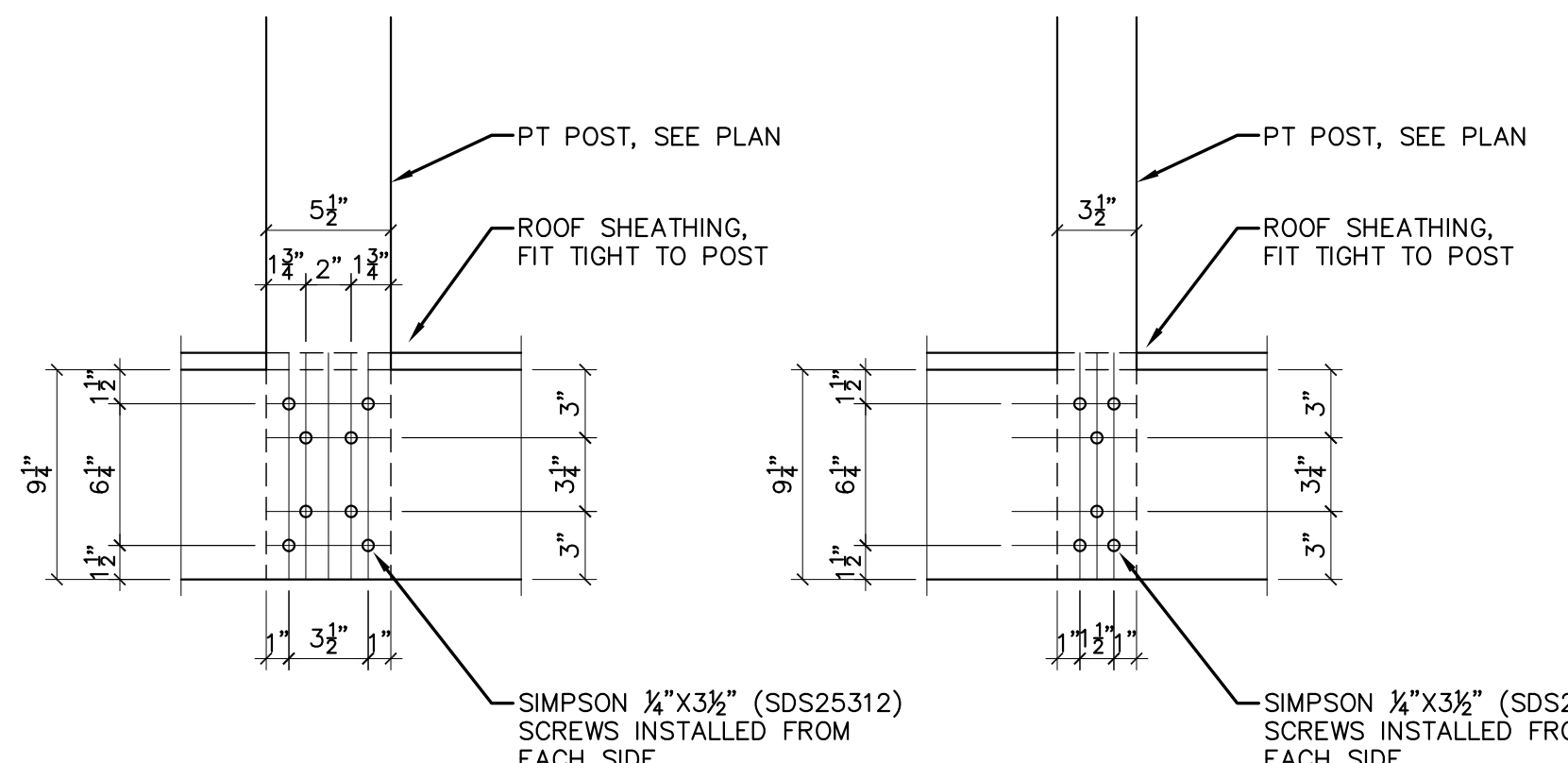

**4 GUARD RAIL POST DETAIL**  
S2.0 SCALE: 1-1/2"=1'-0"

**5 GUARD RAIL POST DETAIL**  
S2.0 SCALE: 1-1/2"=1'-0"

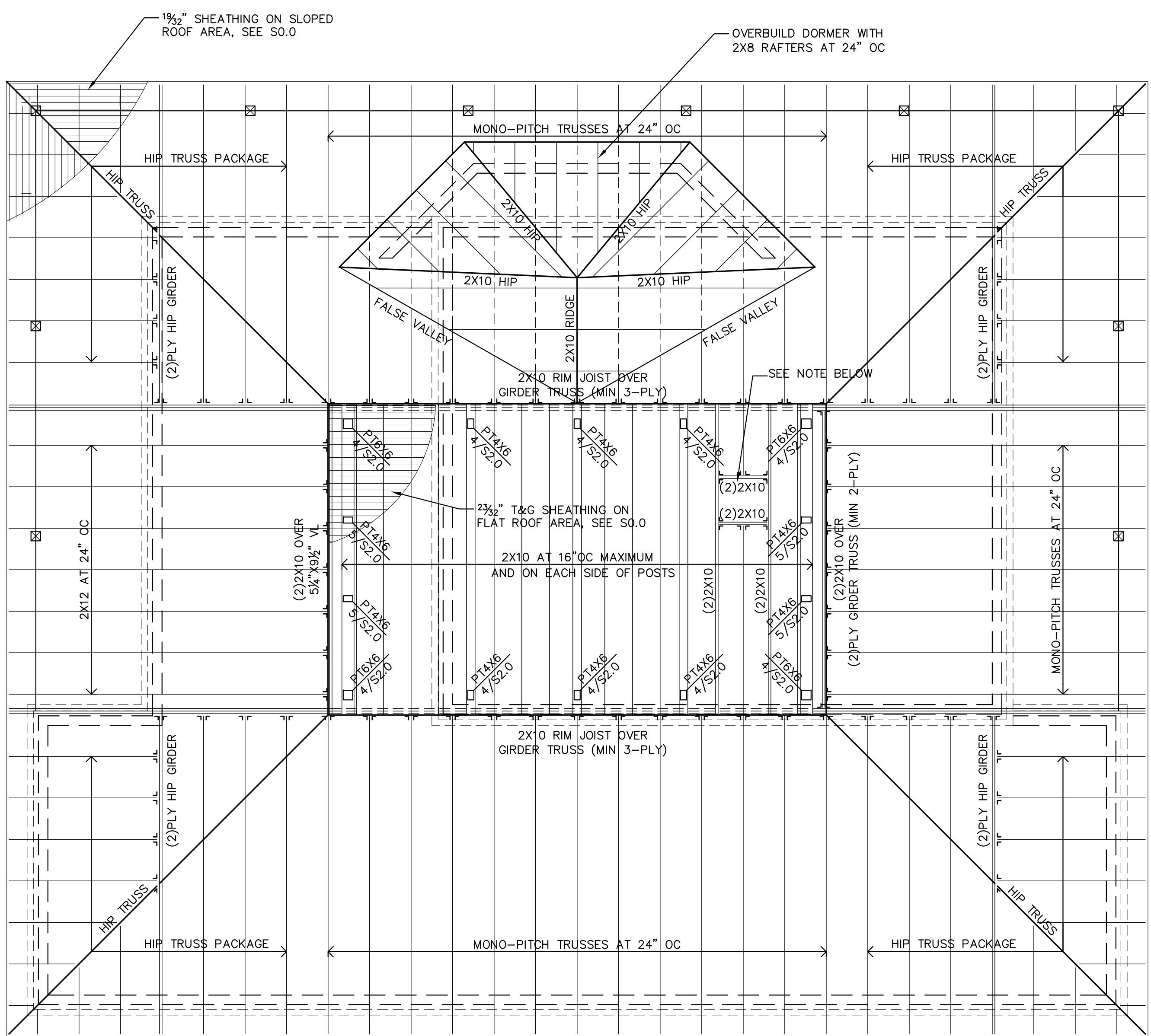

**2 ROOF FRAMING PLAN**  
S2.0 SCALE: 1/4"=1'-0"

NOTE:  
FINAL LOCATION OF FLAT ROOF MECHANICAL OPENINGS TO BE DETERMINED. WHERE JOIST MUST BE INTERRUPTED, FRAME OPENING WITH (2)2X10 HEADERS AND TRIMMERS SUPPORT (2)2X10 HEADERS USING SIMPSON LUS210-2 WITH (10)10d NAILS. SUPPORT 2X10 CRIPPLE JOIST USING SIMPSON LUS210 WITH (10)10d NAILS.

- NOTES**
- SEE SHEET S0.0 FOR STRUCTURAL NOTES AND ROOF TRUSS DESIGN LOADS.
  - GENERAL CONTRACTOR SHALL BE RESPONSIBLE FOR ANY AND ALL TEMPORARY BRACING NECESSARY TO HOLD FRAMING IN A SAFE AND STABLE CONDITION UNTIL ALL PERMANENT CONNECTIONS, BRACING, BRIDGING, AND DECKING ARE COMPLETE.
  - PROVIDE A SIMPSON HURRICANE ANCHOR MODEL H3Z AT EACH RAFTER BEARING.
  - ALL ROOF SHEATHING SHALL BE ADVANTECH BRAND 5/8" THICK APA-RATED EXPOSURE-1 T&G SHEATHING OR APPROVED EQUAL.
  - INDIVIDUAL SHEATHING PANELS SHALL SPAN A MINIMUM OF TWO FRAMING BAYS.
  - AT FALSE VALLEYS PROVIDE A 2X10 NAILER FLAT ON THE LOWER ROOF SHEATHING.
  - SEE THE ARCHITECTURAL DRAWINGS FOR ALL RAKE AND EAVE OVERHANG DETAILS AND DIMENSIONS.
  - THE TRUSS MANUFACTURER SHALL SPECIFY AND PROVIDE ALL METAL CONNECTORS REQUIRED TO SUPPORT THE TRUSSES.
  - THE TRUSS MANUFACTURER SHALL SPECIFY THE QUANTITY AND SIZE OF ALL FASTENERS REQUIRED FOR THE METAL HANGERS.
  - GIRDER TRUSSES MAY REQUIRE ADDITIONAL PLYS TO SATISFY LOADING AND BEARING REQUIREMENTS. THIS WILL BE COORDINATED WITH TRUSS MANUFACTURER/DESIGNER.
  - FRAME STAIRS WITH  $1\frac{3}{4}$ " $\times$ 11 $\frac{1}{8}$ " VL STRINGERS SPACED AT 12" ON CENTER MAXIMUM. SHEATH TREADS AND RISERS WITH  $\frac{3}{8}$ " WOOD STRUCTURAL PANELS, APA RATED STURD-I-FLOOR. FASTEN OUTSIDE STRINGERS TO ADJACENT WALL FRAMING WITH (3)16d NAILS AT EACH STUD. FASTEN TOP OF STRINGERS TO FLOOR OR PLATFORM FRAMING USING SIMPSON LSC STRINGER CONNECTORS FASTENED WITH (17)10d x  $1\frac{1}{2}$ " NAILS.
  - AT W8X21 HEADERS IN CMU WALL PROVIDE CMU SOAPS ON INSIDE FACE TO MATCH ADJACENT WALLS. PROVIDE CONTINUOUS BOND BEAM OVER TOP OF WB.

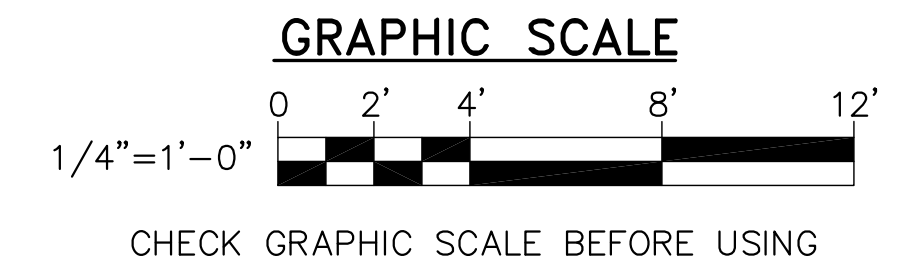

PROJECT:  
KEY:

**McHENRY ARCHITECTURE**  
4 Market Street  
Portsmouth, New Hampshire  
603.430.0274



REVISIONS:  
BID SET

PROJECT NAME: Prescott Park Pavilion Building Portsmouth, NH  
PROJECT NO.: 10014  
DRAWN BY: JU  
APPROVED BY: SMcH  
ISSUE DATE: 16 SEPT 2013  
DRAWING NAME: FLOOR AND ROOF FRAMING PLANS

SCALE: 1/4"=1'-0"  
DRAWING NO.: **S2.0**  
SHEET NO.: 1 of X

LUMINAIRE SCHEDULE						
SYMBOL	LABEL	MANUF	CATALOG NUMBER	DESCRIPTION	LAMP	WATTS
	A	HILITE	HARBOR H-1351-B-91-FR	EXTERIOR GOOSENECK FIXTURE: 91 BLACK; GLASS: FROST; COMPACT FLUORESCENT LIGHT	(1) 42W CFL	45
	B	HILITE	NEPTUNE H-62210-B-105-FR	EXTERIOR SCONCE: 91 BLACK; GLASS: FROST; COMPACT FLUORESCENT LIGHT	(1) 42W CFL	45
	C	HILITE	HARBOR H-1380; MOUNTING: CB8	PENDANT; 91 BLACK; GLASS: FROST; COMPACT FLUORESCENT LIGHT	(1) 42W CFL	45
	D	FOCAL POINT	FL4D-RO-T-L4-RO	LED DOWNLIGHT, CLEAR DIFFUSE REFLECTOR	(1) 24W LED	24
	E	KIM LIGHTING	AFL21	FLOOD LIGHT; WIDE FLOOD, LEXAN SLX SHIELD, WALL VERTICAL MOUNT OPTION	(1) 250W MH	280
	F	COOPER LIGHTING	RIO 1237-RD	UTILITY LIGHT; DIE CAST ALUMINUM	(1) 12W LED	12
	G	FOCAL POINT	FV2S	WORK LIGHT; VERVE II SUSPENDED LINEAR INDIRECT/DIRECT FLUORESCENT	(2) T5HO	120
	H	LITHONIA	LB-2-28T5-MVOLT	SURFACEMOUNTED WRAP, 10" WIDE X 48" LONG, WITH CURVED PRISMATIC DIFFUSER.	(2) T5HO	120
	EB	LITHONIA	ELM	EMERGENCY LIGHTING WITH 2 FIXED LAMP HEADS, 6VDC, THERMOPLASTIC UNIT WITH SEALED LEAD CALCIUM BATTERY, WHITE	2 - 5.4W TUNGSTEN LAMPS	11
	EBE	LITHONIA	XTC 2RW	COMBINATION EMERGENCY LIGHTING & EXIT SIGN, WITH ADJUSTABLE LAMP HEADS, THERMOPLASTIC UNIT, 6VDC WITH SEALED LEAD CALCIUM BATTERY, WHITE, EXIT SIGN HAS HI-OUTPUT LED	2 - 5.4W TUNGSTEN LAMPS	15
	EX	LITHONIA (QUANTUM SERIES)	LQM-S-W-3-R-120/277-ELN, WITH PCS-1 SHIELD	EXIT SIGN, ENERGY STAR, POLYCARBONATE HOUSING, VANDAL RESISTANT SHIELD, UNIVERSAL MOUNTING CAPABILITY, MAINTENANCE FREE NI-CAD BATTERY, SINGLE FACE EXIT WITH EXTRA FACEPLATE FOR CONVERSION TO DOUBLE FACE. KNOCKOUTS FOR CHOICE OF DIRECTION.	LED	5

RECEPTACLES AND FIXED EQUIPMENT CONNECTIONS

	DUPLEX CONVENIENCE RECEPTACLE - 18" A.F.F		ELECTRIC METER
	QUADPLEX CONVENIENCE RECEPTACLE - 18" A.F.F		POWER PANEL, SURFACE MOUNTED
	DUPLEX RECEPTACLE GROUND FAULT INTERRUPT, - 18" A.F.F. (SP INDICATES SURGE PROTECTOR)		POWER PANEL, RECESSED
	SAFETY SWITCH - REFER TO MECHANICAL EQUIPMENT SCHEDULE FOR RATING		HOMERUN TO PANEL "P1" CIRCUITS 1 & 3 - DIAGONAL LINES INDICATE NUMBERS OF CONDUCTORS WHEN MORE THAN TWO.
	SAFETY SWITCH WITH FUSE - REFER TO MECHANICAL EQUIPMENT SCHEDULE FOR RATING		JUNCTION BOX - CEILING MOUNTED
			JUNCTION BOX - WALL MOUNTED
	SMOKE DETECTOR - CEILING MOUNT		DATA OUTLET - CENTERLINE 18" A.F.F
	HEAT DETECTOR - "H" INDICATES FIXED AT 190° F		VOICE/DATA OUTLET - CENTERLINE 18" A.F.F
	HEAT DETECTOR - "F" INDICATES FIXED AT 135° F		VOICE/DATA OUTLET - CENTERLINE 4'-6" A.F.F
	MANUAL PULL STATION - CENTERLINE 4'-0" AFF		VOICE/DATA OUTLET - MOUNTED ABOVE COUNTER OR BACKSPLASH
	AUDIO / VISUAL SIGNAL - CENTERLINE 6'-8" AFF		
	FIRE ALARM CONTROL PANEL		

SWITCHES

	SINGLE POLE SWITCH, 42" AFF
	THREE WAY SWITCH, 42" AFF

GENERAL NOTES

- ALL WIRING SHALL BE SURFACE MOUNTED UNLESS SPECIFIED OTHERWISE.
- ALL EQUIPMENT SHALL BE INSTALLED IN A NEAT AND WORKMANLIKE MANNER, RECTILINEAR TO BUILDING STRUCTURE.
- ALL COMPONENTS SHOWN ON RISER DIAGRAMS, BUT NOT ON THE PLAN OR VICE VERSA, SHALL BE INCLUDED AS IF SHOWN ON BOTH.
- REFER TO MECHANICAL DRAWINGS FOR EXACT LOCATION OF MECHANICAL EQUIPMENT THAT REQUIRE ELECTRICAL CONNECTIONS.
- ALL RACEWAYS RUNNING THROUGH BUILDING EXPANSION JOINTS SHALL BE EQUIPPED WITH EXPANSION FITTINGS.
- CONDUIT HOMERUNS SHOWN ON THE DRAWING WITH MORE THAN 3 CURRENT CARRYING CONDUCTORS ARE SHOWN DIAGRAMMATICALLY, THE ELECTRICAL CONTRACTOR SHALL NOT INSTALL MORE THAN 3 CURRENT CARRYING CONDUCTORS IN A RACEWAY UNLESS DONE SO STRICTLY BY THE NATIONAL ELECTRIC CODE.
- ALL FLUSH MOUNTED PANELS SHALL HAVE EMPTY 1/2" CONDUIT STUBBED ABOVE ACCESSIBLE HUNG CEILING FOR FUTURE SPARE CIRCUITS.
- CONTRACTOR SHALL REVIEW ALL TRADES' CONTRACT DOCUMENTS TO DETERMINE SPECIFIC MOUNTING LOCATIONS FOR ELECTRICAL EQUIPMENT. COORDINATE EXACT MOUNTING LOCATIONS WITH THE ARCHITECT.
- REFER TO ARCHITECTURAL PLANS AND ELEVATIONS FOR MOUNTING HEIGHTS AND EXACT LOCATIONS OF ALL DEVICES.
- REVIEW ALL TRADES' CONTRACT DOCUMENTS TO DETERMINE SPECIFIC MOUNTING LOCATIONS FOR ELECTRICAL EQUIPMENT. COORDINATE EXACT MOUNTING LOCATIONS WITH THE ARCHITECT.
- ALL LIGHTING AND GENERAL POWER BRANCH CIRCUITS SHALL INCLUDE A SEPARATE NEUTRAL CONDUCTOR FOR EACH AND EVERY CIRCUIT UNLESS SPECIFICALLY NOTED OTHERWISE.
- REFER TO KITCHEN DRAWINGS FOR EXACT LOCATION OF KITCHEN EQUIPMENT THAT REQUIRE ELECTRICAL CONNECTIONS.

BRANCH CIRCUITS SCHEDULE

120 or 277 Volt, 1-Phase, 2W, Circuits	
Circuit Breaker	Conductor
30A - 1P	2#10, 1#10G, 3/4"C
40A - 1P	2#8, 1#10G, 3/4"C
50A - 1P	2#6, 1#10G, 3/4"C
60A - 1P	2#6, 1#10G, 3/4"C

208 Volt, 1-Phase, 2W, Circuits	
20A - 2P	2#12, 1#12G, 3/4"C
30A - 2P	2#10, 1#10G, 3/4"C
40A - 2P	2#8, 1#10G, 3/4"C
50A - 2P	2#6, 1#10G, 3/4"C
60A - 2P	2#6, 1#10G, 3/4"C

120/208 Volt, 1-Phase, 3W, Circuits	
20A - 2P	3#12, 1#12G, 3/4"C
30A - 2P	3#10, 1#10G, 3/4"C
40A - 2P	3#8, 1#10G, 3/4"C
50A - 2P	3#6, 1#10G, 3/4"C
60A - 2P	3#6, 1#10G, 3/4"C

208 or 480 Volt, 3-Phase, 3W, Circuits	
20A - 3P	3#12, 1#12G, 3/4"C
30A - 3P	3#10, 1#10G, 3/4"C
40A - 3P	3#8, 1#10G, 3/4"C
50A - 3P	3#6, 1#10G, 3/4"C
60A - 3P	3#6, 1#10G, 3/4"C

120/208 & 277/480 Volt, 3-Phase, 4W, Circuits	
20A - 3P	4#12, 1#12G, 3/4"C
30A - 3P	4#10, 1#10G, 3/4"C
40A - 3P	4#8, 1#10G, 3/4"C
50A - 3P	4#6, 1#10G, 1"C
60A - 3P	4#6, 1#10G, 1"C

Note:  
1. Type MC cable shall include full size insulated ground conductor sized as indicated in schedule.

DWG NO.	DRAWING NAME	REV.
E-1	ELECTRICAL SYMBOLS, LEGEND, NOTES, LIGHTING SCHEDULES	△
E-1A	SPECIFICATIONS, SCOPE OF WORK, UTILITY SERVICES RISER DIAGRAM	△
E-2	POWER, FIRE ALARM, TELEDATA RISER DIAGRAM, GROUNDING DIAGRAM	△
E-3	MECHANICAL & CIRCUIT SCHEDULES, TYPICAL DEVICE MTG HEIGHTS	△
E-4	PAVILION 1ST & 2ND FLOOR PLAN - POWER, TELE/DATA	△
E-5	PAVILION 1ST & 2ND FLOOR PLAN - LIGHTING	△
E-6	SUPPORT BUILDING FLOOR PLAN - POWER, TELE/DATA & LIGHTING	△
E-7	PAVILION & SUPPORT BUILDING - FIRE ALARM	△
E-8	SITE PLAN OF ELECTRIC UTILITIES	

GENERAL ABBREVIATIONS			
A	AMPERES	KVA	KILOVOLT AMPERES
ADA	AMERICANS WITH DISABILITIES AT	K	KILOWATTS
AFF	ABOVE FINISH FLOOR	LTG	LIGHTING
AFG	ABOVE FINISH GRADE	LFMC	LIQUID TIGHT FLEXIBLE METAL CONDUIT
AHJ	AUTHORITY HAVING JURISDICTION	MC	METAL CLAD CABLE
AHU	AIR HANDLING UNIT	MCB	MAIN CIRCUIT BREAKER
AIC	AMPERE INTERRUPTING CAPACITY	MC	MOTOR CONTROL CENTER
AL	ALUMINUM	MCP	MOTOR CIRCUIT PROTECTOR
ANSI	AMERICAN NAT'L STANDARDS INSTITUTE	MISC	MISCELLANEOUS
ARCH	ARCHITECT	MLO	MAIN LUGS ONLY
ATS	AUTOMATIC TRANSFER SWITCH	NC	NORMALLY CLOSED
ATC	AUTOMATIC TEMPERATURE CONTROL	NEC	NATIONAL ELECTRIC CODE
AWG	AMERICAN WIRE GAUGE	NFPA	NATIONAL FIRE PROTECTION ASSOC.
BFG	BELOW FINISH GRADE	NO	NORMALLY OPEN OR NUMBER
BLDG	BUILDING	NTS	NOT TO SCALE
C	CONDUIT	P	POLE
CAT	CATALOG	PB	PUSH BUTTON
CB	CIRCUIT BREAKER	PNL	PANEL
CL	CENTERLINE	POS	PROVIDED UNDER OTHER SECTIONS
CLF	CURRENT LIMITING FUSE	PVC	POLYVINYL CHLORIDE
COL	COLUMN	PWR	POWER
CPT	CONTROL POWER TRANSFORMER	QTY	QUANTITY
CT	CURRENT TRANSFORMER	REQ'D	REQUIRED
CU	COPPER	RMC	RIGID METAL CONDUIT
DWG	DRAWING	RMS	ROOT MEAN SQUARED
EC	ELECTRICAL CONTRACTOR	RNMC	RIGID NON-METALIC CONDUIT
EF	EXHAUST FAN	RTU	ROOF TOP UNIT
EMT	ELECTRICAL METALLIC TUBING	SP	SPARE
EPO	EMERGENCY POWER OFF	SW	SWITCH
EWC	ELECTRIC WATER COOLER	SYM	SYMMETRICAL
F	FUSE	TEL	TELEPHONE
FA	FIRE ALARM	TMCB	THERMAL MAGNETIC CIRCUIT BREAKER
FLA	FULL LOAD AMPERES	UG	UNDERGROUND OR UNDERGRADE
FMC	FLEXIBLE METAL CONDUIT	UL	UNDERWRITERS LABORATORIES
FT	FEET	V	VOLT
GND	GROUND OR GROUNDING	VT	VOLTAGE TRANSFORMER
GRMC	GALVANIZED RIGID METALLIC CONDUIT	W	WIRE
HOA	H... OFF, AUTOMATIC SWITCH	WH	WATER HEATER
IEEE	INSTITUTE OF ELECTRICAL & ELECTRONIC ENGINEERS	WP	WEATHER PROOF
IMC	INTERMEDIATE METAL CONDUIT	XFMR	TRANSFORMER
INT	INTERLOCK	Δ	DELTA
KMC	THOUSAND CIRCULAR MILS	Y	WYE
		∅	PHASE

SINGLE HEAVY DUTY RECEPTACLE WITH CORD AND CAP; 36" AFF EXCEPT AS NOTED

1	20A-125V, 2P, 3W, (5-20R)
2	30A-125V, 2P, 3W, (5-30R)(2#10 TO 30A-1P.)
3	50A-125V, 2P, 3W, (5-50R)(2#8 TO 50A-1P.)
4	20A-250V, 2P, 3W, (2#12 TO 20A-2P.)
5	30A-250V, 2P, 3W, (6-30R)(2#10 TO 30A-2P.)
6	50A-250V, 2P, 3W, (6-50R)(2#8 TO 50A-2P.)
7	30A-125/250V, 3P, 3W, (10-30R)(3#10 TO 30A-2P.)
8	50A-125/250V, 3P, 3W, (10-50R)(3#8 TO 50A-2P.)
9	30A-125/250V, 3P, 4W, (14-30R)(3#10 TO 30A-2P.)
10	50A-125/250V, 3P, 4W, (14-50R)(3#6 TO 50A-2P.)

**McHENRY ARCHITECTURE**  
 4 Market Street  
 Portsmouth, New Hampshire  
 603.430.0274

**Seacoast Consulting Engineers, LLC**  
 261 Jericho Lane  
 Epsom, Maine 03903  
 207-370-7230  
 www.SeacoastEngineers.com  
 Project No. 2012-107  
 Scale As Noted  
 03-09-2012

**Pavilion Building  
 Prescott Park  
 Portsmouth, NH**  
 Electrical Symbols, Legend, Notes,  
 Lighting Schedule

E1

**ELECTRICAL SPECIFICATIONS**

**PART 1 - GENERAL**

1. GENERAL PROVISIONS: DRAWINGS ARE DIAGRAMMATIC AND INDICATE GENERAL ARRANGEMENT OF WORK IN CONTRACT. REFER TO ALL DRAWINGS ASSOCIATED WITH THIS PROJECT (EACH TRADE) FOR EXACT LOCATION OF ALL EQUIPMENT AND REQUIRED MOUNTING HEIGHTS.
2. SCOPE: PERFORM WORK AND PROVIDE NEW MATERIAL AND EQUIPMENT AS SHOWN ON DRAWINGS AND AS SPECIFIED IN THIS SECTION OF THE SPECIFICATIONS. PROVIDE ALL COMPONENTS AND MATERIALS, WHETHER SPECIFICALLY SHOWN OR NOT, THAT ARE NECESSARY TO MAKE THE SYSTEMS COMPLETE AND FULLY OPERATIONAL. WORK SHALL INCLUDE, BUT NOT BE LIMITED TO: 1) REMOVAL OF EXISTING ELECTRICAL SYSTEM AT THE CONCESSION BUILDING, 2) INSTALLATION OF NEW POWER DISTRIBUTION, LIGHTING AND FIRE ALARM SYSTEM AS ILLUSTRATED ON THESE DRAWINGS, 3) ALL TESTING AND CERTIFICATIONS NECESSARY FOR COMPLIANCE AND ANY REQUIRED REMEDIAL ACTIONS AND RETESTING DUE TO FAILURE.
3. SITE VISIT: VISIT AND CAREFULLY EXAMINE SITE TO IDENTIFY EXISTING CONDITIONS THAT MAY AFFECT WORK OF THIS SECTION BEFORE SUBMITTING BID. NO EXTRA PAYMENT WILL BE ALLOWED FOR ADDITIONAL WORK CAUSED BY UNFAMILIARITY WITH SITE CONDITIONS THAT ARE VISIBLE OR READILY DISCERNED.
4. RELATED WORK: THE FOLLOWING WORK IS NOT INCLUDED IN THIS SECTION AND WILL BE PROVIDED UNDER OTHER SECTIONS: 1) TEMPORARY LIGHTING AND POWER FOR USE DURING CONSTRUCTION AND TESTING UNLESS SPECIFICALLY NOTED IN OTHER SPECIFICATION SECTIONS, 2) PAINTING.
5. CODES, STANDARDS, AUTHORITIES AND PERMITS: ALL WORK SHALL BE PERFORMED IN ACCORDANCE WITH THE LATEST EDITIONS OF THE STATE BUILDING CODE, THE STATE ELECTRICAL CODE, NFPA, ANSINCEA INSTALLATION STANDARDS AND OTHER APPLICABLE CODES, REGULATIONS AND LAWS OF LOCAL, STATE AND FEDERAL GOVERNMENT, OTHER AUTHORITIES HAVING JURISDICTION AND APPLICABLE BASE BUILDING STANDARDS AND SPECIFICATIONS. CODES, LAWS AND ORDINANCES PROVIDE A BASIS FOR THE MINIMUM INSTALLATION CRITERIA. THESE DRAWINGS AND SPECIFICATIONS ILLUSTRATE THE SCOPE REQUIRED FOR THIS PROJECT, WHICH MAY EXCEED MINIMUM CODE, LAW AND STANDARDS CRITERIA. GIVE NOTICES, FILE PLANS, OBTAIN PERMITS AND LICENSES, PAY BACKCHARGES AND OBTAIN NECESSARY APPROVALS FROM UTILITY COMPANIES AND AUTHORITIES HAVING JURISDICTION AS REQUIRED FOR THE EXECUTION OF ALL WORK ASSOCIATED WITH THIS PROJECT.
6. INTERPRETATION OF DOCUMENTS: ADVISE THE ENGINEER IN WRITING (RFI) PRIOR TO PROCEEDING WITH PROCUREMENT OR INSTALLATION THAT THE DESIGN INTENT IS UNCLEAR OR THAT CONSTRUCTION DOCUMENTS DO NOT COINCIDE WITH MANUFACTURER'S RECOMMENDATIONS. ALL COSTS FOR REWORK NECESSARY TO RESOLVE DISCREPANCIES SHALL BE THE RESPONSIBILITY OF THE CONTRACTOR.
7. REQUEST FOR INFORMATION: RFI ISSUED TO RESOLVE A CONFLICT OR DISCREPANCY SHALL BE PROVIDED WITH THE PREFERRED SOLUTION VIA WRITTEN DESCRIPTION OR SKETCH.
8. SUBMITTALS: PROVIDE SPECIFIED MATERIALS AND EQUIPMENT UNLESS "EQUAL" OR "APPROVED EQUAL" IS EXPLICITLY INDICATED ON THE DRAWINGS. DEVIATIONS TO SPECIFIED MATERIALS SHALL BE AT THE SOLE RISK OF THE CONTRACTOR, WHO SHALL BE RESPONSIBLE FOR ALL ASSOCIATED CHANGES TO THIS AND OTHER TRADES. SUBMITTALS SHALL INDICATE REVIEW AND APPROVAL BY THE RESPONSIBLE CONTRACTOR. SUBMIT FOR REVIEW (6) SETS OF MANUFACTURER'S PRODUCT DATA FOR DEVICES (RECEPTACLES AND SWITCHES) AND PLATES; PANELBOARDS, CIRCUIT BREAKERS; DISCONNECT SWITCHES. ALLOW ENGINEER A MINIMUM OF 10 WORKING DAYS FOR PROCESSING AND REVIEW OF EACH SUBMISSION.
9. OPERATION AND MAINTENANCE DATA: SUBMIT (3) SETS OF OPERATING AND MAINTENANCE MANUALS INCLUDING SYSTEM DESCRIPTION, WIRING DIAGRAMS, WRITTEN WARRANTY, RECOMMENDED SPARE PARTS AND ROUTINE MAINTENANCE REQUIREMENTS WITH RECOMMENDED INTERVALS FOR ALL SUPPLIED EQUIPMENT.
10. RECORD DRAWINGS: CAD RECORD DRAWING FILES SHALL BE SUBMITTED AT THE COMPLETION OF THE PROJECT SHOWING THE "AS-BUILT" CONDITION INCLUDING WORK INSTALLED AND ALL MODIFICATIONS OR ADDITIONS TO ORIGINAL DESIGN. OBTAIN THE AUTOCAD FILES FOR PREPARATION OF AS-BUILT DRAWINGS FROM THE ARCHITECT. THE ARCHITECT AND ENGINEER ARE NOT GRANTING ANY OWNERSHIP OR PROPERTY INTEREST IN THE CAD DRAWINGS BY THE DELIVERY OF THE CAD FILES. THE RIGHTS TO USE THE CAD FILES AND DRAWINGS ARE LIMITED TO USE FOR THE SOLE PURPOSE OF ASSISTING IN THE PERFORMANCE OF CONTRACTUAL OBLIGATIONS WITH RESPECT TO THIS PROJECT. ANY REUSE AND/OR OTHER USE WILL BE AT THE CONTRACTOR'S SOLE RISK AND WITHOUT LIABILITY TO THE ARCHITECT AND ENGINEER.
11. WARRANTIES: WARRANTY INSTALLATION IN WRITING FOR ONE YEAR FROM DATE OF OWNER'S ACCEPTANCE OF CERTIFICATE OF SUBSTANTIAL COMPLETION. REPAIR, REPLACE OR PROVIDE TEMPORARY ACCOMMODATIONS FOR DEFECTIVE MATERIALS, EQUIPMENT, WORKMANSHIP AND INSTALLATION THAT DEVELOP WITHIN 24 HOURS OF NOTIFICATION. WARRANTY SHALL INCLUDE A CONTACT PERSON (NAME AND 24 HOUR TELEPHONE NUMBER) FOR SERVICE REQUESTS. CORRECT DAMAGE CAUSED WHILE MAKING NECESSARY REPAIRS AND REPLACEMENTS UNDER WARRANTY PERIOD AT NO ADDITIONAL COST.
12. COORDINATION: CONFER WITH ALL OTHER TRADES RELATIVE TO LOCATION OF ALL APPARATUS AND EQUIPMENT TO BE INSTALLED AND SELECT LOCATIONS SO AS NOT TO CONFLICT WITH OR HINDER PROGRESS OF WORK OF OTHER SECTIONS. WORK INSTALLED THAT CREATES INTERFERENCE OR RESTRICTS ACCESS REQUIRED BY CODE OR TO CONDUCT MAINTENANCE AND/OR ADJUSTMENTS SHALL BE MODIFIED AT NO ADDITIONAL COST TO THE OWNER.
13. SUPPORTS: INCLUDE ALL STRUCTURAL STEEL SUPPORTS, HANGER BRACKETS, ETC., REQUIRED FOR THE EXECUTION OF THE WORK OF THIS SECTION. HANGERS SHALL BE PREFINISHED CHANNEL AND THREADED ROD USED WITH APPROVED CLAMPS, HARDWARE, ETC. CHANNEL INSTALLED IN EXTERIOR LOCATIONS SHALL BE GALVANIZED STEEL WITH STAINLESS STEEL HARDWARE.
14. CUTTING AND PATCHING: INCLUDE ALL CORING, CUTTING, PATCHING AND FIREPROOFING NECESSARY FOR THE EXECUTION OF THE WORK OF THIS SECTION. STRUCTURAL ELEMENTS SHALL NOT BE CUT WITHOUT WRITTEN APPROVAL OF THE ARCHITECT. PROVIDE FIRE STOPPING TO MAINTAIN THE FIRE RATING OF THE FIRE RESISTANCE-RATED ASSEMBLY. ALL PENETRATIONS AND ASSOCIATED FIRE STOPPING SHALL BE INSTALLED IN ACCORDANCE WITH THE FIRE STOPPING MANUFACTURER'S LISTED INSTALLATION DETAILS AND BE LISTED BY UL OR FM.
15. HOISTING, SCAFFOLDING AND PLANKING: INCLUDE THE FURNISHING, SET-UP AND MAINTENANCE OF ALL HOISTING MACHINERY, CRANES, SCAFFOLDS, STAGING AND PLANKING AS REQUIRED FOR THE EXECUTION OF WORK FOR THIS SECTION.
16. SAFETY PRECAUTIONS: LIFE SAFETY AND ACCIDENT PREVENTION SHALL BE A PRIMARY CONSIDERATION. COMPLY WITH ALL OF THE SAFETY REQUIREMENTS OF THE OWNER AND OSHA THROUGHOUT THE ENTIRE CONSTRUCTION PERIOD OF THE PROJECT. FURNISH, PLACE AND MAINTAIN PROPER GUARDS AND ANY OTHER NECESSARY CONSTRUCTION REQUIRED TO SECURE SAFETY OF LIFE AND PROPERTY.
17. ACCESSIBILITY: ALL WORK PROVIDED UNDER THIS SECTION OF THE SPECIFICATION SHALL BE SO THAT PARTS REQUIRING PERIODIC INSPECTION, MAINTENANCE AND REPAIR ARE READILY ACCESSIBLE. WORK OF THIS TRADE SHALL NOT INFRINGE UPON CLEARANCES

**REQUIRED BY EQUIPMENT OF OTHER TRADES.**

18. PROTECTION OF WORK AND PROPERTY: THIS CONTRACTOR SHALL BE RESPONSIBLE FOR THE CARE AND PROTECTION OF ALL WORK INCLUDED UNDER THIS SECTION UNTIL THE COMPLETION AND FINAL ACCEPTANCE OF THIS PROJECT. PROTECT ALL EQUIPMENT AND MATERIALS FROM DAMAGE FROM ALL CAUSES INCLUDING, BUT NOT LIMITED TO, FIRE VANDALISM AND THEFT. ALL MATERIALS AND EQUIPMENT DAMAGED OR STOLEN SHALL BE REPAIRED OR REPLACED WITH EQUAL MATERIAL OR EQUIPMENT AT NO ADDITIONAL COST TO THE OWNER. PROTECT ALL EQUIPMENT, OUTLETS AND OPENINGS, AND ROOF PENETRATIONS WITH TEMPORARY PLUGS, CAPS AND COVERS. PROTECT WORK AND MATERIALS OF OTHER TRADES FROM DAMAGE THAT MIGHT BE CAUSED BY WORK OR WORKMEN UNDER THIS SECTION AND MAKE GOOD DAMAGE THUS CAUSED. DAMAGED MATERIALS ARE TO BE REMOVED FROM THE SITE; NO SITE STORAGE OF DAMAGED MATERIALS WILL BE ALLOWED. ANY DAMAGE TO EXISTING SYSTEMS AND EQUIPMENT CAUSED BY THIS CONTRACTOR DURING INSTALLATION SHALL BE REPAIRED AND/OR REPLACED AT THIS CONTRACTOR'S EXPENSE TO THE COMPLETE SATISFACTION OF THE BUILDING OWNER.
19. SEISMIC RESTRAINT REQUIREMENTS: PROVIDE SEISMIC RESTRAINTS AS REQUIRED IN ACCORDANCE WITH THE STATE BUILDING CODE. A REGISTERED PROFESSIONAL STRUCTURAL ENGINEER, LICENSED IN THE APPLICABLE STATE FOR THE PROJECT LOCATION, SHALL PREPARE THE SEISMIC RESTRAINT DESIGN AND CERTIFY THAT THE DESIGN IS IN COMPLIANCE WITH THE STATE BUILDING CODE REQUIREMENTS.
20. PROJECT CLOSEOUT: A CERTIFICATE OF COMPLETION SHALL BE ISSUED BY THE CONTRACTOR INDICATING THAT THE INSTALLATION IS IN CONFORMANCE WITH THE CONSTRUCTION DOCUMENTS AND ALL APPLICABLE LOCAL, STATE AND FEDERAL STATUTES AND CODES. ALL SUBMITTALS, AS-BUILTS, O&M MANUALS, AND BALANCING REPORTS ARE TO BE PROVIDED, FOR ENGINEER'S REVIEW, PRIOR TO REQUEST FOR COMPLETION CERTIFICATES. IN ADDITION, AND ALSO PRIOR TO REQUEST FOR COMPLETION CERTIFICATES, ALL PUNCH LIST ITEMS MUST BE COMPLETED TO THE SATISFACTION OF THE ENGINEER. THE CONTRACTOR MUST VERIFY THAT ALL SEQUENCES OF OPERATIONS AND CONTROLS HAVE BEEN INCORPORATED AND ALL SYSTEMS AND EQUIPMENT ARE WORKING PER THE SPECIFIED SEQUENCES OF OPERATIONS.

**PART 2 - PRODUCTS**

1. IDENTIFICATION: NAMEPLATES SHALL INDICATE EQUIPMENT TAG, VOLTAGE CHARACTERISTICS AND SOURCE OF POWER. REFER TO NAMEPLATE DETAIL FOR ADDITIONAL INFORMATION.
2. RACEWAYS AND CONDUIT: RIGID GALVANIZED STEEL CONDUIT (RGS) SHALL BE UTILIZED WITH THREADED FITTINGS ONLY. ELECTRICAL METALLIC TUBING (EMT) SHALL BE UTILIZED WITH COMPRESSION COUPLINGS, PROVIDE CONDUIT EXPANSION FITTINGS WITH EXTERNAL BONDING JUMPERS EQUAL TO OZ GEDNEY TYPE EX FOR RGS AND TYPE TX FOR EMT WHEN CROSSING EXPANSION JOINTS. UL LISTED LIQUID TIGHT FLEXIBLE METAL CONDUIT (LFMC) AND FLEXIBLE METAL CONDUIT (FMC) SHALL BE USED FOR FINAL CONNECTIONS TO EQUIPMENT WHERE FLEXIBILITY OR VIBRATION ISOLATION ARE REQUIRED. LFMC SHALL BE UV RESISTANT WHEN INSTALLED IN AN EXTERIOR LOCATION.
3. WIRE AND CABLE: ALL CONDUCTORS SHALL BE TYPE THHN/THWN OR XHHW, COPPER, RATED 75/90°C, 600 VOLT INSULATION UNLESS OTHERWISE NOTED. MINIMUM SIZE CONDUCTOR SHALL BE #12 AWG COPPER. CONDUCTORS #10 AWG AND LARGER SHALL BE STRANDED; #12 AWG AND SMALLER SHALL BE SOLID. EACH BRANCH CIRCUIT AND FEEDER SHALL BE PROVIDED WITH AN INSULATED GROUNDING CONDUCTOR SIZED IN ACCORDANCE WITH NEC TABLE 250.122. CONDUCTOR COLOR CODING SHALL BE IN ACCORDANCE WITH THE DETAILS ON THESE DRAWINGS. COLOR CODING SHALL BE CONSISTENT THROUGHOUT INCLUDING CONDUCTORS INSTALLED IN RACEWAYS AND IN ALL CABLE ASSEMBLIES (MC AND/OR AC). FLEXIBLE METAL CLAD (MC) CABLE SHALL BE UL LISTED WITH INSULATED THHN PHASE AND GROUND CONDUCTORS WITHIN A GALVANIZED STEEL OR ALUMINUM INTERLOCKING ARMOR.
4. WIRING DEVICES AND PLATES: ALL DEVICES SHALL BE SPECIFICATION GRADE WITH NYLON PLATE, COLOR AS SPECIFIED BY THE ARCHITECT OR TO MATCH EXISTING. ALL DEVICES SHALL HAVE A GREEN GROUNDING TERMINAL ON THE YOKE. RECEPTACLES SHALL BE UL FEDERAL SPECIFICATION WC-596 EXTRA HEAVY DUTY 20A 125V EQUAL TO COOPER 536Z. GFCI RECEPTACLES SHALL BE COMMERCIAL SPECIFICATION GRADE 20A 125V EQUAL TO COOPER GF20. SWITCHES SHALL BE INDUSTRIAL-INSTITUTIONAL HEAVY DUTY SPECIFICATION GRADE 20A 120/277V EQUAL TO COOPER 2200 SERIES.
5. SAFETY DISCONNECT SWITCHES: DISCONNECT SWITCHES SHALL BE THREE-POLE HEAVY DUTY TYPE RATED FOR 600 VOLT IN NEMA 1 (INTERIOR DRY APPLICATIONS) AND NEMA 3R (EXTERIOR APPLICATIONS) ENCLOSURES UNLESS NOTED OTHERWISE ON THE DRAWINGS. ALL SWITCHES SHALL BE HORSEPOWER RATED AND SUITABLE FOR SERVICE ENTRANCE USE WHERE INDICATED ON THE DRAWINGS. PROVIDE WITH SOLID NEUTRAL WHERE FOUR WIRE CIRCUITS ARE ILLUSTRATED. MANUAL MOTOR STARTERS SHALL HAVE QUICK MAKE, QUICK BREAK TOGGLE MECHANISMS WITH ALLOWANCE FOR UP TO 10% FIELD ADJUSTMENT TO NOMINAL OVERLOAD HEATER VALUES. MANUAL MOTOR STARTERS SHALL BE SINGLE PHASE AND MAY BE USED FOR APPLICATIONS UP TO 1 HP AT 277 VOLT. ACCEPTABLE MANUFACTURERS SHALL BE SQUARE D, GE, SIEMENS OR EATON CUTLER-HAMMER.
6. PANELBOARDS SHALL BE CIRCUIT BREAKER TYPE WITH THERMAL MAGNETIC BOLT-ON MOLDED CASE CIRCUIT BREAKERS AND COPPER BUSES. MINIMUM INTERRUPTING CAPACITY SHALL BE 10,000 AMPS SYMMETRICAL AT 208 VOLT AND 14,000 AIC AT 480 VOLT. REFER TO PANEL SCHEDULES FOR EXACT AIC RATINGS OF EQUIPMENT. PANELBOARD COVERS SHALL BE DOOR-IN-DOOR DESIGN UP TO AND INCLUDING 400A. ACCEPTABLE MANUFACTURERS SHALL BE SQUARE D, GE, SIEMENS OR EATON CUTLER-HAMMER.
7. MAIN DISTRIBUTION PANELBOARD, SQUARE D I-LINE TYPE HCR-U WITH 1200 AMP, 3-POLE MAIN CIRCUIT BREAKER, OR EQUAL, SHALL BE CIRCUIT BREAKER TYPE WITH THERMAL MAGNETIC BOLT-ON MOLDED CASE CIRCUIT BREAKERS AND COPPER BUSES. MINIMUM INTERRUPTING CAPACITY SHALL BE 65,000 AMPS SYMMETRICAL AND SHALL BE RATED NEMA 3R FOR EXTERIOR APPLICATIONS. REFER TO PANEL SCHEDULES FOR EXACT AIC RATINGS OF EQUIPMENT.
8. FIRE ALARM SYSTEM: PROVIDE LABOR, MATERIALS, AND EQUIPMENT REQUIRED FOR COMPLETE INSTALLATION OF FIRE ALARM SYSTEM AS SHOWN ON FLOOR PLANS OF DRAWING.
  - a. FIRE ALARM CONTROL PANEL SHALL HAVE BATTERY BACK-UP AND SHALL BE MANUFACTURED BY HONEYWELL FIRE LITE ALARMS OR EQUAL, WITH 4-ZONES, CLASS B INITIATING DEVICE CIRCUITS AND COMPATIBLE WITH TWO- AND FOUR-WIRE INITIATING DEVICES.
  - b. SMOKE DETECTORS SHALL BE PHOTOELECTRIC TYPE SD-355, MANUFACTURED BY HONEYWELL FIRE LITE ALARMS OR EQUAL.
  - c. HORN/SROBE UNIT SHALL BE TYPE P2R, MANUFACTURED BY SYSTEM SENSOR OR EQUAL, WITH STANDARD CANDELA SETTINGS: 15, 15/75, 30, 75, 95, 110 & 115 CANDELA SETTINGS.
  - d. PULL STATION SHALL MANUFACTURED BY GE INTERLOGIX OR EQUAL, WITH MANUAL DUAL ACTION OPERATION, CAT 30 KEY RESET AND NON-CODED SPST.
  - e. HEAT DETECTORS SHALL BE FIXED TEMPERATURE/RATE-OF-RISE 135° F, MODEL 5601, MANUFACTURED BY HONEYWELL FIRE LITE ALARMS OR EQUAL.
9. NOT USED.

**PART 3 EXECUTION**

1. GENERAL: ALL INTERRUPTIONS AND SHUTDOWNS OF EXISTING ELECTRICAL SYSTEMS AND SERVICES SHALL BE AS SHORT AS POSSIBLE AND AT A TIME AND DURATION APPROVED BY THE OWNER AND ENGINEER. THE CONTRACTOR SHALL INCLUDE ALL PREMIUM TIME ASSOCIATED WITH THE SYSTEM AND SERVICE INTERRUPTIONS AND SHUTDOWNS.
  2. IDENTIFICATION: FURNISH AND INSTALL NAMEPLATES ON ALL ELECTRICAL EQUIPMENT INCLUDING PANELS, JUNCTION BOXES, DISCONNECT SWITCHES, TRANSFORMERS AND STARTERS.
  3. RACEWAYS AND CONDUIT: REFER TO POWER, LIGHTING AND FIRE ALARM DRAWINGS FOR ALLOWABLE WIRING METHODS. EMT MAY BE USED WITH SET SCREW FITTINGS IN CONCEALED AND EXPOSED LOCATIONS WHERE NOT EXPOSED TO PHYSICAL DAMAGE OR MOISTURE. USE RIGID GALVANIZED STEEL WITH THREADED FITTINGS WHERE EMT PROHIBITED. ALL RACEWAYS, WHICH PASS THROUGH BUILDING EXPANSION JOINTS, SHALL BE EQUIPPED WITH EXPANSION FITTINGS. ALL CONDUITS SHALL BE SUPPORTED IN AN APPROVED MANNER TO THE BUILDING STRUCTURE. SUPPORT FROM CONDUITS, DUCTWORK, PIPING, ETC. WILL NOT BE PERMITTED. RACEWAYS SHALL BE RUN CONCEALED UNLESS NOTED OTHERWISE, PERPENDICULAR AND/OR PARALLEL TO THE BUILDING STRUCTURE. NECA STANDARDS SHALL DEFINE MINIMUM QUALITY LEVEL FOR INSTALLATION WHERE APPLICABLE.
  4. WIRE AND CABLE: BRANCH CIRCUIT WIRING IS NOT ILLUSTRATED ON THE DRAWINGS AND IS INDICATED BY CIRCUIT NUMBERS NEXT TO FIXTURES, EQUIPMENT AND DEVICES. PROVIDE COMPLETE WIRING SYSTEM TO MEET ILLUSTRATED INTENT. CONDUIT HOMERUNS SHOWN ON THE DRAWINGS WITH MORE THAN 3 CURRENT CARRYING CONDUCTORS ARE SHOWN DIAGRAMMATICALLY. THE INSTALLATION OF MORE THAN 3 CURRENT CARRYING CONDUCTORS IN A COMMON RACEWAY SHALL REQUIRE THE DERATING OF ALL ASSOCIATED CONDUCTORS. ALL CIRCUITS SHALL CONTAIN A FULL SIZE, INSULATED GROUND CONDUCTOR.
  5. WIRING DEVICES AND PLATES: ALL DEVICES OTHER THAN 20A 120V SHALL BE CLEARLY LABELED WITH PERMANENTLY APPLIED NAMEPLATES (OR ENGRAVED FACEPLATES) DETAILING THE VOLTAGE CHARACTERISTICS AND CIRCUIT NUMBER.
  6. SAFETY DISCONNECT SWITCHES: FUSES SHALL BE CLASS RK-1 SIZED PER DRAWING AND NAMEPLATE REQUIREMENTS. INSTALL REJECTION CLIPS TO PROHIBIT INSTALLATION OF OTHER THAN CURRENT LIMITING FUSES.
  7. PANELBOARDS: THE CONTRACTOR SHALL BALANCE PANELBOARD LOADS TO WITHIN 10% PHASE TO PHASE. PROVIDE NEW AND/OR UPDATED TYPEWRITTEN DIRECTORIES OF BRANCH CIRCUITS IN ALL PANELBOARDS, NEW AND EXISTING, WHICH ARE MODIFIED UNDER THIS CONTRACT. INDICATE CIRCUIT CHANGES IN AS-BUILT RECORD DRAWINGS.
  8. EQUIPMENT TESTING AND CLEANING: CLEAN THE INTERIOR AND EXTERIOR OF ALL EQUIPMENT AT PROJECT COMPLETION OF ALL CONSTRUCTION DEBRIS AND RESIDUE. DAMAGED SURFACES SHALL BE REPAIRED AND FINISHES TOUCHED UP PAINT TO MATCH THE MANUFACTURER'S FINISH. EXTENSIVELY DAMAGED ENCLOSURES SHALL BE REPLACED.
- TEST THE INSULATION RESISTANCE BETWEEN EACH PHASE AND GROUND OF ALL FEEDERS ILLUSTRATED ON THE ONE LINE DIAGRAM. PROVIDE A TEST REPORT INDICATING THE RESULTS. REPLACE ALL CONDUCTORS THAT FAIL TO COMPLY WITH NETA TESTING STANDARDS. VERIFY VOLTAGE AT THE ASSOCIATED PANELBOARD UNDER LOAD AND ADJUST TAP SETTINGS AS REQUIRED TO DELIVER NOMINAL VOLTAGE DURING NORMAL AND LIGHTLY LOADED CONDITIONS.

**ELECTRICAL DEMOLITION NOTES**

1. REFER TO THE ARCHITECTURAL DRAWINGS FOR THE FULL EXTENT OF THE SCOPE OF DEMOLITION. DISCONNECT AND MAKE SAFE ALL ELECTRICAL EQUIPMENT IDENTIFIED FOR REMOVAL ON THE HVAC, PLUMBING AND FIRE PROTECTION PLANS. THE ELECTRICAL SCOPE MAY EXTEND BEYOND THE AREA DEFINED BY THE ARCHITECTURAL DEMOLITION LIMITS TO FULLY COMPLY WITH VARIOUS REQUIREMENTS DEFINED BY THESE NOTES.
2. THE ELECTRICAL CONTRACTOR SHALL BE RESPONSIBLE FOR THE REPAIR OF ALL SYSTEMS OR BUILDING COMPONENTS DAMAGED DURING THE EXECUTION OF THE WORK. DAMAGE SHALL INCLUDE BUT NOT BE LIMITED TO DESTRUCTION OR DISPOSAL OF ITEMS INTENDED TO REMAIN OR TO BE SALVAGED.
3. THE ELECTRICAL CONTRACTOR SHALL DE-ENERGIZE AND REMOVE ALL CONDUCTORS AND RACEWAYS TO THEIR POINTS OF ORIGIN WITHIN THE AREA OF DEMOLITION SCOPE. ITEMS IDENTIFIED FOR DEMOLITION SHALL NOT BE ABANDONED IN PLACE. RACEWAYS THAT ENTER MASONRY WALLS AND FLOORS SHALL BE CUT FLUSH AT THE SURFACE FOR PATCHING BY OTHERS. ALL CIRCUIT BREAKERS ASSOCIATED WITH THE DEMOLITION SCOPE SHALL BE DE-ENERGIZED AND LABELED SPARE.
4. ALL REMOVED ITEMS SHALL BE LEGALLY DISPOSED OF UNLESS IDENTIFIED FOR REUSE. THE OWNER'S REPRESENTATIVE SHALL INSPECT ALL RETAINED ITEMS PRIOR TO PLACEMENT IN THE IDENTIFIED STORAGE LOCATION BY THE ELECTRICAL CONTRACTOR.
5. REMOVED FLUORESCENT AND HID LAMPS AND BATTERIES SHALL BE RECYCLED BY A FACILITY APPROVED BY THE OWNER'S REPRESENTATIVE. A UNIFORM HAZARDOUS WASTE MANIFEST SHALL BE PREPARED FOR ALL DISPOSALS AND RETURNED WITH ALL APPLICABLE SIGN OFF'S PRIOR TO APPLICATION FOR FINAL PAYMENT.
6. ALL BALLAST IN LIGHTING FIXTURES TO BE DISPOSED SHALL BE VERIFIED TO BE PCB FREE. ALL BALLAST MANUFACTURED PRIOR TO 1979 AND NOT LABELED AS PCB FREE SHALL BE CONSIDERED TO CONTAIN PCBs. PROVIDE WRITTEN VERIFICATION TO THE OWNER'S REPRESENTATIVE THAT CONFIRMS PCB FREE WASTE, WHERE PCB FREE WASTE CANNOT BE VERIFIED. BALLAST SHALL BE RECYCLED BY A FACILITY APPROVED BY THE OWNER'S REPRESENTATIVE, WITH PCB COMPONENTS ELIMINATED BY A HIGH TEMPERATURE INCINERATION. A UNIFORM HAZARDOUS WASTE MANIFEST SHALL BE PREPARED FOR ALL DISPOSALS AND RETURNED WITH ALL APPLICABLE SIGN OFF'S PRIOR TO APPLICATION FOR FINAL PAYMENT. ALL HANDLING SHALL CONFORM TO EPA REQUIREMENTS. PROVIDE BREAKOUT COST FOR THIS SCOPE.

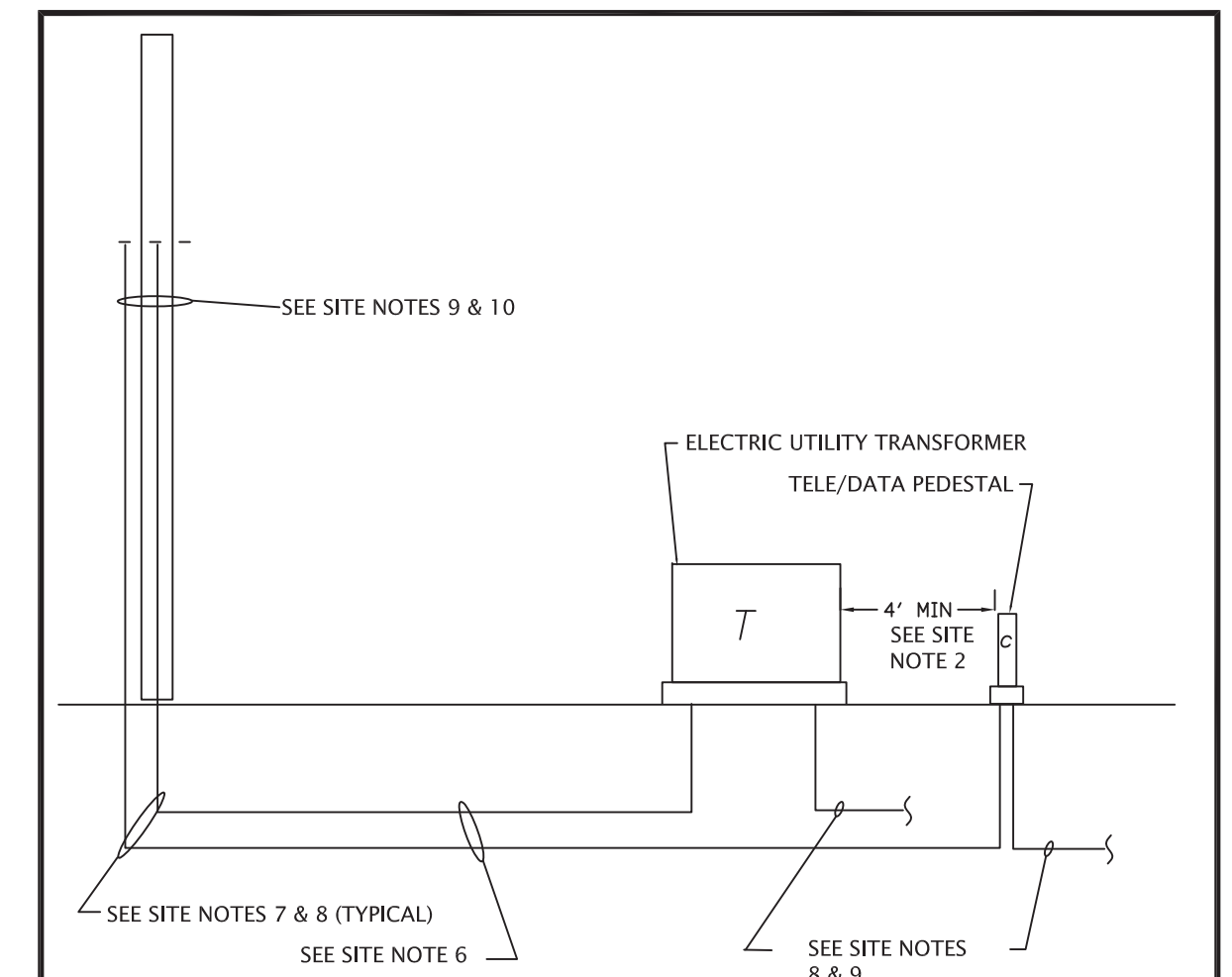

**1 EIA** Scale: None

**SITE NOTES:**

1. NEW TRANSFORMERS SHALL BE PROVIDED BY ELECTRICAL UTILITY. ELECTRICAL CONTRACTOR SHALL INSTALL TRANSFORMER PADS IN ACCORDANCE WITH THE UTILITY'S "REQUIREMENTS FOR ELECTRICAL CONNECTIONS" MANUAL. VERIFY FINAL TRANSFORMER LOCATIONS WITH UTILITY COMPANY.
2. NEW TELE/DATA PEDESTAL SHALL BE PROVIDED BY TELEPHONE/INTERNET COMPANY. ELECTRICAL CONTRACTOR SHALL INSTALL EMPTY CONDUIT TO LOCATION OF THE PEDESTAL. PEDESTAL LOCATION SHALL BE A MINIMUM OF 4 FEET FROM TRANSFORMERS TO ENSURE ADEQUATE SERVICE ACCESS TO TRANSFORMERS. VERIFY FINAL PEDESTAL LOCATION WITH TELEPHONE/INTERNET COMPANY.
3. NOT USED.
4. ELECTRICAL CONTRACTOR SHALL COORDINATE INSTALLATION OF DUCT BANKS WITH LOCATION OF NEW AND EXISTING SERVICES, SUCH AS WATER LINES, GAS LINES, DRAINAGE, ETC. REFER TO CIVIL ENGINEERING DRAWINGS FOR LOCATIONS OF THOSE SERVICES.
5. REFER TO THE UTILITY COMPANY'S "REQUIREMENTS FOR ELECTRICAL CONNECTIONS" MANUAL FOR THE LATEST REQUIREMENTS, INFORMATION IN THE UTILITY COMPANY'S MANUAL SHALL TAKE PRECEDENCE OVER INFORMATION LISTED ON THE ELECTRICAL DRAWINGS.
6. ALL UNDERGROUND CONDUITS SHALL BE PVC SCHEDULE 80 OR RIGID GALVANIZED STEEL.
7. CONDUIT SWEEPS FOR TELEPHONE AND CABLE SERVICES SHALL BE PVC SCHEDULE 40 IF DISTANCE BETWEEN SWEEPS IS LESS THAN 250 FEET. IF DISTANCE BETWEEN SWEEPS IS EQUAL TO OR GREATER THAN 250 FEET, THEN SWEEPS SHALL BE RIGID GALVANIZED STEEL.
8. CONDUIT SWEEPS FOR ELECTRIC UTILITY SERVICES SHALL BE RIGID GALVANIZED STEEL. REFER TO THE ELECTRIC UTILITY "REQUIREMENTS FOR ELECTRICAL CONNECTIONS" MANUAL FOR REQUIREMENTS.
9. FOR TELEPHONE/INTERNET SERVICES, TOP OF RISER CONDUITS SHALL BE A MINIMUM OF 10 FEET ABOVE FINISHED GRADE. ATTACH CONDUITS TO UTILITY POLE. DO NOT USE STAND OFF'S.
10. FOR ELECTRIC UTILITY SERVICE, RISER CONDUITS SHALL BE INSTALLED IN ACCORDANCE WITH THE ELECTRIC UTILITY "REQUIREMENTS FOR ELECTRICAL CONNECTIONS" MANUAL.

**McHENRY ARCHITECTURE**  
 4 Market Street  
 Portsmouth, New Hampshire  
 603.430.0274

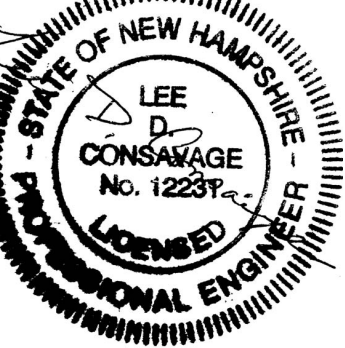

**SCE** Seacoast Consulting Engineers, LLC

261 Jennie Lane  
 Portsmouth, NH 03803  
 207-376-7230  
 www.SeacoastEngineers.com

Designed By: LDC  
 Drawn By: MBW  
 Checked By: LDC

Phone No. 2012-107  
 As Noted  
 03-09-2012

**Pavilion Building  
 Prescott Park  
 Portsmouth, NH**

Specifications, Scope of Work,  
 Utility Services Riser Diagram

**E1A**

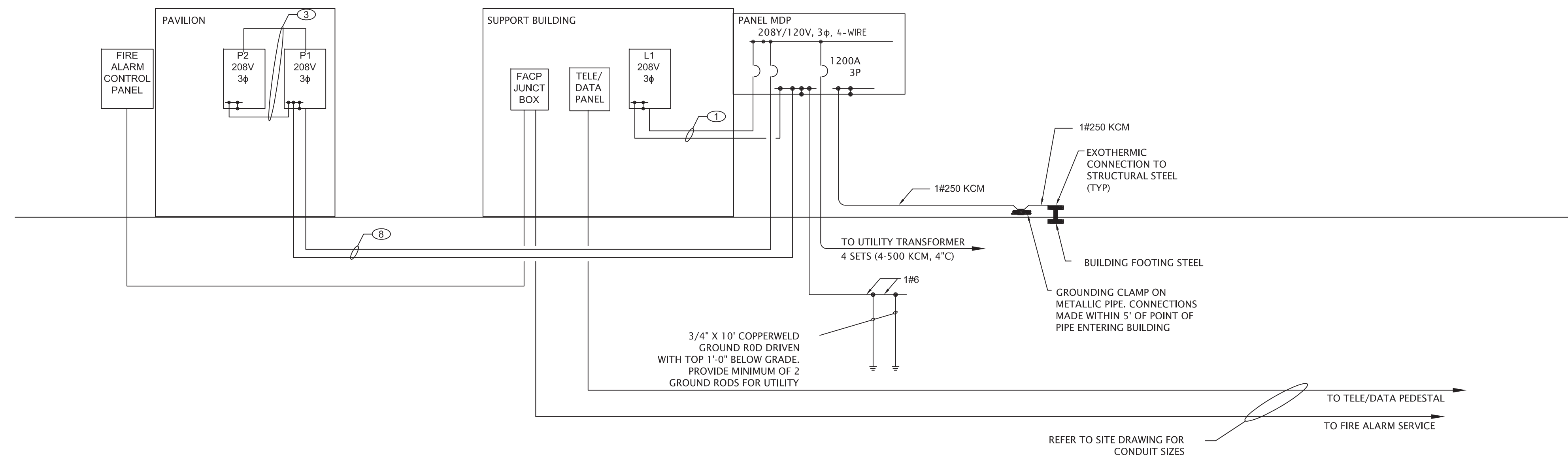

**1 Power & Data Riser Diagram**  
E-2 Scale: None

LEGEND OF FEEDER CONDUCTORS (COPPER CONDUCTORS ONLY)			
FEEDER SYMBOL	CONDUCTORS (3 PHASE, 4 WIRE, THWN-THHN & GROUNDING WIRE)	RACEWAY SIZE	AMPS
①	4#6 & 1#10 G.	1 1/4"	60
②	4#4 & 1#8 G.	1 1/4"	70
③	4#2 & 1#8 G.	1 1/2"	100
④	4#1 & 1#6 G.	2"	125
⑤	4#1/0 & 1#6 G.	2"	150
⑥	4#2/0 & 1#6 G.	2"	175
⑦	4#3/0 & 1#6 G.	2"	200
⑧	4#4/0 & 1#4 G.	2 1/2"	225
⑨	4-250 KCM & 1#4 G.	3"	250
⑩	4-350 KCM & 1#4 G.	3"	300
⑪	4-500 KCM & 1#3 G.	3 1/2"	350
⑫	2 SETS (4#3/0 & 1#6 G.)	2 - 2"	400

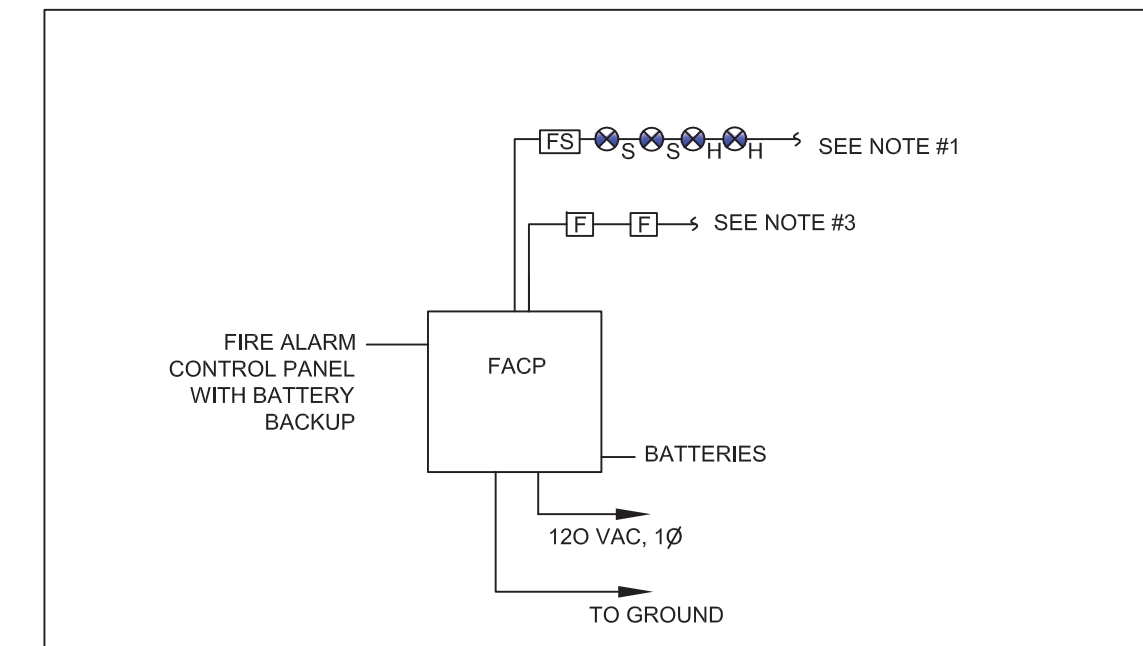

**FIRE ALARM SYSTEM NOTES:**

- CONNECT TO REMAINING DEVICES ON DATA CABLE LOOP IN ACCORDANCE WITH EQUIPMENT SUPPLIER'S APPROVED POINT TO POINT AND DEVICE ADDRESS DIAGRAMS.
- NOT USED.
- CONNECT TO REMAINING FIRE ALARM SIGNAL DEVICES IN ACCORDANCE WITH EQUIPMENT SUPPLIER'S APPROVED POINT TO POINT WIRING DIAGRAMS. PROVIDE TWO CIRCUITS EACH FOR AUDIO/VISUAL SIGNALS PER FLOOR. SIGNALS SHALL BE ALTERNATELY WIRED.
- MINIMUM SIZE CONDUIT SHALL BE 3/4" UNLESS OTHERWISE NOTED.
- SYSTEM WIRING SHALL BE INSTALLED IN ACCORDANCE WITH EQUIPMENT SUPPLIER'S APPROVED SHOP DRAWINGS AND WIRING DIAGRAM.
- CEILING MOUNTED SMOKE DETECTORS SHALL NOT BE LOCATED CLOSER THAN 3 FT. FROM ANY AIR SUPPLY DIFFUSERS.
- REFER TO FLOOR PLANS FOR QUANTITIES AND LOCATIONS OF SYSTEM DEVICES AND EQUIPMENT.

**3 Typical Fire Alarm Riser Diagram**  
E-2 Scale: None

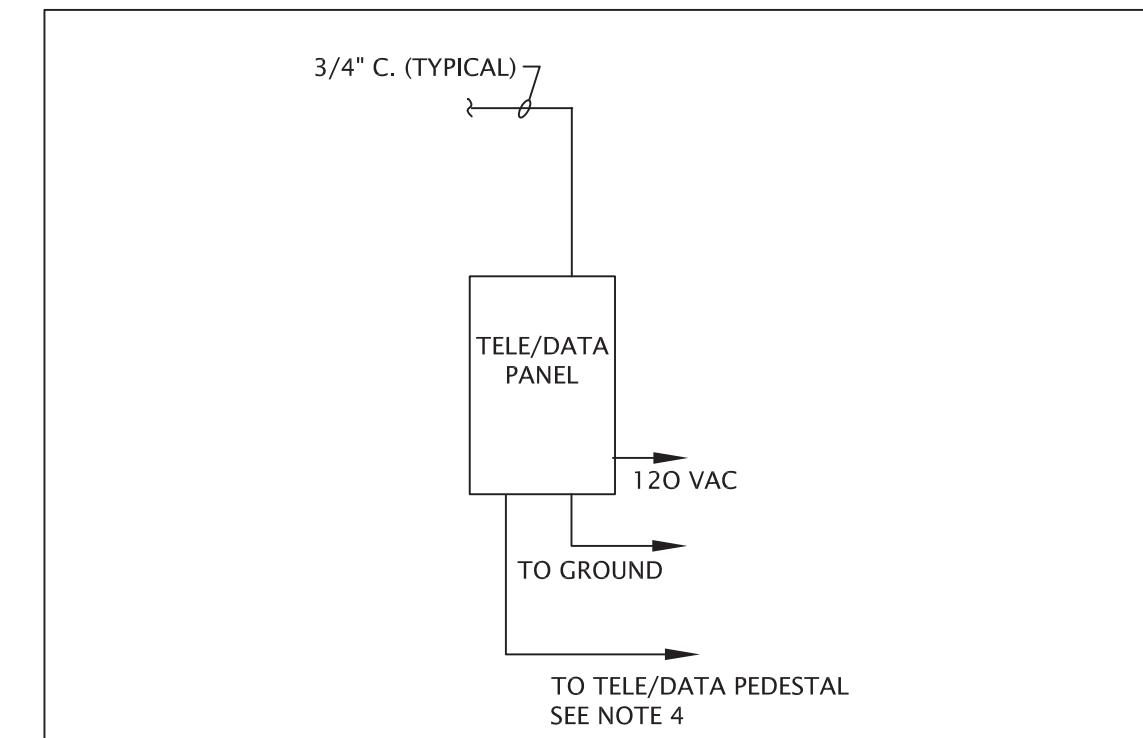

**TELEPHONE/DATA SYSTEM NOTES:**

- TELEPHONE/DATA SYSTEM COMPONENTS PROVIDED BY TELEPHONE/DATA SYSTEM CONTRACTOR. REFER TO FLOOR PLAN FOR LOCATION OF COMPONENTS.
- ELECTRICAL CONTRACTOR SHALL COORDINATE EMPTY CONDUIT LOCATIONS WITH LOCATION OF TELEPHONE/DATA SYSTEM COMPONENTS.
- PROVIDE PULL CORD IN EACH EMPTY CONDUIT.
- REFER TO SITE PLAN FOR CONDUIT SIZE.

**2 Typical Cable TV/Tele/Data Riser Diagram**  
E-2 Scale: None

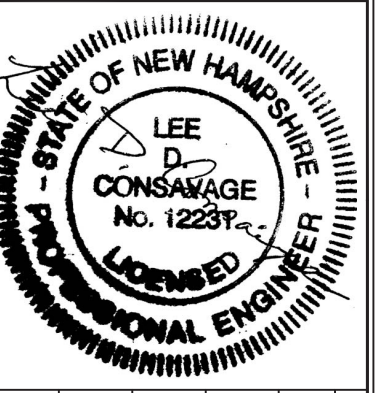





SCHEDULE

Item No	Qty	Equipment Category
1	1	Wire Shelving Unit, NSF
2	1	Wire Shelves, NSF
3	1	Wire Shelving Unit, NSF
4	1	FRYER FILTER, MOBILE
5	1	2 DR FREEZER, REACH IN
6	1	3 DR REFRIGERATOR REACH IN
7	2	OVERSHELF, WALL MOUNTED
8	1	WORK TABLE, 30"
9	1	CHEST FREEZER
10	1	JANITOR'S MOP SERVICE BASIN
11	1	FAUCET, SERVICE SINK
12	2	OVERSHELF, WALL MOUNTED
13	1	WIRE SHELVING
14	1	SPARE NUMBER
15	1	SINK, THREE COMPARTMENT
16	1	PRE-RINSE UNIT
17	1	SPARE NUMBER
18	1	SPARE NUMBER
19	1	SINK, ONE COMPARTMENT
20	2	FAUCET
21	2	OVERSHELF, WALL-MOUNTED
22	1	HANDSINK WALL MNTD W/SPLSH GROS
23	2	ICE MAKER, CUBE-STYLE
24	1	ICE BIN
25	1	EXHAUST HOOD & FIRE SYSTEM
26	1	SPARE NUMBER
27	1	HOTPLATE, COUNTER UNIT, GAS
28	1	REFRIGERATED CHEF'S BASE
29	1	GRIDDLE, COUNTER UNIT, GAS
30	3	FRYER, FLOOR MODEL, GAS, FULL POT
31	1	FRENCH FRY WARMER, BIN TYPE
32	1	HOLDING BIN, HEATED
33	1	FREEZER COUNTER, WORK TOP 4'
34	1	PIZZA OVEN
35	1	REFRIGERATED 4' SANDWICH TOP
36	1	OVERSHELF, TABLE MOUNTED
37	1	SHELF, PASS-THRU
38	1	EQUIPMENT STAND
39	1	FREEZER ICE CREAM MERCHANDISER
40	2	COUNTER TOP DISPLAY (CHIPS/CANDY)
41	1	WINDOW SRVC LAMINATE COUNTER 25'
42	2	REFRIGERATED DRINK DISPLAY U/C
43	3	CASH REGISTER
45	1	FREEZER, UNDERCOUNTER, REACH-IN
46	1	DISPLAY CASE, PRETZELS COUNTERTOP
47	1	MICROWAVE OVEN
48/49	1	HOT DOG GRILL & RETHERM DRAWER
50	1	HOD DOG ROLL WARMER
51	1	EQUIPMENT STAND 30"
52	1	COTTON CANDY FLOSS MACHINE
53	2	HAND SINK NARROW W/SIDE SPLASH
54	1	EQUIPMENT STAND, 4'
55	1	PARAGON THEATER POPCORN POPPER
56	1	DIPLAY CASE PIZZA, COUNTERTOP
57	2	REFRIGERATED DISPLAY CASE CNTRTOP
58	1	BACK BAR CABINET 9' LAMINATED
59	1	BAG IN BOX/SYRUP TANK RACK
60	1	CARBONATOR
61	1	SODA, ICE & BEVERAGE DISPENSER
62	1	AIRPOT SERVING RACK
63	1	AIR POT COFFEE BREWER
64	1	FLAVOR RAIL DIPPING CABINET
65	1	SPADEWELL ICE DIPPER STATION
66	1	SORTING SHELF
67	1	SOILED DISH TABLE WITH SINK
68	1	PRE-RINSE BASKET
69	1	PRE-RINSE UNIT
70	1	DISH MACHINE, PASS THROUGH
71	1	HOOD, CONDENSATE - 42"x42"
72	1	CLEAN DISH TABLE
73	2	WALL SHELF

POWER NOTES:  
 1. ELECTRICAL CONTRACTOR SHALL PROVIDE EF-2, WHICH IS A COMBINATION EXHAUST FAN & LIGHT. WIRE TO SAME SWITCH.

\* The layouts for Women's Room #104 and Men's Room #106 have been updated and Unisex Bathroom #108 has been added since the Mechanical, Electrical, and Plumbing Drawings were originally issued. Refer to Architectural Sheet A1 for updated layout and fixture counts. Please account for Unisex Bathroom #108 receiving the same treatment as Women's Room #104 and Men's Room #106 for such items as power supply, lighting, fire alarm, ventilation, water supply, drainage, etc.

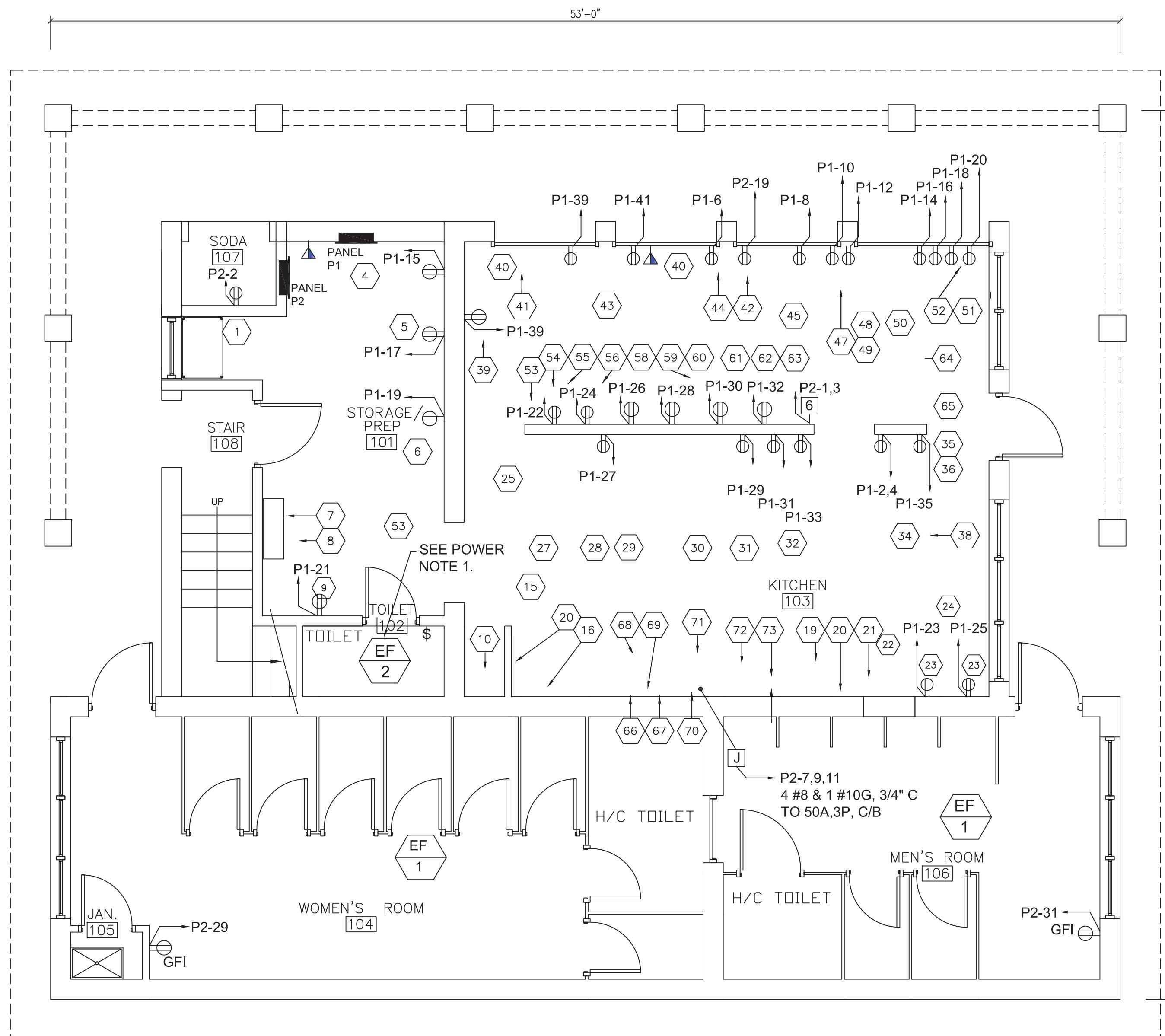

1 Pavilion 1st Floor Plan - Power & Tele/Data  
 E4 Scale: 1/4" = 1'

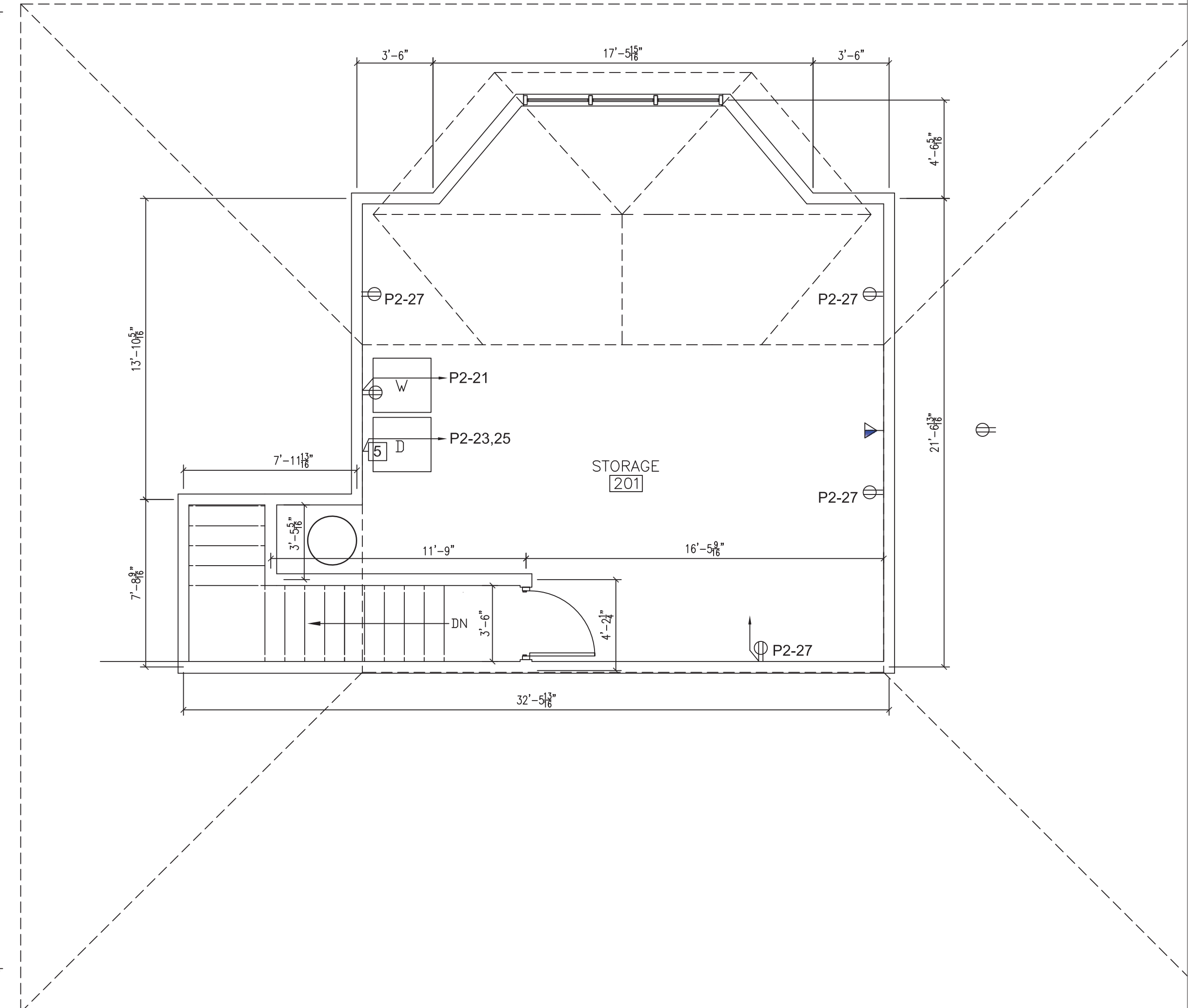

2 Pavilion 2nd Floor Plan - Power & Tele/Data  
 E4 Scale: 1/4" = 1'

Permit Set 03-16-2012

McHENRY  
 ARCHITECTURE  
 4 Market Street  
 Portsmouth, NH 03801  
 603.430.0274

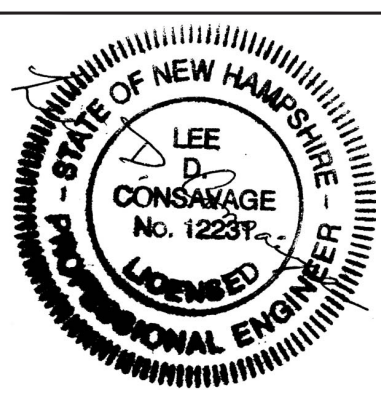

Seacoast Consulting  
 Engineers, LLC  
 SCE

261 Atlantic Lane  
 E04 Marine 03903  
 207-370-7230  
 www.SeacoastEngineers.com  
 Project No. 2012-107  
 Scale As Noted  
 03-09-2012

Pavilion Building  
 Prescott Park  
 Portsmouth, NH  
 Pavilion 1st & 2nd Floor Plans -  
 Power & Tele/Data

E4

LIGHTING NOTE:  
 1. ELECTRICAL CONTRACTOR SHALL PROVIDE EF-2, WHICH IS  
 A COMBINATION EXHAUST FAN & LIGHT. WIRE TO SAME  
 SWITCH.

\* The layouts for Women's Room #104 and Men's Room #106 have been updated and Unisex Bathroom #108 has been added since the  
 Mechanical, Electrical, and Plumbing Drawings were originally issued. Refer to Architectural Sheet A1 for updated layout and fixture counts.  
 Please account for Unisex Bathroom #108 receiving the same treatment as Women's Room #104 and Men's Room #106 for such items as  
 power supply, lighting, fire alarm, ventilation, water supply, drainage, etc.

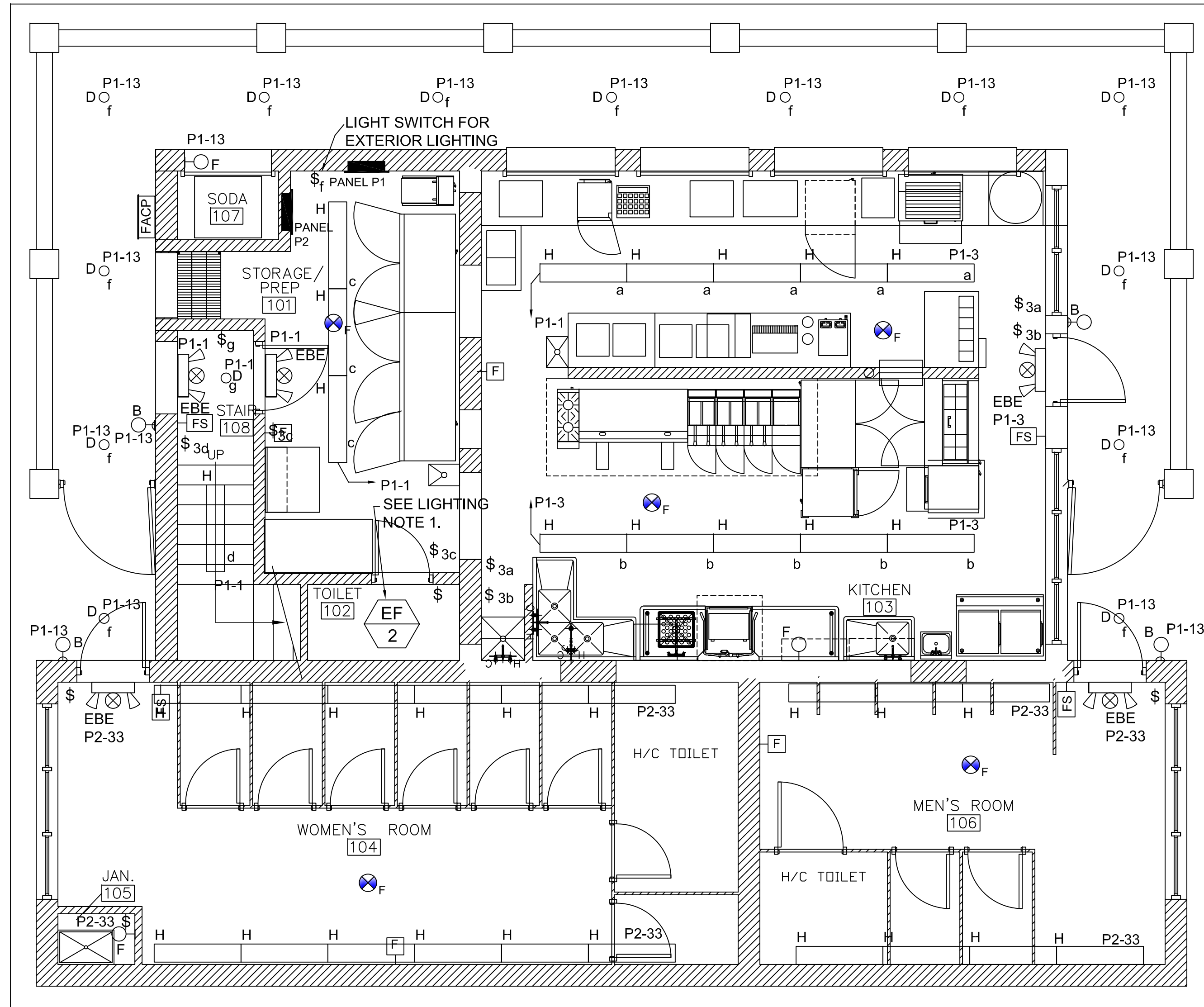

1 Pavilion 1st Floor Plan - Fire Alarm  
 E7 Scale: 1/4" = 1'

1 1st Floor Reflected Ceiling Plan - Lighting  
 E5 Scale: 1/4" = 1'

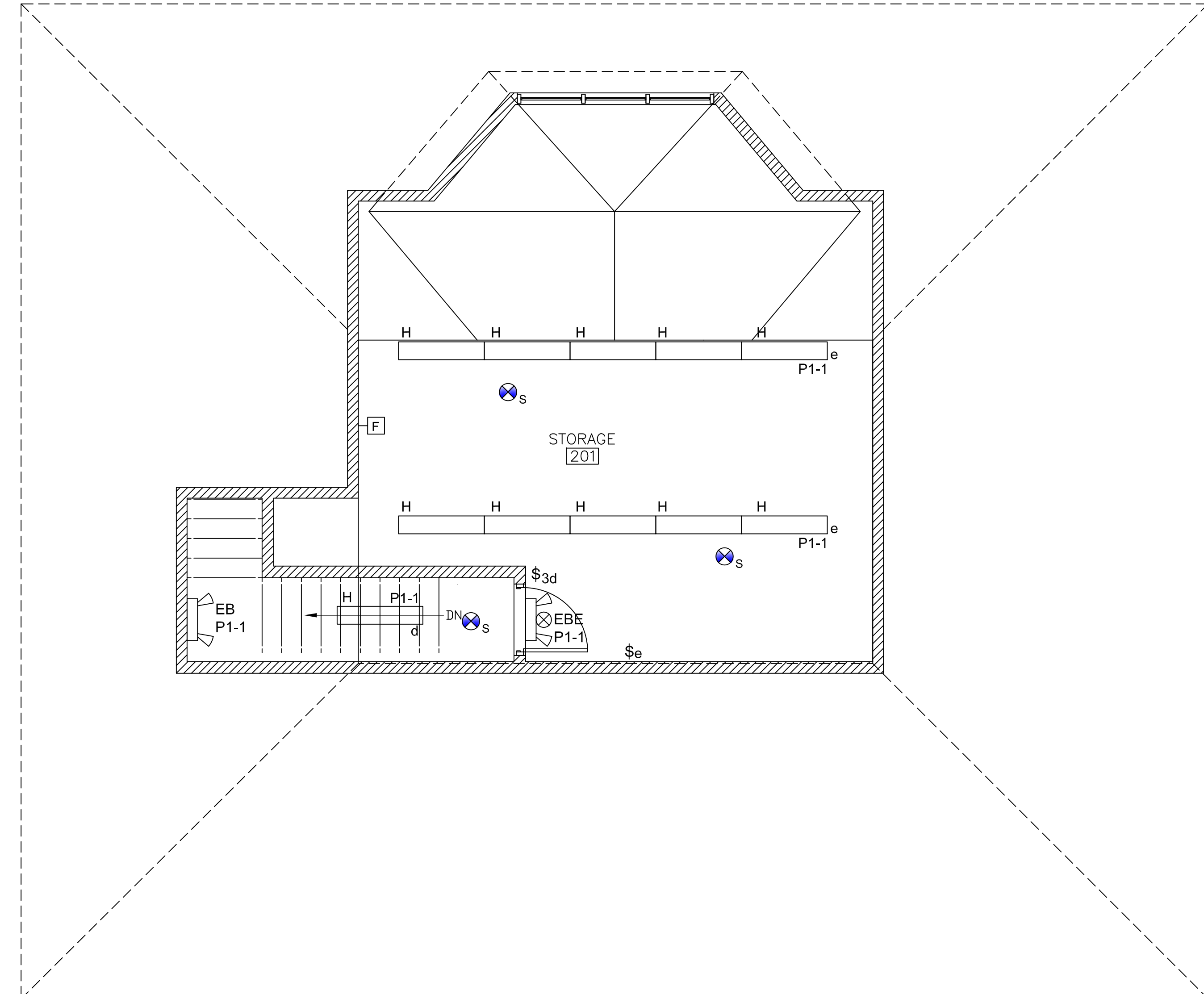

2 Pavilion 2nd Floor Plan - Fire Alarm  
 E7 Scale: 1/4" = 1'

2 2nd Floor Reflected Ceiling Plan - Lighting  
 E5 Scale: 1/4" = 1'



Seacoast Consulting  
 Engineers, LLC  
 SCE  
 261 Jennie Lane  
 Eliot, Maine 03903  
 207-370-7230  
 www.SeacoastEngineers.com  
 Project No. 2012-107  
 Scale As Noted  
 Date 03-09-2012  
 Designed By: LDC  
 Drawn By: MWK  
 Checked By: LDC

Pavilion Building  
 Prescott Park  
 Portsmouth, NH  
 1st & 2nd Floor - RCP - Lighting

E5

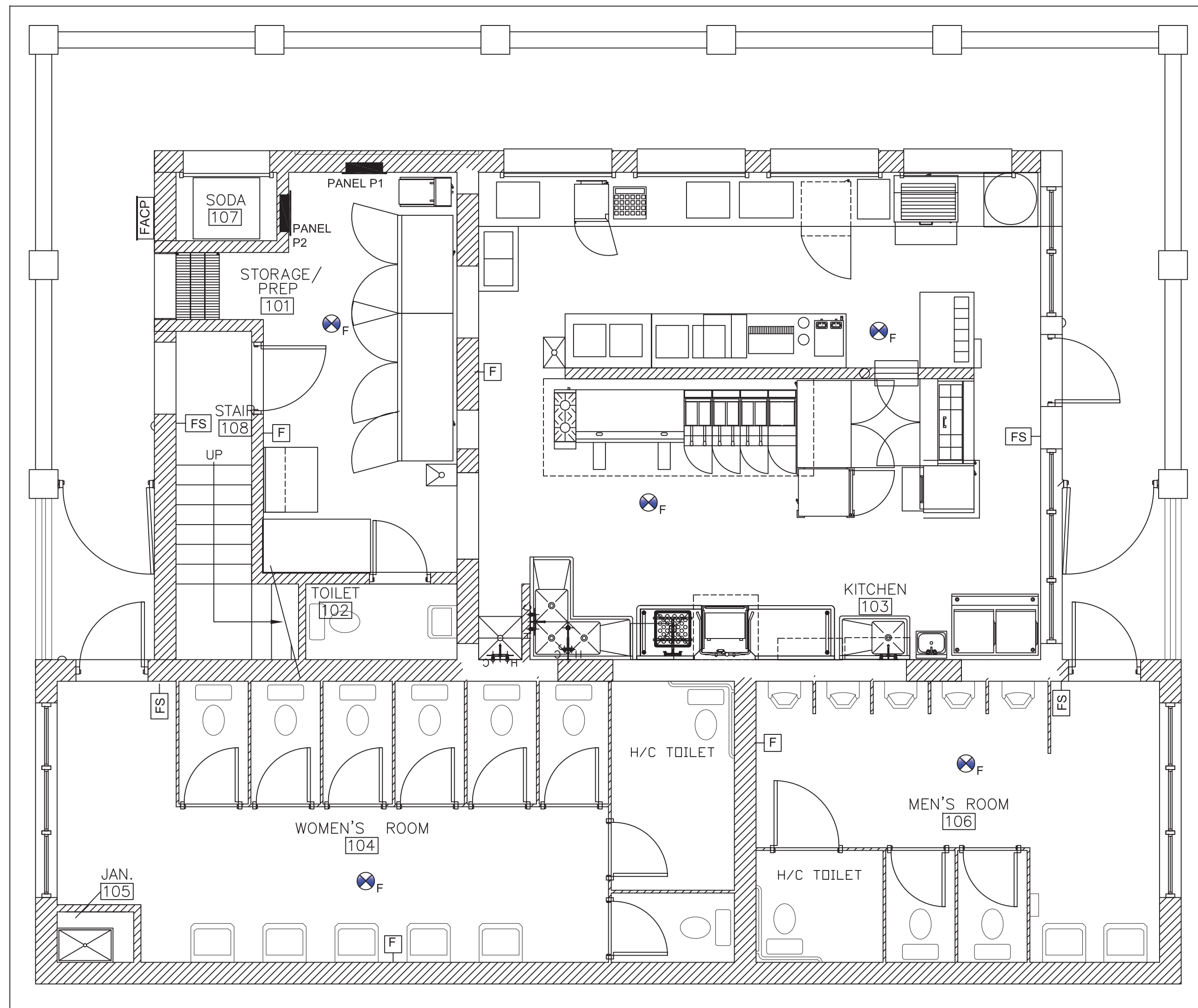

1 Pavilion 1st Floor Plan - Fire Alarm  
 E7 Scale: 1/4" = 1'

\* The layouts for Women's Room #104 and Men's Room #106 have been updated and Unisex Bathroom #108 has been added since the Mechanical, Electrical, and Plumbing Drawings were originally issued. Refer to Architectural Sheet A1 for updated layout and fixture counts. Please account for Unisex Bathroom #108 receiving the same treatment as Women's Room #104 and Men's Room #106 for such items as power supply, lighting, fire alarm, ventilation, water supply, drainage, etc.

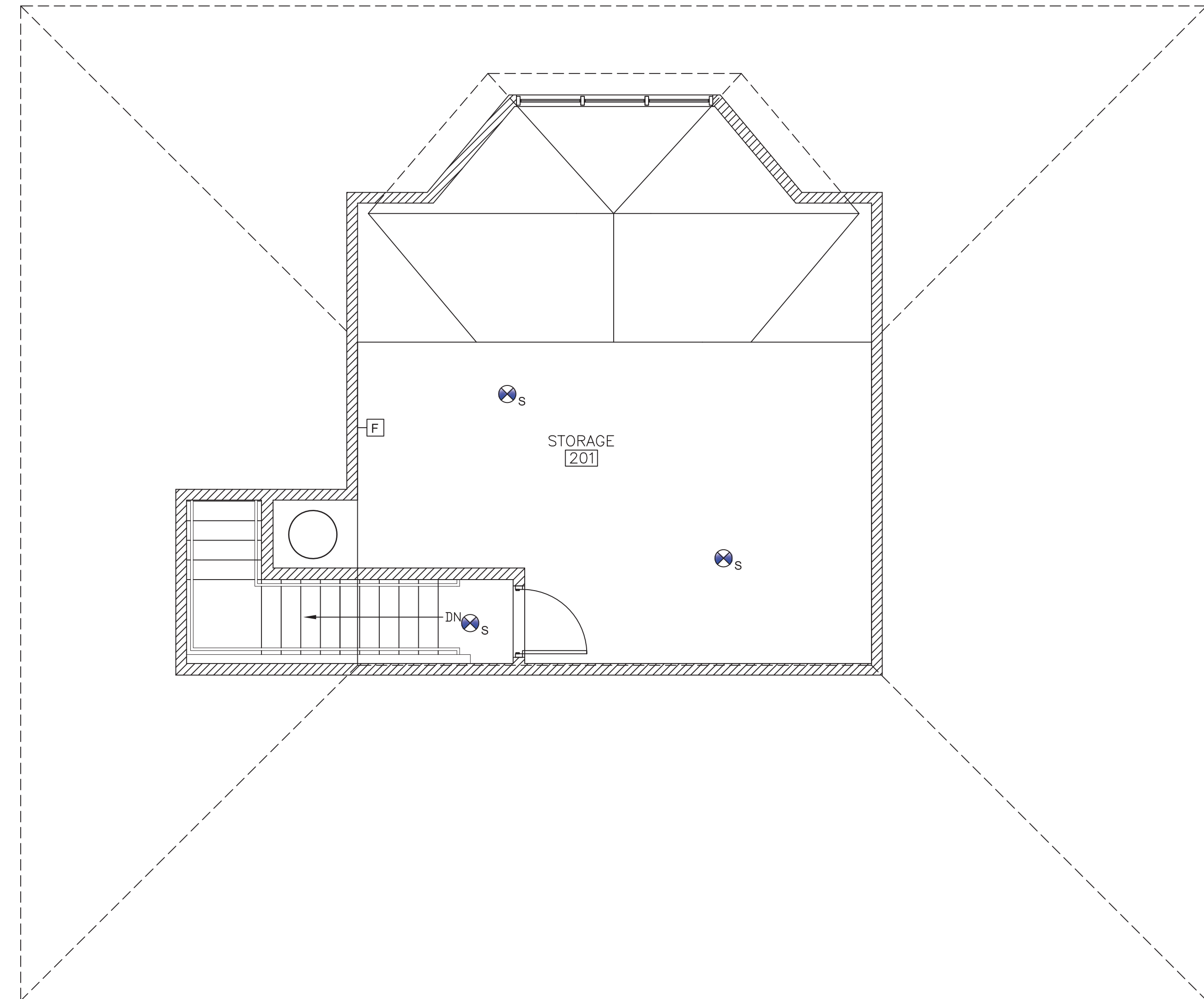

2 Pavilion 2nd Floor Plan - Fire Alarm  
 E7 Scale: 1/4" = 1'

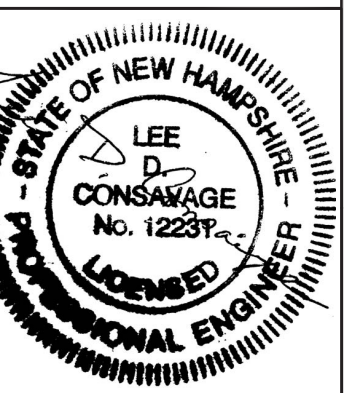

Seacoast Consulting  
 Engineers, LLC  
 261 Jennie Lane  
 Eliot, Maine 03903  
 207-370-7230  
 www.SeacoastEngineers.com  
 Project No. 2012-107

Designed By: LDC  
 Drawn By: MFK  
 Checked By: LDC  
 Date: 03-09-2012

SCALE: As Noted

**Pavilion Building  
 Prescott Park  
 Portsmouth, NH**

Support Building Plan & Pavilion - Fire Alarm

**E7**



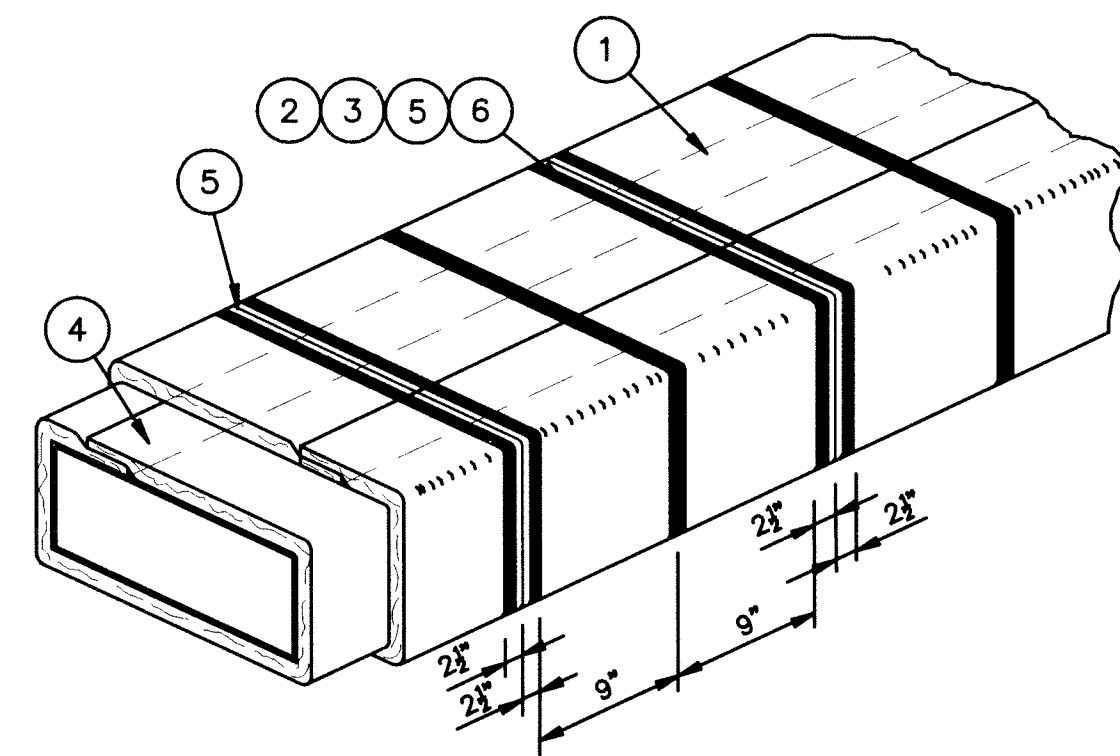

**INSTALLATION METHOD:**

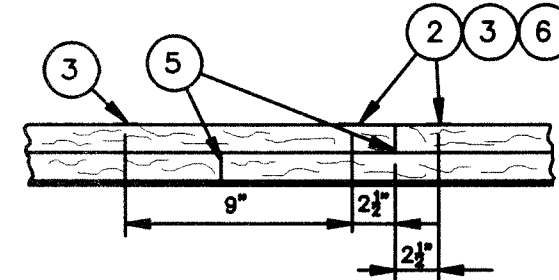

**Butt-Joint  
Adjacent Blanket Pieces**

Legend	
1	FyreWrap Elite 1.5 Duct Insulation, Two Layers (each 1 1/2", total thickness = 3")
2	Filament Tape (Temporary Hold)
3	1/8" Carbon or SS Bonding Straps (Permanent Hold)
4	2" Minimum Longitudinal Overlap
5	1" Compressed Butt Joint
6	3" Wide Aluminum Foil Tape at End Layer Butt Joints

**KITCHEN EXHAUST DUCT INSULATION DETAIL**

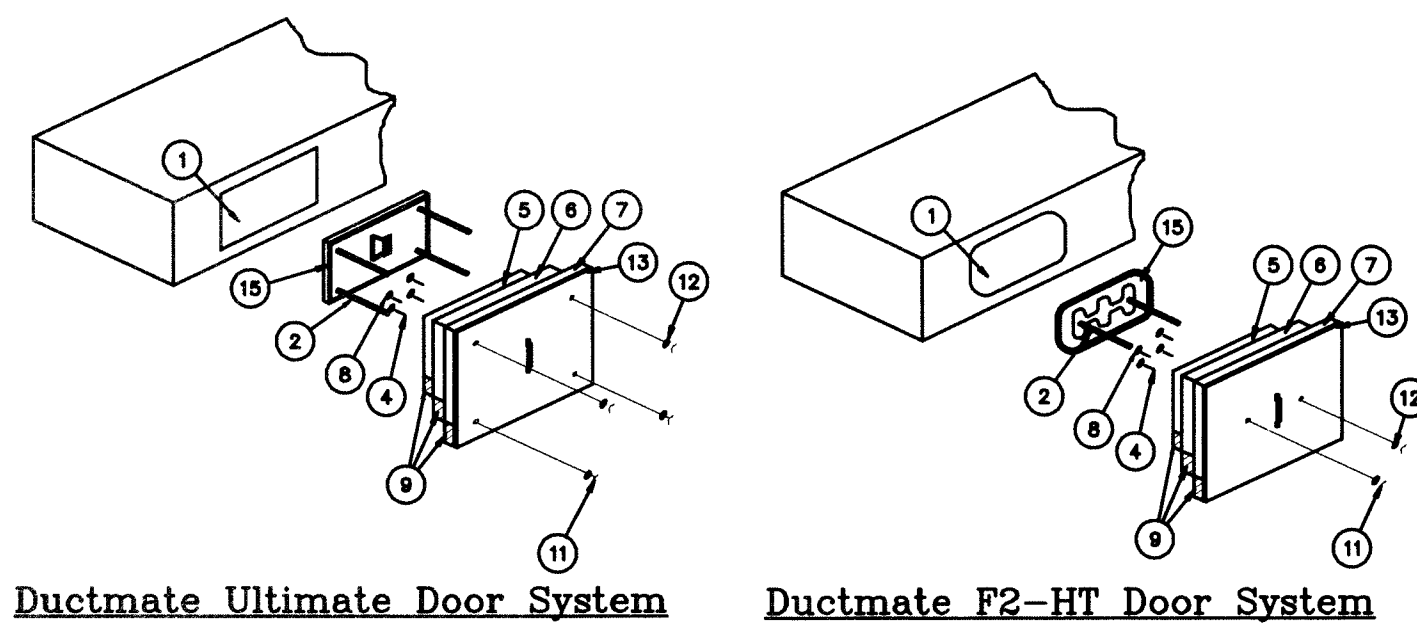

**Ductmate Ultimate Door System**

**Ductmate F2-HT Door System**

Legend	
1	Access Door Opening
2	All Thread Rods
3	Access Door Cover Panel 16 Gauge (field fab. only)
4	Insulation Pins - Welded to Cover
5	First Layer FyreWrap Elite 1.5
6	Second Layer FyreWrap Elite 1.5, 1" Overlap
7	Third Layer FyreWrap Elite 1.5, 1" Overlap
8	Speed Clips/Washers
9	Out Edges Sealed With Aluminum Foil Tape
10	Spud pieces for threaded rods (optional field fab. only)
11	Wing Nuts
12	Washers
13	Insulation plate
14	Ceramic fiber gasket, 1" thick
15	Pre-fabricated access door

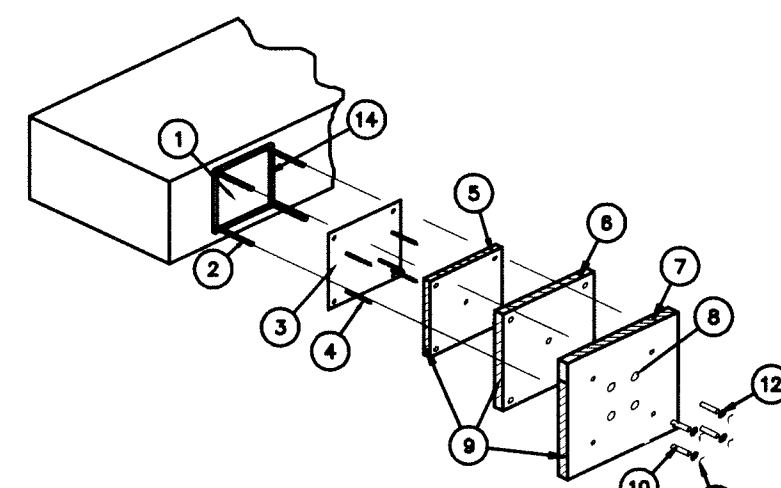

**Field Fabricated Door System**

**KITCHEN EXHAUST DUCT ACCESS DETAIL**

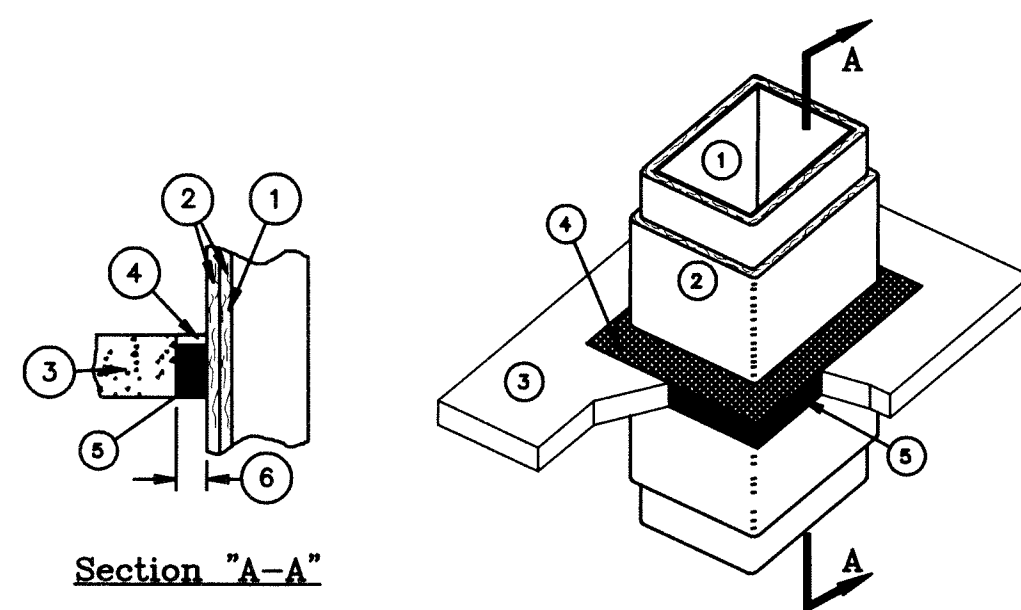

**Section "A-A"**

Legend	
1	Drains Duct, max. 2400mm diam, 40" max width
2	FyreWrap Elite 1.5 Duct Insulation, Two Layers
3	Fyre-Resistive Floor assembly
4	FyreWrap Sealant, 1" depth, overlapping on floor and duct min. 1" on fire barrier (100psi or 180 PSI-OR or 200 Specified OR or Tenno FyreWR)
5	Unbonded FyreWrap Elite 1.5 or 4 PCF Mineral Wool compressed 100% recessed 1" from top side of floor
6	Firestop, 1" to 2"

**KITCHEN EXHAUST DUCT PENETRATION DETAIL**

**EXHAUST FAN SCHEDULE**

UNIT NO.	MANUFACTURER MODEL / NUMBER	SERVICE	CFM	FAN TYPE	(IN. WG) E.S.P.	ELECTRICAL	REMARKS
TX-1 #2	GREENHECK G-185	WMN / MEN BATHROOM	600	CENTRIFUGAL	0.375	115/1/60	ROOF MOUNTED DIRECT DRIVE W/ CURB & DAMPER
TX-3	PANASONIC FV-08VKL3 WhisperGreen Lite	KITCHEN BATHROOM	75	FANLIGHT	0.375	115/1/60	FAN/LITE BATH EXH FAN TO BE WIRED BY ELEC CONTR INSTALLED AND DUCTED BY MECH CONTR
EF-1	PROVIDED BY KITCHEN SUPPLIER	DISHWASHER EXHAUST	700	CENTRIFUGAL	0.50	115/1/60	SUPPLIED BY KITCHEN EQUIP SUPPLIER INSTALLED BY MECHANICAL CONTRACTOR
KEF-1	PROVIDED BY KITCHEN SUPPLIER	KITCHEN HOOD EXH FAN	6000	UPBLAST	0.75	TBD	SUPPLIED BY KITCHEN EQUIP SUPPLIER - SIZED TO BE CONFIRMED - INSTALLED BY MECH CONTRACTOR

\*Refer to Architectural Sheet A1 for updated Bathroom layouts and fixture counts.

**REGISTER, GRILLE & DIFFUSER SCHEDULE**

MARK	MAKE	* MODEL	NECK SIZE	APPLICATION	REMARKS
1 CFM	TITUS	350 FL	8x8	CEILING/WALL RETURN	GWB CEILING
2 CFM	TITUS	350 FL	18x12	CEILING/WALL RETURN	GWB CEILING

**Captive-Aire Model TYPE 2 HOOD SYSTEM**

New one (1) Condensate (vapor removal) Hood system complete w/ wall flashing, liquid tight sealed duct, exhaust fan & controls

- 1 ea New 100% #304 s/s condensate hood 42" x 42" w/ full perimeter gutter & factory installed exhaust riser
- 1 ea One (1) 700 CFM model DU30HFA High Speed direct drive centrifugal upblast exhaust fan. To include gasketing, Flat Curb #CRB19.5X22E w/ hinged base 120/60/1-Phase/4.0AMPS/1/4 HP/DIRECT (3 wire)
- 1 ea liquid tight ductwork sections (1 @ 59"L, 1 @ 47"L, 2 @ 29"L) 3 support bracket assembly, 14 duct "V" clamps, 1 duct-to-curb transition piece, adjustable duct, duct set-off collar, 3M duct fire barrier.
- 1 ea Install & hang exhaust hood, fan, curbing & run all ductwork & accessories in compliance with all national & local codes.

	VOLTS	CYCLE (HZ)	PHASE	CONN	AFF	NEMA	AMPS	KW	HP	MCA	MOCP
ELECTRICAL	120	60	1	Direct			4.0		1/4		

**ELECTRICAL REMARKS**

Direct wire - 3 wire connection

**DISHWASHER INFO FROM SUPPLIER**

**Item 25 - EXHAUST HOOD & FIRE SYSTEM (1 REQ'D)**

Alternative/Hoods & fire suppression Model CAPTIVE AIRE

Provide one (1) New 13'L x 4'W x 2'H Exhaust only Box-canopy type s/s hood w/ s/s rear-wall skirting, w/exhaust fans & 20" liquid tight ductwork, roof curbs & a water-wash based CORE Fire suppression system to meet UL-300 & NFPA 96 Standards w/ hood cabinet & pre-piped/pre-wired controls.

NOTE #1: The above base price is for an exhaust only Hood (no make-up air) w/ top & side insulation for zero clearance installation from combustible surfaces & finished s/s back & right side wall skirting, exhaust fan(s), duct work, roof curbs & controls, and includes the set-up of the fire suppression system. (Final connection to water by plumber)

Note #2: Our delivery & installation work shall be limited to bringing the hood and its components to the site, hanging the hood, installing the back & side wall skirting, connecting the duct work and installing the duct work to the exhaust fans.

Note #3: Our scope of work does not include any plumbing, gas fitting, electric (or fire alarm work), carpentry, masonry, roofing or HVAC work that may be required to prepare the job site for a hood/fire suppression system delivery & installation. Our scope of work does not require lifting the exhaust fans, roof curbs or duct work to the roof. If fans need to be installed on a roof the owner shall provide a crane to move fans there, or locate the fans there by other means. Additionally, our scope of work does not include the provision of any licensed engineer services and/or engineered stamped drawings, plans or affidavits. Services not included in our scope of work may be provided at additional costs to be determined.

NOTE #4: Any/all licensed trades work (plumbing, gas fitting, electrical, carpentry, roofing/masonry, HVAC, etc.) required for the proper installation of this hood shall be by others.

**KITCHEN HOOD & EXHAUST NOTES FROM SUPPLIER**

**VENTILATING SPECIFICATIONS**

PERFORM THE WORK INCLUDED IN THIS PROJECT SCOPE IN ACCORDANCE WITH 2009 INTERNATIONAL MECHANICAL CODE (IMC), INTERNATIONAL ENERGY CONSERVATION CODE (IECC), PORTSMOUTH AMENDMENTS, LOCAL CODES AND REGULATIONS.

COORDINATE INSTALLATION OF EQUIPMENT WITH EXISTING ARCHITECTURAL, STRUCTURAL, PLUMBING AND ELECTRICAL SYSTEMS.

PROVIDE SUBMITTALS OF FANS, CURBS, DAMPERS, ROOF VENTS, DUCTWORK, INSULATION, SUPPORTS AND HANGERS FOR APPROVAL.

INSTALL DUCTWORK, EQUIPMENT AND ACCESSORIES AFTER COORDINATION HAS BEEN REVIEWED AND APPROVED BY THE ARCHITECT.

COORDINATE ALL DUCT RUNS AND PENETRATION LOCATIONS WITH OTHER TRADES TO ENSURE PROPER CLEARANCES ARE MADE TO ELECTRICAL DEVICES AND EQUIPMENT. PROVIDE REQUIRED CLEARANCES FOR MAINTENANCE.

COORDINATE CUTTING AND/OR DRILLING THROUGH STRUCTURAL MEMBERS WITH THE PROJECT MANAGER PRIOR TO COMMENCING WORK.

REMOVE DEBRIS AND CONSTRUCTION WASTE FROM WORK AREAS ON A CONTINUAL BASIS. DO NOT ALLOW DEBRIS AND CONSTRUCTION WASTE TO ACCUMULATE ON SITE. REMOVE AND TRANSPORT DEBRIS IN A MANNER WHICH WILL PREVENT SPILLAGE ON ADJACENT SURFACES AND AREAS. REMOVE DEBRIS FROM ELEVATED PORTIONS OF THE BUILDING BY CHUTE, HOIST OR OTHER DEVIE THAT WILL CONVEY DEBRIS TO GRADE LEVEL IN A CONTROLLED DESCENT.

DO NOT BURN REMOVED MATERIALS.

TRANSPORT REMOVED MATERIALS OFF SITE AND LEGALLY DISPOSE OF THEM.

STORAGE OR SALE OF REMOVED ITEMS OR MATERIALS ON-SITE IS NOT PERMITTED.

**KITCHEN EXHAUST SYSTEM:**

THE KITCHEN SUPPLIER WILL BE SUPPLYING THE HOOD, DUCTWORK AND EXHAUST FAN FOR INSTALLATION BY THE MECHANICAL CONTRACTOR. THESE PLANS SHOW PROPOSED DUCT DETAILS AND SIZES FOR PRICING AND PERMITTING. ONCE THE SIZES AND EQUIPMENT HAVE BEEN CONFIRMED REVISED PLANS AND DETAILS WILL BE SUBMITTED.

**DISHWASHER EXHAUST:**

INSTALL ALUMINUM DISHWASHER EXHAUST FROM THE FURNISHED DISHWASHER TO THE FURNISHED EXHAUST FAN. INSTALL VERTICALLY. IF OFFSETS NEED TO BE MAKE SLOPE DUCT A MINIMUM OF 1/4" PER FOOT BACK IN THE DIRECTION OF THE DISHWASHER HOOD.

**BATHROOM EXHAUST:**

PROVIDE BATHROOM EXHAUST AS INDICATED ON THE PLANS. THE CEILINGS ARE FLAT SHEETROCK. RUN DUCTWORK CONCEALED BEHIND CEILINGS AND WALLS TO MAXIMUM EXTEND POSSIBLE.

**HOT WATER HEATER COMBUSTION AIR:**  
INSTALL A ROOF MOUNTED GRAVITY VENTILATOR TO PROVIDE COMBUSTION AIR AS INDICATED ON THE PLANS. PROVIDE THE VENTILATOR WITH A 14" HIGH CURB WITH INSECT SCREEN. THE 12X12 COMBUSTION AIR DUCT IS TO DROP DOWN TO THE CEILING LEVEL WITH A FRAMED 1/4" X 1/4" EXPANDED ALUMINUM MESH.

THIS COMMUNICATION WITH THE OUTDOORS CAN ALSO ACT AS TRANSFER AIR FOR A SINGLE FUTURE TYPE 2 CLOTHES DRYER.

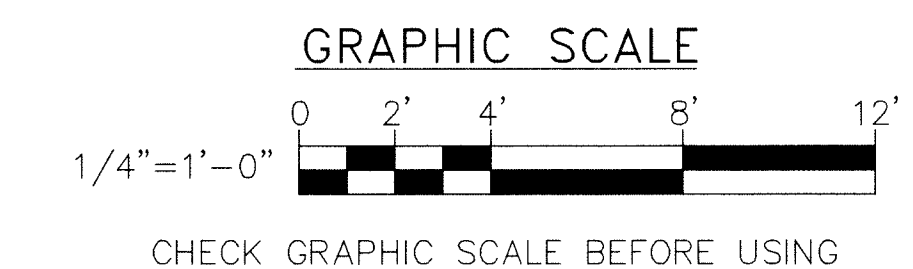

Permit Set, 03-16-2012

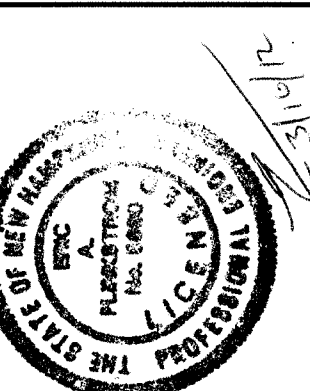

261 Jennie Lane  
Eliot, Maine 03903  
207-370-7230  
www.SeacoastEngineers.com

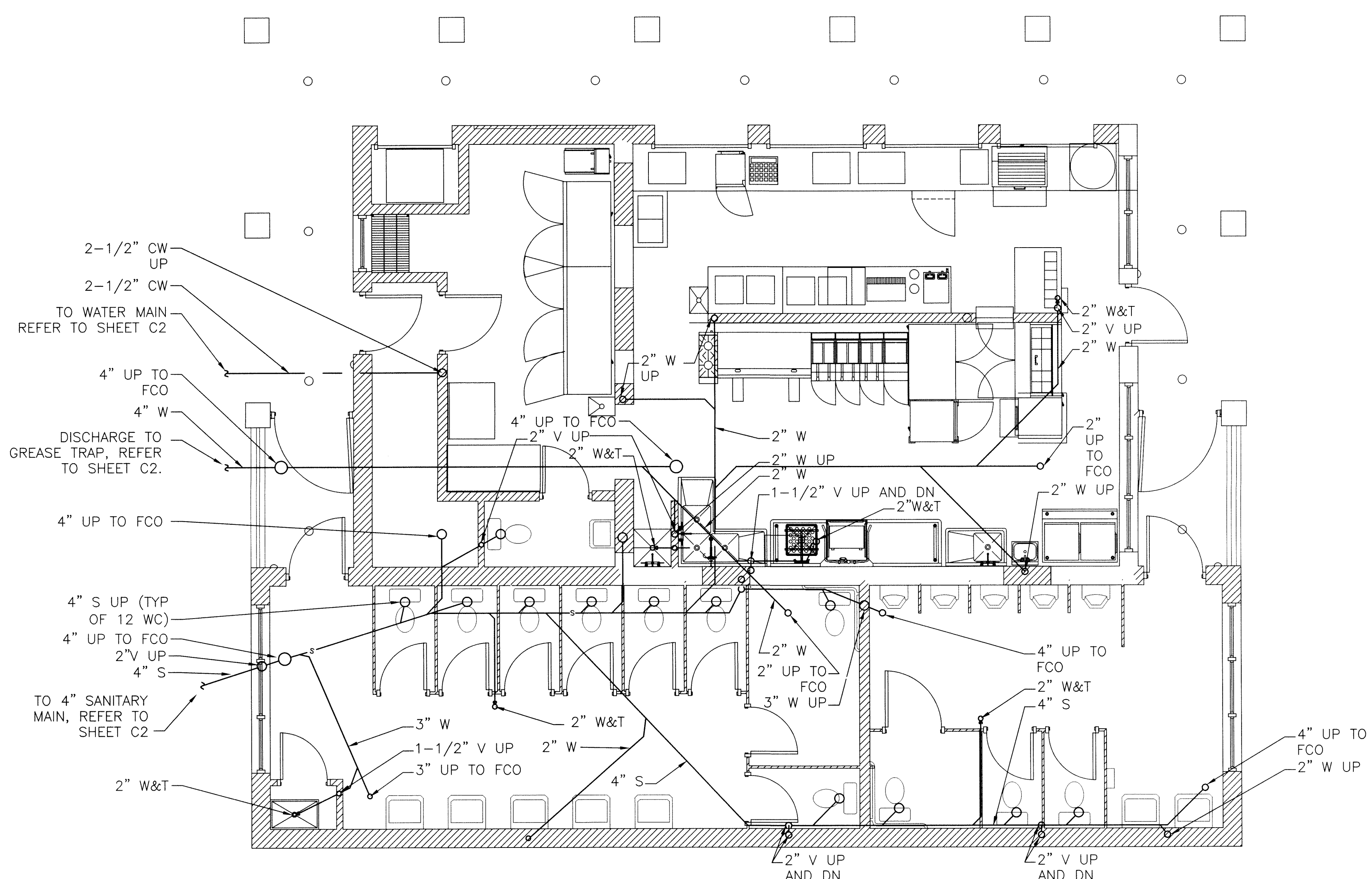
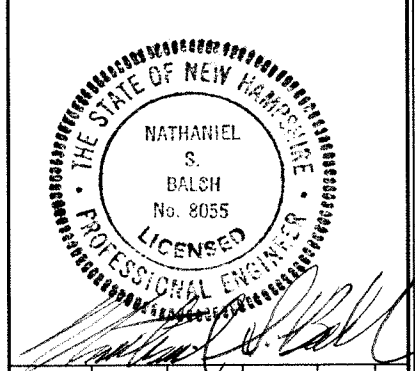

1 UNDERSLAB PIPING PLAN  
P1.1 SCALE: 1/4" = 1'-0"

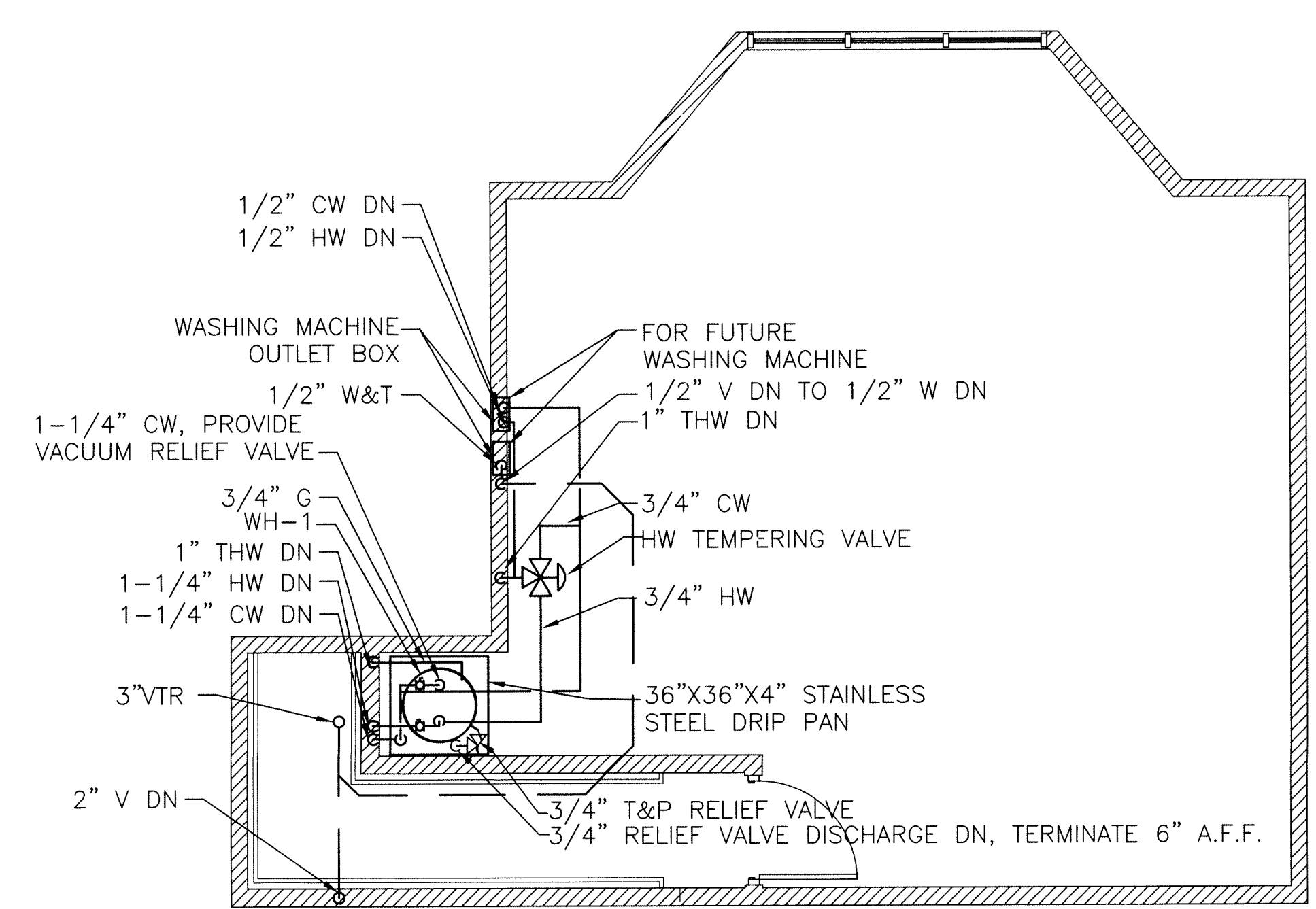

2 SECOND FLOOR PLUMBING PLAN  
P1.1 SCALE: 1/4" = 1'-0"

DRAWING NOTES  
1. REFER TO KITCHEN EQUIPMENT SCHEDULE FOR DESCRIPTIONS OF NUMBERED ITEMS.

\* The layouts for Women's Room #104 and Men's Room #106 have been updated and Unisex Bathroom #108 has been added since the Mechanical, Electrical, and Plumbing Drawings were originally issued. Refer to Architectural Sheet A1 for updated layout and fixture counts. Please account for Unisex Bathroom #108 receiving the same treatment as Women's Room #104 and Men's Room #106 for such items as power supply, lighting, fire alarm, ventilation, water supply, drainage, etc.

WATER HEATER SCHEDULE

UNIT NO.	STORAGE GAL	GAS INPUT MBH	RECOVERY AT 90° F RISE	GAS CONNECTION	WATER CONNECTIONS	BASIS OF DESIGN
WH-1	98	75.1	82	0.5"	1.25"	STATE SBS 100 76 NE
NOTES						

Seacoast Consulting Engineers, LLC  
 SCE  
 261 Jennie Lane  
 Eliot, Maine 03803  
 207-370-7230  
 www.SeacoastEngineers.com  
 Project No. 2012-107  
 Scale As Noted  
 03-09-2012  
 Designed By: NSB  
 Drawn By: MEW  
 Checked By: EAF  
 Date

Pavilion Building  
 Prescott Park  
 Portsmouth, NH  
 PLUMBING PLANS AND SCHEDULE

PLUMBING ABBREVIATIONS LEGEND	
AFF	ABOVE FINISHED FLOOR
AMP	AMPERES
CD	CONDENSATE DRAIN
C/L	CENTERLINE
CO	CLEANOUT
CW	DOMESTIC COLD WATER
DIA	DIAMETER
DN	DOWN
DW	DISHWASHER
FCO	FLOOR CLEANOUT
FT HD	FEET OF HEAD
G	GAS
GPM	GALLONS PER MINUTE
HP	HORSEPOWER
HW	HOT WATER
HZ	HERTZ
INV EL	INVERT ELEVATION
L	LAVATORY
NFWH	NON-FREEZE WALL HYDRANT
OED	OPEN END DRAIN
P	PUMP
RPM	REVOLUTIONS PER MINUTE
S	SANITARY SOIL, SINK
SH	SHOWER
THW	TEMPERED HOT WATER
TYP	TYPICAL
V	SANITARY VENT
V	VOLTS
W	SANITARY WASTE
W&T	WASTE AND TRAP
WC	WATER CLOSET
WH	WATER HEATER

PLUMBING SYMBOLS LEGEND	
	PIPE TURNING UP
	PIPE TURNING DOWN
	WASTE AND TRAP
	COUNTERTOP LAVATORY
	WALL HUNG LAVATORY
	SHOWER STALL
	TANK TYPE WATER CLOSET
	NON-FREEZE WALL HYDRANT
	PUMP
	BALL VALVE
	BATHTUB
	WATER METER
	UNION
	CHECK VALVE
	STRAINER

PLUMBING LINETYPE LEGEND	
	SANITARY SOIL PIPE
	BURIED SANITARY SOIL PIPE
	SANITARY WASTE PIPE
	BURIED SANITARY WASTE PIPE
	SANITARY VENT PIPE
	DOMESTIC COLD WATER PIPE
	DOMESTIC HOT WATER PIPE

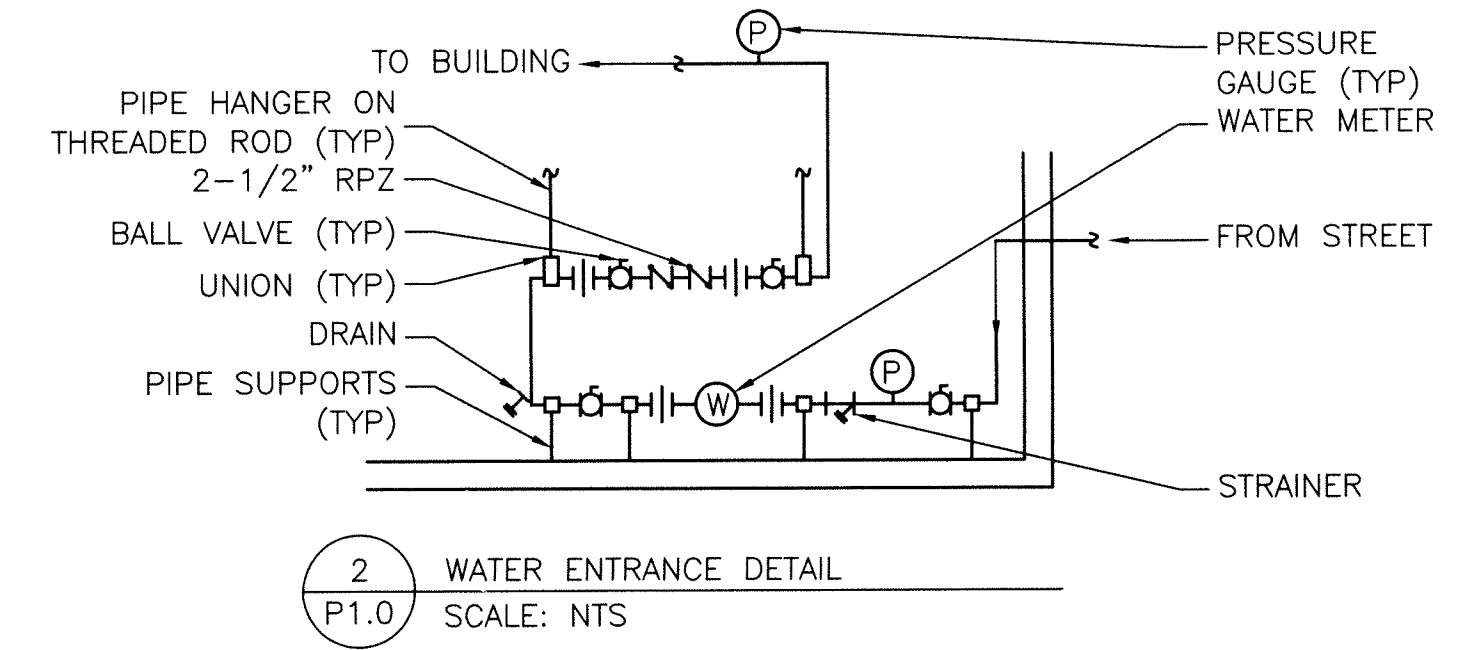
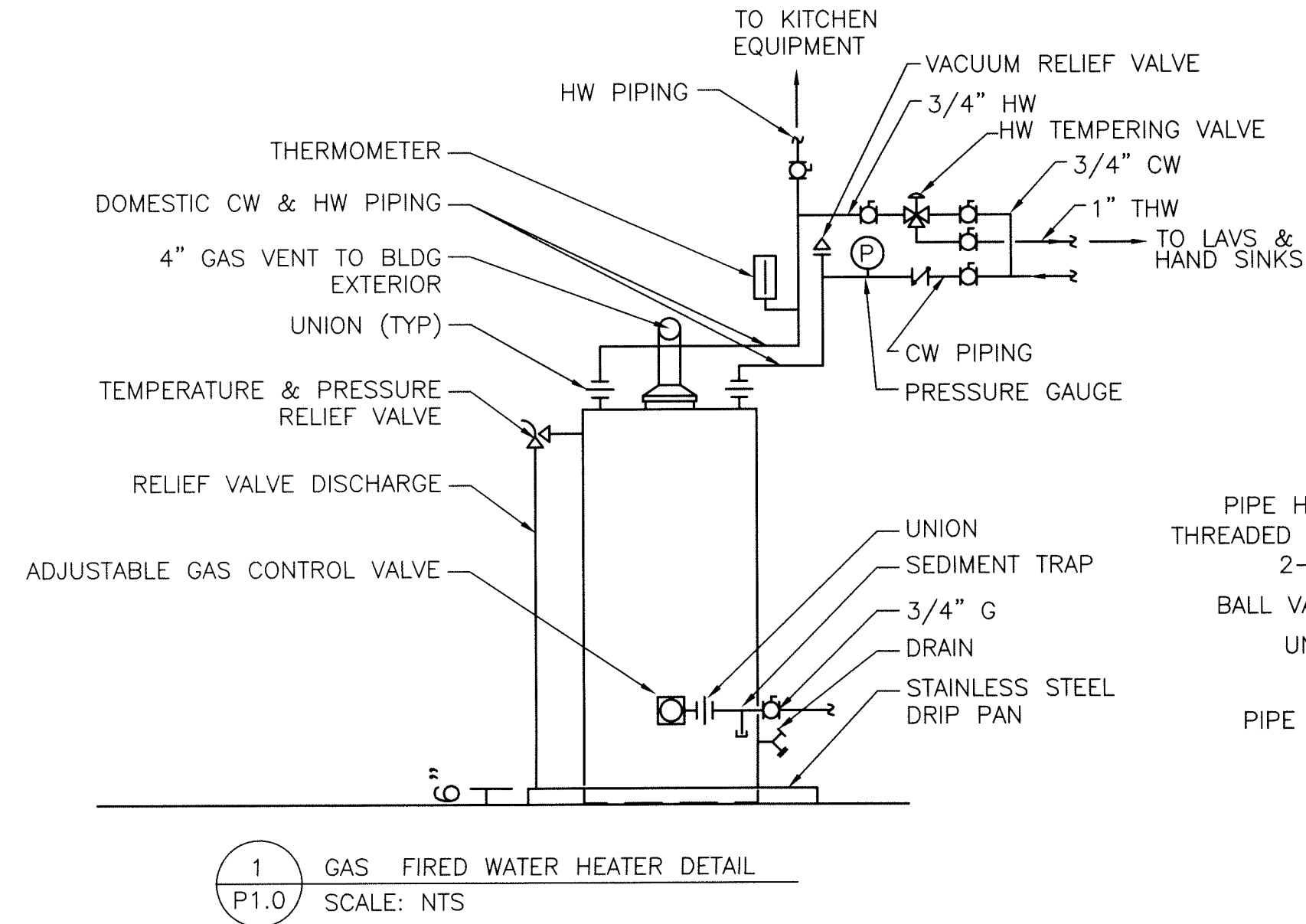

\* The layouts for Women's Room #104 and Men's Room #106 have been updated and Unisex Bathroom #108 has been added since the Mechanical, Electrical, and Plumbing Drawings were originally issued. Refer to Architectural Sheet A1 for updated layout and fixture counts. Please account for Unisex Bathroom #108 receiving the same treatment as Women's Room #104 and Men's Room #106 for such items as power supply, lighting, fire alarm, ventilation, water supply, drainage, etc.

PLUMBING FIXTURE ROUGH-IN SCHEDULE								
FIXTURE NO.	DESCRIPTION	CW	HW	W	S	V	BASIS OF DESIGN	NOTES
L-1	WALL-HUNG LAVATORY	1/2"	1/2"	1-1/2"	-	1-1/2"	AMERICAN STANDARD LUCERNE #0356.421	1,2
WC-1	WATER CLOSET	1"	-	-	4"	2"	AMERICAN STANDARD MADERA 1.28 GPF #2034.014	3
WC-2	WATER CLOSET	1"	-	-	4"	2"	AMERICAN STANDARD MADERA 1.28 GPF #2034.014	2,3
U-1	URINAL	3/4"	-	3"	-	1/2"	AMERICAN STANDARD WASHBROOK 0.5 GPF #6590.505	4
U-2	URINAL	3/4"	-	3"	-	1/2"	AMERICAN STANDARD WASHBROOK 0.5 GPF #6590.505	2,4
MR-1	MOP RECEPTOR	1/2"	1/2"	3"	-	1-1/2"	FIAT #TSB3003	5
FD-1	FLOOR DRAIN	-	-	2"	-	1-1/2"	J.R. SMITH #2005, ROUND GRATE.	
FD-2	FLOOR DRAIN	-	-	2"	-	1-1/2"	J.R. SMITH #2005, #F-37 RAISED RIM.	
NFWH	NON-FREEZE WALL HYDRANT	1/2"	-	-	-	-	J.R. SMITH #5609QT	6
NOTES	1. SINGLE CENTER, W/ CHICAGO #2200-E2805CP FAUCET 2. ADA COMPLIANT. 3. #6065.121.002 FLUSH VALVE, FLOOR OUTLET, #5901.100 OPEN-FRONT SEAT. 4. SLOAN #8189 FLUSH VALVE. 5. CHICAGO #305-VBRCF FAUCET, CAST BRASS P-TRAP. 6. INTEGRAL VACUUM BREAKER, FLUSH MOUNT, KEYPED VALVE.							

PLUMBING FIXTURE ROUGH-IN SCHEDULE								
FIXTURE NO.	DESCRIPTION	CW	HW	W	G	V	BASIS OF DESIGN PER KITCHEN CONSULTANT	NOTES
10	JANITOR'S MOP SINK	-	-	3"	-	1-1/2"	ALTERNATIVE SALES #63M	
11	SERVICE SINK FAUCET	1/2"	1/2"	-	-	-	FISHER #8253- INSTALL WITH ITEM #10	
15	3-COMPARTMENT SINK	-	-	1-1/2"	-	1-1/2"	TURBO AIR #TSA-3C-D1	
16	PRE-RINSE UNIT	1/2"	1/2"	-	-	-	FISHER #48917 INSTALL WITH ITEM #15	
19	1-COMPARTMENT SINK	-	-	1-1/2"	-	1-1/2"	TURBO AIR #TSA-1-D1	
20	FAUCET	1/2"	1/2"	-	-	-	FISHER #34916- INSTALL WITH ITEM #15 & ITEM #19	
22	HAND SINK	1/2"	1/2"	1-1/2"	-	1-1/2"	ALTERNATIVE SALES #HAND SINK	
23	ICE MAKER, CUBE STYLE	3/8"	-	3/4" NPT	-	-	SCOTSMAN #CO522SA-1B	1
24	ICE BIN	-	-	3/4" NPT	-	-	SCOTSMAN #B948S	1
27	GAS HOTPLATE	-	-	-	3/4"	-	TURBO #TAHP-12-2, 64 MBH	
29	COUNTERTOP GAS GRIDDLE	-	-	-	3/4"	-	AMERICAN RANGE #AETG-60, 150 MBH	
30	FREESTANDING GAS FRYER	-	-	-	3/4"	-	ANETS #SLG40, 90 MBH	3
53	HAND SINK/ FAUCET	1/2"	1/2"	1-1/2"	-	1-1/2"	BK RESOURCES #AS-BKHS-W-SS-SS-P BUNN-O-MATIC #AXION-APS-0013	2
63	COFFEE BREWER	3/8"	-	-	-	-	NEMCO #77316-19	1
65	ICE CREAM DIPPER STATION	3/8"	-	1"	-	-	ADVANCE TABCO #DTS-S70-36R-X	1
67	SOILED DISHTABLE	-	-	1-1/2"	-	1-1/2"	FISHER #29459	
69	PRE-RINSE UNIT	1/2"	1/2"	-	-	-	CHAMPION #DH-2000	1
70	DISHWASHER	-	3/4"	2"	-	-		
NOTES	1. INDIRECT WASTE. 2. PROVIDE #30200.1000 EQ-17-TL WATER FILTER. 3. THREE GAS FRYERS.							

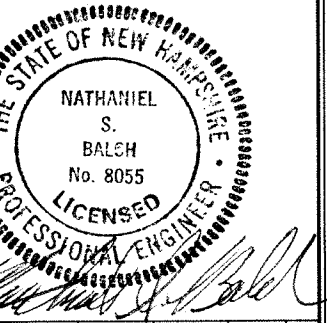

261 Jennie Lane  
Eliot, Maine 03903  
207-370-7230  
www.SeacoastEngineers.com

Designed By: NSB  
Drawn By: MRW  
Checked By: EBF  
Date: 03-09-2012

Project No. 2012-107 SCALE As Noted



\* The layouts for Women's Room #104 and Men's Room #106 have been updated and Unisex Bathroom #108 has been added since the Mechanical, Electrical, and Plumbing Drawings were originally issued. Refer to Architectural Sheet A1 for updated layout and fixture counts. Please account for Unisex Bathroom #108 receiving the same treatment as Women's Room #104 and Men's Room #106 for such items as power supply, lighting, fire alarm, ventilation, water supply, drainage, etc.

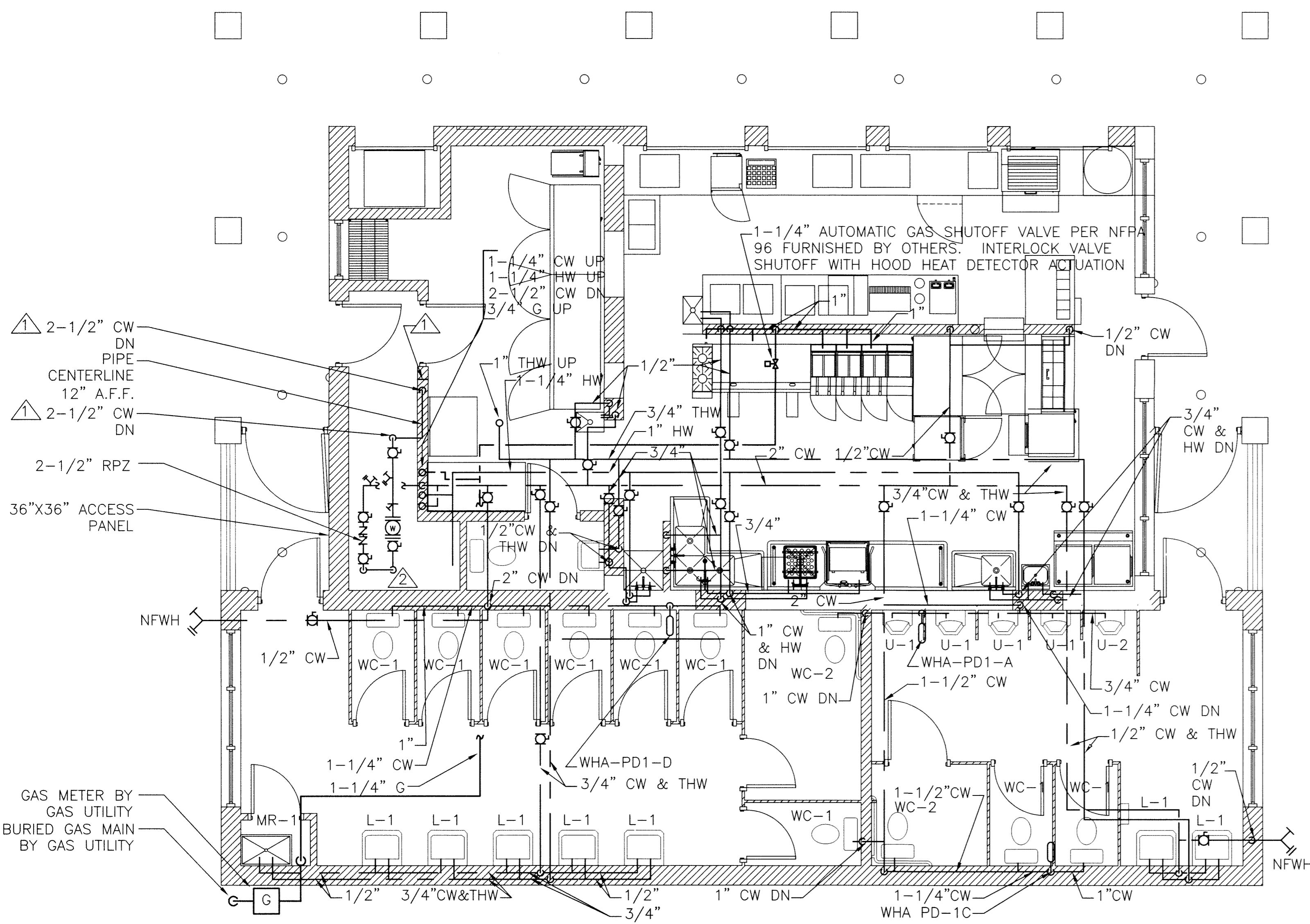

1 WATER AND GAS DISTRIBUTION PIPING PLAN  
 P1.2 SCALE: 1/4" = 1'-0"

**DRAWING NOTES**  
 1. REFER TO KITCHEN EQUIPMENT SCHEDULE FOR DESCRIPTIONS OF NUMBERED ITEMS.

**DRAWING KEYNOTES**  
 ▲ PROVIDE DRAIN VALVE IN RISER.  
 ▲ COORDINATE WITH CITY OF PORTSMOUTH WATER DEPT.

**PLUMBING SPECIFICATIONS**

PERFORM THE WORK INCLUDED IN THIS PROJECT SCOPE IN ACCORDANCE WITH 2009 INTERNATIONAL PLUMBING CODE (IPC), INTERNATIONAL ENERGY CONSERVATION CODE (IECC), INTERNATIONAL FUEL GAS CODE (IFGC), NEW HAMPSHIRE PLUMBING CODE, AND LOCAL CODES AND REGULATIONS.

PROVIDE PREMIUM EFFICIENCY EQUIPMENT, IN ACCORDANCE WITH IECC.  
 COORDINATE INSTALLATION OF EQUIPMENT WITH EXISTING ARCHITECTURAL, STRUCTURAL, MECHANICAL AND ELECTRICAL SYSTEMS.

PROVIDE SUBMITTALS OF WATER HEATER, PIPING, PIPE INSULATION AND PLUMBING FIXTURES FOR APPROVAL.

INSTALL PIPING, EQUIPMENT AND ACCESSORIES ABOVE CEILINGS AND BEHIND WALLS UNLESS SPECIFICALLY DIRECTED BY THE ARCHITECT.

PROVIDE SLEEVES FOR PIPING PASSING THROUGH WALLS, FLOORS AND CEILINGS. INNER DIAMETERS OF SLEEVES SHALL BE A MINIMUM OF 1/2 INCH LARGER THAN OUTER DIAMETER OF PIPES. PROVIDE SLEEVES SIZED TO ACCOMMODATE INSULATED PIPES.

PROVIDE CHROME-PLATED ESCUTCHEONS AT EXPOSED PIPE PENETRATIONS THROUGH WALLS.

DRAIN PAN: TYPE 304 STAINLESS STEEL SHEET, 16 GAUGE, WELDED SEAMS. AIRSTREAM SURFACES: ASHRAE 62.1-2007 COMPLIANCE.

PROVIDE EQUIPMENT AND FIXTURES INDICATED ON SCHEDULES OR EQUIPMENT WITH CONSTRUCTION AND PERFORMANCE EQUALING OR EXCEEDING EQUIPMENT SCHEDULED.

INSTALL SYSTEMS AS INDICATED ON THE DRAWINGS. DO NOT DEVIATE FROM THE ARRANGEMENTS SHOWN ON THE DRAWINGS WITHOUT PRIOR APPROVAL OF THE PROJECT MANAGER.

COORDINATE WORK TO BE PERFORMED IN EACH AREA WITH THE PROJECT MANAGER PRIOR TO COMMENCING WORK.

COORDINATE CUTTING AND/OR DRILLING THROUGH STRUCTURAL MEMBERS WITH THE PROJECT MANAGER PRIOR TO COMMENCING WORK.

REMOVE DEBRIS AND CONSTRUCTION WASTE FROM WORK AREAS ON A CONTINUAL BASIS. DO NOT ALLOW DEBRIS AND CONSTRUCTION WASTE TO ACCUMULATE ON SITE. REMOVE AND TRANSPORT DEBRIS IN A MANNER WHICH WILL PREVENT SPILLAGE ON ADJACENT SURFACES AND AREAS. REMOVE DEBRIS FROM ELEVATED PORTIONS OF THE BUILDING BY CHUTE, HOIST OR OTHER DEVICE THAT WILL CONVEY DEBRIS TO GRADE LEVEL IN A CONTROLLED DESCENT.

DO NOT BURN REMOVED MATERIALS.  
 TRANSPORT REMOVED MATERIALS OFF SITE AND LEGALLY DISPOSE OF THEM.

STORAGE OR SALE OF REMOVED ITEMS OR MATERIALS ON-SITE IS NOT PERMITTED.

**WATER SUPPLY PIPE AND FITTINGS:**

ABOVEGROUND DOMESTIC WATER SUPPLY PIPING: DRAWN-TEMPER COPPER TUBING, ASTM B88, TYPE L, WROUGHT-COPPER FITTINGS, ASME B16.22.

BELOWGROUND DOMESTIC WATER SUPPLY PIPING: ANNEALED-TEMPER COPPER TUBING, ASTM B88, TYPE K.

DRAIN PIPING: DRAWN-TEMPER COPPER TUBING, ASTM B306, TYPE DW.

**JOINING MATERIALS:**

SOLDER FILLER METALS: ASTM B32, LEAD-FREE ALLOYS, WASHABLE FLUX.  
 BRAZING METAL: COPPER-PHOSPHORUS BRAZING METAL, AWS A5.8.

**JOINING METHODS:**

SOLDERED JOINTS: APPLY ASTM B813, WATER-FLUSHABLE FLUX, UNLESS OTHERWISE INDICATED, TO TUBE END. CONSTRUCT JOINTS USING LEAD-FREE SOLDER ACCORDING TO ASTM B238 OR 'COPPER TUBE HANDBOOK' PUBLISHED BY THE COPPER DEVELOPMENT ASSOCIATION (CDA).

BRAZING: CONSTRUCT JOINTS ACCORDING TO "BRAZING HANDBOOK" PUBLISHED BY THE AMERICAN WELDING SOCIETY (AWS), USING COPPER-PHOSPHORUS BRAZING METAL COMPLYING WITH AWS A 5.8.

**SANITARY WASTE AND VENT PIPING:**

BELOW GROUND: HUB AND SPIGOT CAST IRON PIPING, ASTM A74, WITH COMPRESSION GASKETS.  
 ABOVE GROUND: HUB AND SPIGOT CAST IRON PIPING, ASTM A74, WITH COMPRESSION GASKETS OR HUBLESS, ASTM A888, WITH NO-HUB COUPLINGS AND THREE-BAND CLAMPS.

**GAS PIPE AND FITTINGS:**

BLACK STEEL PIPE, ASTM A53 SCHEDULE 40, THREADED ENDS WITH ASME B16.3 CLASS 150 MALLEABLE THREADED FITTINGS.

**PLUMBING SPECIFICATIONS (CONTINUED)**

**VALVES:**

SHUTOFF VALVES: BALL VALVES, MSS SP-110, FULL PORT, TWO PART BRONZE, THREADED ENDS.

CHECK VALVES: MSS SP-80, BRONZE, SOLDER ENDS.

VACUUM RELIEF VALVES: ANSI Z21.22/CSA 4.4, BRASS.

WATER HEATER DRAIN VALVES: ASME BPVC SEC IV, BRONZE.

TEMPERATURE & PRESSURE RELIEF VALVE: ANSI Z21.22/CSA 4.4, BRASS, HOSE THREAD OUTLET.

THERMOSTATIC MIXING VALVE: BRONZE DUPLEX HIGH/LOW MIXING VALVE ASSEMBLY EQUIPPED WITH INLET AND OUTLET CHECKSTOPS, LOCKING ADJUSTMENT HANDLE, OUTLET BALL VALVE SHUTOFFS THERMOMETER ON OUTLET, CHECK VALVES, UNIONS AND SEDIMENT STRAINERS ON INLETS, 100 TO 150 DEGREE F MINIMUM ADJUSTMENT RANGE, +/- 2 DEGREES F ACCURACY.

AUTOMATIC GAS SHUTOFF VALVE WILL BE FURNISHED BY THE KITCHEN CONSULTANT. GAS INSTALLATION WILL BE BY THE PLUMBING CONTRACTOR.

**PIPE INSULATION:**

DOMESTIC COLD WATER: CLOSED-CELL FLEXIBLE ELASTOMERIC INSULATION, ASTM C534 TYPE 1, SELF-ADHESIVE BUTT JOINT AND SELF-ADHESIVE LAP, THERMAL CONDUCTIVITY: 0.245, WATER VAPOR TRANSMISSION, 0.03 PERMS, UV RESISTANT, ASTM G7 AND G90, FLAME SPREAD RATING OF 50 OR LESS PER ASME E84. 1/2 INCH THICKNESS.

DOMESTIC HOT WATER: PERFORMED FIBERGLASS INSULATION, BONDED WITH THERMOSETTING RESIN. COMPLY WITH ASTM C 547, TYPE I, GRADE A, WITH FACTORY-APPLIED ALL-SERVICE JACKET AND SELF-SEALING LAP. 1 INCH INSULATION THICKNESS.

**PIPE HANGERS AND SUPPORTS:**

COPPER CLAD CARBON STEEL PIPE HANGERS AND SUPPORTS, MSS SP-58. TYPE A BANDS OR CLEVIS HANGERS, GALVANIZED, CONTINUOUS THREAD 5/16-INCH DIAMETER ROD, NUTS AND WASHER, GALVANIZED PIPE SADDLES, 12 INCHES LONG. PROVIDE 25 PSI POLYISOCYANURATE THERMAL HANGER SHIELD INSERTS TO SUPPORT INSULATED PIPE WITHOUT COMPRESSION. HANGER SPACING IN ACCORDANCE WITH 2009 IPC.

**PIPING IDENTIFICATION:** PRE-PRINTED, PRETENSIONED SEMI-RIGID PLASTIC PIPE LABELS, COLOR-CODED, WITH LETTERING INDICATING SERVICE, AND SHOWING FLOW DIRECTION. 1-1/2 INCH MINIMUM LETTERING SIZE. FOR DOMESTIC COLD WATER PIPING PROVIDE WHITE LETTERING ON GREEN BACKGROUND. FOR DOMESTIC HOT WATER PIPING PROVIDE WHITE LETTERING ON YELLOW BACKGROUND. FOR NATURAL GAS PIPING PROVIDE BLACK LETTERING ON YELLOW BACKGROUND.

**GAS-FIRED TANK-TYPE WATER HEATER:**

ANSI Z21.10.3/CSA 4.3, CEMENT- OR GLASS-LINED STEEL TANK, 1" MINERAL FIBER INSULATION BETWEEN TANK AND JACKET, GAS CONTROL VALVE, 90-160 DEGREE F ADJUSTMENT RANGE. PROVIDE TEMPERATURE AND PRESSURE RELIEF VALVE, DRAIN VALVE, VACUUM RELIEF VALVE AND 4" DIAMETER GAS VENT AND SIDEWALL VENT CAP.

**PLUMBING FIXTURES:** WATER CONSERVATION TYPE IN CONFORMANCE WITH 2009 IPC. FIXTURES FOR USE BY PHYSICALLY HANDICAPPED INDIVIDUALS SHALL BE IN ACCORDANCE WITH ICC/ANSI A117.1. PLUMBING FIXTURES SHALL BE WHITE VITREOUS CHINA UNLESS OTHERWISE INDICATED. PROVIDE NECESSARY HARDWARE FOR PLUMBING FIXTURES, INCLUDING BUT NOT LIMITED TO WALL BRACKET SUPPORTS FOR LAVATORIES AND URINALS, (STAINLESS STEEL BOLTS, NUTS AND FITTINGS), GASKETS, DECORATIVE CAPS AND COVERS. PROVIDE ASSE 1037 BATTERY-POWERED SENSOR OPERATED FLUSH VALVES FOR WATER CLOSETS AND URINALS. FLOOR DRAINS SHALL HAVE NICKEL BRONZE FINISH. PLUMBING FIXTURES INDICATED AS BASIS OF DESIGN ON PLUMBING FIXTURE ROUGH-IN SCHEDULE SATISFY MATERIAL REQUIREMENTS.

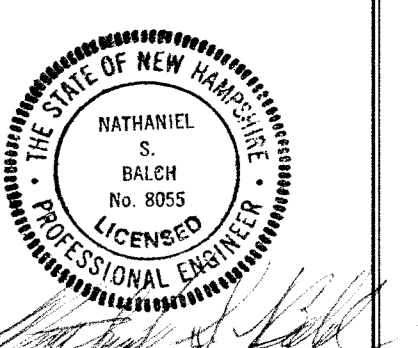

Seacoast Consulting Engineers, LLC  
**SCE**  
 261 Jennie Lane  
 Ellettsville, Maine 03903  
 207-370-7230  
 www.SeacoastEngineers.com  
 Project No. 2012-107  
 Scale As Noted  
 Date 03-09-2012  
 Designed By: NSB  
 Drawn By: MGV  
 Checked By: EAF

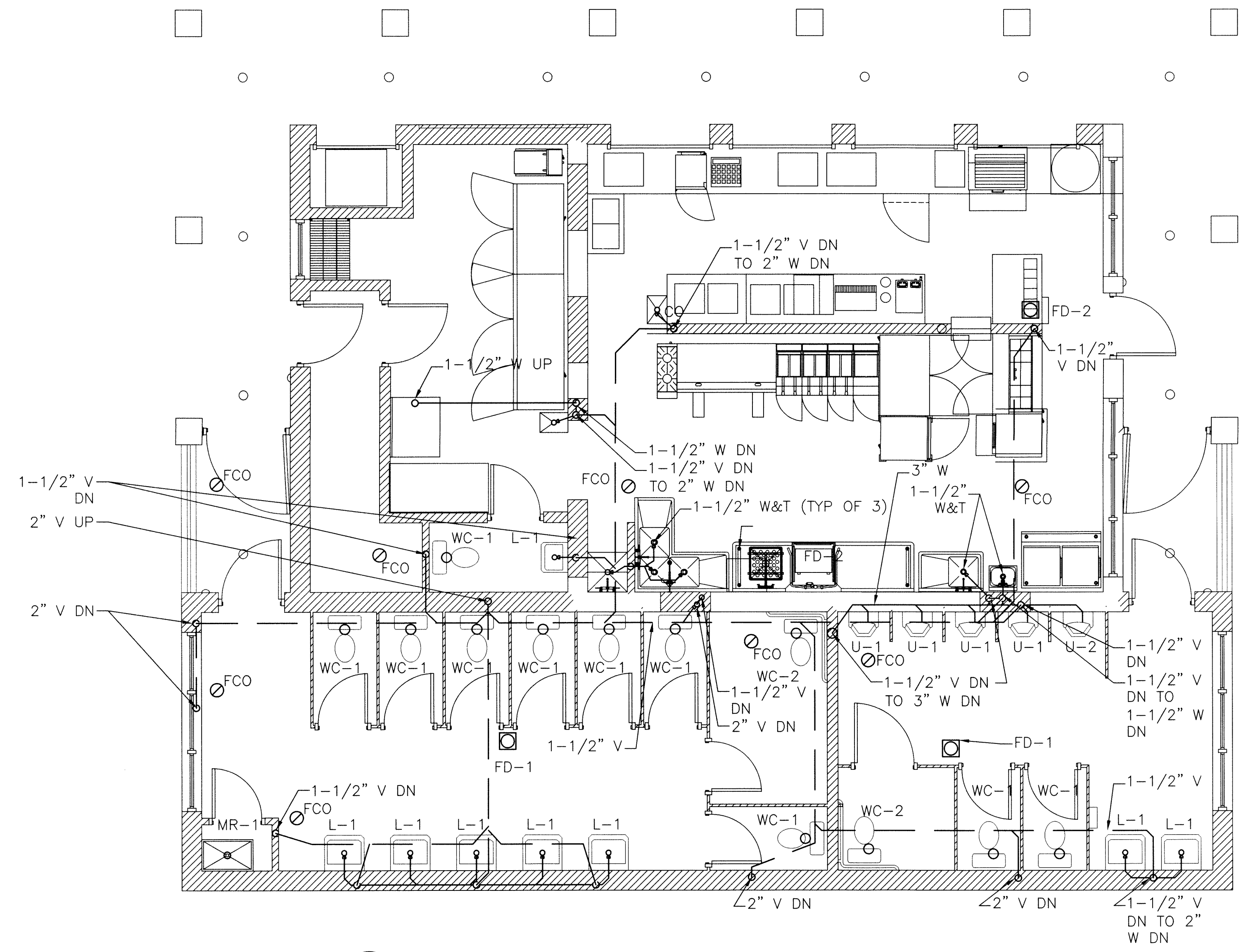
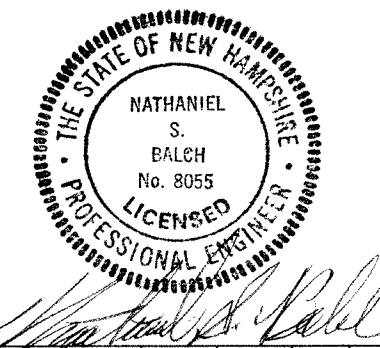

3 SANITARY PIPING PLAN  
P1.1 SCALE: 1/4" = 1'-0"

DRAWING NOTES  
1. REFER TO KITCHEN EQUIPMENT SCHEDULE FOR DESCRIPTIONS OF NUMBERED ITEMS.

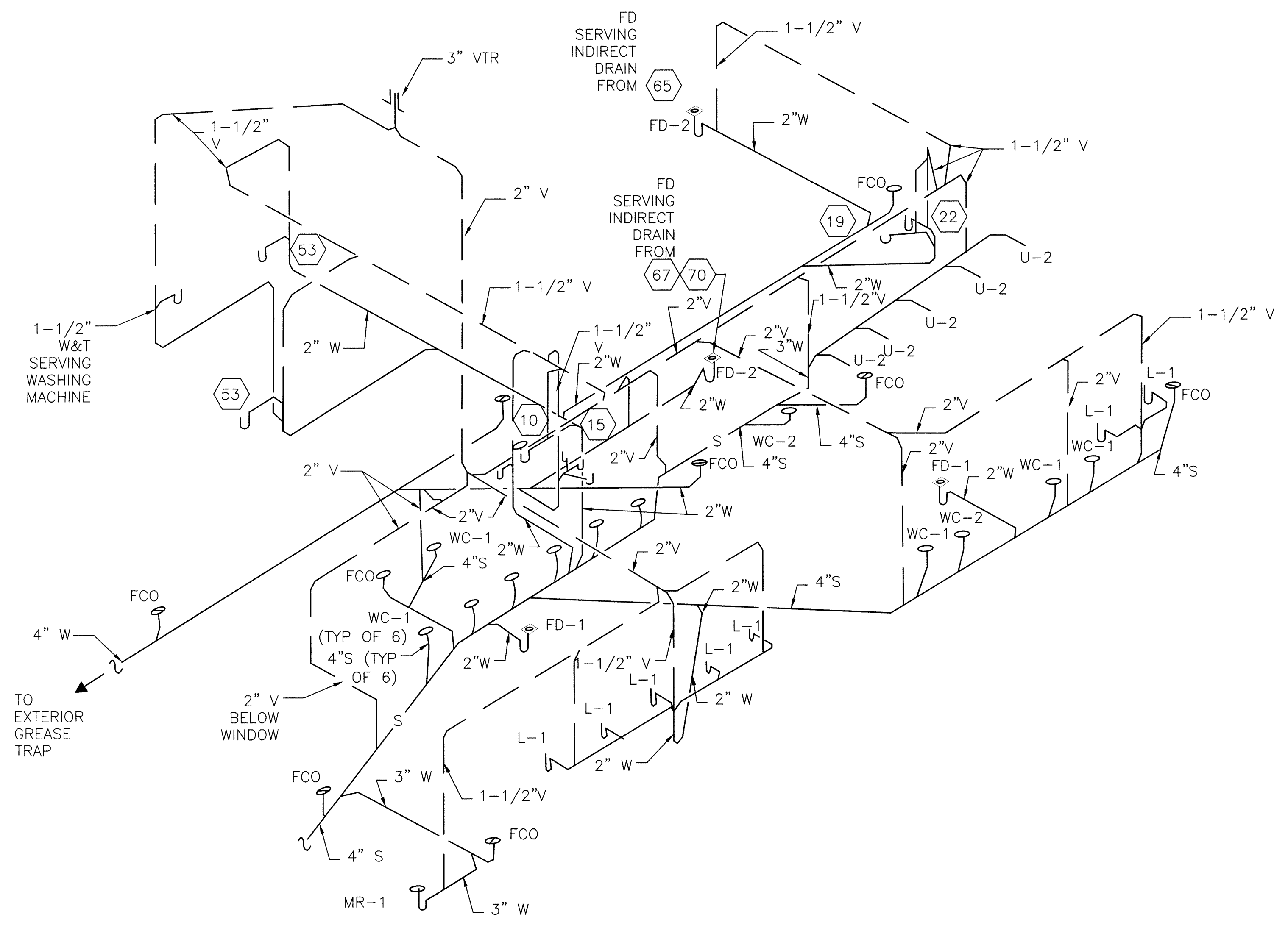

2 ISOMETRIC SANITARY PIPING RISER DIAGRAM  
P1.3 SCALE: NTS

\* The layouts for Women's Room #104 and Men's Room #106 have been updated and Unisex Bathroom #108 has been added since the Mechanical, Electrical, and Plumbing Drawings were originally issued. Refer to Architectural Sheet A1 for updated layout and fixture counts. Please account for Unisex Bathroom #108 receiving the same treatment as Women's Room #104 and Men's Room #106 for such items as power supply, lighting, fire alarm, ventilation, water supply, drainage, etc.

Seacoast Consulting  
Engineers, LLC

261 Jennie Lane  
Eliot, Maine 03903  
207-370-7230  
www.SeacoastEngineers.com

Designed By: USB  
Drawn By: JMW  
Checked By: EBF  
Project No. 2012-107  
SCALE: As Noted

Pavilion Building  
Prescott Park  
Portsmouth, NH  
PLUMBING PLAN AND RISER  
DIAGRAM