

CONTRACT DOCUMENTS

for

Harborwalk Park Pier

City of Portsmouth

Bid #55-15

City of Portsmouth, Rockingham County

Federal Project # X-A000(104)

State Project #13903

John P. Bohenko, City Manager

City of Portsmouth, New Hampshire

Prepared by:

City of Portsmouth
Engineering Division
Public Works Department

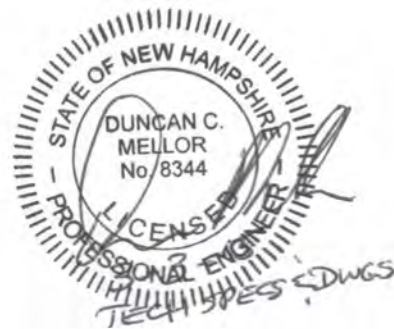

TABLE OF CONTENTS

ADVERTISEMENT FOR BIDS	3
INSTRUCTION TO BIDDERS	4
AWARD AND EXECUTION OF CONTRACT	8
PROPOSAL	10
BID BOND	14
BIDDER'S QUALIFICATIONS	16
AUTHORIZATION AND RELEASE	18
CONTRACT AGREEMENT	20
NOTICE OF INTENT TO AWARD	22
NOTICE TO PROCEED	23
CHANGE ORDER	24
PERFORMANCE BOND	25
LABOR AND MATERIALS PAYMENT BOND	27
MAINTENANCE BOND	29
CONTRACTOR'S AFFIDAVIT	30
CONTRACTOR'S RELEASE	31
INSURANCE REQUIREMENTS	33
GENERAL REQUIREMENTS	
SUMMARY	35
CONTROL OF WORK	38
TEMPORARY FACILITIES	42
MEASUREMENT AND PAYMENT	43
SPECIAL REQUIREMENTS	47
TECHNICAL SPECIFICATIONS	49
ATTACHMENT 1 – Davis Bacon Wage Requirements	86
ATTACHMENT 2 – Additional Requirements for LPA Projects	90
APPENDIX – Copies of Permits received for the project.	

Harborwalk Park Pier

Bid #55-15

INVITATION TO BID

Sealed bid proposals, **plainly marked**, (Harborwalk Park Pier, Bid Proposal #55-15) **on the outside of the mailing envelope as well as the sealed bid envelope**, addressed to the Finance/Purchasing Department, City Hall, 1 Junkins Avenue, Portsmouth, New Hampshire, 03801, will be accepted until 2 PM on April 15, 2015; at which time all bids will be publicly opened and read aloud.

The project consists of constructing a public viewing pier onto the newly built Harborwalk Park in downtown Portsmouth which is directly adjacent to the Memorial Bridge. The Contractor will be required to keep the park open to the public to the maximum degree possible during construction.

Plans and bid specifications are available at the City's website <http://www.cityofportsmouth.com/finance/purchasing.htm>. Addenda to this bid, if any, including written answers to questions, will be posted on the City of Portsmouth website. Addenda and updates will NOT be sent directly to vendors.

Completion date will be 120 calendar days from the date of the Notice to Proceed. Liquidated damages shall be assessed at \$100.00 per day.

Bidders must determine the quantities of work required and the conditions under which the work will be performed.

The City of Portsmouth further reserves the right to reject any or all bids, to waive technical or legal deficiencies, to re-bid, and to accept any bid that it may deem to be in the best interest of the City. Also, the City reserves the right to approve or deny subcontractors for this project.

Each Bidder shall furnish a bid security in the amount of ten percent (10%) of the bid. The Bid Security may be in the form of a certified check drawn upon a bank within the State of New Hampshire or a bid bond executed by a surety company authorized to do business in the State of New Hampshire, made payable to the City of Portsmouth, N.H.

This project is funded with Federal Transportation Enhancement (TE) funds administered by the State of New Hampshire Department of Transportation. Wage rates for all project labor will conform to federal Davis-Bacon wage rates (see Attachment 1). All work must be completed in accordance with the Federal Labor Standards Provisions, Equal Opportunity Act, and the Copeland Anti-Kickback Act.

If you have any questions please contact the Finance/Purchasing Department at the following number: 603-431-2006 X227.

INSTRUCTIONS TO BIDDERS

BIDDING REQUIREMENTS AND CONDITIONS

1. Special Notice to Bidders

Appended to these instructions is a complete set of bidding and general contract forms. These forms may be detached and executed for the submittal of bids. The plans, specifications, and other documents designated in the proposal form will be considered as part of the proposal, whether attached or not.

Addenda to this bid document, if any, including written answers to questions, will be posted by April 13, 2015 on the City of Portsmouth website at <http://www.cityofportsmouth.com/finance/purchasing.htm> under the project heading. Addenda and updates will NOT be sent directly to firms. Contractors submitting a bid should check the web site daily for addenda and updates after the release date. Firms should print out, sign and return addenda with the proposal. Failure to do so may result in disqualification.

2. Interpretation of Quantities in Bid Schedules

The quantities appearing in the bid schedule are approximate only and are prepared for the comparison of bids. Payment to the contractor will be made only for actual work performed and accepted in accordance with the contract. Any scheduled item of work to be done and materials to be furnished may be increased, decreased or omitted as hereinafter provided, and no claim for loss, anticipated profits or costs incurred in anticipation of work not ultimately performed will be allowed due to such increase or decrease.

3. Examination of Plans, Specifications and Site Work

The bidder is expected to examine carefully the site of the proposed work, the plans, standard specifications, supplemental specifications, special provisions and contract forms before submitting a proposal. The submission of a bid shall be considered conclusive evidence that the bidder has made such examination and is satisfied as to the conditions to be encountered in performing the work and as to the requirements of the contract. It will be conclusive evidence that the bidder has also investigated and is satisfied with the sources of supply for all materials.

Plans, surveys, measurements, dimensions, calculations, estimates and statements as to the condition under which the work is to be performed are believed to be correct, but the contractors must examine for themselves, as no allowance will be made for any errors or inaccuracies that maybe found therein.

4. Familiarity with Laws

The bidder is assumed to have made himself or herself familiar with all federal and state laws and all local by-laws, ordinances and regulations which in any manner affect those engaged or employed on the work or affect the materials or equipment used in the work or affect the conduct of the work, and the bidder, if awarded the contract, shall be obligated to perform the work in conformity with said laws, by-laws, ordinances and regulations notwithstanding its ignorance thereof. If the bidder shall discover any provision in the plans or specifications which is in conflict with any such law, by-law, ordinance or regulation the bidder shall forthwith report it to the engineer in writing.

5. Preparation of Proposal

a) The bidder shall submit its proposal upon the forms furnished by the Owner. The bidder shall specify a lump sum price in figures, for each pay item for which a quantity is given and shall also show the products of the respective prices and quantities written in figures in the column provided for that purpose and the total amount of the proposal obtained by adding the amount of the several items. All words and figures shall be in ink or typed.

If a unit price or a lump sum bid already entered by the bidder on the proposal form is to be altered it should be crossed out with ink, the new unit price or lump sum bid entered above or below it and initialed by the bidder, also with ink.

b) The bidder's proposal must be signed with ink by the individual, by one or more general partners of a partnership, by one or more members or officers of each firm representing a joint venture; by one or more officers of a corporation, by one or more members (if member-managed) or managers (if manager-managed) of a limited liability company, or by an agent of the contractor legally qualified and acceptable to the owner. If the proposal is made by an individual, his or her name and post office address must be shown, by a partnership the name and post office address of each general and limited partner must be shown; as a joint venture, the name and post office address of each venturer must be shown; by a corporation, the name of the corporation and its business address must be shown, together with the name of the state in which it is incorporated, and the names, titles and business addresses of the president, secretary and treasurer.

6. Nonconforming Proposals

Proposals will be considered nonconforming and may be rejected in the Owner's sole discretion for any of the following reasons:

- If the proposal is on a form other than that furnished by the Owner, or if the form is altered or any portion thereof is detached;
- If there are unauthorized additions, conditional or altered bids, or irregularities of any kind which may tend to make the proposal or any portion thereof incomplete, indefinite or ambiguous as to its meaning;
- If the bidder adds any provisions reserving the right to accept or reject an award, or to enter into a contract pursuant to an award; or
- If the proposal does not contain a unit price for each pay item listed except in the case of authorized alter pay items.

7. Proposal Guaranty

No proposal will be considered unless accompanied by a bid bond, surety, or similar guaranty of the types and in an amount not less than the amount indicated in the Invitation to Bid. All sureties shall be made payable to the "City of Portsmouth". If a bid bond is used by the bidder it shall be:

- In a form satisfactory to the Owner;
- With a surety company licensed, authorized to do business in, and subject to the jurisdiction of the courts of the State of New Hampshire; and
- Conditioned upon the faithful performance by the principal of the agreements contained in the sub-bid or the general bid.

In the event any irregularities are contained in the proposal guaranty, the bidder will have four business days (not counting the day of opening) to correct any irregularities. The corrected guaranty must be received by 4:00 p.m. If irregularities are not corrected to the satisfaction of the Owner, the Owner, in its sole discretion, may reject the bid.

8. Delivery of Proposals

When sent by mail, the sealed proposal shall be addressed to the Owner at the address and in the care of the official in whose office the bids are to be received. All proposals shall be filed prior to the time and at the place specified in the invitation for bids. Proposals received after the time for opening of the bids will be returned to the bidder, unopened.

9. Withdrawal of Proposals

A bidder will be permitted to withdraw his or her proposal unopened after it has been submitted if the Owner receives a request for withdrawal in writing prior to the time specified for opening the proposals.

10. Public Opening of Proposals

Proposals will be opened and read publicly at the time and place indicated in the invitation for bids. Bidders, their authorized agents, and other interested parties are invited to be present.

11. Disqualification of Bidders

Any or all of the following reasons may be deemed by Owner in its sole discretion as being sufficient for the disqualification of a bidder and the rejection of his proposal:

- More than one proposal for the same work from an individual, firm, or corporation under the same or different name;
- Evidence of collusion among bidders;
- Failure to submit all required information requested in the bid specifications;
- Lack of competency or of adequate machinery, plant or other equipment, as revealed by the statement of bidders qualification or otherwise;
- Uncompleted work which, in the judgment of the owner, might hinder or prevent the prompt completion of additional work if awarded;
- Failure to pay, or satisfactorily settle, all bills due for labor and materials on former contracts;

- Default or unsatisfactory performance on previous contracts; or
- Such disqualification would be in the best interests of the Owner.

12. Material Guaranty and Samples

Before any contract is awarded, the bidder may be required to furnish a complete statement of the origin, composition and manufacture of any or all materials to be used in the construction of the work, and the Owner may, in its sole discretion, reject the bid based on the contents of the statement or as a result of the failure of the bidder to submit the statement.

AWARD AND EXECUTION OF CONTRACT

1. Consideration of Proposals

a) After the proposals are opened and read, they will be compared on the basis of the total price to be charged to perform the work. The results of such comparisons will be immediately available to the public. In case of a discrepancy between the prices written in words and those written figures, the prices written in words shall govern. In case of a discrepancy between the total shown in the proposal and that obtained by adding the products of the quantities of items and unit bid prices, the latter shall govern.

b) The right is reserved to reject any or all proposals, to waive technicalities or to advertise for new proposals, if in the sole discretion of the Owner the best interest of the City of Portsmouth will be promoted thereby.

2. Award of Contract

The award will be based on the Base bid, or the Base Bid with any combination of Add Alternates the City deems to be in its best interest.

Within 30 calendar days after the opening of proposals, if a contract is to be awarded, the award will be made to the lowest responsible and qualified bidder whose proposal complies with all the requirements prescribed. A responsible and qualified bidder is one who is not disqualified and otherwise has a history and reputation for performing timely, quality work within project budgets. The successful bidder will be notified, in writing, mailed to the address on his or her proposal, that his or her bid has been accepted and that the bidder has been awarded the contract.

3. Cancellation of Award

The Owner reserves the right to cancel the award of any contract at any time before the execution of such contract by all parties without any liability of the Owner.

4. Return of Proposal Guaranty

All proposal guaranties, except those of the three lowest bidders, will be returned if requested immediately following the opening and checking of the proposals. The proposal guaranties of the three lowest bidders will be returned within ten days following the award of the contract if requested.

5. Contract Bonds

At the time of the execution of the contract, the successful bidder shall furnish:

- a) A performance bond in the amount of 100 percent of the contract amount.
- b) Labor and materials payment bond in the sum equal to 100 percent of the contract amount.

At the time of project completion, the successful bidder shall furnish:

- c) A maintenance bond in the amount equal to 10 percent of the contract amount. Such bond shall guarantee the repair of all damage due to faulty materials or workmanship provided or done by the contractor. The guarantee shall remain in effect for a period of one year after the date of final acceptance of the job by the Owner.

AWARD AND EXECUTION OF CONTRACT (continued)

Each bond shall be:

1. In a form satisfactory to the Owner.
2. With a surety company licensed and authorized to do business and with a resident agent designated for services of process in the State of New Hampshire.
3. Conditioned upon the faithful performance by the principal of the agreements contained in the original bid.

All premiums for the contract bonds are to be paid by the contractor.

6. Execution and Approval of Contract

The successful bidder will be required to present all contract bonds and execute the contract within 10 days following notification of acceptance of his or her bid. No contract shall be considered as in effect until it has been fully executed by all parties thereto.

7. Failure to Execute Contract

Failure to execute the contract and file acceptable bonds within 10 days after notification of acceptance of bid shall be just cause for the cancellation of the award and the forfeiture of the proposal guarantee which shall become the property of the Owner, not as a penalty, but in liquidation of damages sustained. Award may then be made to the next lowest responsible bidder, or the work may be re-advertised as the Owner may determine in its sole discretion.

Harborwalk Park Pier
Bid #55-15

PROPOSAL FORM

CITY OF PORTSMOUTH, N.H.

To the City of Portsmouth, New Hampshire, herein called the Owner.

The undersigned, as Bidder, herein referred to as singular and masculine declares as follows:

1. All interested in the Bid as Principals are named herein.
2. This bid is not made jointly, or in conjunction, cooperation or collusion with any other person, firm, corporation, or other legal entity;
3. No officer, agent or employee of the Owner is directly or indirectly interested in this Bid.
4. The bidder has carefully examined the site of the proposed work and fully informed and satisfied himself as to the conditions there existing, the character and requirements of the proposed work, the difficulties attendant upon its execution and the accuracy of all estimated quantities stated in this Bid, and the bidder has carefully read and examined the Drawings, Agreement, Specifications and other Contract Documents therein referred to and knows and understands the terms and provisions thereof;
5. The bidder understands that the quantities of work calculated in the Bid or indicated on the Drawings or in the Specifications or other Contract Documents are approximate and are subject to increase or decrease or deletion as deemed necessary by the Portsmouth City Engineer. Any such changes will not result in or be justification for any penalty or increase in contract prices; and agrees that, if the Bid is accepted the bidder will contract with the Owner, as provided in the Contract Documents, this Bid Form being part of said Contract Documents, and that the bidder will supply or perform all labor, services, plant, machinery, apparatus, appliances, tools, supplies and all other activities required by the Contract Documents in the manner and within the time therein set forth, and that the bidder will take in full payment therefor the following item prices, to wit:

PROPOSAL FORM (continued)

ITEM #	EST. QTY.	UNITS	ITEM DESCRIPTION & UNIT PRICE IN WORDS	UNIT PRICE IN FIGURES	ITEM TOTAL IN FIGURES
1	39	Ea	Support piles (CCA timber SYP)	\$ _____	\$ _____
2	242	Lf	Timber pile caps (CCA timber SYP)	\$ _____	\$ _____
3	33	Lf	Glu-Lam curved pile cap	\$ _____	\$ _____
4	1	Ls	Pile cap hardware	\$ _____	\$ _____
5	1400	Sf	Membrane (Ice & Water Shield)	\$ _____	\$ _____
6	384	Lf	4X8 cross bracing (CCA timber SYP)	\$ _____	\$ _____
7	156	Lf	4X8 horizontal bracing (CCA timber SYP)	\$ _____	\$ _____
8	57	Ea	Bracing hardware (HDG)	\$ _____	\$ _____
9	270	Lf	Deck rangers (Built out of CCA timbers SYP)	\$ _____	\$ _____
10	1344	Lf	3X12 Stringers (CCA timber SYP)	\$ _____	\$ _____
11	1	Ls	Stringer and Ranger Hardware	\$ _____	\$ _____
12	2400	Sf	Ipe Decking (2X6) with hardware	\$ _____	\$ _____
13	1	Ls	Remove, modify and/or salvage existing fencing according to plans	\$ _____	\$ _____

14	189	Lf	Construct railing system with all associated hardware	\$ _____	\$ _____
<hr/>					
15	14	Ea	Fender Piles with hardware and copper caps	\$ _____	\$ _____
<hr/>					
16	1	Ls	Pier to seawall connections and splice plates	\$ _____	\$ _____
<hr/>					
17	1	Ls	Install City supplied granite pavers where Chain link fence resides		
<hr/>					
18	2	Ea	Install City provided 10' +/- high fiberglass light pole with associated luminaire including conduit over the water attached to the underside of the deck with any associated wiring and mounting hardware.	\$ _____	\$ _____
<hr/>					
692	1	Ls	Mobilization	\$ _____	\$ _____
<hr/>					
Total Base Bid:				\$ _____	_____

The award will be based on the Base bid, or the Base Bid with any combination of Add Alternates the City deems to be in its best interest.

ADD ALTERNATIVES

At the owner's option, and in accordance with the General Conditions, the following Alternates and Unit Prices shall be used for additions and/or deletions to the Scope of Work, and shall be inclusive of furnishing and installing of material, labor, trucking, overhead, profit, equipment, hoisting, engineering, scaffolding, power hookups, protection, shop drawings, taxes, permits, appliances, delivery and supervision and shall remain in effect until completion of the contract.

The Owner will inform the Contractor which Alternates, if any, will be to the Base Bid prior to contract execution and bonding.

ADD ALTERNATIVES:

Bid Alternate #1: Provide and install 5 straight benches as shown on the plan set and detailed in the technical specifications.

Alt 1	5	Ea	Straight Benches	\$ _____	\$ _____
<hr/>					

BID SECURITY BOND

(This format provided for convenience, actual Bid Bond is acceptable in lieu of, if compatible.)

KNOW ALL MEN BY THESE PRESENTS, that we the undersigned

_____, as Principal, and

_____, as Surety, are hereby

held and firmly bound unto _____

IN THE SUM OF _____

as liquidated damages for payment of which, well and truly to be made we hereby jointly and severally bind ourselves, our heirs, executors, administrators, successors and assigns.

The condition of this obligation is such that whereas the Principal has submitted to the

A CERTAIN Bid attached hereto and hereby made a part hereof to enter into a contract in writing, hereinafter referred to as the "AGREEMENT" and or "CONTRACT", for

NOW THEREFORE,

- (a) If said Bid shall be rejected or withdrawn as provided in the INFORMATION FOR BIDDERS attached hereto or, in the alternative,

- (b) If said Bid shall be accepted and the Principal shall duly execute and deliver the form of AGREEMENT attached hereto and shall furnish the specified bonds for the faithful performance of the AGREEMENT and/or CONTRACT and for the payment for labor and materials furnished for the performance of the AGREEMENT and or CONTRACT,

then this obligation shall be void , otherwise it shall remain in full force and effect; it being expressly understood and agreed that the liability of the Surety for any and all claims hereunder in no event shall exceed the amount of this obligation.

BID SECURITY BOND (continued)

The Surety, for value received, hereby agrees that the obligation of said surety and its bond shall be in no way impaired or affected by any extensions of the time within such BID may be accepted, and said Surety does hereby waive notice of any such extension.

IN WITNESS WHEREOF, the parties hereto have duly executed

this bond on the _____ day of _____, 20__.

(Name of Principal) L.S.

(SEAL)

BY _____

(Name of Surety)

BY _____

STATEMENT OF BIDDER'S QUALIFICATIONS

All questions must be answered and the data given must be clear and comprehensive. This statement must be notarized. Add separate sheets if necessary. **This statement shall be filled out and submitted with Bid.**

1. Name of Bidder
2. Permanent Main Office Address
3. Form of Entity
4. When Organized
5. Where Organized
6. How many years have you been engaged in the contracting business under your present name; also state names and dates of previous firm names, if any.
7. Contracts on hand; (schedule these, showing gross amount of each contract and the approximate anticipated dates of completion).
8. General character of work performed by your company.
9. Have you ever failed to complete any work awarded to you? ____ (no) ____ (yes). If so, where and why?
10. Have you ever defaulted on a contract?
____ (no) ____ (yes). If so, where and why?
11. Have you ever failed to complete a project in the time allotment according to the Contract Documents?
____ (no) ____ (yes). If so, where and why?
12. List your last 10 contracts of \$200,000 or more recently performed, stating:
 - A. the approximate cost for each
 - B. the nature of the work
 - C. the month and year completedIf the Bidder has performed fewer than 10 contracts of \$200,000 or more, provide all project history since the date of the organization or the last three years.
13. List your major equipment available for this contract.
14. List your key personnel such as project superintendent and foremen available for this contract.

STATEMENT OF BIDDERS QUALIFICATIONS (continued)

15. List any subcontractors whom you would expect to use for the following (unless this work is to be done by your own organization).

a. Pilings _____

b. Electrical Work _____

16. With what banks do you do business?

a. Do you grant the Owner permission to contact this/these institutions?
____(yes) ____ (no).

b. Latest Financial Statements, certified audited if available, prepared by an independent certified public accountant, must be attached and Certified Audited Statement are preferred. Internal statements may be attached only if independent statements were not prepared.

Dated at _____ this _____ day of _____, 20____.

Name of Bidder

BY _____

TITLE _____

State of _____

County of _____

_____ being duly sworn, deposes and

says that the bidder is _____ of _____
(Name of Organization)

and answers to the foregoing questions and all statements contained therein are true and correct.

Sworn to before me this _____ day of _____, 20____.

Notary of Public

My Commission expires _____

AUTHORIZATION AND RELEASE

As part of the Bid, the Bidder shall execute and submit the Authorization and Release set forth below:

By submitting this Bid, Bidder authorizes Owner, Engineer, and their employees and agents to make such inquiries as they deem necessary to determine whether Bidder's qualifications are satisfactory. Bidder hereby agrees to release and hold harmless Owner, Engineer and any person or entity requested to respond to Owner or Engineer regarding Bidder's qualifications from any and all claims and causes of action related to such inquiries, including without limitation actions for defamation, slander or interference with contractual relations.

Bidder: _____

By: _____

Name: _____

Title: _____

CONTRACT AGREEMENT

Harborwalk Park Pier

Bid #55-15

THIS AGREEMENT made as of the ____ day of ____ in the year **2015**, by and between the City of Portsmouth, New Hampshire (hereinafter call the Owner) and _____ (hereinafter called the Contractor),

WITNESSETH; that the Owner and Contractor, in consideration of the mutual covenants hereinafter set forth, agree as follows:

ARTICLE I- Work - The Contractor shall perform all work as specified or indicated in the Contract Documents for the completion of the Project.

- A) The Contractor shall provide, at his expense, all labor, materials, equipment and incidentals as may be necessary for the expeditious and proper execution of the Project.
- B) All work under this contract shall be performed in accord with Attachments 1 and 2 to this Agreement which set forth requirements by funding sources.

ARTICLE II - ENGINEER - The City Engineer, or his authorized representative will act as engineer in connection with completion of the Project in accordance with the Contract Documents.

ARTICLE III - CONTRACT TIME - The work will commence in accordance with the Notice to Proceed.

ARTICLE IV - CONTRACT PRICE - Owner shall pay Contractor for performance of the work in accordance with the Contract Documents as shown under item prices in the Bid Proposal.

ARTICLE V - PAYMENT - Partial payments will be made in accordance with the Contract Documents. Upon final acceptance of the work and settlement of all claims, Owner shall pay the Contractor the unpaid balance of the Contract Price, subject to additions and deductions provided for in the Contract Documents.

ARTICLE VI - LIQUIDATED DAMAGES - In event the Contractor fails to successfully execute the work within the specified contract time the Owner shall assess the Contractor liquidated damages in the amount of **one hundred dollars** for each calendar day beyond the specified completion date. Said liquidated damages shall be deducted from the Contract Price prior to final payment of the Contractor.

CONTRACT AGREEMENT (continued)

ARTICLE VII - CONTRACT DOCUMENTS - The Contract Documents which comprise the contract between Owner and Contractor are attached hereto and made a part hereof and consist of the following:

- 8.1 This Agreement
- 8.2 Contractor's Bid and Bonds
- 8.3 Notice of Award, Notice to Proceed
- 8.4 Instruction to Bidders
- 8.5 General Requirements, Control of Work, Temporary Facilities, Measurement and Payment, Special Requirements, Utilities and Drawings
- 8.6 Insurance Requirements
- 8.7 Technical Specifications
- 8.8 Drawings
- 8.9 Attachments 1 and 2 (Provisions of Grant Agreement)
- 8.10 Any modifications, including change orders, duly delivered after execution of this Agreement.

ARTICLE VIII - TERMINATION FOR DEFAULT - Should contractor at any time refuse, neglect, or otherwise fail to supply a sufficient number or amount of properly skilled workers, materials, or equipment, or fail in any respect to prosecute the work with promptness and diligence, or fail to perform any of its obligations set forth in the Contract, Owner may, at its election, terminate the employment of Contractor, giving notice to Contractor in writing of such election, and enter on the premises and take possession, for the purpose of completing the work included under this Agreement, of all the materials, tools and appliances belonging to Contractor, and to employ any other persons to finish the work and to provide the materials therefore at the expense of the Contractor.

ARTICLE IX - INDEMNIFICATION OF OWNER - Contractor will indemnify Owner against all suits, claims, judgments, awards, loss, cost or expense (including without limitation attorneys fees) arising in any way out of the Contractor's performance or non-performance of its obligations under this Contract. Contractor will defend all such actions with counsel satisfactory to Owner at its own expense, including attorney's fees, and will satisfy any judgment rendered against Owner in such action.

ARTICLE X - PERMITS - The Contractor will secure at its own expense, all permits and consents required by law as necessary to perform the work and will give all notices and pay all fees and otherwise comply with all applicable City, State, and Federal laws, ordinances, rules and regulations.

ARTICLE XI - INSURANCE - The Contractor shall secure and maintain, until acceptance of the work, insurance with limits not less than those specified in the contract.

ARTICLE XII - MISCELLANEOUS -

- 13.1 Neither Owner nor Contractor shall, without the prior written consent of the other, assign, sublet or delegate, in whole or in part, any of its rights or obligations under any of the Contract Documents; and, specifically not assign any monies due, or to become due, without the prior written consent of Owner.

CONTRACT AGREEMENT (continued)

- 13.2 Owner and Contractor each binds himself, his partners, successors, assigns and legal representatives, to the other party hereto in respect to all covenants, agreements and obligations contained in the Contract Documents.
- 13.3 The Contract Documents constitute the entire Agreement between Owner and Contractor and may only be altered amended or repealed by a duly executed written instrument.
- 13.4 This Contract shall be governed by the laws of the State of New Hampshire without regard to the principles of conflict of laws thereof.
- 13.5 The parties hereby agree that jurisdiction and venue for any action related to or arising from this contract shall reside with the Rockingham County Superior Court unless the parties shall agree otherwise.

ARTICLE XIII - OTHER PROVISIONS – Not Applicable

IN WITNESS WHEREOF, the parties hereunto executed this AGREEMENT the day and year first above written.

NAME OF BUSINESS:

BY: _____

TITLE: _____

ATTEST: _____

(SEAL)

CITY OF PORTSMOUTH, N.H.

BY: _____

John P. Bohenko

TITLE: City Manager

ATTEST: _____

(SEAL)

NOTICE OF INTENT TO AWARD

Date:

TO:

IN AS MUCH as you were the low responsible bidder for work entitled:

Harborwalk Park Pier

Bid #55-15

In the City of Portsmouth, New Hampshire, you are hereby notified that the City intends to award the aforesaid project to you.

You are further instructed to immediately take the necessary steps for execution of the Contract within ten (10) calendar days from the date of this Notice.

Prior to starting work you must deliver to the Owner certificates of insurance and bonds which you are required to purchase and maintain in accordance with the Contract Documents. In addition, you must deliver to the Owner the certification from the Landscape subcontractor that type, number and size of trees specified has been located, acquired and set aside so that they will be available for installation at the end of the construction phase. The City reserves the right to revoke this Notice if you fail to take the necessary steps to execute this Contract.

City of Portsmouth
Portsmouth, New Hampshire

Judie Belanger,
Finance Director

NOTICE TO PROCEED

DATE:

**Harborwalk Park Pier
Bid #55-15**

TO:

YOU ARE HEREBY NOTIFIED TO COMMENCE WORK IN ACCORDANCE
WITH THE AGREEMENT DATED _____, ON OR
BEFORE _____ AND THE DATE OF COMPLETION OF ALL WORK SHALL
BE _____.

CITY OF PORTSMOUTH, N.H.

BY _____

TITLE _____

ACCEPTANCE OF NOTICE

RECEIPT OF THE ABOVE NOTICE TO
PROCEED IS HEREBY ACKNOWLEDGED BY

This the _____ day of _____ 20__

By: _____

Title: _____

CHANGE ORDER

Change Order Number

Date of Issuance:

Owner: City of Portsmouth

Contractor:

You are directed to make the following changes in the Contract Documents:

Description:

Purpose of Change Order:

Attachments:

CHANGE IN CONTRACT PRICE

CHANGE IN CONTRACT TIME

Original Contract Price:
\$

Original Contract Time:
120 days

Contract Price prior to this
Change Order:
\$

Contract Time prior to this
Change Order:

Net Increase or Decrease of
this Change Order:
\$

Net Increase or Decrease of
this Change Order:

Contract Price with all
approved Change Orders:
\$

Contract Time with all
approved Change Orders:

RECOMMENDED:

RECOMMENDED:

APPROVED:

by _____

by _____

by _____

PW Director

City Finance

NHDOT Project Manager

APPROVED:

APPROVED:

by _____

by _____

City Manager

Contractor

PERFORMANCE BOND

(This format provided for convenience, actual Performance Bond is acceptable in lieu, if compatible)

Bond Number _____

KNOW ALL MEN BY THESE PRESENTS

that _____ as principal, hereinafter called Contractor, and _____ (Surety Company) a [corporation] organized and existing under the laws of the State of _____ and authorized to do business in the State of New Hampshire as surety, hereinafter called Surety, are held and firmly bound unto the City of Portsmouth, N.H., hereinafter called Owner, in the amount of _____ Dollars (\$ _____), for the payment whereof Contractor and Surety bind themselves, their heirs, executors, administrators, successors and assigns, jointly and severally, firmly by these presents. WHEREAS, Contractor has by written agreement dated _____ entered into a contract with Owner for **Harborwalk Park Pier** in accordance with drawings and specifications prepared Gorrill-Palmer Consulting Engineers Inc. on behalf of the City of Portsmouth Community Development Department, 1 Junkins Avenue, Portsmouth, N.H. 03801; which contract is by reference made a part hereof, and is hereinafter referred to as the Contract.

NOW, THEREFORE, THE CONDITION OF THIS OBLIGATION is such that if the Contractor shall well and faithfully do and perform the things agreed by him to be done and performed, according to the terms of said Contract and such alterations as may be made in said Contract during progress work, and shall further indemnify and save harmless the said Owner in accordance with the Contract, and shall remedy without cost to the Owner any defect which may develop within one year from the time of completion and acceptance of the work.

The Surety hereby waives notice of any alteration in work or extension of time made by the Owner or any of its agents or representatives.

Whenever Contractor shall be, and declared by Owner to be, in default under the Contract, the Owner having performed Owner's obligations thereunder, the Surety may promptly remedy the default, or shall promptly:

- (1) Complete the Contract in accordance with its terms and conditions, or
- (2) Obtain a bid or bids for submission to the Owner for completing the Contract in accordance with its terms and conditions, and upon determination by Owner and Surety of the lowest responsible Bidder, arrange for a contract between such Bidder and Owner and make available as work progresses (even though there should be a default or a succession of defaults under the contract of completion arranged under this paragraph) sufficient funds to pay the cost of completion less the balance of the contract price; but not exceeding, including other costs and damages for which the Surety may be liable hereunder, the amount set forth in the first paragraph hereof. The term "balance of the contract price", as used in this paragraph, shall mean the total amount payable by the Owner to Contractor under the Contract and any amendments thereto, less the amount paid by Owner to Contractor.

Any suit under this bond must be instituted before the expiration of (2) years from the date on which final payment under the contract falls due.

PERFORMANCE BOND (continued)

No right of action shall accrue on this bond to or for the use of any person or corporation other than the Owner named herein or the heirs, executors, administrators or successors of Owner.

Signed and sealed this _____ day of _____

A.D., 20__ .

In the presence of:

(Witness) (Principal) (Seal) BY: _____

(Surety Company)

(Witness) (Title) (Seal) BY: _____

Note:

If the Principal (Contractor) is a partnership, the Bond should be signed by each of the partners.

If the Principal (Contractor) is a corporation, the Bond should be signed in its correct corporate name by its duly authorized Officer or Officers.

If this bond is signed on behalf of the Surety by an attorney-in-fact, there should be attached to it a duly certified copy of his Power of Attorney showing his authority to sign such Bonds.

There should be executed an appropriate number of counterparts of the bond corresponding to the number of counterparts of the Agreement.

LABOR AND MATERIAL PAYMENT BOND

(This format provided for convenience, actual Labor and Material Bond is acceptable in lieu, if compatible)

Bond Number _____

KNOW ALL MEN BY THESE PRESENTS:

that _____
as Principal, hereinafter called Contractor, and _____
_____ (Surety Company) a corporation organized and existing under the laws of the State of _____ and authorized to do business in the State of New Hampshire hereinafter called Surety, are held and firmly bound unto the City of Portsmouth, N.H. e, hereinafter called Owner, for the use and benefit of claimants as herein below defined , in the amount of _____ Dollars (\$ _____), for the payment whereof Principal and Surety bind themselves, their heirs, executors, administrators, successors and assigns, jointly and severally, firmly by these presents.

WHEREAS, Principal has by written agreement dated _____ entered into a contract with Owner for entered into a contract with Owner for **Harborwalk Park Pier** in accordance with drawings and specifications prepared Gorrill-Palmer Consulting Engineers Inc. on behalf of the City of Portsmouth Community Development Department, 1 Junkins Avenue, Portsmouth, N.H. 03801; which contract is by reference made a part hereof, and is hereinafter referred to as the Contract. hereinafter referred to as the Contract.

NOW, THEREFORE, THE CONDITION OF THIS OBLIGATION is such that the Principal shall promptly make payment to all claimants as hereinafter defined, for all labor and material used or reasonably required for use in the performance of the Contract and for the hire of all equipment, tools, and all other things contracted for or used in connection therewith, then this obligation shall be void, otherwise it shall remain in full force and effect, subject however, to the following conditions:

- (1) A claimant is defined as one having a direct contract with the Principal or, with a subcontractor of the Principal for labor, material, equipment, or other things used or reasonably required for use in the performance of the Contract. "Labor and material" shall include, but not be limited to, that part of water, gas, power, light, heat, oil and gasoline, telephone service or rental of equipment applicable to the Contract.
- (2) The above named Principal and Surety hereby jointly and severally agree with the Owner that every claimant as herein defined, who has not been paid in full before the expiration of a period of ninety (90) days after the date on which the last of such claimant's work or labor was done or performed, or materials were furnished by such a claimant, may sue on this bond for the use of such claimant, prosecute the suit by final judgment for such sum or sums as may be justly due claimant, and have execution thereon. The Owner shall not be liable for the payment of any such suit or any costs or expenses of any such suit, and Principal and Surety shall jointly and severally indemnify, defend and hold the Owner harmless for any such suit, costs or expenses.
- (3) No suit or action shall be commenced hereunder by any claimant:

LABOR AND PAYMENT BOND (continued)

(a) Unless Claimant, other than one having a direct contract with the Principal, shall have given notice to all the following:

The Principal, the Owner and the Surety above named, within six (6) calendar months after such claimant did or performed the last of the work or labor, or furnished the last of the materials for which said claim is made, stating with substantial accuracy the amount claimed and the name of the party to whom the materials were furnished, or for whom the work or labor was done or performed. Such notice shall be served by mailing the same by registered mail or certified mail, postage prepaid, in an envelope addressed to the Principal, Owner, and Surety, at any place where an office is regularly maintained for the transaction of business, or served in any manner in which legal process may be served in the State of New Hampshire save that such service need not be made by a public officer.

(b) After the expiration of one (1) year following the date on which Principal ceased all work on said Contract, it being understood, however, that if any limitation embodied in this bond is prohibited by any law controlling the construction hereof, such limitation shall be deemed to be amended so as to be equal to the minimum period of limitation permitted by such law.

(c) Other than in a State court of competent jurisdiction in and for the county or other political subdivision of the State in which the project, or any part thereof, is situated, or in the United States District Court for the district in which the project, or any part thereof, is situated, and not elsewhere. (4) The amount of this bond may be reduced by and to the extent of any payment of payments made in good faith hereunder, inclusive of the payment by Surety of mechanics' liens which may be filed on record against said improvement, whether or not claim for the amount of such lien by presented under and against this bond.

Signed and sealed this _____ day of _____, 20__ . . . In the presence of:

(Witness) (Principal) BY: _____ (Seal)

(Surety Company)

(Witness) (Title) BY: _____ (Seal)

Note:

If the Principal (Contractor) is a partnership, the Bond should be signed by each of the partners.

If the Principal (Contractor) is a corporation, the Bond should be signed in its correct corporate name by its duly authorized Officer or Officers.

If this bond is signed on behalf of the Surety by an attorney-in-fact, there should be attached to it a duly certified copy of his Power of Attorney showing his authority to sign such Bonds.

There should be executed an appropriate number of counterparts of the bond corresponding to the number of counterparts of the Agreement.

MAINTENANCE BOND

A maintenance bond in the amount of **10%** of the contract price with a corporate surety approved by the Owner will be required. Such bond shall be provided at the time of Contract completion and shall guarantee the repair of all damage due to faulty materials or workmanship provided or done by the Contractor. This guarantee shall remain in effect for a period of one year after the date of final acceptance of the job by the Owner.

CONTRACTOR'S AFFIDAVIT

STATE OF _____:

COUNTY OF _____:

Before me, the undersigned, a _____
(Notary Public, Justice of the Peace)

in and for said County and State personally appeared, _____
(Individual, Partner, or duly authorized representative of Corporate)

who being duly sworn according to law deposes and says
that the cost of labor, material, and equipment and
outstanding claims and indebtedness of whatever nature
arising out of the performance of the Contract between

CITY OF PORTSMOUTH, NEW HAMPSHIRE

and _____
(Contractor)

of _____

Dated: _____

Has been paid in full for Construction of:

Harborwalk Park Pier Bid #55-15
--

(Individual, Partner, or
duly authorized
representative of
Corporate Contractor)

Sworn to and subscribed
before me this _____ day
of _____ 20____

CONTRACTOR'S RELEASE

KNOW ALL MEN BY THESE PRESENTS that

(Contractor) of _____, County of _____ and State
of _____ do hereby acknowledge
that _____ (Contractor)

has on this day had, and received from the
CITY OF PORTSMOUTH NEW HAMPSHIRE, final and completed payment for the Construction
of:

Harborwalk Park Pier Bid #55-15
--

NOW THEREFORE, the said _____

(Contractor)

for myself, my heirs, executors, and administrators) (for itself, its successors and assigns) do/does by these presents remise, release, quit-claim and forever discharge the City of Portsmouth, New Hampshire, its successors and assigns, of and from all claims and demands arising from or in connection with the said Contract dated _____, and of and from all, and all manners of action and actions, cause and causes of action and actions, suits, debts, dues, duties, sum and sums of money, accounts, reckonings, bonds, bills, specifications, covenants, contracts, agreements, promises, variances, damages, judgments, extents, executions, claims and demand, whatsoever in law of equity, or otherwise, against the City of Portsmouth, New Hampshire, its successors and assigns, which (I, my heirs, executors, or administrators) (it, its successors and assigns) ever had, now have or which (I, my heirs, executors, or administrators) (it, its successors and assigns) hereafter can shall or may have, for, upon or by reason of any matter, cause, or thing whatsoever; from the beginning of record time to the date of these presents.

CONTRACTOR'S RELEASE (continued)

IN WITNESS WHEREOF, _____

(Contractor)

has caused these presents to be duly executed this _____
_____ day of _____, 20__.

Signed, Sealed and Delivered
in the presence of:

(Individual-Contractor) (Seal)

(Partnership-Contractor) (Seal)

(Partner) BY _____ (Seal)

Attested: _____
(Corporation)

(Secretary) BY _____
(President or Vice President)

(Corp. Seal)

INSURANCE REQUIREMENTS

Insurance shall be in such form as will protect the Contractor from all claims and liabilities for damages for bodily injury, including accidental death, and for property damage, which may arise from operations under this contract whether such operation by himself or by anyone directly or indirectly employed by him.

AMOUNT OF INSURANCE

- A) Comprehensive General Liability:
Bodily injury or Property Damage - \$2,000,000
Per occurrence and general aggregate
- B) Automobile and Truck Liability:
Bodily Injury or Property Damage \$2,000,000
Per occurrence and general aggregate

(As to items A and B above, 1 million per occurrence is acceptable if combined with sufficient excess policy.)

Additionally, the Contractor shall purchase and maintain the following types of insurance:

- A) Full Workers Comprehensive Insurance coverage for all people employed by the Contractor to perform work on this project. This insurance shall at a minimum meet the requirements of the most current laws of the State of New Hampshire.
- B) Contractual Liability Insurance coverage in the amounts specified above under Comprehensive General Liability.
- C) Product and Completed Operations coverage to be included in the amounts specified above under Comprehensive General Liability.
- D) Note: The City of Portsmouth has Builders Risk coverage for its own losses.

ADDITIONAL INSURED

All liability policies (including any excess policies used to meet coverage requirements) shall include the City of Portsmouth, New Hampshire as named Additional Insured.

- A) The contractor's insurance shall be primary in the event of a loss.
- B) The Additional Insured endorsement must include language specifically stating that the entity is to be covered for all activities performed by, or on behalf of, the contractor, including the City of Portsmouth's general supervision of the contractor.

INSURANCE REQUIREMENTS (continued)

- C) City of Portsmouth shall be listed as a Certificate Holder. The City shall be identified as follows:

City of Portsmouth
Attn: Legal Department
1 Junkins Avenue
Portsmouth, NH 03801

GENERAL REQUIREMENTS

PART 1 - SUMMARY

1.1 SCOPE OF WORK

- A. The proposed work for this project includes the construction of a wooden pier structure as detailed on the plans and specifications. There are provisions for lighting and amenities as part of the structure.

1.2 LIMITS OF WORK

- A. The limit of work for this structure is limited to the structure itself and modifications to the existing fencing and railings as described in the documents. The conduit for the electrical devices has been stubbed out through the seawall for use on the pier.

1.3 SURVEY/CONSTRUCTION

- A. Survey control is noted on the Plan if necessary.

1.4 INTENT OF CONTRACT

- A. The intent of the Contract is to provide for the construction and completion in every detail of the work described.

1. The Contractor shall furnish all labor, materials, equipment, tools, transportation and supplies required to complete the work in accordance with the terms of the Contract.
2. The Contractor shall be required to conform to the intent of the plans and specifications. No extra claims shall be allowed for portions of the work not specifically addressed in the plans and specifications but required to produce a whole and complete project, such work will be considered subsidiary to the bid items.

GENERAL REQUIREMENTS (continued)

1.5 INCIDENTAL WORK

- A. Incidental work items for which separate payment is not measured includes, but is not limited to, the following items:
 - 1. Public Safety
 - 2. Daily clean up
 - 3. Removing and resetting Existing signs if necessary.
 - 4. Restoration of property
 - 5. Cooperation with other contractors, abutters and utilities.
 - 6. Utility crossings, unless otherwise paid for.
 - 7. Steel and/or wood sheeting/bracing work platforms etc. as required.
 - 8. Accessories and fasteners or components required to make items paid for under unit prices or lump sum items complete and functional.

1.6 ALTERATION OF PLANS OR OF CHARACTER OF WORK

- A. The Owner reserves the right, without notice to Surety, to make such alterations of the plans or of the character of the work as may be necessary or desirable to complete fully and acceptably the proposed construction; provided that such alterations do not increase or decrease the contract cost. Within these cost limits, the alterations authorized in writing by the Owner shall not impair or affect any provisions of the Contract or bond and such increases or decreases of the quantities as a result from these alterations or deletions of certain items, shall not be the basis of claim for loss or for anticipated profits by the contractor. The contractor shall perform the work as altered at the contract unit price or prices.

1.7 EXTRA WORK ITEMS

- A. Extra work shall be performed by the Contractor in accordance with the specifications and as directed, and will be paid for at a price as provided in the Contract documents or if such pay items are not applicable than at a price negotiated between the contractor and the Owner or at the unit bid price.
- B. If the Owner determines that extra work is to be performed, a change order will be issued.

1.8 CHANGE ORDERS

- A. The Owner reserves the right to issue a formal change order for any increase, decrease, deletion, or addition of work or any increase in contract time or price.

GENERAL REQUIREMENTS (continued)

- B. The contractor shall be required to sign the change order and it shall be considered as part of the Contract documents.

1.9 FINAL CLEAN UP

- A. Before acceptance of the work, the contractor shall remove from the site all machinery, equipment, surplus materials, rubbish, temporary structures, barricades and signs. All parts of the work shall be left in a neat and presentable condition. On all areas used or occupied by the contractor, regardless of the contract limits, the bidder shall clean-up all sites and storage grounds.
- B. The items prescribed herein will not be paid for separately, but shall be paid for as part of the total contract price.

1.10 ERRORS AND INCONSISTENCY IN CONTRACT DOCUMENTS

- A. Any provisions in any of the Contract Documents that may be in conflict with the paragraphs in these General Requirements shall be subject to the following order of precedence for interpretation.
 - 1. Technical Specifications will govern General Requirements

GENERAL REQUIREMENTS (continued)

PART 2 - CONTROL OF WORK

2.1 AUTHORITY OF ENGINEER

- A. All work shall be done under supervision of the City Engineer and to his satisfaction. The City Engineer will decide all questions which may arise as to the quality and acceptability of materials furnished and work performed and as to the rate of progress of the work; all questions that may arise as to the interpretation of the plans and specifications; and all questions as to the acceptable fulfillment of the Contract by the Contractor.
- B. The City Engineer will have the authority to suspend the work wholly or in part for such periods as he may deem necessary due to the failure of the Contractor to correct conditions unsafe for workers or the general public; for failure to carry out provisions of the Contract; for failure to carry out orders; for conditions considered unsuitable for the prosecution of the work, including unfit weather; or for any other condition or reason deemed to be in the public interest. The Contractor shall not be entitled any additional payments arising out of any such suspensions.
- C. The Owner reserves the right to demand a certificate of compliance for a material or product used on the project. When the certificate of compliance is determined to be unacceptable to the City Engineer the Contractor may be required to provide engineering and testing services to guarantee that the material or product is suitable for use in the project, at its expense (see Sample of Certificate of Compliance).
- D. The Contractor shall plan paving operations so that the Engineer will have sufficient advanced notification to provide the necessary inspection and testing. Sufficient notification will be considered 48 hours.
 - 1. In the event that paving is suspended, the 48 hour notification shall be required again before restarting the paving operations unless otherwise agreed by the Engineer.
 - 2. Consistent notification of paving intent without actually paving will result in the following actions:
 - a. First offense – verbal warning
 - b. Second offense – written warning
 - c. Third and subsequent – liquidated damages will be charged for one working day.

2.2 REMOVAL OF UNACCEPTABLE AND UNAUTHORIZED WORK

- A. If the City determines that non-conforming work substantially conforms to the Contract, the City may accept the non-conforming work provided that the City

GENERAL REQUIREMENTS (continued)

may require a credit to the City to be deducted from amounts otherwise due the Contractor. If the City and Contractor cannot agree to the amount of the credit, the work shall be unacceptable work.

- B. The Contractor shall remove, replace, or otherwise correct all unacceptable work as directed by the City at the expense of the Contractor, without cost or liability to the City.
- C. Prior to Final Acceptance and upon written order by the City, the Contractor shall remove or uncover unauthorized work. After examination, the Contractor shall rebuild the uncovered work to a condition conforming to the Contract at the expense of the Contractor and without cost or liability to the City. Any delay arising from unauthorized work shall be an inexcusable delay.
- D. Prior to Final Acceptance and upon written order by the City, the Contractor shall uncover un-inspected work. After examination, the Contractor shall rebuild the uncovered work to a condition conforming to the Contract.
 - 1. If the City determines that the un-inspected work is acceptable, the uncovering, removing, and rebuilding will be paid for as extra work and any delay resulting there from shall be an excusable delay.
 - 2. If the City reasonably determines that the un-inspected work is unacceptable, the uncovering, removing, and rebuilding shall be at the Contractor's expense and any delay resulting there from shall be an inexcusable delay.

2.3 PROTECTION AND RESTORATION OF PROPERTY AND LANDSCAPES

- A. The Contractor shall use every precaution to prevent injury or damage to wires, poles, or other property of public utilities; trees, shrubbery, crops, and fences along and adjacent to the right-of-way, all underground structures such as pipes and conduits, within or outside of the right-of-way; and the Contractor shall protect and carefully preserve all property marks until an authorized agent has witnessed or otherwise referenced their location.
- B. The Contractor shall be responsible for all damage or injury to property of any character, during the prosecution of the work, resulting from any act, omission, neglect, or misconduct in his manner or method of executing the work, or at any time due to defective work or materials, and said responsibility will not be released until the project shall have been completed and accepted.
- C. When or where any direct or indirect damage or injury is done to public or private property by or on account of any act, omission, neglect, or misconduct in the execution of the work, or as a result of the failure to perform work by the Contractor, the Contractor shall restore, at its own expense, such property to a condition similar or equal to that existing before such damage or injury was

GENERAL REQUIREMENTS (continued)

done, by repairing rebuilding, or otherwise restoring as may be directed, or the Contractor shall make good such damage or injury in an acceptable manner.

- D. The Contractor shall be responsible for the preservation of all trees and plants on the project which are not called to be removed. Any trees damaged by the Contractor's operations shall be repaired using approved tree dressing or paint in accordance with the appropriate provisions of Section 650-658 inclusive of the NHDOT Standard Specifications. Damaged trees must be replaced if so determined by the City Arborist, in his or her sole discretion.
- E. If the Contractor fails to repair, rebuild or otherwise restore such property as may be deemed necessary, the Owner, after 48 hours notice, may proceed to do so, and the cost thereof may be deducted from any money due or which may become due the Contractor under the contract.
- F. It is the intent of the Parties that the Contractor preserve, to as great an extent as possible, the natural features of the site.
- G. Construction operations on this project may unearth or uncover cultural resources of a historic nature. If buried or obscured cultural materials are observed during vegetation removal, the encountered resource shall then be identified, recorded and an assessment made of the resource by a qualified archaeologist.

The right is reserved to the City and its authorized agents, including a qualified archaeologist and appropriate professions to enter upon the right of way for the purposes of investigating and/or excavating and removing such resources. The contractor shall cooperate with forces engaged in such work and may be required to work on another area of the project until the evaluation is completed.

2.4 MAINTENANCE DURING CONSTRUCTION

- A. The Contractor shall maintain the work during construction and until the project is accepted. This maintenance shall constitute continuous and effective work prosecuted day by day, with adequate equipment and workers to ensure that the structure is kept in satisfactory conditions at all times.

2.5 SAFETY PRECAUTIONS

- A. Upon commencement of work, the Contractor shall be responsible for initiating, maintaining and supervising all safety precautions necessary to ensure the safety of employees on the site, other persons who may be affected thereby, including the public, and other property at the site or adjacent thereto.
- B. During the progress of the Work Contractor shall keep the Site and other areas free from accumulations of waste materials, rubbish, and other debris. Removal and

disposal of such waste materials, rubbish, and other debris shall conform to applicable Laws and Regulations.

- C. At the end of each working day, the construction site shall be left in a safe and orderly manner. All materials and equipment on site that have not been incorporated into the work shall be placed in secured areas outside the traveled way and off private property, unless the Contractor has obtained agreements with said property owners for storage of materials and equipment. Portions of the work which are in progress shall be protected to avoid damage to the work and/or protect pedestrians and vehicles utilizing the project area.

2.6 PERMITS

- A. It will be the responsibility of the Contractor to obtain all permits required for the operation of equipment in, or on, all city streets and public ways.

2.7 MAINTENANCE AND PROTECTION OF TRAFFIC

- A. The Contractor shall provide traffic flaggers as the City Engineer deems necessary for the direction and control of traffic within the street if necessary for the delivery of materials. The Contractor shall not park vehicles in the no parking areas in front of the site unless allowed by the City.
- B. The Contractor shall be responsible for the cost, scheduling and supervising of any necessary Traffic Officers. Traffic flaggers are subsidiary to the mobilization (692) item.
- C. The contractor shall be responsible to ensure the safe passage of pedestrians thru the work area at all times. At least one (1) pedestrian access shall be provided at all times.

BARRICADES AND WARNING SIGNS

- D. The Contractor shall provide, erect and maintain all necessary barricades, suitable and sufficient lights, danger signals, signs and other traffic control devices, and shall take all necessary precautions for the protection of the work and safety of the public.
- E. The Contractor shall be held responsible for all damage to the work due to any failure of the warning devices to properly protect the work from the traffic, pedestrians or other causes.
- F. Areas closed to traffic shall be protected by effective barricades.
 - 1. Obstructions shall be illuminated during hours of darkness.
 - 2. Suitable warning signs shall be provided to control and direct traffic in a proper manner, as approved by the engineer.

2.8 LIMITATION OF OPERATIONS

- A. The Contractor shall not open up work to the prejudice or detriment of work already started.

GENERAL REQUIREMENTS (continued)

PART 3 - TEMPORARY FACILITIES

3.1 STORAGE FACILITIES

- A. The Contractor shall not store materials or equipment in a public right-of-way beyond the needs of one working day. Equipment and materials shall be stored in an approved location.
- B. The Contractor shall protect all stored materials from damage by weather or accident and shall insure adequate drainage at and about the storage location.
- C. Prior to final acceptance of the work all temporary storage facilities and surplus stored materials shall be removed from the site.

3.2 SANITARY FACILITIES

- A. The Contractor shall provide for toilet facilities for the use of the workers employed on the work.
- B. Temporary toilet facilities may be installed provided that the installation and maintenance conforms to all State and local laws, codes, regulations and ordinances governing such work. They shall be properly lit and ventilated, and shall be kept clean at all times.
- C. Prior to final acceptance of the work all temporary toilet facilities shall be removed from the site.

3.3 TEMPORARY WATER

- A. The Contractor shall make all arrangements with the local water department for obtaining water connections to provide the water necessary for construction operations and shall pay all costs.

3.4 ELECTRICITY

- A. The Contractor shall be responsible with obtaining an electrical permit from the City Electrical Inspector.

GENERAL REQUIREMENTS (continued)

PART 4 - MEASUREMENT AND PAYMENT

4.1 MEASUREMENT OF QUANTITIES

- A. This project will be bid by the unit price as shown on the proposal page.

4.2 SCOPE OF PAYMENT

- A. The Contractor will provide a schedule of values to be approved by the Engineer and used for purposes of partial payments.
- B. The Contractor shall receive and accept compensation provided for in the contract as full payment for furnishing all materials and for performing all work under the contract in a complete and acceptable manner and for all risk, loss, damage or expense of whatever character arising out of the nature of the work or the prosecution thereof.
- C. The Contractor shall be liable to the Owner for failure to repair, correct, renew or replace, at his own expense, all damage due or attributable to defects or imperfections in the construction which defects or imperfections may be discovered before or at the time of the final inspection and acceptance of the work.
- D. No monies, payable under the contract or any part thereof, except the first estimate, shall become due or payable if the Owner so elects, until the Contractor shall satisfy the Owner that the Contractor has fully settled or paid all labor performed or furnished for all equipment hired, including trucks, for all materials used, and for fuels, lubricants, power tools, hardware and supplies purchased by the Contractor and used in carrying out said contract and for labor and parts furnished upon the order of said Contractor for the repair of equipment used in carrying out said contract; and the Owner, if he so elects, may pay any and all such bills, in whole or in part, and deduct the amount of amounts so paid from any partial or final estimate, excepting the first estimate.

4.3 COMPENSATION FOR ALTERED QUANTITIES

- A. Except as provided for under the particular contract item, when the accepted quantities of work vary from the quantities in the bid schedule the Contractor shall accept as payment in full, so far as contract items are concerned, at the original contract unit prices for the accepted quantities of work done. No allowance will be made for any increased expense, loss of expected reimbursement, or loss of anticipated profits suffered or claimed by the Contractor resulting either directly from such alterations or indirectly from unbalanced allocation among the contract items of overhead expense on the part of the Bidder and subsequent loss of expected reimbursements therefore or from any other cause.
- B. Extra work performed will be paid for at the contract bid prices or at the price negotiated between the Owner and the Contractor if the item was not bid upon. If

no agreement can be negotiated, the Contractor will accept as payment for extra work, cost plus 15% (overhead and profit). Costs shall be substantiated by invoices and certified payroll.

4.4 FINAL ACCEPTANCE

- A. Upon due notice from the Contractor of presumptive completion of the entire project, the City Engineer will make an inspection. If all construction provided for and contemplated by the contract is found complete to his satisfaction, this inspection shall constitute the final inspection and the City Engineer will make the final acceptance and notify the Contractor in writing of this acceptance as of the date of the final inspection.
- B. If, however, the inspection discloses any work in whole or in part, as being unsatisfactory, the City Engineer will give the Contractor the necessary instructions for correction of such work and the Contractor shall immediately comply with and execute such instructions. Upon correction of the work, another inspection will be made which shall constitute the final inspection provided the work has been satisfactorily completed. In such event, the City Engineer will make the final acceptance and notify the Contractor in writing of this acceptance as of the date of final inspection.

4.5 ACCEPTANCE AND FINAL PAYMENT

- A. When the project has been accepted and upon submission by the Contractor of all required reports, completed forms and certifications, the Owner will review the final estimate of the quantities of the various classes of work performed. The Contractor may be required to certify that all bills for labor and material used under this contract have been paid.
- B. The Contractor shall file with the Owner any claim that the Contractor may have regarding the final estimate at the same time the Contractor submits the final estimate. Failure to do so shall be a waiver of all such claims and shall be considered as acceptance of the final estimate. All prior partial estimates and payments shall be subject to correction in the final estimate and payment.

4.6 GENERAL GUARANTY AND WARRANTY OF TITLE

- A. The Contractor unconditionally warrants and guarantees that the project will be free from warranty defects for one year from the date of Final Acceptance. Final Acceptance includes receipt of all conforming closeout documentation.
- B. If the City discovers any warranty defects during the warranty period, the Contractor agrees to promptly perform all remedial work at no additional cost or liability to the City. The Contractor shall promptly remedy any defects in the work and pay for any damage to other work resulting there from which shall appear within a period of twelve (12) months from the date of final acceptance of the work. The Owner will give notice of defective materials and work with reasonable promptness.

- C. Neither the final certification of payment nor any provision in the contract nor partial or entire use of the improvements embraced in this Contract by the Owner or the public shall constitute an acceptance of work not done in accordance with the Contract or relieve the Contractor of liability in respect to any express or implied warranties or responsibility for faulty materials or workmanship.
- D. No material, supplies or equipment to be installed or furnished under this Contract shall be purchased subject to any chattel mortgage or under a conditional sale, lease purchase or other agreement by which an interest therein or in any part thereof is retained by the Seller or supplier. The Contractor shall warrant good title to all materials, supplies and equipment installed or incorporated in the work and upon completion of all work, shall deliver the same together with all improvements and appurtenances constructed or placed thereon by him to the Owner free from any claims, liens or charges. Neither the Contractor nor any person, firm or corporation furnishing any material or labor for any work covered by this Contract shall have the right to a lien upon any improvements or appurtenances thereon.
- E. Nothing contained in this paragraph, however, shall defeat or impair the right of persons furnishing materials or labor to recover under any bond given by the Contractor for their protection or any rights under any law permitting such persons to look to funds due the Contractor in the hands of the Owner. The provisions of this paragraph shall be inserted in all subcontractors and material contracts and notice of its provisions shall be given to all persons furnishing materials for the work when no formal contract is entered into for such materials.

4.7 NO WAIVER OF LEGAL RIGHTS

- A. Upon completion of the work, the Owner will expeditiously make final inspection and notify the Contractor of acceptance. Such final acceptance, however, shall not preclude or stop the Owner from correcting any measurement, estimate, or certificate made before or after completion of the work, nor shall the Owner be precluded or be stopped from recovering from the Contractor or his Surety, or both, such overpayment as it may sustain by failure on the part of the Contractor to fulfill his obligations under the contract.

A waiver on the part of the Owner of any breach of any part of the contract shall not be held to be a waiver of any other or subsequent breach.

- B. The Contractor, without prejudice to the Contract shall be liable to the terms of the Contract, shall be liable to the Owner for latent defects, fraud or such gross mistakes as may amount to fraud, and as regards the Owner's right under any warranty or guaranty.

4.8 TERMINATION OF CONTRACTOR'S RESPONSIBILITY

- A. Whenever the improvement provided for by the Contract shall have been completely performed on the part of the Contractor and all parts of the work have been released from further obligations except as set forth in his bond and as provided in Article 4.8 above.

SPECIAL REQUIREMENTS

5.1 PRECONSTRUCTION CONFERENCE

- A. A conference will be held at a specified location by the City, within ten (10) days after the awarding of the contract. At this time, the contractor will be required to submit a schedule and a plan showing project activities.
 - 1. In addition to the contractor any subcontractors are required to attend.
 - 2. City and NHDOT officials involved in the project will be present at this meeting.

- a) It is the purpose of this meeting to inform the various agencies of the proposed work schedule, and to give them the opportunity of discussing any difficulties and of offering suggestions to the Contractor concerning his proposed schedule in order that full cooperation may be reached.

5.2 SCHEDULE OF OPERATIONS

- A. The above mentioned schedule of operations shall consist of a bar chart detailing the Work Plan/Sequence of Construction

5.4 WORKING HOURS

- A. No work shall proceed on this project prior to the hour of 7:00 A.M. or after 7:00 P. M. (prevailing time) on any working day without written approval from the Engineer. The definition of work for this specification shall include the starting or moving of equipment, machinery, or materials. No Work Shall be completed on Saturday, Sundays or Holidays.

- B. Any day worked for four hours or more shall be considered a full working day.

5.5 NOTIFICATION OF RESIDENTS

- A. Residents shall be notified sufficiently in advance of any construction affecting the resident's driveway and sidewalk to allow adequate time for his removal of personal vehicles.

5.6 MATERIALS

- A. Materials shall meet the requirements specified for the various subsections of the specifications. Equals shall be approved only prior to the bid opening.

5.7 OCCUPATIONAL SAFETY AND HEALTH

- A. The Contractor is hereby advised that all work to be furnished to the City shall be performed with equipment, methods, and use of personnel in conformance with the pertinent Occupational Safety and Health Act requirements of the State of New Hampshire and with the regulations for construction as specified by the City of Labor and Occupational Safety and Health Administration (OSHA) as currently amended.

5.8 WASTE MATERIAL

- A. All waste material shall be removed from the site and the area left clean upon completion of work.
- B. Any equipment or structures damaged by the Contractor shall be repaired or replaced at no additional cost to the City.

5.15 QUALITY ASSURANCE

- A. The Contractor shall be responsible at all times for maintaining quality assurance during performance of his work in accordance with the NHDOT Standard Specifications.

6 DRAWINGS

6.1 SHOP DRAWINGS

- A. The Contractor shall submit working and detail drawings, well in advance of the work, to the City Engineer for review.
- B. The Contractor's drawings shall consist of shop detail, erection and other working plans showing dimensions, sizes and quality of material, details and other information necessary for the complete fabrication and erection of the pertinent work.
- C. The Contractor shall submit two sets of drawings to the City Engineer.
- D. Prior to the approval of the drawings, any work done or materials ordered for the work involved shall be at the Contractor's risk.
- E. One set of the drawings will be returned to the Contractor approved or marked with corrections to be made. After approval has been given, the Contractor shall supply the City Engineer with two sets of the revised detail working drawings.
- F. The City Engineer's approval of the Contractor's working drawings will not relieve the Contractor from responsibility for errors in dimensions or for incorrect fabrication processes, or from responsibility to complete the contract work.

6.2 RECORD DRAWINGS

- A. The Contractor shall keep daily records of all changes in the work, ties to all new service connections, and elevations of all inverts.
- B. Upon completion of the project, the Contractor shall deliver to the Engineering marked-up set of plans with all changes and required information indicated in red.
- C. Final payment will not be made until the Engineer receives the marked-up set of plans.

TECHNICAL SPECIFICATIONS

All work shall be completed in accordance with the NHDOT Standard Specifications for Road and Bridge Construction and the NHDOT Standard Plans for Road Construction, most recent editions. All state and federal contract requirements contained in the Division 100 – General Provisions of the NHDOT Standard Specifications for Road and Bridge Construction will apply to this project.

The following Supplemental Specifications and Special Provisions shall amend the Standard NHDOT Standard Specifications for Road and Bridge Construction. In case of conflicts, these Supplemental Specifications (1) and Special Provisions (2) shall take precedence and shall govern.

The above listed specifications are modified as set forth herein on the following pages.

Method of payment described in the Technical Specifications shall supersede any methods described in the referenced standard specifications. All payments shall be subject to the terms and methods of payment set forth in the General Requirements.

SPECIAL PROVISION SECTION 101

DEFINITIONS AND TERMS

101.22 Commissioner shall mean City of Portsmouth Department of Public Works Director

101.39 Department shall mean the City of Portsmouth Department of Public Works

101.43 Engineer shall mean the City of Portsmouth Department of Public Works or their representative.

101.48 Executive Council shall mean the City of Portsmouth City Council.

HARBORWALK PARK: PHASE 2
SUPPLEMENTAL TECHNICAL SPECIFICATIONS

2-18-15

INDEX

<u>DIVISION</u>		<u># OF PAGES</u>
Section 02000 -	Sitework	4
Section 02050 -	Removals	3
Section 02398 -	Timberwork	7
Section 02461 -	Wood Marine Piles	7
Section 02515 -	Unit Paving	4
Section 02760 -	Site Furnishings	3
Section 02800	Site Improvements	2
Section 05120 -	Structural Steel	3

SECTION 02000

SITWORK

PART 1.0 - GENERAL

1.1 REFERENCE STANDARDS

- A. Refer to other divisions of these specifications, other sections in this division, and drawings for related work, which may affect the work of this section.

The Contract Drawings indicate and show limits of construction for this project. These specifications specify material and work requirements for this project. Both are complementary to each other, and both shall be followed to properly complete the work.

All work included or ordered under this contract shall be done in conformity with these specifications, the applicable provisions of the State of NH Department of Transportation "Standard Specifications for Road and Bridge Construction", latest edition, hereinafter referred to as "Standard Specifications" or "NHDOT SSRBC", and the City of Portsmouth rules, and City regulations, codes, ordinances.

- B. Definitions:
- 1) Definition: Whenever the word "Owner" is referred to in the Specifications, it shall mean CITY OF PORTSMOUTH and it's authorized representatives.
 - 2) Definition: Whenever the word "Owner Representative" is referred to in the Specifications, it shall mean the local CITY OF PORTSMOUTH's authorized representative.
 - 3) Definition: Whenever the word "Engineer" is referred to in the Specifications, it shall mean Waterfront Engineers LLC., and it's authorized representatives.
- C. Titles to divisions and paragraphs in these specifications and in the notes on the drawings are for convenience, and shall not be taken as an exact, correct or completed segregation of materials and labor.
- D. No responsibility is assumed by the Engineer or the Owner for omissions or duplications by the Contractor or its subcontractors due to real or alleged error in arrangement of matter in this specification or on the drawings.

- E. Latest revisions of federal, state and reference standards/specifications shall be used where only the specification number without date or revision number is given in specifications.
- F. Measurement and payment clauses listed in state and reference standards/specifications are not applicable.

1.2 SPECIFICATIONS

If conflicts arise between any of the Specifications, the project manual specifications shall govern, unless otherwise directed by the Engineer.

1.3 GENERAL

- A. Omissions from the plans and/or specifications of express reference to any labor or materials reasonably to be inferred there from and necessary for the proper execution of the work shall not relieve the Contractor or Subcontractor from furnishing them of a kind in keeping with the general character of the work.
- B. The Engineer shall decide all questions which may arise as to the quality, quantity, acceptability, fitness and rate of progress of the several kinds of work, and materials to be performed and furnished under the contract and shall decide all questions which may arise as to the fulfillment of the contract on the part of the Contractor. The Engineer's determination and decisions shall be final and conclusive.

1.4 PROJECT CONDITIONS

- A. It was not possible for the Owner and/or Engineer to observe all existing conditions in the completion of these documents. Unforeseen conditions are expected to be discovered. The accuracy of the existing conditions data is not guaranteed to the Contractor. During the execution of the work, it shall be the Contractor's responsibility to discover, identify and observe existing conditions not anticipated by the Construction Documents and promptly notify the Engineer of such conditions in writing and proposed solutions at no additional cost. The Contractor's bid shall anticipate delays associated with conflicts with existing utilities.
- B. Much of this work is in or near tidal water and the contractor shall assume that water levels will vary – schedule work accordingly.

1.5 ADDITIONAL RESPONSIBILITIES

A. PERMITS:

The following permits have been obtained. Contractor is responsible for familiarizing himself with the conditions of these permits and conducting all work in accordance with these permits:

- 1) NHDES Wetlands Bureau Permit approvals, 2014-01242
- 2) Army Corps of Engineers permit NAE-2014-02278

The Contractor shall obtain all permits required by local, state and federal governing authorities for removal and disposal of all demolition and waste materials.

B. UTILITIES:

The Contractor shall provide proper notices, make necessary arrangements and perform all other Service required for the removal or the care, protection, and maintenance of utilities, including, but not limited to: water, drainage, electric, telephone, wires, and all other items of this character above or below ground, on and around the site, assuming all responsibility and paying all costs related thereto. Related Service to any existing facilities shall not be disrupted without the prior approval of the Owner, and then only to the minimum extent required. The Contractor shall call *Digsafe at least 72 working day hours* in advance of any excavation, demolition, clearing/grubbing or other ground disturbance.

The Contractor shall comply with CITY OF PORTSMOUTH ordinances, rules and regulations.

C. JOB SITE LAYOUT, CONDITIONS AND MEASUREMENTS:

Contractor shall determine all lines and grades and field verify existing job conditions and measurements shown on the drawings. All discrepancies shall be reported to the Engineer for clarification. No additional compensation will be made to the Contractor for any error or negligence neither on its part, nor for discrepancies between actual conditions found at the site and as indicated in the Contract Documents after the work has commenced.

D. ROADS AND ACCESS TO THE SITE:

Access to the site for workmen and the delivery or removal of construction materials and/or equipment shall be made only from locations approved by the Owner. Existing roads shall remain accessible to vehicles at all times, unless temporary closures are scheduled in advance with the

Owner. Contractor shall obtain hauling permits and route approvals from governing authorities as applicable.

E. MUD & DUST CONTROL:

- 1) Contractor shall continuously implement a mud & dust control program to minimize dust generation and prevent tracking of mud onto roadways.

F. RECORD DRAWINGS:

- 1) Contractor shall submit red line Record Drawings of all work on paper and in electronic format acceptable to the Owner and Engineer upon project completion and prior to final payment.

G. TRAFFIC REGULATIONS AND PARKING:

- 1) The Contractor shall provide adequate personnel, flagmen, signs, barricades and equipment to properly regulate traffic at times when the work interferes with the normal flow of traffic both on and off the site. Parking areas and roadways outside the limits of the contract shall be kept free of debris resulting from construction related traffic. If at any time the Engineer or the City of Portsmouth determines that additional traffic control personnel are required to execute the work, the Contractor shall provide additional personnel at no additional cost.

- End of Section -

SECTION 02050

REMOVALS

PART 1.0 - GENERAL

1.1 REFERENCES

- A. Refer to other divisions of these specifications, other sections in this division, and drawings for related work, which may affect the work of this section.
- B. The Contract Drawings indicate and show limits of construction for this project. These specifications specify material and work requirements for this project. Both are complementary to each other, and both shall be followed to properly complete the work.
- C. Definitions:
 - 1) Definitions: Whenever the word "Remove" is referred to in the Contract Documents, it shall mean removal from the project site including legal disposal by the contractor. Whenever the word "Salvage" is referred to in the Contract Documents, it shall mean the item being removed is to remain the property of the Owner and be delivered by the Contractor to a designated storage yard within the City.

1.2 SCOPE

- A. The work of this section consists of the removal, including legal disposal or salvage of materials shown to be removed/salvaged on the drawings as required for removal work, new construction, or relocation.

1.3 JOB CONDITIONS

- A. The Contractor shall inspect the premises prior to submittal of its proposal for verification of existing conditions, which will affect its work.
- B. Provide necessary protection to ensure the safe passage of persons around the area of removals. Conduct operations to prevent damage to adjacent buildings, structures, and other facilities as well as persons.
- C. Promptly repair damages caused to adjacent facilities by removal operations, as directed by the Owner and at no cost to the Owner.

1.4 PERMITS

- A. The Contractor shall obtain all permits required by local, state and federal governing authorities for removal and disposal of all removal materials.

1.5 DISPOSAL OF REMOVED MATERIALS

- A. At regular intervals, remove from the site all debris, rubbish, and other materials resulting from removal operations, and legally dispose of off the site. Storage or sale of removed materials to be removed will not be permitted on the site.
- B. Burning of removed materials will not be permitted on the site.
- C. Any removal/stockpiled materials/soils that are temporarily stored on site shall be protected from erosion and from causing sedimentation.
- D. Carefully remove, retain and store in a protected area under cover any items indicated to be salvaged, reused, or reinstalled.

1.6 CLEANING-UP

- A. Clean adjacent structures and improvements of all mud, dust, dirt, and debris caused by removal operations, as directed by Owner.
- B. Return remaining adjacent areas to existing condition prior to the start of removal work, unless otherwise noted.

PART 2.0 - MATERIALS

2.1 REMOVALS SCHEDULE

- A. Removals include, but may not be limited to structures, systems, etc., as indicated on the drawings:
Removals:
 - 1) Metals, wood, timber indicated to be removed within work areas.
Pull out or cut fence posts 2 inches below concrete surfaces.
 - 2) Existing surplus excavated material including soil, stone, concrete, pavement, debris.
 - 3) Existing Incidental items, such as existing concrete, metals, fabrics, timber, etc.Salvage:
 - 1) Existing chain link fence – to remain property of the owner.

PART 3.0 - EXECUTION

3.1 DETAILS OF WORK

- A. All removal materials shall be taken from the site by the Contractor and unless otherwise noted or directed by the Owner, will become its property. None of the removal materials shall be reused in the new permanent construction unless specifically noted on the plans or specifications or approved in writing by the Owner. All materials removed from the site shall be legally disposed of.
- B. Existing items salvaged for reuse shall be handled and stored carefully with adequate contractor indexing for reinstallation. The stored materials shall be protected from theft. Reinstall these items in the same locations in-kind, unless otherwise specified.
- C. The Contractor shall provide adequate construction fencing for protection of the area and monitoring of construction fence openings to ensure the public does not enter the construction/work areas.
- D. The contractor shall immediately retrieve debris that falls onto the intertidal area/water and shall maintain adequate equipment at the site to perform such retrieval.

- End of Section -

SECTION 02398

TIMBERWORK

PART 1- GENERAL

1.1 REFERENCES

- A. Refer to other divisions of these specifications, other sections in this division, and drawings for related work, which may affect the work of this section.
- B. The Contract Drawings indicate and show limits of construction for this project. These specifications specify material and work requirements for this project. Both are complementary to each other, and both shall be followed to properly complete the work.

1.2 DESCRIPTION OF WORK

A. Work Included: The Contractor shall provide the labor, materials and equipment necessary to complete the Work of this Section, including but not limited to the following:

- 1. Timber overlook construction
- 2. Incidental timberwork

1.3 SUBMITTALS

A. Certificates: Certificates of conformance of timber, including grade certificates and Lacey Act Amendment declaration form, and vendor certificate of Ipe grade and quality shall be submitted to the Engineer.

B. Manufacturer's Catalog Data including installation instructions if appropriate

Spike grids
FRP angles
Screws
Timber bolts
Membrane
Glue-lams
Ipe decking, plugs, screws, wax
Adhesive
Copper Napthenate
Stain

C. References

Submit 2 reference letters from prior governmental owners indicating successful completion of marine timberwork projects of similar nature and complexity, which did require tidal work and good fit and finish.

1.4 QUALITY ASSURANCE

A. Treated timber shall be grade stamped and tagged with treatment information. The supplier's certificate of specification conformance shall be submitted and additional producer data and material testing may be required at Contractor cost if the material delivered does not have adequate certificates or does not appear to meet the specifications.

1.5 REFERENCE STANDARDS

A. AMERICAN INSTITUTE OF TIMBER CONSTRUCTION (AITC)

AITC 109 Standard for Preservative Treatment of Structural Glued Laminated Timber

AITC 111 Recommended Practice for Protection of Structural Glued Laminated Timber During Transit, Storage and Erection

AITC 117 Standard Specifications for Structural Glued Laminated Timber of Softwood Species, Design and Manufacturing Requirements

B. AMERICAN SOCIETY FOR TESTING AND MATERIALS (ASTM)

ASTM A 36 Carbon Structural Steel

ASTM A47 Ferritic Malleable Iron Castings

ASTM A 123 Zinc (Hot-Dip Galvanized) Coatings on Iron and Steel Products

ASTM A 153 Zinc Coating (Hot-Dip) on Iron and Steel Hardware

ASTM A 307 Carbon Steel Bolts and Studs. 60,000 psi Tensile Strength

ASTM D638 Standard Test Method for Tensile Properties of Plastics

ASTM D695 Standard Test Method for Compressive Properties of Rigid Plastics

ASTM D2344 Standard Test Method for Short-Beam Strength of Polymer Matrix Composite Materials and Their Laminates

ASTM D3737 Standard Practice for Establishing Allowable Properties for Structural Glued Laminated Timber (Glulam)

C. AMERICAN WOOD-PRESERVERS' ASSOCIATION (AWPA)

AWPA M4 Care of Preservative-Treated Wood Products

AWPA P5 Standard for Waterborne Preservatives

AWPA U1 Use Category System: User Specification for Treated Wood

PART 2 - PRODUCTS

2.1 MATERIALS

A. Timber

1. All timber (except Ipe) shall be preservative treated No. 2 Dense Southern Yellow Pine or better, unless otherwise specified.

All timber below deck level is for salt water marine use in tidal and splash zones shall be pressure treated with chromated copper arsenate (CCA) conforming to AWWA Standard P5. The treatment shall be by the full cell process in accordance with AWWA Standards. All CCA timber shall be treated to 2.5 pounds per cubic foot minimum retention, except glue-lam timbers which shall be 0.6 pcf CCA. Bond glued-laminated members with a waterproof adhesive conforming to the test requirements of ASTM D3737 for waterproof glue, shear strength and durability.

Decking shall be nominal 2x6 Ipe, toe board 2x4 Ipe, FEQ grade with first quality one face and better, S4S, E4E 1/8" radius. All lumber is to be supplied with the ends sealed with "Anchorseal", Paraffin or approved wax end sealer. All lumber must be resealed after cutting to reduce end splits. The exposed face and edge corners shall have good appearance and physical characteristics with clear all heart wood, no unsound defects, no warping, no twisting, no sap wood, no checks and no milling defects.

Appearance Characteristics

- 1) Color variation
- 2) Mixed grain
- 3) Drying checks
- 4) Reverse/Roey Grain
- 5) Birdseye
- 6) Pin knots
- 7) Maculas (Birds Eye)
- 8) Water stain
- 9) Discoloration
- 10) Sticker marks
- 11) Molder knife marks

Milling Defects

- 1) Skip
- 2) Torn grain
- 3) Chipped grain
- 4) Non compliant profiling

Physical Characteristics

- 1) Bow
- 2) Crook
- 3) Cup
- 4) Twist
- 5) Raised grain

Sound Defects

- 1) Pin holes
- 2) Sound knots

Unsound Defects

- 1) Large borer holes
- 2) Splits
- 3) Unsound knots
- 4) Shake
- 5) Sapwood

Ipe must be verified of legal origin and compliance as being, legally harvested, transported, exported, imported and documented in compliance with all country of origin, international and domestic laws, rules, regulations and treaties pertaining to the fair and legal trade of forest products including the U.S. Department of Agriculture Lacey Act, ITTA (International Tropical Timber Trade Agreement).

Lumber supplied shall meet or exceed the Static Coefficient of Friction for both Neolite

and Leather in accordance with ASTM C1028-89 standard testing method as follows:

Neolite - Dry .55 FP / Wet .79 FP

Leather – Dry .73 FP / Wet .69 FP

Lumber supplied shall meet or exceed International Building Code/International Residential Code requirements for “Naturally Durable Wood” being durability rated by the U.S Forest Products Laboratory or the Forest Research Laboratory Oregon State University as Class 2 or better.

Ipe (Tabebuia spp, Lapacho Group) – Class 1

B. Galvanized Hardware

All timber hardware, including bolts, nuts, washers, straps, plates, spikes and drift pins shall be hot-dip galvanized steel, or stainless steel, conforming to the respective ASTM Standards and other requirements specified below:

1. Bolts, Threaded Rod and Nuts: matching, to ASTM A307 or A193 B7 or F1554.
2. Washers, straps, plates and miscellaneous items shall be A36, A572 or A992 steel. Round washers shall be used where countersunk. Plates and clip angles shall be fully fabricated, including welding, drilling, punching and bending, before hot dip galvanizing.
3. Spike grids, hot dip galvanized malleable iron to ASTM A47.
4. Galvanizing shall be in accordance with ASTM A123 and A153, as applicable.

C. Stainless Steel Hardware

1. Decking screws shall be stainless steel #14 x 4.5” as recommended by the Ipe supplier.
2. Stringer to stringer screws shall be 5/16” dia. x 5”, such as GRK Pheinox RSS stainless steel or approved equal.
3. Stringer to fascia/ranger screws shall be 3/8” dia. x 8”, such as GRK Pheinox RSS stainless steel or approved equal.
4. Smaller frp clip angle screws shall be 1/4” dia. x 2.5”, such as GRK Pheinox RSS stainless steel or approved equal.

D. Miscellaneous

1. Field touch up coating (except Ipe) shall be copper naphthenate (1% min. metallic copper).

2. Membrane shall be a rubberized asphalt self-adhering membrane such as WR Grace, Ice & Water Shield or approved equal.

3. Adhesive shall be PL400 by Loctite, or approved equal.

4. FRP shapes:

Fiberglass Reinforced Plastic (FRP) manufacturer is required to have a minimum of 10 years experience in manufacturing FRP products. Fiberglass reinforcement is to be a combination of continuous roving, continuous strand mat, bi-directional roving mat and surfacing veil in sufficient quantities as required by the application and/or physical properties. Make all finished surfaces of FRP items smooth, resin-rich, free of voids and dry spots, cracks, crazes or unreinforced areas. Provide system which is completely covered with resin protection against exposure due to wear, weathering, and ultraviolet light damage. All FRP products shall be manufactured using a pultruded process utilizing polyester or vinyl ester resin with ultraviolet (UV) inhibitor additives. A synthetic surface veil fabric shall encase the glass reinforcement.

Fiberglass Pultruded Material Properties

Minimum Ultimate Coupon Properties:

	ASTM	
Tensile Stress, LW	D638	30,000 psi
Tensile Stress, CW	D638	7,000 psi
Compressive Stress, LW	D695	30,000 psi
Compressive Stress, CW	D695	15,000 psi
Short Beam Shear, LW	D2344	4,500 psi

LW = Lengthwise
CW = Crosswise

PART 3 - EXECUTION

A. Timber shall be carefully handled without sudden dropping, breaking of outer fibers, bruising or penetrating the surface with tools. It shall be handled with rope slings. Cant hooks, peaveys, pikes or hooks shall not be used. If visible, install timber with the best side showing.

B. Timber shall be closely fitted, accurately set to required lines, pitch and levels, and rigidly secured in place, as shown on the drawings. Cut and frame lumber and timber so that joints will fit over contact surface. Secure timbers and piles in alignment. Open joints are unacceptable. If pile head, pile cap and stinger bearing surfaces are not fully bearing, these bearing surfaces shall be shimmed with plastic flat and tapered shims to create full bearing – secure all shims.

The following requirements shall be met:

1. Holes for through bolts/threaded rod shall be 1/32” over actual bolt diameter, and no

more than 1/16" larger than bolt diameter and correctly aligned. Holes in Ipe decking shall match the size of the bolt/threaded rod/lag plus 1/32" to allow hand insertion with some friction, but no oversize gap and not a forced drive fit. The pilot hole for the threaded portion of the lag bolts shall have a diameter of 60% to 75% of the lag diameter to a depth corresponding to the installed thread depths. Prior to production pilot hole drilling, provide a sample lag installation with selected shank hole and thread pilot hole size into a sample piece of matching SYP timber, perpendicular to grain, with a standard washer, to demonstrate torque development sufficient to crush into timber under washer without damage to lag or pullout from pilot hole. Lags shall be lubricated with Vaseline or similar lubricant to reduce installation friction.

2. Timber dock washers shall be placed under both bolt heads (except timber bolt heads) and nuts.
3. Where damaged or cut for fitting, or during handling, treated timber shall be given two brush coats (at least 15 minutes apart) of copper naphthenate solution (min. 1% metallic copper) at the time of cutoff or drilling; before the cut surface is submerged by the tide.
4. Exposed edges of timber cap ends (excluding splices) shall be finished with a 3/4" chamfer all around unless otherwise noted.
5. Built-up timbers, such as pile caps and rangers (excluding glue-lams) shall be adhesive bonded using PL400 by Loctite, or approved equal, in dry conditions and with dry lumber, using bolts, assembly screws and/or clamps to pull the timbers together.
6. Stringers: Place crown up and, if possible, the better edge of deck stringers down. Tops of stringers shall not vary from a plane more than will permit bearing of the decking on the stringers.
7. Membrane shall be used to cover piles, pile caps, stringers, rangers, fascia and the seawall seat in a continuous water tight manner. Where uniform bearing is necessary, such as on stringer and fascia tops, tight butt joint pieces of membrane, rather than overlap. The membrane shall hang over the timber edges 3/4" in a straight and uniform manner.
8. Ipe decking shall be installed in accordance with the suppliers recommendations, including plank end wax treatments, screw end/edge and countersink distances, stagger joints and matching Ipe plug installation, neat and flush with top of decking. All decking/stringer intersections, excluding additional mooring fitting stringers, shall have 2 equally spaced screws installed, with plugs. Decking butt joints shall be tight and receive at least 2 screws per plank. Decking angle cut ends at the seawall shall be fastened with at least 3 equally spaced screws installed, with plugs set with recommended adhesive.
9. Bracing shall be installed with suitable hot dip galvanized square spike grids at all connections using the recommended tools to obtain the required penetration.

10. FRP: all field cut edges and abrasions shall be sealed with a catalyzed resin compatible with the original resin as recommended by the manufacturer.

- End of Section -

SECTION 02461

WOOD MARINE PILES

PART 1- GENERAL

1.1 REFERENCES

A. Refer to other divisions of these specifications, other sections in this division, and drawings for related work, which may affect the work of this section.

B. The Contract Drawings indicate and show limits of construction for this project. These specifications specify material and work requirements for this project. Both are complementary to each other, and both shall be followed to properly complete the work.

1.2 DESCRIPTION OF WORK

A. Work Included: The Contractor shall provide the labor, materials and equipment necessary to complete the Work of this Section, including but not limited to the following:

Overlook piles: timber support piles and timber fender piles

B. Related Work: The following items are not included in this Section and will be performed under the designated Sections:

1. SECTION 02398 - TIMBERWORK

1.3 QUALITY ASSURANCE

A. Preservative Treated Piles - Timber

The Contractor shall be responsible for the quality of treated wood products. The Contractor shall provide the Engineer with a certificate that the piles comply with applicable grade and AWPA standards. Identify treatment on each piece. The supplier's certificate of specification conformance shall be submitted and additional producer data and material testing may be requested if the material delivered does not appear to meet the specifications.

1.4 SUBMITTALS

1. Certificates of Conformance of the piles to these specifications shall be submitted to the Engineer for approval.

2. Manufacturer's Catalog Data

Pile shoes

Tie straps

3. Records

Submit pile driving records within 15 calendar days after completion of driving.

4. References

Submit 2 reference letters from prior governmental owners indicating successful completion of marine pile driving projects of similar nature and complexity, which did require pile capacity monitoring, pile driving records and good alignment.

1.5 REFERENCE STANDARDS

The publications listed below form a pan of this specification to the extent referenced. The publications are referred to in the text by the basic designation only.

A. AMERICAN SOCIETY FOR TESTING AND MATERIALS (ASTM)

ASTM D 25 Round Timber Piles

B. AMERICAN WOOD-PRESERVERS' ASSOCIATION (AWPA)

AWPA M4 Care of Preservative-Treated Wood
Products

AWPA M6 Brands Used on Forest Products

1.6 DELIVERY, STORAGE, AND HANDLING

A. Store piles in accordance with AWPA M4.

PART 2- PRODUCTS

2.1 MATERIALS

A. Timber piles shall meet the following requirements:

1. Timber fender piles shall conform to ASTM D 25, 8 inch tip Natural Taper.

2. Piles shall be Southern Yellow Pine, ASTM D 25, Class B, clean-peeled, treated with chromated copper arsenate (CCA) in accordance with AWPA. CCA shall conform to AWPA P5. The retention of preservative shall not be less than 2.5 pounds per cubic foot.

3. Piles shall be of sufficient lengths to include an allowance for cut-off of wood crushed or otherwise damaged during pile driving.

B. Timber pile appurtenances:

1. Bolts, threaded rod, nuts and washers shall conform to ASTM Standard A 307 and shall all be hot-dip galvanized in accordance with ASTM Standard A 123 or A 153.

2. Membrane & shims for pile head, see 02398.

3. Pile shoes shall be steel welded-plate point shoe especially fabricated for pile driving. Shoes shall be the product of a manufacturer regularly engaged in the manufacture of pile fittings. Provide size to fit pile tip. Fabricate boot type of 3/16 inch carbon steel fully welded, with at least three straps, each with three 3/16 inch nail holes. Fabricate welded-plate point type of four 3/16 inch or 1/4 inch steel plates, fully welded and sized to adequately cover full pointed area of pile; provide adequate provision for connection to the pile. Shoes may be furnished without coatings. Provide steel shoes on each pile.

PART 3-EXECUTION

3.1 INSTALLATION

A. All piles shall be driven in the locations shown within the tolerances required, and as shown on the Drawings. At cutoff elevation, butts shall be within 6 inches laterally and 6 inches longitudinally, of the location indicated before any manipulation. Manipulation force laterally to obtain correct location shall not exceed 200 pounds.

Piles shall be driven as shown on the Drawings. For support piles, the maximum allowable variation from the vertical is one-quarter inch per foot of pile length. Fender piles shall be installed with an outward 1:12 batter, tolerance 1/2" per foot.

The method used in driving piles shall not subject the piles to excessive or undue abuse producing crushing, injurious splitting, splintering, and brooming of the wood. Misaligned piles shall not be forced into proper position. Any pile damaged during driving by reason of internal defects, or by improper driving, or driven out of its proper location, or driven below the designated elevation shall be corrected by the Contractor without added compensation by providing second pile shall be driven adjacent to the defective pile.

B. Piles shall be driven by an approved gravity, diesel, steam, hydraulic, vibratory or air-driven hammer (or a combination). The hammer shall be in good condition and capable of operating in accordance with the manufacturers rating.

1. The contractor shall select a pile hammer correctly sized and capable of energy adjustment so as to avoid damage to the timber piles. For the last inch of penetration, the energy in foot-pounds shall not exceed numerically the tip diameter in inches multiplied by six thousand (6,000). Driving shall be stopped immediately when abrupt high resistance to penetration is encountered. Any sudden decrease in driving resistance shall be investigated with regard to the possibility of breakage of the pile; and if such sudden decrease in driving resistance cannot be correlated to boring data, and if the pile cannot be removed for inspection, it shall be considered an adequate reason for rejection of the pile.

2. Driving Resistance.

The Contractor shall record the driving resistance over the final 6 inches of driving until each pile reaches the required capacity as determined by the following formula:

$$R_u = 1.75 (E)^{1/2} \log(10N) - 100$$

R_u = ultimate pile resistance (kips)

E = rated hammer energy (ft-lb) based on ram stroke observed

N = number hammer blows at final penetration (blows per inch)

Working pile resistance shall be at least 10 tons, (35 tons ultimate by this equation). Alternatively, the contractor may submit a WEAP analysis for the equipment intended. Select and operate the pile hammer such that the acceptance blow criterion is between 1 and 10 blows per inch with a preferred target of 4 blows per inch.

C. Spudding may be used to penetrate fill, riprap or other obstructions if necessary to prevent damage to the piles.

D. Waterjetting of piles will not be permitted.

E. Predrilling at the pile locations will be permitted. The predrilling shall terminate five feet (5) below the obstruction layer. The diameter of the predrilled hole shall not exceed the minimum tip diameter specified for timber piles.

F. Special care shall be taken in setting and driving piles to prevent damage to adjacent work and existing structures.

G. Obstructions encountered in pile locations shall be dealt with as follows:

All rocks, timbers, pile stubs, or other obstructions at or near the ground surface (either above or under water) which interfere with driving of piles shall be moved at no additional cost to the Owner (reset any moved riprap).

H. Care shall be taken in driving to avoid subjecting piles to excessive or undue stress. Any pile driven in the wrong position or damaged by reason of defects, or by driving, shall be withdrawn and replaced by a new pile, or supplemented by a second pile adjacent to the first. In either case, no payment shall be made for the unacceptable pile. The contractor shall have the equipment necessary (such as a vibratory hammer) on site to drive the piles correctly as indicated and to be able to pull piles for redriving as necessary to meet the requirements.

I. After driving all piles in a given area, the heads of piles (except as hereinafter specified) shall be cut-off at the correct elevation, with the cut as indicated on the Drawings. A vertical deviation of not more than +1/4 or -1/2 inches from the correct cutoff elevations shown is permitted, but shims will be required to meet the correct elevation and the contractor is responsible to correct elevations by to the correct top of stringer elevation. The pile head shall be brush-coated with 2 coats (15 minutes apart min.) of copper naphthenate solution (min. 1% metallic copper) at the time of cutoff. Pile cut-offs shall remain the property of the Contractor and shall be removed from the site.

J. Care shall be used in handling timber piles to prevent damage. All treated piles shall be handled and installed in a manner that will avoid damage to the treated surfaces. The care and handling of treated piles shall conform to AWPA Standard M4 and to the additional requirements specified herein. Cant hooks, peavies, and end hooks shall not be used on side surfaces, and the use of pointed tools shall be confined to end grains. Pile tips shall be fitted with steel shoes to protect them in the driving operation. Driving and fitting shall meet the following requirements:

1. Piles fitted as shown on the Drawings, after driving.
2. Excessive manipulation of piles to force them into proper location is not permitted.

K. Installation Records: The Contractor shall keep a record, independent of that which may be made by the Engineer, of all pertinent data relative to the installation of piles. This record shall be available for the Engineers' inspection and shall be transmitted to the Engineer as they may be directed. The record (example following) for each pile shall include:

1. The dates and times of installation.
2. Kind and size of hammer; pressure, speed and efficiency at which operated.
3. Number of blows for each foot of penetration for the driven pile, for the last 10 feet of penetration.
4. Rate of penetration in blows per inch for the final six (6) inches.
5. Pertinent notes as to unusual behavior of the pile.

The monitoring of pile penetration during driving shall be set up to be directly readable by the engineer from a safe distance during pile driving with accurate and legible marks. If there is disagreement between the contractor and engineer on pile hammer performance and associated pile penetration counts/set, the engineer's decision is final and driving shall continue until acceptable criteria are met, or the contractor's means and methods may need to be adjusted to produce acceptable capacity data.

3.2 DAMAGED PILES

Driving of piles shall not subject them to damage. Piles which are damaged, split, broomed, or broken by reason of defects or by improper driving below cutoff elevation so as to impair them for the purpose intended shall be removed and replaced; a second pile may be driven adjacent thereto at the Contractor's expense. Minor damaged areas of treated piles shall be brush-coated with copper naphthenate solution (min. 1% metallic copper), two coats.

PART 4-PAYMENT

4.1 BASIS OF BIDS

Timber Piles

Base bids on the number and size of piles as indicated. The Contractor is responsible for ordering adequate lengths of piles, based on the test piles (3 minimum) driven by the contractor at representative locations around the overlook. Provide test pile length and bottom embedment data to the engineer. Test piles shall include a static tension pull up test up to a load of 2,000 pounds. Adjustment in contract price will not be made for cutting off piles, for any portion of a pile remaining above the cutoff elevation, or for broken, damaged, or rejected piles. The Contractor may drive more test piles at additional locations to aid in more precisely determining the pile lengths needed and the test piles will be accepted as production piles if in the correct locations and driven to the required capacity, as specified.

- End of Section

-PILE DRIVING LOG

CONTRACT NO. _____ CONTRACT NAME _____
 CONTRACTOR _____ TYPE OF PILE _____
 PILE LOCATION _____ PILE SIZE: BUTT/TIP: _____ LENGTH _____
 GROUND ELEVATION _____ CUT OFF ELEVATION _____
 PILE TIP ELEVATION _____ VERTICAL (____) BATTER 1 ON (____)
 SPLICES ELEVATION _____ COMPANY _____
 HAMMER: MAKE & MODEL _____ WT. RAM _____
 STROKE _____ RAM RATED ENERGY _____
 DESCRIPTION & DIMENSIONS OF DRIVING CAP _____
 CUSHION MATERIALS & THICKNESS _____
 INSPECTOR _____

"DEPTH" COLUMN OF PILE DRIVING RECORD REFERENCED TO:

_____ CUT-OFF ELEVATION
 TIME: START DRIVING _____ FINISH DRIVING _____ DRIVING TIME _____
 INTERRUPTIONS (TIME, TIP ELEV. & REASON) _____
 DRIVING RESISTANCE _____

DEPTH NO. OF DEPTH NO. OF DEPTH NO. OF
 FT. BLOWS FT. BLOWS FT. BLOWS

0	_____	18	_____	36	_____
1	_____	19	_____	37	_____
2	_____	20	_____	38	_____
3	_____	21	_____	39	_____
4	_____	22	_____	40	_____
5	_____	23	_____	41	_____
6	_____	24	_____	42	_____
7	_____	25	_____	43	_____
8	_____	26	_____	44	_____
9	_____	27	_____	45	_____
10	_____	28	_____	46	_____
11	_____	29	_____	47	_____
12	_____	30	_____	48	_____
13	_____	31	_____	49	_____
14	_____	32	_____	50	_____
15	_____	33	_____	51	_____
16	_____	34	_____	52	_____
17	_____	35	_____	53	_____

DRIVING RESISTANCE IN BLOWS PER INCH FOR LAST FOOT OF PENETRATION:

DEPTH _____ FT TO DEPTH _____ FT
 1" 2" 3" 4" 5" 6" 7" 8" 9" 10" 11" 12" _____
 ELEV. _____ ELEV. _____

REMARKS _____

CUT OFF ELEVATION: FROM DRAWING _____

TIP ELEVATION = GROUND ELEVATION - DRIVEN DEPTH = _____

DRIVEN LENGTH = CUT OFF ELEVATION - TIP ELEVATION = _____

SECTION 02515

UNIT PAVING

PART 1 - GENERAL

1.1 GENERAL REQUIREMENTS

Drawings and general provisions of Contract, including General and Supplemental Conditions and Division 1 Specification Sections apply to this section.

- A. Examine all other sections of the Specifications for requirements which affect work of this Section whether or not such work is specifically mentioned in this Section. See drawings for locations and details.
- B. Coordinate work with that of all other trades affecting, or affected by work of this section. Cooperate with such trades to assure the steady progress of all work under the contract.

1.0 RELATED DOCUMENTS

- A. Drawings and general provisions of Contract, including General and Supplementary Conditions and Division 1 Specification sections, apply to this Section.

1.2 SUMMARY

- A. Work in this section includes the following:
 - 1. Furnishing all materials, supplies, labor, equipment and performing all operations in connection with installation of sawn slab granite pavers referenced in this specification as "Unit Pavers", maintenance and protection of all adjoining planted and paved areas and clean-up.

Local Governing Authority and Code Requirements.
All Necessary Construction Permits.

1.3 REFERENCES

- A. American Society of Testing and Materials (ASTM)

1.4 SUBMITTALS

- A. Qualification data for firms and persons specified in "Quality Assurance" Article to demonstrate their capabilities and experience. Include list of completed projects with project names, project addresses, names of Architects, Engineers, Landscape Architects and/or Owners, plus other information specified.

1.5 QUALITY ASSURANCE

- A. Installer Qualifications: Engage an experienced Installer who has successfully completed unit paver installations similar in material, design, complexity and extent to that indicated for Project. Contractor shall show evidence of a minimum of ten years experience managing and constructing unit paving projects as described herein.

1.6 DELIVERY, STORAGE, AND HANDLING

- A. Protect unit pavers and Portland cement/grout during storage and construction against wetting by rain, snow, or ground water and against contamination from earth and other materials.
- B. Granite pavers are in storage will be provided by the Owner with pick up by the contractor.

1.7 PROJECT CONDITIONS

- A. Cold Weather Protection: Do not use frozen materials or materials mixed or coated with ice or frost. Do not build on frozen subgrade or setting beds. Remove and replace unit paver work damaged by frost or freezing.

PART 2 - MATERIALS

2.1 SAWN SLAB GRANITE UNIT PAVERS

- A. Granite pavers are in storage will be provided by the Owner with pick up by the contractor. Any pavers damaged by the Contractor shall be replaced by the Contractors at its cost.

1. Color: Deer Isle Granite; Natural warm gray color range

2.2 SEATING BLOCKS

- A. One seating block is in storage will be provided by the Owner with pick up and installation by the contractor.

2.3 NONSHRINK GROUT

A non-metallic non-shrink (no volume decrease) grout obtaining a minimum 28 day compression strength of 5,000 psi, conforming to ASTM C 1107. The grout shall be formulated consistent with the surface orientation and application. Non-shrink grout is required for setting base stone under "Tall" Bollards and under Seating blocks.

2.4 SETTING MATERIALS FOR SEATING BLOCK

- A. Leveling Course: Maximum 1 inch depth of 2 parts clean, washed natural or manufactured concrete sand to 1 part Portland cement. Sand shall be fine, sharp, nonplastic aggregate conforming to ASTM C 33. Portland cement shall be Type II conforming to ASTM 150 and for general use in construction .
- B. Sand for Joints: Joint sand shall be clean, washed natural or manufactured concrete sand of fine, sharp, non-plastic aggregate conforming to ASTM C 144.
- C. Polymeric Sand: Sand shall be Gator MAXX Sand Bond for concrete pavers, wetcast & natural stone specifically designed for drainage and non drainage base systems. Product manufactured by Alliance Designer Products Inc., 225 Blvd. Bellerose West, Laval, Quebec, Canada H7L6A1; TEL: 866-212-1611.

PART 3 - EXECUTION

3.1 INSTALLATION, GENERAL

- A. Do not use unit pavers with large chips, cracks, voids, discolorations, and other defects that might be visible or cause staining in finished work.
- B. Cut unit pavers with motor driven masonry saw equipment to provide clean, sharp, unchipped edges. Cut units to provide pattern indicated and to fit adjoining work neatly. Use full units without cutting where possible. Hammer cutting is not acceptable.
- C. Joint Pattern as indicated on the project drawings.
- D. Hand-tight Swept Joints: Where unit pavers are indicated without spaced joints, set unit pavers with hand tight joints; Joint tolerance 0'-1/4" maximum.
- E. Tolerances: Do not exceed 1/8 inch unit-to-unit offset from flush (lippage) and a tolerance of 1/8 inch in 10 feet from level or slope as indicated for finished surface of paving.

3.2 SEATING BLOCK INSTALLATION

- A. Verify location and layout of seating blocks relative to surrounding pavers and joint pattern.
- B. Align seating blocks along primary joint lines and cut underlying pavers to accept block profile. Confirm that adjoining blocks fit tight together along adjoining surfaces.
- C. Place non-shrink grout on bituminous concrete base to set seating block. Grout shall not exceed 1" in depth prior to placement.
- D. After placement on grout make sure seating surface is level in both directions and sides are plumb.
- E. Clean and remove excess grout from surfaces and joints of surrounding pavers.

3.3 REPAIR, POINTING, CLEANING, AND PROTECTION

- A. Remove and replace unit pavers that are loose, chipped, broken, stained, or otherwise damaged. Remove and replace unit pavers that do not match adjoining unit pavers as intended. Provide new unit pavers to match adjoining pavers and install in same manner as original, with same joint treatment to eliminate evidence of replacement.
- B. Upon completion of unit paver placement, all work shall be cleaned down removing dirt, cutting dust, stains and other defacements. Do not use wire brushes or acid solutions.
- C. Provide final protection and maintain conditions in a manner acceptable to Installer, which ensures completed work is without damage or deterioration at time of Substantial Completion.

- End of Section -

SECTION 02760
SITE FURNISHINGS

PART 1 - GENERAL

1.1 RELATED DOCUMENTS

- A. Drawings and general provisions of the Contract, including General and Supplementary Conditions and Division 01 Specification Sections, apply to this Section.

1.2 SUMMARY

- A. Section Includes:
 - 1. Bench Seats

1.3 STANDARD REFERENCE

- A. The Contract Drawings indicate and show limits of construction for this project. These Specifications specify material and work requirements for this project. Both are complementary to each other, and both shall be followed to properly complete the work. Plans shall govern over technical specifications.
- B. Reference is made to items and paragraphs of the 2010 edition, of "Standard Specifications for Road and Bridge Construction", State of New Hampshire Department of Transportation. References in this section to these Standard Specifications bear the prefix "NHDOT".

1.4 SUBMITTALS

- C. Product Data: For each type of product indicated.
 - 1. Straight, 6'-0" long, bench seats and custom fabricated radial bench seats.
 - 2. Radial backless bench at 6'-0" long @ 5.50' inside radius

PART 2 - PRODUCTS

2.1 BENCH SEATS

- A. Coordinate with the Project Plans for bench seat placement.
- B. Manufacturer: DuMor, Inc., Mifflintown, PA. 17059-0142; TEL: 800-598-4018

WEB: www.dumor.com

C. Materials:

1. Radial Bench Seat - Backless style, Model #92; Straight Benches Model #92 backless
2. Cast Iron supports
3. Bench Anchors – 1/2" dia. hot dip galvanized anchor bolts (through bolts with lag bolts at conflicts)

D. Finish/Color

1. Zinc rich epoxy primer then finished with Polyester powder coating
2. Color - Black

2.2 CUSTOM RADIAL BENCH SEATS

A. Coordinate with the Contract Drawings for bench seat placement.

B. Manufacturer: DuMor, Inc., Mifflintown, PA. 17059-0142; TEL: 800-598-4018
WEB: www.dumor.com

C. Materials:

1. Bench Seat - Custom radial version of the Backless bench style, Model #92
2. Inside arc radius shall be 5'-6" and outside arc length of 6.0'. Seat width and height to match dimensions of straight version.
3. Cast Iron supports
4. Bench Anchors – 1/2" dia. hot dip galvanized anchor bolts (through bolts with lag bolts at conflicts)

D. Finish/Color

1. Zinc rich epoxy primer then finished with Polyester powder coating
2. Color - Black

PART 3 - EXECUTION

3.1 EXAMINATION

A. Examine all areas of construction for site furnishings per the Contract Drawings.

3.2 PREPARATION

A. Prepare surfaces immediately before placing Site Furnishing.

3.3 BENCH SEATS

A. Install as indicated on the Contract Plans and confirm placements with the Engineer and Owner prior to bolt-down..

B. Assure they are positioned in a equal and balanced manner relative to geometry of Overlook Deck:

1. Radial Bench Seats: Radial layout relative to circular shape at end of Overlook. One seat is at 90 degrees to Base Line Axis and two seats are aligned with one side parallel to the Cross Axis Line.

2. Straight Bench Seats: Long axis of bench seats are installed parallel relative to Overlook pile caps and structural members under deck and have consistent offsets from the outside edges of the Overlook deck.

C. Anchor to overlook per manufacturer's recommendations using A307 hot dip galvanized bolts, washer and nuts in all legs.

- End of Section -

SECTION 02800

SITE IMPROVEMENTS

PART 1- GENERAL

1.1 REFERENCES

- A. Refer to other divisions of these specifications, other sections in this division, and drawings for related work, which may affect the work of this section.
- B. The Contract Drawings indicate and show limits of construction for this project. These specifications specify material and work requirements for this project. Both are complementary to each other, and both shall be followed to properly complete the work.

1.2 DESCRIPTION OF WORK

A. Work Included: The Contractor shall provide the labor, materials and equipment necessary to complete the Work of this Section including incidental site work.

1.3 SUBMITTALS

- A. Railing system shop drawings, coating system, anchoring system, shimming procedure.
- B. Mooring hardware catalog cuts.

PART 2 - PRODUCTS

2.1 MATERIALS

A. Railing

Ornamental Railing System shall be 42" high industrial grade, surface mounted, 2-rail balustrade with picket/baluster panel configuration as shown, galvanized with hot dip galvanized steel system with compatible black finish, using the ColorGalv15 system by Duncan Galvanizing of Everett MA, or approved equal (with equivalent warranty).

Rails, panels, posts, base plates and anchor bolts shall be fabricated to withstanding at minimum the loads specified in IBC 2009 at or below allowed stresses. Anchor bolts on land shall be stainless steel wedge anchors installed into epoxy resin coated hole (5/8"x7" min.) or stainless steel threaded rod, nuts, washers installed into epoxy resin with 4" minimum embedment into the concrete below the pavers and setting bed. Rail post mounting on timber shall be as shown, using hot dip galvanized lag bolts with stainless steel washers.

B. Short Bollards

Shall be CSB-9 by MacElroy, or S1189 by Schoellhorn-Albrecht, or approved equal with equivalent shape and dimensions.

C. Double Bitts

Shall be CSB-7 by MacElroy, or S1428 by Schoellhorn-Albrecht, or approved equal with equivalent shape and dimensions.

All mooring fittings shall be cast steel, with steel filler plates cut and seal welded to cover base gaps, cover post head core holes and unused nut pockets with all welds ground flush and smooth. The castings shall be free of pock marks, air voids, blow holes and other surface defects prior to coating. Coating shall be galvanized with hot dip galvanized steel system with compatible black finish, using the ColorGalv15 system by Duncan Galvanizing or approved equal (with equivalent warranty).

PART 3 - EXECUTION

3.1 GENERAL

3.1.1 Railings

- A. Provide railing system in accordance as specified with connections, including post base anchorage, to comply with IBC 2009 pedestrian guard code. Posts and panels shall be plumb to within 1/8" in 2 feet tolerance. All joints shall be true and smooth, with no incorrect fit gaps and with no burrs, sharp edges or protruding fasteners. Repair any coating damage in accordance with the coating manufacturer recommendations such that it matches and is consistent with the adjacent coating.
- B. The area under each base plate shimmed true with grout (on granite) or other approved non-corroding, non-decaying shim material. Shims shall not project out beyond base plates.

3.1.2 Mooring Fittings

- A. Install with four 3/4" dia. HDG anchor bolts in epoxy resin, minimum 5" embedment, or through bolts in timber as indicated, both with suitable washers to span any gaps and fit into nut pockets. Fill nut pockets after installation flush with black SikaFlex 2c SL or approved equal. Fill nut pockets in a single lift or with other suitable measures to avoid sealant delaminations, air pockets or other defects.

- End of Section -

SECTION 05120

STRUCTURAL STEEL

PART 1 - GENERAL

1.1 REFERENCES

The publications listed below form a part of this specification to the extent referenced. The publications are referred to in the text by the basic designation only.

AMERICAN INSTITUTE OF STEEL CONSTRUCTION (AISC)

AISC M013	Detailing for Steel Construction
AISC M016	ASD Manual of Steel Construction
AISC M017	Connections

AMERICAN SOCIETY FOR TESTING AND MATERIALS (ASTM)

ASTM A36	Carbon Structural Steel
ASTM A123	(Zinc (Hot-Dip Galvanized) Coatings on Iron and Steel Products
ASTM A153	Zinc Coating (Hot-Dip) on Iron and Steel Hardware
ASTM A193	Alloy-Steel and Stainless Steel Bolting Materials for High Temperature or High Pressure Service and Other Special Purpose Applications
ASTM A194	Carbon and Alloy Steel Nuts for Bolts for High Pressure or High Temperature Service, or Both
ASTM A 572	High-Strength Low-Alloy Columbium-Vanadium of Structural Steel
ASTM F436	Hardened Steel Washers

AMERICAN WELDING SOCIETY (AWS)

AWS D1.1	Structural Welding Code - Steel
----------	---------------------------------

1.2 SUBMITTALS

Submit the following:

Certificates
Steel

Bolts, threaded rod, nuts, railing materials
Catalog data for manufacturer items

PART 2 - PRODUCTS

2.1 STEEL

2.1.1 High-Strength Structural Steel

2.1.1.1 Low-Alloy Steel

ASTM A572 Grade 50; or A709 Grade 50, unless otherwise specified. Plate ASTM A36. Rod ASTM A108. Pipe ASTM A53.

2.2 STRUCTURAL STEEL ACCESSORIES

2.3.1 Welding Electrodes and Rods

AWS D1.1 E70XX low hydrogen for all structural welds. E60XX electrodes are permitted for non-structural seal welds.

2.3.2 Threaded rod, anchor bolts, nuts, washers

1. Bolts, threaded rod, anchor bolts, nuts, washers – stainless steel or hot dip galvanized as indicated.

2.3 GALVANIZING

ASTM A123 or ASTM A153, as applicable, unless specified otherwise galvanize after fabrication where practicable. All hot dip galvanized metals shall be touched up after installation or welding with standard cold galvanizing zinc coating.

2.4 FABRICATION

2.4.1 Surfaces

Surfaces to receive coatings or galvanizing shall be cleaned and prepared in accordance with the manufacturer's recommendations and shall include removal of all welding irregularities, flux and weld spatter. Surfaces to receive coatings shall have the edges and corners eased to 1/16" minimum.

PART 3 - EXECUTION

3.1 ERECTION

After final positioning of steel members, provide full bearing under base plates and bearing plates using non-shrink grout or shims. Place non-shrink grout in accordance with the manufacturer's instructions.

3.2 CONNECTIONS

Bolts, nuts, and washers shall be clean of dirt and rust, and threads lubricated with anti-seize coating for stainless steel and petrolatum for galvanized, prior to installation.

Any welded splices in steel members shall be full penetration groove welds unless otherwise noted.

3.3 WELDING

AWS D1.1, except use only E70XX low hydrogen electrodes. Grind exposed welds smooth as indicated. E60XX electrodes are permitted only for non-structural seal welds.

3.4 FIELD QUALITY CONTROL

3.4.1 Welds

AWS D1.1.

3.4.1.1 Visual Inspection

All welds shall be subject to review by the Engineer and if any weld does not appear in compliance with AWS D1.1, the contractor may be required to furnish the services of AWS-certified welder and/or AWS-certified welding inspector for inspection, testing, repair and verification at the contractors expense.

3.4.1.2 Nondestructive Testing

AWS D1.1. If more than 20 percent of welds made by a welder contain defects identified by visual observation and/or testing, then all welds made by that welder shall be tested by radiographic or ultrasonic testing, as approved by the Engineer. Retest defective areas after repair.

-- End of Section --

ATTACHMENTS

Davis Bacon Wage Requirements

The minimum wage rates from the U.S. Department of Labor are attached. Wage rates paid under this Contract shall not be less than the wage rates set forth on the attached General Decision. All provisions of the Davis Bacon Act and Contract Work Hours and Safety Standards Act (attached) shall apply.

General Decision Number: NH150016 01/02/2015 NH16

Superseded General Decision Number: NH20140016

State: New Hampshire

Construction Type: Heavy

County: Rockingham County in New Hampshire.

HEAVY CONSTRUCTION PROJECTS

Note: Executive Order (EO) 13658 establishes an hourly minimum wage of \$10.10 for 2015 that applies to all contracts subject to the Davis-Bacon Act for which the solicitation is issued on or after January 1, 2015. If this contract is covered by the EO, the contractor must pay all workers in any classification listed on this wage determination at least \$10.10 (or the applicable wage rate listed on this wage determination, if it is higher) for all hours spent performing on the contract. The EO minimum wage rate will be adjusted annually. Additional information on contractor requirements and worker protections under the EO is available at www.dol.gov/whd/govcontracts.

Modification Number Publication Date
0 01/02/2015

*** ELEC0490-003 06/01/2014**

	Rates	Fringes
ELECTRICIAN.....	\$ 27.75	17.45

SUNH2011-012 02/22/2011		

	Rates	Fringes
LABORER: Common or General.....	\$ 17.24	1.54
LABORER: Landscape.....	\$ 15.23	1.81
OPERATOR: Excavator.....	\$ 25.03	5.35
OPERATOR: Loader.....	\$ 24.31	5.69
TRUCK DRIVER.....	\$ 18.17	3.24

WELDERS - Receive rate prescribed for craft performing

operation to which welding is incidental.

=====

Unlisted classifications needed for work not included within the scope of the classifications listed may be added after award only as provided in the labor standards contract clauses (29CFR 5.5 (a) (1) (ii)).

The body of each wage determination lists the classification and wage rates that have been found to be prevailing for the cited type(s) of construction in the area covered by the wage determination. The classifications are listed in alphabetical order of "identifiers" that indicate whether the particular rate is a union rate (current union negotiated rate for local), a survey rate (weighted average rate) or a union average rate (weighted union average rate).

Union Rate Identifiers

A four letter classification abbreviation identifier enclosed in dotted lines beginning with characters other than "SU" or "UAVG" denotes that the union classification and rate were prevailing for that classification in the survey. Example: PLUM0198-005 07/01/2014. PLUM is an abbreviation identifier of the union which prevailed in the survey for this classification, which in this example would be Plumbers. 0198 indicates the local union number or district council number where applicable, i.e., Plumbers Local 0198. The next number, 005 in the example, is an internal number used in processing the wage determination. 07/01/2014 is the effective date of the most current negotiated rate, which in this example is July 1, 2014.

Union prevailing wage rates are updated to reflect all rate changes in the collective bargaining agreement (CBA) governing this classification and rate.

Survey Rate Identifiers

Classifications listed under the "SU" identifier indicate that no one rate prevailed for this classification in the survey and the published rate is derived by computing a weighted average rate based on all the rates reported in the survey for that classification. As this weighted average rate includes all rates reported in the survey, it may include both union and non-union rates. Example: SULA2012-007 5/13/2014. SU indicates the rates are survey rates based on a weighted average calculation of rates and are not majority rates. LA indicates the State of Louisiana. 2012 is the year of survey on which these classifications and rates are based. The next number, 007 in the example, is an internal number used in producing the wage determination. 5/13/2014 indicates the survey completion date for the classifications and rates under that identifier.

Survey wage rates are not updated and remain in effect until a new survey is conducted.

Union Average Rate Identifiers

Classification(s) listed under the UAVG identifier indicate that no single majority rate prevailed for those classifications; however, 100% of the data reported for the classifications was union data. EXAMPLE: UAVG-OH-0010 08/29/2014. UAVG indicates that the rate is a weighted union average rate. OH indicates the state. The next number, 0010 in the example, is an internal number used in producing the wage determination. 08/29/2014 indicates the survey completion date for the classifications and rates under that identifier.

A UAVG rate will be updated once a year, usually in January of each year, to reflect a weighted average of the current negotiated/CBA rate of the union locals from which the rate is based.

WAGE DETERMINATION APPEALS PROCESS

1.) Has there been an initial decision in the matter? This can be:

- * an existing published wage determination
- * a survey underlying a wage determination
- * a Wage and Hour Division letter setting forth a position on a wage determination matter
- * a conformance (additional classification and rate) ruling

On survey related matters, initial contact, including requests for summaries of surveys, should be with the Wage and Hour Regional Office for the area in which the survey was conducted because those Regional Offices have responsibility for the Davis-Bacon survey program. If the response from this initial contact is not satisfactory, then the process described in 2.) and 3.) should be followed.

With regard to any other matter not yet ripe for the formal process described here, initial contact should be with the Branch of Construction Wage Determinations. Write to:

Branch of Construction Wage Determinations
Wage and Hour Division
U.S. Department of Labor
200 Constitution Avenue, N.W.
Washington, DC 20210

2.) If the answer to the question in 1.) is yes, then an interested party (those affected by the action) can request review and reconsideration from the Wage and Hour Administrator (See 29 CFR Part 1.8 and 29 CFR Part 7). Write to:

**Wage and Hour Administrator
U.S. Department of Labor
200 Constitution Avenue, N.W.
Washington, DC 20210**

The request should be accompanied by a full statement of the interested party's position and by any information (wage payment data, project description, area practice material, etc.) that the requestor considers relevant to the issue.

3.) If the decision of the Administrator is not favorable, an interested party may appeal directly to the Administrative Review Board (formerly the Wage Appeals Board). Write to:

**Administrative Review Board
U.S. Department of Labor
200 Constitution Avenue, N.W.
Washington, DC 20210**

4.) All decisions by the Administrative Review Board are final.

=====

END OF GENERAL DECISION



ATTACHMENT 2 – Additional Requirements and forms required by the
NHDOT Local Public Agency Manual

06/24/08

Supercedes: 9/11/06, 12/5/90

WAGE RATES
FEDERAL AID PROJECTS

This proposal contains minimum wage determinations as specified by the U.S. Secretary of Labor. Copies of the attached wage determination(s) shall be posted on the bulletin board at the work site and furnished to employees upon request. Furthermore, the wage determination(s) shall be incorporated into all subcontract agreements.

If the Contractor, any subcontractor or lower-tier contractor intends to employ a classification of labor not listed in the attached determination(s), it shall submit a Request for Additional Work Classification(s) to the New Hampshire Department of Transportation, Labor Compliance Office at (603) 271-2467. The Contractor is responsible for ensuring that a Request is submitted for any additional classification of work to be employed by itself, any subcontractor or lower-tier contractor 3-4 weeks before the classification is utilized.

This contract is subject to the Work Hours Act of 1962, P.L. 87-581 and implementing regulations.

NOTICE TO ALL BIDDERS

In accordance with the section "NOTICE OF REQUIREMENT FOR AFFIRMATIVE ACTION TO ENSURE EQUAL EMPLOYMENT OPPORTUNITY (EXECUTIVE ORDER 11246)", the New Hampshire Department of Transportation has the authority and responsibility to notify the Office of Federal Contract Compliance Programs of the United States Department of Labor if they become aware of any possible violations of Executive Order 11246 and 41 Code of Federal Regulation Chapter 60.

The Office of Federal Contract Compliance Programs is the sole authority for determining compliance with Executive Order 11246 and 41 Code of Federal Regulation Chapter 60 and the Contractor should contact them regarding related compliance issues.

Source 41 CFR 60-4 Affirmative Action Requirements

Source: 41 CFR 60-4.2 Solicitations

NOTICE OF REQUIREMENT FOR AFFIRMATIVE ACTION TO ENSURE EQUAL EMPLOYMENT OPPORTUNITY (EXECUTIVE ORDER 11246)

The Offeror's or Bidder's attention is called to the "Equal Opportunity Clause" and the "Standard Federal Equal Employment Specifications" set forth herein.

The goals and timetables for minority and female participation, expressed in percentage terms for the Contractor's aggregate workforce in each trade on all construction work in the covered area, are as follows:

	Goals for minority participation for each trade	Goals for female participation in each trade
<u>STANDARD METROPOLITAN STATISTICAL AREAS (SMSA)</u>		
SALEM-PLAISTOW:	4.0	6.9
MANCHESTER-NASHUA	0.7	6.9
<u>NON-SMSA COUNTIES</u>		
COOS, GRAFTON, SULLIVAN:	0.8	6.9
BELKNAP, MERRIMACK, CARROLL, STRAFFORD:	3.6	6.9
CHESHIRE:	5.9	6.9
ROCKINGHAM:	4.0	6.9
HILLSBOROUGH:	0.7	6.9

These goals are applicable to all the Contractor's construction work (whether or not it is Federal or federally assisted) performed in the covered area. If the contractor performs construction work in a geographical area located outside of the covered area, it shall apply the goals established for such geographical area where the work is actually performed. With regard to this second area, the contractor also is subject to the goals for both its federally involved and nonfederally involved construction.

The Contractor's compliance with the Executive Order and the regulations in 41 CFR Part 60-4 shall be based on its implementation of the Equal Opportunity Clause, specific affirmative action obligations required by the specifications set forth in 41 CFR 60-4.3(a), and its efforts to meet the goals. The hours of minority and female employment and training must be substantially uniform throughout the length of the contract, and in each trade, and the contractor shall make a good faith effort to employ minorities and women evenly on each of its projects. The transfer of minority or female employees or trainees from Contractor to Contractor or from project to project for the sole purpose of meeting the Contractor's goals shall be a violation of the contract, the Executive Order and the regulations in 41 CFR Part 60-4. Compliance with the goals will be measured against the total work hours performed.

The Contractor shall provide written notification to the Director of the Office of Federal Contract Compliance Programs within 10 working days of award of any construction subcontract in excess of \$10,000 at any tier for construction work under the contract resulting from this solicitation addressed as follows:

Director
Federal Contract Compliance Program
US Department of Labor
JFK Building, Room 1612-C
Boston, MA 02203

The notification shall list the name, address and telephone number of the subcontractor; employer identification number of the subcontractor; estimated dollar amount of the subcontract; estimated starting and completion dates of the subcontract; and the geographical area in which the subcontract is to be performed **as noted within the Contract Special Provisions** for Affirmative Action to ensure Equal Employment Opportunity..

Source 41 CFR 60-4 Affirmative Action Requirements

Source 41 CFR 60-4.3 Equal Opportunity Clauses

Standard Federal Equal Employment Opportunity Construction Contract Specifications (Executive Order 11246)

[1]. As used in these specifications:

- a. "Covered area" means the geographical area described in the solicitation from which this contract resulted;
- b. "Director" means Director, Office of Federal Contract Compliance Programs, United States Department of Labor, or any person to whom the Director delegates authority;
- c. "Employer identification number" means the Federal Social Security number used on the Employer's Quarterly Federal Tax Return, U.S. Treasury Department Form 941.
- d. "Minority" includes:
 - (i) Black (all persons having origins in any of the Black African racial groups not of Hispanic origin);
 - (ii) Hispanic (all persons of Mexican, Puerto Rican, Cuban, Central or South American or other Spanish Culture or origin, regardless of race);
 - (iii) Asian and Pacific Islander (all persons having origins in any of the original peoples of the Far East, Southeast Asia, the Indian Subcontinent, or the Pacific Islands); and
 - (iv) American Indian or Alaskan Native (all persons having origins in any of the original peoples of North America and maintaining identifiable tribal affiliations through membership and participation or community identification).

[2]. Whenever the Contractor, or any Subcontractor at any tier, subcontracts a portion of the work involving any construction trade, it shall physically include in each subcontract in excess of \$10,000 the provisions of these specifications and the Notice which contains the applicable goals for minority and female participation and which is set forth in the solicitations from which this contract resulted.

[3]. If the Contractor is participating (pursuant to 41 CFR 60-4.5) in a Hometown Plan approved by the U.S. Department of Labor in the covered area either individually or through an association, its affirmative action obligations on all work in the Plan area (including goals and timetables) shall be in accordance with that Plan for those trades which have unions participating in the Plan. Contractors must be able to demonstrate their participation in and compliance with the provisions of any such Hometown Plan. Each Contractor or Subcontractor participating in an approved Plan is individually required to comply with its obligations under the EEO clause, and to make a good faith effort to achieve each goal under the Plan in each trade in which it has employees. The overall good faith performance by other Contractors or Subcontractors toward a goal in an approved Plan does not excuse any covered Contractor's or Subcontractor's failure to take good faith efforts to achieve the Plan goals and timetables.

[4]. The Contractor shall implement the specific affirmative action standards provided in paragraphs 7 a through p of these specifications. The goals set forth in the solicitation from which this contract resulted are expressed

as percentages of the total hours of employment and training of minority and female utilization the Contractor should reasonably be able to achieve in each construction trade in which it has employees in the covered area. Covered Construction contractors performing construction work in geographical areas where they do not have a Federal or federally assisted construction contract shall apply the minority and female goals established for the geographical area where the work is being performed. Goals are published periodically in the Federal Register in notice form, and such notices may be obtained from any Office of Federal Contract Compliance Programs office or from Federal procurement contracting officers. The Contractor is expected to make substantially uniform progress in meeting its goals in each craft during the period specified.

[5]. Neither the provisions of any collective bargaining agreement, nor the failure by a union with whom the Contractor has a collective bargaining agreement, to refer either minorities or women shall excuse the Contractor's obligations under these specifications, Executive Order 11246, or the regulations promulgated pursuant thereto.

[6]. In order for the nonworking training hours of apprentices and trainees to be counted in meeting the goals, such apprentices and trainees must be employed by the Contractor during the training period, and the Contractor must have made a commitment to employ the apprentices and trainees at the completion of their training, subject to the availability of employment opportunities. Trainees must be trained pursuant to training programs approved by the U.S. Department of Labor.

[7]. The Contractor shall take specific affirmative actions to ensure equal employment opportunity. The evaluation of the Contractor's compliance with these specifications shall be based upon its effort to achieve maximum results from its actions. The Contractor shall document these efforts fully, and shall implement affirmative action steps at least as extensive as the following:

- a. Ensure and maintain a working environment free of harassment, intimidation, and coercion at all sites, and in all facilities at which the Contractor's employees are assigned to work. The Contractor, where possible, will assign two or more women to each construction project. The Contractor shall specifically ensure that all foremen, superintendents, and other on-site supervisory personnel are aware of and carry out the Contractor's obligation to maintain such a working environment, with specific attention to minority or female individuals working at such sites or in such facilities.

- b. Establish and maintain a current list of minority and female recruitment sources, provide written notification to minority and female recruitment sources and to community organizations when the Contractor or its unions have

Source 41 CFR 60-4 Affirmative Action Requirements

employment opportunities available, and maintain a record of the organizations' responses.

c. Maintain a current file of the names, addresses and telephone numbers of each minority and female off-the-street applicant and minority or female referral from a union, a recruitment source or community organization and of what action was taken with respect to each such individual. If such individual was sent to the union hiring hall for referral and was not referred back to the Contractor by the union or, if referred, not employed by the Contractor, this shall be documented in the file with the reason therefore, along with whatever additional actions the Contractor may have taken.

d. Provide immediate written notification to the Director when the union or unions with which the Contractor has a collective bargaining agreement has not referred to the Contractor a minority person or woman sent by the Contractor, or when the Contractor has other information that the union referral process has impeded the Contractor's efforts to meet its obligations.

e. Develop on-the-job training opportunities and/or participate in training programs for the area which expressly include minorities and women, including upgrading programs and apprenticeship and trainee programs relevant to the Contractor's employment needs, especially those programs funded or approved by the Department of Labor. The Contractor shall provide notice of these programs to the sources compiled under 7b above.

f. Disseminate the Contractor's EEO policy by providing notice of the policy to unions and training programs and requesting their cooperation in assisting the Contractor in meeting its EEO obligations; by including it in any policy manual and collective bargaining agreement; by publicizing it in the company newspaper, annual report, etc.; by specific review of the policy with all management personnel and with all minority and female employees at least once a year; and by posting the company EEO policy on bulletin boards accessible to all employees at each location where construction work is performed.

g. Review, at least annually, the company's EEO policy and affirmative action obligations under these specifications with all employees having any responsibility for hiring, assignment, layoff, termination or other employment decisions including specific review of these items with onsite supervisory personnel such as Superintendents, General Foremen, etc., prior to the initiation of construction work at any job site. A written record shall be made and maintained identifying the time and place of these meetings, persons attending, subject matter discussed, and disposition of the subject matter.

h. Disseminate the Contractor's EEO policy externally by including it in any advertising in the news media, specifically including minority and female news media, and providing written notification to and discussing the Contractor's EEO policy with other Contractors and Subcontractors with whom the Contractor does or anticipates doing business.

i. Direct its recruitment efforts, both oral and written, to minority, female and community organizations, to schools with minority and female students and to minority and female recruitment and training organizations serving the Contractor's

recruitment area and employment needs. Not later than one month prior to the date for the acceptance of applications for apprenticeship or other training by any recruitment source, the Contractor shall send written notification to organizations such as the above, describing the openings, screening procedures, and tests to be used in the selection process.

j. Encourage present minority and female employees to recruit other minority persons and women and, where reasonable, provide after school, summer and vacation employment to minority and female youth both on the site and in other areas of a Contractor's work force.

k. Validate all tests and other selection requirements where there

l. Conduct, at least annually, an inventory and evaluation at least of all minority and female personnel for promotional opportunities and encourage these employees to seek or to prepare for, through appropriate training, etc., such opportunities.

m. Ensure that seniority practices, job classifications, work assignments and other personnel practices, do not have a discriminatory effect by continually monitoring all personnel and employment related activities to ensure that the EEO policy and the Contractor's obligations under these specifications are being carried out.

n. Ensure that all facilities and company activities are nonsegregated except that separate or single-user toilet and necessary changing facilities shall be provided to assure privacy between the sexes.

o. Document and maintain a record of all solicitations of offers for subcontracts from minority and female construction contractors and suppliers, including circulation of solicitations to minority and female contractor associations and other business associations.

p. Conduct a review, at least annually, of all supervisors' adherence to and performance under the Contractor's EEO policies and affirmative action obligations.

8. Contractors are encouraged to participate in voluntary associations which assist in fulfilling one or more of their affirmative action obligations (7a through p). The efforts of a contractor association, joint contractor-union, contractor-community, or other similar group of which the contractor is a member and participant, may be asserted as fulfilling any one or more of its obligations under 7a through p of these Specifications provided that the contractor actively participates in the group, makes every effort to assure that the group has a positive impact on the employment of minorities and women in the industry, ensures that the concrete benefits of the program are reflected in the Contractor's minority and female workforce participation, makes a good faith effort to meet its individual goals

and timetables, and can provide access to documentation which demonstrates the effectiveness of actions taken on behalf of the Contractor. The obligation to comply, however, is the Contractor's and failure of such a group to fulfill an obligation shall not be a defense for the Contractor's noncompliance.

9. A single goal for minorities and a separate single goal for women have been established. The Contractor, however, is required to provide equal employment opportunity and to take

Source 41 CFR 60-4 Affirmative Action Requirements

affirmative action for all minority groups, both male and female, and all women, both minority and non-minority. Consequently, the Contractor may be in violation of the Executive Order if a particular group is employed in a substantially disparate manner (for example, even though the Contractor has achieved its goals for women generally, the Contractor may be in violation of the Executive Order if a specific minority group of women is underutilized).

10. The Contractor shall not use the goals and timetables or affirmative action standards to discriminate against any person because of race, color, religion, sex, or national origin.

11. The Contractor shall not enter into any Subcontract with any person or firm debarred from Government contracts pursuant to Executive Order 11246.

12. The Contractor shall carry out such sanctions and penalties for violation of these specifications and of the Equal Opportunity Clause, including suspension, termination and cancellation of existing subcontracts as may be imposed or ordered pursuant to Executive Order 11246, as amended, and its implementing regulations, by the Office of Federal Contract Compliance Programs. Any Contractor who fails to carry out such sanctions and penalties shall be in violation of these specifications and Executive Order 11246, as amended.

13. The Contractor, in fulfilling its obligations under these specifications, shall implement specific affirmative action steps, at least as extensive as those standards prescribed in paragraph 7 of these specifications, so as to achieve maximum results from its efforts to ensure equal employment opportunity. If the Contractor fails to comply with the requirements of the Executive Order, the implementing regulations, or these specifications, the Director shall proceed in accordance with 41 CFR 60-4.8.

14. The Contractor shall designate a responsible official to monitor all employment related activity to ensure that the company EEO policy is being carried out, to submit reports relating to the provisions hereof as may be required by the Government and to keep records. Records shall at least include for each employee the name, address, telephone numbers, construction trade, union affiliation if any, employee identification number when assigned, social security number, race, sex, status (e.g., mechanic, apprentice trainee, helper, or laborer), dates of changes in status, hours worked per week in the indicated trade, rate of pay, and locations at which the work was performed. Records shall be maintained in an easily understandable and retrievable form; however, to the degree that existing records satisfy this requirement, contractors shall not be required to maintain separate records.

15. Nothing herein provided shall be construed as a limitation upon the application of other laws which establish different standards of compliance or upon the application of requirements for the hiring of local or other area residents (e.g., those under the Public Works Employment Act of 1977 and the Community Development Block Grant Program).

(b) The notice set forth in 41 CFR 60-4.2 and the specifications set forth in 41 CFR 60-4.3 replace the New Form for Federal Equal Employment Opportunity Bid Conditions for Federal and Federally Assisted Construction published at 41 FR 32482 and commonly known as the Model Federal EEO Bid Conditions, and the New Form shall not be used after the regulations in 41 CFR Part 60-4 become effective.

[43 FR 49254, Oct. 20, 1978; 43 FR 51401, Nov. 3, 1978, as amended at 45

FR 65978, Oct. 3, 1980]

**REQUIRED CONTRACT PROVISIONS
FEDERAL-AID CONSTRUCTION CONTRACTS**

- I. General
- II. Nondiscrimination
- III. Nonsegregated Facilities
- IV. Davis-Bacon and Related Act Provisions
- V. Contract Work Hours and Safety Standards Act Provisions
- VI. Subletting or Assigning the Contract
- VII. Safety: Accident Prevention
- VIII. False Statements Concerning Highway Projects
- IX. Implementation of Clean Air Act and Federal Water Pollution Control Act
- X. Compliance with Governmentwide Suspension and Debarment Requirements
- XI. Certification Regarding Use of Contract Funds for Lobbying

3. A breach of any of the stipulations contained in these Required Contract Provisions may be sufficient grounds for withholding of progress payments, withholding of final payment, termination of the contract, suspension / debarment or any other action determined to be appropriate by the contracting agency and FHWA.

4. Selection of Labor: During the performance of this contract, the contractor shall not use convict labor for any purpose within the limits of a construction project on a Federal-aid highway unless it is labor performed by convicts who are on parole, supervised release, or probation. The term Federal-aid highway does not include roadways functionally classified as local roads or rural minor collectors.

ATTACHMENTS

A. Employment and Materials Preference for Appalachian Development Highway System or Appalachian Local Access Road Contracts (included in Appalachian contracts only)

I. GENERAL

1. Form FHWA-1273 must be physically incorporated in each construction contract funded under Title 23 (excluding emergency contracts solely intended for debris removal). The contractor (or subcontractor) must insert this form in each subcontract and further require its inclusion in all lower tier subcontracts (excluding purchase orders, rental agreements and other agreements for supplies or services).

The applicable requirements of Form FHWA-1273 are incorporated by reference for work done under any purchase order, rental agreement or agreement for other services. The prime contractor shall be responsible for compliance by any subcontractor, lower-tier subcontractor or service provider.

Form FHWA-1273 must be included in all Federal-aid design-build contracts, in all subcontracts and in lower tier subcontracts (excluding subcontracts for design services, purchase orders, rental agreements and other agreements for supplies or services). The design-builder shall be responsible for compliance by any subcontractor, lower-tier subcontractor or service provider.

Contracting agencies may reference Form FHWA-1273 in bid proposal or request for proposal documents, however, the Form FHWA-1273 must be physically incorporated (not referenced) in all contracts, subcontracts and lower-tier subcontracts (excluding purchase orders, rental agreements and other agreements for supplies or services related to a construction contract).

2. Subject to the applicability criteria noted in the following sections, these contract provisions shall apply to all work performed on the contract by the contractor's own organization and with the assistance of workers under the contractor's immediate superintendence and to all work performed on the contract by piecework, station work, or by subcontract.

II. NONDISCRIMINATION

The provisions of this section related to 23 CFR Part 230 are applicable to all Federal-aid construction contracts and to all related construction subcontracts of \$10,000 or more. The provisions of 23 CFR Part 230 are not applicable to material supply, engineering, or architectural service contracts.

In addition, the contractor and all subcontractors must comply with the following policies: Executive Order 11246, 41 CFR 60, 29 CFR 1625-1627, Title 23 USC Section 140, the Rehabilitation Act of 1973, as amended (29 USC 794), Title VI of the Civil Rights Act of 1964, as amended, and related regulations including 49 CFR Parts 21, 26 and 27; and 23 CFR Parts 200, 230, and 633.

The contractor and all subcontractors must comply with: the requirements of the Equal Opportunity Clause in 41 CFR 60-1.4(b) and, for all construction contracts exceeding \$10,000, the Standard Federal Equal Employment Opportunity Construction Contract Specifications in 41 CFR 60-4.3.

Note: The U.S. Department of Labor has exclusive authority to determine compliance with Executive Order 11246 and the policies of the Secretary of Labor including 41 CFR 60, and 29 CFR 1625-1627. The contracting agency and the FHWA have the authority and the responsibility to ensure compliance with Title 23 USC Section 140, the Rehabilitation Act of 1973, as amended (29 USC 794), and Title VI of the Civil Rights Act of 1964, as amended, and related regulations including 49 CFR Parts 21, 26 and 27; and 23 CFR Parts 200, 230, and 633.

The following provision is adopted from 23 CFR 230, Appendix A, with appropriate revisions to conform to the U.S. Department of Labor (US DOL) and FHWA requirements.

1. Equal Employment Opportunity: Equal employment opportunity (EEO) requirements not to discriminate and to take affirmative action to assure equal opportunity as set forth under laws, executive orders, rules, regulations (28 CFR 35, 29 CFR 1630, 29 CFR 1625-1627, 41 CFR 60 and 49 CFR 27) and orders of the Secretary of Labor as modified by the provisions prescribed herein, and imposed pursuant to 23 U.S.C. 140 shall constitute the EEO and specific affirmative action standards for the contractor's project activities under

this contract. The provisions of the Americans with Disabilities Act of 1990 (42 U.S.C. 12101 et seq.) set forth under 28 CFR 35 and 29 CFR 1630 are incorporated by reference in this contract. In the execution of this contract, the contractor agrees to comply with the following minimum specific requirement activities of EEO:

a. The contractor will work with the contracting agency and the Federal Government to ensure that it has made every good faith effort to provide equal opportunity with respect to all of its terms and conditions of employment and in their review of activities under the contract.

b. The contractor will accept as its operating policy the following statement:

"It is the policy of this Company to assure that applicants are employed, and that employees are treated during employment, without regard to their race, religion, sex, color, national origin, age or disability. Such action shall include: employment, upgrading, demotion, or transfer; recruitment or recruitment advertising; layoff or termination; rates of pay or other forms of compensation; and selection for training, including apprenticeship, pre-apprenticeship, and/or on-the-job training."

2. EEO Officer: The contractor will designate and make known to the contracting officers an EEO Officer who will have the responsibility for and must be capable of effectively administering and promoting an active EEO program and who must be assigned adequate authority and responsibility to do so.

3. Dissemination of Policy: All members of the contractor's staff who are authorized to hire, supervise, promote, and discharge employees, or who recommend such action, or who are substantially involved in such action, will be made fully cognizant of, and will implement, the contractor's EEO policy and contractual responsibilities to provide EEO in each grade and classification of employment. To ensure that the above agreement will be met, the following actions will be taken as a minimum:

a. Periodic meetings of supervisory and personnel office employees will be conducted before the start of work and then not less often than once every six months, at which time the contractor's EEO policy and its implementation will be reviewed and explained. The meetings will be conducted by the EEO Officer.

b. All new supervisory or personnel office employees will be given a thorough indoctrination by the EEO Officer, covering all major aspects of the contractor's EEO obligations within thirty days following their reporting for duty with the contractor.

c. All personnel who are engaged in direct recruitment for the project will be instructed by the EEO Officer in the contractor's procedures for locating and hiring minorities and women.

d. Notices and posters setting forth the contractor's EEO policy will be placed in areas readily accessible to employees, applicants for employment and potential employees.

e. The contractor's EEO policy and the procedures to implement such policy will be brought to the attention of employees by means of meetings, employee handbooks, or other appropriate means.

4. Recruitment: When advertising for employees, the contractor will include in all advertisements for employees the notation: "An Equal Opportunity Employer." All such advertisements will be placed in publications having a large circulation among minorities and women in the area from which the project work force would normally be derived.

a. The contractor will, unless precluded by a valid bargaining agreement, conduct systematic and direct recruitment through public and private employee referral sources likely to yield qualified minorities and women. To meet this requirement, the contractor will identify sources of potential minority group employees, and establish with such identified sources procedures whereby minority and women applicants may be referred to the contractor for employment consideration.

b. In the event the contractor has a valid bargaining agreement providing for exclusive hiring hall referrals, the contractor is expected to observe the provisions of that agreement to the extent that the system meets the contractor's compliance with EEO contract provisions. Where implementation of such an agreement has the effect of discriminating against minorities or women, or obligates the contractor to do the same, such implementation violates Federal nondiscrimination provisions.

c. The contractor will encourage its present employees to refer minorities and women as applicants for employment. Information and procedures with regard to referring such applicants will be discussed with employees.

5. Personnel Actions: Wages, working conditions, and employee benefits shall be established and administered, and personnel actions of every type, including hiring, upgrading, promotion, transfer, demotion, layoff, and termination, shall be taken without regard to race, color, religion, sex, national origin, age or disability. The following procedures shall be followed:

a. The contractor will conduct periodic inspections of project sites to insure that working conditions and employee facilities do not indicate discriminatory treatment of project site personnel.

b. The contractor will periodically evaluate the spread of wages paid within each classification to determine any evidence of discriminatory wage practices.

c. The contractor will periodically review selected personnel actions in depth to determine whether there is evidence of discrimination. Where evidence is found, the contractor will promptly take corrective action. If the review indicates that the discrimination may extend beyond the actions reviewed, such corrective action shall include all affected persons.

d. The contractor will promptly investigate all complaints of alleged discrimination made to the contractor in connection with its obligations under this contract, will attempt to resolve such complaints, and will take appropriate corrective action within a reasonable time. If the investigation indicates that the discrimination may affect persons other than the complainant, such corrective action shall include such other persons. Upon completion of each investigation, the contractor will inform every complainant of all of their avenues of appeal.

6. Training and Promotion:

a. The contractor will assist in locating, qualifying, and increasing the skills of minorities and women who are

applicants for employment or current employees. Such efforts should be aimed at developing full journey level status employees in the type of trade or job classification involved.

b. Consistent with the contractor's work force requirements and as permissible under Federal and State regulations, the contractor shall make full use of training programs, i.e., apprenticeship, and on-the-job training programs for the geographical area of contract performance. In the event a special provision for training is provided under this contract, this subparagraph will be superseded as indicated in the special provision. The contracting agency may reserve training positions for persons who receive welfare assistance in accordance with 23 U.S.C. 140(a).

c. The contractor will advise employees and applicants for employment of available training programs and entrance requirements for each.

d. The contractor will periodically review the training and promotion potential of employees who are minorities and women and will encourage eligible employees to apply for such training and promotion.

7. Unions: If the contractor relies in whole or in part upon unions as a source of employees, the contractor will use good faith efforts to obtain the cooperation of such unions to increase opportunities for minorities and women. Actions by the contractor, either directly or through a contractor's association acting as agent, will include the procedures set forth below:

a. The contractor will use good faith efforts to develop, in cooperation with the unions, joint training programs aimed toward qualifying more minorities and women for membership in the unions and increasing the skills of minorities and women so that they may qualify for higher paying employment.

b. The contractor will use good faith efforts to incorporate an EEO clause into each union agreement to the end that such union will be contractually bound to refer applicants without regard to their race, color, religion, sex, national origin, age or disability.

c. The contractor is to obtain information as to the referral practices and policies of the labor union except that to the extent such information is within the exclusive possession of the labor union and such labor union refuses to furnish such information to the contractor, the contractor shall so certify to the contracting agency and shall set forth what efforts have been made to obtain such information.

d. In the event the union is unable to provide the contractor with a reasonable flow of referrals within the time limit set forth in the collective bargaining agreement, the contractor will, through independent recruitment efforts, fill the employment vacancies without regard to race, color, religion, sex, national origin, age or disability; making full efforts to obtain qualified and/or qualified minorities and women. The failure of a union to provide sufficient referrals (even though it is obligated to provide exclusive referrals under the terms of a collective bargaining agreement) does not relieve the contractor from the requirements of this paragraph. In the event the union referral practice prevents the contractor from meeting the obligations pursuant to Executive Order 11246, as amended, and these special provisions, such contractor shall immediately notify the contracting agency.

8. Reasonable Accommodation for Applicants / Employees with Disabilities: The contractor must be familiar

with the requirements for and comply with the Americans with Disabilities Act and all rules and regulations established there under. Employers must provide reasonable accommodation in all employment activities unless to do so would cause an undue hardship.

9. Selection of Subcontractors, Procurement of Materials and Leasing of Equipment: The contractor shall not discriminate on the grounds of race, color, religion, sex, national origin, age or disability in the selection and retention of subcontractors, including procurement of materials and leases of equipment. The contractor shall take all necessary and reasonable steps to ensure nondiscrimination in the administration of this contract.

a. The contractor shall notify all potential subcontractors and suppliers and lessors of their EEO obligations under this contract.

b. The contractor will use good faith efforts to ensure subcontractor compliance with their EEO obligations.

10. Assurance Required by 49 CFR 26.13(b):

a. The requirements of 49 CFR Part 26 and the State DOT's U.S. DOT-approved DBE program are incorporated by reference.

b. The contractor or subcontractor shall not discriminate on the basis of race, color, national origin, or sex in the performance of this contract. The contractor shall carry out applicable requirements of 49 CFR Part 26 in the award and administration of DOT-assisted contracts. Failure by the contractor to carry out these requirements is a material breach of this contract, which may result in the termination of this contract or such other remedy as the contracting agency deems appropriate.

11. Records and Reports: The contractor shall keep such records as necessary to document compliance with the EEO requirements. Such records shall be retained for a period of three years following the date of the final payment to the contractor for all contract work and shall be available at reasonable times and places for inspection by authorized representatives of the contracting agency and the FHWA.

a. The records kept by the contractor shall document the following:

(1) The number and work hours of minority and non-minority group members and women employed in each work classification on the project;

(2) The progress and efforts being made in cooperation with unions, when applicable, to increase employment opportunities for minorities and women; and

(3) The progress and efforts being made in locating, hiring, training, qualifying, and upgrading minorities and women;

b. The contractors and subcontractors will submit an annual report to the contracting agency each July for the duration of the project, indicating the number of minority, women, and non-minority group employees currently engaged in each work classification required by the contract work. This information is to be reported on Form FHWA-1391. The staffing data should represent the project work force on board in all or any part of the last payroll period preceding the end of July. If on-the-job training is being required by special provision, the contractor

will be required to collect and report training data. The employment data should reflect the work force on board during all or any part of the last payroll period preceding the end of July.

III. NONSEGREGATED FACILITIES

This provision is applicable to all Federal-aid construction contracts and to all related construction subcontracts of \$10,000 or more.

The contractor must ensure that facilities provided for employees are provided in such a manner that segregation on the basis of race, color, religion, sex, or national origin cannot result. The contractor may neither require such segregated use by written or oral policies nor tolerate such use by employee custom. The contractor's obligation extends further to ensure that its employees are not assigned to perform their services at any location, under the contractor's control, where the facilities are segregated. The term "facilities" includes waiting rooms, work areas, restaurants and other eating areas, time clocks, restrooms, washrooms, locker rooms, and other storage or dressing areas, parking lots, drinking fountains, recreation or entertainment areas, transportation, and housing provided for employees. The contractor shall provide separate or single-user restrooms and necessary dressing or sleeping areas to assure privacy between sexes.

IV. DAVIS-BACON AND RELATED ACT PROVISIONS

This section is applicable to all Federal-aid construction projects exceeding \$2,000 and to all related subcontracts and lower-tier subcontracts (regardless of subcontract size). The requirements apply to all projects located within the right-of-way of a roadway that is functionally classified as Federal-aid highway. This excludes roadways functionally classified as local roads or rural minor collectors, which are exempt. Contracting agencies may elect to apply these requirements to other projects.

The following provisions are from the U.S. Department of Labor regulations in 29 CFR 5.5 "Contract provisions and related matters" with minor revisions to conform to the FHWA-1273 format and FHWA program requirements.

1. Minimum wages

a. All laborers and mechanics employed or working upon the site of the work, will be paid unconditionally and not less often than once a week, and without subsequent deduction or rebate on any account (except such payroll deductions as are permitted by regulations issued by the Secretary of Labor under the Copeland Act (29 CFR part 3)), the full amount of wages and bona fide fringe benefits (or cash equivalents thereof) due at time of payment computed at rates not less than those contained in the wage determination of the Secretary of Labor which is attached hereto and made a part hereof, regardless of any contractual relationship which may be alleged to exist between the contractor and such laborers and mechanics.

Contributions made or costs reasonably anticipated for bona fide fringe benefits under section 1(b)(2) of the Davis-Bacon Act on behalf of laborers or mechanics are considered wages paid to such laborers or mechanics, subject to the provisions

of paragraph 1.d. of this section; also, regular contributions made or costs incurred for more than a weekly period (but not less often than quarterly) under plans, funds, or programs which cover the particular weekly period, are deemed to be constructively made or incurred during such weekly period. Such laborers and mechanics shall be paid the appropriate wage rate and fringe benefits on the wage determination for the classification of work actually performed, without regard to skill, except as provided in 29 CFR 5.5(a)(4). Laborers or mechanics performing work in more than one classification may be compensated at the rate specified for each classification for the time actually worked therein; Provided, That the employer's payroll records accurately set forth the time spent in each classification in which work is performed. The wage determination (including any additional classification and wage rates conformed under paragraph 1.b. of this section) and the Davis-Bacon poster (WH-1321) shall be posted at all times by the contractor and its subcontractors at the site of the work in a prominent and accessible place where it can be easily seen by the workers.

b.(1) The contracting officer shall require that any class of laborers or mechanics, including helpers, which is not listed in the wage determination and which is to be employed under the contract shall be classified in conformance with the wage determination. The contracting officer shall approve an additional classification and wage rate and fringe benefits therefore only when the following criteria have been met:

(i) The work to be performed by the classification requested is not performed by a classification in the wage determination; and

(ii) The classification is utilized in the area by the construction industry; and

(iii) The proposed wage rate, including any bona fide fringe benefits, bears a reasonable relationship to the wage rates contained in the wage determination.

(2) If the contractor and the laborers and mechanics to be employed in the classification (if known), or their representatives, and the contracting officer agree on the classification and wage rate (including the amount designated for fringe benefits where appropriate), a report of the action taken shall be sent by the contracting officer to the Administrator of the Wage and Hour Division, Employment Standards Administration, U.S. Department of Labor, Washington, DC 20210. The Administrator, or an authorized representative, will approve, modify, or disapprove every additional classification action within 30 days of receipt and so advise the contracting officer or will notify the contracting officer within the 30-day period that additional time is necessary.

(3) In the event the contractor, the laborers or mechanics to be employed in the classification or their representatives, and the contracting officer do not agree on the proposed classification and wage rate (including the amount designated for fringe benefits, where appropriate), the contracting officer shall refer the questions, including the views of all interested parties and the recommendation of the contracting officer, to the Wage and Hour Administrator for determination. The Wage and Hour Administrator, or an authorized representative, will issue a determination within 30 days of receipt and so advise the contracting officer or

will notify the contracting officer within the 30-day period that additional time is necessary.

(4) The wage rate (including fringe benefits where appropriate) determined pursuant to paragraphs 1.b.(2) or 1.b.(3) of this section, shall be paid to all workers performing work in the classification under this contract from the first day on which work is performed in the classification.

c. Whenever the minimum wage rate prescribed in the contract for a class of laborers or mechanics includes a fringe benefit which is not expressed as an hourly rate, the contractor shall either pay the benefit as stated in the wage determination or shall pay another bona fide fringe benefit or an hourly cash equivalent thereof.

d. If the contractor does not make payments to a trustee or other third person, the contractor may consider as part of the wages of any laborer or mechanic the amount of any costs reasonably anticipated in providing bona fide fringe benefits under a plan or program, Provided, That the Secretary of Labor has found, upon the written request of the contractor, that the applicable standards of the Davis-Bacon Act have been met. The Secretary of Labor may require the contractor to set aside in a separate account assets for the meeting of obligations under the plan or program.

2. Withholding

The contracting agency shall upon its own action or upon written request of an authorized representative of the Department of Labor, withhold or cause to be withheld from the contractor under this contract, or any other Federal contract with the same prime contractor, or any other federally-assisted contract subject to Davis-Bacon prevailing wage requirements, which is held by the same prime contractor, so much of the accrued payments or advances as may be considered necessary to pay laborers and mechanics, including apprentices, trainees, and helpers, employed by the contractor or any subcontractor the full amount of wages required by the contract. In the event of failure to pay any laborer or mechanic, including any apprentice, trainee, or helper, employed or working on the site of the work, all or part of the wages required by the contract, the contracting agency may, after written notice to the contractor, take such action as may be necessary to cause the suspension of any further payment, advance, or guarantee of funds until such violations have ceased.

3. Payrolls and basic records

a. Payrolls and basic records relating thereto shall be maintained by the contractor during the course of the work and preserved for a period of three years thereafter for all laborers and mechanics working at the site of the work. Such records shall contain the name, address, and social security number of each such worker, his or her correct classification, hourly rates of wages paid (including rates of contributions or costs anticipated for bona fide fringe benefits or cash equivalents thereof of the types described in section 1(b)(2)(B) of the Davis-Bacon Act), daily and weekly number of hours worked, deductions made and actual wages paid. Whenever the Secretary of Labor has found under 29 CFR 5.5(a)(1)(iv) that the wages of any laborer or mechanic include the amount of any costs reasonably anticipated in providing benefits under a plan or program described in section 1(b)(2)(B) of the Davis-

Bacon Act, the contractor shall maintain records which show that the commitment to provide such benefits is enforceable, that the plan or program is financially responsible, and that the plan or program has been communicated in writing to the laborers or mechanics affected, and records which show the costs anticipated or the actual cost incurred in providing such benefits. Contractors employing apprentices or trainees under approved programs shall maintain written evidence of the registration of apprenticeship programs and certification of trainee programs, the registration of the apprentices and trainees, and the ratios and wage rates prescribed in the applicable programs.

b.(1) The contractor shall submit weekly for each week in which any contract work is performed a copy of all payrolls to the contracting agency. The payrolls submitted shall set out accurately and completely all of the information required to be maintained under 29 CFR 5.5(a)(3)(i), except that full social security numbers and home addresses shall not be included on weekly transmittals. Instead the payrolls shall only need to include an individually identifying number for each employee (e.g., the last four digits of the employee's social security number). The required weekly payroll information may be submitted in any form desired. Optional Form WH-347 is available for this purpose from the Wage and Hour Division Web site at <http://www.dol.gov/esa/whd/forms/wh347instr.htm> or its successor site. The prime contractor is responsible for the submission of copies of payrolls by all subcontractors. Contractors and subcontractors shall maintain the full social security number and current address of each covered worker, and shall provide them upon request to the contracting agency for transmission to the State DOT, the FHWA or the Wage and Hour Division of the Department of Labor for purposes of an investigation or audit of compliance with prevailing wage requirements. It is not a violation of this section for a prime contractor to require a subcontractor to provide addresses and social security numbers to the prime contractor for its own records, without weekly submission to the contracting agency..

(2) Each payroll submitted shall be accompanied by a "Statement of Compliance," signed by the contractor or subcontractor or his or her agent who pays or supervises the payment of the persons employed under the contract and shall certify the following:

(i) That the payroll for the payroll period contains the information required to be provided under §5.5 (a)(3)(ii) of Regulations, 29 CFR part 5, the appropriate information is being maintained under §5.5 (a)(3)(i) of Regulations, 29 CFR part 5, and that such information is correct and complete;

(ii) That each laborer or mechanic (including each helper, apprentice, and trainee) employed on the contract during the payroll period has been paid the full weekly wages earned, without rebate, either directly or indirectly, and that no deductions have been made either directly or indirectly from the full wages earned, other than permissible deductions as set forth in Regulations, 29 CFR part 3;

(iii) That each laborer or mechanic has been paid not less than the applicable wage rates and fringe benefits or cash equivalents for the classification of work performed, as specified in the applicable wage determination incorporated into the contract.

(3) The weekly submission of a properly executed certification set forth on the reverse side of Optional Form WH-347 shall satisfy the requirement for submission of the "Statement of Compliance" required by paragraph 3.b.(2) of this section.

(4) The falsification of any of the above certifications may subject the contractor or subcontractor to civil or criminal prosecution under section 1001 of title 18 and section 231 of title 31 of the United States Code.

c. The contractor or subcontractor shall make the records required under paragraph 3.a. of this section available for inspection, copying, or transcription by authorized representatives of the contracting agency, the State DOT, the FHWA, or the Department of Labor, and shall permit such representatives to interview employees during working hours on the job. If the contractor or subcontractor fails to submit the required records or to make them available, the FHWA may, after written notice to the contractor, the contracting agency or the State DOT, take such action as may be necessary to cause the suspension of any further payment, advance, or guarantee of funds. Furthermore, failure to submit the required records upon request or to make such records available may be grounds for debarment action pursuant to 29 CFR 5.12.

4. Apprentices and trainees

a. Apprentices (programs of the USDOL).

Apprentices will be permitted to work at less than the predetermined rate for the work they performed when they are employed pursuant to and individually registered in a bona fide apprenticeship program registered with the U.S. Department of Labor, Employment and Training Administration, Office of Apprenticeship Training, Employer and Labor Services, or with a State Apprenticeship Agency recognized by the Office, or if a person is employed in his or her first 90 days of probationary employment as an apprentice in such an apprenticeship program, who is not individually registered in the program, but who has been certified by the Office of Apprenticeship Training, Employer and Labor Services or a State Apprenticeship Agency (where appropriate) to be eligible for probationary employment as an apprentice.

The allowable ratio of apprentices to journeymen on the job site in any craft classification shall not be greater than the ratio permitted to the contractor as to the entire work force under the registered program. Any worker listed on a payroll at an apprentice wage rate, who is not registered or otherwise employed as stated above, shall be paid not less than the applicable wage rate on the wage determination for the classification of work actually performed. In addition, any apprentice performing work on the job site in excess of the ratio permitted under the registered program shall be paid not less than the applicable wage rate on the wage determination for the work actually performed. Where a contractor is performing construction on a project in a locality other than that in which its program is registered, the ratios and wage rates (expressed in percentages of the journeyman's hourly rate) specified in the contractor's or subcontractor's registered program shall be observed.

Every apprentice must be paid at not less than the rate specified in the registered program for the apprentice's level of progress, expressed as a percentage of the journeymen hourly

rate specified in the applicable wage determination. Apprentices shall be paid fringe benefits in accordance with the provisions of the apprenticeship program. If the apprenticeship program does not specify fringe benefits, apprentices must be paid the full amount of fringe benefits listed on the wage determination for the applicable classification. If the Administrator determines that a different practice prevails for the applicable apprentice classification, fringes shall be paid in accordance with that determination.

In the event the Office of Apprenticeship Training, Employer and Labor Services, or a State Apprenticeship Agency recognized by the Office, withdraws approval of an apprenticeship program, the contractor will no longer be permitted to utilize apprentices at less than the applicable predetermined rate for the work performed until an acceptable program is approved.

b. Trainees (programs of the USDOL).

Except as provided in 29 CFR 5.16, trainees will not be permitted to work at less than the predetermined rate for the work performed unless they are employed pursuant to and individually registered in a program which has received prior approval, evidenced by formal certification by the U.S. Department of Labor, Employment and Training Administration.

The ratio of trainees to journeymen on the job site shall not be greater than permitted under the plan approved by the Employment and Training Administration.

Every trainee must be paid at not less than the rate specified in the approved program for the trainee's level of progress, expressed as a percentage of the journeyman hourly rate specified in the applicable wage determination. Trainees shall be paid fringe benefits in accordance with the provisions of the trainee program. If the trainee program does not mention fringe benefits, trainees shall be paid the full amount of fringe benefits listed on the wage determination unless the Administrator of the Wage and Hour Division determines that there is an apprenticeship program associated with the corresponding journeyman wage rate on the wage determination which provides for less than full fringe benefits for apprentices. Any employee listed on the payroll at a trainee rate who is not registered and participating in a training plan approved by the Employment and Training Administration shall be paid not less than the applicable wage rate on the wage determination for the classification of work actually performed. In addition, any trainee performing work on the job site in excess of the ratio permitted under the registered program shall be paid not less than the applicable wage rate on the wage determination for the work actually performed.

In the event the Employment and Training Administration withdraws approval of a training program, the contractor will no longer be permitted to utilize trainees at less than the applicable predetermined rate for the work performed until an acceptable program is approved.

c. Equal employment opportunity. The utilization of apprentices, trainees and journeymen under this part shall be in conformity with the equal employment opportunity requirements of Executive Order 11246, as amended, and 29 CFR part 30.

d. Apprentices and Trainees (programs of the U.S. DOT).

Apprentices and trainees working under apprenticeship and skill training programs which have been certified by the Secretary of Transportation as promoting EEO in connection with Federal-aid highway construction programs are not subject to the requirements of paragraph 4 of this Section IV. The straight time hourly wage rates for apprentices and trainees under such programs will be established by the particular programs. The ratio of apprentices and trainees to journeymen shall not be greater than permitted by the terms of the particular program.

5. Compliance with Copeland Act requirements. The contractor shall comply with the requirements of 29 CFR part 3, which are incorporated by reference in this contract.

6. Subcontracts. The contractor or subcontractor shall insert Form FHWA-1273 in any subcontracts and also require the subcontractors to include Form FHWA-1273 in any lower tier subcontracts. The prime contractor shall be responsible for the compliance by any subcontractor or lower tier subcontractor with all the contract clauses in 29 CFR 5.5.

7. Contract termination: debarment. A breach of the contract clauses in 29 CFR 5.5 may be grounds for termination of the contract, and for debarment as a contractor and a subcontractor as provided in 29 CFR 5.12.

8. Compliance with Davis-Bacon and Related Act requirements. All rulings and interpretations of the Davis-Bacon and Related Acts contained in 29 CFR parts 1, 3, and 5 are herein incorporated by reference in this contract.

9. Disputes concerning labor standards. Disputes arising out of the labor standards provisions of this contract shall not be subject to the general disputes clause of this contract. Such disputes shall be resolved in accordance with the procedures of the Department of Labor set forth in 29 CFR parts 5, 6, and 7. Disputes within the meaning of this clause include disputes between the contractor (or any of its subcontractors) and the contracting agency, the U.S. Department of Labor, or the employees or their representatives.

10. Certification of eligibility.

a. By entering into this contract, the contractor certifies that neither it (nor he or she) nor any person or firm who has an interest in the contractor's firm is a person or firm ineligible to be awarded Government contracts by virtue of section 3(a) of the Davis-Bacon Act or 29 CFR 5.12(a)(1).

b. No part of this contract shall be subcontracted to any person or firm ineligible for award of a Government contract by virtue of section 3(a) of the Davis-Bacon Act or 29 CFR 5.12(a)(1).

c. The penalty for making false statements is prescribed in the U.S. Criminal Code, 18 U.S.C. 1001.

V. CONTRACT WORK HOURS AND SAFETY STANDARDS ACT

The following clauses apply to any Federal-aid construction contract in an amount in excess of \$100,000 and subject to the overtime provisions of the Contract Work Hours and Safety Standards Act. These clauses shall be inserted in addition to the clauses required by 29 CFR 5.5(a) or 29 CFR 4.6. As used in this paragraph, the terms laborers and mechanics include watchmen and guards.

1. Overtime requirements. No contractor or subcontractor contracting for any part of the contract work which may require or involve the employment of laborers or mechanics shall require or permit any such laborer or mechanic in any workweek in which he or she is employed on such work to work in excess of forty hours in such workweek unless such laborer or mechanic receives compensation at a rate not less than one and one-half times the basic rate of pay for all hours worked in excess of forty hours in such workweek.

2. Violation; liability for unpaid wages; liquidated damages. In the event of any violation of the clause set forth in paragraph (1.) of this section, the contractor and any subcontractor responsible therefor shall be liable for the unpaid wages. In addition, such contractor and subcontractor shall be liable to the United States (in the case of work done under contract for the District of Columbia or a territory, to such District or to such territory), for liquidated damages. Such liquidated damages shall be computed with respect to each individual laborer or mechanic, including watchmen and guards, employed in violation of the clause set forth in paragraph (1.) of this section, in the sum of \$10 for each calendar day on which such individual was required or permitted to work in excess of the standard workweek of forty hours without payment of the overtime wages required by the clause set forth in paragraph (1.) of this section.

3. Withholding for unpaid wages and liquidated damages. The FHWA or the contacting agency shall upon its own action or upon written request of an authorized representative of the Department of Labor withhold or cause to be withheld, from any moneys payable on account of work performed by the contractor or subcontractor under any such contract or any other Federal contract with the same prime contractor, or any other federally-assisted contract subject to the Contract Work Hours and Safety Standards Act, which is held by the same prime contractor, such sums as may be determined to be necessary to satisfy any liabilities of such contractor or subcontractor for unpaid wages and liquidated damages as provided in the clause set forth in paragraph (2.) of this section.

4. Subcontracts. The contractor or subcontractor shall insert in any subcontracts the clauses set forth in paragraph (1.) through (4.) of this section and also a clause requiring the subcontractors to include these clauses in any lower tier subcontracts. The prime contractor shall be responsible for compliance by any subcontractor or lower tier subcontractor with the clauses set forth in paragraphs (1.) through (4.) of this section.

VI. SUBLETTING OR ASSIGNING THE CONTRACT

This provision is applicable to all Federal-aid construction contracts on the National Highway System.

1. The contractor shall perform with its own organization contract work amounting to not less than 30 percent (or a greater percentage if specified elsewhere in the contract) of the total original contract price, excluding any specialty items designated by the contracting agency. Specialty items may be performed by subcontract and the amount of any such specialty items performed may be deducted from the total original contract price before computing the amount of work required to be performed by the contractor's own organization (23 CFR 635.116).

a. The term "perform work with its own organization" refers to workers employed or leased by the prime contractor, and equipment owned or rented by the prime contractor, with or without operators. Such term does not include employees or equipment of a subcontractor or lower tier subcontractor, agents of the prime contractor, or any other assignees. The term may include payments for the costs of hiring leased employees from an employee leasing firm meeting all relevant Federal and State regulatory requirements. Leased employees may only be included in this term if the prime contractor meets all of the following conditions:

(1) the prime contractor maintains control over the supervision of the day-to-day activities of the leased employees;

(2) the prime contractor remains responsible for the quality of the work of the leased employees;

(3) the prime contractor retains all power to accept or exclude individual employees from work on the project; and

(4) the prime contractor remains ultimately responsible for the payment of predetermined minimum wages, the submission of payrolls, statements of compliance and all other Federal regulatory requirements.

b. "Specialty Items" shall be construed to be limited to work that requires highly specialized knowledge, abilities, or equipment not ordinarily available in the type of contracting organizations qualified and expected to bid or propose on the contract as a whole and in general are to be limited to minor components of the overall contract.

2. The contract amount upon which the requirements set forth in paragraph (1) of Section VI is computed includes the cost of material and manufactured products which are to be purchased or produced by the contractor under the contract provisions.

3. The contractor shall furnish (a) a competent superintendent or supervisor who is employed by the firm, has full authority to direct performance of the work in accordance with the contract requirements, and is in charge of all construction operations (regardless of who performs the work) and (b) such other of its own organizational resources (supervision, management, and engineering services) as the contracting officer determines is necessary to assure the performance of the contract.

4. No portion of the contract shall be sublet, assigned or otherwise disposed of except with the written consent of the contracting officer, or authorized representative, and such consent when given shall not be construed to relieve the contractor of any responsibility for the fulfillment of the contract. Written consent will be given only after the contracting agency has assured that each subcontract is

evidenced in writing and that it contains all pertinent provisions and requirements of the prime contract.

5. The 30% self-performance requirement of paragraph (1) is not applicable to design-build contracts; however, contracting agencies may establish their own self-performance requirements.

VII. SAFETY: ACCIDENT PREVENTION

This provision is applicable to all Federal-aid construction contracts and to all related subcontracts.

1. In the performance of this contract the contractor shall comply with all applicable Federal, State, and local laws governing safety, health, and sanitation (23 CFR 635). The contractor shall provide all safeguards, safety devices and protective equipment and take any other needed actions as it determines, or as the contracting officer may determine, to be reasonably necessary to protect the life and health of employees on the job and the safety of the public and to protect property in connection with the performance of the work covered by the contract.

2. It is a condition of this contract, and shall be made a condition of each subcontract, which the contractor enters into pursuant to this contract, that the contractor and any subcontractor shall not permit any employee, in performance of the contract, to work in surroundings or under conditions which are unsanitary, hazardous or dangerous to his/her health or safety, as determined under construction safety and health standards (29 CFR 1926) promulgated by the Secretary of Labor, in accordance with Section 107 of the Contract Work Hours and Safety Standards Act (40 U.S.C. 3704).

3. Pursuant to 29 CFR 1926.3, it is a condition of this contract that the Secretary of Labor or authorized representative thereof, shall have right of entry to any site of contract performance to inspect or investigate the matter of compliance with the construction safety and health standards and to carry out the duties of the Secretary under Section 107 of the Contract Work Hours and Safety Standards Act (40 U.S.C.3704).

VIII. FALSE STATEMENTS CONCERNING HIGHWAY PROJECTS

This provision is applicable to all Federal-aid construction contracts and to all related subcontracts.

In order to assure high quality and durable construction in conformity with approved plans and specifications and a high degree of reliability on statements and representations made by engineers, contractors, suppliers, and workers on Federal-aid highway projects, it is essential that all persons concerned with the project perform their functions as carefully, thoroughly, and honestly as possible. Willful falsification, distortion, or misrepresentation with respect to any facts related to the project is a violation of Federal law. To prevent any misunderstanding regarding the seriousness of these and similar acts, Form FHWA-1022 shall be posted on each Federal-aid highway project (23 CFR 635) in one or more places where it is readily available to all persons concerned with the project:

18 U.S.C. 1020 reads as follows:

"Whoever, being an officer, agent, or employee of the United States, or of any State or Territory, or whoever, whether a person, association, firm, or corporation, knowingly makes any false statement, false representation, or false report as to the character, quality, quantity, or cost of the material used or to be used, or the quantity or quality of the work performed or to be performed, or the cost thereof in connection with the submission of plans, maps, specifications, contracts, or costs of construction on any highway or related project submitted for approval to the Secretary of Transportation; or

Whoever knowingly makes any false statement, false representation, false report or false claim with respect to the character, quality, quantity, or cost of any work performed or to be performed, or materials furnished or to be furnished, in connection with the construction of any highway or related project approved by the Secretary of Transportation; or

Whoever knowingly makes any false statement or false representation as to material fact in any statement, certificate, or report submitted pursuant to provisions of the Federal-aid Roads Act approved July 1, 1916, (39 Stat. 355), as amended and supplemented;

Shall be fined under this title or imprisoned not more than 5 years or both."

IX. IMPLEMENTATION OF CLEAN AIR ACT AND FEDERAL WATER POLLUTION CONTROL ACT

This provision is applicable to all Federal-aid construction contracts and to all related subcontracts.

By submission of this bid/proposal or the execution of this contract, or subcontract, as appropriate, the bidder, proposer, Federal-aid construction contractor, or subcontractor, as appropriate, will be deemed to have stipulated as follows:

1. That any person who is or will be utilized in the performance of this contract is not prohibited from receiving an award due to a violation of Section 508 of the Clean Water Act or Section 306 of the Clean Air Act.

2. That the contractor agrees to include or cause to be included the requirements of paragraph (1) of this Section X in every subcontract, and further agrees to take such action as the contracting agency may direct as a means of enforcing such requirements.

X. CERTIFICATION REGARDING DEBARMENT, SUSPENSION, INELIGIBILITY AND VOLUNTARY EXCLUSION

This provision is applicable to all Federal-aid construction contracts, design-build contracts, subcontracts, lower-tier subcontracts, purchase orders, lease agreements, consultant contracts or any other covered transaction requiring FHWA approval or that is estimated to cost \$25,000 or more – as defined in 2 CFR Parts 180 and 1200.

1. Instructions for Certification – First Tier Participants:

a. By signing and submitting this proposal, the prospective first tier participant is providing the certification set out below.

b. The inability of a person to provide the certification set out below will not necessarily result in denial of participation in this

covered transaction. The prospective first tier participant shall submit an explanation of why it cannot provide the certification set out below. The certification or explanation will be considered in connection with the department or agency's determination whether to enter into this transaction. However, failure of the prospective first tier participant to furnish a certification or an explanation shall disqualify such a person from participation in this transaction.

c. The certification in this clause is a material representation of fact upon which reliance was placed when the contracting agency determined to enter into this transaction. If it is later determined that the prospective participant knowingly rendered an erroneous certification, in addition to other remedies available to the Federal Government, the contracting agency may terminate this transaction for cause of default.

d. The prospective first tier participant shall provide immediate written notice to the contracting agency to whom this proposal is submitted if any time the prospective first tier participant learns that its certification was erroneous when submitted or has become erroneous by reason of changed circumstances.

e. The terms "covered transaction," "debarred," "suspended," "ineligible," "participant," "person," "principal," and "voluntarily excluded," as used in this clause, are defined in 2 CFR Parts 180 and 1200. "First Tier Covered Transactions" refers to any covered transaction between a grantee or subgrantee of Federal funds and a participant (such as the prime or general contract). "Lower Tier Covered Transactions" refers to any covered transaction under a First Tier Covered Transaction (such as subcontracts). "First Tier Participant" refers to the participant who has entered into a covered transaction with a grantee or subgrantee of Federal funds (such as the prime or general contractor). "Lower Tier Participant" refers any participant who has entered into a covered transaction with a First Tier Participant or other Lower Tier Participants (such as subcontractors and suppliers).

f. The prospective first tier participant agrees by submitting this proposal that, should the proposed covered transaction be entered into, it shall not knowingly enter into any lower tier covered transaction with a person who is debarred, suspended, declared ineligible, or voluntarily excluded from participation in this covered transaction, unless authorized by the department or agency entering into this transaction.

g. The prospective first tier participant further agrees by submitting this proposal that it will include the clause titled "Certification Regarding Debarment, Suspension, Ineligibility and Voluntary Exclusion-Lower Tier Covered Transactions," provided by the department or contracting agency, entering into this covered transaction, without modification, in all lower tier covered transactions and in all solicitations for lower tier covered transactions exceeding the \$25,000 threshold.

h. A participant in a covered transaction may rely upon a certification of a prospective participant in a lower tier covered transaction that is not debarred, suspended, ineligible, or voluntarily excluded from the covered transaction, unless it knows that the certification is erroneous. A participant is responsible for ensuring that its principals are not suspended, debarred, or otherwise ineligible to participate in covered transactions. To verify the eligibility of its principals, as well as the eligibility of any lower tier prospective participants, each participant may, but is not required to, check the Excluded Parties List System website (<https://www.epls.gov/>), which is compiled by the General Services Administration.

i. Nothing contained in the foregoing shall be construed to require the establishment of a system of records in order to render in good faith the certification required by this clause. The knowledge and information of the prospective participant is not required to exceed that which is normally possessed by a prudent person in the ordinary course of business dealings.

j. Except for transactions authorized under paragraph (f) of these instructions, if a participant in a covered transaction knowingly enters into a lower tier covered transaction with a person who is suspended, debarred, ineligible, or voluntarily excluded from participation in this transaction, in addition to other remedies available to the Federal Government, the department or agency may terminate this transaction for cause or default.

* * * * *

2. Certification Regarding Debarment, Suspension, Ineligibility and Voluntary Exclusion – First Tier Participants:

a. The prospective first tier participant certifies to the best of its knowledge and belief, that it and its principals:

(1) Are not presently debarred, suspended, proposed for debarment, declared ineligible, or voluntarily excluded from participating in covered transactions by any Federal department or agency;

(2) Have not within a three-year period preceding this proposal been convicted of or had a civil judgment rendered against them for commission of fraud or a criminal offense in connection with obtaining, attempting to obtain, or performing a public (Federal, State or local) transaction or contract under a public transaction; violation of Federal or State antitrust statutes or commission of embezzlement, theft, forgery, bribery, falsification or destruction of records, making false statements, or receiving stolen property;

(3) Are not presently indicted for or otherwise criminally or civilly charged by a governmental entity (Federal, State or local) with commission of any of the offenses enumerated in paragraph (a)(2) of this certification; and

(4) Have not within a three-year period preceding this application/proposal had one or more public transactions (Federal, State or local) terminated for cause or default.

b. Where the prospective participant is unable to certify to any of the statements in this certification, such prospective participant shall attach an explanation to this proposal.

2. Instructions for Certification - Lower Tier Participants:

(Applicable to all subcontracts, purchase orders and other lower tier transactions requiring prior FHWA approval or estimated to cost \$25,000 or more - 2 CFR Parts 180 and 1200)

a. By signing and submitting this proposal, the prospective lower tier is providing the certification set out below.

b. The certification in this clause is a material representation of fact upon which reliance was placed when this transaction was entered into. If it is later determined that the prospective lower tier participant knowingly rendered an erroneous certification, in addition to other remedies available to the Federal Government, the department, or agency with which

this transaction originated may pursue available remedies, including suspension and/or debarment.

c. The prospective lower tier participant shall provide immediate written notice to the person to which this proposal is submitted if at any time the prospective lower tier participant learns that its certification was erroneous by reason of changed circumstances.

d. The terms "covered transaction," "debarred," "suspended," "ineligible," "participant," "person," "principal," and "voluntarily excluded," as used in this clause, are defined in 2 CFR Parts 180 and 1200. You may contact the person to which this proposal is submitted for assistance in obtaining a copy of those regulations. "First Tier Covered Transactions" refers to any covered transaction between a grantee or subgrantee of Federal funds and a participant (such as the prime or general contract). "Lower Tier Covered Transactions" refers to any covered transaction under a First Tier Covered Transaction (such as subcontracts). "First Tier Participant" refers to the participant who has entered into a covered transaction with a grantee or subgrantee of Federal funds (such as the prime or general contractor). "Lower Tier Participant" refers any participant who has entered into a covered transaction with a First Tier Participant or other Lower Tier Participants (such as subcontractors and suppliers).

e. The prospective lower tier participant agrees by submitting this proposal that, should the proposed covered transaction be entered into, it shall not knowingly enter into any lower tier covered transaction with a person who is debarred, suspended, declared ineligible, or voluntarily excluded from participation in this covered transaction, unless authorized by the department or agency with which this transaction originated.

f. The prospective lower tier participant further agrees by submitting this proposal that it will include this clause titled "Certification Regarding Debarment, Suspension, Ineligibility and Voluntary Exclusion-Lower Tier Covered Transaction," without modification, in all lower tier covered transactions and in all solicitations for lower tier covered transactions exceeding the \$25,000 threshold.

g. A participant in a covered transaction may rely upon a certification of a prospective participant in a lower tier covered transaction that is not debarred, suspended, ineligible, or voluntarily excluded from the covered transaction, unless it knows that the certification is erroneous. A participant is responsible for ensuring that its principals are not suspended, debarred, or otherwise ineligible to participate in covered transactions. To verify the eligibility of its principals, as well as the eligibility of any lower tier prospective participants, each participant may, but is not required to, check the Excluded Parties List System website (<https://www.epls.gov/>), which is compiled by the General Services Administration.

h. Nothing contained in the foregoing shall be construed to require establishment of a system of records in order to render in good faith the certification required by this clause. The knowledge and information of participant is not required to exceed that which is normally possessed by a prudent person in the ordinary course of business dealings.

i. Except for transactions authorized under paragraph e of these instructions, if a participant in a covered transaction knowingly enters into a lower tier covered transaction with a person who is suspended, debarred, ineligible, or voluntarily excluded from participation in this transaction, in addition to other remedies available to the Federal Government, the

department or agency with which this transaction originated may pursue available remedies, including suspension and/or debarment.

* * * * *

Certification Regarding Debarment, Suspension, Ineligibility and Voluntary Exclusion--Lower Tier Participants:

1. The prospective lower tier participant certifies, by submission of this proposal, that neither it nor its principals is presently debarred, suspended, proposed for debarment, declared ineligible, or voluntarily excluded from participating in covered transactions by any Federal department or agency.

2. Where the prospective lower tier participant is unable to certify to any of the statements in this certification, such prospective participant shall attach an explanation to this proposal.

* * * * *

XI. CERTIFICATION REGARDING USE OF CONTRACT FUNDS FOR LOBBYING

This provision is applicable to all Federal-aid construction contracts and to all related subcontracts which exceed \$100,000 (49 CFR 20).

1. The prospective participant certifies, by signing and submitting this bid or proposal, to the best of his or her knowledge and belief, that:

a. No Federal appropriated funds have been paid or will be paid, by or on behalf of the undersigned, to any person for influencing or attempting to influence an officer or employee of any Federal agency, a Member of Congress, an officer or employee of Congress, or an employee of a Member of Congress in connection with the awarding of any Federal contract, the making of any Federal grant, the making of any Federal loan, the entering into of any cooperative agreement, and the extension, continuation, renewal, amendment, or modification of any Federal contract, grant, loan, or cooperative agreement.

b. If any funds other than Federal appropriated funds have been paid or will be paid to any person for influencing or attempting to influence an officer or employee of any Federal agency, a Member of Congress, an officer or employee of Congress, or an employee of a Member of Congress in connection with this Federal contract, grant, loan, or cooperative agreement, the undersigned shall complete and submit Standard Form-LLL, "Disclosure Form to Report Lobbying," in accordance with its instructions.

2. This certification is a material representation of fact upon which reliance was placed when this transaction was made or entered into. Submission of this certification is a prerequisite for making or entering into this transaction imposed by 31 U.S.C. 1352. Any person who fails to file the required certification shall be subject to a civil penalty of not less than \$10,000 and not more than \$100,000 for each such failure.

3. The prospective participant also agrees by submitting its bid or proposal that the participant shall require that the language of this certification be included in all lower tier subcontracts, which exceed \$100,000 and that all such recipients shall certify and disclose accordingly.

**ATTACHMENT A - EMPLOYMENT AND MATERIALS
PREFERENCE FOR APPALACHIAN DEVELOPMENT
HIGHWAY SYSTEM OR APPALACHIAN LOCAL ACCESS
ROAD CONTRACTS**

This provision is applicable to all Federal-aid projects funded under the Appalachian Regional Development Act of 1965.

1. During the performance of this contract, the contractor undertaking to do work which is, or reasonably may be, done as on-site work, shall give preference to qualified persons who regularly reside in the labor area as designated by the DOL wherein the contract work is situated, or the subregion, or the Appalachian counties of the State wherein the contract work is situated, except:

a. To the extent that qualified persons regularly residing in the area are not available.

b. For the reasonable needs of the contractor to employ supervisory or specially experienced personnel necessary to assure an efficient execution of the contract work.

c. For the obligation of the contractor to offer employment to present or former employees as the result of a lawful collective bargaining contract, provided that the number of nonresident persons employed under this subparagraph (1c) shall not exceed 20 percent of the total number of employees employed by the contractor on the contract work, except as provided in subparagraph (4) below.

2. The contractor shall place a job order with the State Employment Service indicating (a) the classifications of the laborers, mechanics and other employees required to perform the contract work, (b) the number of employees required in each classification, (c) the date on which the participant estimates such employees will be required, and (d) any other pertinent information required by the State Employment Service to complete the job order form. The job order may be placed with the State Employment Service in writing or by telephone. If during the course of the contract work, the information submitted by the contractor in the original job order is substantially modified, the participant shall promptly notify the State Employment Service.

3. The contractor shall give full consideration to all qualified job applicants referred to him by the State Employment Service. The contractor is not required to grant employment to any job applicants who, in his opinion, are not qualified to perform the classification of work required.

4. If, within one week following the placing of a job order by the contractor with the State Employment Service, the State Employment Service is unable to refer any qualified job applicants to the contractor, or less than the number requested, the State Employment Service will forward a certificate to the contractor indicating the unavailability of applicants. Such certificate shall be made a part of the contractor's permanent project records. Upon receipt of this certificate, the contractor may employ persons who do not normally reside in the labor area to fill positions covered by the certificate, notwithstanding the provisions of subparagraph (1c) above.

5. The provisions of 23 CFR 633.207(e) allow the contracting agency to provide a contractual preference for the use of mineral resource materials native to the Appalachian region.

6. The contractor shall include the provisions of Sections 1 through 4 of this Attachment A in every subcontract for work which is, or reasonably may be, done as on-site work.

DISCLOSURE OF LOBBYING ACTIVITIES

Complete this form to disclose lobbying activities pursuant to 31 U.S.C. 1352
(See Reverse for public burden disclosure.)

1. Type of Federal Action: <input type="checkbox"/> a. contract <input type="checkbox"/> b. grant <input type="checkbox"/> c. cooperative agreement <input type="checkbox"/> d. loan <input type="checkbox"/> e. loan guarantee <input type="checkbox"/> f. loan insurance	2. Status of Federal Action: <input type="checkbox"/> a. bid/offer/application <input type="checkbox"/> b. initial award <input type="checkbox"/> c. post-award	3. Report Type: <input type="checkbox"/> a. initial filing <input type="checkbox"/> b. material change For Material Change Only: year _____ quarter _____ date of last report _____
4. Name and Address of Reporting Entity: <input type="checkbox"/> Prime <input type="checkbox"/> Subawardee Tier _____, if known: Congressional District, if known:		5. If Reporting Entity in No. 4 is a Subawardee, Enter Name and Address of Prime: Congressional District, if known:
6. Federal Department/Agency:	7. Federal Program Name/Description: CFDA Number, if applicable:	
8. Federal Action Number, if known:	9. Award Amount, if known: <div style="text-align: center;">\$ _____</div>	
10. a. Name and Address of Lobbying Registrant <i>(If individual, last name, first name, MI):</i>	b. Individuals Performing Services <i>(Including address if different from No. 10a)</i> <i>(last name, first name, MI):</i>	
11. Information requested through this form is authorized by title 31 U.S.C. section 1352. This disclosure of lobbying activities is a material representation of fact upon which reliance was placed by the tier above when this transaction was made or entered into. This disclosure is required pursuant to 31 U.S.C. 1352. This information will be reported to the Congress semi-annually and will be available for public inspection. Any person who fails to file the required disclosure shall be subject to a civil penalty of not less that \$10,000 and not more than \$100,000 for each such failure.	Signature: _____ Print Name: _____ Title: _____ Telephone No.: _____ Date: _____	
Federal Use Only:		Authorized for Local Reproduction Standard Form LLL (Rev. 7-97)

INSTRUCTIONS FOR COMPLETION OF SF-LLL, DISCLOSURE OF LOBBYING ACTIVITIES

This disclosure form shall be completed by the reporting entity, whether subawardee or prime Federal recipient, at the initiation or receipt of a covered Federal action, or a material change to a previous filing pursuant to title 31 U.S.C. section 1352. The filing of a form is required for each payment or agreement to make payment to any lobbying entity for influencing or attempting to influence an officer or employee of any agency, a Member of Congress, an officer or employee of Congress, or an employee of a Member of Congress in connection with a covered Federal action. Complete all items that apply for both the initial filing and material change report. Refer to the implementing guidance published by the Office of Management and Budget for additional information.

1. Identify the type of covered Federal action for which lobbying activity is and/or has been secured to influence the outcome of a covered Federal action.
2. Identify the status of the covered Federal action.
3. Identify the appropriate classification of this report. If this a followup report caused by a material change to the information previously reported, enter the year and quarter in which the change occurred, Enter the date of the last previously submitted report by this reporting entity for this covered Federal action.
4. Enter the full name, address, city, State and zip code of the reporting entity. Include Congressional District, if known. Check the appropriate classification of the reporting entity that designates if it is, or expects to be a prime or subaward receipt. Identify the tier of the subawardee, e.g., the first subawardee of the prime is the 1st tier. Subawards include but are not limited to subcontracts, subgrants and contract awards under grants.
5. If the organization filing the report in item 4 checks "Subawardee," then enter the full name, address, city, State and zip code of the prime Federal recipient. Include Congressional District, if known.
6. Enter the name of the Federal agency making the award or loan commitment. Include at least one organizational level below agency name, if known. For example, Department of Transportation, United States Coast Guard.
7. Enter the Federal program name or description for the covered Federal action (Item 1). If known, enter the full Catalog of Federal Domestic Assistance (CFDA) number for grants, cooperative agreements, loans and loan commitments.
8. Enter the most appropriate Federal identifying number available for the Federal action identified in Item 1 (e.g., Request for Proposal (RFP) number; Invitation for bid (IFB) number; grant announcement number; the contract, grant, or loan award number; the application/proposal control number assigned by the Federal agency). Include prefixes, e.g. "RFP-DE-90-001."
9. For a covered Federal action where there has been an award or loan commitment by the Federal agency, enter the Federal amount of the award/loan commitment for the prime entity identified in Item 4 or 5.
10. (a) Enter the full name, address, city, State and zip code of the lobbying registrant under the Lobbying Disclosure Act of 1995 engaged by the reporting entity identified in Item 4 to influence the covered Federal action.

(b) Enter the full names of the individual(s) performing services, and include full address if different from 10 (a). Enter Last Name, First Name and Middle Initial (MI).
11. Certifying official shall sign and date the form, print his/her name, title and telephone number.

According to the Paperwork Reduction Act, as amended, no persons are required to respond to a collection of information unless it displays a valid OMB Control Number. The valid OMB control number for this information collection is OMB No. 0348-0046. Public reporting burden for this collection of information is estimated to average 10 minutes per response, including time for reviewing instructions, searching existing data sources, gathering and maintaining the data needed, and completing and reviewing the collection of information. Send comments regarding the burden estimate or any other aspect of this collection of information, including suggestions for reducing this burden, to the Office of Management and Budget, Paperwork Reduction Project (0348-0046), Washington, DC 20503.

04/01/09

SA

SSD: 06/28/04

ALL FA PROJECTS

SPECIAL ATTENTION

DISADVANTAGED BUSINESS ENTERPRISE (DBE) DIRECTORY

The current New Hampshire Unified Disadvantaged Business Enterprise (DBE) Directory is available on the NHDOT website at <http://www.nh.gov/dot/business/contractors.htm>. If you have questions or do not have access to the Internet, the directory may be obtained from DBE Coordinator, located at 7 Hazen Drive, Concord, NH 03302, Tel: (603) 271-6612.

SPECIAL ATTENTION

Disadvantaged Business Enterprise (DBE)

Disadvantaged Business Enterprise (DBE) Policy. It shall be the policy of the New Hampshire Department of Transportation (NHDOT) to ensure nondiscriminatory opportunity for Disadvantaged Business Enterprises (DBE's) to participate in the performance of all contracts and subcontracts financed with Federal funds as specified by the regulations of the United States Department of Transportation (USDOT), Federal Highway Administration and as set forth below.

1. Policy. It is the policy of the United States Department of Transportation to ensure nondiscriminatory opportunity for disadvantaged business enterprises, as defined in 49 Code of Federal Regulation (CFR) Part 26, to participate in the performance of contracts and subcontracts financed in whole or in part with Federal funds. Consequently, the DBE requirements of 49 CFR Part 26 applies to this contract.

2. Disadvantaged Business Enterprise (DBE) Obligation. The State and its Contractor agree to ensure nondiscriminatory opportunity for disadvantaged business enterprises, as defined in 49 CFR Part 26, to participate in the performance of contracts and subcontracts financed in whole or in part with Federal funds. **Prime Contractors and subcontractors who further sublet must include this assurance in every subcontract:** *The Contractor, sub recipient or subcontractor shall not discriminate on the basis of race, color, national origin, or sex in the award and performance of this contract. The Contractor shall carry out applicable requirements of 49 CFR Part 26 in the award and administration of USDOT-assisted contracts. Failure by any contractor to carry out these requirements is a material breach of this contract, which may result in the termination of this Contract or such other remedy, as the NHDOT deems appropriate.*

3. Sanctions of Non-Compliance. The Contractor is hereby advised that failure of the Contractor, or any Subcontractor performing work under this Contract, to carry out the requirements set forth in paragraphs 1 and 2 above shall constitute a breach of contract and, after notification of the United States Department of Transportation, may result in termination of this Contract or such remedy as the State deems appropriate.

Overall Statewide DBE Goals. The NHDOT currently employs a race/gender neutral DBE policy to attain its overall statewide DBE goals. This means that unless otherwise stated in the Contract, the NHDOT relies on the voluntary cooperation of all contractors to utilize DBE's on every project, sufficient to meet or exceed the current statewide DBE goal. Although the majority of statewide DBE goals are currently voluntary, failure of the NHDOT to meet or exceed the overall statewide DBE goal as required by the Federal Highway Administration (FHWA), could necessitate placement of mandatory DBE participation requirements on all future statewide projects.

Disadvantaged Business Enterprise (DBE) Program Goals. The New Hampshire Department of Transportation is required to set an overall DBE goal for participation in all transportation related Federal-aid projects. The goal is determined following guidelines set forth in 49 CFR 26.45, and based on the availability of ready, willing and able DBE's who submitted bids for transportation related projects, compared as a percentage of all available contractors who submitted bids for transportation related projects during the same time period. The DBE goal may be adjusted to take into account other factors impacting DBE utilization, in an effort to narrowly tailor the overall DBE goal. The detailed goal setting methodology and current overall DBE goal may be viewed on the NHDOT website at www.nh.gov/dot.

7/29/2013

Page 2 of 4

Disadvantaged Business Enterprise (DBE) Definition. A DBE is defined as a business that is owned and controlled by one or more socially and economically disadvantaged person(s). For the purpose of this definition:

- A. "Socially and economically disadvantaged person" means an individual who is a citizen or lawful permanent resident of the United States and who is a Woman, Black, Hispanic, Portuguese, Native American, Asian American, or a member of another group, or an individual found to be disadvantaged by an individual determination of social disadvantage as described in 49 CFR 26 appendix E, determinations of social and economic disadvantage.
- B. "Owned and controlled" means a business which is:
- (1) A sole proprietorship legitimately owned and controlled by an individual who is a disadvantaged person.
 - (2) A partnership, joint venture or limited liability Company in which at least 51% of the beneficial ownership interests is legitimately held by a disadvantaged person(s).
 - (3) A corporation or other entity in which at least 51% of the voting interest and 51% of the beneficial ownership interests are legitimately held by a disadvantaged person(s).

The disadvantaged group owner(s) or stockholder(s) must possess control over management, interest in capital, and interest in earnings commensurate with the percentage of ownership. Disadvantaged participation in a joint venture must also be based on the sharing of real economic interest and must include proportionate control over management, capital, and earnings, as above. If the disadvantaged group ownership interests are real, substantial and continuing and not created solely to meet the requirements of this program, a firm is considered a bona fide DBE.

Certified DBE Directory. The current New Hampshire Unified Disadvantaged Business Enterprise (DBE) Directory is available online at www.nh.gov/dot. This directory contains all currently certified DBE's available for work in New Hampshire, and is updated monthly. Only firm's listed in this directory are eligible for DBE credit on NH Federal-aid projects. If you have questions about DBE certification, or do not have access to the Internet, please call the DBE Coordinator at (603) 271-6612 for assistance.

Counting DBE Participation For Project Goals. In order for payments made to DBE contractors to be counted toward DBE goals, the DBE contractors must perform a commercially useful function (CUF). The DBE must be responsible for execution of the work of the contract and must carry out its responsibilities by actually performing, managing, and supervising the work involved, consistent with standard industry practices. This means that:

- A. The DBE must also be responsible for ordering its own materials and supplies, determining quantity and quality, negotiating price, installing (where applicable) and paying for the material itself;
- B. The DBE must perform work commensurate with the amount of its contract;
- C. The DBE's contribution cannot be that of an extra participant or a conduit through which funds are passed in order to obtain the appearance of DBE participation;
- D. The DBE must exercise responsibility for at least fifty percent of the total cost of its contract with its own work force;
- E. None of the DBE's work can be subcontracted back to the Prime Contractor, nor can the DBE employ the prime's, or other subcontractor's supervisors currently working on the project;
- F. The DBE's labor force must be separate and apart from that of the Prime Contractor or other subcontractors on the project. Transferring crews between primes, subcontractors, and DBE contractors is not acceptable;

7/29/2013

Page 3 of 4

- G. The DBE owner must hold a Public Works license and any other professional or craft licenses required for the type of work he/she performs on the project;
- H. The DBE may rent or lease, at competitive rates, equipment needed on the project from customary leasing sources or from other subcontractors on the project.

Allowable credit for payments made to DBEs for work performed. A contractor may take credit for payments made to a certified DBE that satisfies (CUF) requirements at the following rate.

- A. A DBE Prime Contractor; count 100% of the value of work performed by own forces, equipment and materials count towards DBE goals.
- B. An approved DBE subcontractor; count 100% of the value of work performed by the DBE's own forces, equipment and materials, excluding the following:
 - The cost of materials/supplies purchased from a non-DBE Prime Contractor.
 - The value of work provided by non-DBE lower tier subcontractors, including non-DBE trucking to deliver asphalt to a DBE contractor.
- C. A DBE owner-operator of construction equipment; count 100% of expenditures committed.
- D. A DBE manufacturer; count 100% of expenditures committed. The manufacturer must be a firm that operates or maintains a factory or establishment that produces on the premises the materials or supplies obtained by the Prime Contractor.
- E. A regular DBE dealer/supplier; count 60% of expenditures committed.
A regular dealer/supplier is defined as a firm that owns, operates, or maintains a store, warehouse or other establishment, in which the materials or supplies required for the performance of the contract are bought, kept in stock, and regularly sold or leased to the public in the usual course of business. A person may be a dealer in such bulk items as petroleum products, steel, cement, gravel, stone or asphalt without owning, operating or maintaining a place of business, if the person both owns and operates distribution equipment for the products, by the means of a long term agreement, and not by a contract by contract basis.
- F. A DBE Broker; count for DBE credit only the fees or commissions charged for assistance in the procurement, and, fees and transportation charges for the delivery of materials or supplies required at the job site, but not the cost of materials procured. A broker is defined as any person(s) or firm who arranges or expedites transactions for materials or supplies, and does not take physical possession of the materials or supplies at their place of business for resale.
- G. A DBE renter of construction equipment to a contractor; count 20% of expenditures committed, with or without operator.
- H. A bona fide DBE service provider; count 100% of reasonable fees or commissions.
Eligible services include professional, technical, consultant, or managerial, services and assistance in the procurement of essential personnel, facilities, equipment, materials or supplies required for the performance of the contract. Eligible services also include agencies providing bonding and insurance specifically required for the performance of the contract.
- I. A trucking, hauling or delivery operation, count 100% of payments when trucks are owned, operated, licensed and insured by the DBE and used on the contract and, if applicable, includes the cost of the materials and supplies. 100% of payments when the DBE leases trucks from another DBE firm including an owner-operator. 100% of reasonable fees, or commissions, the DBE receives as a result of a lease arrangement for trucks from a non-DBE, including an owner-operator.
- J. Any combination of the above.

Reporting Requirements for Payments Made To DBE's: On all Federal-aid projects, the Prime Contractor is required to report payments made to DBE's during the life of the contract, on a quarterly basis, for the periods covering January 1st-March 31st, April 1st-June 30th, July 1st-September 30th and October 1st-December 31st, The NHDOT will provide the Prime Contractor with a quarterly DBE

7/29/2013

Page 4 of 4

payments report, detailing all DBE's subcontracted by the Prime Contractor, per project. The Prime Contractor shall report any payments made to DBE's during the requested reporting period. This documentation shall be submitted to the Office of Federal Compliance within the time period stated on the NHDOT quarterly request. Failure of the Prime Contractor to submit this information may result in the Department withholding progress payments.

Removal of Approved DBE From Transportation Related Project: Contractors may not terminate for convenience, any approved DBE subcontractor and perform the work with their own forces, without prior written consent from the NHDOT.

MUNICIPAL PROJECTS ONLY: Timely submission of invoices to Municipalities: Prime Contractors must submit all invoices received for satisfactorily completed work, from any subcontractor/lower-tier subcontractor/material supplier, to Municipalities for payment within 30 days of receipt.

ALL FA PROJECTS (STEEL & IRON PRODUCTS)

SPECIAL ATTENTION

BUY AMERICA

In accordance with the **BUY AMERICA** requirements of the Federal regulations, all manufacturing processes for steel and iron materials furnished for permanent incorporation into the work on this project shall occur in the United States. The only exception to this requirement is the production of pig iron and the processing, pelletizing and reduction of iron ore, which may occur in another country. Other than these exceptions, all melting, rolling, extruding, machining, bending, grinding, drilling, coating, etc. must occur in the United States.

Products of steel include, but are not limited to, such products as structural steel, piles, reinforcing steel, structural plate, steel culverts, guardrail and steel supports for signs, signals and luminaires. Products of iron include, but are not limited to, such products as cast iron frames and grates. Coatings include, but are not limited to, the applications of epoxy, galvanizing and paint. The coating material is not subject to this clause, only the application process.

A Certificate of Compliance, conforming to the requirements of Section 106.04, shall be furnished for steel and iron materials. Records to be maintained by the contractor for this certification shall include a signed mill test report and a signed certification by each supplier, distributor, fabricator, and manufacturer that has handled the steel or iron product affirming that every process, including the application of a coating, performed on the steel or iron product has been carried out in the United States of America, except as allowed by this Special Attention. The lack of these certifications will be justification for rejection of the steel or iron product.

The requirements of said law and regulations do not prevent a minimal use of foreign steel and iron materials if the cost of such materials used does not exceed one-tenth of one percent (0.1%) of the total contract price or \$2,500.00, whichever is greater.

Upon completion of the project, the Contractor shall certify in writing as to compliance with this Special Attention and also provide the total project delivered cost of all foreign steel and/or iron permanently incorporated into the project. The form for this certification is entitled "Buy America Certificate of Compliance" and can be found at www.NHDOT.com.

December 24, 1998
Supersedes Spec. Attn. dated 3/29/88 & 12/5/90

FHWA Projects

SPECIAL ATTENTION

**CONTRACT AFFIDAVIT - CERTIFICATION REGARDING DEBARMENT
SUSPENSION**

The separate form entitled, CONTRACT AFFIDAVIT (As Required by Section 112(c) of Title 23 USC) has been deleted from this proposal.

Bidders are advised that the last page of the bidding proposal has been revised to include the same reference, **IN BOLD PRINT**, relative to the non-collusion statement included on the discontinued form.

X X X X X X X X X X X X X X

The Contractor is advised that 49 CFR 29.510, Appendix A, requires that the Contractor, including all principals, certify that they are not currently under debarment or suspension or have not been under debarment or suspension within the past three years. (For certification instructions see next page).

The certification has been added, **IN BOLD PRINT**, onto the next to the last page of the bidding proposal.

The Contractor is further advised that Appendix B of 49 CFR 29.510 regarding certification of lower tier transactions has been added to Form FHWA-1273.

Appendix A - Certification regarding Debarment, Suspension, and other Responsibility Matters - Primary Covered Transactions.

Instruction for Certification

1. By signing and submitting this proposal, the prospective primary participant is providing the certification set out below.
2. The inability of a person to provide the certification required below will not necessarily result in denial of participation in this covered transaction. The prospective participant shall submit an explanation of why it cannot provide the certification set out below. The certification or explanation will be considered in connection with the department or agency's determination whether to enter into this transaction. However, failure of the prospective primary participant to furnish a certification or an explanation shall disqualify such person from participation in this transaction.
3. The certification in this clause is a material representation of fact upon which reliance was placed when the department or agency determined to enter into this transaction. If it is later determined that the prospective primary participant knowingly rendered an erroneous certification, in addition to other remedies available to the Federal Government, the department or agency may terminate this transaction for cause of default.
4. The prospective primary participant shall provide immediate written notice to the department or agency to whom this proposal is submitted if at any time the prospective primary participant learns that its certification was erroneous when submitted or has become erroneous by reason of changed circumstances.
5. The terms "covered transaction," "debarred," "suspended," "ineligible," "lower tier covered transaction," "participant," "person," "primary covered transaction," "principal," "proposal," and "voluntarily excluded," as used in this clause, have the meanings set out in the Definitions and Coverage sections of the rules implementing Executive Order 12549. You may contact the department or agency to which this proposal is being submitted for assistance in obtaining a copy of these regulations.
6. The prospective primary participant agrees by submitting this proposal that, should the proposed covered transaction be entered into, it shall not knowingly enter into any lower tier covered transaction with a person who is debarred, suspended, declared ineligible, or voluntarily excluded from participation in this covered transaction, unless authorized by the department or agency entering into this transaction.
7. The prospective primary participant further agrees by submitting this proposal that it will include the clause titled "Certification" Regarding Debarment, Suspension, Ineligibility and Voluntary Exclusion-Lower Tier Covered Transaction," provided by the department or agency entering into this covered transaction, without modification, in all lower tier covered transactions and in all solicitations for lower tier covered transactions.
8. A participant in a covered transaction may rely upon a certification of a prospective participant in a lower tier covered transaction that is not debarred, suspended, ineligible, or voluntarily excluded from the covered transaction, unless it knows that the certification is erroneous. A participant may decide the method and frequency by which it determines the eligibility of its principals. Each participant may, but is not required to, check the Nonprocurement List.
9. Nothing contained in the foregoing shall be construed to require establishment of a system of records in order to render in good faith the certification required by this clause. The knowledge and information of a participant is not required to exceed that which is normally possessed by a prudent person in the ordinary course of business dealings.
10. Except for transactions authorized under paragraph 6 of these instructions, if a participant in a covered transaction knowingly enters into a lower tier covered transaction with a person who is suspended, debarred, ineligible, or voluntarily excluded from participation in this transaction, in addition to other remedies available to the Federal Government, the department or agency may terminate this transaction for cause or default.

1/2001
Supersedes 3/90
ALL FA PROJECTS

SPECIAL ATTENTION

LOBBYING

UNITED STATES DEPARTMENT OF TRANSPORTATION FEDERAL HIGHWAY ADMINISTRATION

SUBJECT: LIMITATION ON USE OF GRANT OR CONTRACT FUNDS FOR LOBBYING

The lobbying restrictions were established by Section 319 of Public Law 101-121 (Department of the Interior and Related Agencies Appropriations Act for Fiscal Year 1990).

The law prohibits Federal funds from being expended by the recipient or any lower tier subrecipients of a Federal contract, grant, loan, or cooperative agreement to pay any person for influencing or attempting to influence a Federal agency or Congress in connection with the awarding of any Federal contract, the making of any Federal grant or loan, or the entering into of any cooperative agreement. The extension, continuation, renewal, amendment or modification of any Federal contract, grant, loan, or cooperative agreement is also covered.

Federal-aid contractors, and consultants, as well as lower tier subcontractors and subconsultants are also subject to the lobbying prohibition. To assure compliance, a certification provision is included in all Federal-aid construction solicitations and contracts, and consultant agreements exceeding \$100,000 in Federal funds.

The Contractor shall be aware that by signing and submitting this proposal, he or she is attesting to the requirements of the certification provisions.

During the period of performance of a grant or contract, recipients and subrecipients must file disclosure form (Standard Form LLL) at the end of each calendar year quarter in which there occurs any event that requires disclosure or that materially affects the accuracy of the information contained in any previously filed disclosure form.

Lower tier certifications should be maintained by the next tier above (i.e., prime contractors will keep the subcontractors' certification on file, etc.). Copies of Standard Form LLL will be included in the subcontract package for distribution to successful bidders.

SPECIAL ATTENTION

SUMMARY OF REQUIREMENTS FOR FEDERAL-AID PROJECTS

1. Subletting On Federal-aid Contracts.

- a. On Federal-Aid projects, the following documents are required to be incorporated in and made a part of every subcontract agreement (including lower-tier subcontract agreements):
 - NHDOT Policy on Subcontracting
 - Required Contract Provisions (FHWA-1273)
 - Disadvantaged Business Enterprise (DBE) Program Requirements (Standard Spec 103.06)
 - *41 CFR 60-4 Affirmative Action Requirements
 - **U.S. Department of Labor (USDOL) wage rates entitled "GENERAL WAGE DECISION" (as contained in the contract)

*Applicable only to contracts or subcontracts in excess of \$10,000
**Does not apply to companies performing non-Davis Bacon type work (testing, monitoring, and inspection services).
- b. Subcontractor Approvals for Companies Who Perform Testing, Monitoring, Inspection Services
 - 1) Companies and/or independent contractors performing testing, monitoring, or inspection, such as ground penetrating radar, erosion control monitoring, video inspection, SWPPP, environmental testing/monitoring or vibration monitoring, for example, require subcontractor approval (NHDOT must verify Workers Compensation (WC) Insurance coverage).
 - 2) The following subcontractor approval documentation is required:
 - OFC Form 15 (15a for a State managed project and 15b for Local Public Agency (LPA) projects), Transmittal
 - OFC Form 26, Work Certificate
 - Proof of Workers Compensation Insurance coverage (if not already on file)
- c. Contractors will not be approved/authorized to work until the Department's Annual Assurances requirements have been fulfilled.
- d. RSA 228:4-b shall apply to any work done by an individual contractor on any state transportation project.
- e. Prime Contractors shall submit consent to sublet packages to the NHDOT at least 5 working days prior to said subcontractor (or lower-tier subcontractor)

performing work on site. On LPA projects, the Prime Contractor shall also provide a courtesy copy to the town or the town's consultant, if applicable.

- f. LPA Projects Only: NHDOT Office of Federal Compliance (OFC) is the sole approval authority for all LPA construction projects. Consents to sublet shall be submitted directly to the OFC.

2. **FHWA Form 1273, Required Contract Provisions.**

- a. The Prime Contractor shall insert in each subcontract all the stipulations contained in the Required Contract Provisions. Primes shall further require their inclusion in any lower-tier subcontract or purchase order that may in-turn be made. The Required Contract Provisions shall not be incorporated by reference in any case.
 - b. In accordance with Section I, Paragraph 1, the Prime Contractor shall be responsible for compliance by any subcontractor, lower-tier subcontractor or service provider. This shall include any unpaid wages found to be owed that is not paid by a subcontractor or lower-tier subcontractor.
 - c. In accordance with Section I, Paragraph 3, "A breach of any of the stipulations contained in these Required Contract Provisions may be sufficient grounds for withholding of progress payments, withholding of final payment, termination of the contract, suspension/debarment or any other action determined to be appropriate by the contracting agency and FHWA."
3. **Submission of Payrolls**: Payrolls, as required by FHWA Form 1273, shall be submitted electronically (email) as a pdf document to the NHDOT Contract Administrator, named in the following format: Contractor's name (abbreviated is acceptable) followed by the "week ending" date (year/month/day). The Contractor's and each Sub-contractor's payroll shall be submitted as separate, individual files. Example: PrimeContr – 2014-12-03; SubcontraA – 2014-12-03; SubcontraB – 2014-12-03.
4. **Sign-In Sheets**. Use of daily sign-in sheets is **mandatory** on all LPA projects. Every worker must sign in, on a daily basis, prior to performing work on site. The OFC Form 20 shall be used for this purpose. The Prime Contractor is responsible to ensure sign-in sheet requirements are met and are turned in to the Contract Administrator on a daily basis. Contract Administrators shall review and initial sign-in sheets daily cross matching what employees have indicated for their work classification and what employers are indicating on certified payroll reports, and verifying employers of workers signing in have been approved to work by the NHDOT. Sign-in sheets shall be co-located with certified payrolls and filed in a 3-ring binder, newest sign-in sheets on top. Sign-in sheets are an inspection item. Note: Use of sign-in sheets may also be directed by the OFC on State managed projects for any contractor who does not accurately report all workers performing work on site on their payrolls.

5. **Requesting Work Classifications, Classifying Workers, and/or Payment of Wages.**

- a. The Prime Contractor is required to submit an additional request to the NHDOT for any classification of labor/equipment that they or their subcontractors shall be utilizing under the contract that is not contained in the proposal's Federal General Decision.
- b. Unless otherwise instructed by the OFC, a SF 1444 shall be used for this purpose.
- c. Requests must be submitted to the NHDOT prior to any work being performed in the classification(s).
- d. Contractors who do not receive a USDOL conformance decision from the OFC within 45 days of submission should follow-up with the OFC.
- e. Once a decision is received from the USDOL, the OFC will, in-turn, notify the Prime Contractor. In cases when the USDOL stipulates a higher rate of pay than the one proposed by a contractor, and the Contractor elects not to submit an appeal, restitution, if due, shall be paid to employees within 10 calendar days of being notified by the OFC. Restitution requirements of the NHDOT shall apply.
- f. Appeals shall be filed with the USDOL within 30 calendar days and a courtesy copy forwarded to the OFC at the same time. Restitution, if applicable, does not need to be paid during the time the appeal is under review by the USDOL.
- g. Contractors shall immediately inform the OFC whenever appeal decisions (including reconsideration requests) are received from the USDOL.
- h. In those cases when a contractor indicates to the OFC he/she plans to appeal the USDOL decision but fails to provide the OFC proof of submission within 30 calendar days, the contractor shall comply with the original USDOL decision. The OFC will subsequently notify the Contractor that proof of an appeal was not received within 30 days and restitution, if applicable, must be paid to workers within 10 calendar days. Contractors who fail to provide restitution will be deemed "in non-compliance."
- i. Time Sheets: Every contractor shall create and maintain time sheets for every worker performing work on the project. This includes salaried employees who perform work in a classification, either intermittingly or full time. Time sheets shall record all work performed during the work week, both Federal and non-Federal, shop time, travel time considered work time, including any time considered "hours worked" as described under the Fair Labor Standards Act, Part 785. When requested, Contractors shall provide copies of time sheets to the OFC in support of certified payroll report information being provided. Time sheets, payroll records, and other basic records relating thereto shall be maintained by the contractor during the course of the work and preserved for a period of three years thereafter for all laborers and mechanics working at the site of work.

- j. OFC payment release authorization letters (Ok to Pay letters) cannot be accomplished until all wage conformances have been deemed closed (USDOL responses have been received and there are no pending contractor wage appeals).
- k. Job Classifications Descriptions (Laboring Category): While most of skilled and unskilled crafts appearing in Wage Determinations are self-explanatory, the below classifications (not all inclusive) have been described by the NHDOT and are consistent with USDOL requirements. Workers performing in these classes, according to the description, will be classified by contractors accordingly:
 - 1) Asbestos Abatement: All work associated with asbestos abatement shall be classified as "Laborer," unless said work involves piping that will be reinsulated. In these cases, "Asbestos Abatement Worker" shall be used.
 - 2) Blaster: Supervises and assists in locating, loading, and firing blast holes with explosives to break up hard materials. This work includes any of the following duties on-site: determining the spacing and depth of drilled holes; determining the amount of explosives, timing and placement of detonators; handling blasting materials in the work area; loading holes with detonators, primers and explosives; tamping and stemming holes; directing the placement of blasting mats or other flyrock controls; and detonating the charges.
 - 3) Brick Mason (also called Brick Layers): Builds and repairs walls, floors, paths/sidewalks, partitions, fireplaces, chimneys, and other structures with brick, pavers, precast masonry panels, concrete block, and other masonry materials, with or without mortar.
 - 4) Drill Operator: Unless a hand held tool, which can then be classified and performed as a Common/General Laborer, all drill work shall be performed in the "Drill Operator" classification. Conformances, if needed, shall be consistent with this requirement.
 - 5) Guardrail Installer: Except for the "pounder," each person performing guardrail installation work shall be classified as "Guardrail Installer."
 - 6) Ironworker (Reinforcing): Positions and secures steel bars to placement of reinforced concrete; determines number, size, shape and location of reinforcing rods from plans, specifications, sketches and/or oral instructions; places and ties reinforcing steel using wire and pliers, sets rods in place, spaces and secures reinforcing rods. May bend steel rods with hand tools or operate a rod-bending machine; may reinforce concrete with wire mesh; may perform other related duties.
 - 7) Ironworker (Structural): Performs any combination of the following duties to set beams, hang diaphragms, install bolts, torque bolts, test bolts, raise, place and unite girders, columns and other structural steel members to form completed structures or structure frameworks, working as a member of a crew; sets up hoisting equipment for raising and placing structural

steel members; fastens steel members to cable of hoist using chain, cable or rope; signals worker operating hoisting equipment to lift and place steel members. Guides member using guy line (rope) or rides on member to guide it into position. Reads plans; rigs, assembles and erects structural members requiring riveting or welding. May perform other related duties.

- 8) Lead Abatement Worker: All work associated with lead abatement shall be classified as "Lead Abatement Worker."
- 9) Stone Mason: Builds stone walls, as well as set stone exteriors and floors, lays/sets all cut stone, marble, slate, or stone, with or without mortar. They work with natural cut stone, such as marble, granite, limestone and artificial stone made of concrete, marble chips, or other masonry materials.
- 10) Sweeper/Broom Operators: Whenever Sweeper or Broom does not appear in the Wage Determination, contractors may use the Truck Driver classification for this service if the equipment used is of the over the road type (only). However, anytime the contract has an established classification/rate for "Sweeper or "Broom," this classification must be used and the minimum rate, as it appears in the contract, shall apply.
- 11) Traffic Coordinator: Performs sign placement and maintenance, including proper set up and relocation of construction sign packages and message boards; designs lane closures in accordance with local, state, and Federal requirements. Please do not confuse this classification with Flagger.

6. **Mandatory Training.** Prime Contractors who fail to obtain an annual average (based on the calendar year) of at least 50% "Satisfactory" ratings on all OFC Compliance Field Audit Reports will be required to attend a mandatory 4-hour Contractor Compliance Training Class each spring (as scheduled by the OFC). A principal owner (or executive officer of the company) and his/her payroll accountant shall attend. Note: Compliance ratings on all projects will be averaged whenever a Prime Contractor has multiple projects.

7. **Temporary Suspensions.**

- a. Any Contractor, Subcontractor, or Lower-tier Subcontractor found to be in violation of FHWA Form 1273, Required Contract Provisions, made part of its contract, or has failed to comply with OFC Field Audit requirements, will be required to take corrective action before participating in future projects funded by the Department. Corrective action will include, but not limited to, the submission of certified payrolls or other records and reports necessary to verify compliance with the Provisions.
- b. Any Contractor, Subcontractor or Lower-tier Subcontractor found to have repeatedly violated the FHWA Form 1273, Required Contract Provisions, may be required to complete 4-hours of Federal Contract Compliance Training conducted by the NHDOT Office of Federal Compliance. When mandated, a principal owner and/or company executive and his/her payroll accountant shall attend. Federal Contract Compliance Training must be completed before participation on future projects is authorized. This requirement does not relieve the Contractor of its

obligations under the prime contract, nor does it prevent the Department from seeking other remedies or enforcement action, as provided by the governing Rules, Laws, and Federal Regulations.

- c. Companies will be notified of suspensions in writing. Actions the company must take to have participation privileges restored will be clearly indicated. Companies will also be advised that if a satisfactory response is not received within 30 days of receipt of the suspension notice, the company will be considered "non-responsive." In cases where companies are non-responsive, and unpaid wages on the part of the subcontractor or lower-tier subcontractor are involved, the matter will then be deferred to the Prime Contractor for payment of wages as provided in Form FHWA 1273, Required Contract Provisions, Section I, Paragraph 3.
8. **Right To Withhold Payments.** The Department may withhold payments claimed by the Contractor on account of:
- a. Failure of the Contractor to make payments to Subcontractors for materials or labor.
 - b. Regulatory non-compliance or enforcement.
 - c. Failure to comply with NHDOT Office of Federal Compliance Field Audit Report requirements.
 - d. Failure to comply with monthly reporting requirements, as applicable.
 - e. For projects with an OJT requirement, failure to submit OJT 1, On-The-Job Training Acknowledgement and Statement of Intent within 30 days of the project start date.
 - f. Failure to submit closeout documentation.
 - g. All other causes that the Department reasonably determines negatively affect the State's interest.
9. **Final Payment Release.** Once final project records are transferred to the NHDOT Office of Federal Compliance, a final review shall be performed to determine compliance with the Federal provisions. Release of any final payment shall not be made to the Contractor until the Office of Federal Compliance issues a payment release letter (ok to pay) certifying:
- a. All required payrolls, labor, and EEO documentation have been received and deemed complete and correct.
 - b. DBE requirements stipulated in the Contract and/or the Required Contract Provisions have been fulfilled.
10. **Deposits and Escrows.** Every attempt is made to complete compliance actions and resolve any disputes before the project is completed and final payments are made. Sometimes, however, corrective actions or disputes continue after completion and provisions must be made to ensure that funds are available to pay any wage restitution that is ultimately found due. In these cases, the project can proceed to final closing provided the Prime Contractor, from payments already provided him/her, provides written evidence a deposit of an amount equal to the potential liability for wage restitution and liquidated damages, if applicable, has

been deposited in an *escrow account*. When a final decision is rendered, the Prime Contractor makes disbursements from the account in accordance with the decision. Deposit/escrow accounts are established for one or more of the following reasons:

- a. Where the parties have agreed to amounts of wage restitution that are due but the employer has not yet furnished evidence that all the underpaid workers have received their back wages. The deposit is equal to the amount of restitution due to workers lacking payment evidence. As proper documentation is received, an amount corresponding to the documentation is returned to the depositor. Amounts for any workers who cannot be located are held in the escrow account for three (3) years. Amounts remaining in the account not disbursed by the end of this three-year period shall be returned to the Prime Contractor.
- b. Where underpayments are suspected or alleged and an investigation has not yet been completed. The deposit is equal to the amount of wage restitution and liquidated damages, if applicable, that is estimated to be due. If the final determination of wages due is less than the amount estimated and placed in the escrow account, the escrow will be reduced to the final amount and the difference will be returned to the depositor. If the parties agree to the investigative findings, the amounts due to workers will be disbursed from the escrow account in accordance with the schedule of wages due. Amounts for unfound workers will be retained for a period of three (3) years and subsequently disbursed to the depositor as described above in Paragraph 7a.
- c. Where the parties are waiting for the outcome of an administrative hearing that has been or will be filed contesting a final determination of wages due. The deposit shall be equal to the amount of wage restitution and liquidated dates, if applicable, that have been determined to be due. Once the final decision is rendered, disbursements from the escrow account are made in accordance with the decision.

Direct questions relating to any of the information above to the NHDOT Office of Federal Compliance (603-271-6752).

SUPPLEMENTAL SPECIFICATION

AMENDMENT TO SECTION 109 -- MEASUREMENT AND PAYMENT

AMENDMENT TO SUBSECTION 109.09 – PAYMENTS TO SUBCONTRACTORS

109.09 Prompt Payment to Subcontractors.

The Prime Contractor shall pay all Subcontractors for the work performed no later than 21 calendar days from the date the Prime Contractor received payment from the Department for said work, including materials in accordance with 109.07 and/or 109.08 paid for in the progress payments. Subcontractors are required to pay their Subcontractors and/or material suppliers, within 21 calendar days from the date they receive payment for satisfactory work performed or supplies received. This Prompt Pay requirement shall be made part of all subcontracts and agreements.

If the Prime Contractor believes that any portion of the payment should be withheld from the Subcontractor, the Prime Contractor shall notify the NHDOT Contract Administrator in writing, prior to the estimate being processed. The NHDOT Office of Federal Compliance shall be made part of this notification. The NHDOT may withhold payment for the portion of work in dispute pending resolution.

This prompt payment provision is a requirement of 49 CFR 26.29 and does not confer third-party beneficiary right or other direct right to a Subcontractor against the Department. This provision applies to both DBE and non-DBE Subcontractors.

Satisfactory Work Performed. Satisfactory work performed shall be defined for purposes of this prompt payment provision as:

1. Upon review, the Engineer finds the work completed in accordance with the contract, plans and specifications, and;
2. Required paperwork, for Progress and Partial payments, including material certifications and payrolls, has been received.

The determination of whether work meets the standards set forth above is the responsibility of the Engineer. If the Subcontractor becomes insolvent after it satisfactorily performs work as defined above but before payment is due, the obligation to pay is not extinguished. (Payment may have to be made to the bankruptcy trustee or to an escrow account for the benefit of creditors.)

The Prime Contractor must include, in all subcontract agreements, notices to Subcontractors of their right to prompt payment, and of the Department's policy prohibiting Prime Contractor's from holding retainage from Subcontractors under 49 CFR 26.29.

Failure of a Prime Contractor or a Subcontractor to comply with these prompt payment provisions may result in sanctions.

Non-Payment Claims. All notifications of failure to meet prompt payment provisions shall be referred by Subcontractors, in writing, to the NHDOT Office of Federal Compliance with a copy supplied to the respective Contract Administrator.

Payment Certifications. The Prime Contractor or any Subcontractor who receives payment for work and/or materials (specifically supplied to the project in excess of \$10,000) shall submit a "Monthly Prompt Pay Certification," OFC Form 18, to the NHDOT Office of Federal Compliance no later than the 10th calendar day of each month.

TE/CMAQ Program
Construction Proposal

It is proposed:

To execute the Contract and begin work within 10 days from the date specified in the "Notice to Proceed" and to prosecute said work so as to complete the _____ and its appurtenances on or before _____.

To furnish a Contract Bond in the amount of 100 per cent of the Contract award, as security for the construction and completion of the _____ and its appurtenances in accordance with the Plans, Specifications and Contract. The Contractor's attention is called to Section 103.05 of the NHDOT Standard Specifications for road and bridge construction which provides the following guidance: unless specifically waived in the Proposal, upon execution of the Contract, the successful Bidder shall furnish the Agency a surety bond or bonds equal to the sum of the Contract amount. The form of the bond(s) shall be acceptable to the Agency and the bonding Company issuing the bond(s) shall be licensed to transact business in the State of New Hampshire, and....

To certified that the Bidder, in accordance with the requirements of 103.06 and 108.01, intends to sublet, assign, sell, transfer or otherwise dispose of one or more portions of the work and (1) has contacted the appropriate listed disadvantaged businesses and afforded such disadvantaged businesses equal consideration with non-disadvantaged business for all work the Bidder currently proposes to sublet, assign, sell, transfer or otherwise dispose of, (2) may contact additional appropriate disadvantage businesses and will afford such businesses equal consideration with non-disadvantaged businesses for all work the Bidder in the future proposes to sublet, assign, sell, transfer or otherwise dispose of, and (3) will complete enclosed "DISADVANTAGED BUSINESS ENTERPRISE COMMITMENT FORM" and Letters of Intent for each disadvantaged business. The name of the person in the Bidder's organization who has been designated as the liaison officer to administer the disadvantaged business enterprise program is:

(To be completed by the Bidder)

To guarantee all of the work performed under this Contract to be done in accordance with the Specifications and in good and workmanlike manner, and to renew or repair any work which may be rejected, due to defective materials or workmanship, prior to final completion and acceptance of the project.

Enclosed herewith find certified check or bid bond in the amount of _____ dollars (\$ _____), made payable to the Agency as a proposal guarantee which it is understood will be forfeited in the event the Contract is not executed, if awarded by the Agency to the undersigned.

Certification Regarding Debarment, Suspension, and Other Responsibility Matters – Primary Covered Transactions.

(1). The prospective primary participant certifies to the best of its knowledge and belief, that it and all its principals: (a) Are not presently debarred, suspended, proposed for debarment, declared ineligible, or voluntarily excluded from covered transactions by any Federal department or agency; (b) Have not within a three-year period preceding this proposal been convicted of or had a civil judgment rendered against them for commission of fraud or a criminal offense in connection with obtaining, attempting to obtain, or performing a public (Federal, State or Local) transaction or contract under a public transaction; violation of Federal or State antitrust statutes or commission of embezzlement, theft, forgery, bribery, falsification or destruction of records, making false statements, or receiving stolen property; (c) Are not presently indicted for or otherwise criminally or civilly charged by a governmental entity (Federal, State or Local) with commission of any of the offenses enumerated in Paragraph (1) (b) of this certification and (d) Have not within a three-year period preceeding this application/proposal had one or more public transactions (Federal, State or Local) terminated for cause or default. (2). Where the prospective primary participant is unable to certify to any of the statements in this certification, such prospective participant shall attach an explanation to this proposal.

Contract Affidavit

I/We declare under penalty of perjury under the laws of the United States and the State of New Hampshire that, in accordance with the provisions of Title 23 USC, Section 112(c), have not either directly or indirectly entered into any agreement, participated in any collusion or otherwise taken any action in restraint of free competitive bidding in connection with this Proposal.

Dated: _____

(If a firm or individual)

Signature of Bidder _____

By _____

Address of Bidder _____

Names and Addresses of Members of the Firm:

(If a Corporation)

Signature of Bidder _____

Title _____

By _____

Business Address _____

Incorporated under the laws of the State of _____

Names of Officers:

President _____
Name Address

Secretary _____
Name Address

Treasurer _____
Name Address

11/07/12

Page 1 of 2

SUPPLEMENTAL SPECIFICATION

SECTION 107 -- LEGAL RELATIONS AND RESPONSIBILITIES TO PUBLIC

SUBSECTION 107.01 – LAWS TO BE OBSERVED

The intent of this Supplemental Specification is to clarify Bulletin Board requirements.

Replace 107.01's third paragraph titled *Bulletin Board Requirements* with the following:

Bulletin Board Requirements: The Contractor shall erect and maintain a bulletin board on which to post the notices, rates, and related items that are required to be posted. The board shall be a **minimum of 4 foot by 8 foot in order to** allow sufficient space, without overlapping, for both State and Federal poster/information, as required. Additional work classifications and their rates, requested by the Contractor and subsequently approved by the USDOL, shall also be posted. Bulletin boards shall be an enclosure and the posted documents shall be protected from the elements by glass or Plexiglas. Boards shall be erected on the site of work, be placed in a conspicuous and accessible location where it can be easily seen by all workers. **If placing the bulletin board on the site of work is not feasible, either for safety reasons or due to the work taking place, the Contractor may recommend placing it in an adjacent location subject to NHDOT approval. If the NHDOT deems the alternate location as unsuitable (the location is too distant or will not be utilized by all subcontractors, etc.), the NHDOT may instead require the use of employee bulletin board handouts in accordance with FHWA policy. Contractors have two options for posters: Option 1 - Using "all-in-one" Federal and State posters; or Option 2 - Arranging posters in a predetermined manner (see attached) as provided by the NHDOT.** The bulletin board shall remain the property of the Contractor and shall be removed upon completion of the Work.

New Hampshire Department of Transportation Bulletin Board Diagram

(Revision 11-8-12)

NHDOT PROJECT: (NAME) (NUMBER)

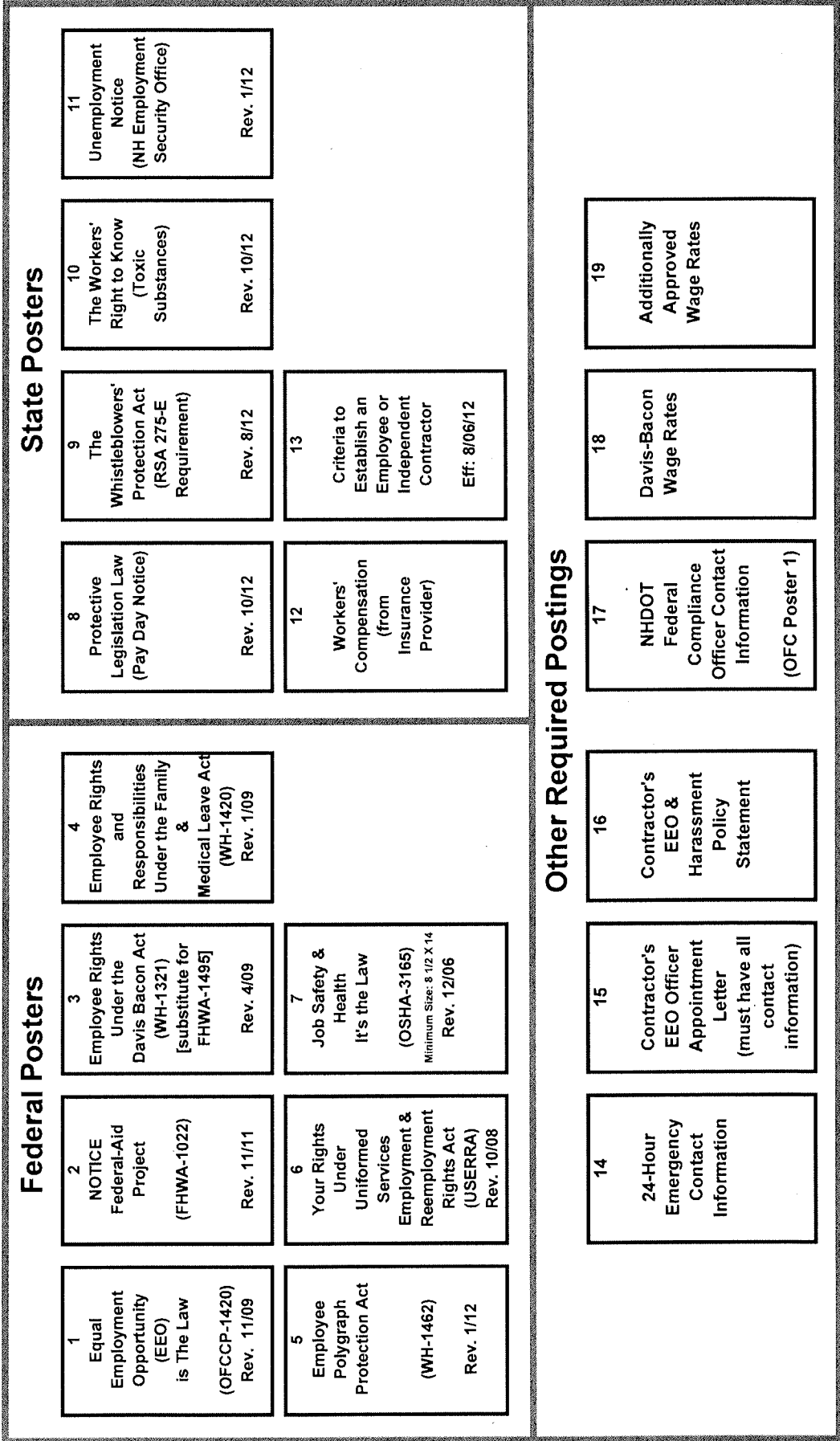

Other Required Postings

12/05/12

SPECIAL ATTENTION**CONVICT PRODUCED MATERIAL**

In accordance with the requirements of the Federal regulations (23 U.S.C. 114(b)(2), 23 CFR 635.417), essentially all convict produced material is prohibited from Federal-aid highway construction projects. More specifically, materials produced after July 1, 1991, by convict labor, may only be incorporated in a Federal-aid construction projects if: 1) such materials have been produced by convicts who are on parole, supervised release, or probation from a prison; or 2) such material has been produced in a qualified prison facility, e.g., prison industry, with the amount produced during any 12-month period, for use in Federal-aid projects, not exceeding the amount produced, for such use, during the 12-month period ending July 1, 1987*.

* Because the Department, Federal Highway Administration, nor New Hampshire Correctional Industries can produce documents to meet condition 2 above, this condition cannot be met for New Hampshire convict produced material.

PERMITS



The State of New Hampshire
DEPARTMENT OF ENVIRONMENTAL SERVICES



Thomas S. Burack, Commissioner

WETLANDS AND NON-SITE SPECIFIC PERMIT 2014-01242

Permittee: City of Portsmouth
680 Peverly Hill Rd.
Portsmouth, NH 03801

Project Location: Daniel Street, Portsmouth
Portsmouth Tax Map/Lot No. 105 / 3

Waterbody: Atlantic Ocean

**NOTE--
CONDITIONS**

APPROVAL DATE: 10/24/2014

EXPIRATION DATE: 10/24/2019

Based upon review of the above referenced application, in accordance with RSA 482-A and RSA 485-A:17, a Wetlands Permit and Non-Site Specific Permit was issued. This permit shall not be considered valid unless signed as specified below.

PERMIT DESCRIPTION: Impact 2,294 sq. ft. of tidal waters to construct a pile supported timber pier for a public park.

Approve as compensatory mitigation the restoration of 15,115 sq. ft. of saltmarsh in North Mill Pond.

**THIS APPROVAL IS SUBJECT TO THE FOLLOWING PROJECT SPECIFIC
CONDITIONS:**

1. All work shall be in accordance with plans by Waterfront Engineers, LLC dated August 27, 2014, as received by the Department on September 23, 2014.
2. Any future work in jurisdiction as specified in RSA 482-A on this property will require a new application and approval by the Department of Environmental Services ("DES") Wetlands Bureau.
3. This permit shall not be effective until recorded at the Rockingham County Registry of Deeds office by the permittee. A copy of the recorded permit shall be submitted to the DES Wetlands Bureau prior to construction.
4. Appropriate siltation/erosion/turbidity controls shall be in place prior to construction, shall be maintained during construction, and shall remain in place until the area is stabilized.
5. Within three days of final grading or temporary suspension of work in an area that is in or adjacent to wetlands or surface waters, all exposed soil areas shall be stabilized by seeding and mulching during the growing season, or if not within the growing season, by mulching with tack or netting and pinning on slopes steeper than 3:1.
6. Work shall be done during low tide.
7. Work shall be conducted in a manner so as to minimize turbidity and sedimentation to surface waters and wetlands.

DES Web site: www.des.nh.gov

P.O. Box 95, 29 Hazen Drive, Concord, New Hampshire 03302-0095

Telephone: (603) 271-3503 • Fax: (603) 271-6588 • TDD Access: Relay NH 1-800-735-2964

8. Work shall be conducted in a manner that avoids excessive discharges of sediments to fish spawning areas.
9. Construction equipment shall be inspected daily for leaking fuel, oil and hydraulic fluid prior to entering surface waters or wetlands.
10. Faulty equipment shall be repaired prior to entering jurisdictional areas.
11. The contractor shall have appropriate oil spill kits on site and readily accessible at all times during construction and each operator shall be trained in its use.
12. All refueling of equipment shall occur outside of surface waters or wetlands.

Wetland restoration/construction:

13. This permit is contingent upon the restoration of 15,115 sq. ft. of saltmarsh in accordance with plans received by DES on September 23, 2014.
14. The schedule for construction of the mitigation area shall coincide with site construction unless otherwise considered and authorized by the Wetlands Bureau.
15. The mitigation area shall be properly constructed, monitored, and managed in accordance with approved final mitigation plans.
16. Saltmarsh restoration areas shall be properly constructed, landscaped, monitored and remedial actions taken that may be necessary to create functioning wetland areas. Remedial measures may include replanting, relocating plantings, removal of invasive species, changing soil composition and depth, changing the elevation of the wetland surface, and changing the hydrologic regime.
17. The permittee shall designate a qualified professional who will be responsible for monitoring and ensuring that the mitigation areas are constructed in accordance with the mitigation plan. Monitoring shall be accomplished in a timely fashion and remedial measures taken if necessary. The Wetlands Bureau shall be notified in writing of the designated professional prior to the start of work and if there is a change of status during the project.
18. The permittee shall notify DES and the local conservation commission in writing of their intention to commence construction no less than 5 business days prior to construction.
19. The permittee or a designee shall conduct a follow-up inspection after the first growing season, to review the success of the mitigation area and schedule remedial actions if necessary. A report outlining these follow-up measures and a schedule for completing the remedial work shall be submitted by December 1 of that year. Similar inspections, reports and remedial actions shall be undertaken in at least the second and third years following the completion of each mitigation site.
20. Saltmarsh restoration areas shall have at least 75% successful establishment of wetlands vegetation after two (2) growing seasons, or shall be replanted and re-established until a functional wetland is replicated in a manner satisfactory to the DES Wetlands Bureau.
21. Wetland soils from areas vegetated with purple loosestrife shall not be used in the wetland creation site. The potential for the establishment of the invasive species should be considered in other areas where spoils may be spread to limit its further establishment.

22. The permittee shall attempt to control invasive, weedy species such as purple loosestrife (*Lythrum salicaria*) and common reed (*Phragmites australis*) by measures agreed upon by the Wetlands Bureau if the species is found in the mitigation areas during construction and during the early stages of vegetative establishment.
23. A post-construction report documenting the status of the completed project with photographs shall be submitted to the Wetlands Bureau within 60 days of the completion of construction.

GENERAL CONDITIONS THAT APPLY TO ALL DES WETLANDS PERMITS:

1. A copy of this permit shall be posted on site during construction in a prominent location visible to inspecting personnel;
2. This permit does not convey a property right, nor authorize any injury to property of others, nor invasion of rights of others;
3. The Wetlands Bureau shall be notified upon completion of work;
4. This permit does not relieve the applicant from the obligation to obtain other local, state or federal permits, and/or consult with other agencies as may be required (including US EPA, US Army Corps of Engineers, NH Department of Transportation, NH Division of Historical Resources (NH Department of Cultural Resources), NHDES-Alteration of Terrain, etc.);
5. Transfer of this permit to a new owner shall require notification to and approval by DES;
6. This project has been screened for potential impacts to **known** occurrences of rare species and exemplary natural communities in the immediate area. Since many areas have never been surveyed, or have received only cursory inventories, unidentified sensitive species or communities may be present. This permit does not absolve the permittee from due diligence in regard to state, local or federal laws regarding such communities or species.
7. Review enclosed sheet for status of the US Army Corps of Engineers' federal wetlands permit.

APPROVED: _____

David Price
DES Wetlands Bureau

=====

BY SIGNING BELOW I HEREBY CERTIFY THAT I HAVE FULLY READ THIS PERMIT AND AGREE TO ABIDE BY ALL PERMIT CONDITIONS.

OWNER'S SIGNATURE (required)

CONTRACTOR'S SIGNATURE (required)



REPLY TO
ATTENTION OF

DEPARTMENT OF THE ARMY
NEW ENGLAND DISTRICT, CORPS OF ENGINEERS
698 VIRGINIA ROAD
CONCORD, MASSACHUSETTS 01742-2761

December 5, 2014

Regulatory Division
CENAE-R-PEC
Permit Number: NAE-2014-02278

City of Portsmouth
680 Peverly Hill Road
Portsmouth, Massachusetts 03801

Dear Applicant:

This is to inform you that we have reviewed your application to conduct activities as described on the attached NH State Letter 2014-01242, dated October 31, 2014.

Based on our review of the information you provided to the NHDES Wetlands Bureau, we have determined that your project, will have only minimal individual or cumulative environmental impacts on waters of the United States, including wetlands. **We hereby conditionally authorize your project under the attached Federal permit known as the New Hampshire State Programmatic General Permit (NHSPGP) pending final concurrence with the Wetlands Bureau approval by the Governor & Executive Council (G&C).** This work must be performed in accordance with the terms and conditions of the PGP including the following **Special Condition(s)**.

Special Condition No. 1. To avoid impacts to Atlantic Sturgeon (*Acipenser oxyrinchus*) and the Shortnose Sturgeon (*Acipenser brevirostrum*), installation of piles shall comply with one of the four methods described in items a through d below. The same method does not have to be used for all piles installed.

- a. Piles shall be installed in-the-dry during periods of low water or, if they are installed in the water, they shall be installed only between Nov. 8 and Apr. 9.
- b. Piles shall be drilled and pinned to ledge.
- c. Vibratory hammers shall be used to install wood, concrete or steel piles of any size and quantity.
- d. If piles are installed by impact hammers, no more than one impact hammer shall be used at a time and no more than 49 piles shall be installed per day. The impact hammer method of installation can be used for wood piles of any size but only for concrete piles less than or equal to 18 inches in diameter and only for steel piles less than 12 inches in diameter. The impact hammer shall weigh no more than 3,000 pounds and a wood cushion shall be used between the hammer and steel pile.

For installation methods b and d above, in-water noise levels shall not exceed

187 decibels (dB) sound exposure level (SEL) in reference to (re) 1 micro Pascal (μPa) or 206 dB peak re $1\mu\text{Pa}$ at a distance greater than 10 meters from the pile being installed and in-water noise levels greater than 155 dB peak re $1\mu\text{Pa}$ shall not last longer than 12 consecutive hours on any given day and a 12- hour recovery period (i.e., in-water noise level below 155 dB peak re $1\mu\text{Pa}$) shall be provided between work days.

Special Condition No. 2. Mitigation shall be carried out as referenced in the NH State Letter, file # 2014-01242, dated October 31, 2014 and as described in the document entitled "Brewster Street Project and Harborwalk Project-Wetland Mitigation Plan" dated "June 10, 2014".

You are responsible for complying with all of the PGP's requirements. Please review the attached PGP carefully to familiarize yourself with its contents. You should ensure that whoever does the work fully understands the requirements and that a copy of the permit document is at the project site throughout the time the work is underway. A copy of the PGP can also be found at http://www.nae.usace.army.mil/Regulatory/SGP/NH_PGP.pdf.

This authorization expires on August 03, 2017 unless the PGP is modified, suspended, or revoked before that. You must complete the work authorized herein by that date. If you do not, you must contact this office to determine the need for further authorization before continuing the activity. We recommend that you contact us *before* this authorization expires to discuss a time extension or reissuance of the authorization.

If you change the plans or construction methods for work within our jurisdiction, please contact us immediately to discuss modification of this authorization. This office must approve any changes before you undertake them.

This authorization requires you to complete and return the enclosed Compliance Certification Form within one month following the completion of the authorized work.

Please note that if your proposal is vetoed or modified by the G&C, making it different from that which the NHDES Wetlands Bureau approved on the date stated in the first paragraph

of this letter, you must re-submit a complete application to this office for review and processing in accordance with the terms and conditions of the then-current NHSPGP.

This authorization presumes that the work as described above and as shown on your plans is in Waters of the U.S. Should you desire to appeal our jurisdiction, please submit a request for an approved jurisdictional determination in writing to this office.

This permit does not obviate the need to obtain other Federal, state or local authorizations required by law, including those listed in the PGP. Performing work not specifically authorized by this determination or failing to comply with all the terms and conditions of the PGP may subject you to the enforcement provisions of Corps regulations.

We continually strive to improve our customer service. In order for us to better serve you, we would appreciate your completing our Customer Service Survey located at http://www.nae.usace.army.mil/reg/Customer_Service_Survey.pdf.

If you have questions concerning this, please contact Richard Kristoff of my staff at (978) 318-8157, (978) 318-8335/8338, (800) 343-4789, or, if calling from within Massachusetts, (800) 362-4367. His e-mail address is Richard.C.Kristoff@usace.army.mil.

Sincerely,

Frank J. DelGiudice
Chief, Permits & Enforcement Branch
Regulatory Division

Enclosures

Copies Furnished:

New Hampshire Department of Environmental Services, Wetlands Bureau, Attn: Mr. Collis Adams, P.O. Box 95, 29 Hazen Drive, Concord, New Hampshire 03302-0095

Duncan Mellor, Waterfront Engineers LLC, 3 Linda Lane, Stratham, New Hampshire 03885, dmellor@waterfrontengineers.com

HARBORWALK PARK DANIEL STREET AT MEMORIAL BRIDGE PHASE 2 PORTSMOUTH, NEW HAMPSHIRE

FEBRUARY 12, 2015



OWNER CITY OF PORTSMOUTH
1 JUNKINS AVE, PORTSMOUTH, NH

STRUCTURAL/WATERFRONT ENGINEER WATERFRONT ENGINEERS LLC
3 LINDA LANE, STRATHAM, NH

SITE CIVIL ENGINEER HAIGHT ENGINEERING PLLC
181 WATSON ROAD, DOVER, NH

LANDSCAPE ARCHITECT G2+1, LLC
70 NEW ROAD, SAILSBURY, NH

SHEET INDEX

PHOTOS
SITE PLAN
OVERLOOK DECK PLAN
OVERLOOK PILE & FRAMING PLAN
OVERLOOK SECTIONS
WF DETAILS 1
WF DETAILS 2
WF DETAILS 3
SEAWALL DETAILS

SHEET

WF-1
WF-2
WF-3
WF-4
WF-5
WF-6
WF-7
WF-8
WF-9

NOTE: PHASE 1 ARCHER-WESTERN AS-BUILT DRAWINGS AND DETAILS ARE PROVIDED FOR REFERENCE AND INCIDENTAL DETAILS, INCLUDING BENCH DETAILS



SEATING BLOCK RESET

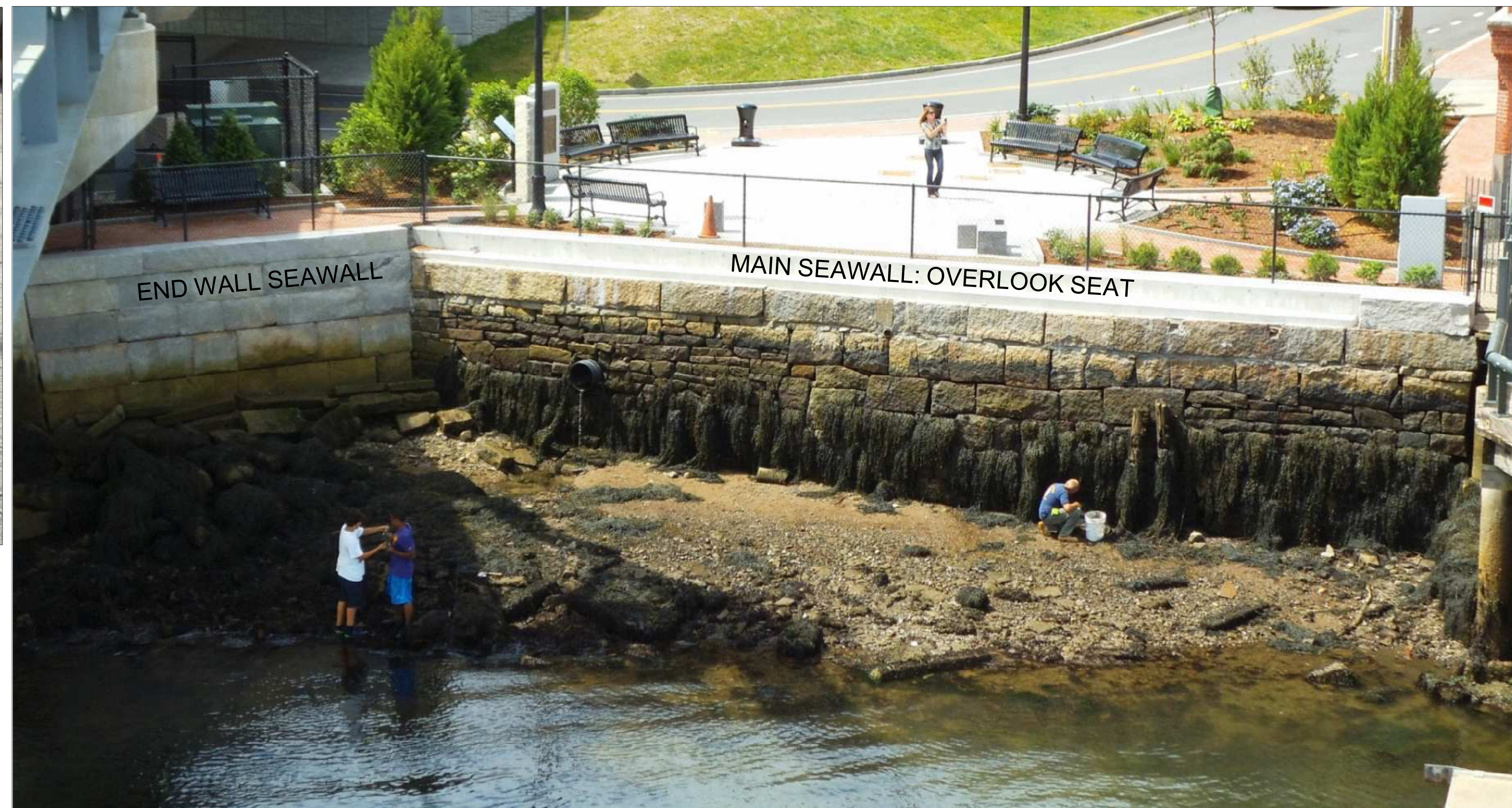

VIEW OF PHASE 1 PARK

Harborwalk Park Tides

- 100 Yr = 9.0'
- HOTL = 6.64'
- NEC Datum = 6.6'
- MHHW = 4.98'
- MHW = 4.57'
- NAVD 88 = 0.77'
- NGVD 29 = 0.00'
- MLW = -3.54'
- MLLW = -3.86'

- Ref.
1. NOAA Seavey Is Sta 8419870 for 1983-2001 tidal epoch
 2. NFPA NEC
 3. FEMA Flood maps

NOT TO SCALE
 PHOTOS TAKEN PRIOR TO
 PUNCHLIST COMPLETION &
 EXISTING CONDITIONS MAY
 VARY SOMEWHAT

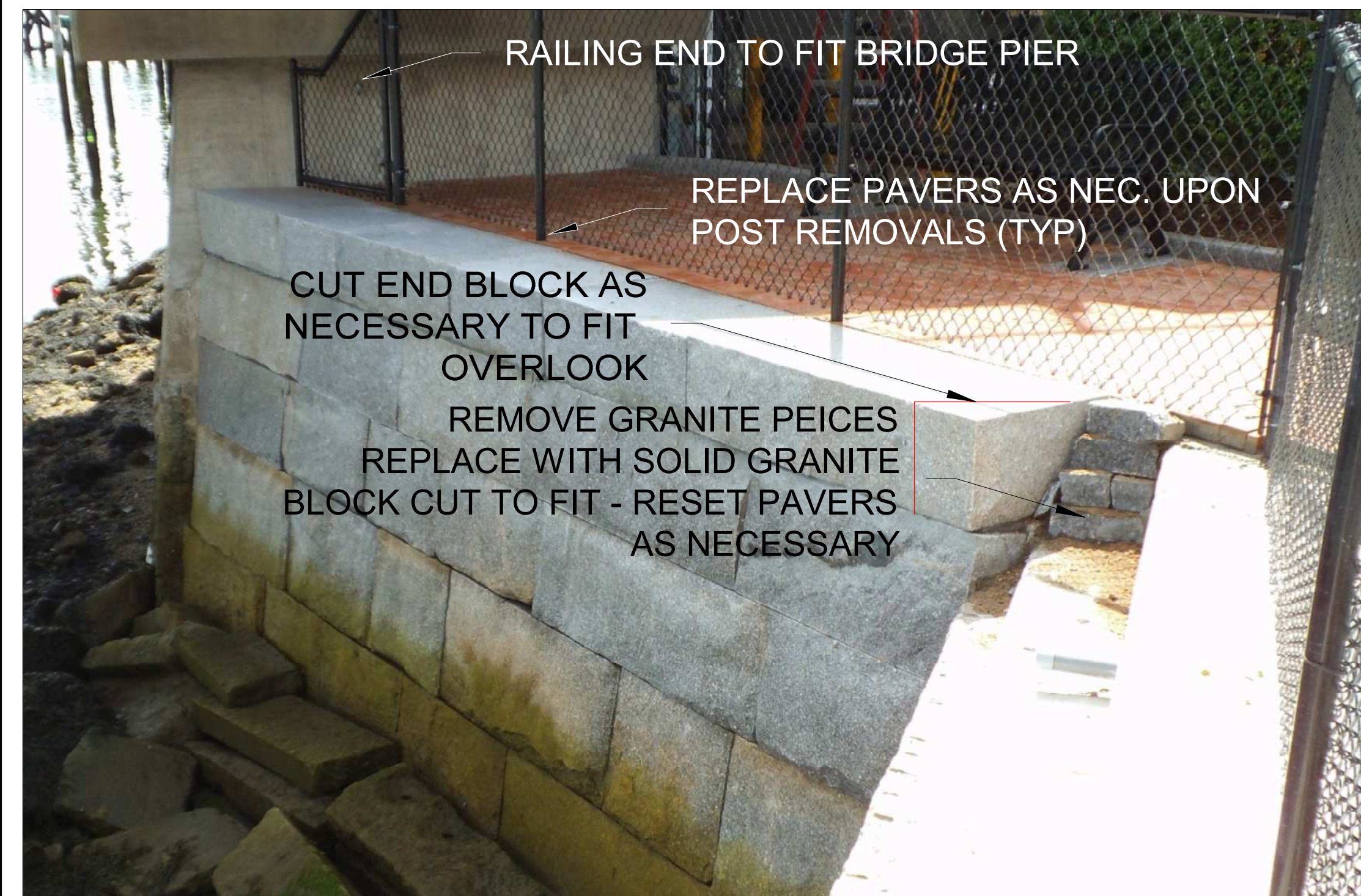

EAST END OF SEAT



SEAWALL SEAT FOR OVERLOOK

WATERFRONT ENGINEERS LLC

3 Linda Lane
 Stratham, New Hampshire
 (603) 772-3706
 www.waterfrontengineers.com

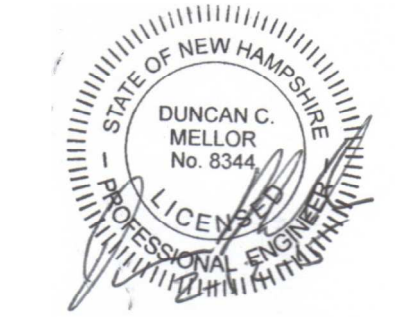

Date: 02/12/15
 Scale: As Shown
 Designer: DCM
 Approved by: DCM
 Project No:
 File:

HARBORWALK PARK

DANIEL STREET AT
 MEMORIAL BRIDGE



CITY OF PORTSMOUTH
 DEPARTMENT OF PUBLIC WORKS
 680 Peverly Hill Road

WATERFRONT ENGINEERS LLC

3 Linda Lane
 Stratham, New Hampshire
 (603) 772-3706
 www.waterfrontengineers.com

PHOTOS

WF - 1

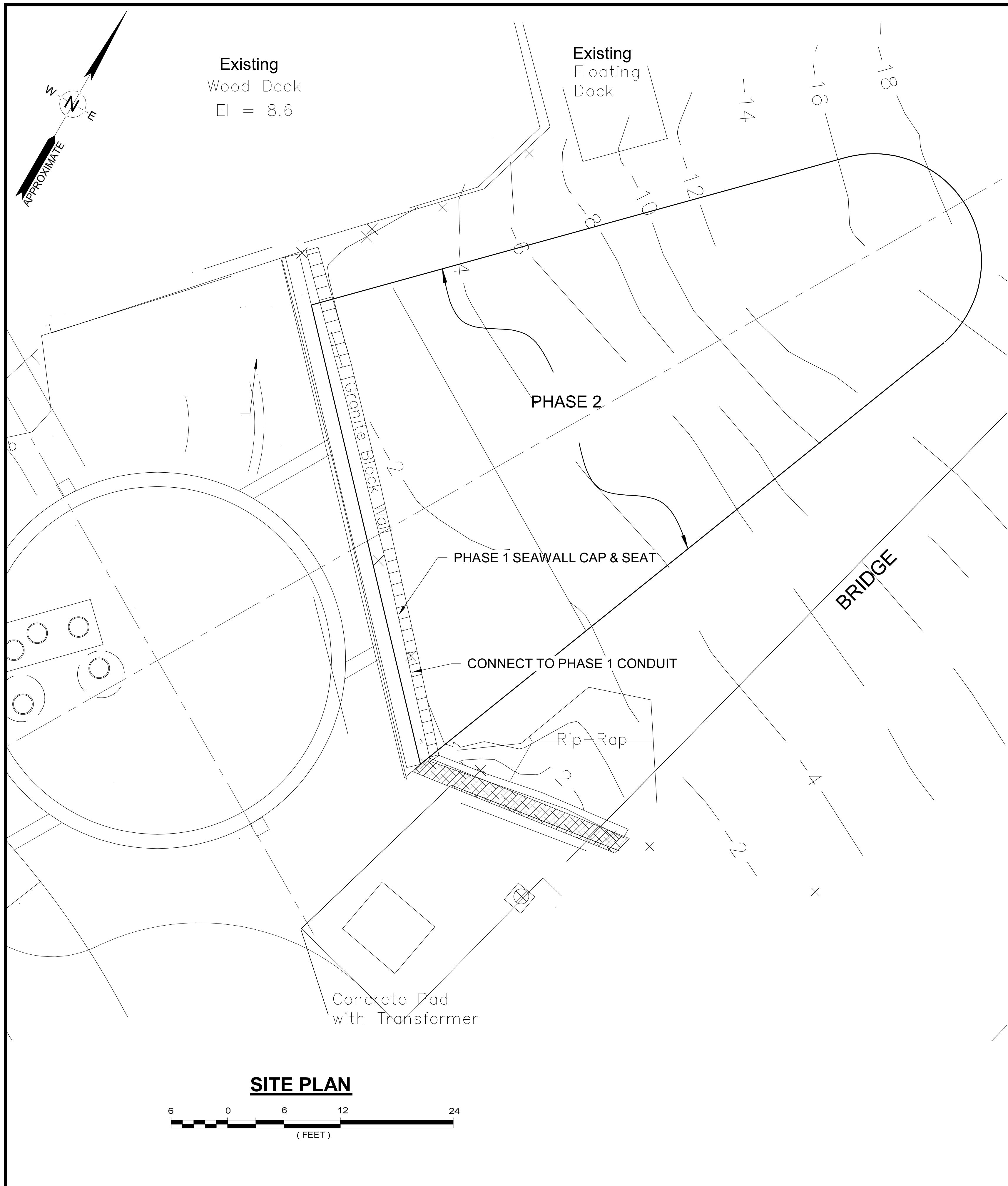

GENERAL NOTES:

1. ALL DIMENSIONS, LAYOUT, ELEVATIONS & CONDITIONS SHALL BE VERIFIED IN THE FIELD BY THE CONTRACTOR ANY DISCREPANCIES SHALL BE BROUGHT TO THE ATTENTION OF THE ENGINEER BEFORE ORDERING MATERIALS OR PROCEEDING WITH THE AFFECTED PART OF THE WORK. IT WAS NOT POSSIBLE FOR THE OWNER AND/OR ENGINEER TO OBSERVE ALL EXISTING CONDITIONS AND UNFORESEEN CONDITIONS ARE EXPECTED TO BE DISCOVERED.
2. IT IS THE CONTRACTOR'S SOLE RESPONSIBILITY TO DETERMINE DEMOLITION, CONSTRUCTION, ERECTION PROCEDURES AND SEQUENCE TO INSURE THE SAFETY OF THE FACILITIES AND THEIR COMPONENTS DURING DEMOLITION AND ERECTION. THIS INCLUDES THE ADDITION OF NECESSARY FASLSEWORK, SHORING, SHEETING, TEMPORARY BRACING, GUYS OR TIEDOWNS. SUCH MATERIAL SHALL REMAIN THE PROPERTY OF THE CONTRACTOR AFTER COMPLETION OF THE PROJECT.
3. THE CONTRACTOR SHALL BE RESPONSIBLE FOR ANY DAMAGE DONE TO STRUCTURES, UTILITIES, AND VESSELS OR INJURIES TO THE PUBLIC DURING THE CONSTRUCTION PHASE CAUSED BY HIMSELF, HIS SUBCONTRACTORS OR ANY EMPLOYEES OF THE SAME. CONTRACTOR SHALL FURNISH AND INSTALL ALL TEMPORARY FACILITIES FOR THE PROTECTION OF THE WORK, WORKERS AND PUBLIC SAFETY. CONSTRUCTION FENCE SHALL BE INSTALLED AND MAINTAINED AROUND THE WORK AREA AT ALL TIMES FROM START TO COMPLETION OF THE WORK. PROVIDE BARGE LIGHTS AS REQUIRED.
4. ALL APPLICABLE FEDERAL, STATE AND MUNICIPAL REGULATIONS AND PERMITS SHALL BE FOLLOWED, INCLUDING THE FEDERAL DEPARTMENT OF LABOR, SAFETY, AND HEALTH, U.S. ARMY CORPS OF ENGINEERS, US COAST GUARD, STATE/LOCAL WETLANDS CONTROL. IT IS THE CONTRACTOR'S RESPONSIBILITY TO PROVIDE AND MAINTAIN ENVIRONMENTAL CONTROLS AS REQUIRED BY FEDERAL, STATE AND MUNICIPAL REGULATIONS AND PERMITS. ENVIRONMENTAL CONTROLS SHALL INCLUDE BUT NOT BE LIMITED TO EROSION, TURBIDITY AND DUST.
5. STANDARD CONSTRUCTION WORK HOURS ON THE SITE SHALL BE BETWEEN 7 AM AND 7 PM TO MINIMIZE NOISE AND LIGHT DISTURBANCE TO NEARBY RESIDENTIAL PROPERTIES.
6. THE CONTRACTOR SHALL MAINTAIN RECORD DRAWINGS DURING CONSTRUCTION THAT NOTE ALL CHANGES FROM THE CONTRACT DRAWINGS AND THESE RECORD DRAWINGS SHALL BE TURNED OVER TO THE OWNER UPON COMPLETION OF THE WORK.

SEQUENCE NOTES:

1. MEANS AND METHODS ARE THE SOLE RESPONSIBILITY OF THE CONTRACTOR, HOWEVER THE CONTRACTOR SHALL PROVIDE ADEQUATE MEANS TO PREVENT DAMAGE TO ADJACENT STRUCTURES.
2. OVERLOOK LAYOUT SHALL BE PROVIDED AND MAINTAINED BY THE CONTRACTOR. AS THE LAYOUT IS DEPENDENT ON WORK COMPLETED IN PHASE 1, CONFIRM ALIGNMENT, ELEVATIONS AND DISTANCES AND NOTIFY THE OWNER IF ADJUSTMENTS ARE NEEDED.

PHASE 2 NOTES:

1. THE PHASE 1 TEMPORARY FENCE ALONG THE SEAWALL CAP SHALL REMAIN IN PLACE UNTIL OVERLOOK CONSTRUCTION IS COMPLETED. UPON APPROVAL OF THE CITY, NEATLY REMOVE AND PACKAGE THE TEMPORARY FENCE, INCLUDING DELIVERY TO THE CITY STORAGE YARD ON CONSTITUTION AVE. INSTALL THE STOCKPILED GRANITE PAVERS ALONG THE SEAWALL CAP, FLUSH WITH ADJACENT PAVERS AND THE TIMBER OVERLOOK DECK.
2. A SEATING BLOCK FROM PHASE 1 ADJACENT TO THE FENCE WAS TEMPORARILY REMOVED AND IS IN CITY STORAGE - RESET IN ORIGINAL LOCATION ON GROUT.

PLAN REF. NOTES:

1. HARBORWALK PARK, DANIEL STREET AT MEMORIAL BRIDGE, SEPT. 5, 2013, WATERFRONT ENGINEERS ET. AL.
2. HARBORWALK PARK, DANIEL STREET AT MEMORIAL BRIDGE, AS-BUILT DRAWINGS, 9-16-14, ARCHER-WESTERN CONTRACTORS.

WATERFRONT ENGINEERS LLC

3 Linda Lane
Stratham, New Hampshire
(603) 772-3706
www.waterfrontengineers.com

No.	Description	Apprv.	Date
1	ISSUED FOR CONSTRUCTION	DCM	2-12-15

DRAWING REVISIONS



Date: 02/12/15
Scale: As Shown
Designer: DCM
Approved by: DCM
Project No:
File:

HARBORWALK PARK

DANIEL STREET AT
MEMORIAL BRIDGE



CITY OF PORTSMOUTH
DEPARTMENT OF PUBLIC WORKS
680 Peverly Hill Road

WATERFRONT ENGINEERS LLC

3 Linda Lane
Stratham, New Hampshire
(603) 772-3706
www.waterfrontengineers.com

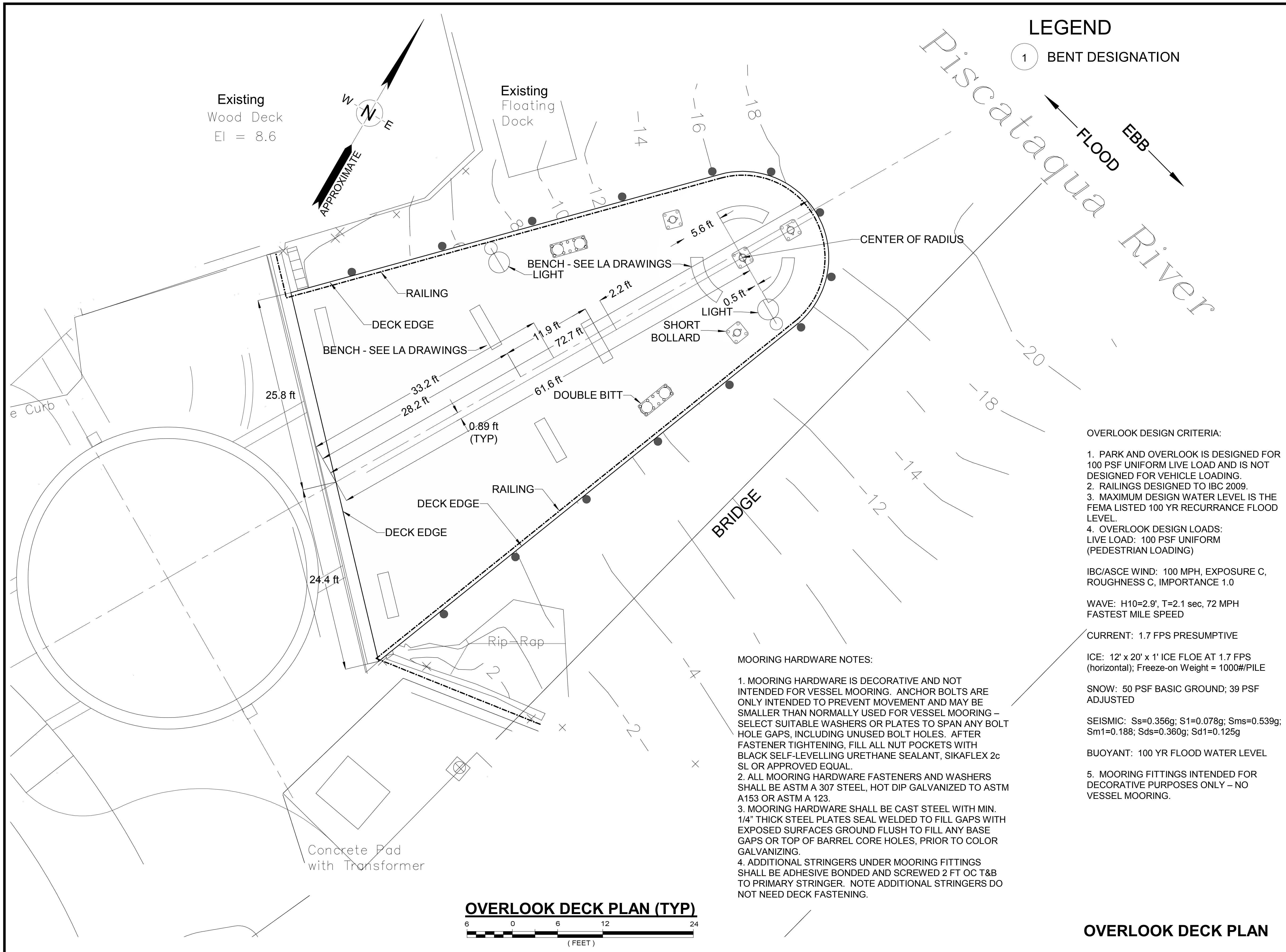

LEGEND

① BENT DESIGNATION

WATERFRONT ENGINEERS LLC

3 Linda Lane
 Stratham, New Hampshire
 (603) 772-3706
 www.waterfrontengineers.com

No.	Description	Apprv.	Date
1	ISSUED FOR CONSTRUCTION	DCM	2-12-15

DRAWING REVISIONS

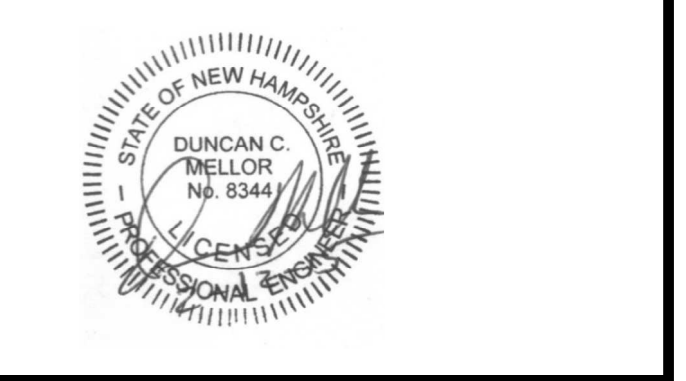

Date: 02/12/15
 Scale: As Shown
 Designer: DCM
 Approved by: DCM
 Project No:
 File:

HARBORWALK PARK

DANIEL STREET AT
 MEMORIAL BRIDGE



CITY OF PORTSMOUTH
 DEPARTMENT OF PUBLIC WORKS
 680 Peverly Hill Road

OVERLOOK DESIGN CRITERIA:

1. PARK AND OVERLOOK IS DESIGNED FOR 100 PSF UNIFORM LIVE LOAD AND IS NOT DESIGNED FOR VEHICLE LOADING.
2. RAILINGS DESIGNED TO IBC 2009.
3. MAXIMUM DESIGN WATER LEVEL IS THE FEMA LISTED 100 YR RECURRANCE FLOOD LEVEL.
4. OVERLOOK DESIGN LOADS:
 LIVE LOAD: 100 PSF UNIFORM (PEDESTRIAN LOADING)

IBC/ASCE WIND: 100 MPH, EXPOSURE C,
 ROUGHNESS C, IMPORTANCE 1.0

WAVE: H10=2.9', T=2.1 sec, 72 MPH
 FASTEST MILE SPEED

CURRENT: 1.7 FPS PRESUMPTIVE

ICE: 12' x 20' x 1' ICE FLOE AT 1.7 FPS
 (horizontal); Freeze-on Weight = 1000#/PILE

SNOW: 50 PSF BASIC GROUND; 39 PSF
 ADJUSTED

SEISMIC: Ss=0.356g; S1=0.078g; Sms=0.539g;
 Sm1=0.188; Sds=0.360g; Sd1=0.125g

BUOYANT: 100 YR FLOOD WATER LEVEL

5. MOORING FITTINGS INTENDED FOR DECORATIVE PURPOSES ONLY – NO VESSEL MOORING.

MOORING HARDWARE NOTES:

1. MOORING HARDWARE IS DECORATIVE AND NOT INTENDED FOR VESSEL MOORING. ANCHOR BOLTS ARE ONLY INTENDED TO PREVENT MOVEMENT AND MAY BE SMALLER THAN NORMALLY USED FOR VESSEL MOORING – SELECT SUITABLE WASHERS OR PLATES TO SPAN ANY BOLT HOLE GAPS, INCLUDING UNUSED BOLT HOLES. AFTER FASTENER TIGHTENING, FILL ALL NUT POCKETS WITH BLACK SELF-LEVELLING URETHANE SEALANT, SIKAFLEX 2c SL OR APPROVED EQUAL.
2. ALL MOORING HARDWARE FASTENERS AND WASHERS SHALL BE ASTM A 307 STEEL, HOT DIP GALVANIZED TO ASTM A153 OR ASTM A 123.
3. MOORING HARDWARE SHALL BE CAST STEEL WITH MIN. 1/4" THICK STEEL PLATES SEAL WELDED TO FILL GAPS WITH EXPOSED SURFACES GROUND FLUSH TO FILL ANY BASE GAPS OR TOP OF BARREL CORE HOLES, PRIOR TO COLOR GALVANIZING.
4. ADDITIONAL STRINGERS UNDER MOORING FITTINGS SHALL BE ADHESIVE BONDED AND SCREWED 2 FT OC T&B TO PRIMARY STRINGER. NOTE ADDITIONAL STRINGERS DO NOT NEED DECK FASTENING.

OVERLOOK DECK PLAN (TYP)



OVERLOOK DECK PLAN

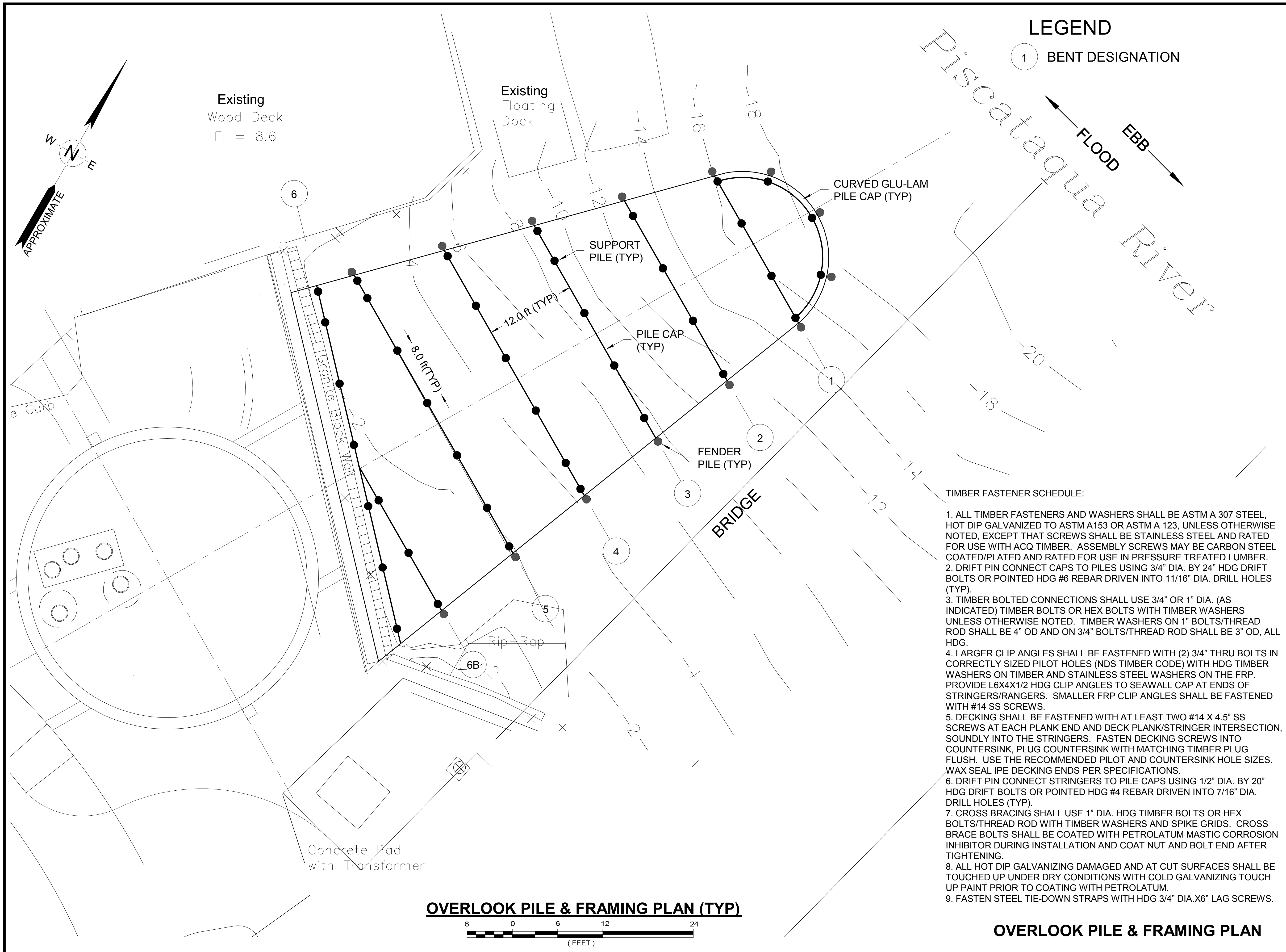

LEGEND

① BENT DESIGNATION

Piscataqua River

FLOOD EBB

TIMBER FASTENER SCHEDULE:

1. ALL TIMBER FASTENERS AND WASHERS SHALL BE ASTM A 307 STEEL, HOT DIP GALVANIZED TO ASTM A153 OR ASTM A 123, UNLESS OTHERWISE NOTED, EXCEPT THAT SCREWS SHALL BE STAINLESS STEEL AND RATED FOR USE WITH ACQ TIMBER. ASSEMBLY SCREWS MAY BE CARBON STEEL COATED/PLATED AND RATED FOR USE IN PRESSURE TREATED LUMBER.
2. DRIFT PIN CONNECT CAPS TO PILES USING 3/4" DIA. BY 24" HDG DRIFT BOLTS OR POINTED HDG #6 REBAR DRIVEN INTO 11/16" DIA. DRILL HOLES (TYP).
3. TIMBER BOLTED CONNECTIONS SHALL USE 3/4" OR 1" DIA. (AS INDICATED) TIMBER BOLTS OR HEX BOLTS WITH TIMBER WASHERS UNLESS OTHERWISE NOTED. TIMBER WASHERS ON 1" BOLTS/THREAD ROD SHALL BE 4" OD AND ON 3/4" BOLTS/THREAD ROD SHALL BE 3" OD, ALL HDG.
4. LARGER CLIP ANGLES SHALL BE FASTENED WITH (2) 3/4" THRU BOLTS IN CORRECTLY SIZED PILOT HOLES (NDS TIMBER CODE) WITH HDG TIMBER WASHERS ON TIMBER AND STAINLESS STEEL WASHERS ON THE FRP. PROVIDE L6X4X1/2 HDG CLIP ANGLES TO SEAWALL CAP AT ENDS OF STRINGERS/RANGERS. SMALLER FRP CLIP ANGLES SHALL BE FASTENED WITH #14 SS SCREWS.
5. DECKING SHALL BE FASTENED WITH AT LEAST TWO #14 X 4.5" SS SCREWS AT EACH PLANK END AND DECK PLANK/STRINGER INTERSECTION. SOUNDLY INTO THE STRINGERS. FASTEN DECKING SCREWS INTO COUNTERSINK, PLUG COUNTERSINK WITH MATCHING TIMBER PLUG FLUSH. USE THE RECOMMENDED PILOT AND COUNTERSINK HOLE SIZES. WAX SEAL IPE DECKING ENDS PER SPECIFICATIONS.
6. DRIFT PIN CONNECT STRINGERS TO PILE CAPS USING 1/2" DIA. BY 20" HDG DRIFT BOLTS OR POINTED HDG #4 REBAR DRIVEN INTO 7/16" DIA. DRILL HOLES (TYP).
7. CROSS BRACING SHALL USE 1" DIA. HDG TIMBER BOLTS OR HEX BOLTS/THREAD ROD WITH TIMBER WASHERS AND SPIKE GRIDS. CROSS BRACE BOLTS SHALL BE COATED WITH PETROLATUM MASTIC CORROSION INHIBITOR DURING INSTALLATION AND COAT NUT AND BOLT END AFTER TIGHTENING.
8. ALL HOT DIP GALVANIZING DAMAGED AND AT CUT SURFACES SHALL BE TOUCHED UP UNDER DRY CONDITIONS WITH COLD GALVANIZING TOUCH UP PAINT PRIOR TO COATING WITH PETROLATUM.
9. FASTEN STEEL TIE-DOWN STRAPS WITH HDG 3/4" DIA. X6" LAG SCREWS.

OVERLOOK PILE & FRAMING PLAN (TYP)



OVERLOOK PILE & FRAMING PLAN

WATERFRONT ENGINEERS LLC
 3 Linda Lane
 Stratham, New Hampshire
 (603) 772-3706
 www.waterfrontengineers.com

No.	Description	Apprv.	Date
1	ISSUED FOR CONSTRUCTION	DCM	2-12-15

DRAWING REVISIONS

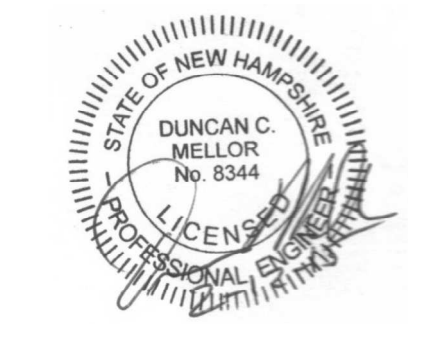

Date: 02/12/15
 Scale: As Shown
 Designer: DCM
 Approved by: DCM
 Project No:
 File:

HARBORWALK PARK

DANIEL STREET AT
 MEMORIAL BRIDGE



CITY OF PORTSMOUTH
 DEPARTMENT OF PUBLIC WORKS
 680 Peverly Hill Road

WATERFRONT ENGINEERS LLC
 3 Linda Lane
 Stratham, New Hampshire
 (603) 772-3706
 www.waterfrontengineers.com

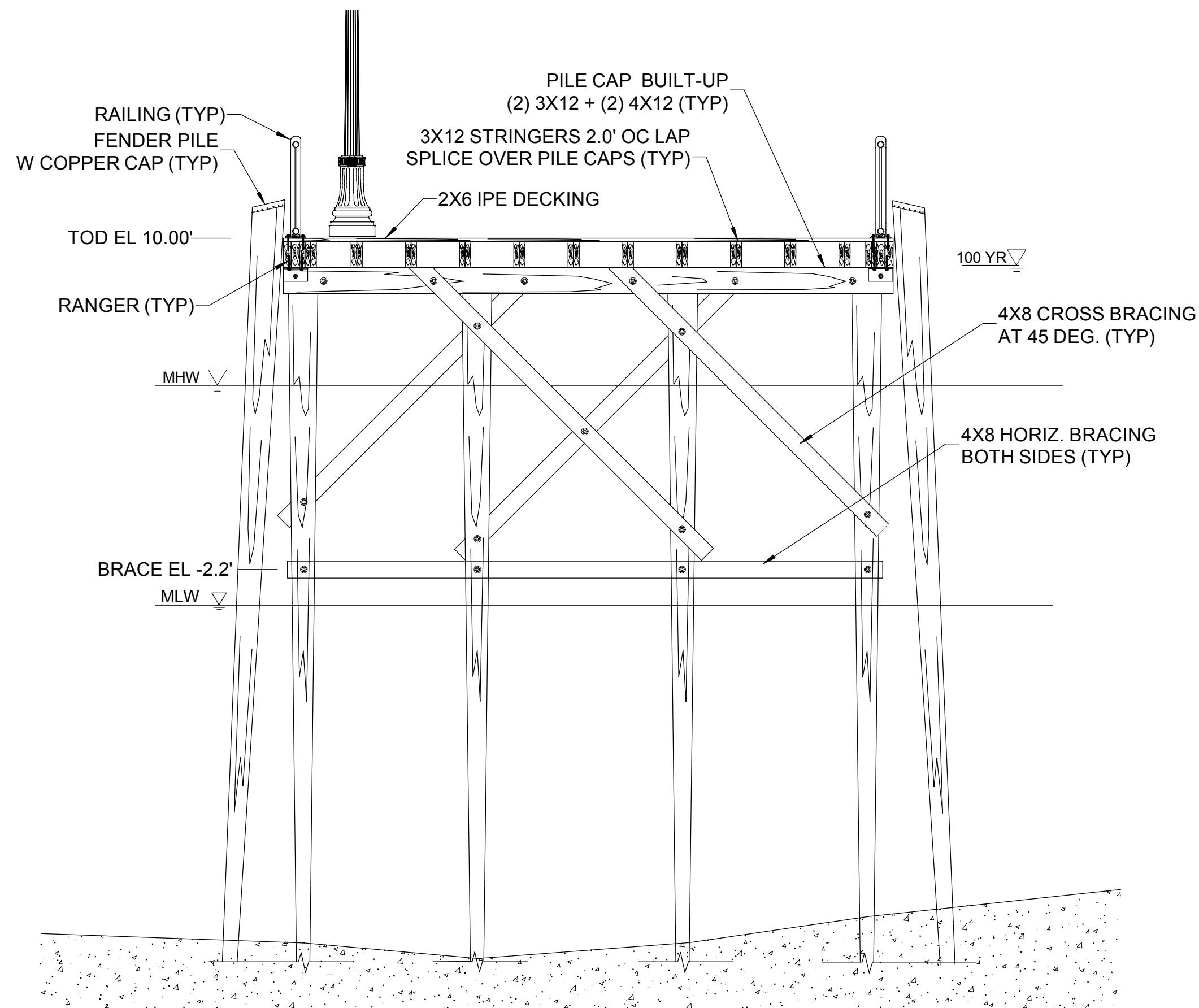

BENT 1 CROSS SECTION (TYP)
BENT 2 SIMILAR

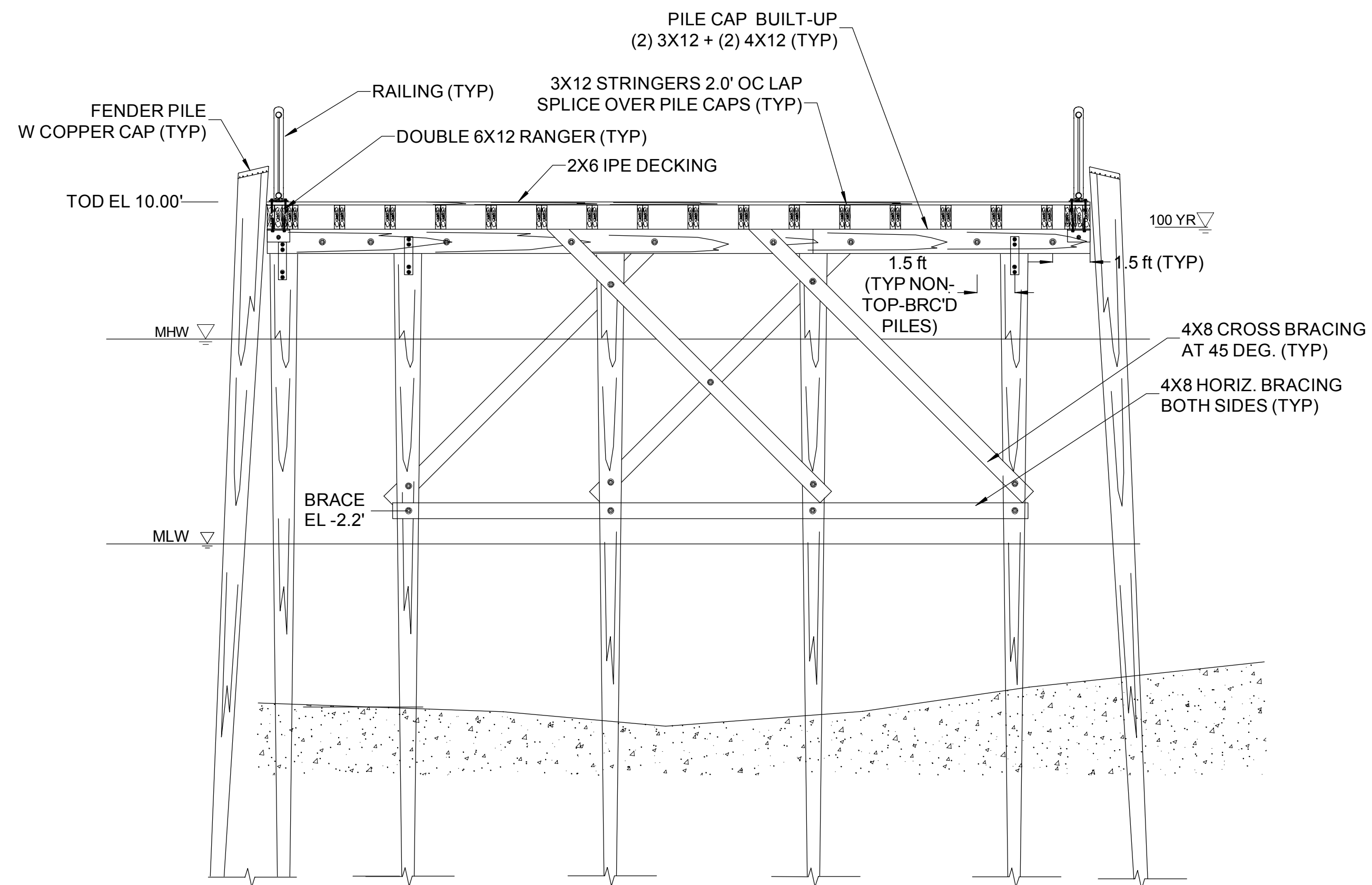

BENT 3 CROSS SECTION (TYP)
BENT 4 SIMILAR

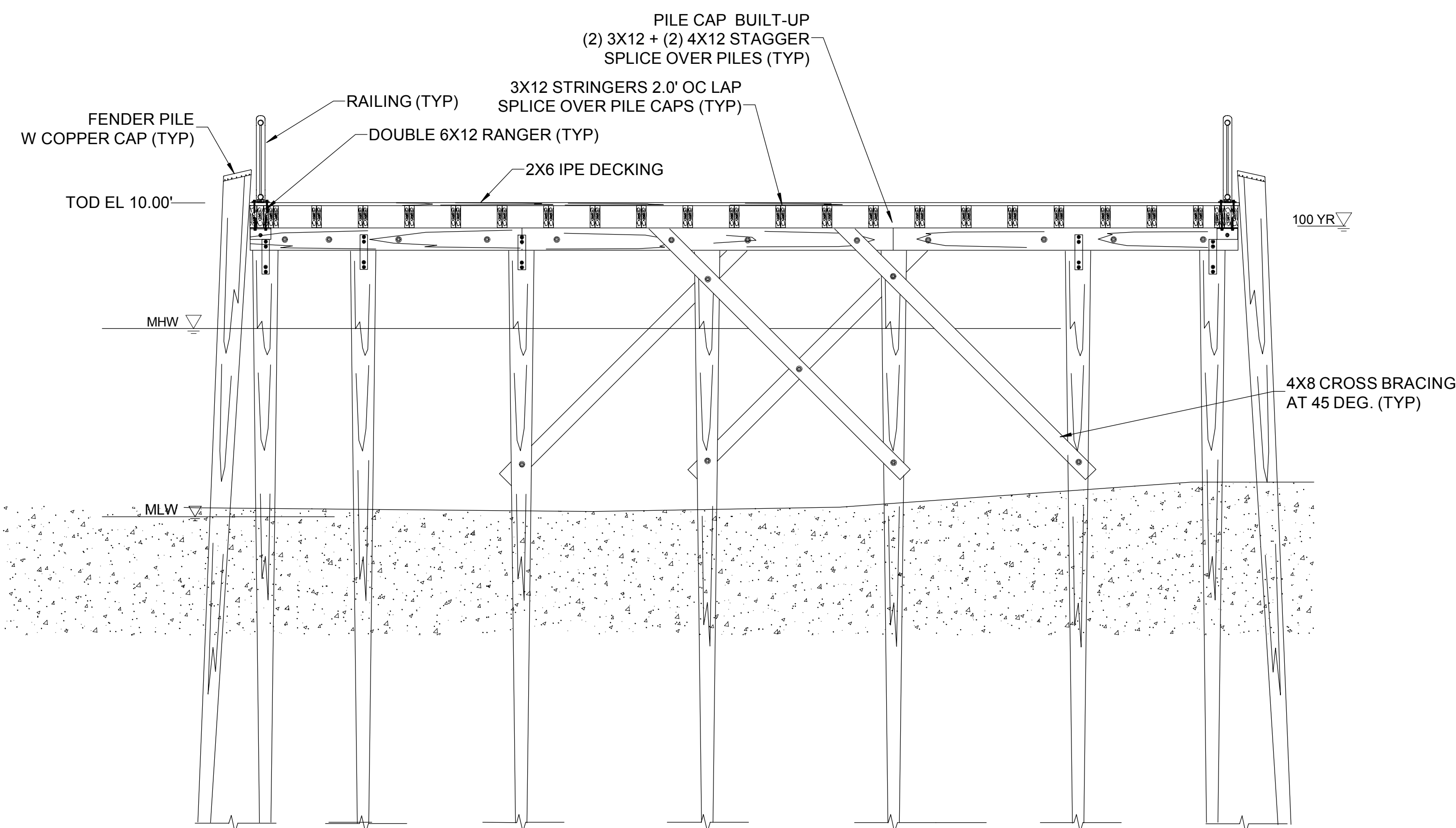

BENT 5 CROSS SECTION (TYP)
BENT 6 SIMILAR, EXCEPT NO CROSS BRACING

TIMBER-WORK NOTES:

1. TIMBER NOT OTHERWISE SPECIFIED SHALL BE NO. 2 DENSE OR BETTER SOUTHERN YELLOW PINE TREATED WITH CCA TO 2.5 PCF RETENTION. FIELD COAT CUT ENDS (DRY) AND DRILL HOLES ABOVE MEAN HIGH WATER WITH COPPER NAPHTHENE PRESERVATIVE IN ACCORDANCE WITH TREATMENT MANUFACTURERS INSTRUCTIONS.
2. SUPERSTRUCTURE DIMENSION TIMBER SHALL BE NO. 2 DENSE OR BETTER SOUTHERN YELLOW PINE TREATED WITH CCA TO 2.5 PCF RETENTION, UNLESS OTHERWISE NOTED. THE 2X6 DECKING SHALL BE S4S FIRST QUALITY ONE FACE GRADE OR BETTER. THE 3X12 AND 4X12 IN CAPS, STRINGERS & RANGERS SHALL BE S4S NO. 2 DENSE OR BETTER SOUTHERN YELLOW PINE TREATED WITH CCA TO 2.5 PCF RETENTION.
3. BRACING TIMBERS SHALL BE FULL DIMENSION ROUGH SAWN. ALL BRACING CONNECTIONS SHALL USE 1" DIA. BOLTS AND APPROPRIATE SPIKE GRIDS (CURVED/FLAT OR FLAT/FLAT).
4. CROSS BRACE BLOCKING AND SHIMS SHALL BE COMPOSITE/PLASTIC LUMBER, OR HDPE PLASTIC. TAPERED GAPS AT PILE HEADS SHALL BE FILLED WITH DRIVE FIT TAPERED PLASTIC SHIMS FOR FULL BEARING, PARALLEL GAPS SHALL BE FILLED TIGHT WITH FLAT HDPE PLATE/SHIM STOCK; OR PL400/ EQUAL CONSTRUCTION ADHESIVE TO PROVIDE FULL BEARING.
5. SUPPORT PILES SHALL BE ASTM D25 CLASS B SOUTHERN YELLOW PINE TREATED WITH CCA TO 2.5 PCF RETENTION DRIVEN TO AT LEAST 10 TON ALLOWABLE CAPACITY. BASE BIDS ON 40' LONG SUPPORT PILES. THE CONTRACTOR SHALL DRIVE TEST PILES AT EACH END AND MID PIER LENGTH AS TEST PILES TO VERIFY SUBSURFACE CONDITIONS FOR ORDERING THE PRODUCTION PILES.
6. FENDER TIMBER PILES SHALL BE ASTM D25 8 INCH TIP NATURAL TAPER SOUTHERN YELLOW PINE TREATED WITH CCA TO 2.5 PCF RETENTION DRIVEN TO PRACTICAL REFUSAL WITH A PILE HAMMER. BASE BIDS ON 35' LONG FENDER PILES.
7. OUTER SIDE OF RANGERS, GLUE-LAM BEAMS AND PILE CAP ENDS (VISIBLE) SHALL BE STAINED UPON ADEQUATE DRYING WITH CABOT 1400 SERIES SEMI-SOLID STAIN, BEECHWOOD GRAY, OR APPROVED EQUAL, IN ACCORDANCE WITH MANUFACTURER'S RECOMMENDATIONS.
8. BUILT-UP PILE CAPS AND RANGERS SHALL USE A CONTINUOUS 3/16" BEAD OF CONSTRUCTION ADHESIVE 2" FROM THE TOP AND BOTTOM ON MEETING FACES AND BUTT END SURFACES DURING ASSEMBLY. ADHESIVE SHALL BE SUITABLE FOR WET PRESSURE TREATED WOOD BONDING, SUCH AS LOCTITE PL400, OR APPROVED EQUAL.
9. ALL STRINGER, RANGER, GLUE-LAMS AND PILE CAP TOPS SHALL BE COVERED WITH WATERPROOFING MEMBRANE WITH 3/4" EDGE OVERHANGS.
10. TIMBER SEAT ON SEAWALL CAP TO BE 12-BY LUMBER WITH THICKNESS TO SUIT FINISH DECK ELEVATION, PROVIDE 3/4" ANCHOR BOLTS AT 4' OC. 4 X 12 TIMBER ALONG SEAWALL SEAT FACE SHALL BE PRECISELY SET TO MATCH TOPS OF ADJACENT STRINGERS AND SHALL BE USED TO SECURE DIAGONAL CUT DECKING ENDS WITH 3 SCREWS PER PLANK.
11. ALL TIMBER FASTENERS, STEEL STRAPS, STEEL PLATES, ETC. SHALL BE HOT DIP GALVANIZED (EXCEPT STAINLESS STEEL). PILE TO CAP TIE STRAPS SHALL BE ADH-19 4"x18" HURRICANE STRAPS BY ACE MARINE, OR APPROVED EQUAL.

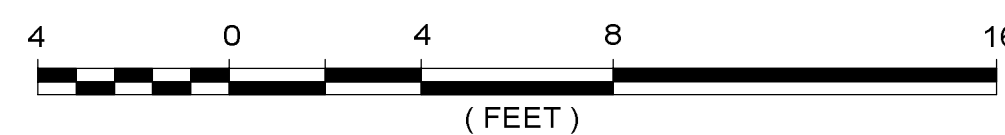

OVERLOOK SECTIONS

WATERFRONT ENGINEERS LLC

3 Linda Lane
Stratham, New Hampshire
(603) 772-3706
www.waterfrontengineers.com

No.	Description	Apprv.	Date
1	ISSUED FOR CONSTRUCTION	DCM	2-12-15

DRAWING REVISIONS

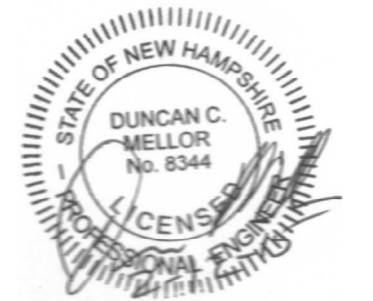

Date: 02/12/15
Scale: As Shown
Designer: DCM
Approved by: DCM
Project No:
File:

HARBORWALK PARK

DANIEL STREET AT
MEMORIAL BRIDGE



CITY OF PORTSMOUTH

DEPARTMENT OF PUBLIC WORKS
680 Peverly Hill Road

WATERFRONT ENGINEERS LLC

3 Linda Lane
Stratham, New Hampshire
(603) 772-3706
www.waterfrontengineers.com

FENDER PILE CAP NOTES:

- FENDER PILES SHALL BE CAPPED WITH A WATERTIGHT MALEABLE COPPER SHEET (16 OZ/SF) CAP NEATLY BENT AND FOLDED TO EXTEND 1.5" OVER THE EDGES AND BE SECURED WITH COPPER NAILS 2" ON CENTER AROUND THE PERIMETER.

WATERFRONT ENGINEERS LLC

3 Linda Lane
Stratham, New Hampshire
(603) 772-3706
www.waterfrontengineers.com

No.	Description	Apprv.	Date
1	ISSUED FOR CONSTRUCTION	DCM	2-12-15

DRAWING REVISIONS



Date: 02/12/15
Scale: As Shown
Designer: DCM
Approved by: DCM
Project No:
File:

HARBORWALK PARK

DANIEL STREET AT
MEMORIAL BRIDGE



CITY OF PORTSMOUTH
DEPARTMENT OF PUBLIC WORKS
680 Peverly Hill Road

WATERFRONT ENGINEERS LLC

3 Linda Lane
Stratham, New Hampshire
(603) 772-3706
www.waterfrontengineers.com

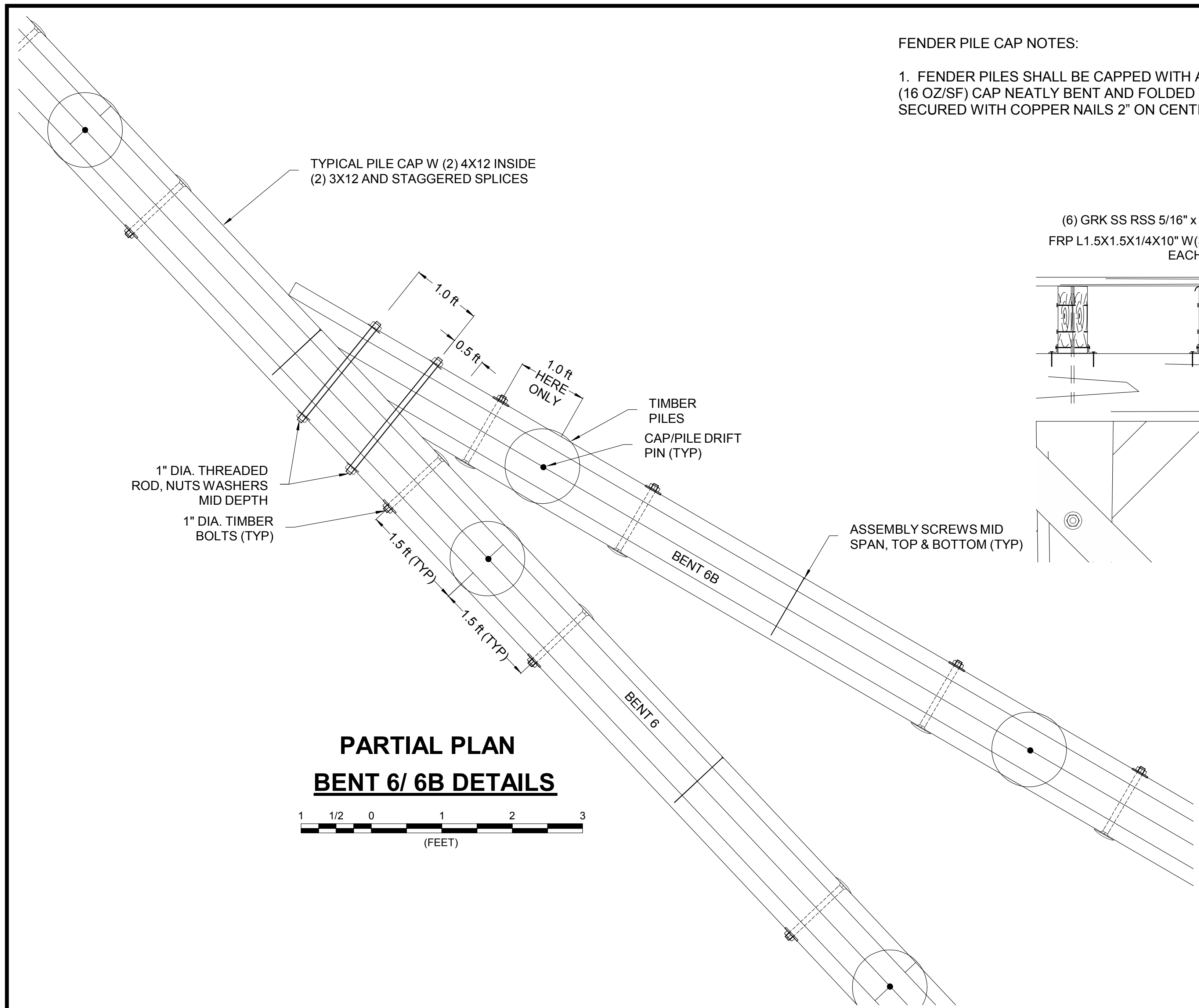

**PARTIAL PLAN
BENT 6/ 6B DETAILS**

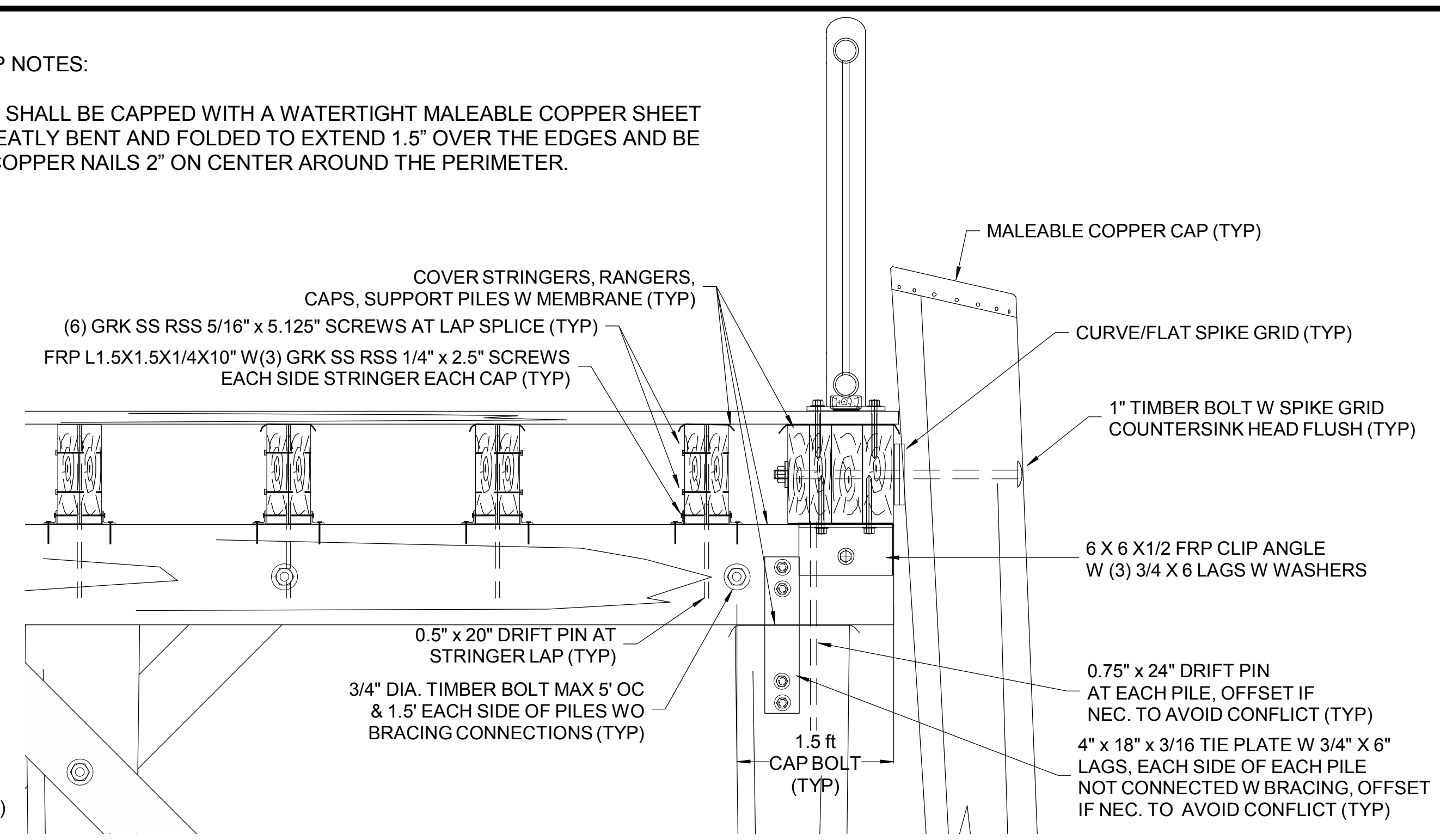
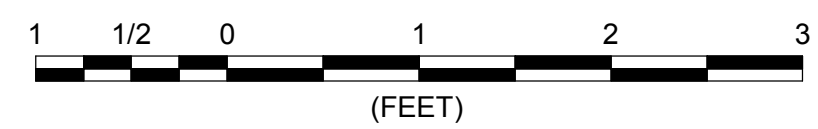

CONNECTIONS DETAILS (TYP)

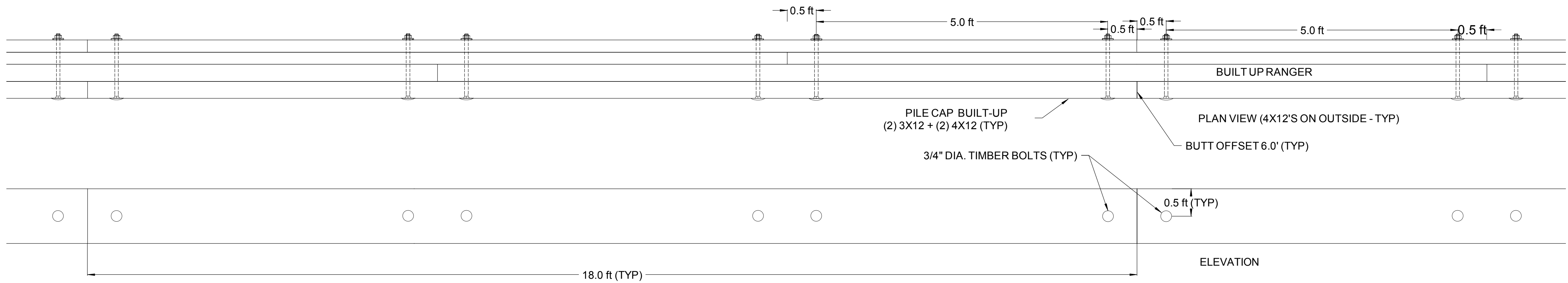
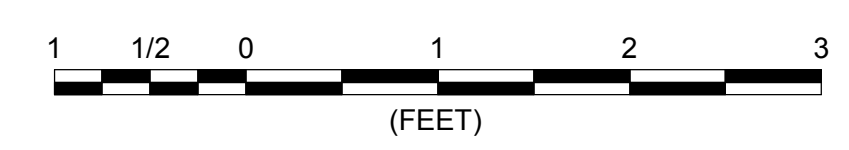

RANGER DETAILS (TYP)

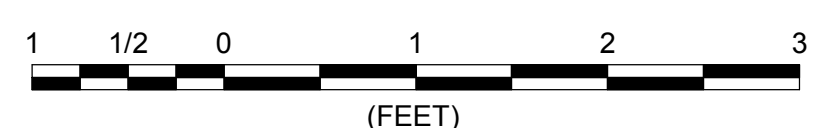

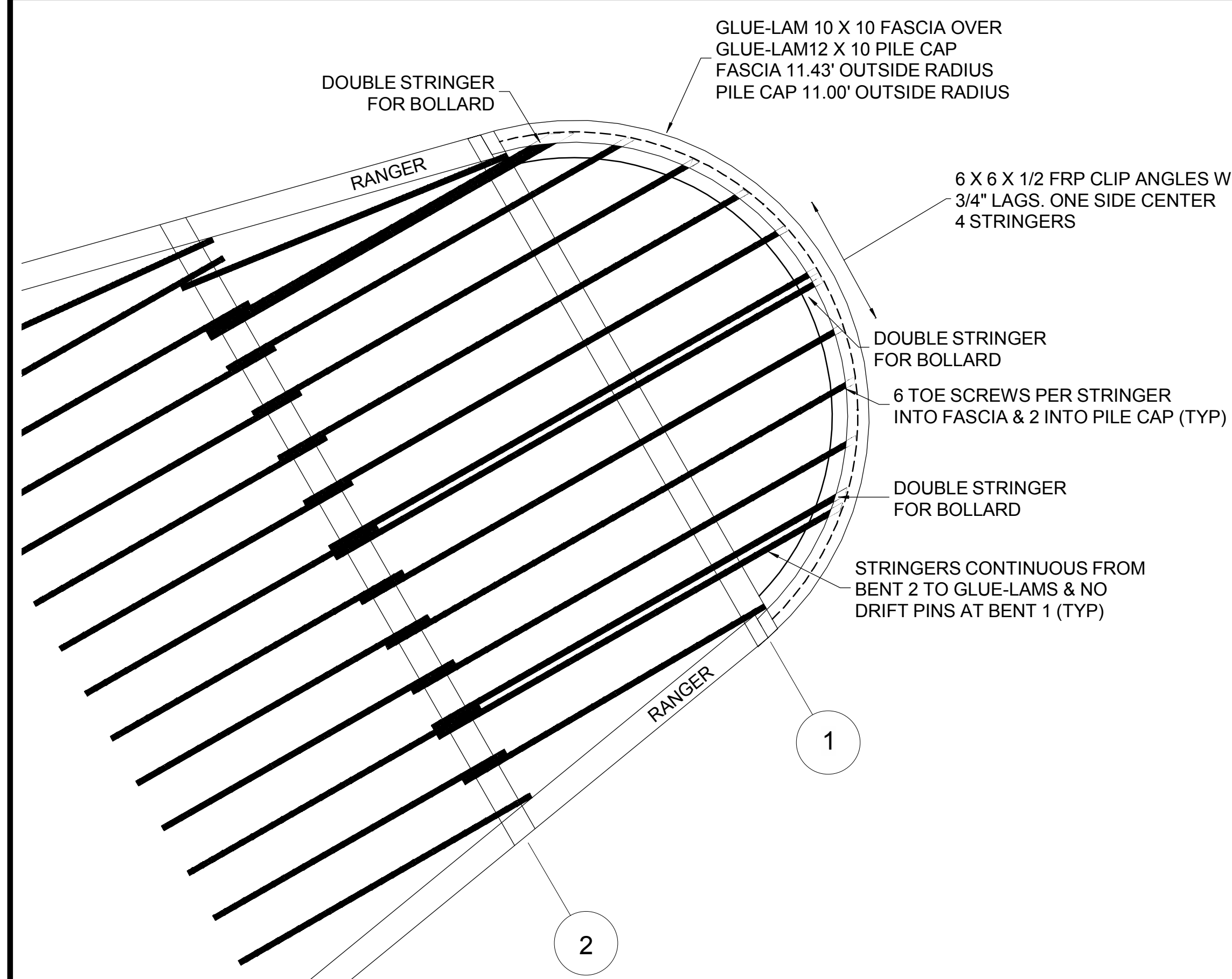

**PLAN
OVERLOOK END FRAMING**

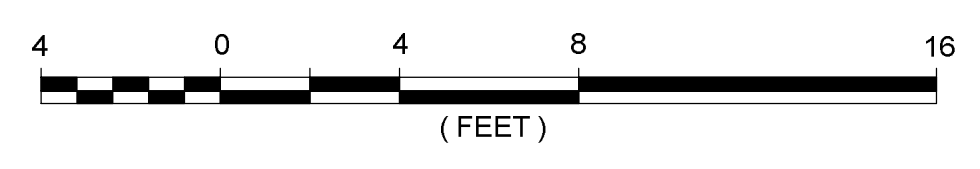

END DRIFT PIN NOTES:

1. PILES UNDER THE CURVED PILE CAP SHALL HAVE THE SAME DRIFT PIN AND TIE PLATE CONNECTIONS AS THE STRAIGHT PILE CAPS.
2. CONNECT CURVED FASCIA TO CURVED PILE CAP BELOW WITH FOUR EQUALLY SPACED VERTICAL DRIFT PINS (MID-WAY BETWEEN PILES).

RAILING NOTES:

1. FABRICATE THE RAILINGS AS SHOWN. EASE ALL EXPOSED EDGES AND GRIND SMOOTH WELDS (GRIND FLUSH AT GROOVE WELDS) PRIOR TO COATING. IF 3/4" RODS ARE SET INTO RAIL HOLES, THEN SEAL WELD ALL AROUND. IF 3/4" RODS ARE BUTTED UP TO RAILS, THEN 1/4" FILLET WELD ALL AROUND.
2. ANCHOR BOLTS IN TIMBER: (4) 5/8" DIA. X 6" LONG MIN. HDG LAG BOLTS WITH STAINLESS STEEL WASHER.
3. ANCHOR BOLTS AT SEAWALL: EPOXY RESIN BEDDED (4) 5/8" DIA. STAINLESS STEEL THREADED ROD, SS WASHER, SS NUT. WHEN SET ON PAVERS PROVIDE FULL CAPACITY DEVELOPMENT IN THE CONCRETE BELOW THE PAVERS (TYP).
4. PLUMB POSTS, SET RAIL PANELS AND GROUT UNDER BASE PLATES (TYP).
5. FOR HOT DIP GALVANIZED COLOR GALV COATING (BLACK), PROVIDE ADEQUATE VENTING OF PIPES WHERE HIDDEN FROM VIEW AND SO AS NOT TO TRAP OR HOLD WATER. OVERLOOK END RAILING SHALL HAVE TOP AND BOTTOM PIPE RAILS BENT TO THE CORRECT RADIUS AND FABRICATED BEFORE COATING.
6. IPE TOE BOARDS SHALL BE PROVIDED BELOW THE BOTTOM RAIL AS INDICATED ON THE OVERLOOK AND SEAWALLS (TYP). ALL TOE BOARDS SHALL BE SET ON 1/8" THICK HDPE (BLACK) SHIMS UNDER EACH FASTENER. ADJUST IF NECESSARY FOR DECK OR SEAWALL IRREGULARITIES. OVERLOOK END TOE BOARDS SHALL BE CUT AND PLANED/SANDED TO THE CORRECT RADIUS FRONT AND BACK. ALL EXPOSED CUT EDGES AND ENDS SHALL BE RADIUS TO MATCH THE STANDARD DECKING EDGE RADIUS. FASTEN OVERLOOK TOE BOARDS MATCHING DECKING SCREWS (WITH COUNTERSINK & PLUGS) AT 2 FT OC MAX FRONT AND BACK. FASTEN TOE BOARDS ON SEAWALLS WITH 3/8" DIA. HDG OR SS EPOXY RESIN ANCHOR BOLTS (MIN. 3" EMBEDMENT), CENTERLINE 2 FT OC MAX, COUNTERSINK & PLUG.
7. AT SEAWALL REMOVE FOR SALVAGE THE PHASE 1 CHAIN LINK FENCE AND FILL POST HOLES WITH NON SHRINK GROUT. SET GRANITE PAVERS ON SEAWALL WITH NON SHRINK GROUT FLUSH WITH TIMBER DECK AND EXISTING PAVERS, CURE PRIOR TO INSTALLING RAILINGS. AT BRIDGE PIER OVERHANG, PROVIDE A SHORT POST AND MODIFIED RAIL PANEL, OR CANTILEVER RAIL PANEL TO FIT PIER OVERHANG, SIMILAR TO EXISTING CHAIN LINK FENCE (MAX. GAP 4").

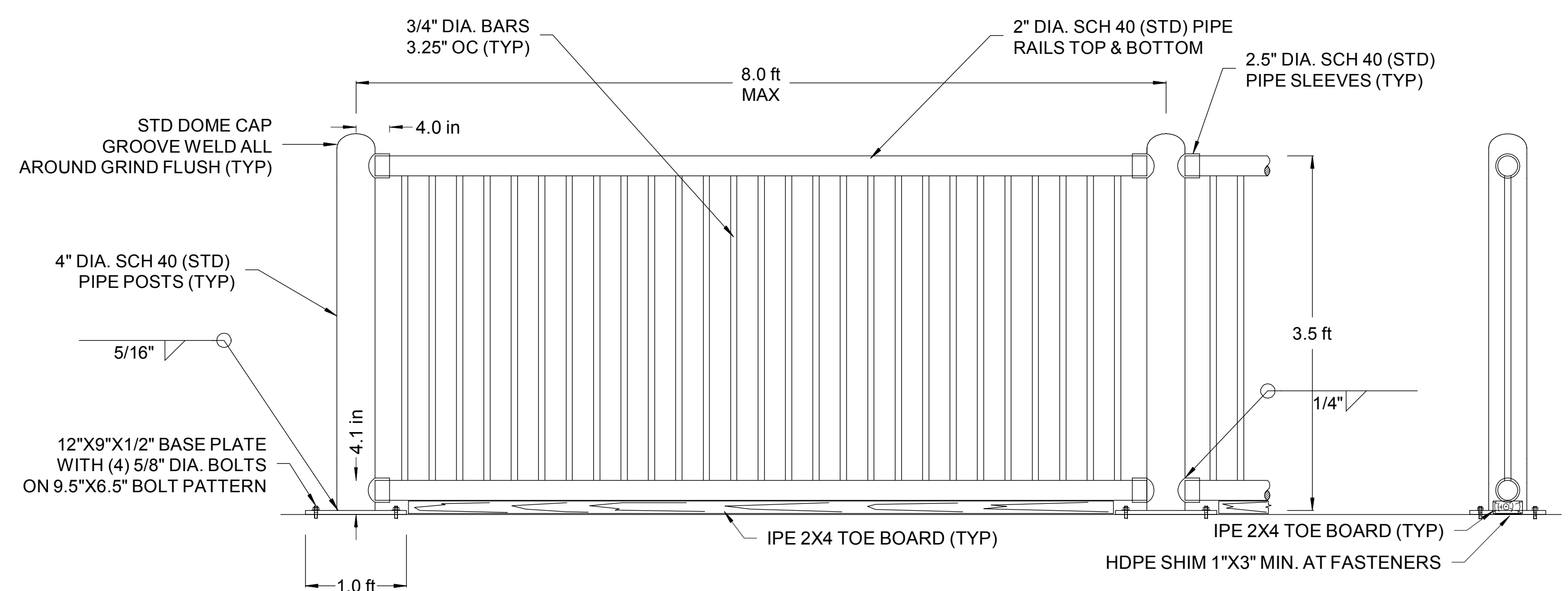

RAILING DETAILS (TYP)

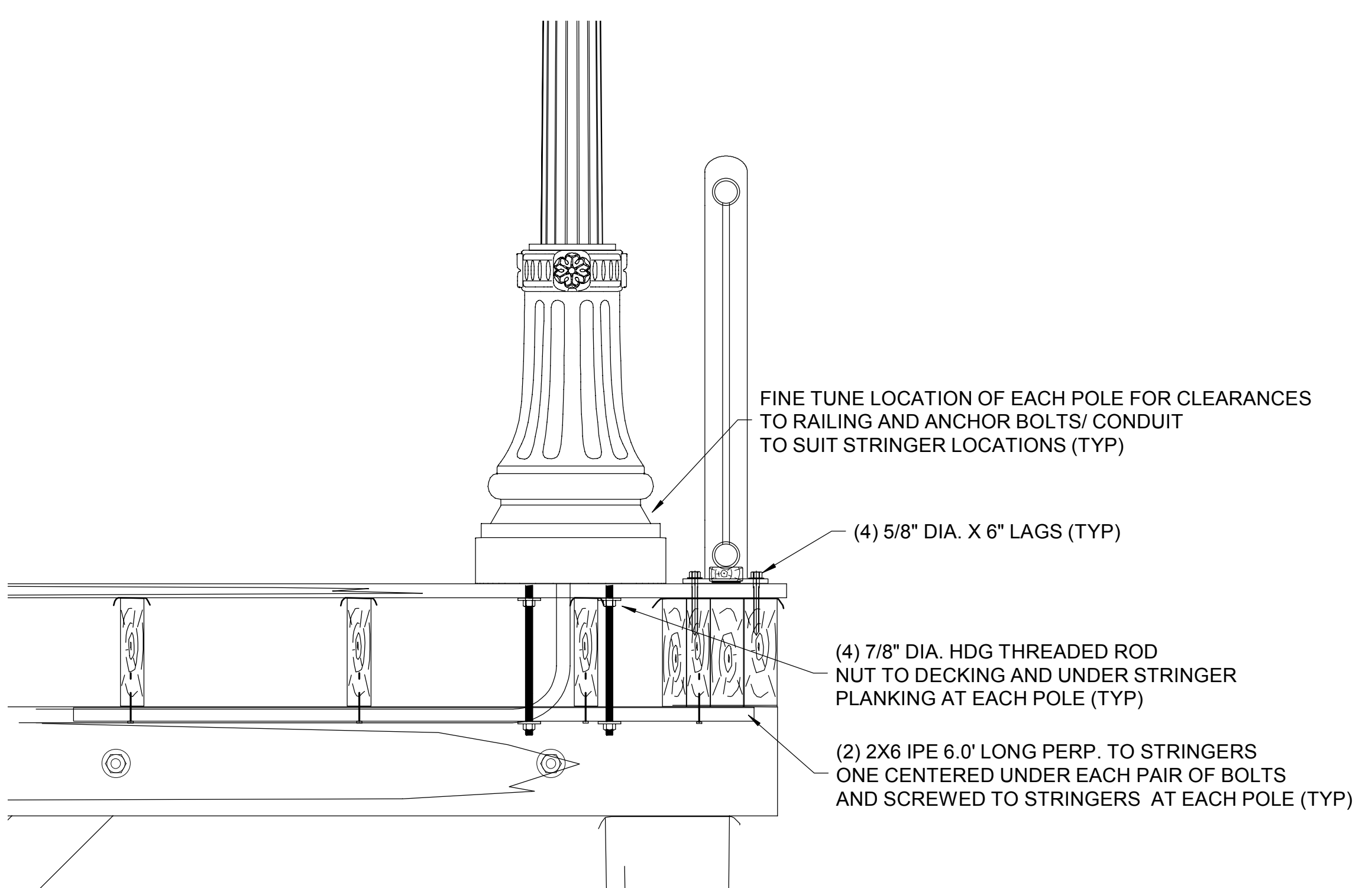
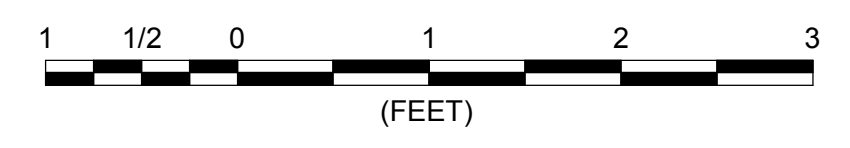

OVERLOOK POLE & RAILING DETAILS (TYP)

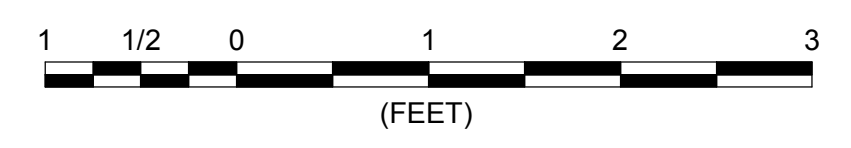

No.	Description	Apprv.	Date
1	ISSUED FOR CONSTRUCTION	DCM	2-12-15

DRAWING REVISIONS



Date: 02/12/15
 Scale: As Shown
 Designer: DCM
 Approved by: DCM
 Project No:
 File:

HARBORWALK PARK

**DANIEL STREET AT
MEMORIAL BRIDGE**



CITY OF PORTSMOUTH
 DEPARTMENT OF PUBLIC WORKS
 680 Peverly Hill Road

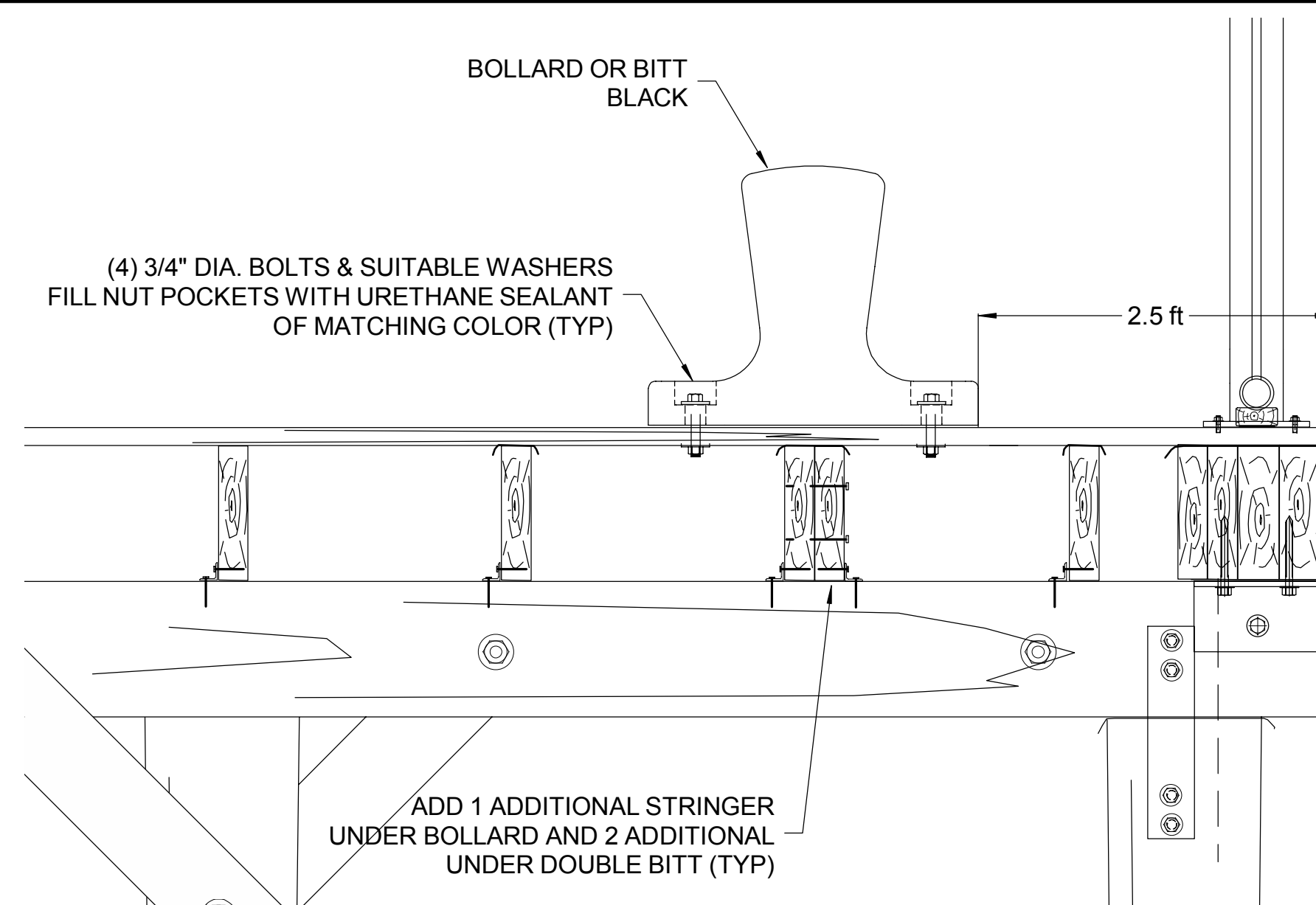

MOORING FITTING DETAILS (TYP)

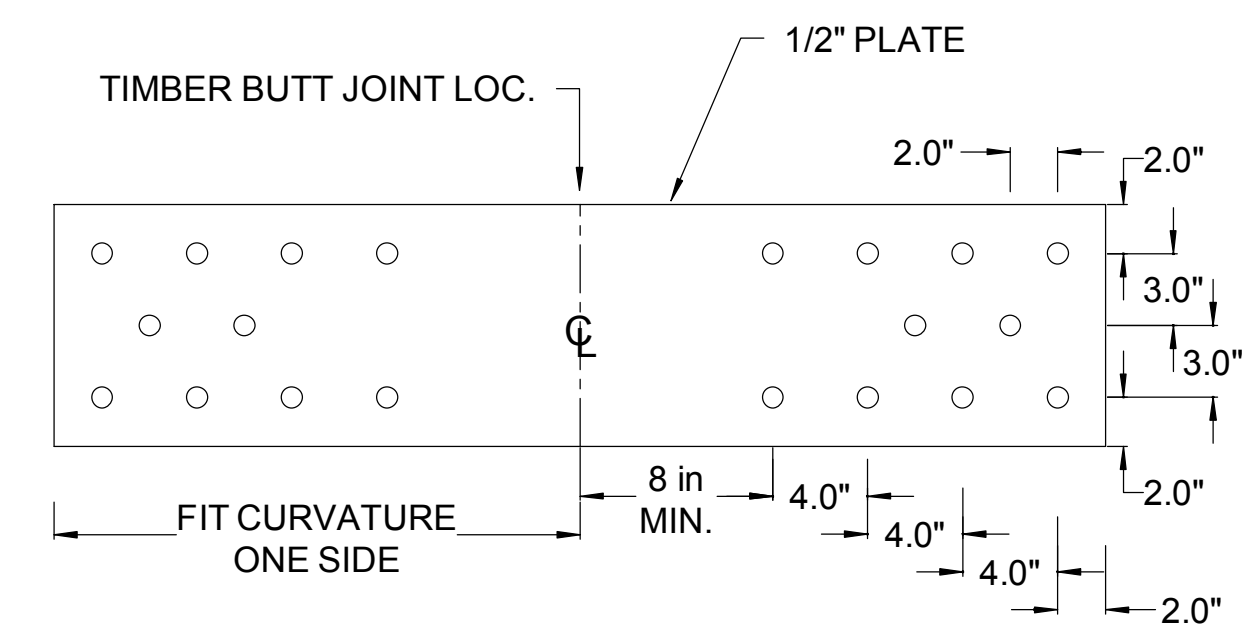
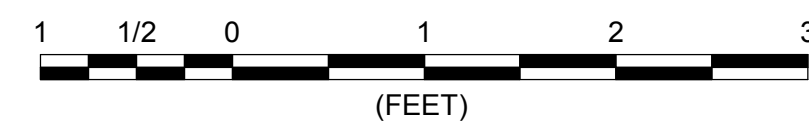

FASTEN WITH 3/4" DIA. X 6" LAGS W WASHERS

RANGER/FASCIA SPLICE PLATE "A" DETAIL (TYP)

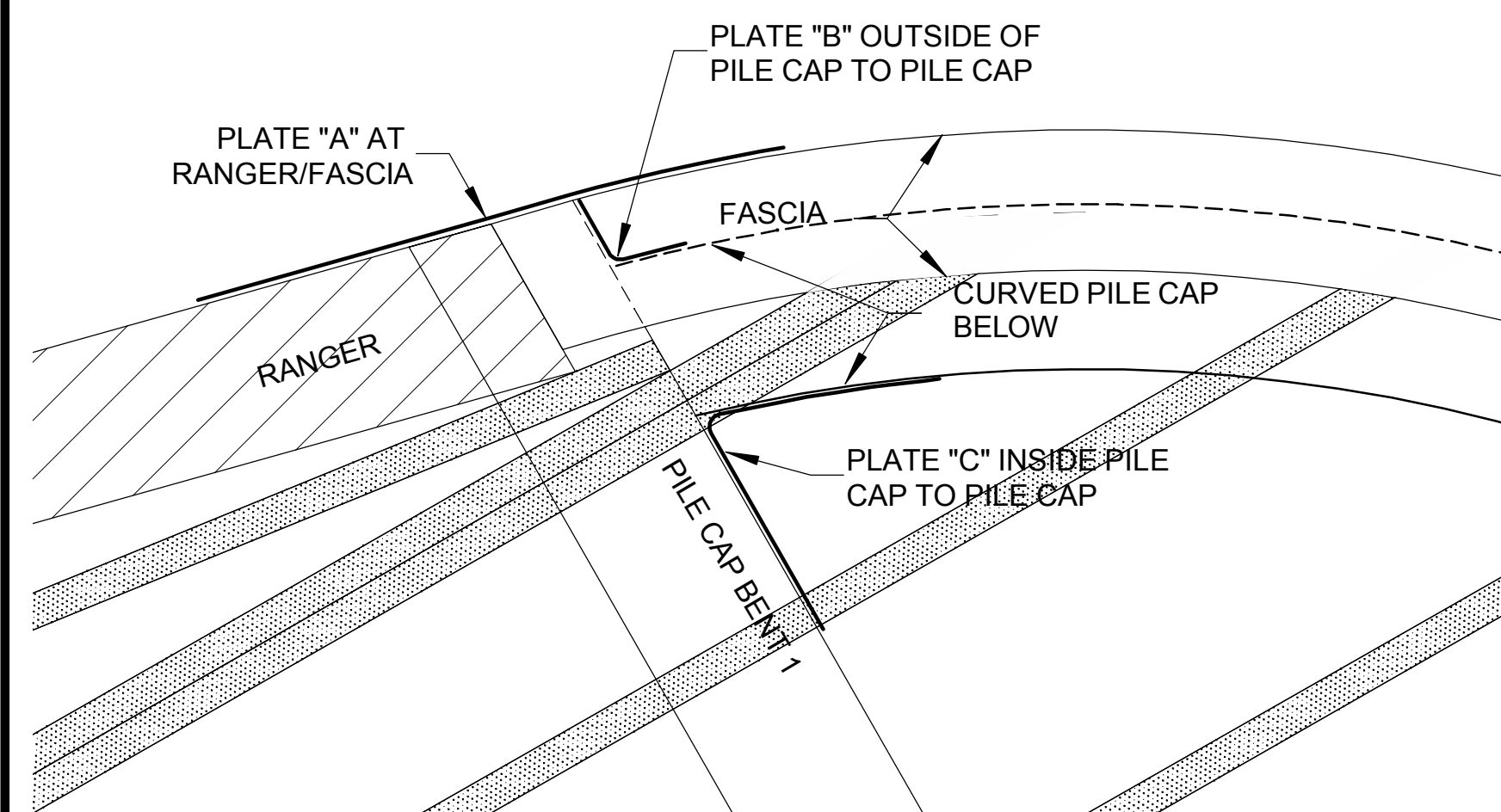
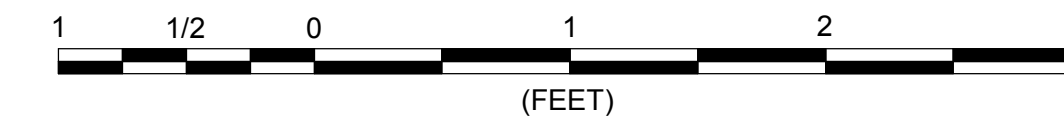

PARTIAL PLAN AT BENT 1

SPLICE PLATE LOCATIONS - BOTH ENDS BENT 1 SIMILAR

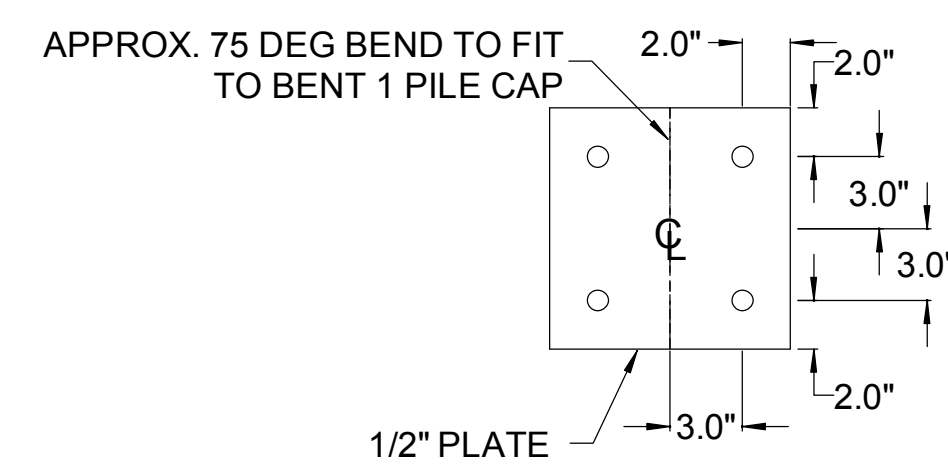
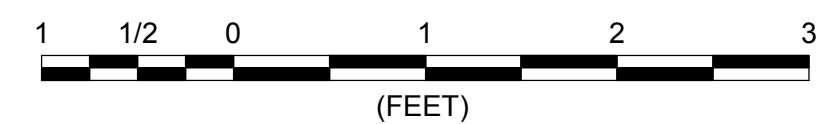

PILE CAP SPLICE PLATE "B" DETAIL (TYP)

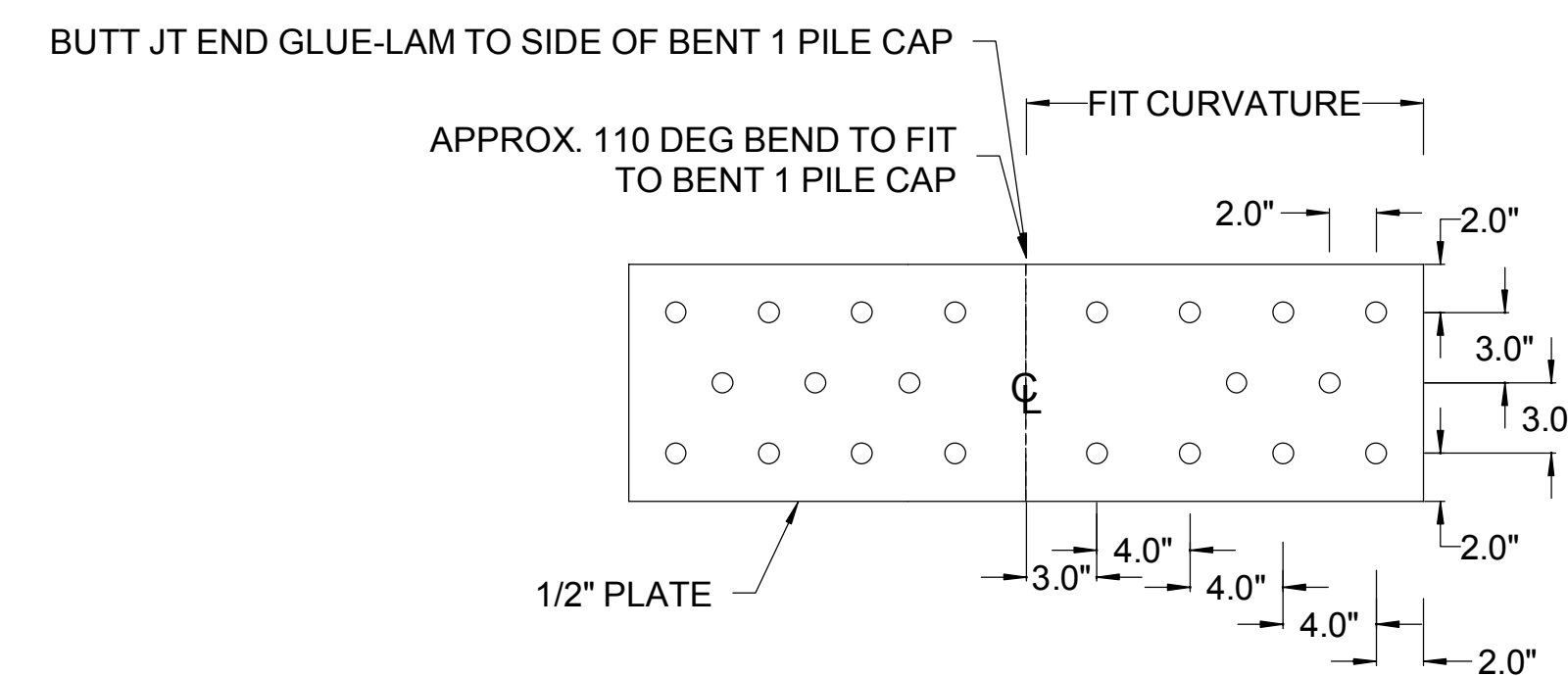
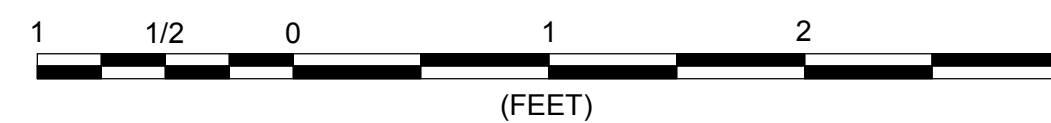

FASTEN WITH 3/4" DIA. X 6" LAGS W WASHERS

PILE CAP SPLICE PLATE "C" DETAIL (TYP)

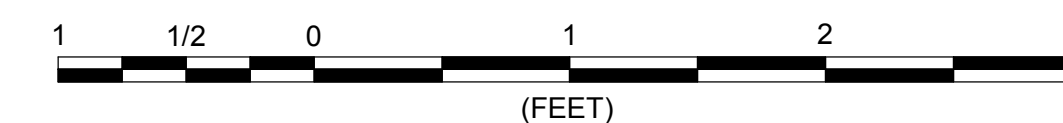

SPLICE NOTES:

1. PLATES SHOWN SHALL BE USED TO CONNECT THE GLUE-LAM FACIA (OUTER FACE) TO THE RANGERS (TOPS FLUSH) AND TO CONNECT THE GLUE-LAM PILE CAP TO THE BENT 1 PILE CAP. SPLICE PLATES SHALL BE PRE-BENT TO FIT GLUE-LAM CURVATURE AND SHALL BE BENT OR CUT AND WELDED (FULL PENETRATION WELD) TO ACCURATELY FIT BETWEEN THE GLUE-LAM PILE CAP AND THE BENT 1 PILE CAP. NOTE - PILE CUT-OFF ELEVATION UNDER GLUE-LAM IS HIGHER THAN OTHER PILES IN ORDER TO MAINTAIN CONSTANT TOP OF PILE CAP ELEVATION. PROVIDE CONTINUOUS TIMBER BLOCKING CUT TO FIT RADII (OR GLUE-LAM FILLER) IN BETWEEN GLUE-LAM PILE CAP AND GLUE-LAM FASCIA TO GET EQUAL TOP OF FASCIA/RANGER ELEVATION (APPROX. 2") - SECURE WITH PL400 ADHESIVE OR APPROVED EQUAL AND SS SCREWS.

1	ISSUED FOR CONSTRUCTION	DCM	2-12-15
No.	Description	Approv.	Date

DRAWING REVISIONS

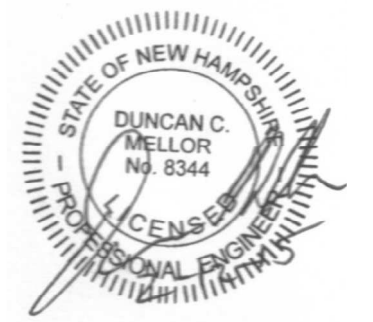

Date: 02/12/15
Scale: As Shown
Designer: DCM
Approved by: DCM
Project No:
File:

HARBORWALK PARK

DANIEL STREET AT
MEMORIAL BRIDGE



CITY OF PORTSMOUTH

DEPARTMENT OF PUBLIC WORKS
680 Peverly Hill Road

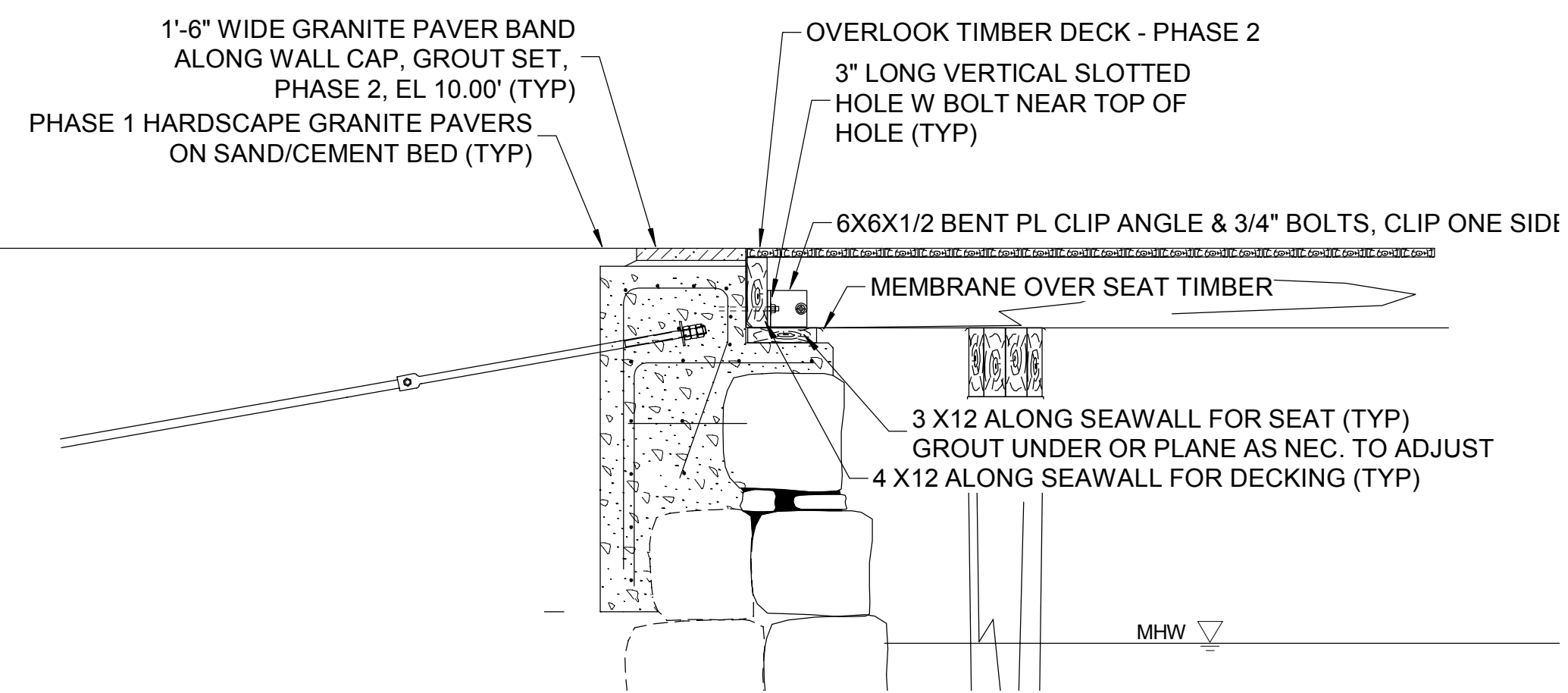

SEAWALL CAP DETAIL AT STRINGER (TYP)

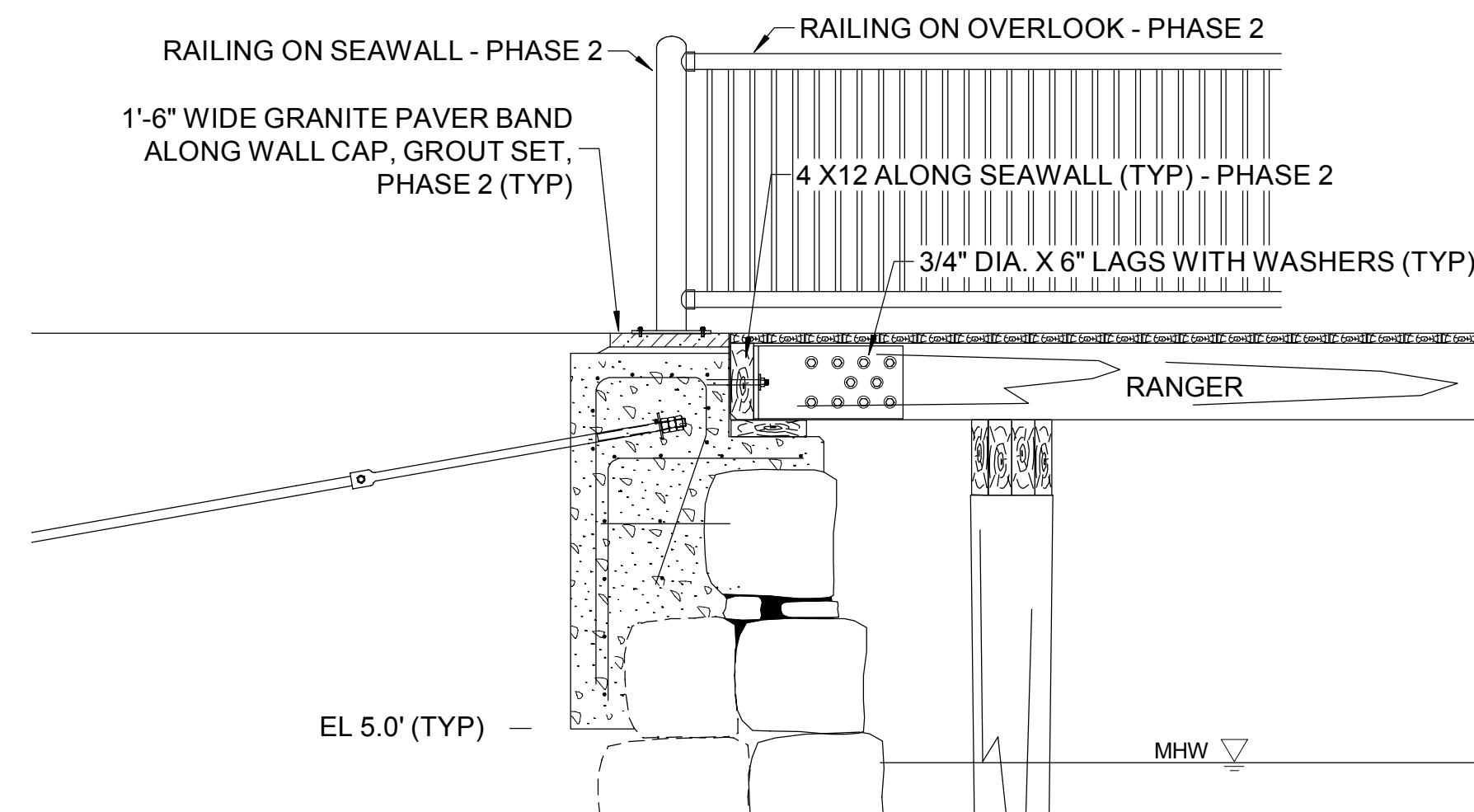

SEAWALL CAP DETAIL AT RANGER (TYP)

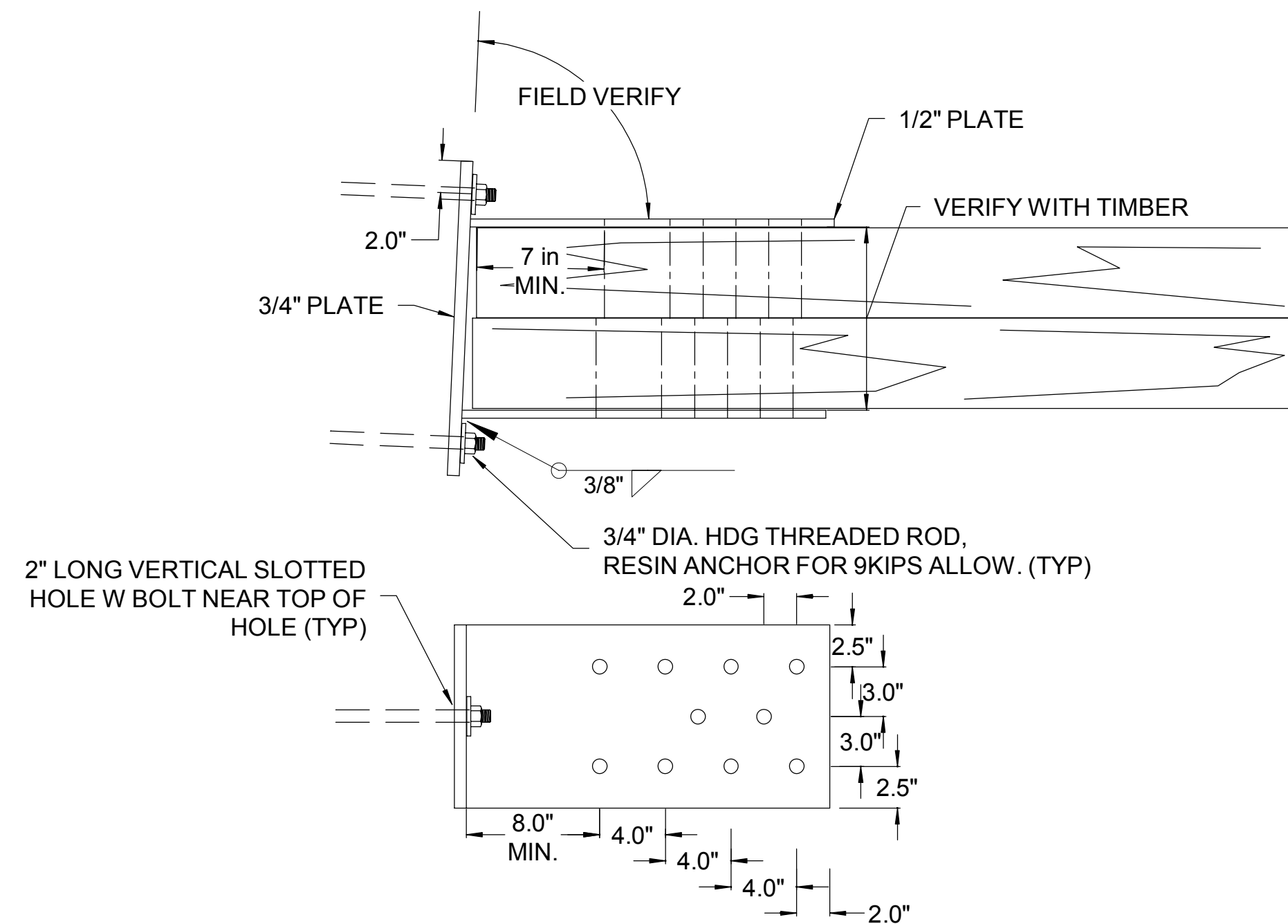

RANGER CONNECTION DETAIL (TYP)

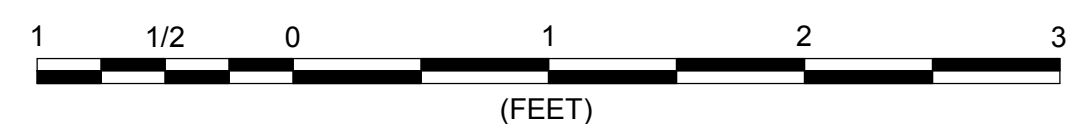

WATERFRONT ENGINEERS LLC

3 Linda Lane
Stratham, New Hampshire
(603) 772-3706
www.waterfrontengineers.com

1	ISSUED FOR CONSTRUCTION	DCM	2-12-15
No.	Description	Approv.	Date

DRAWING REVISIONS

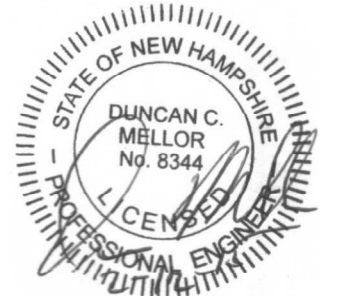

Date: 02/12/15
Scale: As Shown
Designer: DCM
Approved by: DCM
Project No:
File:

HARBORWALK PARK

DANIEL STREET AT
MEMORIAL BRIDGE



CITY OF PORTSMOUTH
DEPARTMENT OF PUBLIC WORKS
680 Peverly Hill Road

WATERFRONT ENGINEERS LLC

3 Linda Lane
Stratham, New Hampshire
(603) 772-3706
www.waterfrontengineers.com