

LEGEND:

EXISTING	PROPOSED	
---	---	PROPERTY LINE
---	---	RIGHT-OF-WAY
---	---	EDGE OF PAVEMENT
---	---	CURB
---	---	VGC
---	---	SIDEWALK
---	---	SYMBOL SIGN
---	---	RETAINING WALL
---	---	SHRUB
---	---	TREE
---	---	TEMPORARY BENCHMARK
---	---	1' CONTOUR
---	---	SPOT GRADE
---	---	TRANSFORMER
---	---	EV POWER STATION
---	---	PAY METER
---	---	DRAINAGE
---	---	WATER
---	---	GRAVITY SEWER
---	---	U/G ELECTRIC
---	---	U/G COMMUNICATIONS
---	---	OVERHEAD WIRES
---	---	GAS
---	---	FIRE HYDRANT
---	---	LIGHT POLE
---	---	UTILITY POLE w/ LIGHT
---	---	CATCHBASIN
---	---	MANHOLE
---	---	WATER SHUT OFF
---	---	WATER VALVE

- NOTES:**
- BINDER AND WEARING COURSE FOR PARKING LOT PAVEMENT SHALL BE PAID AS MACHINE METHOD.
 - HAND METHOD PAVEMENT PAY ITEM IS RESERVED FOR TRENCH PATCHES AND MISC. SMALL AREAS BEYOND THE MAIN PARKING LOT.
 - PARKING LOT PAY/METER SIGNS SHALL BE REMOVED, STORED IN A SAFE LOCATION AND RESET.
 - NEW SIGN POSTS SHALL BE SCH 40 ROUND GALVANIZED STEEL POSTS, PAINTED BLACK TO MATCH EXISTING.
 - CONTRACTOR SHALL CONTACT CITY OF PORTSMOUTH PARKING DEPARTMENT TO REMOVE EXISTING PAY METERS.
 - CITY PARKING DEPARTMENT RESPONSIBLE TO INSTALL NEW METERS ON CONTRACTOR PROVIDED PADS.
 - PAY ITEM 306.212 REHANDLE RECLAIM SHALL INCLUDE MOVING MATERIAL IN ORDER TO EXCAVATE SUB-GRADE, THEN PLACING THE MATERIAL BACK IN PLACE. REMOVAL AND REPLACEMENT CONSTITUTES A SINGLE "REHANDLING" OF THE MATERIAL.
 - ITEMS IDENTIFIED FOR REMOVAL (UNLESS OTHERWISE SPECIFIED) SHALL BECOME THE PROPERTY OF THE CONTRACTOR TO REMOVE AND DISPOSE OF OFF-SITE IN CONJUNCTION WITH ALL APPLICABLE CODES AND LAWS.

RECLAIM, GRADE AND RECONSTRUCT PAVEMENT (SEE C-402 FOR PROFILE)

GRAPHIC SCALE
1" = 30'

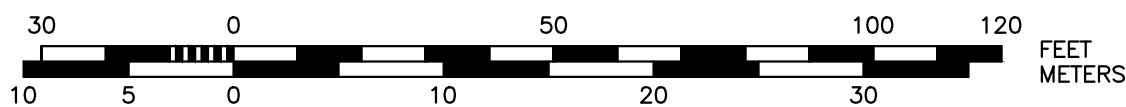

 DEPARTMENT OF
 PUBLIC WORKS
 CITY OF PORTSMOUTH, NH
 680 PEVERLY HILL ROAD
 603-427-1530

0	ISSUED FOR BID	MRB	02/08/22
NO.	REVISIONS	APP'D	DATE
PROJECT: BRIDGE STREET PARKING LOT			
TITLE: PARKING LAYOUT and DEMO PLAN			
DRAWING SCALE:	AS SHOWN	DATE:	JANUARY 2022
PROJECT NO.:	2022 AP	SHEET:	C-100
APPROVED BY:	DSD		

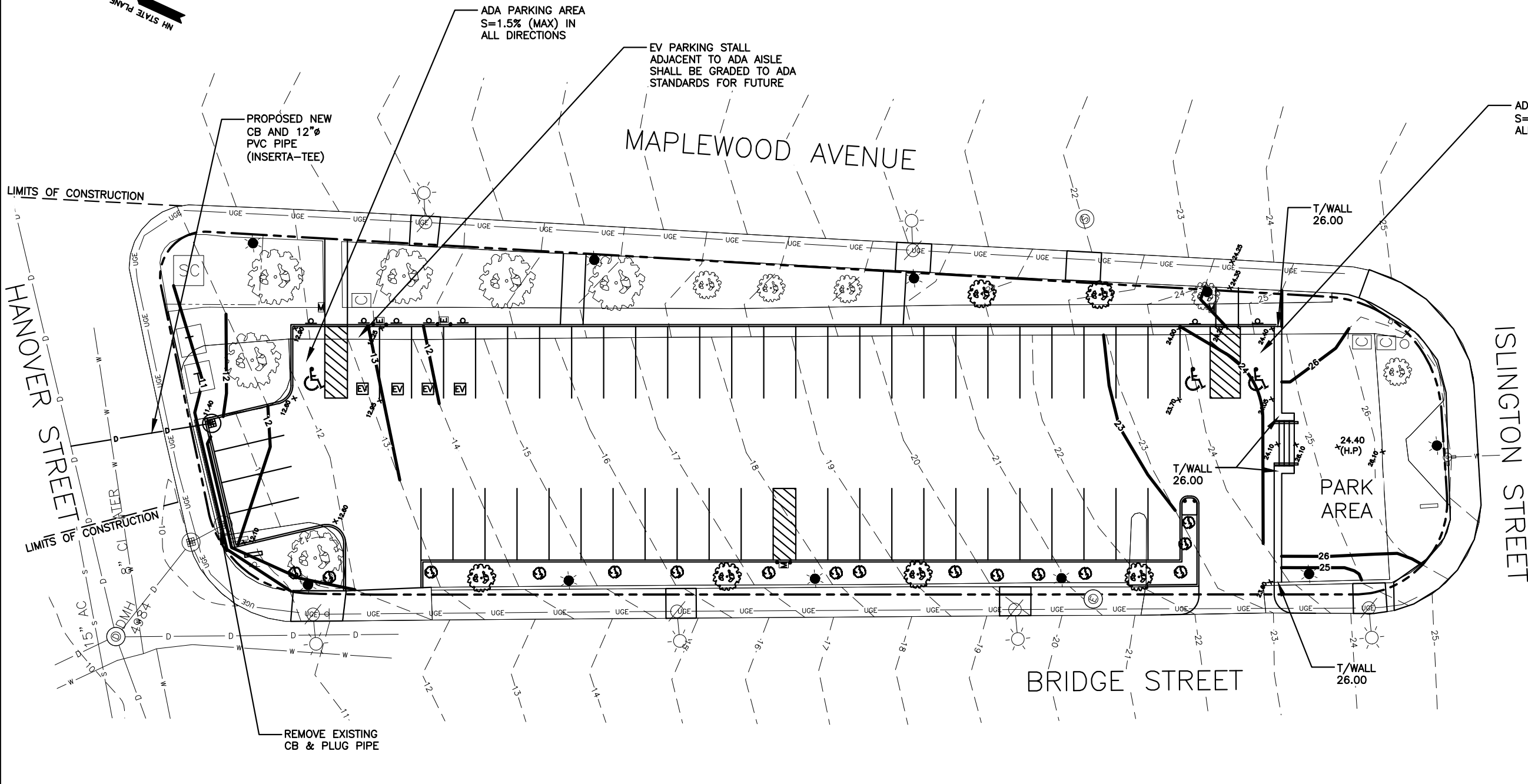
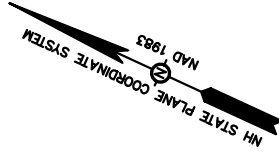

LEGEND:

EXISTING	PROPOSED	
---	---	PROPERTY LINE
---	---	RIGHT-OF-WAY
---	---	EDGE OF PAVEMENT
---	---	CURB
---	---	SIDEWALK
⊕	⊕ EV	SYMBOL SIGN
---	---	RETAINING WALL
⊗	⊗	SHRUB
⊙	⊙	TREE
⊕	⊕	TEMPORARY BENCHMARK
---	---	1' CONTOUR
---	---	SPOT GRADE
T	T	TRANSFORMER
⊕	⊕	EV POWER STATION
⊕	⊕	PAY METER
---	---	DRAINAGE
---	---	WATER
---	---	GRAVITY SEWER
---	---	U/G ELECTRIC
---	---	U/G COMMUNICATIONS
---	---	OVERHEAD WIRES
---	---	GAS
---	---	FIRE HYDRANT
---	---	LIGHT POLE
---	---	UTILITY POLE w/ LIGHT
---	---	CATCHBASIN
---	---	MANHOLE
---	---	WATER SHUT OFF
---	---	WATER VALVE

NOTES:
 1. UTILITIES AND GRADING SHOWN ARE BASED ON GIS DATA AND NOT GUARANTEED. CONTRACTOR TO VERIFY.
 2. CONTRACTOR SHALL CONTACT DIG-SAFE 72 HOURS PRIOR TO ALL EXCAVATION.

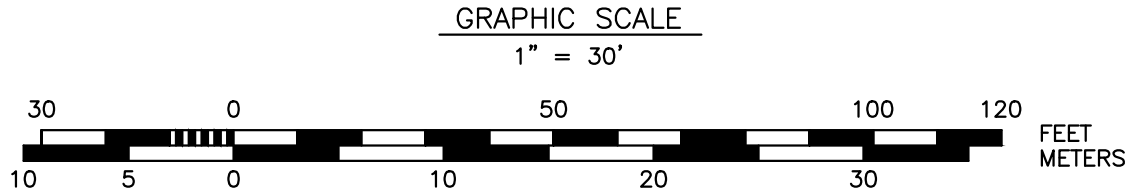

DEPARTMENT OF PUBLIC WORKS
CITY OF PORTSMOUTH, NH
 680 PEVERLY HILL ROAD
 603-427-1530

0	ISSUED FOR BID	MRB	02/08/22
NO.	REVISIONS	APP'D	DATE
PROJECT: BRIDGE STREET PARKING LOT			
TITLE: GRADING and DRAINAGE PLAN			
DRAWING SCALE:	AS SHOWN	DATE:	JANUARY 2022
PROJECT NO.:	2022 AP	SHEET:	C-200
APPROVED BY:	DSD		

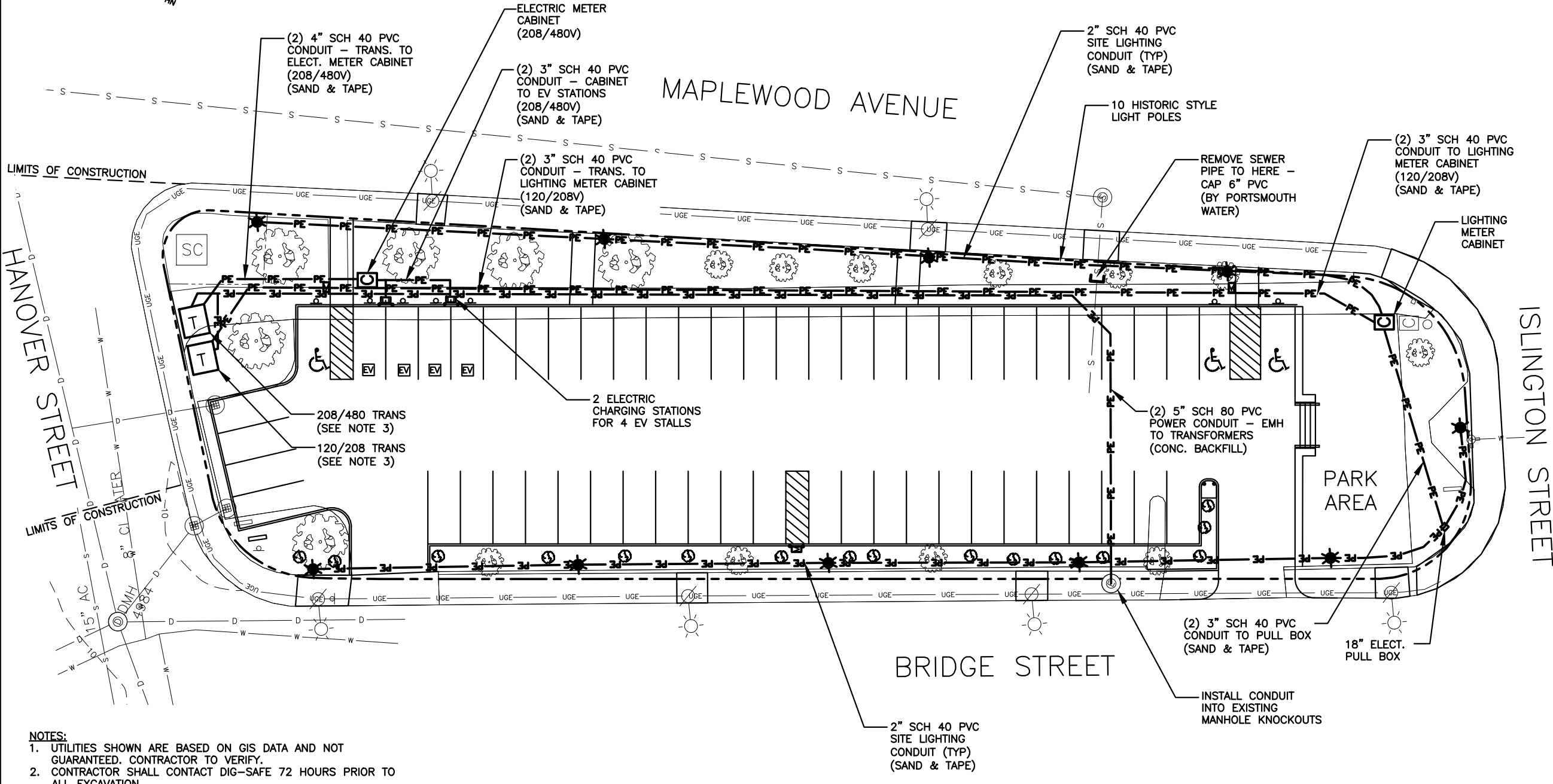
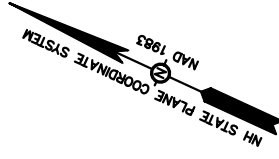

LEGEND:

EXISTING	PROPOSED	
---	---	PROPERTY LINE
---	---	RIGHT-OF-WAY
---	---	EDGE OF PAVEMENT
---	---	CURB
---	---	SIDEWALK
⊕	⊕	SYMBOL SIGN
---	---	RETAINING WALL
⊗	⊗	SHRUB
⊙	⊙	TREE
⊕	⊕	TEMPORARY BENCHMARK
---	---	1' CONTOUR
---	---	SPOT GRADE
T	T	TRANSFORMER
⊕	⊕	EV POWER STATION
⊕	⊕	PAY METER
---	---	DRAINAGE
---	---	WATER
---	---	GRAVITY SEWER
---	---	U/G ELECTRIC
---	---	U/G COMMUNICATIONS
---	---	OVERHEAD WIRES
---	---	GAS
---	---	FIRE HYDRANT
---	---	LIGHT POLE
---	---	UTILITY POLE w/ LIGHT
---	---	CATCHBASIN
---	---	MANHOLE
---	---	WATER SHUT OFF
---	---	WATER VALVE

- NOTES:**
1. UTILITIES SHOWN ARE BASED ON GIS DATA AND NOT GUARANTEED. CONTRACTOR TO VERIFY.
 2. CONTRACTOR SHALL CONTACT DIG-SAFE 72 HOURS PRIOR TO ALL EXCAVATION.
 3. EVERSOURCE IS RESPONSIBLE TO SET NEW TRANSFORMERS ON CONTRACTOR PROVIDED CONCRETE PADS.
 4. CONTRACTOR SHALL COORDINATE ALL UTILITY WORK WITH THE APPROPRIATE CONTACTS:
 ELECTRIC - EVERSOURCE
 GAS - UNITIL
 COMMUNICATIONS - COMCAST & CONSOLIDATED
 WATER, SEWER & DRAIN - CITY OF PORTSMOUTH - DPW

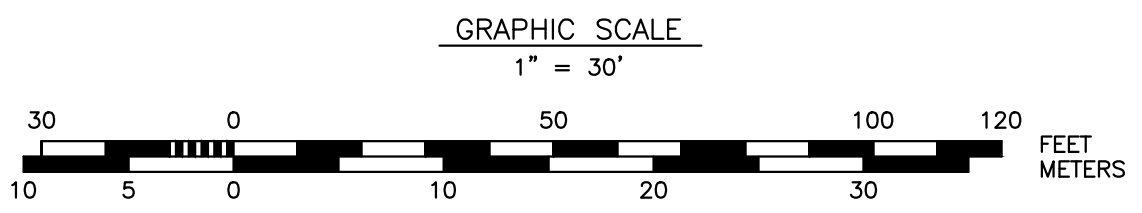

DEPARTMENT OF PUBLIC WORKS
CITY OF PORTSMOUTH, NH
 680 PEVERLY HILL ROAD
 603-427-1530

0	ISSUED FOR BID	MRB	02/08/22
NO.	REVISIONS	APP'D	DATE
PROJECT: BRIDGE STREET PARKING LOT			
TITLE: UTILITIES PLAN			
DRAWING SCALE:	AS SHOWN	DATE:	JANUARY 2022
PROJECT NO.:	2022 AP	SHEET:	C-300
APPROVED BY:	DSD		

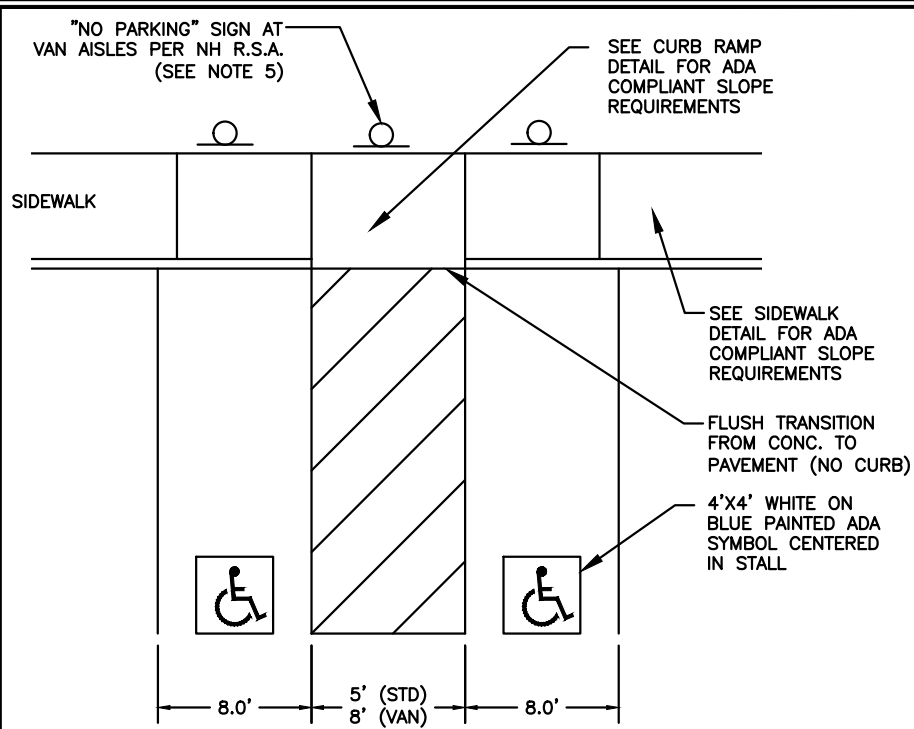

ADA PARKING DETAIL
SCALE: N.T.S

- NOTES:**
1. AISLE STRIPING SHALL BE AT A 45 ANGLE AT 36" O.C.
 2. ADA SIGNS SHALL BE POLE MOUNTED TO A HEIGHT OF 60" (MIN) FROM BOTTOM OF SIGN TO PARKING SURFACE.
 3. ADA PARKING STALL AND AISLES SHALL BE GRADED TO 1.5% SLOPES IN ALL DIRECTIONS.
 4. SIGNS SHALL BE PLACED EITHER BEHIND SIDEWALK OR BEHIND CURB (WHERE NO SIDEWALK).
 5. "NO PARKING" SIGN AT HEAD OF AISLE MAY BE OMITTED IF IT BLOCKS THE ACCESSIBLE ROUTE.
 6. COMPLY WITH ALL APPLICABLE ADA CODES.



- NOTES:**
1. TEXT SHALL BE WHITE ON A GREEN 4'x4' SQUARE CENTERED IN STALL.

EV PARKING DETAIL
SCALE: N.T.S

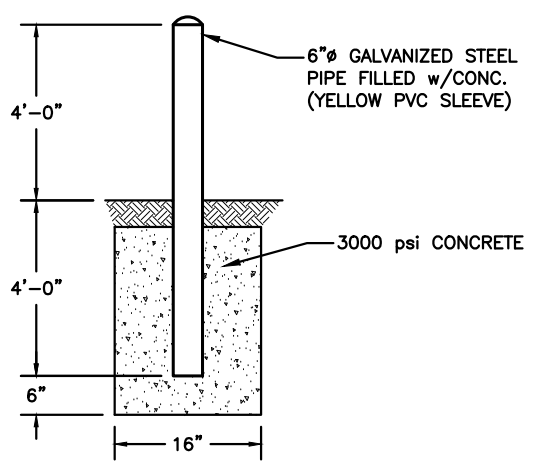

- NOTES:**
1. SEE SITE PLAN FOR LOCATIONS.
 2. DISTURBED AREA AROUND BOLLARD SHALL BE RESTORED TO MATCH EXISTING.

BOLLARD
SCALE: N.T.S

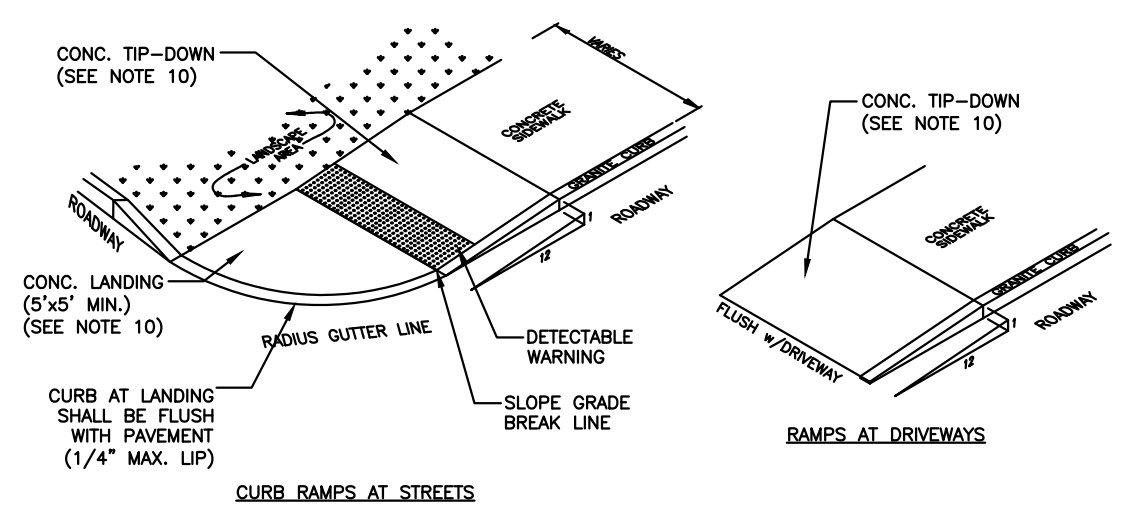

CURB RAMP AT STREETS

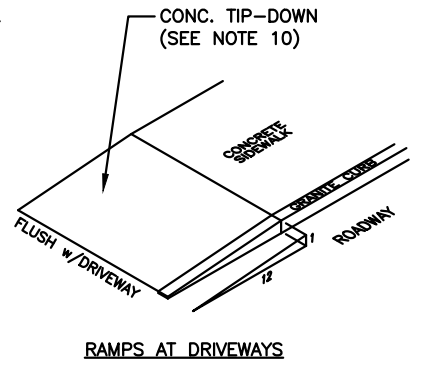

RAMP AT DRIVEWAYS

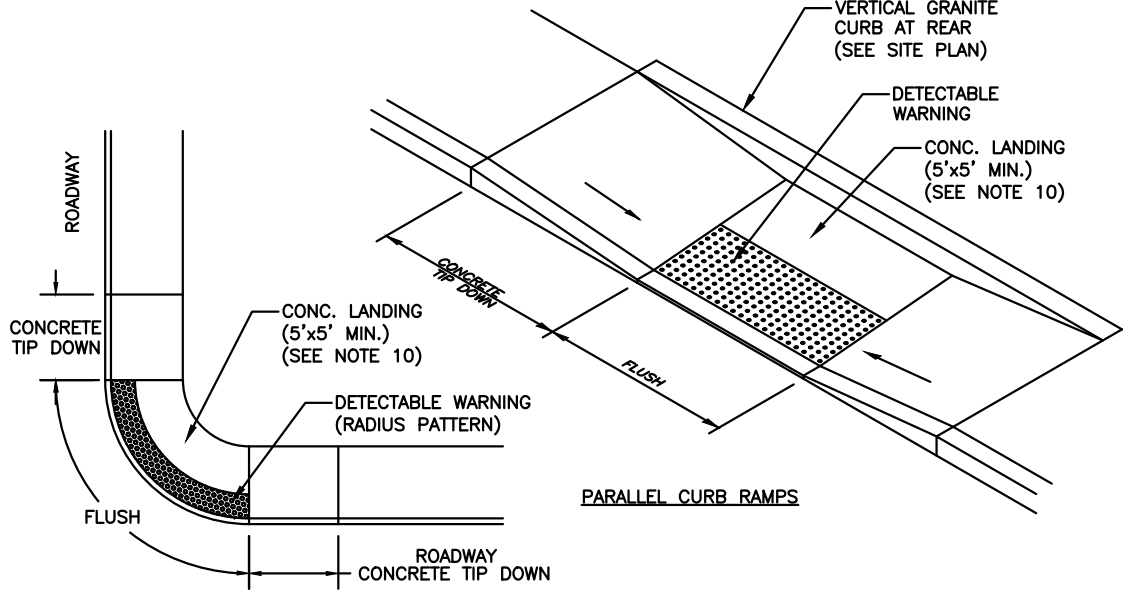

PARALLEL CURB RAMP

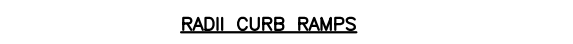

RADI CURB RAMP

- NOTES:**
1. ALL CURB RAMP AND ACCESSIBLE ROUTES (SIDEWALKS) SHALL COMPLY WITH ADA (AMERICANS WITH DISABILITIES ACT).
 2. TIP DOWNS SHALL HAVE A RUNNING SLOPE OF 7.5% (8.3% MAX.) AND CROSS SLOPE OF 1.5% (2.0% MAX.).
 3. THERE SHALL BE NO CHANGE IN ELEVATION (LIP) OR GAPS IN THE SIDEWALK RAMP GREATER THAN 1/4".
 4. LANDINGS AND AREAS OF CHANGE IN DIRECTION SHALL HAVE A SLOPE OF 1.5% (2.0% MAX.) IN ALL DIRECTIONS.
 5. DETECTABLE WARNING TILES ARE REQUIRED AT ALL ROADWAY CROSSINGS AND AT SIGNALIZED DRIVEWAYS ONLY.
 6. DETECTABLE WARNINGS SHALL BE INSTALLED SO THAT PATTERN IS IN LINE WITH DIRECTION OF TRAVEL TO THE EXTENT POSSIBLE.
 7. DETECTABLE WARNING TILES SHALL BE PLACED SO THAT THE EDGE CLOSEST TO THE CURB IS BETWEEN 6"-8" FROM CURB LINE.
 8. DETECTABLE WARNING TILE SHALL SPAN THE FULL WIDTH OF THE RAMP AND A MINIMUM OF 24" DEEP.
 9. DETECTABLE WARNING TILE SHALL BE CAST IRON, NEENAH FOUNDRY OR APPROVED EQUAL. RADIUS ADA CURB RAMP SHALL HAVE DETECTABLE WARNING TILES IN A RADIUS PATTERN USING TUFTILE OR APPROVED EQUAL.
 10. CONCRETE AT LANDINGS OR TIP-DOWNS THAT CONTAIN DETECTABLE WARNING TILES AND/OR AREAS THAT ARE SUSCEPTIBLE TO VEHICLES TRAVELING OVER, SHALL BE 6" THICK w/FIBER REINFORCEMENT AND A MEDIUM BROOM FINISH. ALL OTHER RAMP SHALL BE 4" THICK AND COMPLY WITH CONCRETE SIDEWALK SPECIFICATIONS.
 11. BASE MATERIAL FOR CONCRETE SECTIONS SHALL BE 8" THK CRUSHED GRAVEL BASE (NHDOT 304.3).

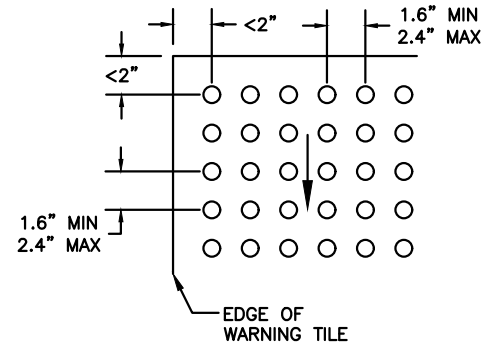

DETECTABLE WARNING TILE

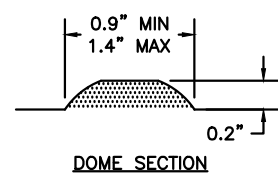

DOM SECTION

CURB RAMP DETAILS
SCALE: N.T.S

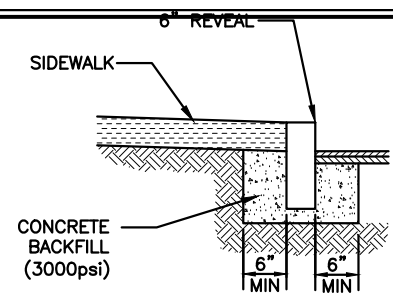

RADIUS	MAX. LENGTH
<20'	USE CURVED CURB
21'-25'	3'
26'-30'	4'
31'-35'	5'
36'-40'	6'
41'-50'	7'
51'-56'	8'
56'-60'	9'
OVER 60'	10'

- NOTES:**
1. CURB TO BE SET TO LINE AND GRADE SPECIFIED.
 2. ALL RADII 20 FEET AND SMALLER SHALL USE CURVED SECTIONS.
 3. CURB AT FLUSH SECTION OF SIDEWALK SHALL BE SET TO 1.5% (2.0% MAX.) SLOPE. CURB AT RAMP SHALL BE SET TO 7.5% (8.3% MAX.). IT IS THE CURB CONTRACTORS RESPONSIBILITY TO VERIFY SLOPES WITH A SMART LEVEL.
 4. VERTICAL GRANITE JOINTS SHALL BE MORTARED.
 5. SEE CHART FOR MAX / MIN STONE LENGTHS.
 6. RESET EXISTING CURB. ANY MISSING OR DAMAGED CURB SHALL BE REPLACED WITH MATCHING CURB SIZE.
 7. NO CURB LESS THAN 3' IN LENGTH WILL BE ALLOWED.
 8. CURB MATERIAL SHALL BE FROM THE SAME LOT OF GRANITE. VARIANCES IN COLOR AND TYPE WILL NOT BE ACCEPTED.

VERTICAL GRANITE CURB
SCALE: N.T.S

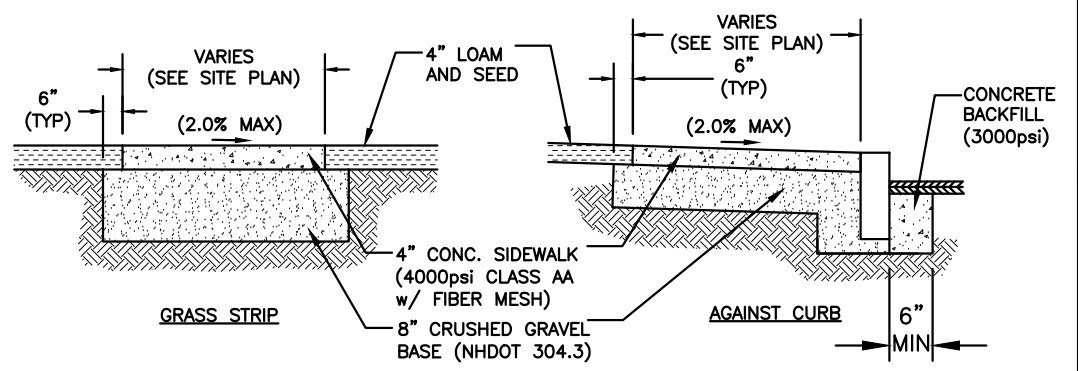

- NOTES:**
1. MEDIUM BROOM FINISH.
 2. JOINTS SHALL BE HAND TOOLED w/ 1/8" RADII.
 3. EXPANSION JOINT FIBER FILLER SHALL BE TRIMMED TO 1/4" BELOW SIDEWALK SURFACE FOR SEALANT.
 4. THERE SHALL BE NO CHANGE IN ELEVATION (LIP) OR GAPS IN THE SIDEWALK GREATER THAN 1/4".
 5. SIDEWALK CONCRETE SHALL BE TREATED WITH SILOXANE SEALER.
 6. SIDEWALKS SHALL HAVE A CROSS SLOPE OF 1.5% TO ALLOW FOR CONSTRUCTION TOLERANCES (1.0% MIN. AND 2.0% MAX). ADA CODE ALLOWS FOR CROSS SLOPE OF 2.0% MAX.
 7. SIDEWALKS SHALL HAVE A RUNNING SLOPE OF 4.5% TO ALLOW FOR CONSTRUCTION TOLERANCES (5.0% MAX). ADA CODE ALLOWS FOR RUNNING SLOPE OF 5.0% MAX.
 8. CONTRACTOR SHALL HAVE KNOWLEDGE OF ADA REQUIREMENTS, SLOPES EXCEEDING ADA MAXIMUMS WILL BE REJECTED AND REPLACED AT NO ADDITIONAL COST. CONTRACTOR SHALL NOTIFY THE ENGINEER PRIOR TO FINAL GRADING IN THE EVENT ADA COMPLIANT SLOPES CANNOT BE ACHIEVED.
 9. COMPLY WITH ALL APPLICABLE ADA CODES FOR ACCESSIBLE ROUTE.

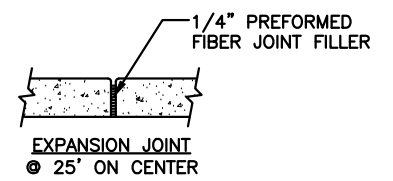

EXPANSION JOINT
@ 25' ON CENTER

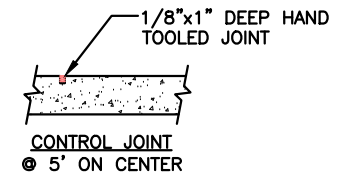

CONTROL JOINT
@ 5' ON CENTER

CONCRETE SIDEWALK
SCALE: N.T.S

DEPARTMENT OF PUBLIC WORKS
CITY OF PORTSMOUTH, NH
 680 PEVERLY HILL ROAD
 603-427-1530

0	ISSUED FOR BID	MRB	02/08/22
NO.	REVISIONS	APP'D	DATE
PROJECT: BRIDGE STREET PARKING LOT			
TITLE: DETAILS SHEET			
DRAWING SCALE:	AS SHOWN	DATE:	JANUARY 2022
PROJECT NO.:	2022 AP	SHEET:	C-401
APPROVED BY:	DSD		



EV SIGN 12x18 (1.5sf)
 R7-8 12x18 (1.5sf)
 R5-1 12x18 (1.5sf)
 VAN ACCESSIBLE R7-8P 12x6 (1.5sf)

- NOTES:
 1. CONTACT CITY OF PORTSMOUTH PARKING DEPARTMENT FOR PAY METER SIGNAGE REQUIREMENTS.
 2. SIGN POSTS SHALL BE ROUND BLOCK POLES THAT MATCH EXISTING.

SIGNS AND POST
 SCALE: N.T.S

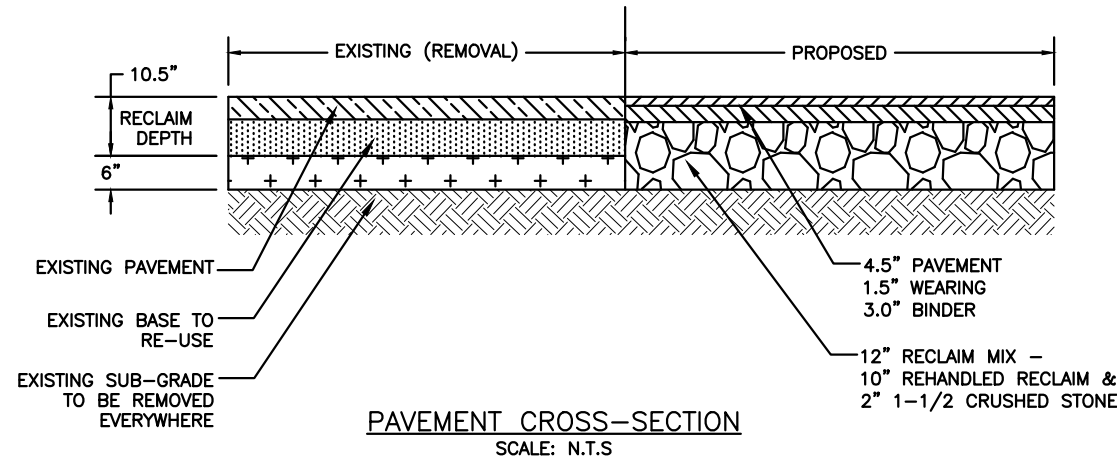

- NOTES:
 1. RECLAIMED STABILIZED BASE SHALL COMPLY WITH NHDOT ITEM 306.
 2. RECLAIM MATERIAL TO BE TESTED TO DETERMINE IF ADDITIONAL 1.5" STONE WILL BE ADDED. IN THE EVENT ADDITIONAL CRUSHED STONE IS REQUIRED, CONTRACTOR SHALL SPREAD STONE TO THE REQUIRED THICKNESS AND RECLAIM MATERIAL A SECOND TIME TO MIX ADDED STONE. REHANDLING RECLAIM SHALL INCLUDE REMOVAL OF RECLAIMED MATERIAL AND PLACING BACK AFTER EXCESS SUB-GRADE MATERIAL HAS BEEN REMOVED. THE ACT OF REMOVING AND REPLACING SHALL CONSTITUTE "REHANDLING" ONCE. QUANTITY PAID SHALL BE MATERIAL PLACED AND COMPACTED.

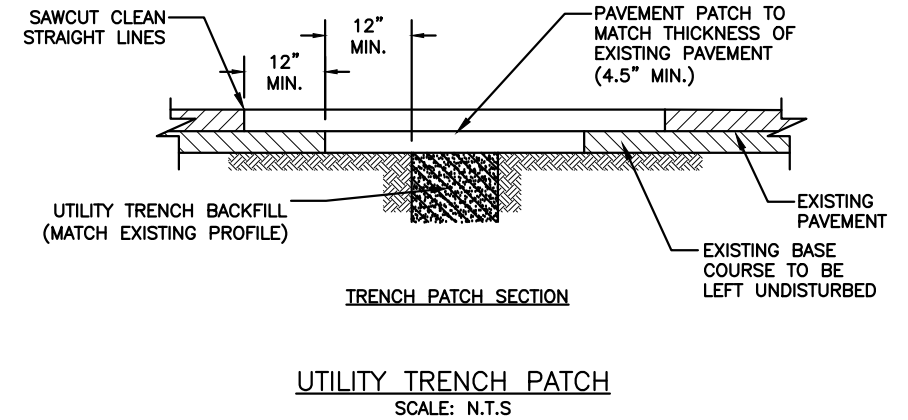

UTILITY TRENCH PATCH
 SCALE: N.T.S



- NOTES:
 1. CABINET SHALL BE MILLBANK ELECTRICAL CABINET CP3B51215A22SSBKSP1 OR AS APPROVED
 2. CABINET SHALL BE BLACK IN COLOR COORDINATE WITH CITY OF PORTSMOUTH FOR APPROVAL OF CABINET.
 3. PAY ITEM INCLUDES ALL ITEMS WITHIN THE CONTROL BOX TO RENDER THE POWER CONTROL SYSTEM OPERATIONAL.
 4. SIMILAR CABINETS LOCATED ON ISLINGTON STREET FOR REFERENCE.
 5. TWO METER CABINETS REQUIRED:
 6.1. 120/208 - 200 AMP
 6.2. 208/480 - 800 AMP

ELECTRIC CONTROL BOX & BASE
 SCALE: N.T.S

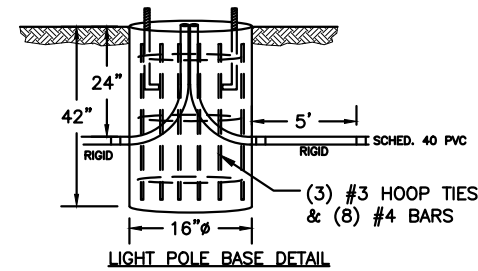

- NOTES:
 1. CONCRETE FOR BASE SHALL BE 4,000psi MINIMUM AFTER 28 DAYS.
 2. RIGID PIPE SHALL BE GALVANIZED.
 3. BOLT AND ANCHOR REQUIREMENTS AS SPECIFIED BY POLE MANUFACTURER.
 4. LIGHT POLE BASE SHALL BE SET FLUSH WITH FINISHED GRADE.

STREET LIGHT DETAILS
 SCALE: N.T.S

LANTERN: NEWSTAMP LIGHTING #RS-TUR-177 "PORTSMOUTH" w/MEDIUM BASE EXTERIOR 3000K LED LAMPS

POLE: SPRING CITY MODEL "HANCOCK" 10'-2" DUCTILE IRON w/INTERIOR ANCHORS w/o LADDER REST

MOUNT POLE 1/2" ABOVE GRADE

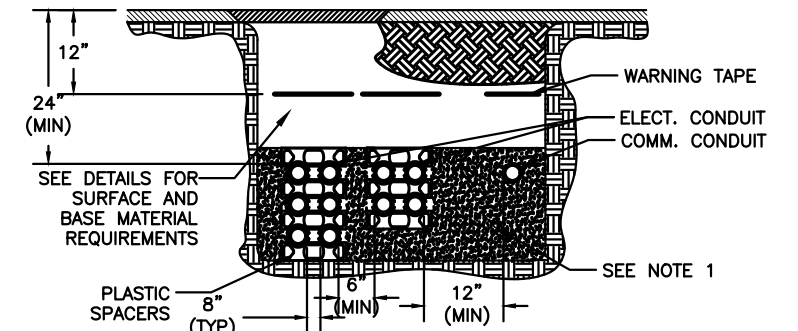
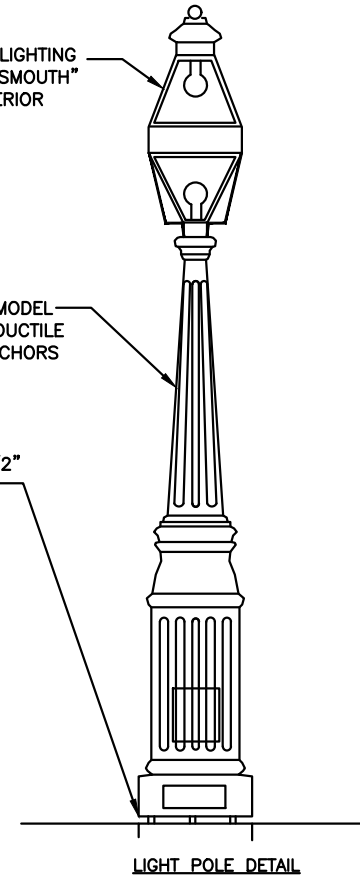

- NOTES:
 1. BEDDING AND COVER SHALL BE:
 1.1. SAND (6" MIN. AROUND) FOR LOW VOLTAGE
 1.2. CONCRETE ENCASED FOR PRIMARY (SAND & TAPE ABOVE)
 2. VERIFY QTY, MATERIAL & SIZE OF CONDUITS w/ UTILITY CO.
 3. DIMENSIONS SHOWN ARE CITY MINIMUM REQUIREMENTS, ACTUAL DIMENSIONAL REQUIREMENTS MAY BE GREATER BASED ON UTILITY CO. STANDARDS.
 4. NO CONDUIT RUN SHALL EXCEED 360° IN BENDS.
 5. ALL CONDUIT SHALL BE U.L. LISTED SCH 40 EXCEPT UNDER ROADS, WHERE SCH 80 IS REQUIRED.
 6. A 200# PULL ROPE SHALL BE BLOWN IN TO EACH CONDUIT AFTER ASSEMBLY.
 7. CONTRACTOR TO COORDINATE INSPECTIONS WITH UTILITY COMPANY PRIOR TO BACKFILL.
 8. ALL CONDUIT SHALL CONFORM TO CURRENT EDITION OF THE NATIONAL ELECTRIC SAFETY CODE, AND ALL STATE AND LOCAL CODES.
 9. ALL 90° SWEEPS SHALL BE MADE USING RIGID GALVANIZED STEEL SWEEPS WITH A 36" TO 48" RADIUS.

ELECTRICAL CONDUIT TRENCH
 SCALE: N.T.S

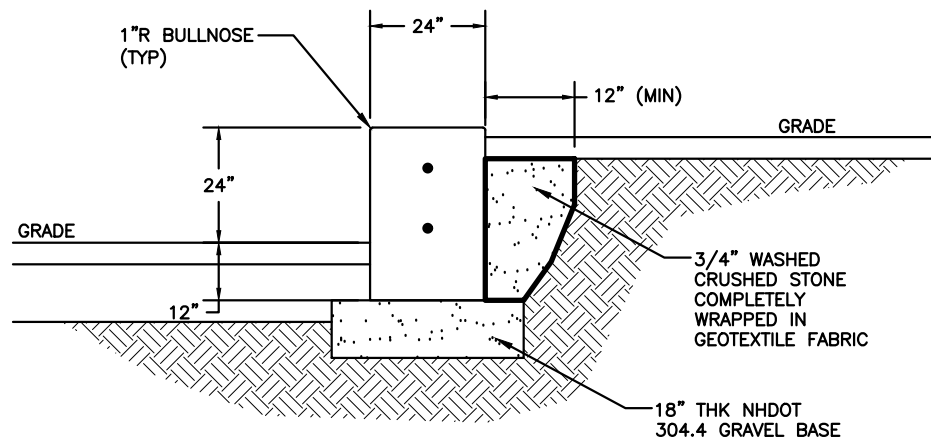

- NOTES:
 1. GRANITE BLOCKS SHALL HAVE A THERMAL FINISH AND PINNED TOGETHER WITH (2) 6"L x 1/2"Ø STAINLESS STEEL DOWELS.
 2. GRAVEL BASE SHALL BE NHDOT 304.4 COMPACTED TO 95% PROCTOR.
 3. GEOTEXTILE FABRIC SHALL BE MIRAFI 140N OR APPROVED EQUAL.

GRANITE BLOCK WALL
 SCALE: N.T.S

- NOTES:
 1. GRANITE STEPS SHALL MANUFACTURED BY SWENSON GRANITE WORKS, OR APPROVED EQUAL.
 2. STEPS SHALL BE INSTALLED FLUSH TO ADJACENT SIDEWALKS OR PAVEMENT.
 3. STEPS SHALL BE PITCHED 1.0% TOWARDS THE FRONT OF EACH STEP FOR DRAINAGE. CROSS SLOPE OF STEPS SHALL BE FLAT (1.0% MAX) OR MATCH SIDEWALK CROSS SLOPE. CONTRACTOR IS RESPONSIBILITY TO VERIFY SLOPES WITH A SMART LEVEL.
 4. NEW GRANITE SHALL BE FROM THE SAME LOT OF GRANITE. VARIANCES IN COLOR AND TYPE WILL NOT BE ACCEPTED.
 5. SET SAND/CEMENT MIX: 3 PARTS SAND w/ 1 PART PORTLAND CEMENT
 6. STEPS SHALL COMPLY w/ ADA CODE SECTION 504.
 7. HANDRAILS SHALL BE ROUND GALVANIZED STEEL. FINISH SHALL BE PRIMED AND BLACK POWDER COATED. DRILL AND EPOXY HANDRAIL LEGS INTO GRANITE STEPS.
 8. HANDRAILS SHALL COMPLY w/ ADA CODE SECTION 505.
 9. STEPS SHALL BE INSET INTO GRANITE BLOCK WALL A DISTANCE TO ENSURE HANDRAILS DO NOT EXTEND PAST FACE OF WALL.

GRANITE STEPS & HANDRAILS
 SCALE: N.T.S

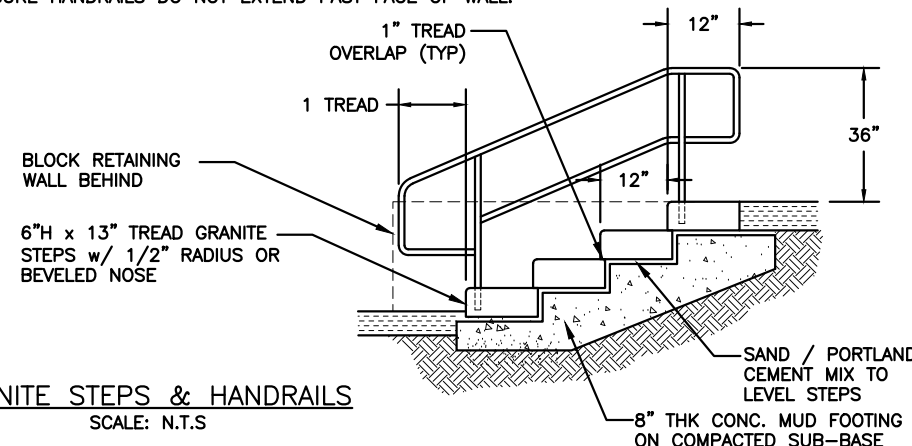

DEPARTMENT OF PUBLIC WORKS
 CITY OF PORTSMOUTH, NH
 680 PEVERLY HILL ROAD
 603-427-1530

0	ISSUED FOR BID	MRB	02/08/22
NO.	REVISIONS	APP'D	DATE
PROJECT: BRIDGE STREET PARKING LOT			
TITLE: DETAILS SHEET			
DRAWING SCALE:	AS SHOWN	DATE:	JANUARY 2022
PROJECT NO.:	2022 AP	SHEET:	C-402
APPROVED BY:	DSD		

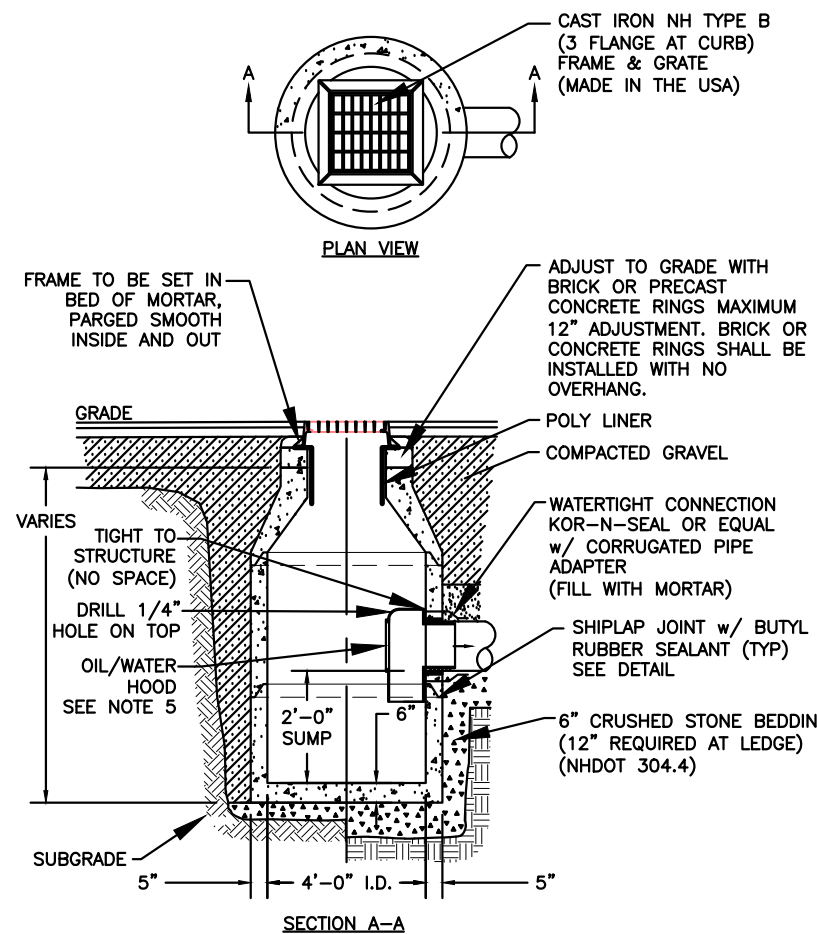

CATCH BASIN
SCALE: N.T.S

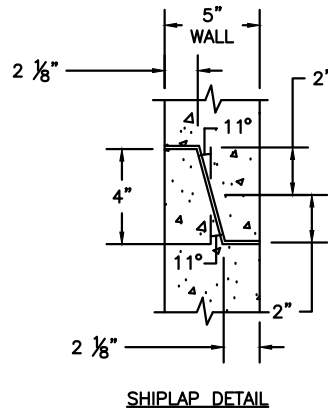

- NOTES:**
1. CONCRETE SHALL BE 4,000 P.S.I. AFTER 28 DAYS.
 2. CIRCUMFERENTIAL REINFORCEMENT SHALL BE 0.12 SQ. IN. PER LINEAR FT. IN ALL SECTIONS & SHALL BE PLACED IN THE CENTER THIRD OF WALL.
 3. THE TONGUE OR THE GROOVE OF THE JOINT SHALL CONTAIN ONE LINE OF CIRCUMFERENTIAL REINFORCEMENT EQUAL TO 0.12 SQ. IN. PER LINEAR FT.
 4. EACH CASTING TO HAVE LIFTING HOLES CAST IN.
 5. ALL CATCHBASINS OUTLETS SHALL HAVE 'ELIMINATOR' OIL AND FLOATING DEBRIS TRAP BY KLEANSTREAM (NO EQUAL). FOR EXIT ONLY CBs, NOT FOR PASS THROUGH CBs.
 6. CONTRACTOR SHALL SUBMIT SHOP DRAWING FOR APPROVAL PRIOR TO CASTING.

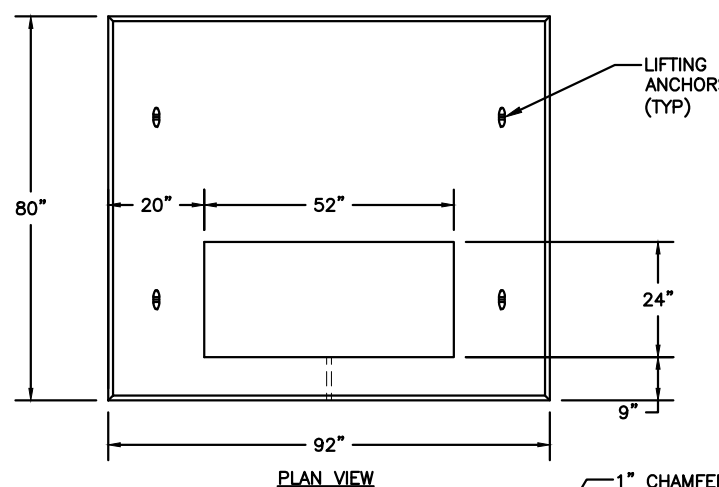

- NOTES:**
1. DIMENSIONS SHOWN REPRESENT TYPICAL REQUIREMENTS, CONTRACTOR SHALL COORDINATE WITH EVERSOURCE PRIOR TO CONSTRUCTION.
 2. CONCRETE MINIMUM STRENGTH SHALL BE 4000psi @ 28 DAYS.
 3. VERIFY GROUNDING GRID REQUIREMENTS WITH EVERSOURCE.
 4. REFER TO EVERSOURCE "REQUIREMENTS FOR ELECTRIC SERVICE CONNECTIONS" 2021 EDITION FOR REINFORCING STEEL REQUIREMENTS.
 5. CONTRACTOR SHALL SUBMIT SHOP DRAWINGS FOR APPROVAL PRIOR TO CASTING.

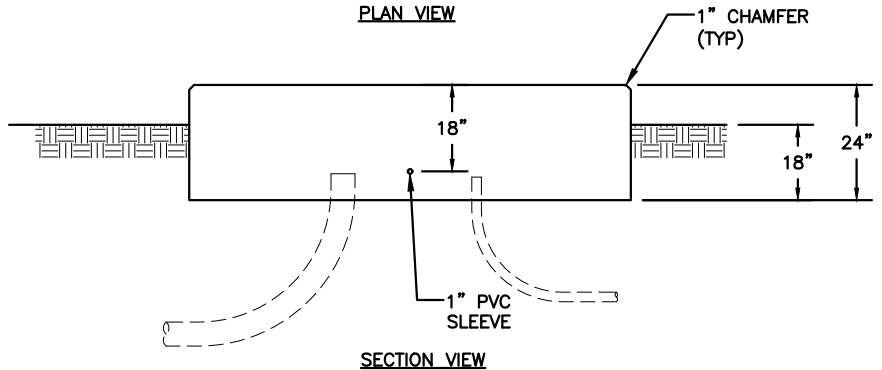

TRANSFORMER BASE
SCALE: N.T.S

Pay Item	Description	Units	Qty
201.1	Clearing & Grubbing Landscaped Areas (incl. Tree Protection)	LS	1
202.21	Removal of Existing Sidewalks	SY	350
202.3	Fill and Abandon Pipe or Structure	LF	20
202.4	Removal of Existing Pipe (as Directed by Engineer)	LF	20
202.5	Removal of CB, Drop Inlets, and Manholes	EA	1
203.1	Common Excavation (Sidewalks & Conc. Pads)	CY	50
203.1	Common Excavation (Pavement Sub-Grade - 6")	CY	300
214	Fine Grading (Pavement Base)	SY	2500
214	Fine Grading (Sidewalks)	SY	85
304.3	Crushed Gravel in Place (Pavement)	CY	20
304.3	Crushed Gravel in Place (Sidewalks)	CY	20
306.112a	12" Reclaimed Stabilized Base	SY	2700
306.112b	12" Reclaimed Stabilized Base (Blend in Stone)	SY	2000
306.212	Rehandle Reclaimed Based Material	CY	800
306.36	1.5-2.0" Crushed Stone (Mixed w/ Reclaimer)	TN	200
403.11A	Machine Method, Binder (3")	TN	400
403.11B	Machine Method, Wearing (1.5")	TN	200
403.12	Hand Method	TN	20
520	Class B Curb Backfill	CY	30
603.81212	12" Dia. PVC Drain Pipe	LF	35
603.8112	12" Dia. PVC Inserta Tee (Incl. Core)	EA	1
604.0007	Poly Liner for CB	EA	1
604.0008	Eliminator Oil/Water Separator	EA	1
604.12	New Catchbasin w/ Frame & Grate	EA	1
604.5	Adjust Existing Structures (Sewer, Drain, Elec, Tele)	EA	5
608.24A	4" Concrete Sidewalk & Pads	SF	800
608.24B	Concrete Pads (Parking Meter & EV Charge Station)	EA	5
608.6A	New Granite Steps	LF	48
608.6B	Reset Granite Seats on new Conc. Footing (if necessary)	EA	2
608.6C	ADA Handrails	EA	2
609.16	New 6" Straight Vertical Granite Curb	LF	230
609.26	New 6" Curved Vertical Granite Curb	LF	20
609.56	Reset Existing Vertical Granite Curb	LF	500
572.5	Granite Block Retaining Wall	LF	70
614	Install Transformer Pads (Pre-Cast)	EA	2
614	Install Site Lighting Cabinet, Complete (120/240)(Incl. Conc. Pad)	EA	1
614	Install Site Lighting Cabinet, Complete (208/480)(Incl. Conc. Pad)	EA	1
614.512	18" Conc. Electric Pull Box	EA	1
614.7214	2" Sch 40 PVC Conduit (Lighting)	LF	630
614.7314	3" Sch 40 PVC Conduit	LF	800
614.7414	4" Sch 40 PVC Conduit (Power)	LF	100
614.7518	5" Sch 80 PVC Conduit in Concrete (Primary Power)	LF	650
615	Bollard (Conc. Filled and Painted Yellow)	EA	8
615.0071A	New Steel Sign Posts	EA	10
615.0071B	Relocate Existing Sign Post	EA	5
615.02	New Parking Sign	SF	25
615.024A	Relocate Sign to New Post	EA	4
615.024B	Relocate Wayfinding or Lot Designation Sign (incl. new footings)	EA	2
625	Remove & Dispose Existing Light Pole & Base	EA	6
625.1	Light Pole Base	EA	10
625.1	Street Light Pole	EA	10
632.0104	4" Paint Striping (Chlorinated Rubber Paint)	LF	1200
632.02A	Painted ADA Symbol (incl. Blue Background)(4'x4')	EA	3
632.02B	Painted EV Symbol (4'x4')	EA	4
641	Loam for Planting Beds (18" Deep)	CY	125
1010.2	Asphalt Cement Adjustment	Allow	1000

PAY ITEM SCHEDULE
SCALE: N.T.S

DEPARTMENT OF PUBLIC WORKS
CITY OF PORTSMOUTH, NH
 680 PEVERLY HILL ROAD
 603-427-1530

0	ISSUED FOR BID	MRB	02/08/22
NO.	REVISIONS	APP'D	DATE
PROJECT: BRIDGE STREET PARKING LOT			
TITLE: DETAILS SHEET			
DRAWING SCALE:	AS SHOWN	DATE:	JANUARY 2022
PROJECT NO.:	2022 AP	SHEET:	C-403
APPROVED BY:	DSD		

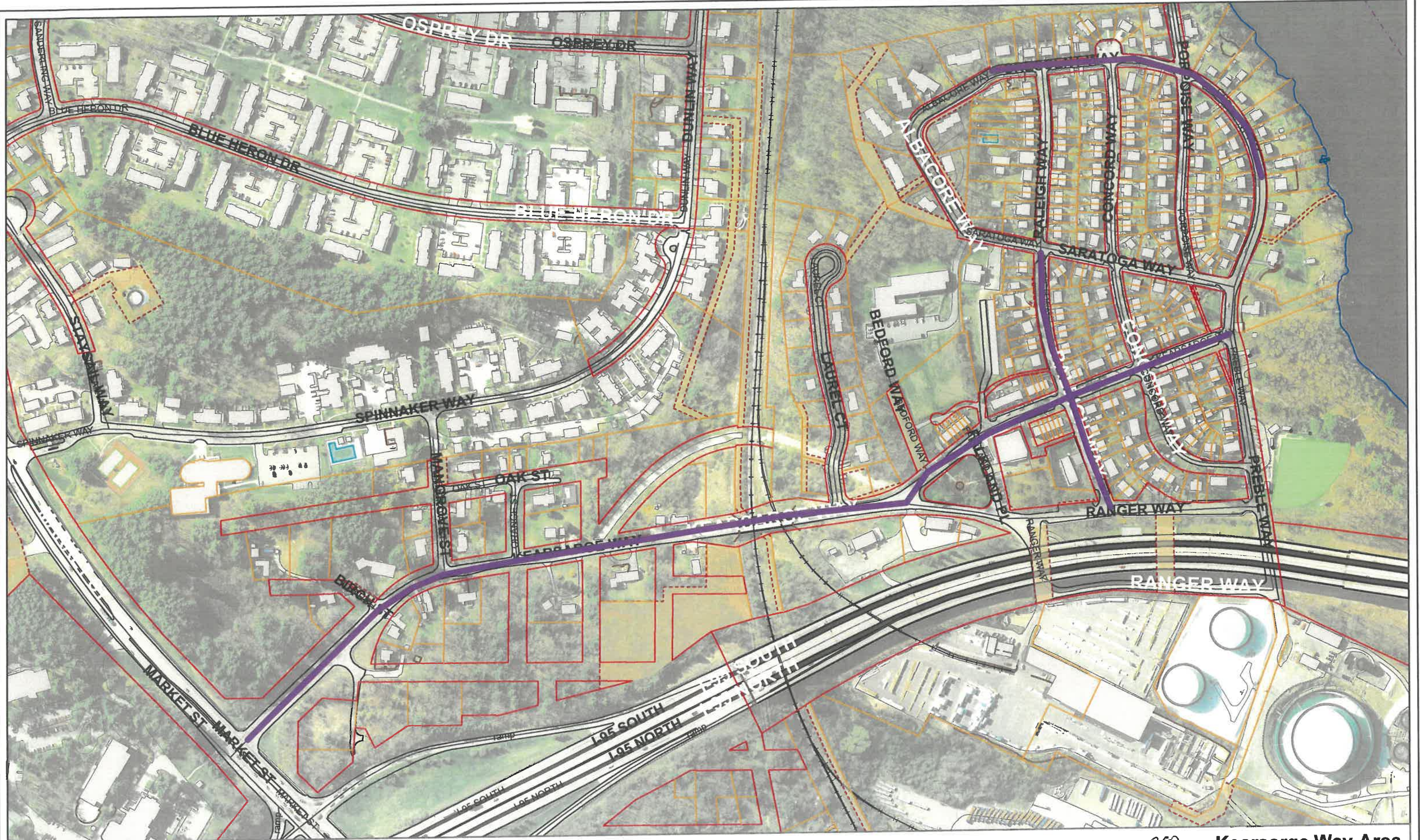

Mill and Fill roads
 patch roads as necessary

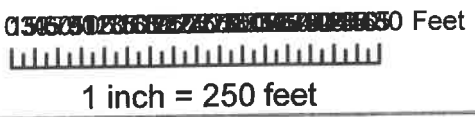

780 **Kearsarge Way Area**

Map prepared by Portsmouth Department of Public Works

Printed: 2/9/2022